



1974

# CHEVROLET

**LIGHT  
DUTY  
TRUCK**

**SERVICE  
MANUAL**

## FOREWORD

This manual includes theory of operation and procedures for diagnosis, maintenance and adjustments, minor service operations, and removal and installation for components of Chevrolet Light Duty Trucks. Procedures involving disassembly and assembly of major components for these vehicles are contained in the 1974 Chevrolet Passenger Car and Light Duty Truck Overhaul Manual. Wiring diagrams for 1974 trucks are contained in a separate Wiring Diagram Booklet.

The Section Index on the contents page enables the user to quickly locate any desired section. At the beginning of each section containing more than one major subject is a Table of Contents, which gives the page number on which each major subject begins. An Index is placed at the beginning of each major subject within the section.

Summaries of Special Tools, when required, are found at the end of major sections while specifications covering vehicle components are presented at the rear of the manual.

This manual should be kept in a handy place for ready reference. If properly used, it will enable the technician to better serve the owners of Chevrolet built vehicles.

All information, illustrations and specifications contained in this literature are based on the latest product information available at the time of publication approval. The right is reserved to make changes at any time without notice.

*March 1980*

**CHEVROLET MOTOR DIVISION**  
General Motors Corporation  
DETROIT, MICHIGAN

# 1974 LIGHT DUTY TRUCK

(SERIES 10-30)

## CHASSIS SERVICE MANUAL

SECTION INDEX	
SECTION	NAME
<b>0</b>	GENERAL INFORMATION AND LUBRICATION
<b>1A</b>	HEATER AND AIR CONDITIONING
<b>1B</b>	BODY
<b>2</b>	FRAME
<b>3</b>	FRONT SUSPENSION 4-WHEEL DRIVE
<b>4</b>	REAR SUSPENSION AND DRIVELINE
<b>5</b>	BRAKES
<b>6</b>	ENGINE
<b>6K</b>	ENGINE COOLING
<b>6M</b>	FUEL SYSTEM
<b>6T</b>	EMISSION CONTROL SYSTEMS
<b>6Y</b>	ENGINE ELECTRICAL
<b>7M</b>	CLUTCH AND MANUAL TRANSMISSION
<b>7A</b>	AUTOMATIC TRANSMISSION
<b>8</b>	FUEL TANK AND EXHAUST SYSTEM
<b>9</b>	STEERING
<b>10</b>	WHEELS AND TIRES
<b>11</b>	CHASSIS SHEET METAL
<b>12</b>	ELECTRICAL—BODY AND CHASSIS
<b>13</b>	RADIATOR AND GRILLE
<b>14</b>	BUMPERS
<b>15</b>	ACCESSORIES
	SPECIFICATIONS

[classiccaryllibrary.com](http://classiccaryllibrary.com)

# SECTION 0

## GENERAL INFORMATION AND LUBRICATION

### CONTENTS OF THIS SECTION

General Information .....	0-1
Lubrication.....	0-5

## GENERAL INFORMATION

### INDEX

Model Line Up .....	0-1	Service Parts Identification Plate .....	0-3
Truck Model Designation .....	0-1	Keys and Locks.....	0-3
Vehicle Identification Number and Rating Plate....	0-1	Emergency Starting .....	0-3
Engine Number.....	0-2	Towing .....	0-4
Unit and Serial Number Locations.....	0-2		

### MODEL LINE UP

The 10 through 35 Series truck model line-up for 1974 consists of the models shown in the Charts in this section.

### Truck Model Designation

A five digit number preceded by a letter is used to designate truck models. For example, vehicle C 10703 would be: Conventional C, 4900 lbs.-6800 lbs. GVW 1, 42 in. -47 in. Cab-to-Axle dimension 07, Chassis cab 03, as listed below.

#### First Letter - Chassis

- C - Conventional (Conventional Cab, Suburban)
- G - Light Duty Forward Control
- K - Four-Wheel Drive
- P - Forward Control

#### First Number-GVW Range

- 1 - 4500-7150 lbs.
- 2 - 5500-8200 lbs.
- 3 - 6200-14000 lbs.

#### Second and Third Numbers- Cab-To-Axle Dimension

- 05 - 30-35 in.
- 07 - 42-47 in.

- 08 - 48-53 in.
- 09 - 54-59 in.
- 10 - 60-65 in.
- 14 - 84-89 in.

#### Fourth and Fifth Numbers-Body Styles

- Pickup boxes, tailgate and drop glass, van bodies, and trim are options.
- 03 - Cab
  - 05 - Van (windowless)
  - 06 - Suburban and Van (with windows)
  - 14 - Utility
  - 32 - Motor Home Chassis
  - 42 - Forward Control Chassis
  - 63 - Four-Door Crew Cab

### VEHICLE IDENTIFICATION NUMBER AND RATING PLATE

A combination vehicle identification number and rating plate used on all models (fig. 1) is located on the left door pillar of CK models. On Forward Control models (except P30 Motor Home Chassis) it is attached to the dash and toe panel.

The vehicle identification number stamped on the plate decodes into the information shown in Figure 2.

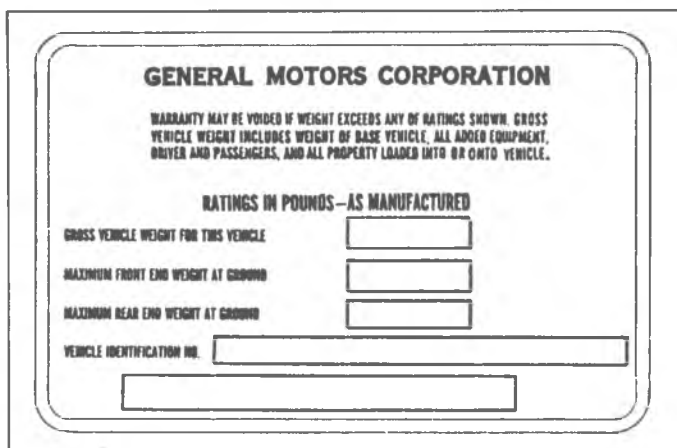

Fig. 1—Vehicle Identification Number and Rating Plate Information

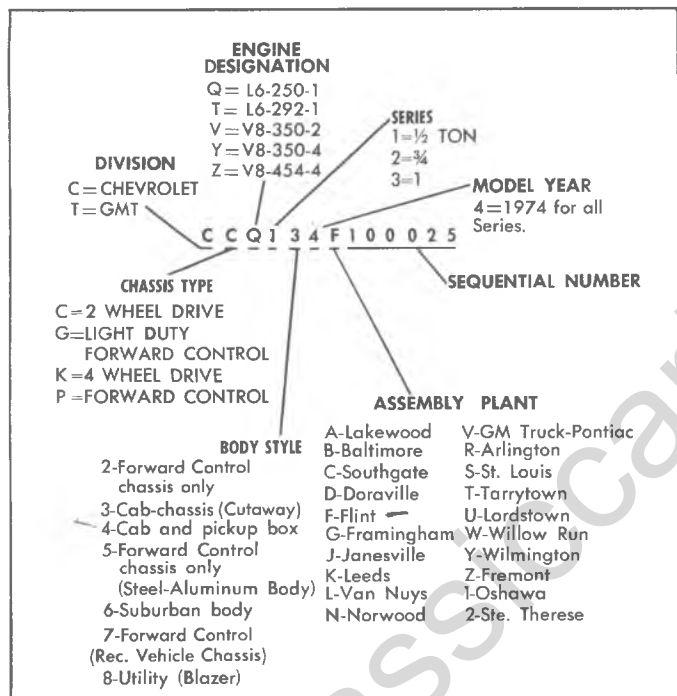

Fig. 2—Vehicle Identification Number

**ENGINE NUMBER**

The engine number indicates manufacturing plant, month and day of manufacture, and transmission type. A typical engine number would be F1210TFA, which would breakdown thus:

- F - Manufacturing Plant (F-Flint, T-Tonawanda)
- 12 - Month of Manufacture (December)
- 10 - Day of Manufacture (tenth)
- T - Truck
- FA - Transmission and engine type

**UNIT AND SERIAL NUMBER LOCATIONS**

For the convenience of service technicians and engineers when writing up certain business papers such as Warranty Reports, Product Information Reports, or reporting product failures in any way, the location of the various unit numbers have been indicated. These unit numbers and their prefix or suffix are necessary on these papers for various reasons - such as accounting, follow-up on production, etc.

The prefixes on certain units identify the plant in which the unit was manufactured and thereby permits proper follow-up of the plant involved to get corrections made when necessary.

Always include the prefix in the number.

**Axles**

- Series 10, 20 and P30 Code is stamped on Front of Right Rear Axle Tube Inboard of Upper Control Arm Bracket.
- Series CG30 (except dual wheel) code is stamped at the Forward Upper Surface of Carrier.
- Dual Wheel Part Number and Production Code is stamped on Front of Right Axle Tube.

**Transmissions**

- 3-Speed Transmission Unit Number Located on Lower Left Side of Case Adjacent to Rear of Cover.
- 4-Speed Transmission Unit Number Stamped on Rear of Case, Above Output.
- Turbo Hydra-Matic 350 Transmission Unit Number Located on Right Rear Vertical Surface of Oil Pan.
- The Turbo Hydra-Matic Transmission 400 Serial Number is Located on the Light Blue Plate on the Right Side of the Transmission.

**Engines**

- 6-Cylinder Engine Unit Number Located on Pad at Right Hand Side of Cylinder Block at Rear of Distributor.
- 8-Cylinder Engine Unit Number Located on Pad at Front, Right Hand Side of Cylinder Block.

**Delcotrons**

Delcotron Unit Serial Number Located at Top of Rear Housing.

**Batteries**

Battery Code Number Located on Cell Cover Top of Battery.

**Starters**

Starter Serial Number and Production Date Stamped on Outer Case, Toward Rear.

SERVICE PARTS IDENTIFICATION			
V.I.N.	W/BASE	SE	
VIN - VEHICLE IDENTIFICATION NUMBER			
NOTE: THE SPECIAL EQUIPMENT LISTED BELOW HAS BEEN INSTALLED ON THIS VEHICLE FOR PROPER IDENTIFICATION OF REPLACEMENT PARTS. BE SURE TO SPECIFY THE APPLICABLE OPTION NUMBER.			
DESCRIPTION	OPTION NO.	DESCRIPTION	
<b>IMPORTANT: RETAIN THIS PLATE AS A PERMANENT RECORD</b>			

Fig. 3—Service Parts Identification Plate

## SERVICE PARTS IDENTIFICATION PLATE

The Service Parts Identification Plate (fig. 3) is provided on all Truck models. On most series it will be located on the inside of the glove box door, or, on Forward Control series, it will be located on an inner body panel. The plate lists the vehicle serial number, wheelbase, and all Production options or Special Equipment on the vehicle when it was shipped from the factory including paint information. **ALWAYS REFER TO THIS INFORMATION WHEN ORDERING PARTS.**

## KEYS AND LOCKS

Two keys are provided with each vehicle. Different lock cylinders operated by a separate key are available as an option for the sliding side load door and rear load doors.

## EMERGENCY STARTING

- Engines in vehicles with automatic transmissions cannot be started by pushing or towing the vehicle.
- Never tow a manual transmission - equipped vehicle to start because the surge forward when the engine starts could cause a collision with the tow vehicle.
- A car with a discharged battery may be started by transferring electrical power from a battery in another car - called "jump starting".

## Jump Starting

The following procedure is for use **ONLY** under the following conditions. Departures from these conditions and procedures, could result in: (1) serious personal injury (particularly to eyes) or property damage from such things as battery explosion, battery acid or electrical burns, or (2) damage to electronic components in either vehicle. If all the conditions cannot be met, or if you are uncertain about them, we strongly recommend for your safety and that of your vehicle that you leave the starting to a competent mechanic.

- The battery in the other vehicle must be of the **same nominal voltage**, 12 volts, and must be **negatively grounded**. (All General Motors cars, light trucks (10,000 GVWR and under), and motor homes use 12-volt, negatively grounded electrical systems and can be used to jump start one another.) The nominal voltage and grounding of the other vehicle's battery may be determined by checking the specifications in its owner's manual. Use of a booster battery of a higher nominal voltage, or which is positively grounded may result in serious personal injury or property damage.

**CAUTION:** *Never expose battery to open flame or electric spark - battery action generates hydrogen gas which is flammable and explosive. Don't allow battery fluid to contact eyes, skin, fabrics, or painted surfaces - fluid is a sulfuric acid solution which could cause serious personal injury or property damage. Flush any contacted area immediately with water. Wear eye protection such as industrial safety spectacles or goggles when working on or near battery.* Remove rings, metal watch bands and other metal jewelry before jump starting or working around a battery. Be careful in using metal tools and equipment. If such metal should contact the positive battery terminal (or metal in contact with it) and any other metal on the vehicle, a short circuit may occur which could cause personal injury. Batteries and battery acid should always be kept out of reach of children.

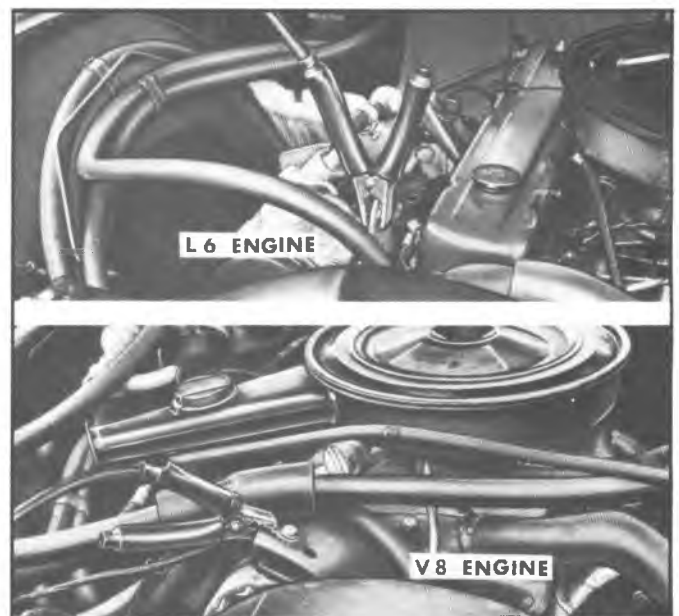

Fig. 4—Booster Battery Cable Ground Connection

## 0-4 GENERAL INFORMATION AND LUBRICATION

### To Jump Start:

1. Position the two vehicles so they are **not** touching. Set parking brake and place automatic transmission in "PARK" (neutral for manual transmission) in each vehicle. Also turn off lights, heater and all other unnecessary electrical loads.
2. Remove vent caps from both the booster and the discharged batteries. Lay a cloth over the open vent wells of each battery. These two actions help reduce the explosion hazard always present in either battery when connecting "live" booster batteries to "dead" batteries.
3. Attach one end of one jumper cable to the positive terminal of the **booster battery** (identified by a red color, "+" or "P" on the battery case, post or clamp) and the other end of same cable to positive terminal of **discharged battery**.
4. Attach one end of the remaining negative cable to the negative terminal (black color, "-" or "N" of the **booster battery**, and the other end to the engine lift bracket on 6 cylinder models or the delcotron mounting bracket on 8 cylinder models (**do not connect directly to negative post** of dead battery) - taking care that clamps from one cable do not inadvertently touch the clamps on the other cable. Do not lean over the battery when making this connection.
5. Start the engine in the vehicle that is providing the jump start (if it was not running). Let run a few minutes, then start the engine in the vehicle with the discharged battery.
6. Reverse the above sequence exactly when removing the jumper cables. Reinstall vent caps and dispose in a safe manner any cloths used to cover vent wells, as the cloths may have corrosive acid on them.

### PUSH STARTING

If your truck is equipped with a manual 3-speed or 4-speed transmission, it can be started in an emergency by pushing. When being pushed to start the engine, turn off all unnecessary electrical loads, turn ignition to "ON," depress the clutch pedal and place the shift lever in high gear. Release the clutch pedal when speed reaches 10 to 15 miles per hour. Bumpers and other parts contacted by the pushing vehicle should be protected from damage during pushing. Never tow the truck to start.

### TOWING

#### All Except Four Wheel Drive Trucks

Normally your vehicle may be towed with all four wheels

on the ground for distances up to 50 miles at speeds of less than 35 MPH. The engine should be off and the transmission in neutral.

However, the rear wheels must be raised off the ground or the drive shaft disconnected when the transmission is not operating properly or when a speed of 35 MPH or distance of 50 miles will be exceeded.

**CAUTION:** *If a truck is towed on its front wheels only, the steering wheel must be secured with the wheels in a straight ahead position.*

#### Four Wheel Drive Trucks

It is recommended that the truck be towed with the front wheels off the ground. The truck can be towed, however, with the rear wheels off the ground if there is damage in the rear wheel area. In this event, the transmission selector lever should be placed in the "N" (neutral) position and with conventional four wheel drive the front drive disengaged. With Full Time four wheel drive the transfer case should be in high. Towing speeds should not exceed 35 MPH for distances up to 50 miles. If truck is towed on its front wheels, the steering wheel should be secured to keep the front wheels in a straight-ahead position.

When towing the vehicle at slow speeds (approx. 20 MPH), for a very short distance only, the transmission must be in NEUTRAL and with conventional four wheel drive the transfer case **MUST** be in "TWO WHEEL HIGH." With Full Time four wheel drive the transfer case should be in high.

When towing the vehicle at faster speeds for greater distances, the following steps **MUST** be taken:

- If front wheels are on the road, disconnect the front drive shaft.
- If rear wheels are on the road, disconnect the rear drive shaft.

### STEEL TUBING REPLACEMENT

In the event that replacement of steel tubing is required on brake line, fuel line, evaporative emission, and transmission cooling lines, only the recommended steel replacement tubing should be used.

Only special steel tubing should be used to replace brake line. That is, a double wrapped and brazed steel tubing meeting G.M. Specification 123 M. Further, any other steel tubing should be replaced only with the released steel tubing or its equivalent. Under no condition should copper or aluminum tubing be used to replace steel tubing. Those materials do not have satisfactory fatigue durability to withstand normal vehicle vibrations.

All steel tubing should be flared using the upset (double lap) flare method which is detailed in Section 5 of this Manual.



**VEHICLE LOADING**

Vehicle loading must be controlled so weights do not exceed the numbers shown on the Vehicle Identification Number and Rating Plate for the vehicle.

In trailer hauling applications, the vehicle rear end weight at the ground with trailer attached must not exceed the "Maximum Rear End Weight at Ground" rating of the vehicle.

A typical example of a truck in a loaded condition is shown in Figure 5. Note that the axle or GVW capabilities are not exceeded.

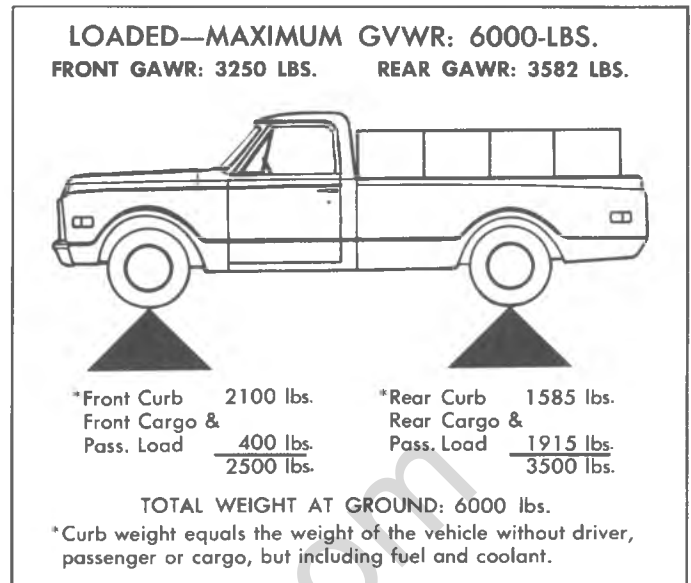

Fig. 5—Typical Vehicle Loaded Condition

**LUBRICATION**

**INDEX**

Maintenance Schedule .....	0-5	Wheel Bearings	
Engine .....	0-6	Front .....	0-8
Oil and Filter Recommendations .....	0-6	Rear .....	0-8
Drive Belts .....	0-7	Brake Master Cylinder .....	0-9
Positive Crankcase Ventilation .....	0-7	Brake and Clutch Pedal Springs .....	0-9
Air Injection Reactor System .....	0-7	Parking Brake .....	0-9
Controlled Combustion System .....	0-7	Steering	
GM Evaporation Control System .....	0-7	Manual Steering Gear .....	0-9
Manifold Heat Control Valve .....	0-7	Steering Linkage and Suspension .....	0-9
Air Cleaner .....	0-7	Hood Latch and Hood Hinge .....	0-9
Fuel Filter .....	0-7	Body Lubrication .....	0-9
Distributor .....	0-7	Four Wheel Drive	
Governor .....	0-7	Propeller Shaft Centering Ball .....	0-10
Accelerator Linkage .....	0-7	Front Axle .....	0-10
Automatic Transmission Fluid Recommendations .....	0-7	Air Vent Hose .....	0-10
Manual Transmission .....	0-8	Transfer Case .....	0-10
Transmission Shift Linkage .....	0-8	Control Lever and Linkage .....	0-10
Clutch .....	0-8	Speedometer Adapter .....	0-10
Rear Axle		Extended Vehicle Storage .....	0-10
Standard .....	0-8	Lubrication Diagrams	
Propeller Shaft Slip Joints .....	0-8	Conventional and Forward Control Models .....	0-17
Universal Joints .....	0-8	Four Wheel Drive Models .....	0-18
		1/2, 3/4 and 1 ton G Models .....	0-19

**MAINTENANCE SCHEDULE**

A separate maintenance folder has been provided with each vehicle which contains a complete schedule and brief explanation of the safety, emission control, lubrication and general maintenance it requires. The

maintenance folder information is supplemented by this section of this manual, as well as the separate emission control systems folder also furnished with each vehicle. Read all three publications for a full understanding of vehicle maintenance requirements.

## 0-6 GENERAL INFORMATION AND LUBRICATION

The time or mileage intervals for lubrication and maintenance services outlined in this section are intended as a general guide for establishing regular maintenance and lubrication periods. Sustained heavy duty and high speed operation or operation under adverse conditions may require more frequent servicing.

### ENGINE

#### Oil & Filter Recommendations

The letter designation "SE" has been established to correspond with the requirements of GM 6136-M. "SE" engine oils will be better quality and perform better than those identified with "SA" through "SD" designations and are recommended for all light-duty gasoline trucks regardless of model year and previous engine oil quality recommendations.

#### Oil Change Period

- Use only SE engine oil.
- Change oil each 4 months or 6,000 miles. If more than 6,000 miles are driven in a 4-month period, change oil each 6,000 miles.
- Change oil each 2 months or 3,000 miles, whichever occurs first, under the following conditions:
  - Driving in dusty conditions
  - Trailer pulling or camper use.
  - Frequent long runs at high speeds and high ambient temperatures.
  - Motor Home use.
  - Stop and go type service such as delivery trucks, etc.
  - Extensive idling
  - Short-trip operation at freezing temperatures (engine not thoroughly warmed-up).
- Operation in dust storms may require an immediate oil change.
- Replace the oil filter at the first oil change, and every second oil change thereafter. AC oil filters provide excellent engine protection.

The above recommendations apply to the first change as well as subsequent oil changes. The oil change interval for the engine is based on the use of SE oils and quality oil filters. Oil change intervals longer than those listed above will seriously reduce engine life and may affect the manufacturer's obligation under the provisions of the New Vehicle Warranty.

A high quality SE oil was installed in the engine at the factory. It is not necessary to change this factory-installed oil prior to the recommended normal change period. However, check the oil level more frequently during the break-in period since higher oil consumption is normal until the piston rings become seated.

NOTE: Non-detergent and other low quality oils are specifically not recommended.

#### Oil Filter Type and Capacity

- Throwaway type, 1 quart U.S. measure, .75 quart Imperial measure.
- 250 cu. in., 292 cu. in., AC Type PF-25. 350 cu. in. 454 cu. in., AC Type PF-35.

#### Crankcase Capacity (Does Not Include Filter)

- 292 L6 Engine; 5 quarts U.S. measure, 4.25 quarts Imperial measure.
- All other engines; 4 quarts U.S. measure, 3.25 quarts Imperial measure.

#### Recommended Viscosity

Select the proper oil viscosity from the following chart:

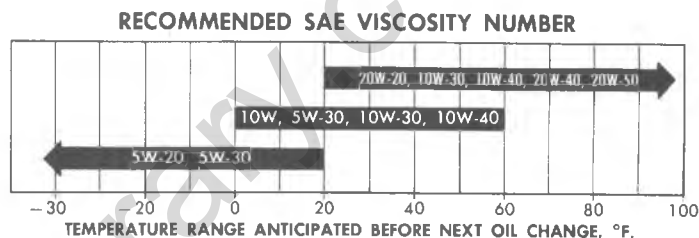

NOTE: SAE 5W-20 oils are not recommended for sustained high-speed driving. SAE 30 oils may be used at temperatures above 40°F. SAE 5W-30 oils are recommended for all seasons in vehicles normally operated in Canada.

The proper oil viscosity helps assure good cold and hot starting.

#### Checking Oil Level

The engine oil should be maintained at proper level. The best time to check it is before operating the engine or as the last step in a fuel stop. This will allow the oil accumulation in the engine to drain back in the crankcase. To check the level, remove the oil gauge rod (dip stick), wipe it clean and reinsert it firmly for an accurate reading. The oil gauge rod is marked "FULL" and "ADD OIL". If the oil is at or below the "ADD" mark on the dipstick, oil should be added as necessary. The oil level should be maintained in the safety margin, neither going above the "FULL" line nor below "ADD OIL" line.

NOTE: The oil gauge rod is also marked "Use SE Engine Oil" as a reminder to use only SE oils.

#### Supplemental Engine Oil Additives

The regular use of supplemental additives is specifically not recommended and will increase operating costs. However, supplemental additives are available that can

effectively and economically solve certain specific problems without causing other difficulties. For example, if higher detergency is required to reduce varnish and sludge deposits resulting from some unusual operational difficulty, a thoroughly tested and approved additive - "Super Engine Oil Supplement"- is available.

### Drive Belts

Drive belts should be checked every 6,000 miles or 4 months for proper tension. A loose belt will affect water pump and generator operation.

### POSITIVE CRANKCASE VENTILATION VALVE

Every 24,000 miles or 24 months the valve should be replaced. Connecting hoses, fittings and flame arrestor should be cleaned. At every oil change the system should be tested for proper function and serviced, if necessary.

### AIR INJECTION REACTOR SYSTEM (A.I.R.) CONTROLLED COMBUSTION SYSTEM (C.C.S.)

The Air Injection Reactor system should have the drive belt inspected for wear and tension every 4 months or 6,000 miles, whichever occurs first. In addition, complete effectiveness of either system, as well as full power and performance, depends upon idle speed, ignition timing, and idle fuel mixture being set according to specification. A quality tune-up which includes these adjustments should be performed periodically to assure normal engine efficiency, operation and performance.

### EXHAUST GAS RECIRCULATION SYSTEM (EGR) -

At 12-month/12,000 mile intervals when operating with leaded fuels or at 24-month/24,000 mile intervals when using unleaded fuels remove, inspect, and if deposits exist, clean the EGR valve. Inspect the EGR passages in the inlet manifold and clean as required. A damaged EGR valve must be repaired or replaced.

### GM EVAPORATION CONTROL SYSTEM

Every 24 months or 24,000 miles (more often under dusty conditions) the filter in the base of the canister must be replaced and the canister inspected.

### MANIFOLD HEAT CONTROL VALVE

First 6,000 miles and every 12,000 miles or 12 months thereafter check valve for freedom of operation. If valve shaft is sticking, free it up with GM Manifold Heat Control Solvent or its equivalent.

### AIR CLEANER

**CAUTION:** Do not remove the engine air cleaner unless temporary removal is necessary during repair or maintenance of the vehicle.

*When the air cleaner is removed backfiring can cause fire in the engine compartment.*

**NOTE:** Under prolonged dusty driving conditions, it is recommended that these operations be performed more often.

### Oil Wetted Paper Element Type

L-6 engine, replace every 12,000 miles. V-8 engine, every 12,000 miles inspect element for dust leaks, holes or other damage. Replace if necessary. If satisfactory, rotate element 180° from originally installed position. Replace at 24,000 miles. Element must not be washed, oiled, tapped or cleaned with an air hose.

### Crankcase Ventilation Filter (Located Within Air Cleaner)

If so equipped, inspect every oil change and replace if necessary. Replace at least every 24,000 miles; more often under dusty driving conditions.

### FUEL FILTER

Replace filter element located in carburetor inlet every 12 months or 12,000 miles whichever occurs first, or, if an in-line filter is also used, every 24,000 miles. Replace in-line filter every 24,000 miles.

### DISTRIBUTOR

Replace cam lubricator at 24,000 mile intervals.

### GOVERNOR

The attaching bolts should be kept tight, the optionally available governor should be kept clean externally and the filter element should be replaced every 12,000 miles.

### ACCELERATOR LINKAGE

Lubricate with engine oil every 24,000 miles as follows:

1. On V8 engine, lubricate the ball stud at the carburetor lever.
2. On L6 engine, lubricate the two ball studs at the carburetor lever and lubricate the lever mounting stud. Do not lubricate the accelerator cable.

### AUTOMATIC TRANSMISSION FLUID RECOMMENDATION

Use only automatic transmission fluids identified with the mark **DEXRON®-II** or **DEXRON®** (or equivalent).

Check the fluid level at each engine oil change period. To make an accurate fluid level check:

1. Drive vehicle several miles, making frequent starts and stops, to bring transmission up to normal operating temperature (approximately 180-190°F).
2. Park vehicle on a level surface.
3. Place selector lever in "Park" and leave engine running.

## 0-8 GENERAL INFORMATION AND LUBRICATION

4. Remove dipstick and wipe clean.
5. Reinsert dipstick until cap seats.
6. Remove dipstick and note reading.

If oil level is at or below the ADD mark on the dipstick, oil should be added as necessary. One pint raises the level from ADD to FULL. **Do not overfill.**

Under normal driving conditions, the transmission fluid should be changed every 24,000 miles. If the vehicle is driven extensively in heavy city traffic during hot weather, or is used to pull a trailer, change fluid every 12,000 miles. Likewise, operators of trucks in commercial use where the engine idles for long periods, should change fluid every 12,000 miles.

**To Change Turbo Hydra-Matic 400 and Turbo Hydra-Matic 350 fluid,** remove fluid from the transmission sump, add approximately 7.5 pints U.S. measure (6.25 pints Imperial measure) for the Turbo Hydra-Matic 400 and 2 1/2 qts. U.S. measure (2 qts. Imperial measure) for the Turbo Hydra-Matic 350 of fresh fluid, to return level to proper mark on the dipstick.

**Every 24,000 Miles**—the Turbo Hydra-Matic 400 transmission sump filter should be replaced.

### 3-AND 4-SPEED MANUAL TRANSMISSION LUBRICANT

Every 4 months or 6,000 miles, whichever occurs first, check lubricant level and add lubricant, if necessary, to fill to level of filler plug hole with SAE 80 or SAE 90 GL-5 Gear Lubricant. If temperatures below +32°F are expected, use SAE 80 GL-5 Gear Lubricant only.

For those vehicles normally operated in Canada, use SAE 80 GL-5 Gear Lubricant.

### TRANSMISSION SHIFT LINKAGE (MANUAL AND AUTOMATIC)

Every 6,000 miles or 4 months-lubricate shift linkage and, on Manual transmission floor control, lever contacting faces with water resistant EP chassis lubricant which meets General Motors Specification GM6031-M.

#### Clutch

The clutch pedal free travel should be checked at regular intervals.

Lubricate the clutch cross-shaft at fitting (on Series 10 Forward Control models also lubricate the clutch linkage idler lever at fitting) every 6,000 miles or 4 months with water resistant EP chassis lubricant which meets General Motors Specification GM 6031-M.

### REAR AXLES

#### Standard

Every 4 months or 6,000 miles, whichever occurs first, check lubricant level and add lubricant, if necessary, to fill to level of filler plug hole. Use GL-5 Gear Lubricant

as shown in the following table. (For vehicles normally operated in Canada, use SAE 80 GL-5 Gear Lubricant.)

Outside Temperature	Viscosity Lubricant To Be Used
BELOW 10°F	SAE 80
UP TO 100°F	SAE 90
ABOVE 100°F CONSISTENTLY	SAE 140

On 20 or 30 Series trucks, drain lubricant every 24,000 miles. If vehicle is operated in exceptionally heavy work or at continuous high speeds, the lubricant should be changed every 12,000 miles. It may be necessary to change lubricant more often if vehicle is used off road in dusty areas.

### PROPELLER SHAFT SLIP JOINTS

Propeller shaft slip joints should be lubricated every 6,000 miles or 4 months with water resistant EP chassis lubricant which meets General Motors Specification GM 6031-M.

### UNIVERSAL JOINTS

All universal joints are the needle bearing type. Lubricate those universal joints (depending on truck model) equipped with lube fittings every 6,000 miles or 4 months with water resistant EP chassis lubricant which meets General Motors Specification GM 6031-M. More frequent lubes may be required on heavy duty or "Off the Road" operations.

### WHEEL BEARINGS

#### Front

NOTE: Use wheel bearing lubricant GM Part No. 1051344 or equivalent. This is a premium high melting point lubricant which meets all requirements of General Motors Specification GM 6031-M.

Due to the weight of the tire and wheel assembly it is recommended that they be removed from hub before lubricating bearings to prevent damage to oil seal. Then remove the front wheel hub to lubricate the bearings. The bearings should be thoroughly cleaned before repacking with lubricant.

Front wheels are equipped with tapered roller bearings on all trucks. Wheel bearings should be lubricated every 24,000 miles. Do not mix wheel bearing lubricants.

**CAUTION:** "Long fibre" type greases should not be used on roller bearing front wheels.

#### Rear

The rear wheel bearings receive their lubrication from the rear axle. When installing bearings which have been cleaned, prelube with wheel bearing grease.

## BRAKE MASTER CYLINDER

Check master cylinder fluid level in both reservoirs every 6,000 miles or 4 months. If the fluid is low in the reservoir, it should be filled to a point about 1/4" from the top rear of each reservoir with Delco Supreme No. 11 Hydraulic Brake Fluid or equivalent.

## BRAKE AND CLUTCH PEDAL SPRINGS

Lubricate brake and clutch pedal springs every 6,000 miles or 4 months with engine oil for all models.

## PARKING BRAKE

Every 6,000 miles or 4 months clean and lubricate all parking brake pivot points with water resistant EP chassis lubricant which meets General Motors Specification GM 6031-M.

## STEERING

### Manual Steering Gear

The steering gear is factory-filled with steering gear lubricant. Seasonal change of this lubricant should not be performed and the housing should not be drained—no lubrication is required for the life of the steering gear.

Every 36,000 miles, the gear should be inspected for seal leakage (actual solid grease—not just oily film). If a seal is replaced or the gear is overhauled, the gear housing should be refilled with No. 1051052 (13 oz. container) Steering Gear Lubricant which meets GM Specification GM 4673-M, or its equivalent.

**NOTE:** Do not use EP Chassis Lube, which meets GM Specification GM 6031-M, to lubricate the gear. **DO NOT OVER-FILL** the gear housing.

**NOTE:** Lubricate intermediate steering shaft with water resistant EP chassis lubricant which meets General Motors Specification GM 6031-M every 6,000 miles or 4 months on P-10 models only.

### Power Steering System

Check the fluid level in the pump reservoir at each oil change period. Add GM Power Steering Fluid or **DEXRON®** automatic Transmission Fluid or equivalent as necessary to bring level into proper range on filler cap indicator depending upon fluid temperature.

If at operating temperature (approximately 150°F—hot to the touch), fluid should be between "HOT" and "COLD" marks.

If at room temperature (approximately 70°F), fluid should be between "ADD" and "COLD" marks. Fluid does not require periodic changing.

## STEERING LINKAGE AND SUSPENSION

Maintain correct front end alignment to provide easy steering, longer tire life, and driving stability.

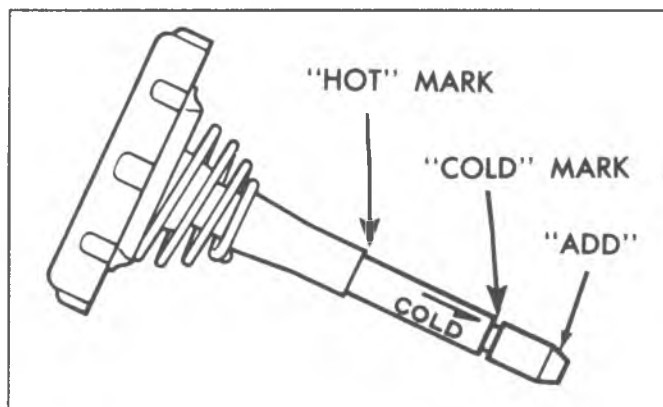

Fig. 6—Power Steering Fluid Level

Check control arm bushings and ball joints for wear.

Lubricate tie rods, upper and lower control arms, and ball joints at fittings with water resistant EP chassis lubricant which meets General Motors Specification GM 6031-M every 6,000 miles or 4 months.

Lubricate every 3,000 miles or 2 months whichever occurs first under the following conditions:

- Driving in dusty or muddy conditions.
- Extensive off-road use.

**NOTE:** Ball joints must be at +10°F. or more before lubricating.

Keep spring to axle U bolts and shackle bolts properly tightened (see Specifications Section for torque recommendations). Check U bolt nuts after the first 1,000 miles of operation if the U bolt or U bolt nuts are changed in service.

## HOOD LATCH AND HOOD HINGE

Every 6,000 miles or 4 months, whichever occurs first, lubricate hood latch assembly and hood hinge assembly as follows:

1. Wipe off any accumulation of dirt or contamination on latch parts.
2. Apply Lubriplate or equivalent to latch pilot bolt and latch locking plate.
3. Apply light engine oil to all pivot points in release mechanism, as well as primary and secondary latch mechanisms.
4. Lubricate hood hinges.
5. Make hood hinge and latch mechanism functional check to assure the assembly is working correctly.

## BODY LUBRICATION

Normal use of a truck causes metal-to-metal movement at certain points in the cab or body. Noise, wear and improper operation at these points will result when a protective film of lubricant is not provided.

## O-10 GENERAL INFORMATION AND LUBRICATION

For exposed surfaces, such as door checks, door lock bolts, lock striker plates, dovetail bumper wedges, etc., apply a thin film of light engine oil.

Where oil holes are provided in body parts a dripless oil can be safely used, but any lubricant should be used sparingly, and after application all excess should be carefully wiped off.

The seat adjusters and seat track, ordinarily overlooked, should be lubricated with water resistant EP chassis lubricant which meets General Motors Specification GM 6031-M.

There are other points on bodies which may occasionally require lubrication and which are difficult to service. Window regulators and controls are confined in the space between the upholstery and the outside door panel. Easy access to the working parts may be made by removing the trim. Door weatherstrips and rubber hood bumpers should be lightly coated with a rubber lubricant.

### UNDERBODY MAINTENANCE

The effects of salt and other corrosive materials used for ice and snow removal and dust control can result in accelerated rusting and deterioration of underbody components such as brake and fuel lines, frame, underbody floor pan, exhaust system, brackets, parking brake cables. These corrosive effects, however, can be reduced by periodic flushing of the underbody with plain water. In geographic areas having a heavy concentration of such corrosive materials, it is recommended that the complete underbody be inspected and flushed at least once a year, preferably after a winter's exposure. Particular attention should be given to cleaning out underbody members where dirt and other foreign materials may have collected.

### FOUR WHEEL DRIVE

Most lubrication recommendations and procedures for 4 wheel drive-equipped trucks are the same for corresponding components of conventional drive trucks.

In addition, the following items require lubrication at the intervals mentioned.

#### Propeller Shaft Centering Ball

A centering ball at the transfer case end of the front propeller shaft on Four Wheel Drive Models should be lubricated every 6,000 miles with water resistant EP chassis lubricant which meets General Motors Specification GM 6031-M. More frequent lubrication may be required on heavy duty off the road operations.

NOTE: A special needle nose grease gun adapter for flush type grease fitting is required to lubricate the centering ball.

#### Front Axle

The front axle should be checked every 6,000 miles or 4 months and refilled with SAE 90 GL-5 Gear Lubricant when necessary. With the differential at operating temperature, fill to the level of filler plug hole. If differential is cold, fill to level of 1/2" below the filler plug hole. For vehicles normally operated in Canada use SAE 80 GL-5 Gear Lubricant.

#### Air Vent Hoses

Check vent hose at front axle and at transfer case for kinks and proper installation every 6,000 miles or 4 months.

#### Transfer Case

Check the transfer case level every 6,000 miles or 4 months and, if necessary, add lubricant as follows:

##### *Conventional Four Wheel Drive*

Add SAE 80 or SAE 90 GL-5 Gear Lubricant to bring to level of filler plug hole.

##### *Full Time Four Wheel Drive*

Add SAE 10W-30 or SAE 10W-40 engine oil to bring to level 1/2" below filler plug hole.

#### Control Lever and Linkage

Since no grease fitting is provided in the control lever it is necessary to brush or spray engine oil on the lever pivot point and on all exposed control linkage every 6,000 miles or 4 months.

### SPEEDOMETER ADAPTER

On vehicles so equipped, lubricate adapter at fitting with water resistant EP chassis grease which meets General Motors Specification GM 6031-M every 6,000 miles.

## COMPLETE VEHICLE MAINTENANCE SCHEDULE

When To Perform Services (Months or Miles, Whichever Occurs First)	Item No.	Services (For Details, See Numbered Paragraphs)	
Every 4 months or 6,000 miles	1	Chassis Lubrication	
	2	*^Fluid Levels	
	3	*Engine Oil	
	4	Air Conditioning System	
Every 6,000 miles	5	Tire Rotation	
At 1st oil change—then every 2nd	6	*Engine Oil Filter	
Every 12,000 miles	7	Rear Axle	
Every 12 months or 12,000 miles	8	*Cooling System	
Every 24,000 miles	9	Wheel Bearings	
	10	*Automatic Transmission	
Every 36,000 miles	11	Manual Steering Gear	
Every 4 months or 6,000 miles	12	Owner Safety Checks	
	13	Tires and Wheels	
	14	Exhaust System	
	15	*Drive Belts	
	16	Suspension and Steering	
	17	Brakes and Power Steering	
Every 6,000 miles	18	Disc Brakes	
Every 12 months or 12,000 miles	19	Drum Brakes and Parking Brake	
	20	Throttle Linkage	
	21	Headlights	
	22	Underbody	
At 1st 4 months or 6,000 miles— then at 12 month/12,000 mile intervals	23	Thermostatically Controlled Air Cleaner	
	24	Carburetor Choke	
	25	Timing, Dwell, Carb. Idle, Distr. and Coil	
	26	Manifold Heat Valve	
At 1st 4 months or 6,000 miles	27	Carburetor Mounting	
Every 6,000 miles	28	Spark Plugs (Vehicles using leaded fuels)	
Every 12 months or 12,000 miles	29	EGR System (Vehicles using leaded fuels)	
	30	Carburetor Fuel Inlet Filter	
	31	Thermal Vacuum Switch and Hoses	
	32	Vacuum Advance Solenoid and Hoses	
	33	Transmission Control Switch	
	34	Idle Stop Solenoid	
	35	PCV System	
	Every 24 months or 24,000 miles	36	Engine Compression
		37	ECS System
38		Fuel Cap, Tank and Lines	
39		AIR System	
Every 24,000 miles	40	Air Cleaner Element	
At 1st 24/24—then every 12/12	41	Spark Plug and Ignition Coil Wires	

\*Also an Emission Control Service

^Also a Safety Service

## EXPLANATION OF COMPLETE VEHICLE MAINTENANCE SCHEDULE

Presented below is a brief explanation of each of the services listed in the preceding Complete Vehicle Maintenance Schedule.

Vehicle operation under conditions such as heavy dust, continuous short trips, use of other than unleaded or low lead fuels or pulling trailers, is not considered normal use and therefore more frequent maintenance will be required. Such additional maintenance requirements are included where applicable. Refer to the appropriate section of this manual for additional details on specific services. A listing of recommended lubricants and fluids is included at the end of this listing.

### LUBE AND GENERAL MAINTENANCE

1. **CHASSIS**—Lubricate all grease fittings in front suspension, steering linkage, and constant velocity universal joint. Also lubricate transmission shift linkage, hood latch, hood hinges, and parking brake cable guides and linkage, clutch linkage, propeller shaft slip joint, universal joints and brake and clutch pedal springs. Lubricate suspension and steering linkage every 2 months or 3,000 miles when operating under dusty or muddy conditions and in extensive off-road use. (See elsewhere in this section for additional services required on four wheel drive models.)
2. **FLUID LEVELS**—Check level of fluid in brake master cylinder\*, power steering pump\*, battery, engine\*\*, axles, transmission\*\* transfer case and windshield washer\*. Engine coolant should be checked for proper level and freeze protection to at least  $-20^{\circ}\text{F}$  or to the lowest temperature expected during the period of vehicle operation.\*\* Proper engine coolant also provides corrosion protection.

Any significant fluid loss in any of these systems or units could mean that a malfunction is developing and corrective action should be taken immediately. On vehicles with disc brakes, low fluid level in the brake master cylinder front reservoir could also be an indicator that the disc brake pads need replacing.

3. **ENGINE OIL\*\***—Change each 4 months or 6,000 miles, whichever occurs first, or each 2 months or 3,000 miles when the vehicle is operated under the following conditions: (a) driving in dusty conditions, (b) trailer pulling, (c) extensive idling or (d) short-trip operation at freezing temperatures (with engine not thoroughly warmed-up). See elsewhere in this section for additional details on engine oil.

4. **AIR CONDITIONING**—Check condition of air conditioning system hoses and refrigerant charge at sight glass (if so equipped). Replace hoses and/or refrigerant if need is indicated.

5. **TIRES**—To equalize wear, rotate tires and adjust tire pressures as outlined in Section 10 of this manual.

6. **ENGINE OIL FILTER\*\***—Replace at the first oil change and every other oil change thereafter.

7. **REAR AXLE**—Change lubricant at first 12,000 miles on Positraction axles. On 20 30 Series trucks, change lubricant every 24,000 miles. Change lubricant every 12,000 miles on all type rear axles under severe operating conditions.

8. **COOLING SYSTEM**—At 12-month or 12,000 mile intervals, wash radiator cap and filler neck with clean water, pressure test system and radiator cap for proper pressure holding capacity, (tighten hose clamps and inspect condition of all cooling and heater hoses\*\*). Replace hoses every 24 months or 24,000 miles or earlier if checked, swollen or otherwise deteriorated.

Also each 12 months or 12,000 miles, clean exterior of radiator core and air conditioning condenser.\*\* Every 24 months or 24,000 miles, drain, flush, and refill the cooling system with a new coolant solution.\*\*

9. **WHEEL BEARINGS** — Clean and repack front wheel bearings with a lubricant as specified in the "Recommended Fluid and Lubricants" section in this section.

10. **AUTOMATIC TRANSMISSION FLUID\*\***—Under normal driving conditions, change the transmission fluid and service the sump filter every 24,000 miles. Under unusual conditions such as constant driving in heavy city traffic during hot weather, trailer pulling, etc., these services should be performed at 12,000-mile intervals. See elsewhere in this manual for further details on transmission care.

11. **MANUAL STEERING GEAR**—Check for seal leakage around the pitman shaft and housing. If leakage is evident (solid grease oozing out—not just oily film), it should be corrected immediately.

### SAFETY MAINTENANCE

12. **SAFETY CHECKS TO BE PERFORMED BY OWNER**—Listed below are the safety checks that

\*Also a safety Service

\*\*Also an Emission Control Service



should be made by the owner (items a thru u). These checks should be made regularly during operation, at no greater interval than 4 months or 6,000 miles, whichever occurs first, and more often when the need is indicated. Any deficiencies should be brought to the attention of the dealer or another service outlet, as soon as possible.

a. **STEERING COLUMN LOCK (if so equipped)**—Check for proper operation by attempting to turn key to LOCK position in the various transmission gears with vehicle stationary. Key should turn to LOCK position only when transmission control is in PARK on automatic transmission models or in reverse on manual transmission models. Key should be removable only in LOCK position.

b. **PARKING BRAKE AND TRANSMISSION "PARK" MECHANISM**—Check parking brake holding ability by parking on a fairly steep hill and restraining the vehicle with the parking brake only. On vehicles with automatic transmissions, check the holding ability of the "PARK" mechanism by releasing all brakes after the transmission selector lever has been placed in the "P" position.

**CAUTION:** *Before making the two checks below, be sure to have a clear distance ahead and behind the vehicle, set the parking brake and firmly apply the foot brake. Do not depress accelerator pedal. Be prepared to turn off ignition switch immediately if engine should start.*

c. **STARTER SAFETY SWITCH (AUTOMATIC TRANSMISSION)**—Check starter safety switch by placing the transmission in each of the driving gears while attempting to start the engine. The starter should operate only in the Park ("P") or Neutral ("N") positions.

d. **STARTER SAFETY SWITCH (MANUAL TRANSMISSION)** — To check, place the shift lever in neutral, depress the clutch halfway, and attempt to start. The starter should operate only when clutch is fully depressed.

e. **TRANSMISSION SHIFT INDICATOR**—Check to be sure automatic transmission shift indicator accurately indicates the shift position selected.

f. **STEERING**—Be alert to any changes in steering action. The need for inspection or servicing may be indicated by "hard" steering, excessive free play or unusual sounds when turning or parking.

g. **WHEEL ALIGNMENT AND BALANCE**—In addition to abnormal tire wear, the need for wheel alignment service may be indicated by a pull to the right or left when driving on a straight and level road. The need for wheel balancing is usually indicated by a vibration of the steering

wheel or seat while driving at normal highway speeds.

h. **BRAKES**—Be alert to illumination of the brake warning light or changes in braking action, such as repeated pulling to one side, unusual sounds when braking or increased brake pedal travel. Any of these could indicate the need for brake system inspection and/or service.

i. **EXHAUST SYSTEM**—Be alert to any change in the sound of the exhaust system or a smell of fumes which may indicate a leak.

j. **WINDSHIELD WIPERS AND WASHERS**—Check operation of wipers, as well as condition and alignment of wiper blades. Check amount and direction of fluid sprayed by washers during use.

k. **DEFROSTERS**—Check performance by moving controls to "DEF" and noting amount of air directed against the windshield.

l. **REARVIEW MIRRORS AND SUN VISORS**—Check that friction joints are properly adjusted so mirrors and sun visors stay in the selected position.

m. **HORN**—Blow the horn occasionally to be sure that it works.

n. **LAP AND SHOULDER BELTS**—Check belts, buckles, retractors, and anchors for cuts, fraying or weakened portions, loose connections, damage, and for proper operation. Check to make certain that anchor mounting bolts are tight.

o. **HEAD RESTRAINTS**—Check that head restraints, if present, adjust properly in the up detent positions, and that no components are missing, damaged or loose.

p. **SEAT BACK LATCHES (if so equipped)**—Check to see that seat back latches are holding by pulling forward on the top of each folding seat back.

q. **LIGHTS AND BUZZERS**—Check all instrument panel illuminating and warning lights, interior lights, license plate lights, side marker lights, headlamps, parking lamps, tail lamps, brake lights, turn signals, backup lamps, and hazard warning flashers. Have someone observe operation of each exterior light while you activate the controls.

r. **GLASS**—Check for broken, scratched, dirty or damaged glass on vehicle that could obscure vision or become an injury hazard.

s. **DOOR LATCHES** — Check for positive closing, latching and locking.

t. **HOOD LATCHES**—Check to make sure hood closes firmly by lifting on the hood after each closing. Check also for broken, damaged or missing parts which might prevent secure latching.

\*Also a safety Service

\*\*Also an Emission Control Service

- u. **FLUID LEAKS**—Check for fuel, water, oil or other fluid leaks by observing the ground beneath the vehicle after it has been parked for a while. (Water dripping from air conditioning system after use is normal.) If gasoline fumes or fluid are noticed at any time, the cause should be determined and corrected without delay because of the possibility of fire.
  - 13. **TIRES AND WHEELS**—Check tires for excessive wear, nails, glass, cuts or other damage. Make certain wheels are not bent or cracked and wheel nuts are tight. Uneven or abnormal tire wear may indicate the need for alignment service. Tire inflation pressure should be checked by the owner at least monthly, or more often if daily visual inspection indicates the need. Refer to Section 10 in this manual for information on tire tread wear indicators.
  - 14. **EXHAUST SYSTEM**—Check complete exhaust system and nearby body areas for broken, damaged, missing or mispositioned parts, open seams, holes, loose connections or other deterioration which could permit exhaust fumes to seep into the passenger compartment. Dust or water in the passenger compartment may be an indication of a problem in one of these areas. Any defects should be corrected immediately. To help insure continued integrity, exhaust system pipes and resonators rearward of the muffler must be replaced whenever a new muffler is installed.
  - 15. **ENGINE DRIVE BELTS\*\***—Check belts driving fan, AIR pump, Delcotron, power steering pump and air conditioning compressor for cracks, fraying, wear and tension.\*\* Adjust or replace as necessary.
- It is recommended that belts be replaced every 24 months or 24,000 miles, whichever occurs first.
- 16. **SUSPENSION AND STEERING**—Check for damaged, loose or missing parts, or parts showing visible signs of excessive wear or lack of lubrication in front and rear suspension and steering system. Questionable parts noted should be replaced without delay.
  - 17. **BRAKES AND POWER STEERING**—Check lines and hoses for proper attachment, leaks, cracks, chafing, deterioration, etc. Any questionable parts noted should be replaced or repaired immediately. When abrasion or wear is evident on lines or hoses, the cause must be corrected.
  - 18. **DISC BRAKES**—Be alert for disc brake wear indicator sound (see Section 5 in this manual for descriptive details). Check brake pads and condition of rotors while wheels are removed during tire rotation. (Note below regarding more frequent checks also applies to disc brakes.)
  - 19. **DRUM BRAKES AND PARKING BRAKE**—Check drum brake linings and other internal brake components at each wheel (drums, wheel cylinders,

etc.). Parking brake adjustment also should be checked for drag and lubricated at every chassis lube period.

NOTE: More frequent checks should be made if driving conditions and habits result in frequent brake application.

- 20. **THROTTLE LINKAGE**—Check for damaged or missing parts, interference or binding. Any deficiencies should be corrected without delay.
- 21. **HEADLIGHTS**—Check for proper aim. Correct as necessary. More frequent checks should be made if oncoming motorists signal when lights are already on low beam, or if illumination of the area ahead seems inadequate.
- 22. **UNDERBODY**—In geographic areas using a heavy concentration of road salt or other corrosive materials for snow removal or road dust control, flush and inspect the complete under side of the car at least once each year, preferably after a winter's exposure. Particular attention should be given to cleaning out underbody members where dirt and other foreign materials may have collected.

### EMISSION CONTROL MAINTENANCE

- 23. **THERMOSTATICALLY CONTROLLED AIR CLEANER**—Inspect installation to make certain that all hoses and ducts are connected and correctly installed. Also check valve for proper operation.
- 24. **CARBURETOR CHOKE**—Check choke mechanism for free operation. Any binding condition which may have developed due to petroleum gum formation on the choke shaft or from damage should be corrected.
- 25. **TIMING, DWELL, CARBURETOR IDLE, DISTRIBUTOR AND COIL**—Adjust ignition timing, dwell and carburetor idle speed accurately (following the specifications shown on the label under the hood) at the first 4 months or 6,000 miles of operation then at 12-month or 12,000-mile intervals. Adjustments must be made with test equipment known to be accurate.

Replace distributor points every 12 months or 12,000 miles and replace cam lubricator every 24 months or 24,000 miles. In addition, carefully inspect the interior and exterior of the distributor cap, distributor rotor and coil for cracks, carbon tracking, and terminal corrosion. Clean or replace as necessary at 12-month/12,000-mile intervals to prevent misfiring and/or deterioration.

Proper functioning of the carburetor is particularly essential to control of emissions. Correct mixtures for emission compliance and idle quality have been preset by Chevrolet. Plastic idle mixture limiters have been installed on the idle mixture screws to preclude unauthorized adjustment. These idle limiters are not to be removed unless some major carburetor repair or replacement which affects the idle screw adjustment, has been necessary.

\*Also a safety Service

\*\*Also an Emission Control Service

At 24 month or 24,000 mile intervals on all 10 Series vehicles, and on 20 Series Suburban, Chevy Van and Sportvan, and 30 Series Sportvan vehicles (12 month or 12,000 mile intervals on all other 20 and 30 Series vehicles) or in case of a major carburetor overhaul, or when poor idle quality exists, idle mixture should be adjusted by a mechanical method (lean drop). The alternate method for adjusting idle mixture is by CO meter if accurate meter is available.

26. **MANIFOLD HEAT VALVE**—Some engines are equipped with a manifold heat valve which should be inspected and repaired as necessary to insure free operation.
27. **CARBURETOR MOUNTING**—Torque carburetor attaching bolts and/or nuts to compensate for compression of gasket at first 4 months or 6,000 miles of vehicle operation, then at every 12,000 miles thereafter.
28. **SPARK PLUGS**—Replace at 6,000-mile intervals when operating with leaded fuels or at 12,000-mile intervals when using unleaded fuels. Use of leaded fuels results in lead deposits on spark plugs and can cause misfiring at mileages less than 12,000 miles. Where misfiring occurs prior to 6,000 miles, spark plugs in good condition can often be cleaned, tested and reinstalled in an engine with acceptable results.
29. **EXHAUST GAS RECIRCULATION SYSTEM (EGR)**—At 12-month/12,000 mile intervals when operating with leaded fuels or at 24-month/24,000 mile intervals when using unleaded fuels remove, inspect, and if deposits exist, clean the EGR valve. Inspect the EGR passages in the inlet manifold and clean as required. A damaged EGR valve must be repaired or replaced.
30. **CARBURETOR FUEL INLET FILTER**—Replace filter at 12-month/12,000-mile intervals or more frequently if clogged.
31. **THERMAL VACUUM SWITCH AND HOSES**—Check for proper operation. A malfunctioning switch must be replaced. Check hoses for proper connection, cracking, abrasion or deterioration and replace as necessary.
32. **VACUUM ADVANCE SOLENOID AND HOSES**—Check both the vacuum and electrical functions of this valve. An inoperative or leaking valve should be replaced. Check condition of wires and connections. Check hoses for proper connection, cracking, abrasion or deterioration and replace as necessary.
33. **TRANSMISSION CONTROL SWITCH**—Check the electrical function of this switch. An inoperative switch should be replaced. Check condition of wires and connections.
34. **IDLE STOP SOLENOID**—Check for proper operation. An inoperative solenoid must be replaced.
35. **POSITIVE CRANKCASE VENTILATION SYSTEM (PCV)**—Check the PCV system for satisfactory operation at 12-month or 12,000-mile intervals

using a tester. Replace the PCV valve at 24-month or 24,000 mile intervals, blow out PCV valve hose with compressed air and replace the filter. The PCV valve should be replaced at 12-month or 12,000 mile intervals when the vehicle is used in operations involving heavy dust, extensive idling, trailer pulling, and short trip use at freezing temperatures where engine does not become thoroughly warmed-up.

The PCV filter should be replaced at 12-month/12,000-mile intervals under dusty driving conditions.

36. **ENGINE COMPRESSION**—Test engine cranking compression. If a problem exists, have correction made. Minimum compression recorded in any one cylinder should not be less than 70% of highest cylinder. For example, if the highest pressure in any one cylinder is 150 pounds, the lowest allowable pressure for any other cylinder would be 105 pounds ( $150 \times 70\% = 105$ ).
37. **EVAPORATION CONTROL SYSTEM (ECS)**—Check all fuel and vapor lines and hoses for proper connections and correct routing as well as condition. Remove canister and check for cracks or damage. Replace damaged or deteriorated parts as necessary. Replace filter in lower section of canister.
38. **FUEL CAP, FUEL LINES AND FUEL TANK**—Inspect the fuel tank, cap and lines for damage which could cause leakage. Inspect fuel cap for correct sealing ability and indications of physical damage. Replace any damaged or malfunctioning parts.
39. **AIR INJECTION REACTOR (AIR) SYSTEM HOSES AND CONNECTIONS**—Check AIR system hoses and fittings for loose connections and deterioration. Test diverter valve for proper operation. Malfunctioning diverter valves and deteriorated hoses must be replaced.
40. **AIR CLEANER ELEMENT**—Replace the engine air cleaner element under normal operating conditions every 12,000 miles (24,000 miles in V-8 engine equipped 10 Series vehicle, 20 Series Suburban, Chevy Van and Sportvan vehicles, and 30 Series Sportvan vehicles). Operation of vehicle in dusty areas will necessitate more frequent element replacement.
 

**CAUTION:** Do not operate the engine without the air cleaner unless temporary removal is necessary during repair or maintenance of the vehicle. When the air cleaner is removed, backfiring can cause fire in the engine compartment.
41. **SPARK PLUG AND IGNITION COIL WIRES**—Inspect spark plug and ignition coil wires for evidence of checking, burning, or cracking of exterior insulation and tight fit at distributor cap, coil, and spark plugs. Exterior of wires should be cleaned; any evidence of corrosion on end terminals removed and wires replaced as necessary to prevent misfiring and/or deterioration.

\*Also a safety Service

\*\*Also an Emission Control Service

RECOMMENDED FLUIDS & LUBRICANTS

USAGE	FLUID/LUBRICANT
Power steering system and pump reservoir	GM power steering fluid Part No. 1050017 or equivalent—if not available use DEXRON® or DEXRON® II automatic transmission fluid
Differential—standard	SAE-80 or SAE-90 GL-5 gear lubricant (SAE-80 in Canada)
Differential—Positraction	Lubricant GM Part No. 1051022 or equivalent
Manual steering gear	Lubricant GM Part No. 1051052 or equivalent
Manual transmission	SAE-80 or SAE-90 GL-5 gear lubricant (SAE-80 in Canada)
Brake system and master cylinder	Delco Supreme 11 fluid or DOT-3
Clutch linkage (Man. trans. only)	
a. Pivot points	Engine oil
b. Push rod to clutch fork joint, and cross shaft pressure fitting	Chassis grease meeting requirements of GM 6031-M
Manual transmission shift linkage, column shift	Engine oil
Shift linkage, floor shift	Engine oil
Hood Latch assembly	
a. Pivots and spring anchor	Engine oil
b. Release pawl	Chassis grease

USAGE	FLUID/LUBRICANT
Hood hinges	Engine oil
Automatic transmission shift linkage	Engine oil
Chassis lubrication	Chassis grease meeting requirements of GM 6031-M
Constant Velocity Universal Joint	GM Lubricant Part No. 1050679 or grease meeting requirements of GM 6040-M
Automatic transmission	DEXRON® or DEXRON® II automatic transmission fluid
Parking brake cables	Chassis grease
Front wheel bearings	Chassis grease meeting requirements of GM 6031-M
Body door hinge pins, station wagon tailgate hinge and linkage, station wagon folding seat, fuel door hinge, rear compartment lid hinges	Engine oil
Convertible door to lock wedge plates	Stick-type lubricant
Windshield washer solvent	GM Optikleen washer solvent Part No. 1050001 or equivalent
Engizger (Battery)	Colorless, odorless, drinking water
Engine coolant	Mixture of water and a high quality Ethylene Glycol base type anti-freeze conforming to GM Spec. 1899-M

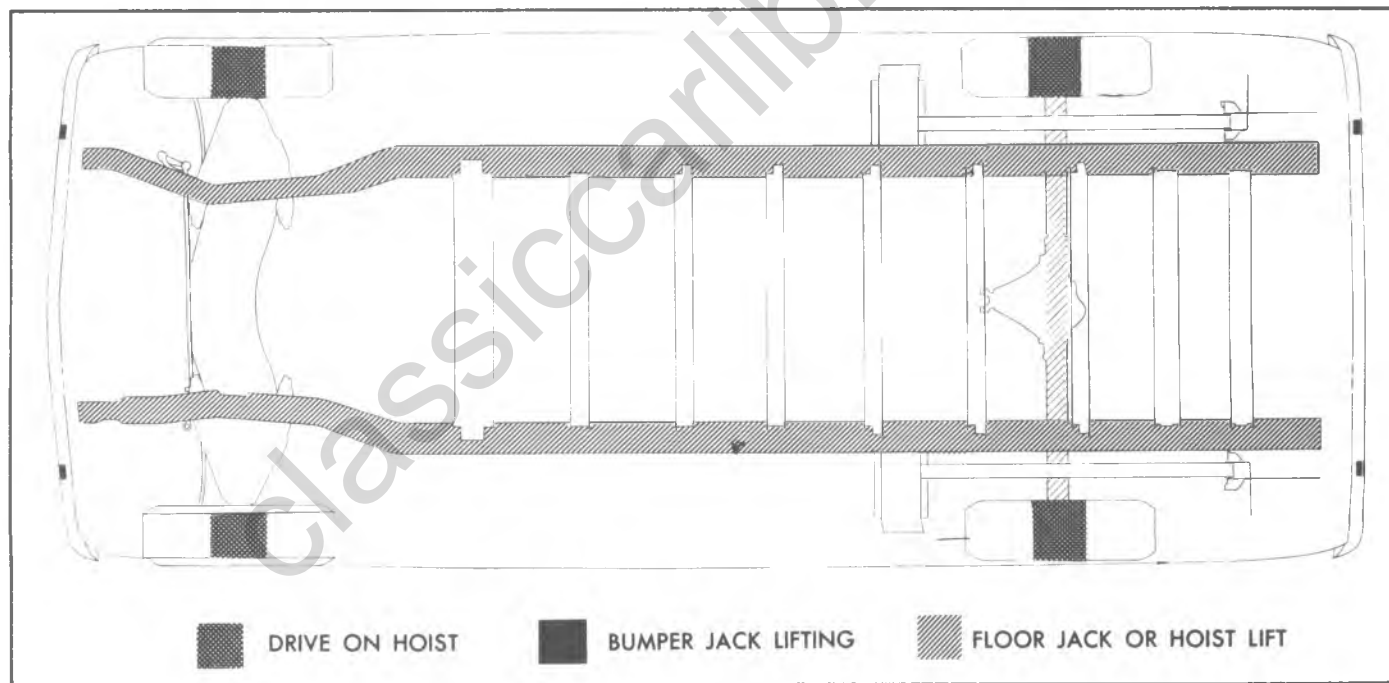
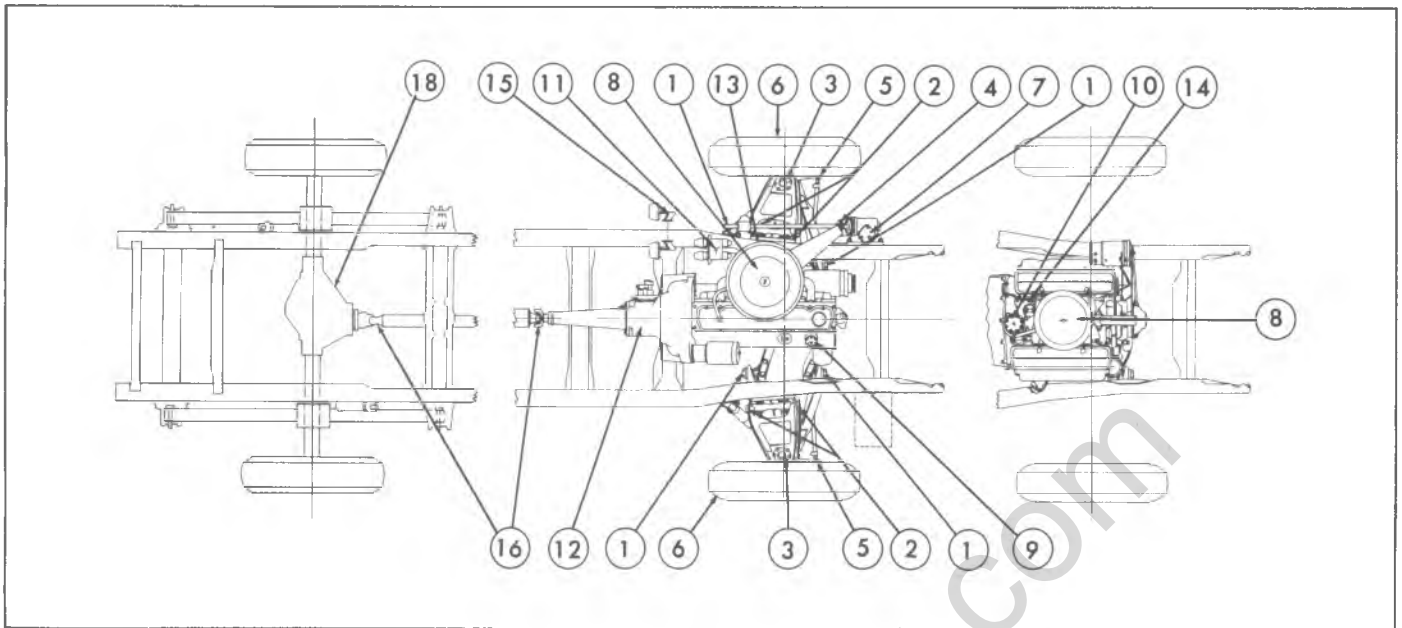

Fig. 7—G Model Lifting Points



No.	Lubrication Points	Lubrication Period	Type of Lubrication	Quantity	Remarks
1	Lower Control Arms	6,000 Miles	Chassis Lubricant	4 places as required	
2	Upper Control Arms	6,000 Miles	Chassis Lubricant	4 places as required	
3	Upper and Lower Control Arm Ball Joints	6,000 Miles	Chassis Lubricant	4 places as required	
4	Intermediate Steering Shaft (PA10)	6,000 Miles	Chassis Lubricant	2 places as required	
5	Tie Rod Ends	6,000 Miles	Chassis Lubricant	4 places as required	
6	Wheel Bearings	24,000 Miles	Whl. Brq. Lubricant	2 places as required	
7	Steering Gear	36,000 Miles			
8	Air Cleaner – Element	12,000 Miles			Check for Grease Leak— Do not Lubricate See Vehicle Maintenance Schedule
9	Distributor – L-6	24,000 Miles			Replace cam lubricator*
10	Distributor – V-8	24,000 Miles			Replace cam lubricator*
11	Master Cylinder	6,000 Miles	Delco Supreme No. 11 or DOT-3 fluids	As required	Check – add fluid when necessary
12	Transmission – Manual	6,000 Miles	GL-5	As required	Keep even w/filler plug.
	– Automatic	6,000 Miles	Dexron® or equivalent	As required	See Lubrication Section
13	Throttle Bell Crank – L-6	12,000 Miles	Engine Oil	As required	
14	Carburetor Linkage – V-8	12,000 Miles	Engine Oil	As required	
15	Brake and Clutch Pedal Springs	6,000 Miles	Engine Oil	As required	
16	Universal Joints	6,000 Miles	Chassis Lubricant	As required	
17	Propeller Shaft Slip Joint	6,000 Miles	Chassis Lubricant	As required	Not shown
18	Rear Axle	6,000 Miles	GL-5	As required	Check See Lubrication section

\*Replace Points at 12,000 mile intervals.

Fig. 8—Lubrication - Conventional Models

0-18 GENERAL INFORMATION AND LUBRICATION

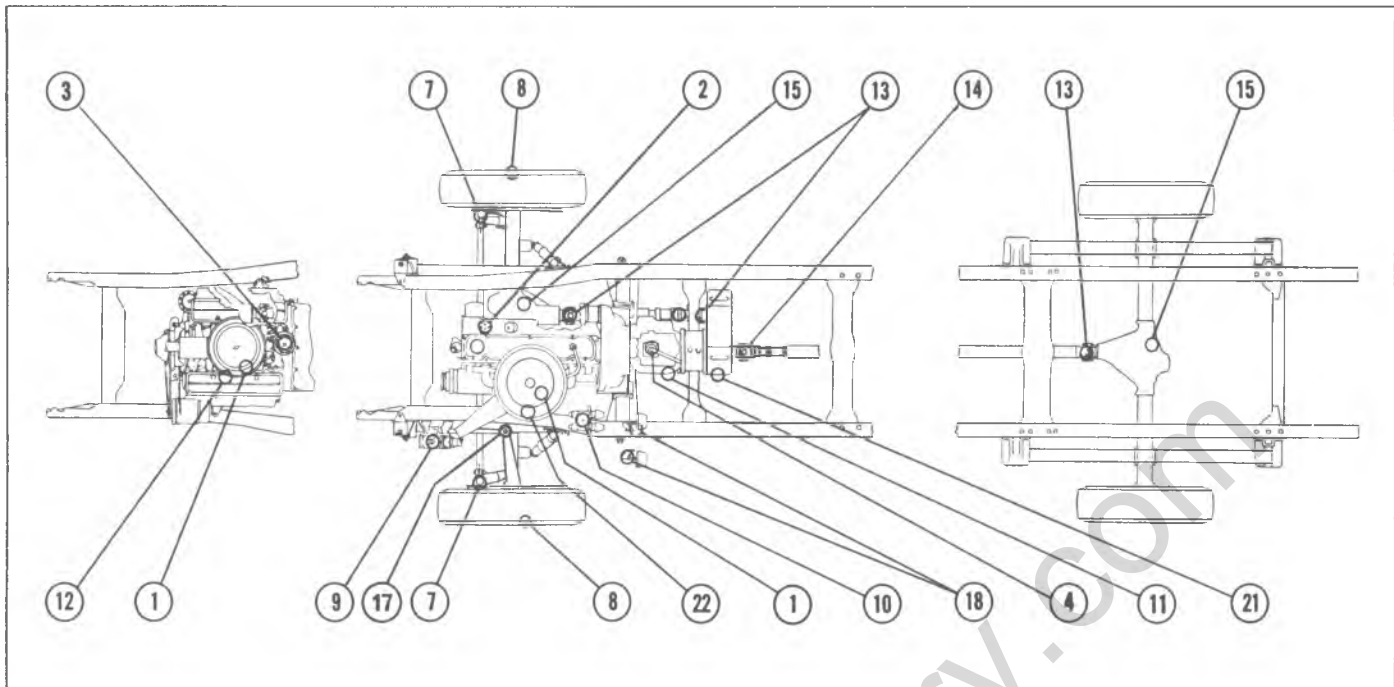

No.	Lubrication Points	Lubrication Period	Type of Lubrication	Quantity	Remarks
1	Air Cleaner	12,000 Miles			See Vehicle Maintenance Schedule
2	Distributor – L-6	24,000 Miles			Replace Cam Lubricator*
3	Distributor – V-8	24,000 Miles			Replace Cam Lubricator*
4	Control Linkage Points	12,000 Miles	Engine Oil	As required	Brush or Spray to apply
7	Tie Rod Ends	6,000 Miles	Chassis Lubricant	2 places as required	
8	Wheel Bearings	24,000 Miles	Wheel Bearing Grease	2 places as required	
9	Steering Gear	36,000 Miles			Check for Grease Leak Do not Lubricate
10	Master Cylinder	6,000 Miles	Delco Supreme No.11 or DOT-3 fluids	As required	Check – add fluid when necessary
11	Transmission – Manual – Automatic	6,000 Miles 6,000 Miles	GL-5 Dexron® or equivalent	As required As required	Keep even w/filler plug See Lubrication Section
12	Carburetor Linkage – V-8	12,000 Miles	Engine Oil	As required	
13	Universal Joints	6,000 Miles	Chassis Lubricant	As required	See Lubrication Section
14	Propeller Shaft Slip Joints	6,000 Miles	Chassis Lubricant	3 places as required	
15	Front and Rear Axle	6,000 Miles	GL-6	As required	Check See Lubrication Section
17	Drag Link	6,000 Miles	Chassis B	2 places as required	
18	Brake and Clutch Pedal Springs	6,000 Miles	Engine Oil	As required	
21	Transfer Case	6,000 Miles	GL-5	As required	Check See Lubrication Section
22	Throttle Bell Crank – L-6	12,000 Miles	Engine Oil	As required	

\*Replace Points at 12,000 mile intervals.

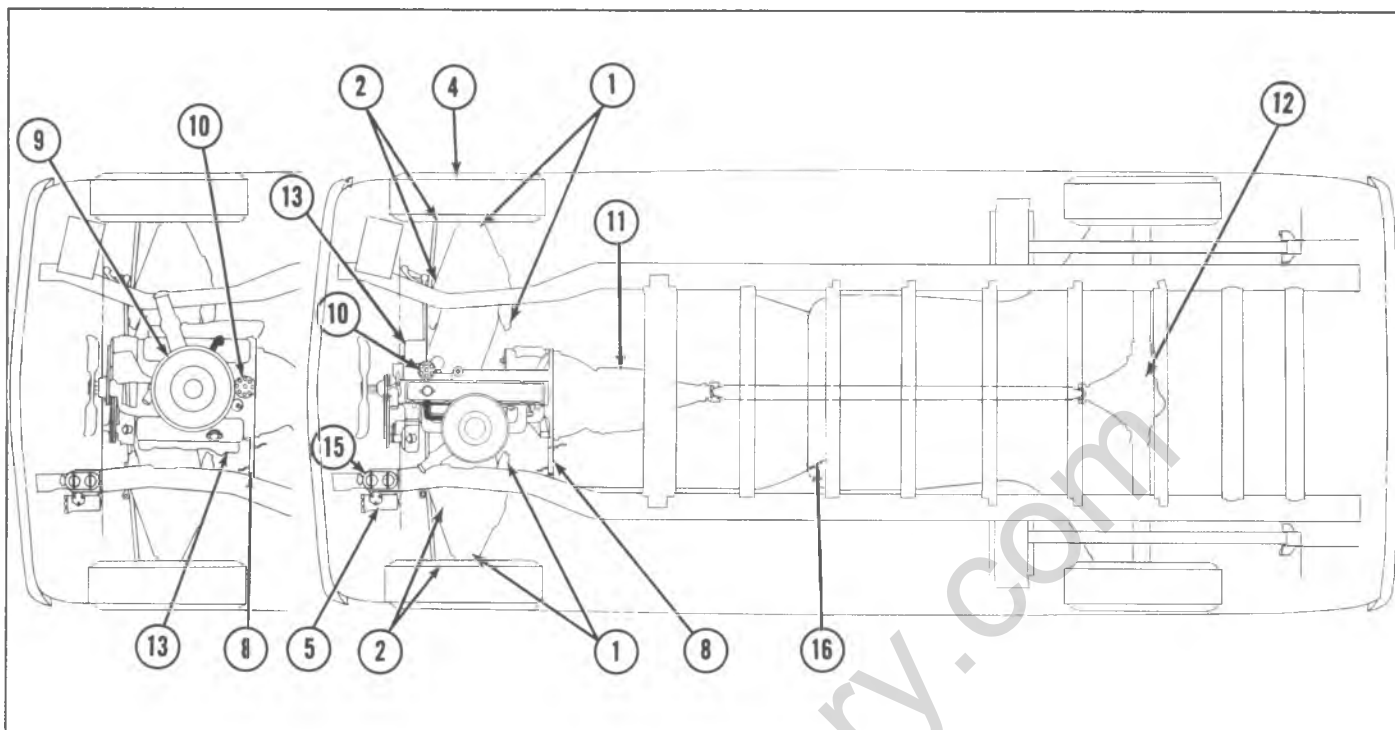

No.	Lubrication Points	Lubrication Period	Type of Lubrication	Quantity	Remarks
1	Control Arm Bushings and Ball Joints	6,000 Miles	Chassis Lubricant	12 places as required	
2	Tie Rod Ends	6,000 Miles	Chassis Lubricant	4 places as required	2 fittings each side
4	Wheel Bearings	24,000 Miles	Whl. Brg. Lubricant	2 places as required	
5	Steering Gear	36,000 Miles			
	Clutch Cross-Shaft	6,000 Miles	Chassis Lubricant	As required	
8	Trans. Control Shaft	6,000 Miles	Chassis Lubricant	As required	
9	Air Cleaner—Element	12,000 Miles			See Vehicle Maintenance Schedule
10	Distributor—L-6, V-8	24,000 Miles			Replace Cam Lubricator*
11	Transmission—Synchromesh—Automatic	6,000 Miles 6,000 Miles	GL-5 Dexron® or Equivalent	As required As required	See Lubrication Section See Lubrication Section
12	Rear Axle	6,000 Miles	GL-5	As required	See Lubrication Section
13	Oil Filter	Every Second Oil Change			
15	Brake Master Cylinder	6,000 Miles	Delco Supreme No. 11 or DOT-3 fluids	As required	Check—Add fluid when necessary
16	Parking Brake Linkage	6,000 Miles	Chassis Lubricant		Lubricate Linkage and Cables

\* Replace Points at 12,000 Mile Intervals.

Fig. 10—Lubrication-1/2, 3/4 and 1 Ton G Models

classicalibrary.com



## SECTION 1A

## HEATER AND AIR CONDITIONING

## CONTENTS OF THIS SECTION

Standard Heater .....	1A-1
Auxiliary Heater.....	1A-15
Air Conditioning.....	1A-19

## STANDARD HEATER

## INDEX

General Description .....	1A-1	Center Distributor Duct - G Models.....	1A-6
Theory of Operation.....	1A-4	Left Distributor Duct - G Models.....	1A-7
System Components.....	1A-4	Defroster Duct.....	1A-7
System Controls.....	1A-4	Control Assembly.....	1A-8
Component Replacement and Repair .....	1A-5	Control Cables.....	1A-8
Blower Motor.....	1A-5	Blower Switch.....	1A-10
Heater Distributor and Core Assembly.....	1A-5	Resistor Unit.....	1A-10
Heater Hoses.....	1A-6	Diagnosis.....	1A-11

## GENERAL DESCRIPTION

Heating components are attached to the dash panel on the right side of the vehicle. The blower and air inlet assembly and water hoses are located on the forward side of the dash panel while the heater core and distributor duct are on the passenger side.

The heater system is an air mix type system in which outside air is heated and then mixed in varying amounts with cooler outside air to attain the desired air temperature. The system consists basically of three parts: (1) the blower and air inlet assembly, (2) the heater distributor assembly and (3) the heater control assembly.

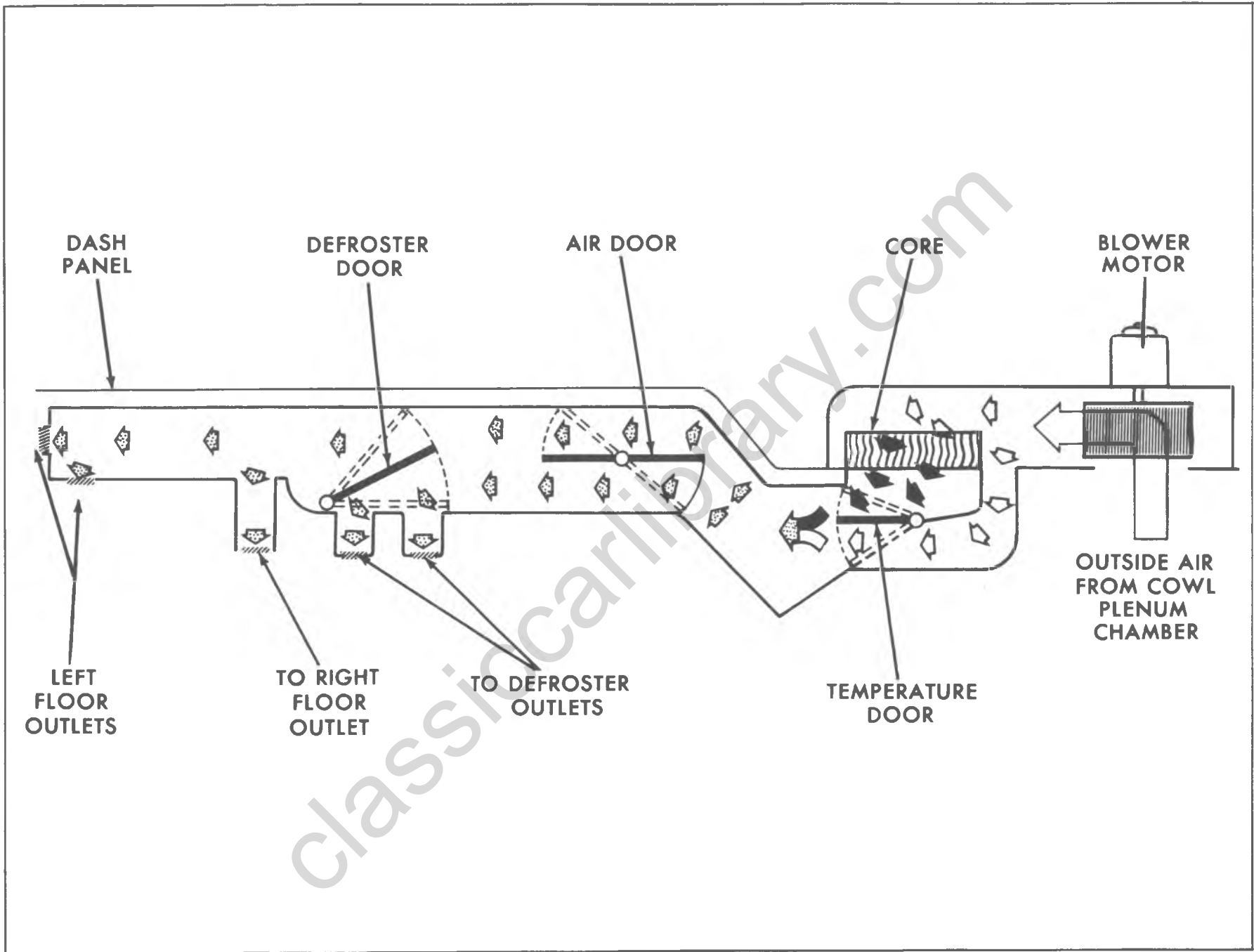

Fig. 1A-Heater Air Flow Schematic-G Models

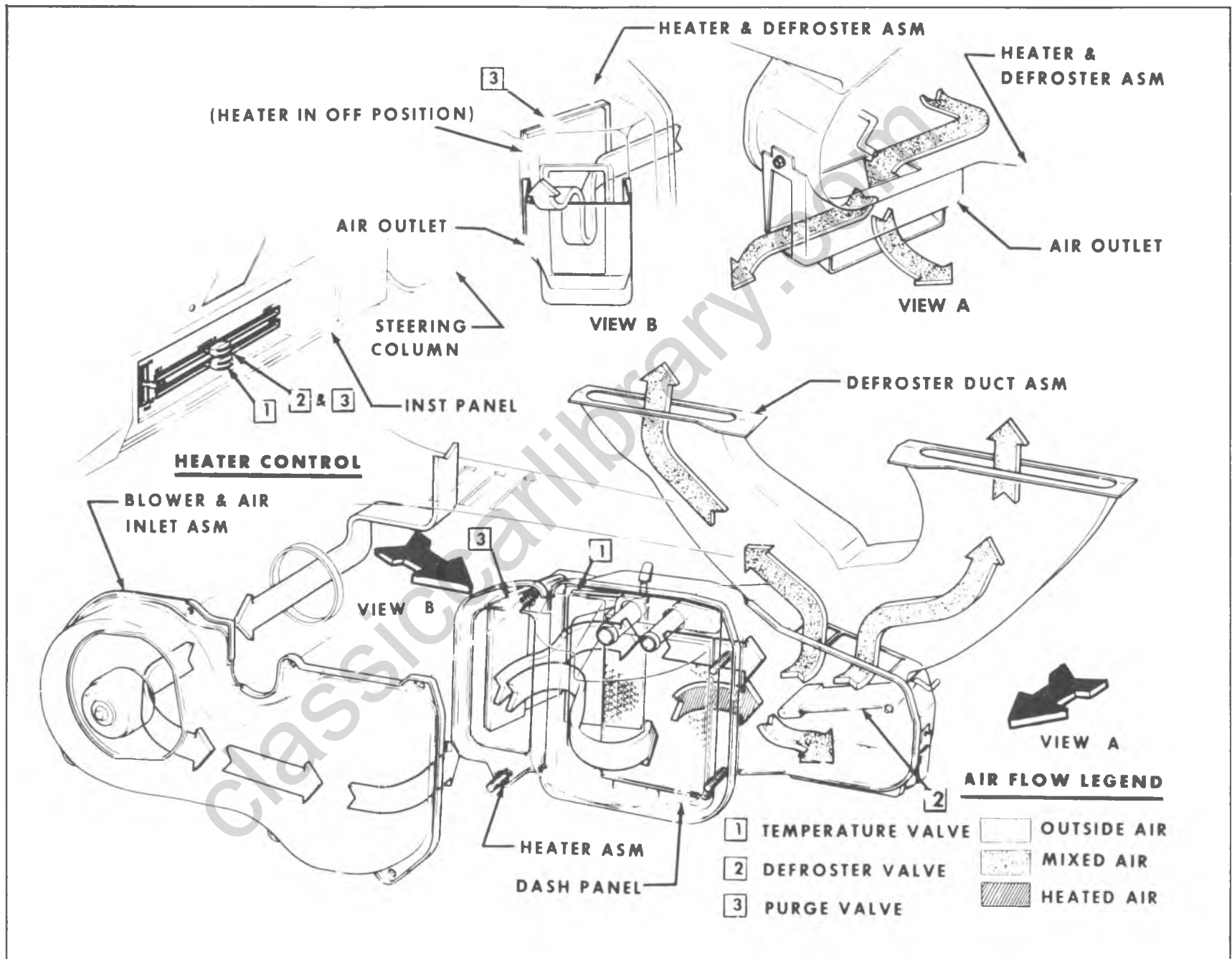

Fig. 1B-Heater Air Flow Schematic-C-K Models

## THEORY OF OPERATION

### BLOWER AND AIR INLET ASSEMBLY

The blower and air inlet assembly draws outside air through the outside air inlet grille located forward of the windshield reveal molding and channels the air into the heater distributor assembly. The operation of the blower motor is controlled by the FAN switch on the heater control. The motor is connected in series with the FAN switch and also the blower resistor assembly. Located in the fuse block, in series between the blower motor and the battery, is a 25 amp. fuse C-K models - a 20 amp fuse on G models.

### HEATER DISTRIBUTOR ASSEMBLY

The heater distributor assembly houses the heater core and the doors necessary to control mixing and channeling of the air. Since the unit has no water valve, water circulation keeps the core hot at all times. That portion of the air passing through the core receives maximum heat from the core. Air entering the distributor assembly is channeled as follows:

#### C-K Models

Air entering the distributor can be directed out the purge door opening, on the right end of the distributor assembly, by the purge door. If the purge door is closed, then air is directed through and/or around the heater core by the temperature door. Air is then directed into the passenger compartment through the heater (floor) outlets and/or the defroster (dash) outlets by the defroster door. The temperature of the outlet air is dependent on the ratio of heated to unheated air (controlled by the temperature door).

#### G Models

Airflow is controlled by three doors in the distributor assembly. The air door can be adjusted to vary airflow. If air is allowed to enter the distributor assembly, it is then directed through and/or around the heater core by the temperature door. Air is directed into the passenger compartment through the heater (floor) and/or defroster (dash) outlets by the defroster door. The temperature of the outlet air is dependent on the ratio of heated to unheated air (controlled by the temperature door).

### CONTROLS

#### C-K Models (Fig. 2)

These controls are mounted in the center of the dash, above the radio assembly. The control incorporates two levers which make use of bowden cables to control positioning of the purge, temperature and defroster doors.

#### Temperature Lever

This lever controls the positioning of the TEMPERA-

TURE door in the heater distributor assembly. All incoming "outside" air is directed around the heater core in the COLD position or through the core in the HOT position. The desired outlet temperature is obtained by blending the heated and unheated air according to the setting of the temperature lever.

#### Heater-Def Lever

The HEATER-DEF lever controls the position of the DEFROSTER door and the PURGE door. In the OFF position, the blower is "on" and incoming air is directed up under the dash through the purge door opening. As the lever is moved to the right of the OFF position, the door closes, directing airflow on into the distributor assembly. With the lever at HEATER, the DEFROSTER door directs almost all airflow to the heater (floor) outlets - a small amount of air is directed to the defroster (dash) outlets. In the DEF position, most airflow is diverted to the defroster outlets. Moving the lever part way, as desired, will split airflow between the floor and defroster outlets.

#### Fan Control

The blower fan lever is located at the left hand side of the control assembly. The blower motor will operate as soon as the ignition switch is turned to the RUN position. The control has three positions only; LO, MED, HI. There is no OFF position.

#### G Models (Fig. 3)

The controls are located in the instrument panel, just to the right of the instrument cluster. In operation, two levers control all heating operations.



Fig. 2--Heater Control--C-K Models

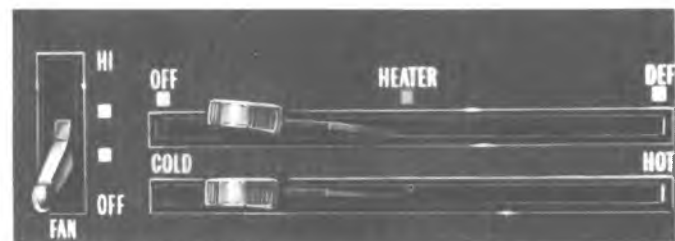

Fig. 3--Heater Control--G Models

### Temperature Lever

This lever controls the positioning of the TEMPERATURE door in the heater distributor assembly. All incoming "outside" air is directed around the heater core in the COLD position on through the core in the HOT position. The desired outlet temperature is obtained by blending heated and unheated air according to the setting of the temperature lever.

### Heater-Def Lever

The HEATER-DEF lever controls positioning of the AIR and DEFROSTER doors in the heater distributor assembly. In the OFF position, no air is allowed to enter

the system. Moving the lever to the right (toward HEATER) opens the air door with the AIR door being fully open at the HEATER position. Incoming air is directed to the heater outlets (with slight air bleed to the defroster outlets). Moving the lever between HEATER and DEF, directs increasing amounts of air to the defroster outlets until all air is directed to the defroster outlets in the DEF position.

### Fan Control

The blower fan lever is located on the left hand side of the control assembly. When the lever is fully down, the blower motor is inoperative. Moving the lever upward actuates the three speed blower motor (LOW-MED-HI).

## COMPONENT PART REPLACEMENT

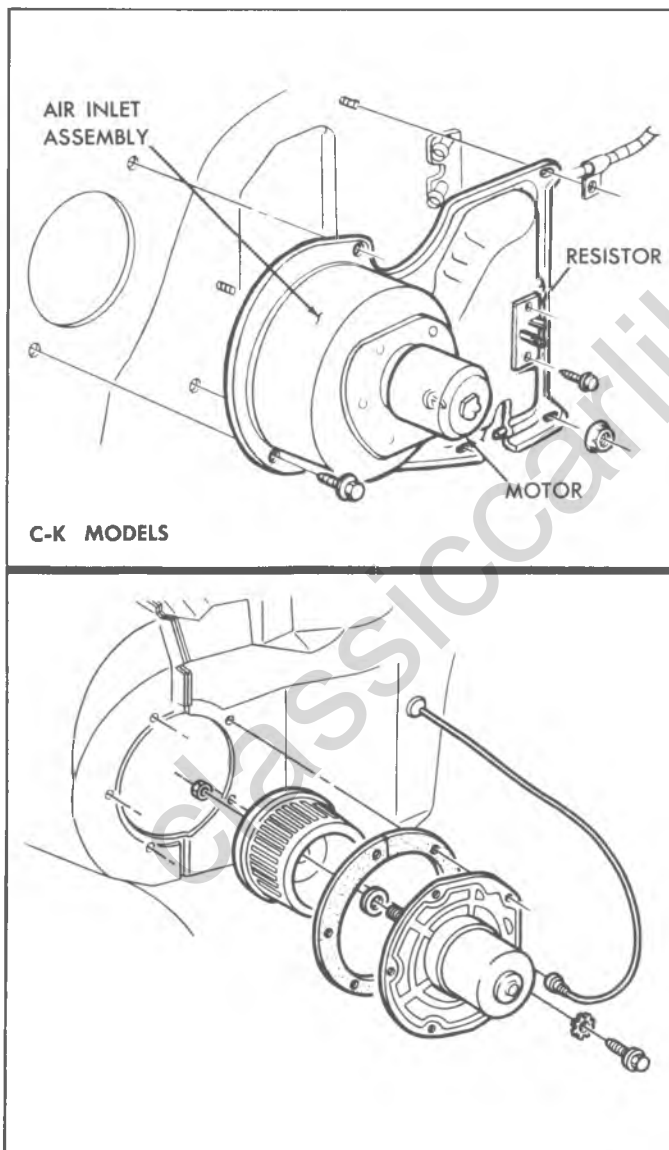

Fig. 4-Blower Motor Assembly

### BLOWER MOTOR

#### Removal (Fig. 4)

1. Disconnect battery ground cable.
- G Models** - Remove the battery.
2. Disconnect the blower motor lead wire.
3. Remove the five blower motor mounting screws and remove the motor and wheel assembly. Pry gently on the blower flange if the sealer acts as an adhesive.
4. Remove the blower wheel to motor shaft nut and separate the wheel and motor assemblies.
5. To install a new motor, reverse Steps 1-4 above.

NOTE: The following precautions should be taken to assure proper installation:

- a. Assemble the blower wheel to the motor with the open end of the wheel away from the blower motor.
- b. If the motor mounting flange sealer has hardened, or is not intact, remove the old sealer and apply a new bead of sealer to the entire circumference of the mounting flange.
- c. Check blower operation; blower wheel should rotate freely with no interference.

### HEATER DISTRIBUTOR AND CORE ASSEMBLY

#### C-K Models

#### Replacement (Fig. 5)

1. Disconnect the battery ground cable.
2. Disconnect the heater hoses at the core tubes and drain engine coolant into a clean pan. Plug the core tubes to prevent coolant spillage at removal.

## 1A-6 HEATER AND AIR CONDITIONING

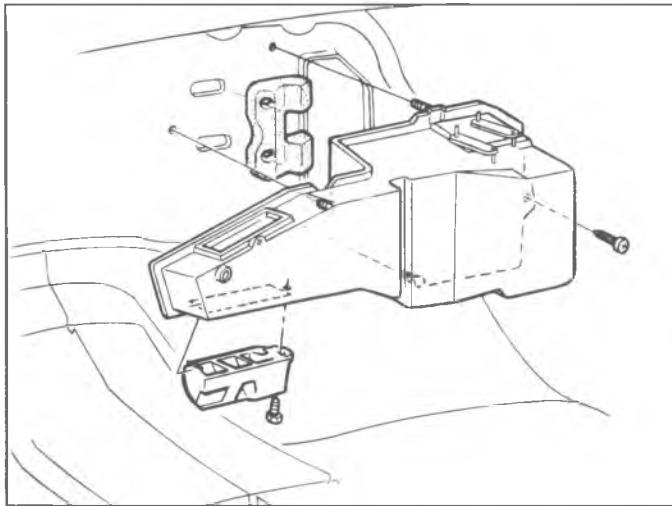

Fig. 5-Heater Distributor Assembly--C-K Models

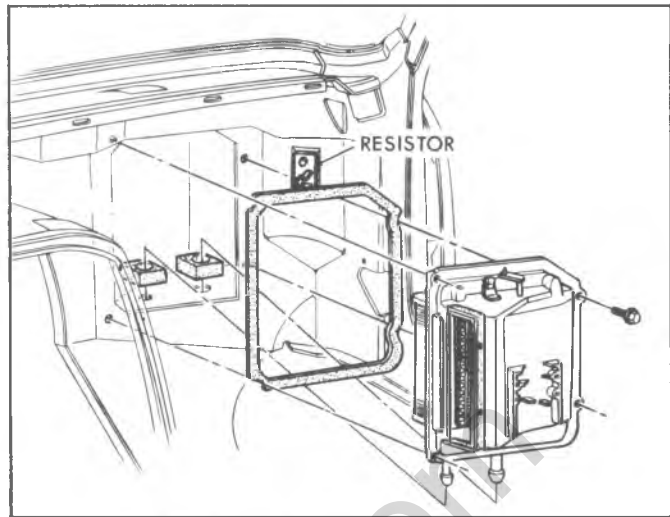

Fig. 6-Heater Distributor - G Models

3. Remove the nuts from the distributor duct studs projecting into the engine compartment.
4. Remove the glove box and door assembly.
5. Disconnect the Air-Defrost and Temperature door cables.
6. Remove the floor outlet and remove the defroster duct to heater distributor duct screw.
7. Remove the heater distributor to dash panel screws. Pull the assembly rearward to gain access to wiring harness and disconnect all harness attached to the unit.
8. Remove the heater-distributor from the vehicle.
9. Remove the core retaining straps and remove the core.
10. To install, reverse Steps 1-9 above.

NOTE: Be sure core to case and case to dash panel sealer is intact before assembling unit.

### G Models

#### Replacement (Fig. 6)

1. Disconnect the battery ground cable.
2. Place a clean pan under the vehicle and then disconnect the heater core inlet and outlet hoses at the core connections (see "Heater Hoses-Replacement" later in this section). Quickly plug the heater hoses and support them in a raised position. Allow the coolant in the heater core to drain into the pan on the floor.
3. Disconnect the right hand air distributor hose from the heater case and rotate it up out of the way.
4. Pry off the temperature door cable eyelet clip and then remove the bowden cable attaching screw.
5. Remove the distributor duct to heater case screws

and pull the duct rearward out of the heater case retainer.

6. Remove the four heater case to dash screws and then remove the heater case and core as an assembly. Tilt the case assembly rearward at the top while lifting up until the core tubes clear the dash openings.
7. Remove the core retaining strap screws and remove the core.
8. To install a new core, reverse Steps 1-7 above.

NOTE: Be sure core to case and case to dash panel sealer is intact before assembling unit.

### HEATER HOSES

Heater hoses are routed from the thermostat housing or inlet manifold and water pump (radiator on some automatic transmission vehicles) to the core inlet and outlet pipes as shown in Figure 7. Hoses are attached at each end with screw type clamps.

#### Replacement

The heater core can be easily damaged in the area of the core tube attachment seams whenever undue force is exerted on them. Whenever the heater core hoses do not readily come off the tubes, the hoses should be cut just forward of the core tubes. The portion of the hose remaining on the core tube should then be split longitudinally. Once the hoses have been split, they can be removed from the tubes without damage to the core.

### CENTER DISTRIBUTOR DUCT - G Models

#### Replacement (Fig. 8)

1. Disconnect the battery ground cable.

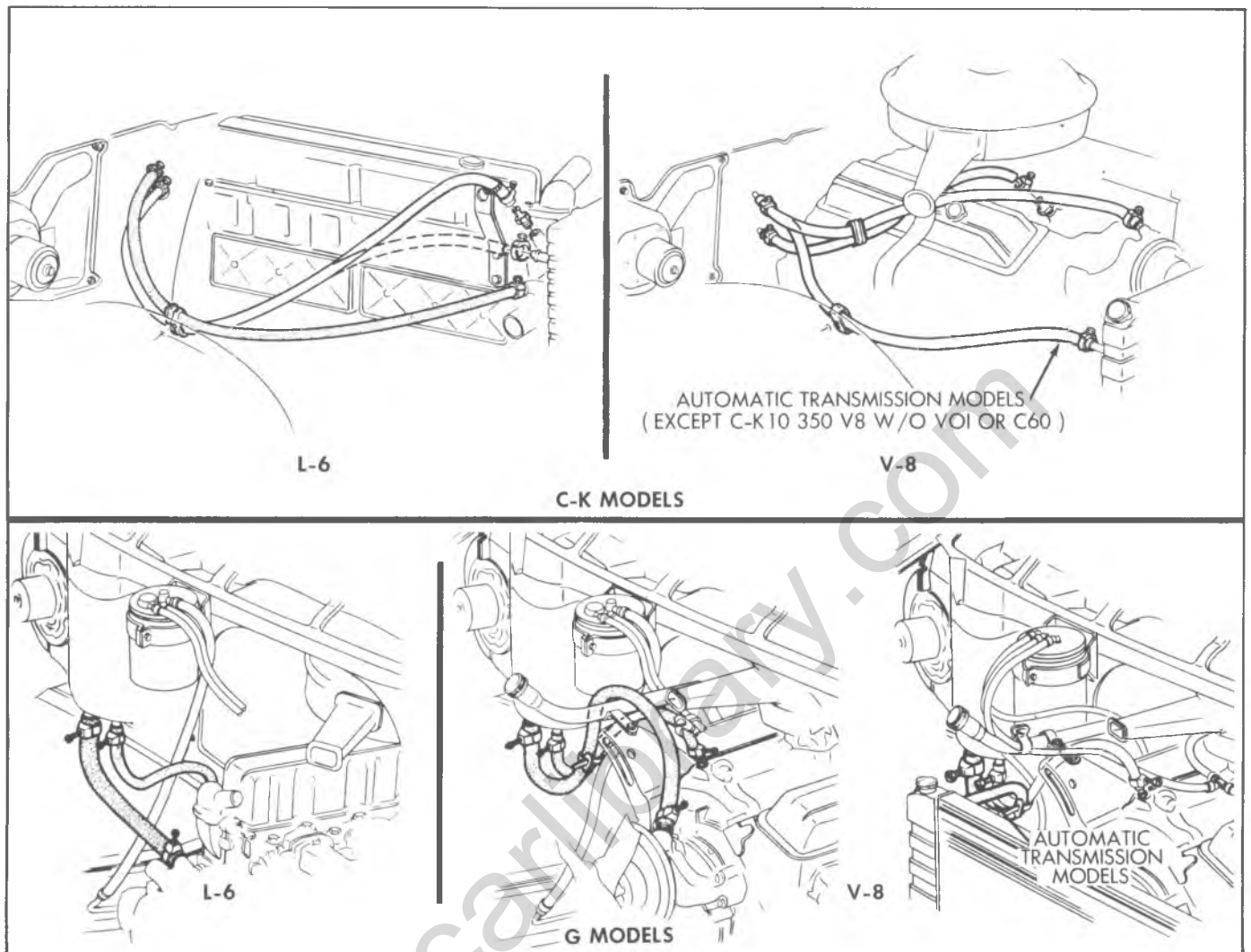

Fig. 7--Heater Hose Routings

2. Unsnap the engine cover front latches. Remove the two cover to floorpan screws and remove the cover.
3. Remove the heater core case and core as an assembly (see "Heater Distributor and Core Replacement").
4. Disconnect the right hand heater outlet hose and the two defroster hoses from the distributor duct.
5. Disconnect the air and defroster door cables by prying off the eyelet clips and removing the cable attaching screws.
6. Pull the center distributor duct to the right and remove it from the vehicle.
7. To install, reverse Steps 1-6 above.

**NOTE:** Check cable and door operation; cables should be free from kinks or binding and doors should close properly. If cable adjustment is necessary, see "Bowden Cable-Adjustment."

### LEFT DISTRIBUTOR DUCT - G Models

#### Replacement (Fig. 8)

1. Disconnect the battery ground cable.
2. Unsnap the engine cover front latches. Remove the two cover to floorpan screws and remove the cover.
3. Remove the duct bracket screw and remove the duct.
4. To install, reverse Steps 1-3.

**NOTE:** All three bowden cables are routed under the duct. It may be necessary to hold the cables down as the duct is being installed. Be sure the left duct is fully installed over the center duct.

### DEFROSTER DUCT

The defroster hose and outlet assemblies are illustrated in Figure 9.

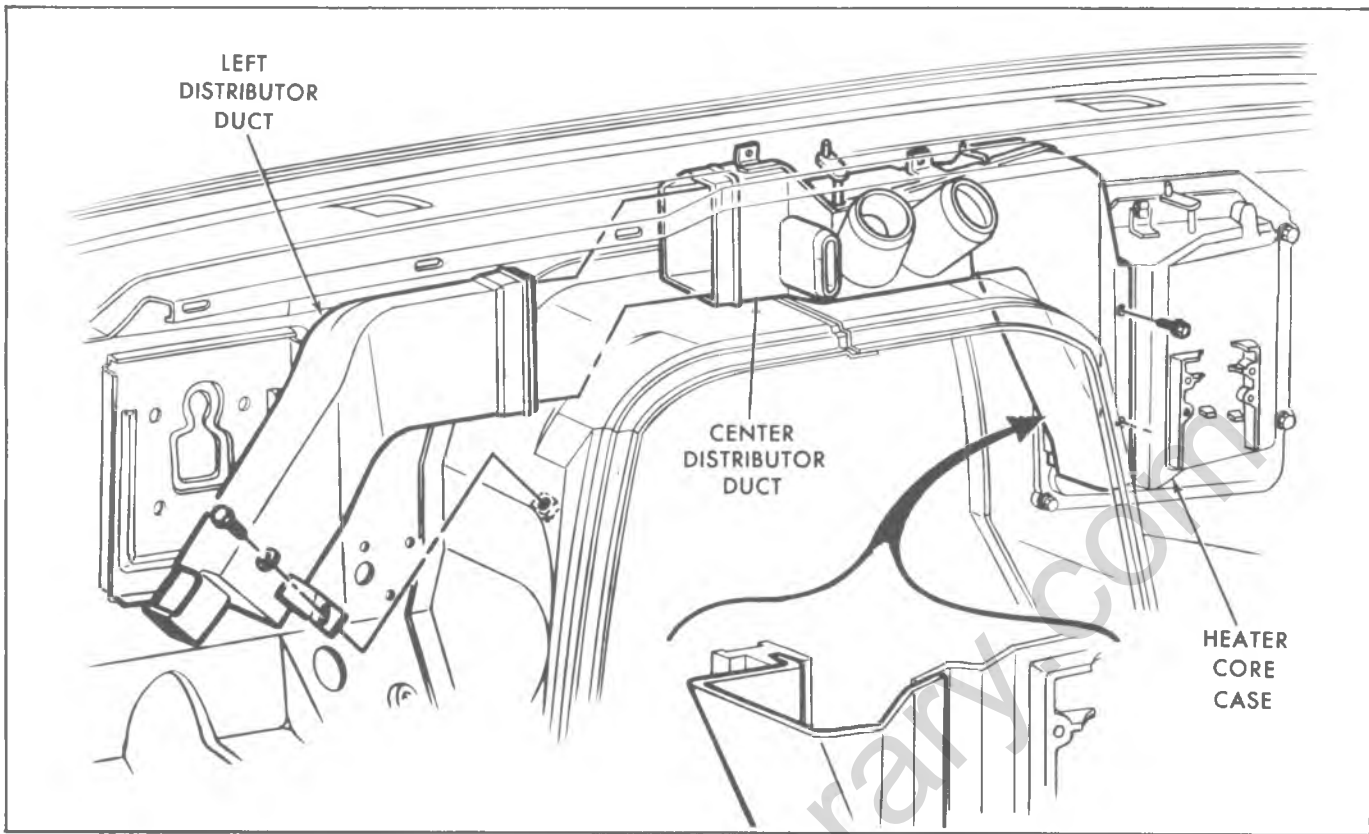

Fig. 8--Distributor Ducts--G Models

## CONTROL ASSEMBLY

### C-K Models

#### Replacement (Fig. 10)

1. Disconnect the battery ground cable.
2. Remove the instrument panel bezel.
3. Disconnect the bowden cables and the blower switch wiring harness.

**CAUTION:** Be careful not to kink the bowden cables.

4. Remove the control through the opening above the control.
5. If a new unit is being installed, transfer the blower switch to the new unit.
6. To reinstall, reverse Steps 1-4 above.

### G Models

#### Replacement (Fig. 11)

1. Disconnect the battery ground cable.
2. Remove the ignition switch from the instrument panel (see Section 12 of this manual).
3. Remove the control to instrument panel mounting

screws and carefully lower the control far enough to gain access to the bowden cable attachments.

**CAUTION:** Care should be taken to prevent kinking the bowden cables while lowering the control.

4. Disconnect the three bowden cables, the control illumination bulb, the blower switch connector and remove the control from the vehicle.
5. Remove the blower switch screws and remove the blower switch.
6. To install, reverse Steps 1-5 above.

## CONTROL CABLES

### C-K Models

#### Replacement

1. Disconnect the battery ground cable.
2. Remove the instrument panel bezel.
3. Remove the control to instrument panel screws.
4. Raise or lower control as necessary to remove cable push nuts and tab attaching screws.
5. Remove glove box and door as an assembly.
6. Remove cable push nut and tab attaching screw at door end of cable.



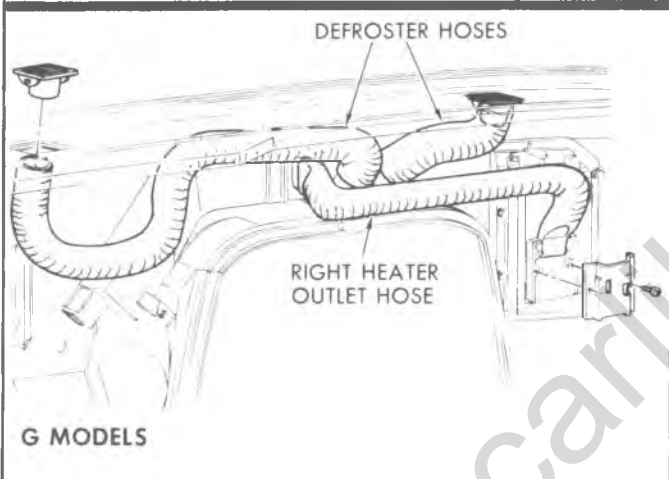
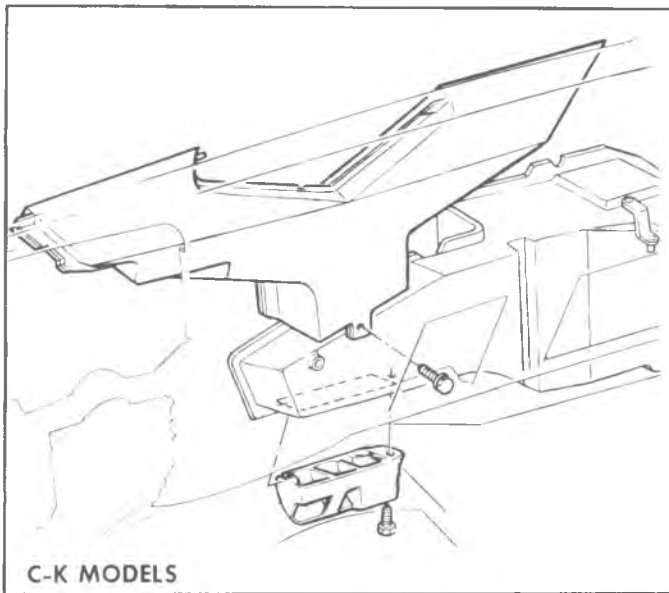

Fig. 9--Defroster Outlets

7. Remove cable from retaining clip and remove cable assembly.
8. To install, reverse Steps 1-7 above.

**CAUTION:** Be careful not to kink the cable during installation. Be sure to route the cable as when removed. Check cable adjustment.

### G Models

#### Replacement (Fig. 12)

1. Disconnect the battery ground cable.
2. Unsnap the engine cover front latches. Remove the two cover to floorpan screws and remove the cover.
3. Remove the left distributor duct attaching screw and remove the duct.
4. Pry off the cable eyelet clip at both the door and control lever. Remove the cable attaching screw at both door and control locations.
5. Attach a 4' piece of wire to the door end of the

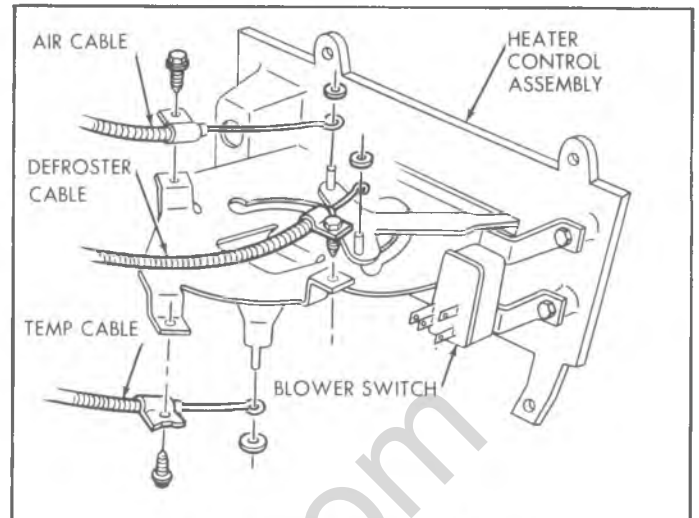

Fig. 10--Control Assembly--C-K Models

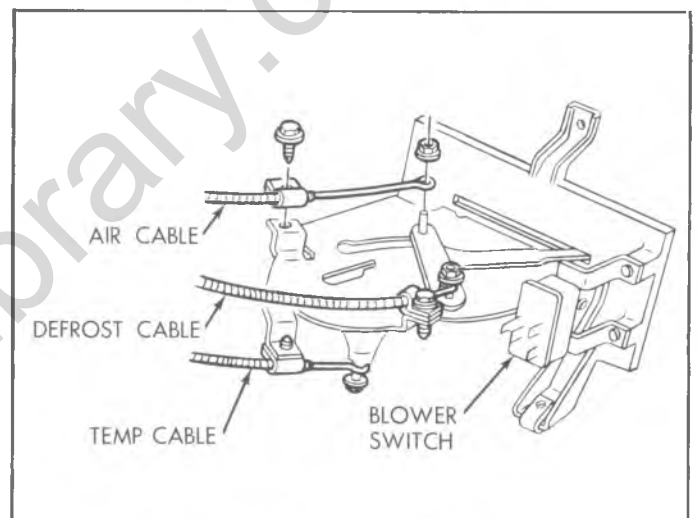

Fig. 11--Control Assembly--G Models

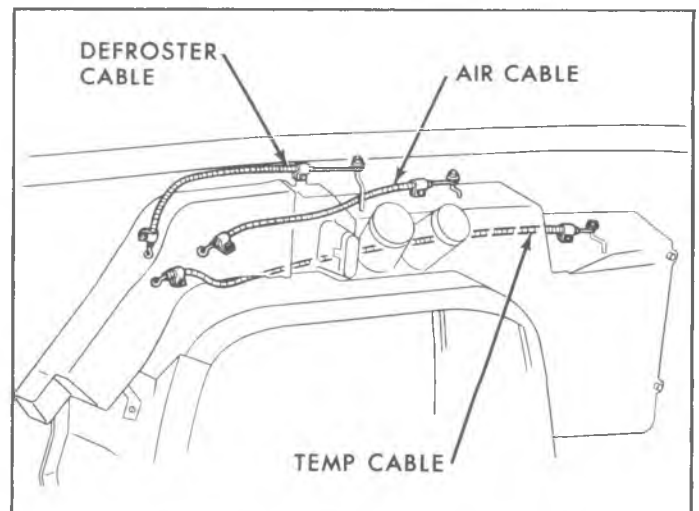

Fig. 12--Control Cable Routing--G Models

## 1A-10 HEATER AND AIR CONDITIONING

cable. Place protective tape around the cable mounting tab and attached wire and carefully pull the cable from the vehicle. Remove the tape and disconnect the 4' piece of wire.

6. To install, attach the new cable to the 4' piece of wire. Tape the mounting tab and attached wire. Carefully pull the new cable into position.
7. Reverse Steps 1-4.

**NOTE:** If cable adjustment is required, see below.

### Adjustment

1. Disconnect the battery ground cable.
  2. **G Model Air and Defroster Door Cables** - Unsnap the engine cover front latches. Remove the two cover to floorpan screws and remove the engine cover.
- C-K Models** - Remove glove box and door as an assembly.
3. Pry off the appropriate cable eyelet clip and disconnect the cable from the door.
  4. Remove the cable retaining screw.
  5. While holding the cable with pliers, rotate the mounting tab on the cable to lengthen or shorten the cable, whichever is required.

**NOTE:** Do not pinch the cable too tightly or damage to the cable could result.

6. Install the cable, reversing Steps 1-4 above.

## BLOWER SWITCH

### C-K Models

#### Replacement (Fig. 10)

1. Disconnect the battery ground cable.
2. Remove the instrument panel bezel.
3. Remove the control to instrument panel screws and lower the control onto the radio.
4. Disconnect the switch electrical harness.
5. Remove the switch attaching screws and remove the switch.
6. To install, reverse Steps 1-5 above.

### G Models

#### Replacement (Fig. 11)

1. Disconnect the battery ground cable.
2. Disconnect the blower switch wiring harness connector at the switch.
3. Remove the two switch attaching screws and remove the switch assembly.
4. To install a new switch, reverse Steps 1-3 above.

## RESISTOR

#### Replacement (Figs. 4 and 6)

1. Disconnect the wiring harness at the resistor connector.
2. Remove the two resistor mounting screws and remove the resistor.
3. To install a new resistor, reverse Steps 1 and 2 above.

## DIAGNOSIS

TROUBLE	CAUSE AND CORRECTION
Temperature of heater air at outlets too low to heat up passenger compartment.	1. See "Insufficient Heat Diagnostic Chart".
Temperature of heater air at outlets adequate but the vehicle will not build up sufficient heat.	<p>Check for body leaks such as:</p> <ol style="list-style-type: none"> <li>1. Floor side kick pad ventilators partially open.</li> <li>2. Leaking grommets in dash.</li> <li>3. Leaking welded seams along rocker panel and windshield.</li> <li>4. Leaks through access holes and screw holes.</li> <li>5. Leaking rubber molding around door and windows.</li> <li>6. Leaks between sealing edge of blower and air inlet assembly and dash, and between sealing edge of heater distributor assembly and dash.</li> </ol>
Inadequate defrosting action.	<ol style="list-style-type: none"> <li>1. Check that DEFROST lever completely opens defroster door in DEF position - Adjust if necessary.</li> <li>2. Insure that temperature and air doors open fully - Adjust.</li> <li>3. Look for obstructions in defroster ducts - Remove any obstructions.</li> <li>4. Check for air leak in ducting between defroster outlet on heater assembly and defroster duct under instrument panel - Seal area as necessary.</li> <li>5. Check position of bottom of nozzle to heater locating tab - Adjust.</li> <li>6. Check position of defroster nozzle openings relative to instrument panel openings. Mounting tabs provide positive position if properly installed.</li> </ol>
Inadequate circulation of heated air through vehicle.	<ol style="list-style-type: none"> <li>1. Check heater air outlet for correct installation - Reinstall.</li> <li>2. Inspect floor carpet to insure that carpet lies flat under front seat and does not obstruct air flow under seat, and also inspect around outlet ducts to insure that carpet is well fastened to floor to prevent cupping of air flow - Correct as necessary.</li> </ol>
Erratic heater operation.	<ol style="list-style-type: none"> <li>1. Check coolant level - Fill to proper level.</li> <li>2. Check for kinked heater hoses - relieve kinks or replace hoses.</li> <li>3. Check operation of all bowden cables and doors - Adjust as necessary.</li> <li>4. Sediment in heater lines and radiator causing engine thermostat to stick open - flush system and clean or replace thermostat as necessary.</li> <li>5. Partially plugged heater core - backflush core as necessary.</li> </ol>
Hard operating or broken controls.	<ol style="list-style-type: none"> <li>1. Check for loose bowden cable tab screws or mis-adjusted bowden cables - Correct as required.</li> <li>2. Check for sticking heater system door(s) - Lubricate as required using a silicone spray.</li> </ol>

# 1A-12 HEATER AND AIR CONDITIONING

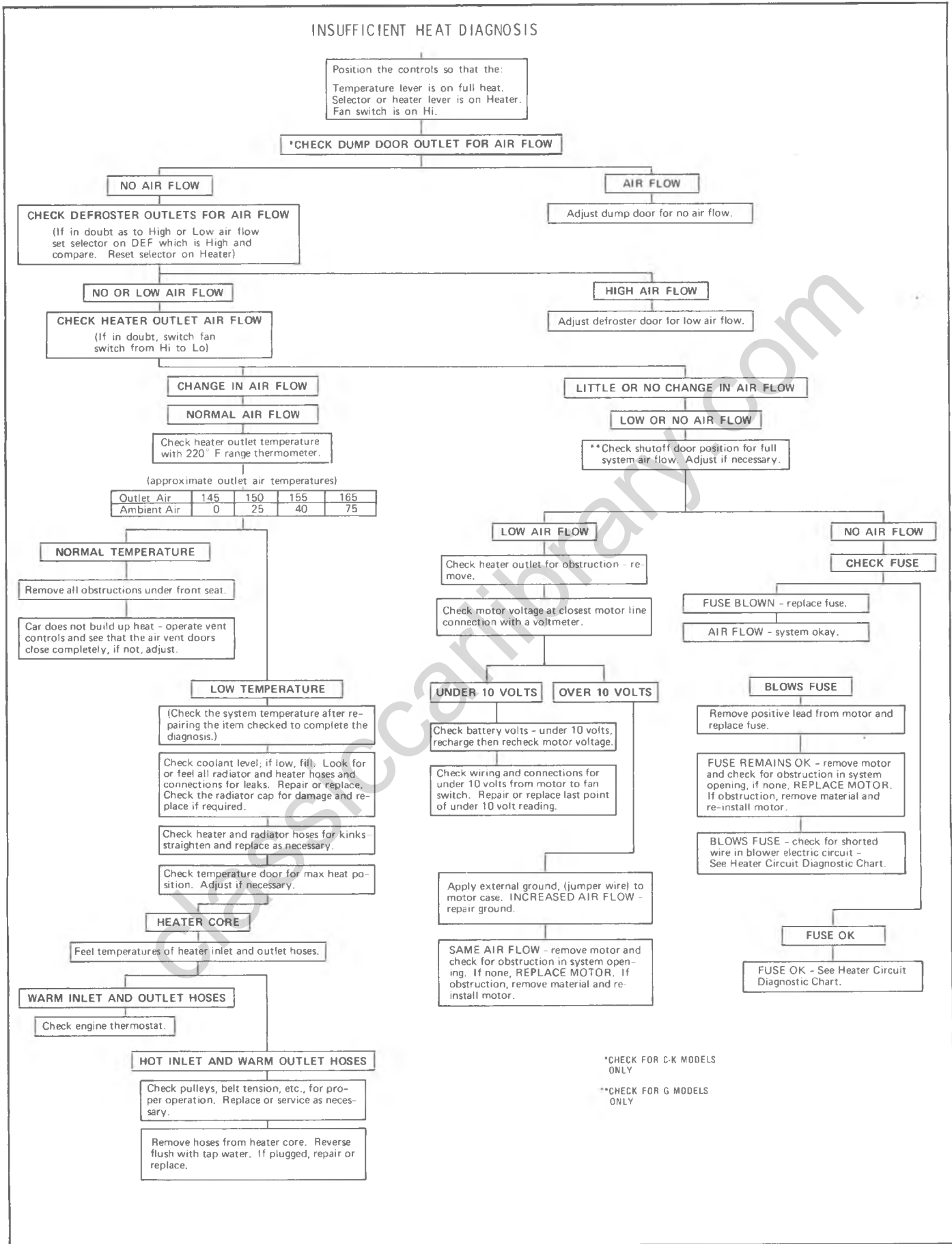

### HEATER CIRCUIT DIAGNOSIS\*

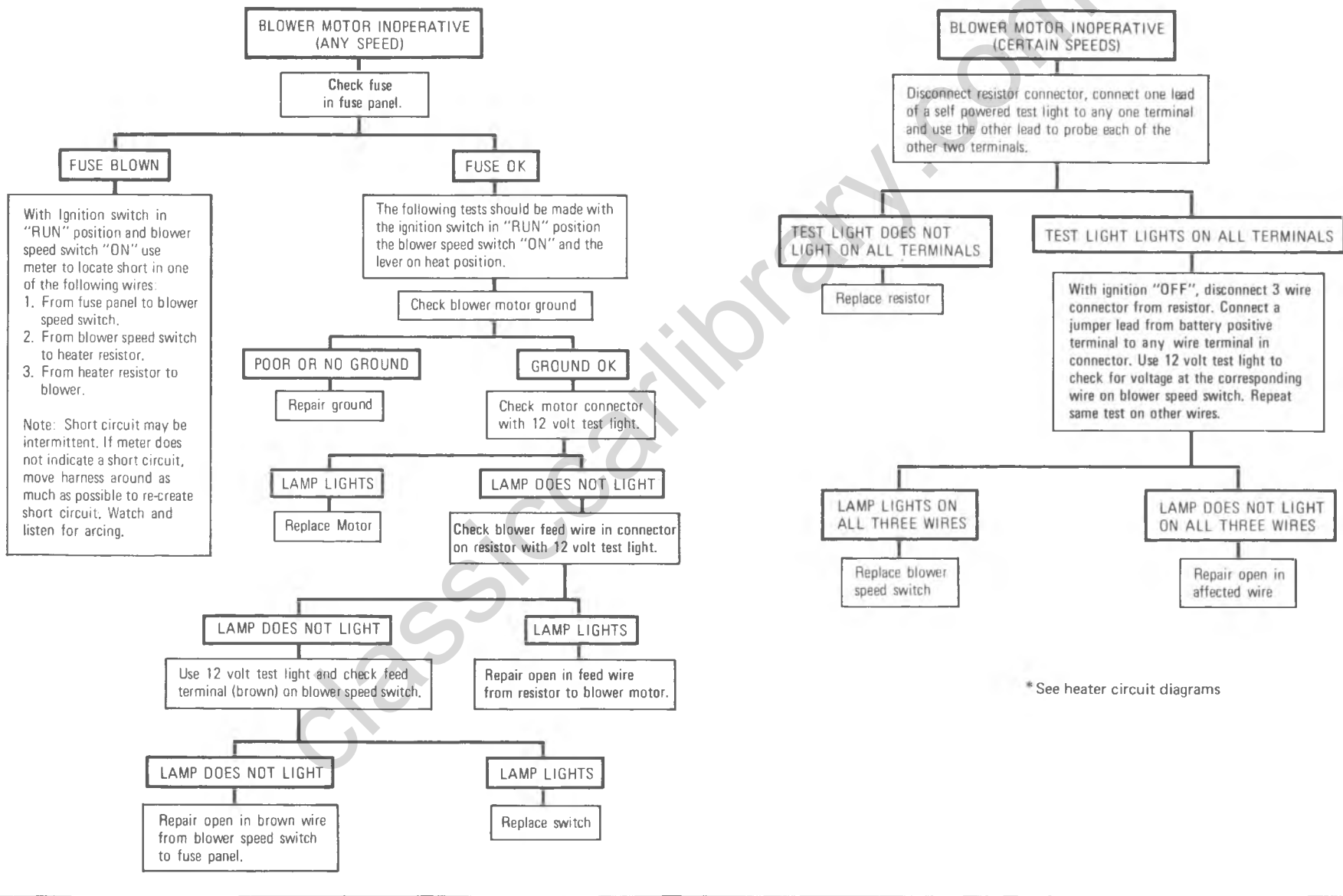

\* See heater circuit diagrams

Fig. 13-Heater Circuit Diagnosis

1A-14 HEATER AND AIR CONDITIONING

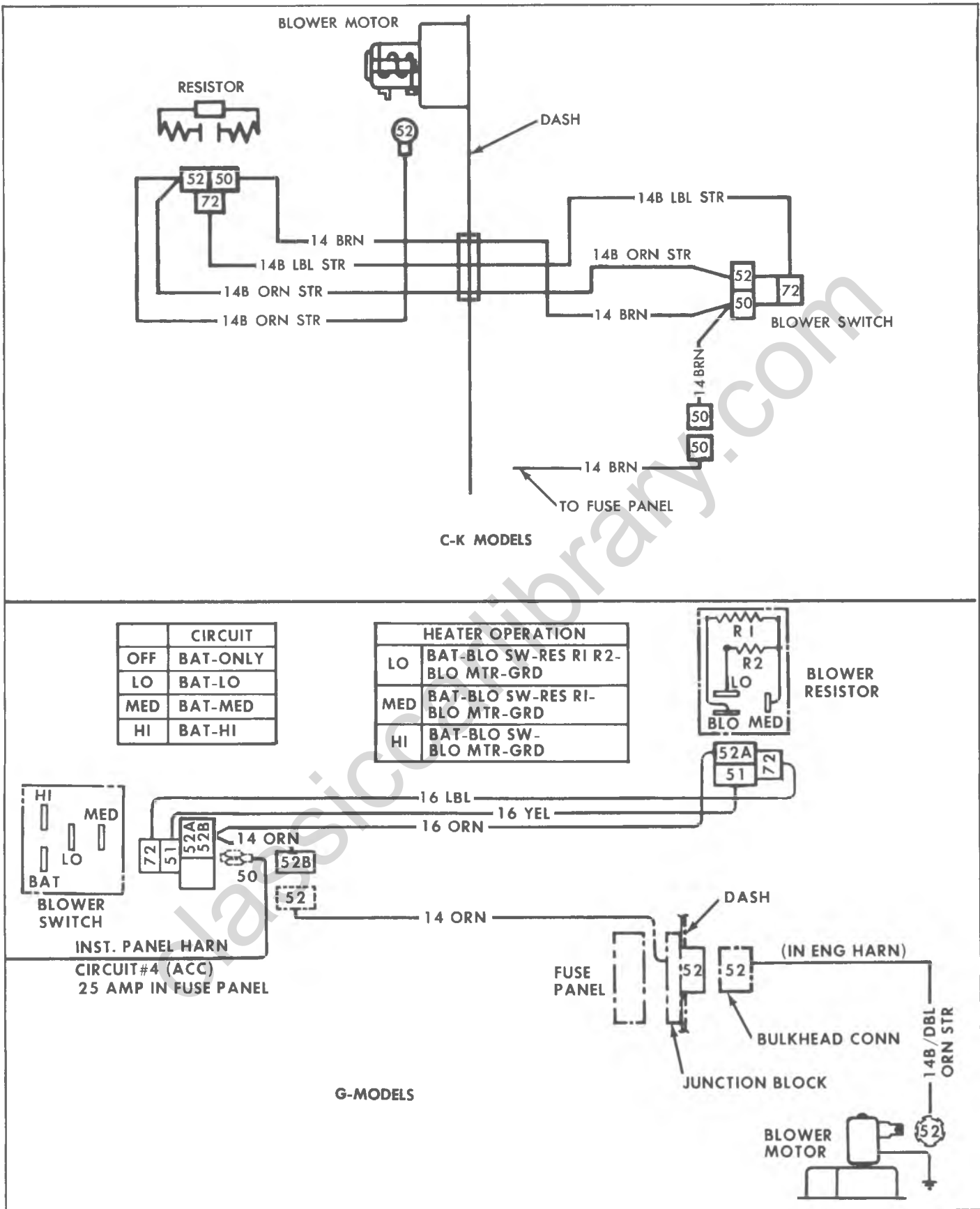

Fig. 14-Heater Wiring Diagrams

## AUXILIARY HEATER

### INDEX

General Description .....	1A-15
Controls .....	1A-15
Component Replacement and Repairs.....	1A-17
Diagnosis.....	1A-18

### GENERAL DESCRIPTION

An auxiliary heater is available as a dealer installed accessory to provide additional heating capacity for the rearmost extremities of the C-K (06) and G (05 and 06) models.

This unit operates entirely independent of the standard heater and is regulated through its own controls at the instrument panel.

This system consists of a separate core and fan unit mounted as shown in Figures 15 and 16.

Heater hoses extend from the unit to the front of the vehicle where they are connected to the standard heater hoses with "tees". An "on-off" water valve is installed in the heater core inlet line in the engine compartment.

This valve must be operated manually--"on" for cold weather, "off" in warm weather. The purpose of the valve is to cut off coolant flow to the auxiliary core during warm weather and eliminate the radiant heat that would result.

#### CONTROLS

Two methods of control are employed with this system:

#### Water Valve (Fig. 17)

When heat is desired, the water valve must be in the "on" position (valve located in the engine compartment

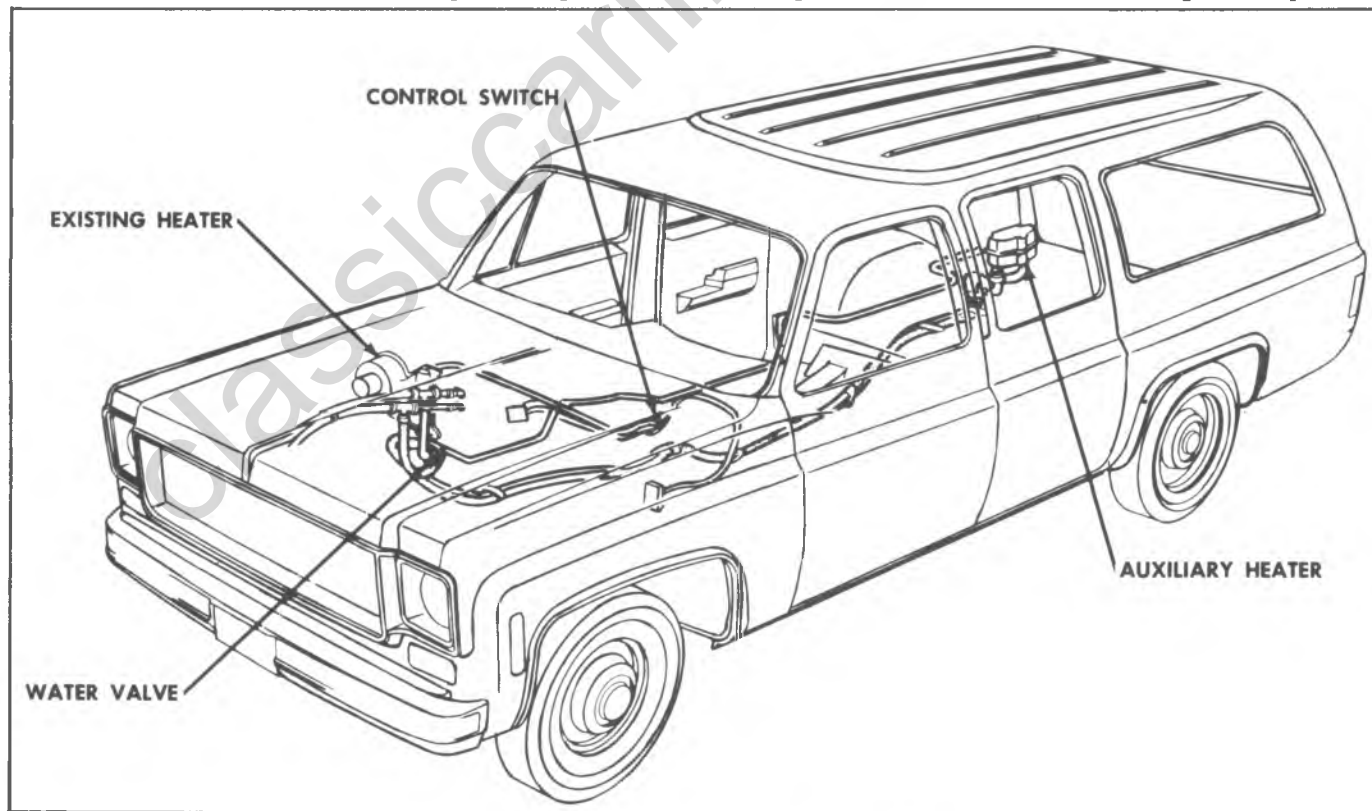

Fig. 15--Auxiliary Heater Installations (C-K Models)

1A-16 HEATER AND AIR CONDITIONING

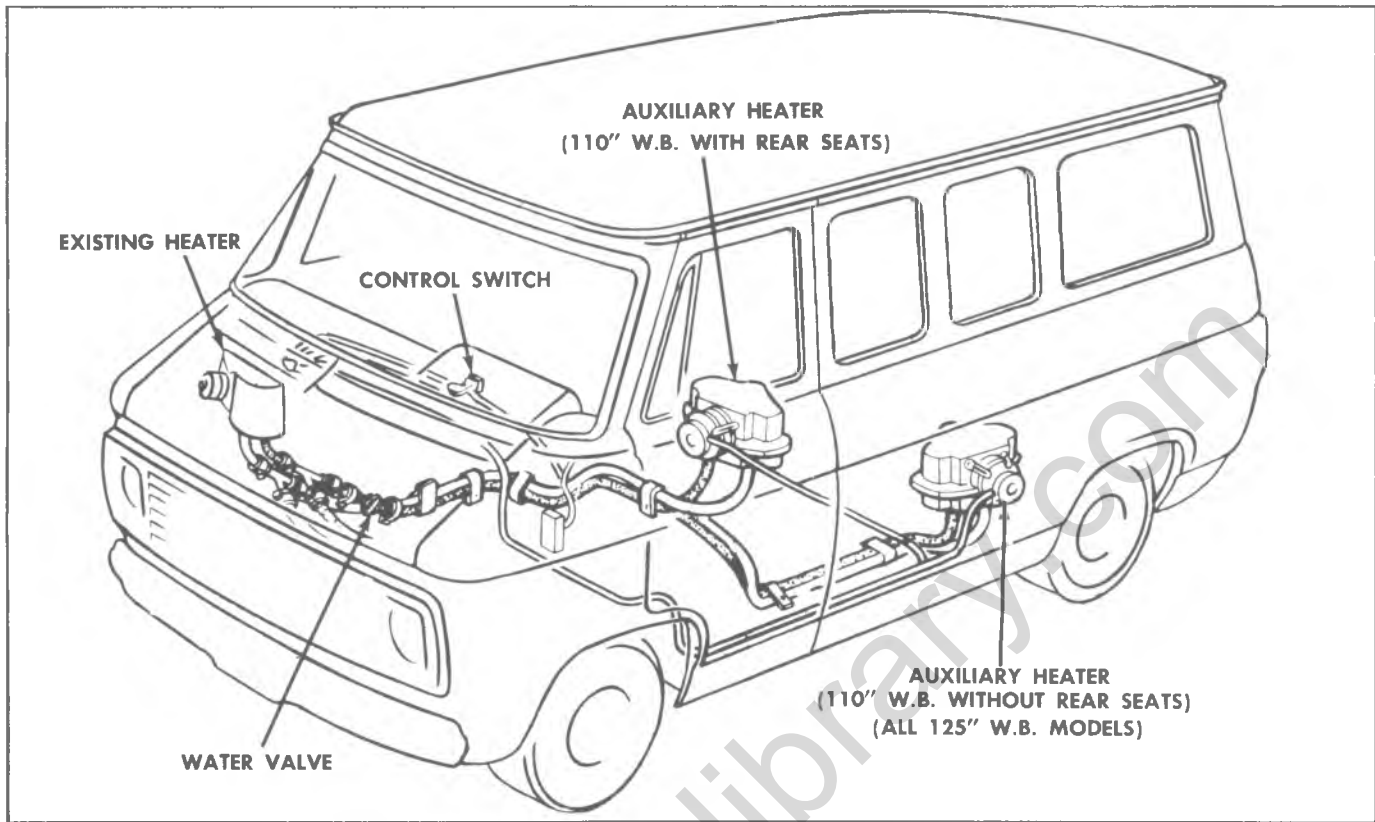

Fig. 16--Auxiliary Heater Installations (G Models)

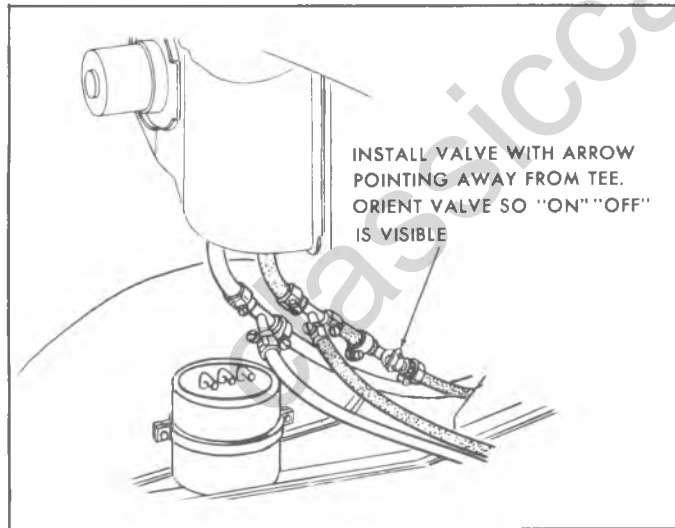

Fig. 17--Water Valve Installation - G Model Shown as Typical



Fig. 18--Auxiliary Heater Control

in the core inlet line). During the summer months, this valve should be placed in the "off" position.

**Fan Switch (Fig. 18)**

The three speed fan switch (LOW-MED-HI) is located in

the instrument panel, to the right of the steering column. Fully down, the blower is inoperative; fully up the blower is on HI.



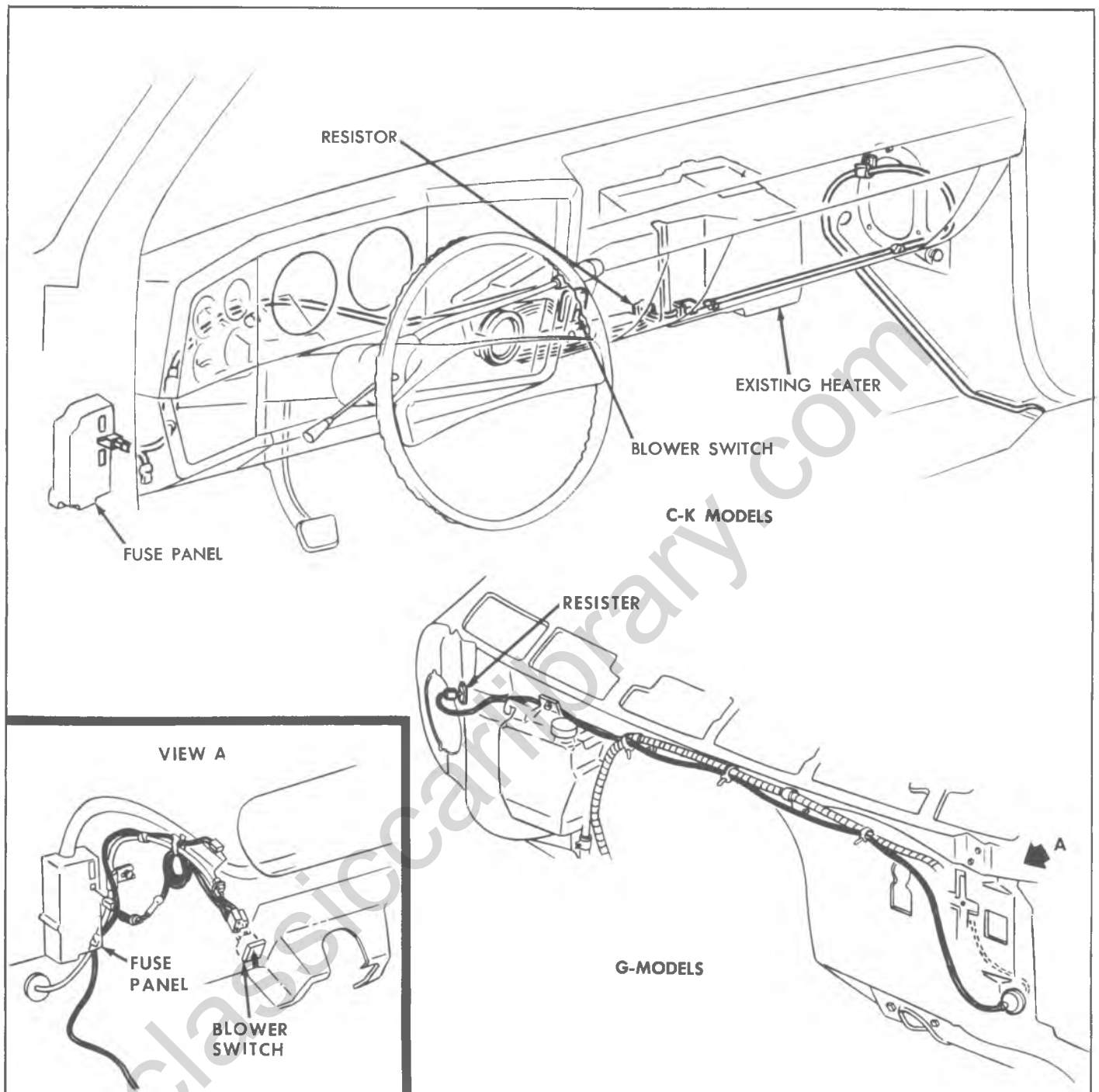

Fig. 19--Control and Resistor Mountings

## COMPONENT REPLACEMENT AND REPAIRS

Since a detailed list of installation instructions is included with the auxiliary heater unit, replacement procedures will not be repeated in this section.

**CAUTION:** *G Models*--When replacing heater hoses, maintain a 1/2" minimum clearance between hose clip and upper control arm, a

1-1/2" minimum clearance between hoses and propshaft and a 1-1/4" minimum clearance between the auxiliary heater core lines and the exhaust pipe as shown in Figure 20.

*All Models*--Draw hoses tight to prevent sag or rub against other components. Be sure to route hoses through all clamps as originally installed.

# 1A-18 HEATER AND AIR CONDITIONING

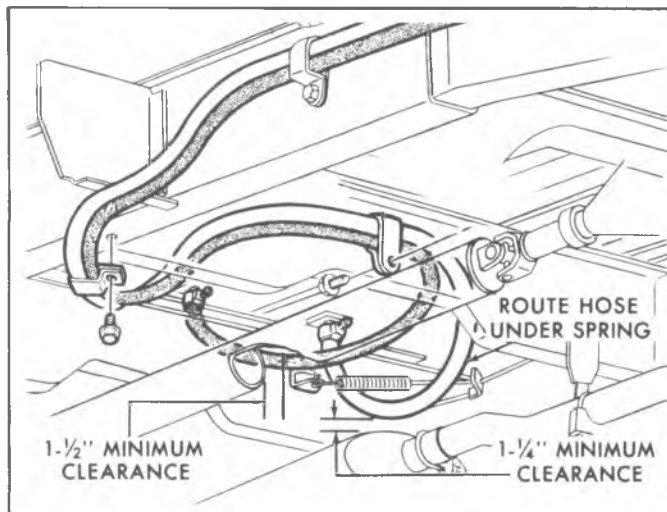

Fig. 20-Heater Hose Routing - G Models

## DIAGNOSIS

Refer to the "Standard Heater" section of this manual for diagnostic information; see Electrical Diagram Figure 21.

inoperative on C-K models (equipped with Overhead Air Conditioning), check that the connectors have not been interchanged with one another.

NOTE: If the heater blower motor is

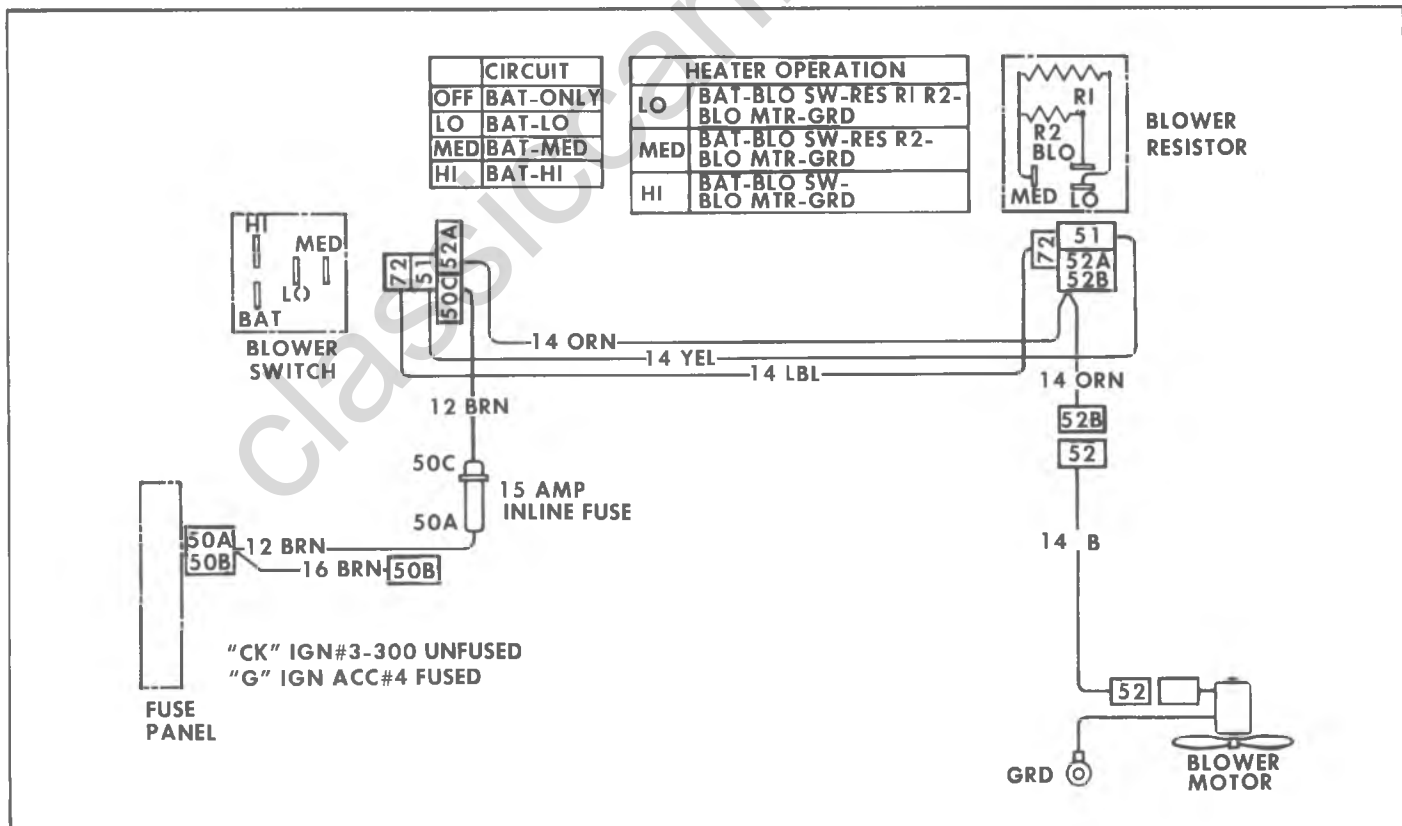

Fig. 21-Electrical Diagram - All Models

# AIR CONDITIONING

## INDEX

General Description .....	1A-22	Collision Procedure--All Vehicles.....	1A-60
Four-Season System (C-K Models).....	1A-22	Component Part Replacement--Four-Season	
C60 System (G Models).....	1A-22	System--C-K Models.....	1A-61
Overhead Systems (C-K-G Models).....	1A-22	Condenser.....	1A-61
Motor Home Chassis System.....	1A-22	Accumulator.....	1A-62
Theory of Operation.....	1A-22	Blower Assembly.....	1A-62
Heat.....	1A-22	Evaporator Core.....	1A-62
Refrigerants.....	1A-25	Expansion Tube.....	1A-63
Air Conditioning.....	1A-28	Selector Duct and Heater Core.....	1A-63
Basic Air Conditioner.....	1A-29	Kick Panel Air Valve.....	1A-64
Main Units of the System.....	1A-31	Plenum Air Valve.....	1A-64
Chemical Ingredients of an Air Conditioning		Control Assembly.....	1A-65
System.....	1A-37	Temperature Door Cable Adjustment.....	1A-65
Primary Causes of System Failures.....	1A-38	Master Switch and/or Blower Switch.....	1A-65
System Controls.....	1A-40	Vacuum Tank.....	1A-65
General Information.....	1A-42	Blower Resistor Unit.....	1A-66
Precautions in Handling Refrigerant-12.....	1A-42	Blower Motor Relay.....	1A-66
Precautions in Handling Refrigerant Lines.....	1A-43	Thermostatic Switch.....	1A-66
Maintaining Chemical Stability in the		Discharge Pressure Switch.....	1A-67
Refrigeration System.....	1A-43	Fuse.....	1A-67
J-8393 Charging Station.....	1A-44	Component Part Replacement	
Gauge Set.....	1A-44	Overhead System--C-K Models.....	1A-68
Vacuum Pump.....	1A-44	Rear Duct.....	1A-68
Leak Testing the System.....	1A-45	Blower Motor Resistor.....	1A-68
Availability of Refrigerant-12.....	1A-46	Blower Motor Assembly.....	1A-69
Compressor Oil.....	1A-46	Expansion Valve.....	1A-70
Compressor Serial Number.....	1A-46	Evaporator Core.....	1A-70
Inspection and Periodic Service.....	1A-47	Blower Motor Switch.....	1A-71
Pre-Delivery Inspection.....	1A-47	Fuse.....	1A-71
6000 Mile Inspection.....	1A-47	Component Part Replacement	
Periodic Service.....	1A-47	C60 System--G Models.....	1A-71
Evacuating and Charging Procedures.....	1A-47	Condenser.....	1A-71
Air Conditioning System Capacity.....	1A-47	Receiver-Dehydrator.....	1A-72
Installing Charging Station.....	1A-47	Sight Glass Replacement.....	1A-72
Purging the System.....	1A-48	A/C Air Distributor Duct.....	1A-72
Evacuating and Charging the System.....	1A-48	A/C Center and Right Dash Outlets,	
Performance Test.....	1A-51	Heater, Air Distributor and Extension Ducts.....	1A-72
Performance Data.....	1A-51	Heater Core Case and Core.....	1A-73
Checking Oil.....	1A-51	Expansion Valve.....	1A-73
Refrigerant Quick-Check Procedure.....	1A-53	Blower Motor.....	1A-74
Maintenance and Adjustments.....	1A-54	Evaporator Core.....	1A-75
Thermostatic Switch.....	1A-54	Air Inlet Valve.....	1A-75
Potentiometer (G Models).....	1A-55	Temperature Door Cable.....	1A-76
Expansion Valve.....	1A-55	Control.....	1A-76
Engine Idle Compensator.....	1A-56	Blower Switch.....	1A-76
General Repair Procedures.....	1A-56	Amplifier Circuit Board.....	1A-76
Preparing System for Replacement of Component		Resistors.....	1A-76
Parts.....	1A-56	Blower Motor Relay.....	1A-77
Foreign Material in the System.....	1A-56	Discharge Pressure Switch.....	1A-77
Refrigerant Line Connections.....	1A-57	Vacuum Tank.....	1A-78
Repair of Refrigerant Leaks.....	1A-58	Circuit Breaker.....	1A-78
Refrigerant Hose Failure.....	1A-58	Component Part Replacement	
Compressor.....	1A-58	Overhead System--G Models.....	1A-78
Compressor Failure.....	1A-60	Blower-Evaporator Shroud.....	1A-78
False Compressor Seizure.....	1A-60	Blower Motor Assemblies.....	1A-78

# 1A-20 HEATER AND AIR CONDITIONING

Expansion Valves .....	1A-79	Blower Assembly .....	1A-83
Evaporator Core .....	1A-80	Expansion Valve, Evaporator Case or Core .....	1A-83
Resistor .....	1A-80	Thermostatic and/or Blower Switches .....	1A-84
Blower Switch .....	1A-81	Resistor .....	1A-84
Rear Blower Relay .....	1A-81	Fuse .....	1A-84
Tie Relay .....	1A-81	Diagnosis .....	1A-84
Component Part Replacement		Refrigerant System .....	1A-84
Dash Mounted System--Motor Home Units .....	1A-81	Compressor Diagnosis .....	1A-87
Condenser .....	1A-81	Insufficient Cooling .....	1A-88
Receiver-Dehydrator .....	1A-82	Electrical System Diagnosis .....	1A-90
Sight Glass .....	1A-82	Vacuum System Diagnosis .....	1A-93
Blower-Evaporator Assembly .....	1A-82	Special Tools .....	1A-99

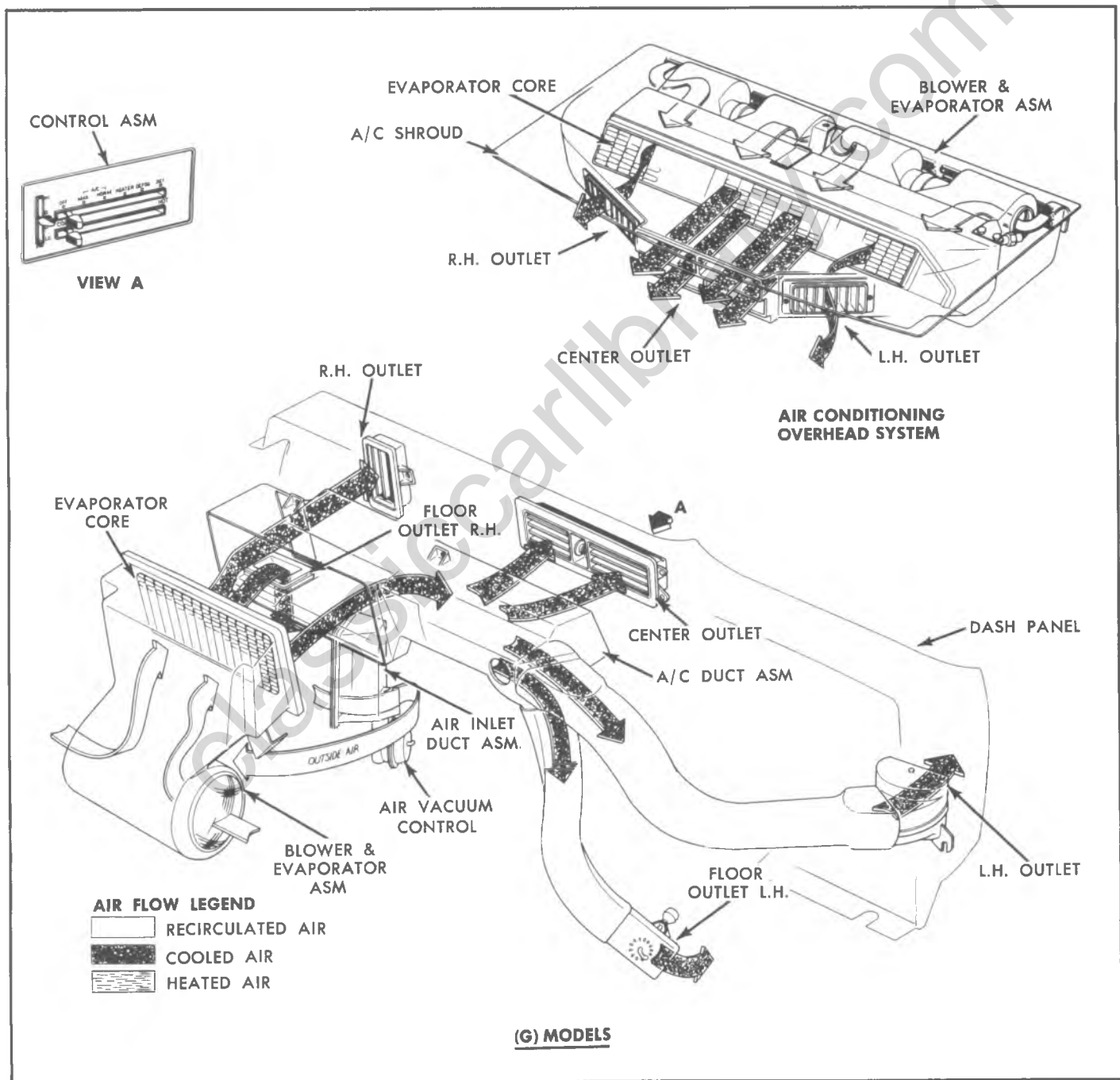

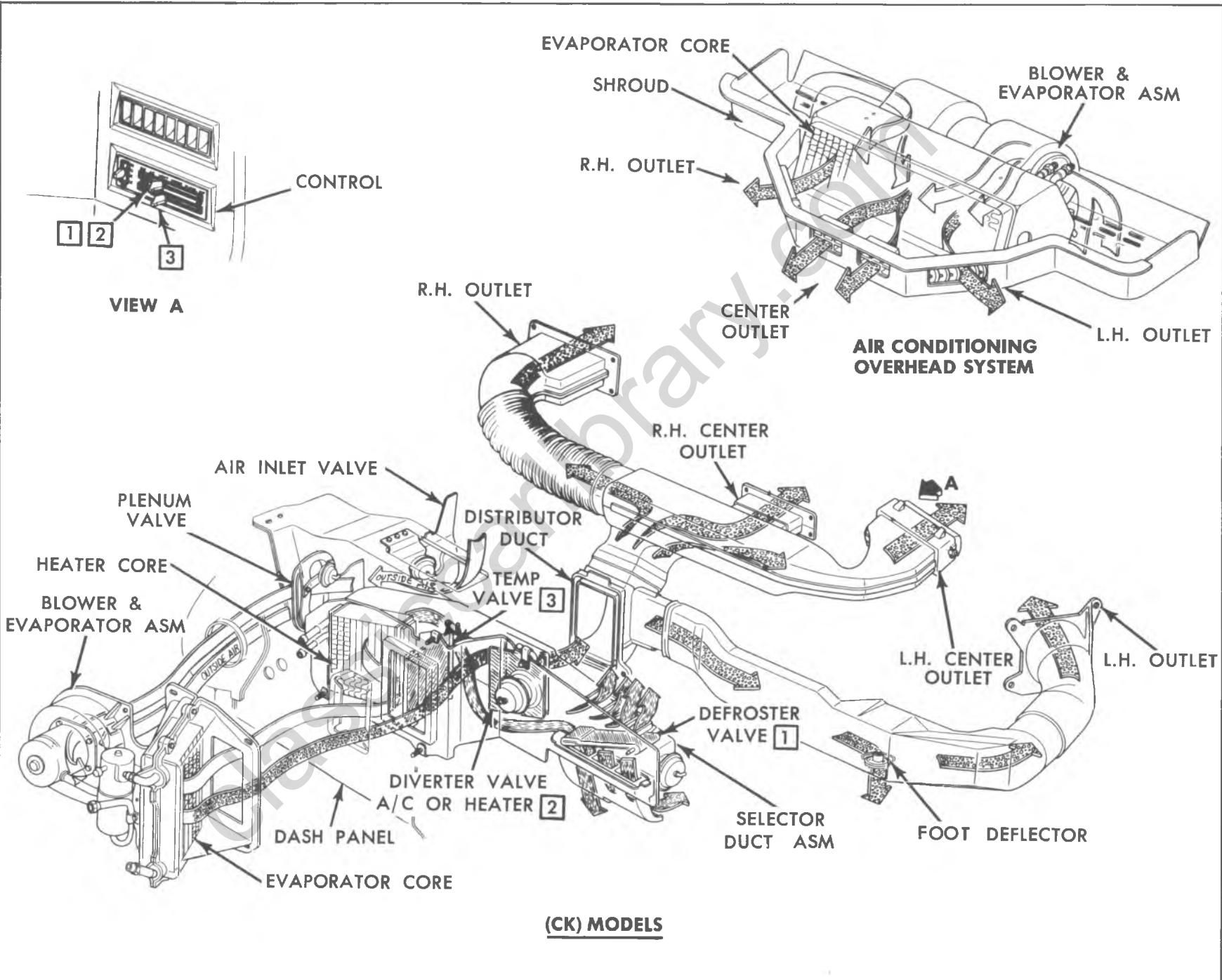

## GENERAL DESCRIPTION

### FOUR-SEASON SYSTEM (C-K MODELS)

Both the heating and cooling functions are performed by this system. Air entering the vehicle must pass through the cooling unit (evaporator) and through (or around) the heating unit, in that order, and the system is thus referred to as a "reheat" system.

The evaporator provides maximum cooling of the air passing through the core when the air conditioning system is calling for cooling. A thermostatic switch, located in the blower-evaporator case, acts to control compressor operation by sensing the fin temperature of the evaporator core.

System operation is as follows: Air, either outside air or recirculated air, enters the system and is forced through the system by the blower. As the air passes through the evaporator core, it receives maximum cooling if the air conditioning controls are calling for cooling. After leaving the evaporator, the air enters the Heater and Air Conditioner Selector Duct Assembly where, by means of diverter doors, it is caused to pass through or to bypass the heater core in the proportions necessary to provide the desired outlet temperature. Conditioned air then enters the vehicle through either the floor distributor duct or the dash outlets. When, during cooling operations, the air is cooled by the evaporator to below comfort level, it is then warmed by the heater to the desired temperature. During "heating only" operations, the evaporator will not be in operation and ambient air will be warmed to the desired level in the same manner.

The dash outlets are rectangular in design. The outlets can be rotated horizontally or vertically to direct air as desired. Under the left distributor duct is located a floor cooler which can be rotated to provide cooling air or shut off completely.

### C60 SYSTEM (G MODELS)

This system performs both the heating and cooling functions; however, the heating and cooling systems operate independently of one another -- the system provides either heating or cooling and thus is referred to as a "parallel system".

In the air conditioning modes, air (either a mixture of inside and outside at NORM or inside air only at MAX) enters the system and passes through the evaporator core (receiving maximum cooling) and is then directed into the passenger compartment through the dash outlets and foot coolers.

A thermister clipped to the evaporator core is used to control compressor operation by sensing air temperature as it leaves the evaporator core. As the core temperature

increases the resistance of the thermister to 400 ohms, the amplifier (on the control) furnishes current to energize the compressor clutch coil. As the evaporator cools down, the temperature of the thermister decreases which biases the amplifier off and compressor clutch coil is de-energized.

The dash outlets are rectangular in design and can be rotated horizontally or vertically to direct air as desired. Foot coolers are provided on both driver and passenger side.

In the heater-defrost modes, the air conditioning outside air door is closed. The heater air door is open and outside air is allowed to pass through the heater core (receiving maximum heating) and is then directed into the passenger compartment through the heater and/or defroster outlets.

### OVERHEAD SYSTEMS (C-K-G MODELS)

These systems (C69 on C-K-G Models) operate in conjunction with the Four-Season System (C-K Models) or C60 System (G Models)--they do not operate independently.

NOTE: Overhead system kits are available for non-factory installation on C-K Models, providing the vehicle is equipped with the front system.

These units are self contained, operating on inside (recirculated) air only. Air is drawn into the unit, passed through the evaporator core and then directed into the passenger compartment through adjustable outlets in the air distributor duct.

System control is through the front system. The only control on the overhead system is a three speed blower switch.

### MOTOR HOME CHASSIS SYSTEM

This system performs the cooling functions only. When heating (above ambient temperatures) is desired, the vehicle heater must be used. When air conditioning is desired, the heater should be completely shut off.

This self-contained unit is bracket mounted to the dash by the body manufacturer. It operates on inside (recirculated) air only. Air is drawn into the unit, passed through the evaporator core (receiving maximum cooling) and then directed into the vehicle through adjustable outlets.

A thermostatic switch, located on the face plate is used to control compressor operation by sensing air temperature as it leaves the evaporator core.

## THEORY OF OPERATION

### HEAT

We all know what air conditioning does for us but very few understand how or why it works. An air conditioner

is functionally very similar to a refrigerator. A refrigerator is a simple mechanism which, surprisingly

enough, works quite a bit like a teakettle boiling on a stove. That may sound far-fetched, but there is more similarity between the two than most of us would suspect. A modern refrigerator can make icecubes and keep food cool and fresh only because a liquid called the refrigerant boils inside the freezer.

Everyone knows a boiling teakettle is "hot" and a refrigerator is "cold". We usually think of "cold" as a definite, positive condition. The only way we can define it is in a rather negative sort of way by saying "cold" is simply the lack of heat, just as darkness is the lack of light. We can't make things cold directly. All we can do is remove some of the heat they contain and they will become cold as a result. And that is the main job of any icebox or refrigerator. Both are simply devices for removing heat.

All substances contain some heat. Theoretically, the lowest temperature that any substance could obtain is 459° Fahrenheit below Zero. This is called "absolute zero" and anything warmer than this contains heat. Since man has never succeeded in getting all the heat out of an object, we must think about the transfer of heat from one object to another when talking about controlling temperatures.

**Transfer of Heat**

The only thing that will attract heat is a colder object. Like water, which always flows downhill, heat always flows down a temperature scale - from a warm level down to a colder one. When we hold our hands out toward the fireplace, heat flows from the hot fire out to our cold hands (fig. 22). When we make a snowball, heat always flows from our warm hands to the colder snow. In an icebox, the ice always is colder than the stored food, so heat is drawn out of the warm food by the colder ice.

**Measurement of Heat**

Everyone thinks he knows how heat is measured. Thermometers are used in every home. (Whenever we

speaking of temperature from now on, we will mean Fahrenheit). They can tell how hot a substance is, but they can't tell us everything about heat.

When we put a teakettle on a stove, we expect it to get hotter and hotter until it finally boils. All during the process, we can tell exactly how hot the water is by means of a thermometer (fig. 23). Our thermometer will show us that the flame is just as hot when we first put the teakettle on the stove as it is when the water finally boils. Why doesn't the water boil immediately? Why does it take longer to boil a quart of water than a cupful? Obviously temperature isn't the only measurement of heat.

Even though heat is intangible, it can be measured by quantity as well as intensity. Thermometers indicate only the intensity of heat. The unit for measuring quantity of heat is specified as that amount necessary to make 1 pound of water 1 degree warmer (fig. 24). We call this quantity of heat a British Thermal Unit. Oftentimes, it is abbreviated to B.T.U.

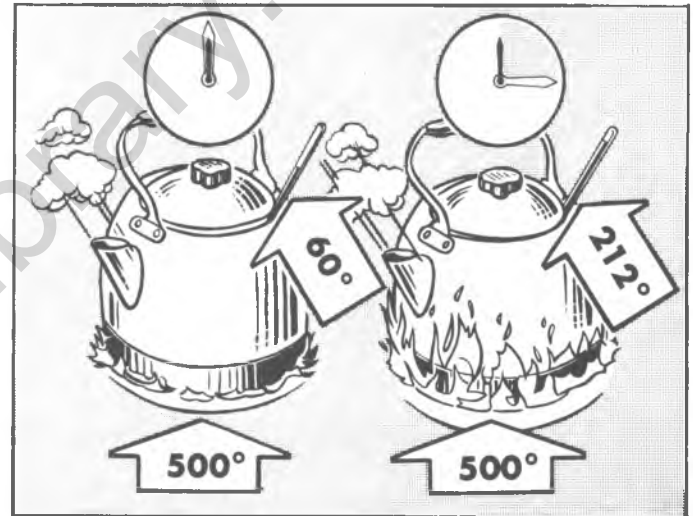

Fig. 23--Measurement of Heat

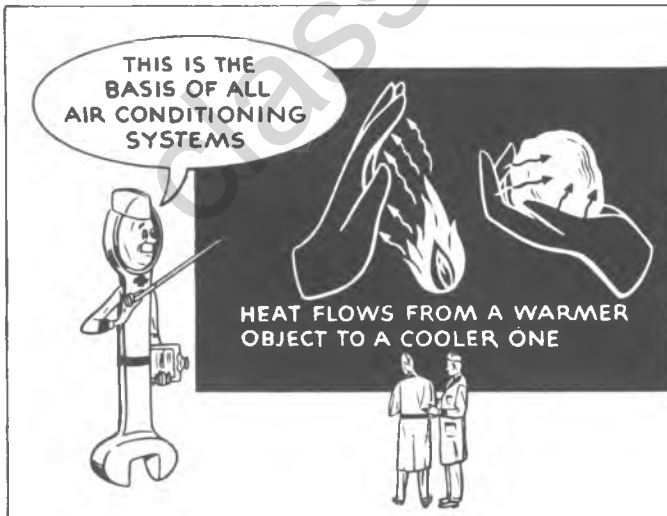

Fig. 22--Heat Transfer

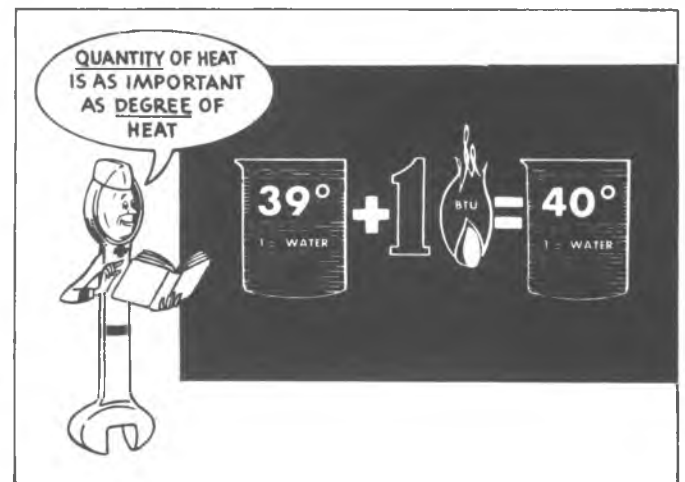

Fig. 24--Quantity of Heat = B.T.U.

## 1A-24 HEATER AND AIR CONDITIONING

Perhaps we can get a better idea of these two characteristics of heat if we think of heat as a sort of coloring dye. If we add one drop of red dye to a glass of water, it will turn slightly pink. Another drop will make the water more reddish in color (fig. 25). The more drops of dye we add, the redder the water will get. Each drop of dye corresponds to 1 B.T.U. and the succeeding deeper shades of red are like increases in temperature.

It may seem a little puzzling to talk about heat in a book on air conditioning...but, when you stop to think about it, we are handling heat exclusively. Although we ordinarily think of an air conditioner as a device for making air cold, it does that indirectly. What it does is to take heat away from the air and transfer that heat outside the vehicle.

We know now that cold is nothing more than the absence of heat, and that heat always flows from a warm object to a colder one. We also have a clearer idea of how heat is measured.

From everything we've learned about heat so far, it seems to behave in a perfectly normal manner. Yet sometimes heat will disappear without leaving a single clue.

### Ice vs Water For Cooling

Every once in a while in the old days, the iceman would forget to stop by to refill the icebox. Occasionally, as the last sliver of ice melted away, somebody would come up with a bright idea. He would remember that the water in the drainpan always felt icelcold when he emptied it other times. So, he would get the thermometer out and check its temperature. Sure enough, it usually was about as cold as the ice. Why not put the drainpan back in the ice compartment to keep things cold until the iceman returned the next day?

For some strange reason, the icebox never stayed cold. The drain water soon got quite warm and in a couple of hours, the butter in the icebox would begin to melt, the milk would start to sour, and the vegetables would wilt.

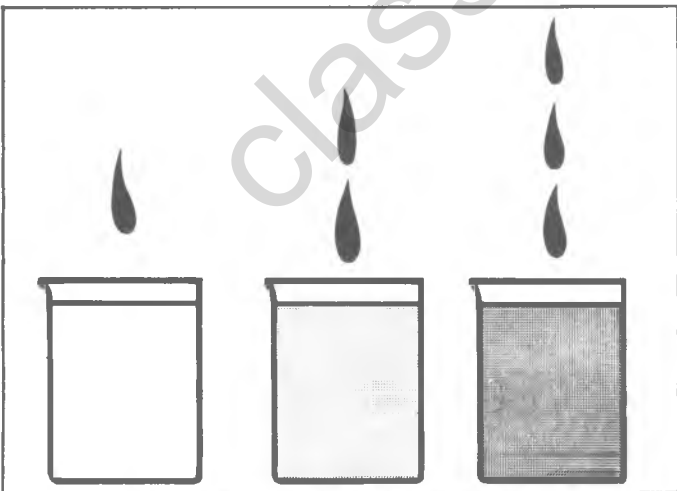

Fig. 25-Addition of B.T.U.'s Heats Water

The drain water was only a few degrees warmer than the ice yet it didn't draw nearly as much heat out of the stored foods. The difference between the behavior of cold drain water and ice is the real secret as to how any refrigerator works, and we can easily see this by using an ordinary thermometer.

When we put a drainpan full of cold water into the ice compartment, we expect the heat to flow from the warm foods to the colder water. Remember, that heat always flows from a warm object to a colder object and when we add heat to water, it gets warmer. Each B.T.U. of heat added to a pound of water makes it one degree warmer.

If we were to put a thermometer in the cold drain water, we would see the temperature gradually creep upwards. That is to be expected because heat is flowing into the cold water making it warmer. Before long the water would be as warm as the stored foods. Then the water could no longer attract heat because heat will not flow from one warm object to another equally warm object. Since we no longer can draw heat out of the foods we no longer are cooling them.

Now, let's see what happens when we put ice instead of cold water into the icebox. This time, we'll set the thermometer on top of the ice (fig. 26). When we first look at the thermometer, it reads 32°. A couple of hours later, the ice chunk is smaller because some of the ice has already melted away--but the thermometer still reads 32°.

All this time, the ice has been soaking up heat, yet it never gets any warmer no matter how much heat it draws from the stored food. On the other hand, the cold drain water got progressively warmer as it soaked up heat. The addition of heat will make water warmer yet won't raise the temperature of ice above the 32° mark.

If we fill one drinking glass with ice and another with cold water, and put both glasses in the same room where they could absorb equal amounts of heat from the room air, we will find it takes much, much longer for the ice to melt and reach room temperature than it did for the

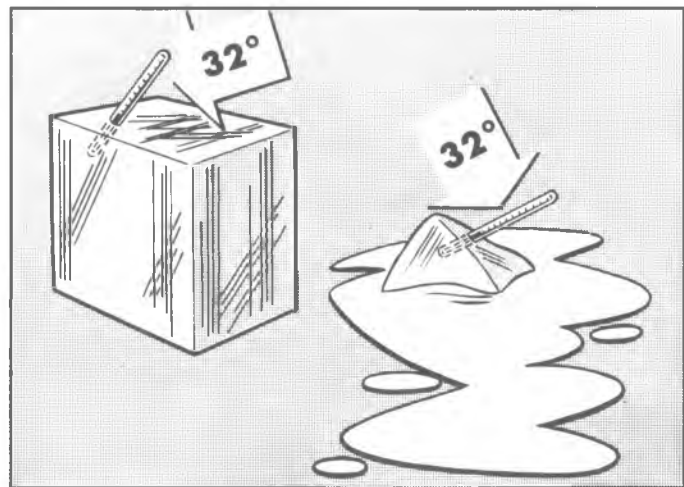

Fig. 26-Melting Ice Remains at 32°



water in the other glass to reach the same temperature. Obviously, most of the heat was being used to melt the ice. But it was the heat that apparently disappeared or was transformed because it couldn't be located with a thermometer. To describe this disappearing heat, scientists chose the word "latent" which means hidden.

### Latent Heat

So latent heat is nothing more nor less than hidden heat which can't be found with a thermometer.

At first it was thought that latent heat was in the water that melted from the ice. But that wasn't exactly the right answer because, upon checking water temperature as it melts from ice, it will be found that it is only a shade warmer than the ice itself. It is not nearly warm enough to account for all the heat the ice had absorbed. The only possible answer is that the latent heat had been used up to change the ice from a solid into a liquid.

Many substances can be either a solid, or a liquid, or a gas. It just depends on the temperature whether water for example was a liquid, or a solid (ice), or gas (steam) (fig. 27).

All solids soak up huge amounts of heat without getting any warmer when they change into liquids, and the same thing will happen when a substance changes from a liquid into a gas.

Put some water in a teakettle, set it over a fire and watch the thermometer as the water gets hotter and hotter, the mercury will keep rising until the water starts to boil. Then the mercury seems to stick at the  $212^{\circ}$  mark. Put more wood on the fire, despite all the increased heat, the mercury will not budge above the  $212^{\circ}$  mark (fig. 28).

No matter how large or hot you make the flame, you can't make water any hotter than  $212^{\circ}$  at sea level. As a liquid changes into a gas, it absorbs abnormally great amounts of heat without getting any hotter.

Now we have two different kinds of latent heat, which are quite a bit alike. To keep their identities separate,

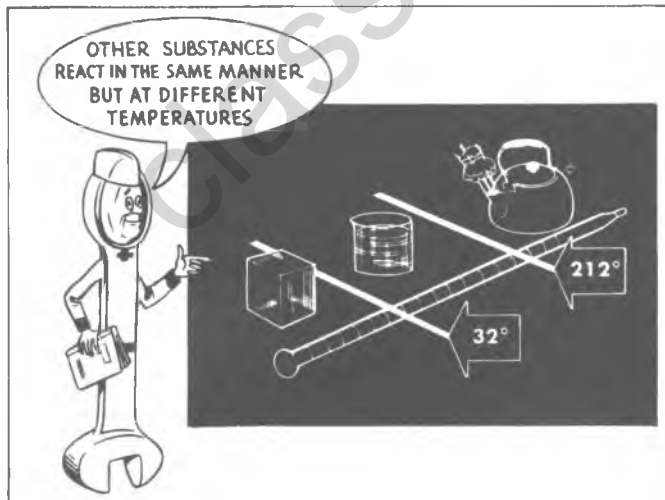

Fig. 27--Temperature Determines The State Of Water

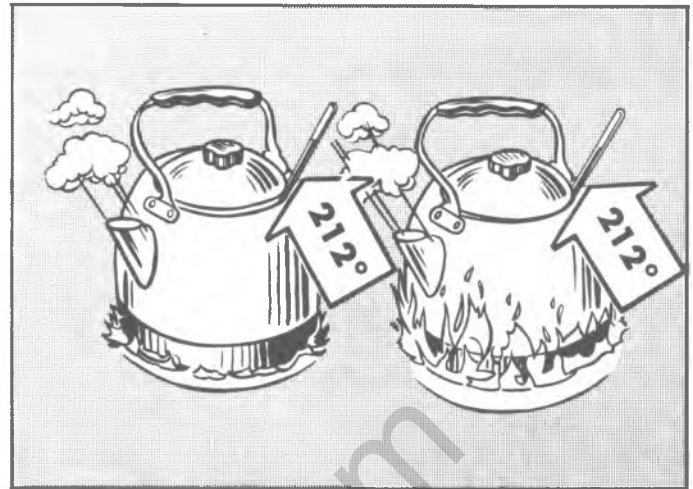

Fig. 28--Boiling Water Never Exceeds  $212^{\circ}$  at Sea Level

the first one is called **latent heat of fusion**, which means the same as melting. The other kind is called **latent heat of vaporization** because that means the same as evaporation.

### Refrigeration

It may seem as though we have discussed heat instead of refrigeration. But in doing so, we have learned how a simple icebox works. It's because the latent heat of fusion gives ice the ability to soak up quantities of heat without getting any warmer. Since it stays cold, it can continue to draw heat away from stored foods and make them cooler.

The latent heat of vaporization can be even better because it will soak up even more heat.

Whenever we think of anything boiling, we think of it being pretty hot, but that's not true in every case. Just because water boils at  $212^{\circ}$  doesn't mean that all other substances will boil at the same temperature. Some would have to be put into a blast furnace to make them bubble and give off vapor. On the other hand, others will boil violently while sitting on a cake of ice.

And so each substance has its own particular boiling point temperature. But regardless of whether it is high or low, they all absorb unusually large quantities of heat without getting any warmer when they change from a liquid into a vapor.

Consequently, any liquid that will boil at a temperature below the freezing point of water, will make ice cubes and keep vegetables cool in a mechanical refrigerator.

### REFRIGERANTS

The substance that carries heat out of a refrigerator cabinet is the refrigerant.

There are many refrigerants known to man. In fact, any liquid that can boil at temperatures somewhere near the freezing point of water can be used.

But a boiling point below the temperature at which ice forms is not the only thing that makes a good refrigerant. A refrigerant should also be non-poisonous and non-explosive to be safe. Besides that, we want a refrigerant that is non-corrosive and one that will mix with oil.

Chemists tried to improve existing natural refrigerants. But after exploring along that line, they still hadn't succeeded. They started from scratch and juggled molecules around to make an entirely new refrigerant. Eventually they succeeded by remodeling the molecules in carbon tetrachloride. This is the same fluid that is used in fire extinguishers and dry-cleaners' solvents.

From this fluid, the chemists removed two chlorine atoms and replaced them with two fluorine atoms. This newly formed fluid carried the technical chemical name of dichlorodifluoromethane. Today, it is sold commercially by manufacturers as Refrigerant-12 or R-12.

Flourine is a temperamental substance, under most conditions, it is toxic and highly corrosive. After it is manufactured, it has to be stored in special containers because it will eat through glass and will dissolve most metals in short order.

Despite its rambunctious character though, fluorine is completely tamed when it is combined with the other substances that go to make up the refrigerant. Each is non-toxic, non-inflammatory, non-explosive, and non-poisonous, however, breathing large quantities of R-12 should be avoided.

### Refrigerant-12

Refrigerant-12, which we use in Air Conditioning Systems, **boils** at  $21.7^{\circ}$  below zero. Picture a flask of R-12 sitting on the North Pole boiling away just like a teakettle on a stove. No one would dare pick up the flask with his bare hands because, even though boiling, it would be so cold and it would be drawing heat away from nearby objects so fast that human flesh would freeze in a very short time.

If we were to put a flask of R-12 inside a refrigerator cabinet, it would boil and draw heat away from everything surrounding it (fig. 29). So long as any refrigerant remained in the flask, it would keep on soaking up heat until the temperature got clear down to  $21.7^{\circ}$  below zero.

Now we can begin to see the similarity between a boiling teakettle and a refrigerator. Ordinarily we think of the flame pushing heat into the teakettle. Yet, it is just as logical to turn our thinking around and picture the teakettle pulling heat out of the flame. Both the teakettle and the flask of refrigerant do the same thing--they both draw in heat to boil although they do so at different temperature levels.

There also is another similarity between the icebox and the mechanical refrigerator. In the icebox, water from melting ice literally carried heat out of the cabinet. In our simple refrigerator, rising vapors do the same job.

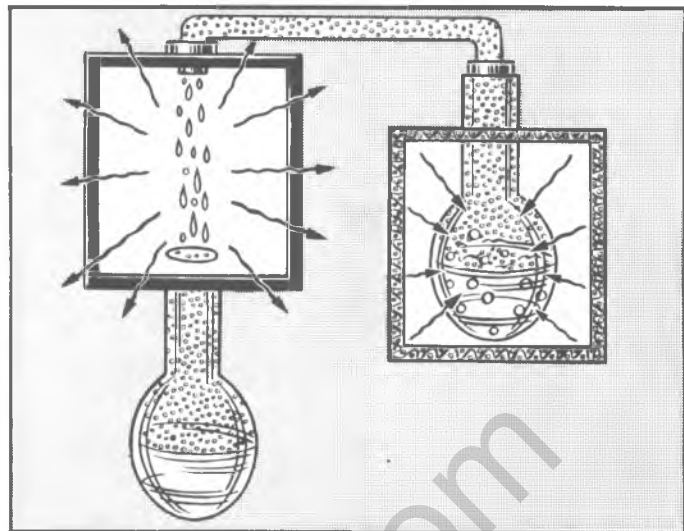

Fig. 29--A Simple R-12 Refrigerator

### Reusing R-12

R-12, or any other refrigerant, is too expensive just to let float away into the Atmosphere. If there was some way to remove the heat from the vapor and change it back into a liquid, it could be returned to the flask and used over again (fig. 30).

That is where we find the biggest difference between the old icebox and the modern refrigerator. We used to put in new ice to replace that lost by melting. Now we use the same refrigerant over and over again.

We can change a vapor back into a liquid by chilling it, or do the same thing with pressure. When we condense a vapor we will find that the heat removed just exactly equals the amount of heat that was necessary to make the substance vaporize in the first place.

This is called the latent heat of vaporization - the heat that apparently disappeared when a liquid boiled into a vapor--again reappears - when that same vapor reverts back into a liquid. It is just like putting air into a balloon

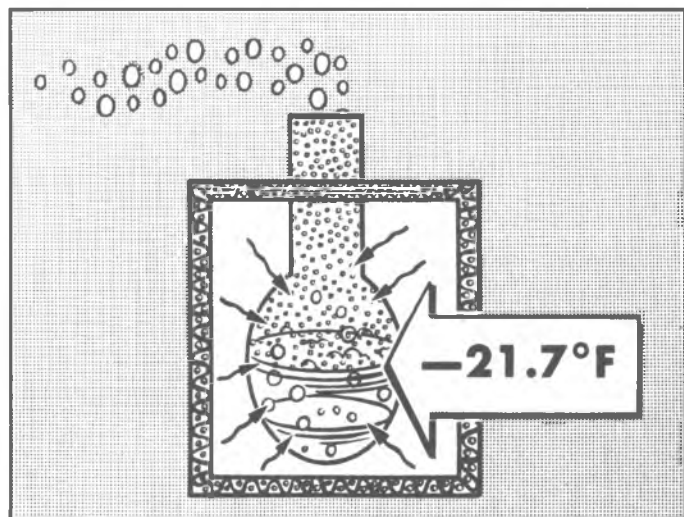

Fig. 30--Reusing Refrigerant

to expand it and then letting the same amount of air out again to return the balloon to its original condition.

We know that any substance will condense at the same temperature at which it boiled. This temperature point is a clear-cut division like a fence. On one side, a substance is a liquid. Immediately on the other side it is a vapor. Whichever way a substance would go, from hot to cold or cold to hot, it will change its character the moment it crosses over the fence.

Water will boil at 212° under normal conditions. Naturally, we expect steam to condense at the same temperature. But whenever we put pressure on steam, it doesn't. It will condense at some temperature higher than 212°. The greater the pressure, the higher the boiling point and the temperature at which a vapor will condense. This is the reason why pressure cookers cook food faster, since the pressure on the water permits it to boil out at a higher temperature.

We know that R-12 boils at 21.7° below zero. A thermometer will show us that the rising vapors, even though they have soaked up lots of heat, are only slightly warmer. But the vapors must be made warmer than the room air if we expect heat to flow out of them. The condensing point temperature must be above that of room air or else the vapors won't condense.

This is where pressure helps, with pressure, we can compress the vapor, thereby concentrating the heat it contains. When we concentrate heat in a vapor that way, we increase the intensity of the heat or, we increase the temperature, because temperature is merely a measurement of heat intensity (fig. 31).

### Pressure in Refrigeration

Because we must use pressures and gauges in air conditioning service, the following points are mentioned so that we will all be talking about the same thing when we speak of pressures.

All pressure, regardless of how it is produced, is measured in pounds per square inch (psi).

Atmospheric Pressure is pressure exerted in every direction by the weight of the atmosphere. At sea level atmospheric pressure is 14.7 psi. At higher altitudes air has less weight (lower psi).

Any pressure less than atmospheric (14.7) is known as a partial vacuum or commonly called a vacuum. A perfect vacuum or region of no pressure has never been mechanically produced.

Gauge pressure is used in refrigeration work. Gauges are calibrated in pounds (psi) of pressure and inches of Mercury for vacuum. At sea level, "0" lbs. gauge pressure is equivalent to 14.7 lbs. atmospheric pressure. Pressure greater than atmospheric is measured in pounds (psi) and pressure below atmospheric is measured in inches of vacuum. The "0" on the gauge will always correspond to the surrounding atmospheric pressure, regardless of the elevation where the gauge is being used.

### Pressure-Temperature Relationships of R-12

A definite pressure and temperature relationship exists in the case of liquid refrigerants and their saturated vapors. Increasing the temperature of a substance causes it to expand. When the substance is confined in a closed container, the increase in temperature will be accompanied by an increase in pressure, even though no mechanical device was used. For every temperature, there will be a corresponding pressure within the container of refrigerant. A table of the temperature-pressure relationship of R-12 is presented below. Pressures are indicated in gauge pressure, either positive pressure (above atmospheric) in pounds or negative pressure (below atmospheric) in inches of vacuum.

Thus if a gauge is attached to a container of R-12 and the room temperature is 70°, the gauge will register approximately 70 psi pressure; in a 100° room, the pressure would be 117 psi.

### Pressure and Flow

When we use a tire pump to inflate an automobile tire, we are creating pressure only because we are "pushing" against the air already entrapped inside the tire. If a tire has a puncture in it, you could pump all day, and still not be able to build up any pressure. As fast as you would pump the air in, it would leak out through the puncture. Unless you have something to push against--to block the flow of air--you can't create more than a mere semblance of pressure.

The same situation holds true in an air conditioning system. The compressor can pump refrigerant vapor through the system, but unless it has something to push against, it cannot build up pressure. All the compressor

°F	Pressure (psi)	°F	Pressure (psi)
- 40	11.0*	+ 50	46.7
- 35	8.3*	+ 55	52.0
- 30	5.5*	+ 60	57.7
- 25	2.3*	+ 65	63.7
- 20	0.6	+ 70	70.1
- 15	2.4	+ 75	76.9
- 10	4.5	+ 80	84.1
- 5	6.8	+ 85	91.7
0	9.2	+ 90	99.6
+ 5	11.8	+ 95	108.1
+10	14.7	+100	116.9
+15	17.7	+105	126.2
+20	21.1	+110	136.0
+25	24.6	+115	146.5
+30	28.5	+120	157.1
+32	30.1	+125	167.5
+35	32.6	+130	179.0
+40	37.0	+140	204.5
+45	41.7	+150	232.0

\* Inches of Vacuum

would be doing would be to circulate the vapor without increasing its pressure.

We can't just block the flow through the system entirely. All we want to do is put pressure on the refrigerant vapor so it will condense at normal temperatures. This must be done sometime after the vapor leaves the evaporator and before it returns again as a liquid. High pressure in the evaporator would slow down the boiling of the refrigerant and penalize the refrigerating effect.

### Controlling Pressure and Flow

Pressure and flow can be controlled with a float valve, or with a pressure-regulating valve.

The float valve type will give us a better idea of pressure and flow control, let's look at it first.

It consists simply of a float that rides on the surface of the liquid refrigerant. As the refrigerant liquid boils and passes off as a vapor, naturally the liquid level drops lower and lower. Correspondingly, the float, because it rides on the surface of the refrigerant, also drops lower and lower as the liquid goes down.

By means of a simple system of mechanical linkage, the downward movement of the float opens a valve to let refrigerant in. The incoming liquid raises the fluid level and, of course, the float rides up along with it. When the surface level of the refrigerant liquid reaches a desired height, the float will have risen far enough to close the valve and stop the flow of refrigerant liquid.

We have described the float and valve action as being in a sort of definite wide open or tight shut condition. Actually, the liquid level falls rather slowly as the refrigerant boils away. The float goes down gradually and gradually opens the valve just a crack. At such a slow rate of flow, it raises the liquid level in the evaporator very slowly.

It is easy to see how it would be possible for a stabilized condition to exist. By that, we mean a condition wherein the valve would be opened enough to allow just exactly the right amount of refrigerant liquid to enter the system to take the place of that leaving as a vapor.

### Refrigerator Operation

We've now covered all the scientific ground-rules that apply to refrigeration. Try to remember these main points. All liquids soak up lots of heat without getting any warmer when they boil into a vapor, and, we can use pressure to make the vapor condense back into a liquid so it can be used over again. With just that amount of scientific knowledge, here is how we can build a refrigerator.

We can place a flask of refrigerant in an icebox. We know it will boil at a very cold temperature and will draw heat away from everything inside the cabinet (fig. 31).

We can pipe the rising vapors outside the cabinet and thus provide a way for carrying the heat out. Once we get the heat-laden vapor outside, we can compress it with

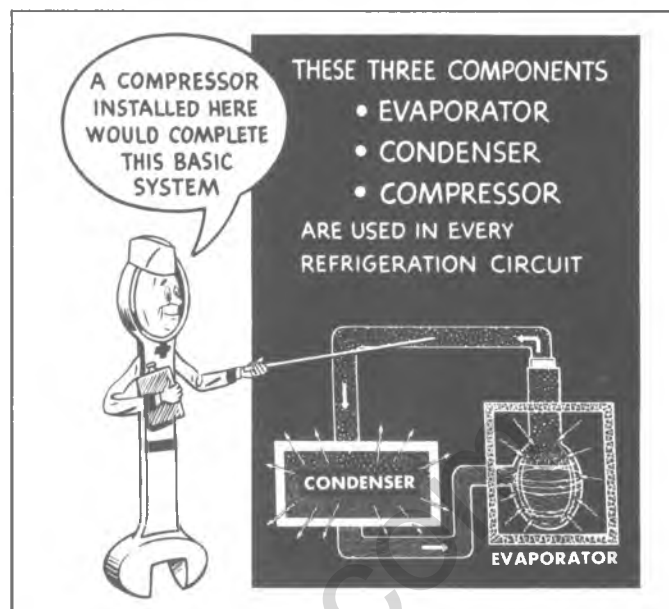

Fig. 31--Basic Refrigerant Circuit

a pump. With enough pressure, we can squeeze the heat out of "cold" vapor even in a warm room. An ordinary radiator will help us get rid of heat.

By removing the heat, and making the refrigerant into a liquid, it becomes the same as it was before. So, we can run another pipe back into the cabinet and return the refrigerant to the flask to be used over again.

That is the way most mechanical refrigerators work today. Now, let's look at air conditioning to see the benefits of air conditioning and how an air conditioner works.

### AIR CONDITIONING

Because air-conditioning has always been very closely allied with mechanical refrigeration, most of us are apt to think of it only as a process for cooling room air.

Air Conditioning goes beyond the mere cooling of the air. It controls the humidity, cleanliness and circulation of the air.

Whenever it gets warm and muggy in the summertime, someone is almost sure to say, "It's not the heat...it's the humidity." But that is only partly right. Actually it is a combination of the two that makes us feel so warm...temperature alone is not the only thing that makes us uncomfortable.

Humidity is the moisture content of the air. To a certain extent, it is tied in with the temperature of the air. Warm air will hold more moisture than will cold air. When air contains all the moisture it can hold, it is saturated, and the relative humidity is 100%. If the air contains only half as much water as it could hold at any given temperature, we say that the relative humidity is 50%. If it contains only a fifth of its maximum capacity, we say that the relative humidity is 20%. This amount of water

vapor, or relative humidity, affects the way we perspire on hot days.

Nature has equipped our bodies with a network of sweat glands that carry perspiration to the skin surfaces. Normally, this perspiration evaporates and absorbs heat just like a refrigerant absorbs heat when it is vaporized in a freezer. Most of the heat is drawn from our bodies, giving us a sensation of coolness. A drop of alcohol on the back of your hand will demonstrate this principle convincingly. Alcohol is highly volatile, and will evaporate very rapidly and absorb quite a bit of heat in doing so, making the spot on your hand feel cool.

The ease and rapidity with which evaporation takes place, whether it be alcohol or perspiration, governs our sensation of coolness and to a certain extent, independently of the temperature. The ease and rapidity of the evaporation are directly affected by the relative humidity or comparative dampness of the air. When the air is dry, perspiration will evaporate quite readily. But when the air contains a lot of moisture, perspiration will evaporate more slowly; consequently less heat is carried away from our body.

From the standpoint of comfort, air-conditioning should control the relative humidity of the air as well as its temperature.

By reducing the humidity, we oftentimes can be just as "cool" in a higher room temperature than otherwise would be comfortable. Laboratory tests have shown that the average person will feel just as cool in a temperature of 79° when the relative humidity is down around 30% as he will in a cooler temperature of 72° with a high relative humidity of 90%.

There are practical limits though within which we must stay when it comes to juggling humidity. For comfort, we can't go much below a relative humidity of 30% because anything lower than that would cause an unpleasant and unhealthy dryness in the throat and nasal passages.

Summertime temperatures of 85° sometimes bring with them relative humidities around 75% to 80%. To gain maximum human comfort, an air conditioning system should cool the air down and reduce the humidity to comfortable limits.

Along with the cooling job it does, the evaporator unit also removes much of the moisture from the air. Everyone is familiar with the sight of thick frost on the freezer of a refrigerator. That frost is simply frozen moisture that has come out of the air.

The evaporator unit as an air conditioning system does the same thing with this one exception. Because its temperature is above the freezing point, the moisture does not collect in the form of ice or frost. The moisture remains fluid and drips off the chilling unit. A further advantage of air conditioning is that dust and pollen particles are trapped by the wet surfaces of the evaporator core and then drained off along with the condensed moisture. This provides very clean, pure air for breathing.

## BASIC AIR CONDITIONER

When we look at an air conditioning unit, we will always find a set of coils or a finned radiator core through which the air to be cooled passes. This is known as the "evaporator". It does the same job as the flask of refrigerant we spoke about previously. The refrigerant boils in the evaporator. In boiling, of course, the refrigerant absorbs heat and changes into a vapor. By piping this vapor outside the car we can bodily carry out the heat that caused its creation.

Once we get vapor out of the evaporator, all we have to do is remove the heat it contains. Since heat is the only thing that expanded the refrigerant from a liquid to a vapor in the first place, removal of that same heat will let the vapor condense into a liquid again. Then we can return the liquid refrigerant to the evaporator to be used over again.

Actually, the vapor coming out of the evaporator is very cold. We know the liquid refrigerant boils at temperatures considerably below freezing and that the vapors arising from it are only a shade warmer even though they do contain quantities of heat. Consequently, we can't expect to remove heat from sub-freezing vapors by "cooling" them in air temperatures that usually range between 60° and 100°...heat refuses to flow from a cold object toward a warmer object.

But with a pump, we can squeeze the heat-laden vapor into a smaller space. And, when we compress the vapor, we also concentrate the heat it contains. In this way, we can make the vapor hotter without adding any heat. Then we can cool it in comparatively warm air.

That is the only responsibility of a compressor in an air conditioning system. It is not intended to be a pump just for circulating the refrigerant. Rather, its job is to exert pressure for two reasons. Pressure makes the vapor hot enough to cool off in warm air. At the same time, the compressor raises the refrigerant's pressure above the condensing point at the temperature of the surrounding air so it will condense.

As the refrigerant leaves the compressor, it is still a vapor although it is now quite hot and ready to give up the heat that it absorbed in the evaporator. One of the easiest ways to help refrigerant vapor discharge its heat is to send it through a radiator-like component known as a condenser.

The condenser really is a very simple device having no moving parts. It does exactly the same job as the familiar radiator in a typical home steam-heating system. There, the steam is nothing more than water vapor. In passing through the radiator, the steam gives up its heat and condenses back into water.

The purpose of the condenser, as the name implies, is to condense the high pressure, high temperature refrigerant vapor discharged by the compressor into a high pressure liquid refrigerant. This occurs when the high pressure, high temperature refrigerant is subjected to the

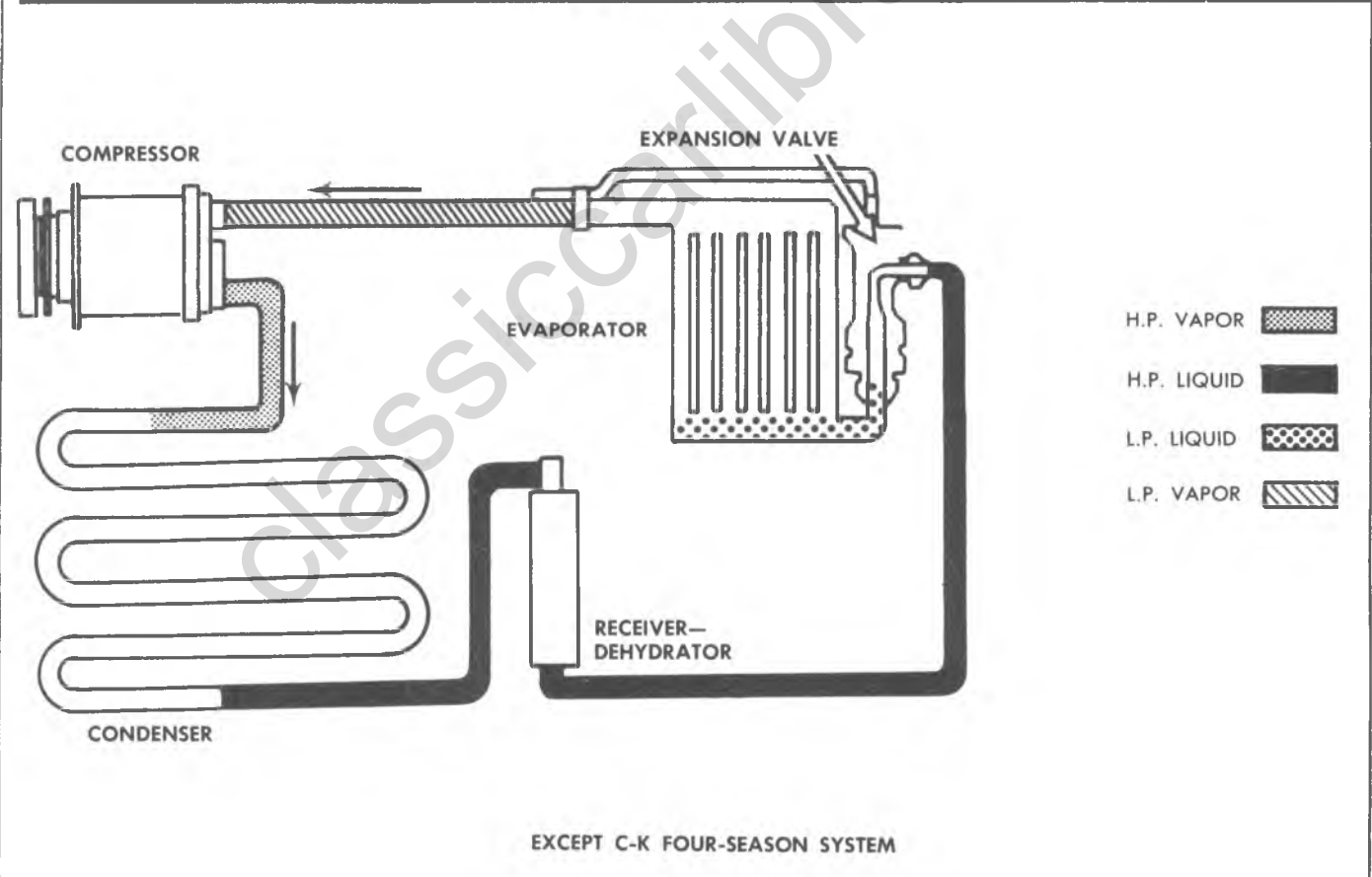
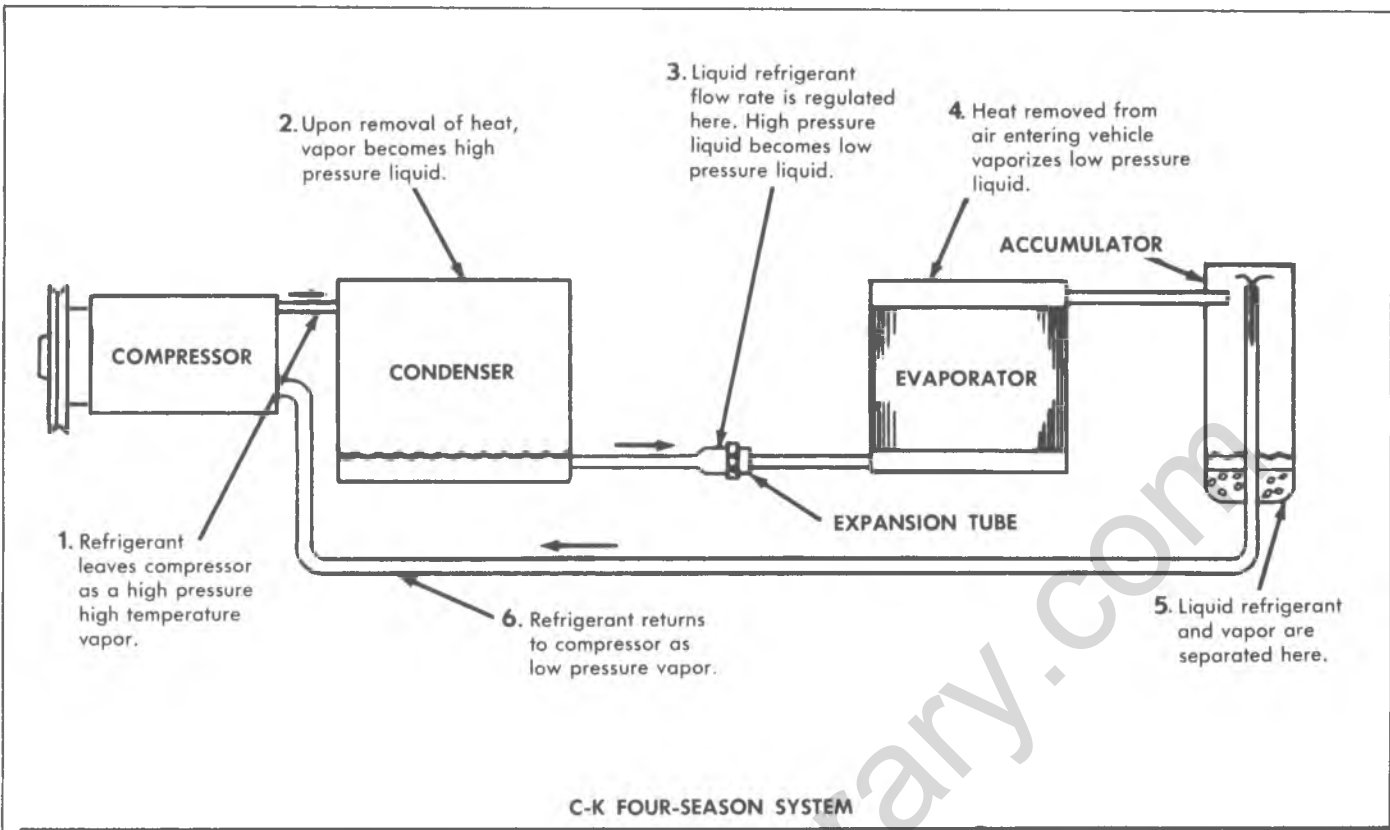

Fig. 32--Basic Refrigeration Cycle

considerably cooler metal surfaces of the condenser. This is due to the fundamental laws, covered earlier, which state that "heat travels from the warmer to the cooler surface," and that "when heat is removed from vapor, liquid is produced."

When the refrigerant condenses into a liquid, it again is ready for boiling in the evaporator. So, we run a pipe from the condenser back to the evaporator.

## MAIN UNITS OF THE SYSTEM

These three units then; the evaporator, the compressor, and the condenser...are the main working parts in any typical air conditioning system. We have the evaporator where the refrigerant boils and changes into a vapor, absorbing heat as it does so. We have the pump or compressor to put pressure on the refrigerant so it can get rid of its heat. And we have a condenser outside the car body to help discharge the heat into the surrounding air.

Now let's look at the compressor in detail, and some of the components that work with these main units to complete the air conditioning system.

### Compressor

The prime purpose of the compressor (fig. 33) is to take the low pressure refrigerant vapor produced by the evaporator and compress it into a high pressure, high temperature vapor which will be sent on to the condenser.

It utilizes the principle that "when a vapor is compressed, both its pressure and temperature are raised" which we have already discussed. The compressor is mounted above the engine in a special rubber mounted bracket and is belt driven from the engine through an electromagnetic clutch pulley on the compressor.

The compressor has three double-acting pistons, making it a six cylinder compressor. The compressor has a 1.5 inch bore and 1.1875 inch stroke, giving it a total displacement of 12.6 cu. in. Identification of the compressor is by model and serial number stamped on a plate on top of the compressor.

### Clutch-Pulley

The movable part of the clutch drive plate is in front of the pulley and bearing assembly. The armature plate, the movable member, is attached to the drive hub through driver springs and is riveted to both members. The hub of the drive plate is pressed over a square drive key located in the compressor shaft. A spacer and retainer ring are assembled to the shaft and the assembly is held in place with a self-locking nut. The pulley rim, power element ring and pulley hub are formed into a final assembly by molding a frictional material between the rim and the hub with the power element ring imbedded in the forward face of the assembly.

A two-row ball bearing is pressed into the pulley hub

and held in place by a retainer ring. The entire pulley and bearing assembly is then pressed over the front head of the compressor and secured by a retainer ring.

### Clutch Coil

The coil is molded into the coil housing with a filled epoxy resin and must be replaced as a complete assembly. Three protrusions on the rear of the housing fit into alignment holes in the compressor front head. A retainer ring secures the coil and housing in place. The coil has 3.85 ohms resistance at 80°F. ambient temperature and will require no more than 3.2 amperes at 12 volts D.C. Since the clutch coil is not grounded internally, a ground lead is required as well as a "hot" lead.

### Shaft Seal

The main shaft seal, located in the neck of the compressor front head, consists of the seal assembly with its ceramic seal face in a spring loaded cage. An "O" ring seal, located within the ceramic seal, provides a seal to the shaft surface. The contact surface of the shaft seal seat is finished to a high polish and must be protected against nicks, scratches and even fingerprints. Any surface damage will cause a poor seal. An "O" ring, located in an internal groove in the neck of the front head provides a seal with the outer diameter of the seal seat. A retainer ring, tapered side away from the seat, secures the seat in place. The hub and armature plate must be removed to gain access to the seal. A shaft seal kit contains all necessary replacement parts for field service.

After removing the clutch drive, pulley-bearing and coil housing assemblies, the rear head and internal mechanism (fig. 33) may be removed from the compressor shell. Four threaded studs, welded to the compressor shell, locate the rear head and four lock nuts secure it in place.

### Rear Head

The rear head (fig. 34) has a machined cavity in the center for the oil pump gears. This cavity, in all compressors, is machined so that the eccentricity of the bore is approximately .042 inch to the LEFT of the centerline of the cavity. The counterclockwise rotation compressor used in some other systems has the eccentricity machined approximately .042 inch to the RIGHT of the cavity centerline. A small diameter hole is drilled in the head between the two. The unit number is stamped on a plate attached to the counterclockwise rotation head and a decal arrow indicates the direction of rotation.

### Mainshaft

The central mainshaft, driven by the clutch-pulley when the coil is energized, extends through the front head to the rear head and oil pump cavity of the compressor. The shaft revolves in needle roller bearings located in the front and rear halves of the cylinder assembly. A 3/16" internally drilled passage extends through the

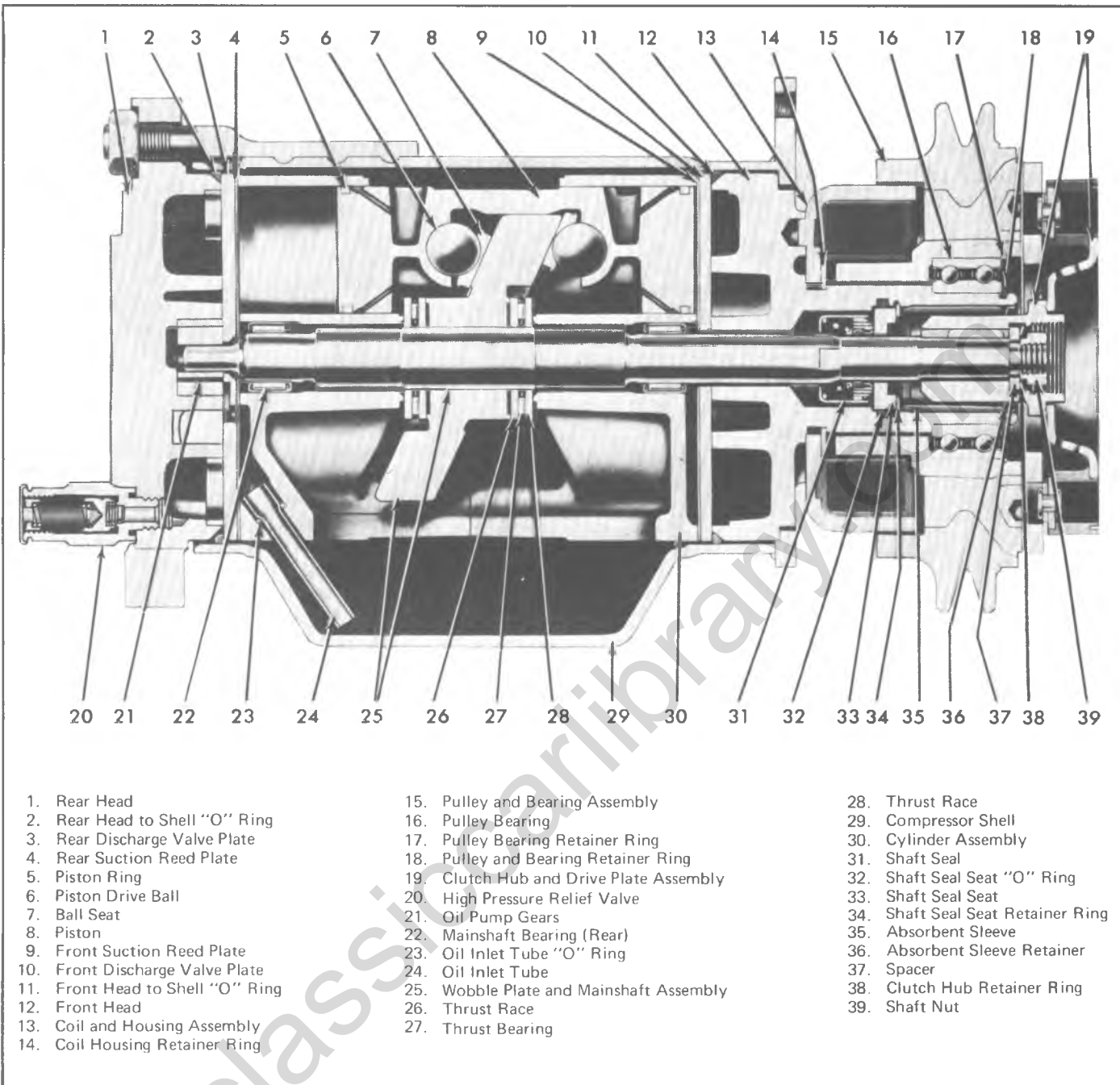

- |                                  |   |                                   |
|----------------------------------|---|-----------------------------------|
| 1. Rear Head                     | 15. Pulley and Bearing Assembly         | 28. Thrust Race                   |
| 2. Rear Head to Shell "O" Ring   | 16. Pulley Bearing                      | 29. Compressor Shell              |
| 3. Rear Discharge Valve Plate    | 17. Pulley Bearing Retainer Ring        | 30. Cylinder Assembly             |
| 4. Rear Suction Reed Plate       | 18. Pulley and Bearing Retainer Ring    | 31. Shaft Seal                    |
| 5. Piston Ring                   | 19. Clutch Hub and Drive Plate Assembly | 32. Shaft Seal Seat "O" Ring      |
| 6. Piston Drive Ball             | 20. High Pressure Relief Valve          | 33. Shaft Seal Seat               |
| 7. Ball Seat                     | 21. Oil Pump Gears                      | 34. Shaft Seal Seat Retainer Ring |
| 8. Piston                        | 22. Mainshaft Bearing (Rear)            | 35. Absorbent Sleeve              |
| 9. Front Suction Reed Plate      | 23. Oil Inlet Tube "O" Ring             | 36. Absorbent Sleeve Retainer     |
| 10. Front Discharge Valve Plate  | 24. Oil Inlet Tube                      | 37. Spacer                        |
| 11. Front Head to Shell "O" Ring | 25. Wobble Plate and Mainshaft Assembly | 38. Clutch Hub Retainer Ring      |
| 12. Front Head                   | 26. Thrust Race                         | 39. Shaft Nut                     |
| 13. Coil and Housing Assembly    | 27. Thrust Bearing                      |                                   |
| 14. Coil Housing Retainer Ring   |   |                                   |

Fig. 33-Six Cylinder Compressor--Cross Sectional View

shaft from the rear oil pump cavity to the shaft seal cavity in the front compressor head. Four .078 inch holes, drilled at 90° to the main passage, direct oil under pump pressure to the shaft seal surfaces, thrust bearings and shaft-cylinder bearings.

**Wobble Plate**

The wobble plate is an angular shaped member pressed onto the mainshaft forming the mainshaft and wobble plate assembly (fig. 34). A woodruff key prevents movement of the plate around the shaft. Location of the plate on the shaft is factory set and must not be changed.

The very smooth angular faces of the plate are ground to be parallel within .0003 inches of each other. The plate changes the rotating action of the shaft into the reciprocating driving force for three pistons. The driving force is applied, through the drive balls and ball seats (shoe discs) to the midpoint of each of the double end pistons.

**Cylinder Block**

The cylinder block consists of a front and a rear half. Three piston bores are line bored in each half during production to assure proper alignment and parallelism.



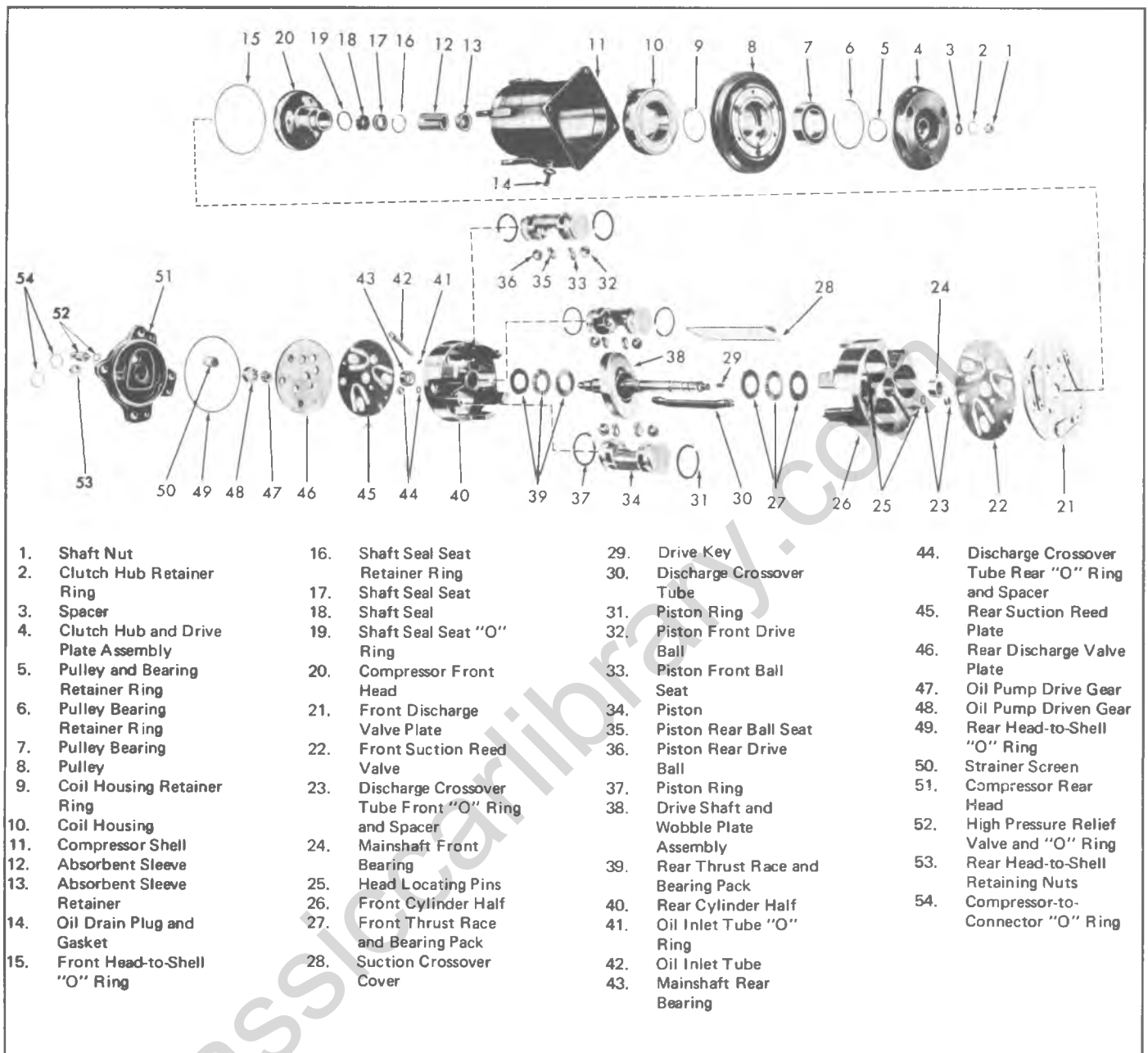

Fig. 34-Six Cylinder Compressor-Exploded View

The two halves must be serviced as an assembly to assure correct relationship of parts.

### Pistons

The cast aluminum double end pistons (fig. 34), have grooves to receive piston rings. Each ring has an oil scraper groove which should face away from the piston face. Two oil return passages are drilled from each ring groove. A notch in the casting web of each piston identifies the end of the piston which should be positioned toward the front end of the compressor. A spherical cavity is located on both inner faces of each piston to receive the piston drive balls.

### Drive Balls

The hardened steel drive balls have a micro-finish. They

are manufactured to a .0001 inch spherical tolerance and a .6248 - .6250 inch diameter tolerance.

### Ball Seats

The bronze ball seats have one flat side, which contacts the wobble plate, and one concave surface into which the drive ball fits. Ten seats are provided in .0005 inch thickness variations including a basic ZERO seat for simple field gauging operations. Seats are marked with their size which corresponds to the last three digits of the piece part number.

Selection from this group must be made to provide .0050 inch to .0010 inch total clearance between the ball seats

## 1A-34 HEATER AND AIR CONDITIONING

and the wobble plate at the tightest place throughout its 360° rotation (fig. 35).

### Thrust Bearings

The thrust bearings, sandwiched between two thrust races (see below) are located between the shoulders of the wobble plate and the shoulders of both the front and rear cylinder hubs.

### Thrust Races

The steel thrust races are ground to fixed thicknesses. A total of 14 races in increments of .0005 inch thickness are available for field service. As in the case of the ball seats the thrust races will be identified on the part by their thickness, the number on the race corresponding to the last three digits of the piece part number. The FRONT combination of a race, bearing and race is selected to provide the proper head clearance between the top of the cylinder and the underside of the suction and discharge valve plates. The REAR end combination of bearing and races is selected to obtain .0005 inch low limit to .0015 inch high limit running clearance between the hub surfaces of the wobble plate and the front and rear hubs of the cylinder (fig. 35). This allows .001 inch tolerance between the high and low limits.

### Oil Pump Gears

The oil pump gears are made of sintered iron. The inner, or driver gear has a "D" shaped hole in the center which fits over a similar area on the rear of the mainshaft.

### Shell

The compressor shell has a mounting flange on the front

end and four threaded studs welded to the outside of the rear end. The oil sump is formed into the shell and a baffle plate is welded over the sump on the inside of the shell.

### Heads

Both front and rear heads have an irregular shaped casting web. These webs provide the necessary seals to the surfaces of the discharge plates and prevent high pressure vapor from flowing into the low pressure cavity.

### Suction Screen

A fine mesh inlet (or suction) screen is located in the low pressure cavity of the rear head. Its purpose is to stop any material which could damage the compressor mechanism.

### Suction Cross-Over Cover

The suction cross-over cover, with its neoprene seal is pressed into the dove-tail cavity in the front and rear cylinder castings to form a passage for the low pressure vapor to flow from the rear head of the compressor to the front head.

### Discharge Cross-Over Tube

Since the double acting pistons supply high pressure vapor at both ends of the compressor the discharge tube is needed to supply a path for the high pressure vapor to pass from the front to the rear head. Should the cylinder halves be separated during service operations a service type discharge tube must be substituted.

### Suction Reed Valves

A separate three-reed suction valve disc is assembled to both front and rear heads. These reeds open when the piston is on the intake portion of the stroke to allow the low pressure vapor to flow into the cylinder. When the piston reverses and begins the compression portion of its stroke the reed valves close against their seats, thus preventing the high pressure vapor from being forced back into the low side of the system.

### Discharge Valves

The two discharge valve plate assemblies act to direct high pressure vapor into the head castings. When the piston reverses into its suction stroke the high pressure on the opposite side of the plate causes the reeds to close thus maintaining the differential of pressure between high and low pressure areas. The discharge plates include the valves and the retainers which prevent the high pressure from distorting the valves during the pressure stroke of the piston.

### Head to Shell Seals

Two large diameter "O" rings internally seal the front and rear heads to the shell. A chamfered edge on the head castings creates a squeezing action between the discharge valve plates, the compressor, and the inside surface of the shell.

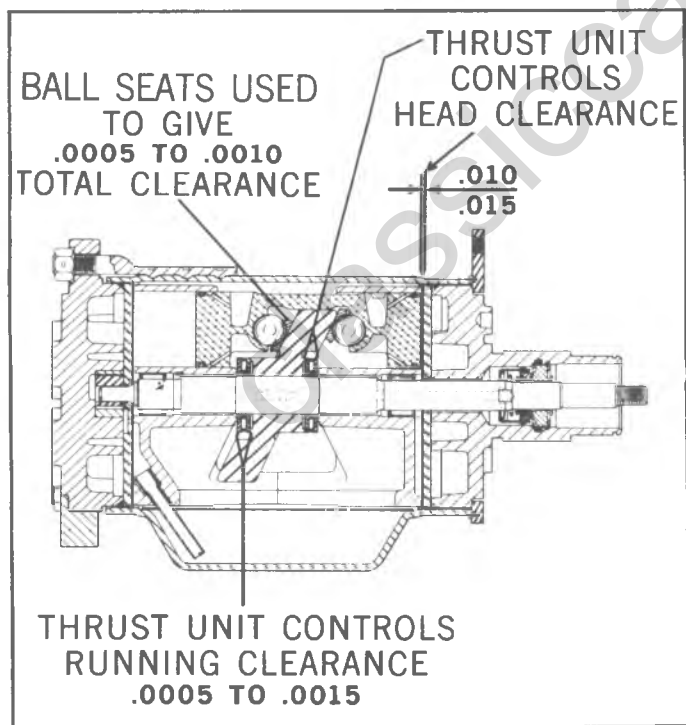

Fig. 35--General Running Clearances

### Compressor Connector

Compressor connectors, are attached to the compressor rear head by means of a single bolt and lock washer. All have inlet and outlet connections connected by a strap to form an integral unit.

G Models have gauge fittings located on the muffler and compressor inlet line. Motor Home Chassis unit fittings are located on the inlet and outlet lines. C-K model gauge fittings are located on the accumulator and evaporator inlet line. All fittings are equipped with a valve core.

### Pressure Relief Valve

The pressure relief valve, located on the compressor rear head, is simply a safety valve designed to open automatically if the system pressure should reach a pre-determined level high enough to cause system damage. After the pressure drops to a safe level the valve will close. After such an occurrence, the system should be thoroughly checked to discover and correct the cause of the abnormal pressure increase, and then should be purged, evacuated and charged.

### Refrigerant Lines

Special refrigerant hose lines are required to carry the refrigerant liquid and vapor between the various system components. The hose line with the smallest diameter is called the high pressure liquid line. It is routed from the condenser or receiver-dehydrator to the evaporator or thermostatic expansion valve. The large diameter hose line connecting the compressor and evaporator (or accumulator) is the low pressure vapor line. The small diameter hose between the compressor and condenser is the high pressure vapor discharge line.

These hoses are constructed with a synthetic material core covered by a woven fabric and coated for extra protection. This hose is so constructed to withstand the extreme pressures and temperatures found in the modern refrigeration system. **None but special refrigerant type hoses should be used.**

All systems make use of swaged type connections (hose to metal fittings) with metal to metal fittings being made using "O" rings. Care must be taken when making these connections that they not be turned down too tightly or damage to the "O" rings may result.

Flexible refrigerant hoses should not be permitted to contact the hot engine manifold nor should they be bent into a radius of less than 4 times their diameter.

### Muffler

A muffler, located in the high pressure line from the compressor to the condenser, serves as a surge chamber for high pressure gas to reduce the noise level of the system while in operation. The muffler is actually a welded portion of the compressor connector assembly. It is found on all truck air conditioning systems.

### Fan Slip Clutch

A special engine fan is used on most systems. It is a 19.5 inch six or seven bladed fan, limited by means of a viscous clutch to a maximum speed of 3400-3700 rpm, regardless of the speed of the engine. The silicone fluid in the clutch transmits only enough torque to drive the fan at this limited speed, thus avoiding excessive noise and power consumption by the fan at higher engine speeds.

### Condenser

In a properly charged system, the condenser delivers sub-cooled liquid. This is because all the vapor condenses before the end of the condenser and the remaining portion of the condenser subcools the liquid.

### Receiver-Dehydrator (G and Motor Home Chassis Models)

The receiver-dehydrator, serving as a reservoir for storage of high pressure liquid produced in the condenser, incorporates a screen sack filled with the dehydrating agent.

The receiver-dehydrator, used primarily as a liquid storage tank, also functions to trap minute quantities of moisture and foreign material which may have remained in the system after installation or service operations. A refrigerant sight glass is built into the receiver-dehydrator to be used as a quick check of the state and condition of charge of the entire system. The receiver-dehydrator is mounted near the condenser.

### Sight Glass (G and Motor Home Chassis Models)

While having no real function to perform in the system, the sight glass is a valuable aid in determining whether or not the refrigerant charge is sufficient and for eliminating some guess work in diagnosing difficulties. The sight glass, is built into the receiver-dehydrator outlet connection and is designed and located so that a shortage of refrigerant at this point will be indicated by the appearance of bubbles beneath the glass. The dust cap provided should be kept in place when the sight glass is not in use.

### Thermostatic Expansion Valve (Fig. 36)

C-K Overhead, G C60 and Overhead and Motor Home Chassis systems use a thermostatic expansion valve in place of a float system.

The valve consists primarily of the power element, body, actuating pins, seat and orifice. At the high pressure liquid inlet, is a fine mesh screen which prevents dirt, filings or other foreign matter from entering the valve orifice.

When the valve is connected in the system, high pressure liquid refrigerant enters the valve through the screen from the receiver-dehydrator or condenser and passes on to the seat and orifice. Upon passing through the orifice the high pressure liquid becomes low pressure liquid. The low pressure liquid leaves the valve and flows into

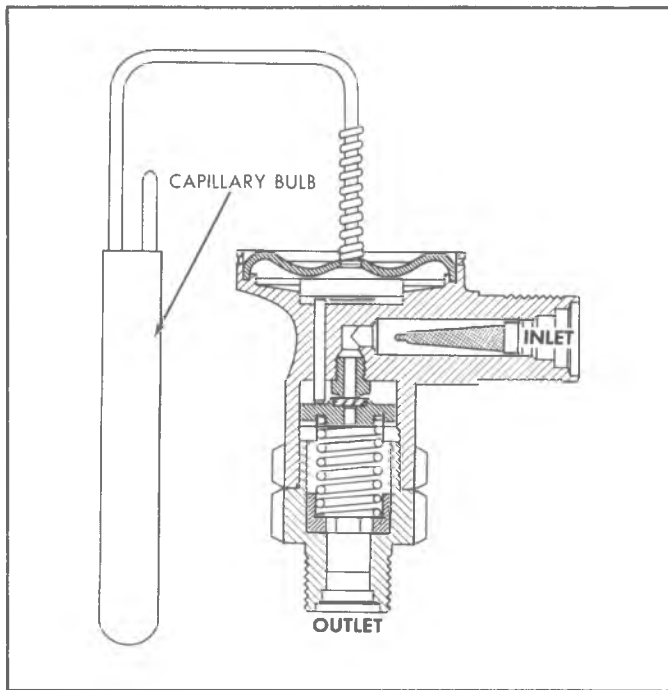

Fig. 36-Expansion Valve

the evaporator core where it absorbs heat from the evaporator core and changes to a low pressure vapor, and leaves the evaporator core as such. The power element bulb is clamped to the low pressure vapor line just beyond the outlet of the evaporator (fig. 36).

The operation of the valve is quite simple. It is a matter of controlling opposing forces produced by a spring and the refrigerant pressures. For example: The pressure in the power element is trying to push the seat away from the orifice, while the adjusting spring is trying to force the seat toward the orifice. These opposing pressures are established in the design of the valve so that during idle periods the adjusting spring tension and the refrigerant pressure in the cooling coil are always greater than the opposing pressure in the power element. Therefore, the valve remains closed. When the compressor is started, it will reduce the pressure and temperature of the refrigerant in the cooling coil to a point where the vapor pressure in the power element becomes the stronger. The seat then moves off the orifice and liquid starts to flow through the valve orifice into the cooling coil.

The purpose of the power element is to help determine the quantity of liquid that is being metered into the cooling coil. As the temperature of the low pressure line changes at the bulb, the pressure of the vapor in the power element changes, resulting in a change of the position of the seat. For example, if the cooling coil gets more liquid than is required, the temperature of the low pressure line is reduced and the resultant lowering of the bulb temperature reduces the pressure of the vapor in the power element, allowing the seat to move closer to the orifice. This immediately reduces the amount of liquid leaving the valve. Under normal operation, the

power element provides accurate control of the quantity of refrigerant to the cooling coil.

To employ our tire pump analogy once more for clarity, it is the same situation that would exist if you were inflating a tire with a very slow leak. Providing you pumped the air into the tire as fast as it leaked out, you would be able to maintain pressure even though the air would merely be circulating through the tire and leaking out through the puncture.

### Accumulator--C-K Models (Fig. 37)

The accumulator is located at the evaporator outlet. Its most important function is not to "accumulate" although this too is important. Its primary function is to separate liquid retained from vapor, retain the liquid and release the vapor to the compressor.

Thus, in an ideal accumulator with no oil bleed hole, and in a correctly designed system, no liquid can get to the compressor.

In an actual accumulator, there is some entrained liquid in the vapor stream to the compressor. The measure of a good accumulator is how well it separates vapor from liquid and how little entrained liquid is released to the compressor. Also, in an actual accumulator, an oil bleed

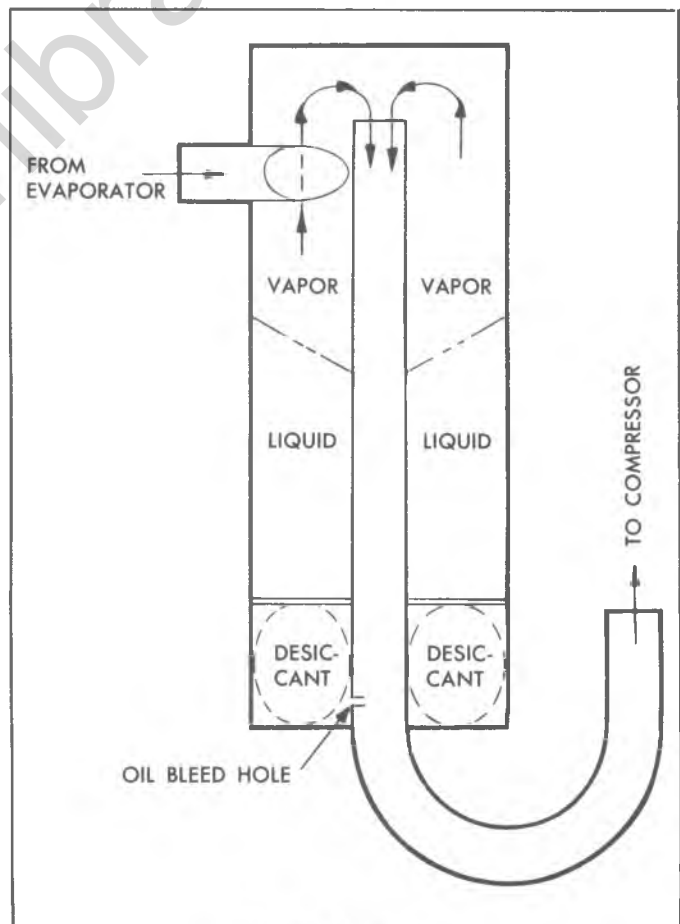

Fig. 37-Accumulator

hole is required to prevent trapping of oil in the bottom of the accumulator; this oil bleed hole bleeds some liquid refrigerant as well.

Therefore, flow out of the accumulator to the compressor consists mostly of vapor with the addition of entrained liquid and liquid flow through the oil bleed hole.

A bag of desiccant (dehydrating agent) is located in the base of the accumulator as a moisture collecting device.

NOTE: There is no sight glass in the accumulator clutch cycle system.

### Expansion Tube--C-K Models

Expansion tube flow rate depends on pressure difference and on subcooling; however, the flow rate is more sensitive to subcooling.

The expansion tube is located in the enlarged portion of the evaporator inlet line (fig. 38).

### Thermostatic Switch

System temperature is controlled by running the compressor intermittently, automatically turning it on and off as necessary to maintain proper temperatures. The compressor is started and stopped through the use of an electro-magnetic clutch and a thermostat affected by variations in temperature.

The thermostatic switch incorporates a metallic tube which contains a highly expansive gas. This tube is inserted into the evaporator core (C-K Four-Season System) or is located in the air stream as it leaves the evaporator (Motor Home Chassis Unit). The tube leads to a bellows operated switch. As air temperature rises, the gas inside the tube expands, travels through the tube to the bellows and closes the electrical switch which engages the compressor clutch.

As soon as the compressor starts running, the temperature begins to go down. As the air being cooled

gets colder, the gas in the thermostatic tube begins to reduce the pressure on the switch bellows. This allows the switch contacts to open and the compressor clutch disengages.

### Low Refrigerant Charge Protection System

#### C-K-G Models

The compressor discharge pressure switch performs the function of shutting off the compressor when it senses low refrigerant pressure. The switch is located in the evaporator inlet line (high pressure). The switch electrically is wired in series between the compressor clutch and the master switch on the control. When the switch senses low pressure it breaks contact and opens the circuit to the compressor clutch, thus shutting off the A/C system and preventing compressor failure or seizure.

The compressor discharge pressure switch also performs the function of the ambient switch as the pressure at the switch varies directly with ambient temperatures. The compressor should **not** run below 25°F. ambient or 37 psi at the switch. The compressor should run in A/C modes above 45°F. ambient or 42 psi at the switch.

The switch interacts with other switches so that in an A/C system where the compressor will **not** operate above 45° ambient the following components should be checked for continuity:

1. Compressor discharge pressure switch.
2. Master switch (on control head).

If both switches show proper continuity, check the harness for shorts or improper ground conditions.

### CHEMICAL INGREDIENTS OF AN AIR CONDITIONING SYSTEM

All systems involve metals, refrigerant, and oil which are basic and essential. The desiccant, or dehydrating agent, and another chemical ingredient, synthetic rubber, makes it even more complex.

All of these ingredients have chemical properties which are entirely different from each of the others. By proper selection of the ingredients and controlled processes in manufacture, plus careful servicing procedures, they can be combined so that they provide many years of satisfactory and trouble-free operation.

Only one undesirable element added or allowed to enter the system can start a chain of chemical reactions which upsets stability and interferes with the operation of the unit.

### Chemical Instability and Refrigerant System Failures

A sealed refrigerating system is a complex physical-chemical combination which is designed for stability within certain operating limits. If these limits are exceeded, many physical and chemical reactions occur to the system. Since the results of these reactions within the

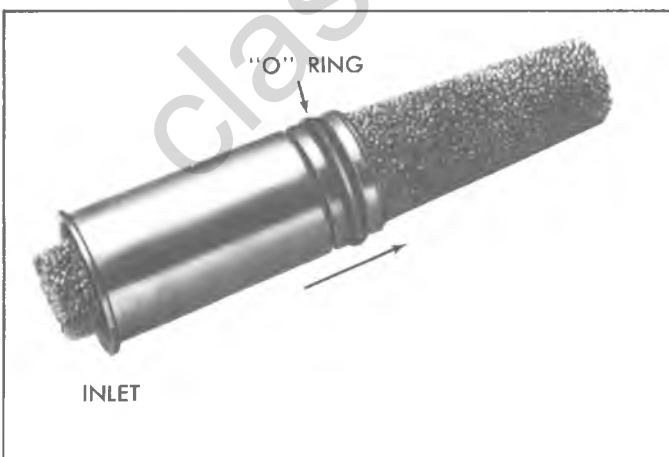

Fig. 38--Expansion Tube

system cannot be easily removed, they build up into a constantly accelerating vicious circle to eventually fail the system.

### Metals

In most cases, metals contribute to the decomposition of R-12 and oil in varying amounts. All metals are attacked by acids.

Each of the metals in common use in a system has been selected for a specific reason; heat conductivity, durability, strength, and chemical composition.

Under favorable conditions, the amount of decomposition of Refrigerant-12 and oil produced by these metals is negligible. If undesirable substances are added and the temperature is increased, the rate of decomposition and the production of harmful acids increases proportionally.

### Refrigerant

The chemical properties of refrigerants are very important factors in the stability of a system since the refrigerant penetrates to every part of the unit.

Among the many desirable properties of R-12, is its stability under operating conditions. While more stable than the other refrigerants under the same conditions, it can be caused to form harmful acids which will eventually fail the system.

### Oil

Oil is the most complex of all organic chemicals. Its stability in a refrigerating system is dependent upon the source of crude oil and its method of refining. A good refrigeration oil must be free of sludge, gum-forming substances and impurities such as sulphur. It must be stabilized to resist oxidation and must have a high degree of resistance to carbonization.

The chemical properties of the lubricating oil form another very important consideration in the chemical stability within the system. Like the refrigerant, it travels to every part of the system.

The factory obtains the finest oils which have been refined from the most desirable crudes. It is reprocessed at the factory before it is charged into a system or poured into a container for resale. Its viscosity and flash point are checked and it is forced through many sheets of filtering paper.

Even the containers in which it is poured for resale are processed. It is the cleanest, dryest, and purest oil that is humanly possible to make. Leaving the container uncapped even for a few minutes allows the oil to absorb moisture from the air.

System failures can result if contaminated oil is added to the system.

### Desiccant (Dehydrating Agent)

An ideal desiccant must have the following characteristics:

1. High capacity.
2. High efficiency.
3. Low tendency to powder.
4. Absorb moisture without reacting chemically with it.
5. Allow refrigerant to flow through it with minimum restriction.
6. Retain moisture at high temperature.

While some desiccants excel in several of the desirable characteristics, they are unsatisfactory in others.

Activated Silica Alumina is a most satisfactory desiccant; however, its ability to retain moisture is affected by its temperature. As the temperature increases, its ability decreases. This means that moisture which is retained at a lower temperature may be put back into the system at a higher temperature.

### PRIMARY CAUSES OF SYSTEM FAILURES

#### Leaks

A shortage of refrigerant causes oil to be trapped in the evaporator. Oil may be lost with the refrigerant at point of leakage. Both of these can cause compressor seizure.

Oil circulates in the globules with the vapor. It leaves the compressor by the action of the pistons and mixes with the refrigerant liquid in the condenser. The oil then enters the evaporator with the liquid and, with the evaporator properly flooded, is returned to the compressor through the low pressure line. Some of the oil returns as globules in the vapor but more importantly, it is swept as a liquid along the walls of the tubing by the velocity of the vapor. If the evaporator is starved, the oil cannot return in sufficient quantities to keep the compressor properly lubricated.

#### High Temperature and Pressure

An increase in temperature causes an increase in pressure. This accelerates chemical instability in clean systems. Other results are brittle hoses, "O" ring gaskets, and by-pass valve diaphragms with possible decomposition, broken compressor discharge reeds, and seized compressor bearings.

A fundamental law of nature accounts for the fact that when a substance, such as a refrigerant, is increased in temperature, its pressure is also increased.

Any chemical reactions caused by contaminants already in the system are greatly accelerated as the temperature increases. A 15° rise in temperature doubles the chemical action.

While temperature alone can cause the synthetic rubber parts to become brittle and possibly to decompose, the increased pressure can cause them to rupture or blow.

As the temperature and pressure increases, the stress and

strain on the discharge reeds also increases. This can result in broken reeds. Due to the effect of the contaminants caused by high temperature and pressure, compressor bearings can be caused to seize.

High temperature and pressure is also caused by air in the system.

### Air in the System

Air results from a discharged system or careless servicing procedures. This reduces system capacity and efficiency and causes oxidation of oil into gum and varnish.

When a leak causes the system to become discharged, the resulting vacuum within the system will cause air to be drawn in. Air in a system is a non-condensable gas and will build up in the condenser as it would in an air compressor tank. The resultant heat produced will contribute to the conditions discussed previously.

Many systems are contaminated and also reduced in capacity and efficiency by careless servicing procedures.

Too frequently, systems which have been open to the atmosphere during service operations have not been properly purged or evacuated. Air is also introduced into the system by unpurged gauge and charging lines. Remember that any air in the system is too much air.

### Poor Connections

Hose clamp type fittings must be properly made. Hose should be installed over the sealing flanges and with the end of the hose at the stop flange. The hose should never extend beyond the stop flange. Locate the clamp properly and torque as recommended. Be especially careful that the sealing flanges are not nicked or scored or a future leak will result.

When compression fittings are used, over-tightening can cause physical damage to the "O" ring gasket and will result in leaks. The use of torque and backing wrenches is highly recommended. When making a connection with compression fittings, the gaskets should always be first placed over the tube before inserting it in the connection.

Another precaution - inspect the fitting for burrs which can cut the "O" ring.

### Restrictions

Restrictions may be due to powdered desiccant or dirt and foreign matter. This may result in starved evaporator and loss of cooling, high temperature at the bypass hose, or a seized compressor.

When the amount of moisture in a system sufficiently exceeds the capacity of the desiccant, it can break down the desiccant and cause it to powder. The powder passes through the dehydrator screen with the refrigerant liquid and is carried to the expansion valve screen. While some of it may pass through the valve screen into the evaporator, it may quickly build up to cause a restriction.

Due to the fact that sufficient oil then cannot be returned to the compressor, it may seize.

### Dirt

Dirt, which is any foreign material, may come from cleaner residues, cutting, machining, or preserving oils, metal dust or chips, lint or dust, loose rust, soldering or brazing fluxes, paint or loose oxide scale. These can also cause seized bearings by abrasion or wedging, discharge and expansion valve failure, decomposition of refrigerant and oil, or corrosion of metal parts.

### Corrosion

Corrosion and its by-products can restrict valve and drier screens, restrict the expansion tube, roughen bearing surfaces or hasten fatiguing of discharge reeds. This can result in high temperature and pressure, decomposition or leaks. In any event, this means a damaged compressor.

From this, we can see the vicious circle that can be produced in a refrigerating system to cause its failure. Corrosion can be the indirect cause of leaks and leaks can be the direct cause of corrosion. We can also see the important role servicemen play in maintaining chemical stability.

The major cause of corrosion is moisture.

### Moisture

Moisture is the greatest enemy of refrigerating systems. Combined with metal, it produces oxide, Iron Hydroxide, and Aluminum Hydroxide. Combined with R-12, it produces Carbonic acid, Hydrochloric acid, and Hydrofluoric acid. Moisture can also cause freeze-up of an expansion valve and powdered desiccant.

Although high temperature and dirt are responsible for many difficulties in refrigerating systems, in most instances it is the presence of moisture in the system that accelerates these conditions. It can be said, therefore, that moisture is the greatest problem of all. The acids that it produces, in combination with both the metals



Fig. 39--System Contaminants

## 1A-40 HEATER AND AIR CONDITIONING

and the refrigerant, causes damaging corrosion. While the corrosion may not form as rapidly with R-12 as with some other refrigerants, the eventual formation is as damaging.

If the operating pressure and temperature in the evaporator is reduced to the freezing point, moisture in the refrigerant can collect at the orifice of the expansion valve and freeze. This temporarily restricts the flow of liquid causing erratic cooling.

As previously mentioned, moisture in excess of the desiccant's capacity can cause it to powder.

### Points to Remember

That the inside of the refrigerant system is completely sealed from the outside world. If that seal remains broken at any point--the system will soon be damaged.

That complete and positive sealing of the entire system is vitally important and that this sealed condition is absolutely necessary to retain the chemicals and keep them in a pure and proper condition.

That all parts of the refrigerant system are under pressure at all times, whether operating or idle, and that any leakage points are continuously losing refrigerant and oil.

That the leakage of refrigerant can be so silent that the complete charge may be lost without warning.

That refrigerant gas is heavier than air and will rapidly drop to the floor as it flows from a point of leakage.

That the pressure in the system may momentarily become as high as 480 lbs. per square inch.

That the total refrigerant charge circulates through the entire system at least once each minute.

That the compressor is continually giving up some lubricating oil to the circulating refrigerant and depends upon oil in the returning refrigerant for continuous replenishment. Any stoppage or major loss of refrigerant will therefore damage the compressor.

That the extreme internal dryness of a properly processed system is a truly desert condition, with the drying material in the receiver or accumulator holding tightly onto the tiny droplets of residual moisture.

That the attraction of the drying material for moisture is so powerful that if the receiver or accumulator is left open, moisture will be drawn in from the outside air.

That water added to the refrigerant will start chemical changes that can result in corrosion and eventual breakdown of the chemicals in the system. Hydrochloric acid is one result of an R-12 mixture with water.

That air in the refrigerant system may start reactions that can cause malfunctions.

That the drying agent in the receiver or accumulator is Activated Silica Alumina.

That the inert gas in the expansion valve-capillary line is carbon dioxide.

## SYSTEM CONTROLS

### Four-Season System (C-K Models) - Fig. 40

The system selector lever (air control lever) determines the mode of operation: OFF, A/C, VENT, HEATER, BILEVEL or DEF. When the system selector lever is placed in the A/C, BI-LEVEL or DEF positions, electrical circuit connection is made to the compressor clutch through the control panel switch and the discharge pressure switch. If the switch is closed (ambient temperature above 40°F.), the compressor will run. In the OFF, VENT or HEATER positions, the compressor is not energized.

The system selector lever also determines the direction of outlet air flow. Moving the lever from mode to mode varies the position of a sliding-type vacuum valve on the control. The position of the vacuum valve will supply vacuum to, or vent, vacuum diaphragms which position the upper and lower mode and defroster air doors in the selector duct assembly. The position of these air doors determines if output air flow is from heater outlet (OFF), the heater outlet with slight air flow from defroster nozzles (HEATER), heater and A/C outlets (VENT), A/C outlet only (A/C), heater, A/C and defroster outlets (BI-LEVEL), or the defroster nozzles with slight air flow from the heater outlet (DEF).

### Temperature Control

The temperature lever determines the temperature of outlet airflow by positioning the temperature door in the selector duct assembly, through the motion of a bowden cable linking the control panel lever to the temperature door. In addition, the temperature lever is connected to the vacuum valve on the control panel.

The vacuum valve supplies vacuum to the air inlet diaphragm. When the system is in A/C mode and the temperature lever is at full COLD, the air inlet door is positioned to reduce the supply of outside air to the system from 100% to approximately 20%. The remainder of the air input (80%) to the A/C system is then taken from the interior of the passenger compartment. This recirculation of interior air (recirc. operation) provides a source of fast cool down of interior temperatures.

### Fan Switch

The blower (FAN) switch provides a means of selecting the amount of airflow from the system by regulating the

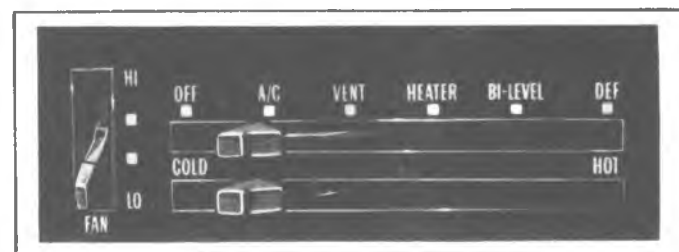

Fig. 40-Four-Season System Controls (C-K Models)



speed of the blower motor. There are, however, limitations to the control of blower speed. To provide constant ventilation, the blower motor electrical circuitry prevents the blower motor from being shut off when the ignition switch is on. Therefore, the blower speeds available are HI, LO and two medium speeds.

The control master switch incorporates an "override" function which overrides the blower speed switch and automatically provides HI blower speed when the system selector lever is in A/C and the temperature lever is set to full COLD.

**Overhead System (C-K Models)**

This system operates in conjunction with the Four-Season System. Since refrigerant flow is controlled by the front system, the only control provided for on the overhead system is a three-speed fan switch (LOW, MED, HI). The fan switch is mounted in the instrument panel, to the right of the steering column (fig. 41).

In the OFF position, the blower is inoperative; however, refrigerant is circulating in the system if the Four-Season System is ON. In any of the three blower positions (LOW, MED, HI), the blower will be operative regardless if the Four-Season System is ON.

NOTE: To obtain maximum cooling, the Four-Season System should be on A/C, temperature lever on COLD, blower switch on HI and the overhead unit blower switch should be on HI.

**C60 System (G Models)--Fig. 42**

The system selector level (air control lever) determines



Fig. 41--Overhead Unit Control (C-K Models)

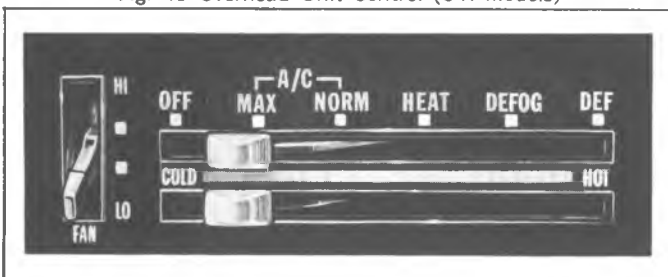

Fig. 42--C60 System Controls (G Models)

the mode of operation: OFF, MAX, NORM, HEAT, DEFOG or DEF. When the system selector lever is placed in the A/C, positions, electrical circuit connection is made to the compressor clutch through the control panel switch and the discharge pressure switch. If the switch is closed (ambient temperature above 40° F.), the compressor will run. In the OFF, HEAT, DEFOG or DEF positions, the compressor is not energized.

The system selector lever also determines the direction of outlet air flow. Moving the lever from mode to mode varies the position of a rotary vacuum valve on the control. The position of the vacuum valve will supply vacuum to, or vent, vacuum diaphragms which position the air and defroster doors in the heater distributor duct and the outside air door in the right side of the cowl plenum. The position of these doors determines if output air flow is from the A/C outlets using recirc air (MAX), of recirc and outside air (NORM), the heater outlet (HEAT), heater and defroster outlets (DEFOG), or the defroster nozzles with slight air flow from the heater outlet (DEF).

**Temperature Control**

*(A/C Modes)*

The temperature lever activates a potentiometer on the control assembly (connected in series with the amplifier on the control and thermister on the evaporator) to control compressor operation.

*(Heater-Defrost Modes)*

The temperature lever determines the temperature of outlet air flow by positioning the temperature door in the heater distributor assembly, through the motion of a bowden cable linking the control panel lever to the temperature door.

**Fan Switch**

The blower (FAN) switch provides a means of selecting the amount of airflow from the system by regulating the speed of the heater or A/C blower motor. There is no OFF position on the fan switch; however the blower is inoperative if the selector lever is placed in the OFF position. If the selector lever is placed in any of the heater or A/C modes, the appropriate blower is operative. The blower speeds available are LO, M1, M2 and HI.



Fig. 43--Overhead Unit Control (G Models)

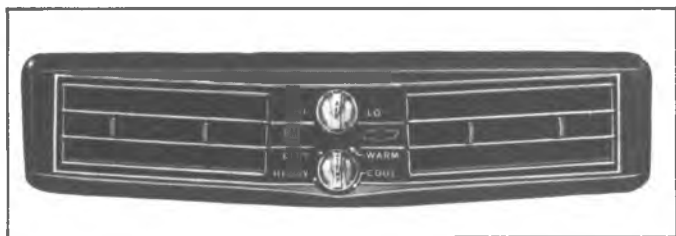

Fig. 44--Motor Home Unit Control

### Overhead System (G Models)

This system operates in conjunction with the C60 system. Since refrigerant is controlled by the C60 system, the only control provided on the rear overhead system is a three speed blower switch (fig. 43).

In the OFF position, the blower is inoperative; however, refrigerant is circulating in the system if the front system is ON. To operate the rear overhead system, simply select the desired blower speed (LOW, MED, HI).

**NOTE:** The rear unit will not operate unless the front unit is calling for cooling.

### Dash Mounted Unit (Motor Home Chassis Units)

This system is self contained and is mounted below the dash by the body manufacturer. System controls consist of an AIR knob and TEMP knob located in the center of the unit face plate (fig. 44).

#### Air Knob

Turning the AIR knob clockwise operates a three speed (LOW-MED-HI) blower motor.

#### Temp Knob

This knob is used to control the degree of cooling desired. Fully clockwise at CITY provides maximum cooling, while turning the knob to HIWAY provides adequate cooling for highway operation.

**NOTE:** Reduced cooling could be encountered when operating at highway speeds with the controls at the CITY setting. The heater must be fully off to obtain maximum cooling.

## GENERAL INFORMATION

In any vocation or trade, there are established procedures and practices that have been developed after many years of experience. In addition, occupational hazards may be present that require the observation of certain precautions or use of special tools and equipment. Observing the procedures, practices and precautions of servicing refrigeration equipment will greatly reduce the possibilities of damage to the customers' equipment as well as virtually eliminate the element of hazard to the serviceman.

### PRECAUTIONS IN HANDLING REFRIGERANT-12

Refrigerant-12 is transparent and colorless in both the gaseous and liquid state. It has a boiling point of 21.7°F below zero and, therefore, at all normal temperatures and pressures it will be a vapor. The vapor is heavier than air, and is nonflammable, nonexplosive, nonpoisonous (except when in contact with an open flame) and noncorrosive (except when in contact with water).

**WARNING:** The following precautions in handling R-12 should be observed at all times.

- resulting increase in pressure may cause the safety valve to release or the cylinder or can to burst.
- Cylinders or disposable cans should never be subjected to high temperature when adding refrigerant to the system. In most instances, heating the cylinder or can is required to raise the pressure in the container higher than the pressure in the system during the operation. It would be unwise to place the cylinder on a gas stove, radiator or use a blow torch while preparing for the charging operation, for a serious accident can result. Remember, high pressure means that great forces are being exerted against the walls of the container. A bucket of warm water, not over 125°F, or warm wet rags around the container is all the heat that is required.
- Do not weld or steam clean on or near the system. Welding or steam cleaning can result in a dangerous pressure buildup in the system.
- Discharging large quantities of R-12 into a room can usually be done safely as the vapor would produce no ill effects; however, in the event of an accidental rapid discharge of the system, it is recommended that inhalation of large quantities of R-12 be avoided. This caution is especially important if the area contains a flame producing device such as a gas heater. While R-12 normally is nonpoisonous, heavy concentrations of it in contact with a live flame will produce a toxic gas. The same gas will also attack all bright metal surfaces.
- If it is ever necessary to transport or carry a cylinder or can of refrigerant in a vehicle, keep it in the luggage compartment. Refrigerant should not be exposed to the radiant heat from the sun since the

- Protection of the eyes is of vital importance! When working around a refrigerating system, an accident may cause liquid refrigerant to hit the face. If the eyes are protected with goggles or glasses, no serious damage can result. Just remember, any R-12 liquid that touches you is at least 21.7°F below zero. If R-12 liquid should strike the eyes, here is what to do:
  1. Keep calm.
  2. Do not rub the eyes. Splash the affected area with quantities of cold water to gradually get the temperature above the freezing point. The use of mineral, cod liver or an antiseptic oil is important in providing a protective film to reduce the possibility of infection.
  3. As soon as possible, call or consult an eye specialist for immediate and future treatment.

## PRECAUTIONS IN HANDLING REFRIGERANT LINES

**CAUTION:** *The following precautions should be observed when handling refrigerant lines:*

- All metal tubing lines should be free of kinks, because of the restriction that kinks will offer to the flow of refrigerant. The refrigeration capacity of the entire system can be greatly reduced by a single kink.
- The flexible hose lines should never be bent to a radius of less than 4 times the diameter of the hose.
- The flexible hose lines should never be allowed to come within a distance of 2-1/2" of the exhaust manifold.
- Flexible hose lines should be inspected at least once a year for leaks or brittleness. If found brittle or leaking they should be replaced with new lines.
- Use only new lines that have been sealed during storage.

**WARNING:** Always wear safety goggles when opening refrigerant lines.

- When disconnecting any fitting in the refrigeration system, the system must first be discharged of all refrigerant. However, proceed very cautiously regardless of gauge readings. Open very slowly, keeping face and hands away so that no injury can occur if there happens to be liquid refrigerant in the line. If pressure is noticed when fitting is loosened, allow it to bleed off as described under "Purging the System" in this section.
- In the event any line is opened to atmosphere, it should be immediately capped to prevent entrance of moisture and dirt.
- The use of the proper wrenches when making connections on "O" ring fittings is important. The

use of improper wrenches may damage the connection. The opposing fitting should always be backed up with a wrench to prevent distortion of connecting lines or components. When connecting the flexible hose connections it is important that the swaged fitting and the flare nut, as well as the coupling to which it is attached, be held at the same time using three different wrenches to prevent turning the fitting and damaging the ground seat.

- "O" rings and seats must be in perfect condition. A burr or piece of dirt may cause a leak.
- Sealing beads on hose clamp connections must be free of nicks and scratches to assure a perfect seal.

## MAINTAINING CHEMICAL STABILITY IN THE REFRIGERATION SYSTEM

The metal internal parts of the refrigeration system and the refrigerant and oil contained in the system are designed to remain in a state of chemical stability as long as pure R-12 and uncontaminated refrigeration oil is used in the system.

However, when abnormal amounts of foreign materials, such as dirt, air or moisture are allowed to enter the system, the chemical stability may be upset. When accelerated by heat, these contaminants may form acids and sludge and eventually cause the breakdown of components within the system. In addition, contaminants may affect the temperature-pressure relationship of R-12, resulting in improper operating temperature and pressures and decreased efficiency of the system.

**CAUTION:** *The following general practices should be observed to ensure chemical stability in the system:*

- Whenever it becomes necessary to disconnect a refrigerant or gauge line, it should be immediately capped. Capping the tubing will also prevent dirt and foreign matter from entering.
- Tools should be kept clean and dry. This also includes the gauge set and replacement parts.
- When adding oil, the container should be exceptionally clean and dry due to the fact that the refrigeration oil in the container is as moisture-free as it is possible to make it; therefore, it will quickly absorb any moisture with which it comes in contact. For this same reason the oil container should not be opened until ready for use and then it should be capped immediately after use.
- When it is necessary to open a system, have everything you will need ready and handy so that as little time as possible will be required to perform the operation. Don't leave the system open any longer than is necessary.
- Finally, after the operation has been completed and the system sealed again, air and moisture should be evacuated from the system before recharging.

### J-8393 CHARGING STATION

The J-8393 Charging Station is a portable assembly of a vacuum pump, refrigerant supply, gauges, valves, and most important, a five (5) pound metering refrigerant charging cylinder. The use of a charging cylinder eliminates the need for scales, hot water pails, etc.

The chief advantage of this unit is savings. A very definite savings in refrigerant and time can be obtained by using this unit. Since the refrigerant is metered into the system by volume, the correct amount may be added to the system. This, coupled with the fact that the unit remains "plumbed" at all times and thus eliminates loss of refrigerant in purging of lines and hooking-up, combines to enable the operator to get full use of all refrigerant purchased.

All evacuation and charging equipment is hooked together in a compact portable unit (fig. 45). It brings air conditioning service down to the basic problem of hooking on two hoses, and manipulating clearly labeled valves.

This will tend to ensure that the job will be done without skipping operations. As a result, you can expect to save time and get higher quality work, less chance of an over or under charge, thus reducing comebacks.

The pump mount is such that the dealer may use his own vacuum pump. The gauges and manifold are in common

use. Thus a current air conditioning dealer can use the equipment on hand and avoid duplication.

### GAUGE SET

The gauge set (fig. 46) is an integral part of the J-8393 Charging Station. It is used when purging, evacuating, charging or diagnosing trouble in the system. The gauge at the left is known as the low pressure gauge. The face is graduated into pounds of pressure and, in the opposite direction, in inches of vacuum. This is the gauge that should always be used in checking pressures on the low pressure side of the system. When all parts of the system are functioning properly the refrigerant pressure on the low pressure side never falls below 0 pounds pressure. However, several abnormal conditions can occur that will cause the low pressure to fall into a partial vacuum. Therefore, a low pressure gauge is required.

The high pressure gauge is used for checking pressures on the high pressure side of the system.

The hand shutoff valves on the gauge manifold do not control the opening or closing off of pressure to the gauges. They merely close each opening to the center connector and to each other. During most diagnosing and service operation, the valves must be closed. Both valves will be open at the same time during purging, evacuating and charging operations.

The charging station provides two flexible lines for connecting the gauge set to the system components.

### VACUUM PUMP

A vacuum pump should be used for evacuating air and moisture from the air conditioning system.

The vacuum pump (fig. 47), is a component part of Charging Station J-8393, described previously.

**CAUTION:** The following precautions should be observed relative to the operation and maintenance of this pump:

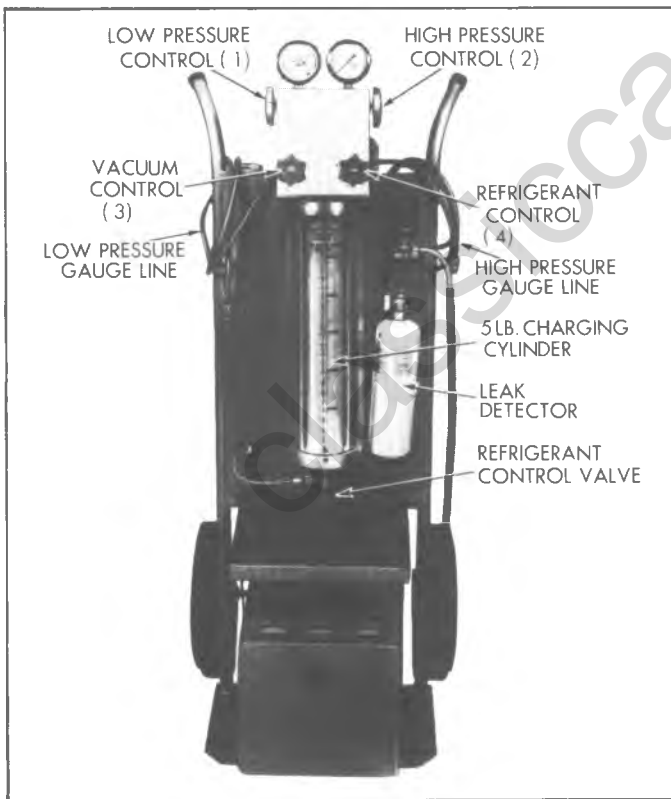

Fig. 45--J-8393 Charging Station

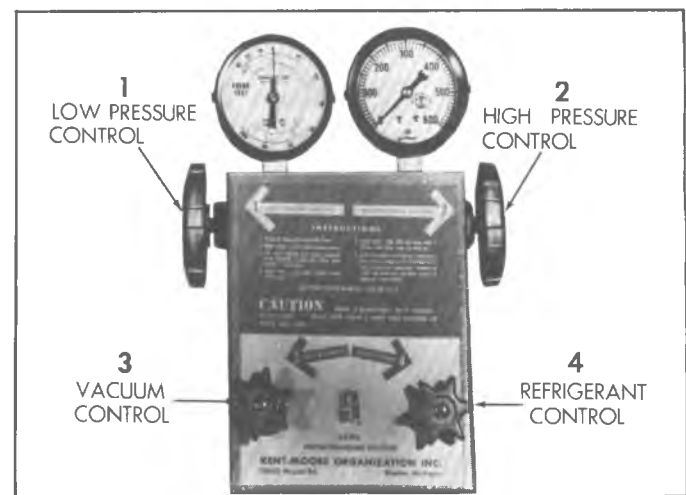

Fig. 46--Gauge Set

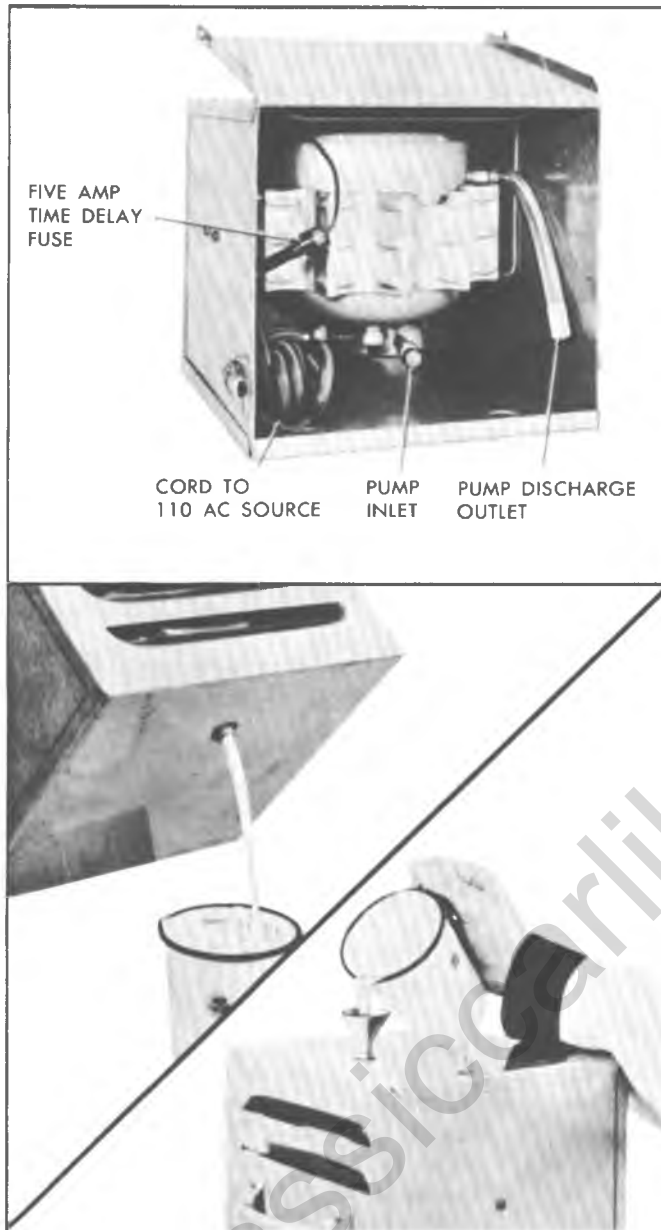

Fig. 47--Vacuum Pump

- Make sure dust cap on discharge outlet of vacuum pump is removed before operating.
- Keep all openings capped when not in use to avoid moisture being drawn into the system.
- Oil should be changed after every 250 hours of normal operation.

To change oil, simply unscrew hex nut located on back side of pump, tilt backward and drain out oil (fig. 47). Recharge with 8 ounces of vacuum pump oil Frigidaire 150 or equivalent. If you

desire to flush out the pump, use this same type clean oil. Do not use solvent. Improper Lubrication will shorten pump life.

- If this pump is subjected to extreme or prolonged cold, allow it to remain indoors until oil has reached approximate room temperature. Failure to warm oil will result in a blown fuse.
- A five ampere time delay cartridge fuse has been installed in the common line to protect the windings of the compressor. The fuse will blow if an excessive load is placed on the pump. In the event the fuse is blown, replace with a five ampere time delay fuse. **Do not use a substitute fuse** as it will result in damage to the starting windings.
- If the pump is being utilized to evacuate a burnt-out system, a filter must be connected to the intake fitting to prevent any sludge from contaminating the working parts, which will result in malfunction of the pump.
- Do not use the vacuum pump as an air compressor.

## LEAK TESTING THE SYSTEM

Whenever a refrigerant leak is suspected in the system or a service operation performed which results in disturbing lines or connections, it is advisable to test for leaks. Common sense should be the governing factor in performing any leak test, since the necessity and extent of any such test will, in general, depend upon the nature of the complaint and the type of service performed on the system.

### Leak Detector

Tool J-6084 (fig. 48) is a propane gas-burning torch which is used to locate a leak in any part of the system. Refrigerant gas drawn into the sampling tube attached to the torch will cause the torch flame to change color in proportion to the size of the leak. Propane gas fuel cylinders used with the torch are readily available commercially throughout the country.

**WARNING:** Do not use lighted detector in any place where combustible or explosive gases, dusts or vapors may be present.

### Operating Detector

1. Determine if there is sufficient refrigerant in the system for leak testing.
2. Open control valve only until a low hiss of gas is heard, then light gas at opening in chimney.
3. Adjust flame until desired volume is obtained. This

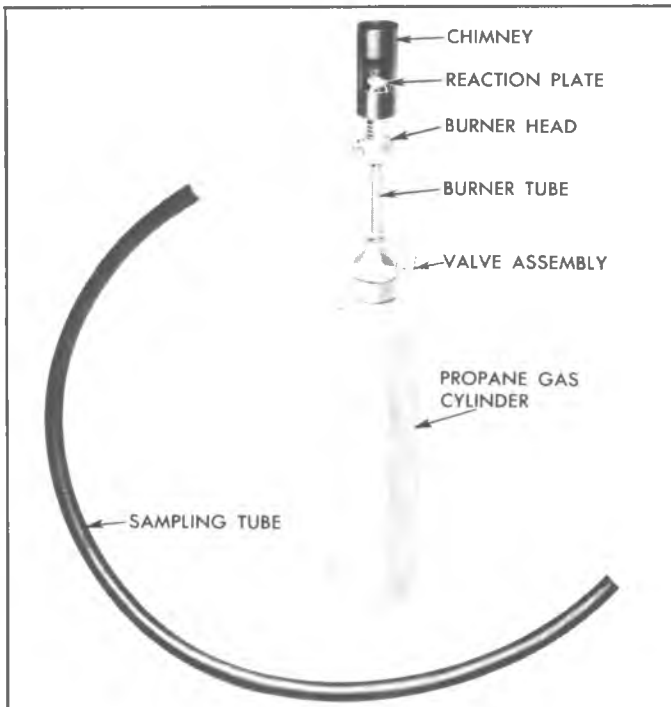

Fig. 48--Leak Detector

is most satisfactory when blue flame is approximately 3/8" above reactor plate. The reaction plate will quickly heat to a cherry red.

4. Explore for leaks by moving the end of the sampling hose around possible leak points in the system. Do not pinch or kink hose.

**NOTE:** Since R-12 is heavier than air, it is good practice to place open end of sampling tube immediately below point being tested, particularly in cases of small leaks.

**WARNING:** Do not breathe the fumes that are produced by the burning of R-12 gas in the detector flame, since such fumes can be toxic in large concentrations.

5. Watch for color changes. The color of the flame which passes through the reaction plate will change to green or yellow-green when sampling hose draws in very small leaks of R-12. Large leaks will be indicated by a change in color to a brilliant blue or purple; when the sampling hose passes the leaks, the flame will clear to an almost colorless pale-blue again. Observations are best made in a semi-darkened area. If the flame remains yellow when unit is removed from leak, insufficient air is being drawn in or the reaction plate is dirty.

**NOTE:** A refrigerant leak in the high pressure side of the system may be more easily detected if the system is operated for a few minutes, then shut off and checked

immediately (before system pressures equalize). A leak on the low pressure side may be more easily detected after the engine has been shut off for several minutes (system pressures equalized); this applies particularly to the front seal.

## AVAILABILITY OF REFRIGERANT-12

Refrigerant-12 is available in 30 lb. and in 15 oz. disposable containers.

Normally, air conditioning systems are charged making use of the J-8393 Charging Station which uses the 30 lb. container. Evacuating and charging procedures are noted later in this section.

The 15 oz. disposable cans are generally used for miscellaneous operations such as flushing.

**WARNING:** The following precautions should be observed when adding refrigerant to a system using 15 oz. disposable cans:

1. Do not charge while compressor system is hot.
2. Empty container completely before disposing.
3. Use opening valves designed for use with container - follow valve manufacturer's directions carefully.
4. Always use pressure gauges before and during charging.
5. NEVER connect on high pressure side of system or to any system having a pressure higher than indicated on refrigerant containers.
6. If inexperienced, seek professional assistance.

## COMPRESSOR OIL

Special refrigeration lubricant should be used in the system. This oil is as free from moisture and contaminants as it is possible to attain by human processes. This condition should be preserved by immediately capping the bottle when not in use.

See "Air Conditioning System Capacities" for the total system oil capacity.

Due to the porosity of the refrigerant hoses and connections, the system refrigerant level will show a definite drop after a period of time. Since the compressor oil is carried throughout the entire system mixed with the refrigerant, a low refrigerant level will cause a dangerous lack of lubrication. Therefore the refrigerant charge in the system has a definite tie-in with the amount of oil found in the compressor and an insufficient charge may eventually lead to an oil build-up in the evaporator.

## COMPRESSOR SERIAL NUMBER

The compressor serial number is located on the serial number plate on top of the compressor. The serial

number consists of a series of numbers and letters. This

serial number should be referenced on all forms and correspondence related to the servicing of this assembly.

## INSPECTION AND PERIODIC SERVICE

### PRE-DELIVERY INSPECTION

1. Check that engine exhaust is suitably ventilated.
2. Check the belt for proper tension.
3. With controls positioned for operation of the system, operate the unit for five minutes at approximately 2000 rpm. Observe the clutch pulley bolt to see that the compressor is operating at the same speed as the clutch pulley. Any speed variation indicates clutch slippage.
4. Before turning off the engine, check refrigerant charge (see "Refrigerant Quick Check Procedure").
5. Check refrigerant hose connections:  
**"O" Ring Connections** -- Check torque of fittings as charted later in this section under "Refrigerant Line Connections;" retorque if required. Leak test the complete system.
6. If there is evidence of an oil leak, check the compressor to see that the oil charge is satisfactory.  
 NOTE: A slight amount of oil leakage at the compressor front seal is considered normal.
7. Check the system controls for proper operation.

### 6000 MILE INSPECTION

1. Check unit for any indication of a refrigerant leak.

2. If there is an indication of an oil leak, check the compressor for proper oil charge.  
 NOTE: A slight amount of oil leakage at the compressor front seal is considered normal.
3. Check refrigerant charge (see "Refrigerant Quick Check Procedure").
4. Tighten the compressor brace and support bolts and check the belt tension.
5. Check refrigerant hose connections as in Step 5 of "Pre-Delivery Inspection."

### PERIODIC SERVICE

- Inspect condenser regularly to be sure that the fins are not plugged with leaves or other foreign material.
- Check evaporator drain tubes regularly for dirt or restrictions.
- At least once a year, check the system for proper refrigerant charge and the flexible hoses for brittleness, wear or leaks.
- Every 6000 miles check for low refrigerant level.
- Check belt tension regularly.

## EVACUATING AND CHARGING PROCEDURES

### AIR CONDITIONING SYSTEM CAPACITY

	Refrigerant Charge	Oil Charge
Four-Season System (C-K Models)	3 lbs. 12 oz.	10 oz. 525 Viscosity
Overhead System (C-K-G Models)	5 lbs. 4 oz.	13 oz. 525 Viscosity
C60 System (G Models)	3 lbs.	10 oz. 525 Viscosity
Dash Mounted Unit (Motor Home Chassis)	3 lbs. 4 oz.	10 oz. 525 Viscosity

### INSTALLING CHARGING STATION

1. High and low pressure gauge line fittings are

provided in the air conditioning system for attaching the Charging Station.

**C-K Models**--The low pressure fitting is located on the accumulator and the high pressure fitting on the evaporator inlet line.

**G Models**--The low pressure fitting is on the compressor inlet line and the high pressure fitting on the muffler.

**Motor Home Chassis**--The low pressure fitting is on the compressor inlet line and the high pressure fitting is on the compressor outlet line.

2. With the engine stopped, remove the caps from the cored valve gauge fittings.
3. Install Gauge Adapters J-5420 and J-9459 onto the high and low pressure lines of the Charging Station.
4. Be certain all the valves on the Charging Station are closed.

## 1A-48 HEATER AND AIR CONDITIONING

5. Connect the high pressure gauge line to the high pressure fitting on the system.
6. Referring to Figure 49, turn the high pressure control (2) one turn counterclockwise (open). Crack open the low pressure control (1) and allow refrigerant gas to hiss from the low pressure gauge line for three seconds, and then connect the low pressure line to the low pressure fitting on the system.

**WARNING:** When removing the gauge lines from the fittings, be sure to remove the adapters from the system fittings rather than the gauge lines from the adapter.

7. The system is now ready for purging or performance testing.

### PURGING THE SYSTEM

In replacing any of the air conditioning components, the system must be completely purged or drained of refrigerant. The purpose is to lower the pressure inside the system so that a component part can be safely removed.

1. With the engine stopped, install high and low pressure lines of Charging Station gauge set to the proper high and low pressure gauge fittings (See "Installing The Charging Station").

**CAUTION:** Before installing lines, be sure that all four controls on the gauge set are closed.

2. Disconnect vacuum line at Charging Station

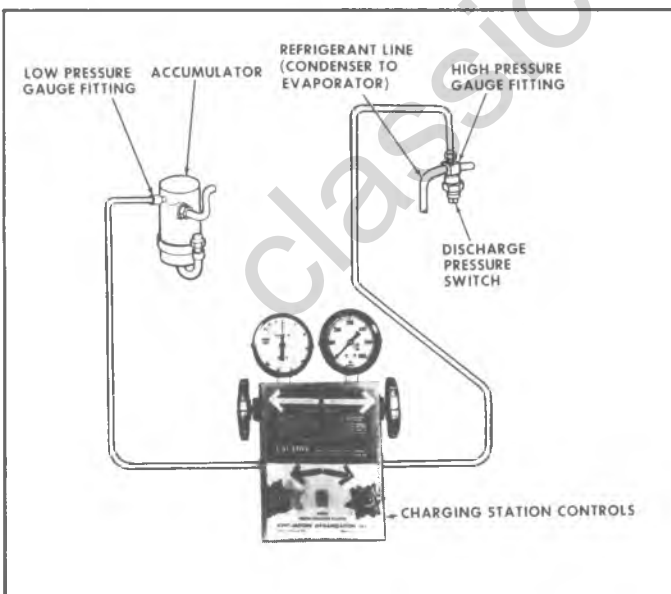

Fig. 49--Charging Schematic--C-K Truck Shown

vacuum pump and put the line in a covered can as shown in Figure 50.

**NOTE:** An empty 3 lb. coffee can with a plastic cover which has been cross-slitted (X'ed), to allow hose entry, works well for this purpose.

3. Fully open high (2) and low (1) pressure control valves, and allow refrigerant to purge from system at a rapid rate into the covered can.
4. Oil loss will be minimal. It may be added to the system during evacuation as described later.

**WARNING:** Visually check the accumulator for frost. The presence of frost is an indication that the system is not fully discharged. To complete purging, connect the vacuum line to the vacuum pump, turn on the vacuum pump and open vacuum control valve. An alternate method would be to place warm water soaked cloths (not exceeding 125°) around the accumulator to boil off the remaining refrigerant.

5. Toward the end of the purge stage, Tool J-24095 should be flushed with refrigerant to eliminate possible contamination.
  - a. Disconnect refrigerant line at supply tank.
  - b. Flush Tool J-24095 by cracking open valve on refrigerant tank. After flushing for approximately three seconds, close valve.
  - c. Temporarily refasten the tool.
  - d. Reconnect refrigerant line to supply tank.

### EVACUATING AND CHARGING THE SYSTEM

**GENERAL NOTE:** In all evacuating procedures shown below, the specification of 28-29 inches of Mercury vacuum is used. These figures are only attainable at or near Sea Level Elevation. For each 1000 feet above sea level where this operation is being performed, the specifications should be lowered by 1 inch. Example: at +5000 ft. elevation, only 23 to 24 inches of vacuum can normally be obtained.

Whenever the air conditioning system is open for any reason, it should not be put into operation again until it has been evacuated to remove air and moisture which may have entered the system.

The following procedures are based on the use of the J-8393 Charging Station:

#### Adding Oil

If necessary, refrigeration oil may be added to the system by the following method:



1. Install charging station and purge system as previously described.
2. After system has been purged, connect the vacuum line to the vacuum pump.
3. Measure oil loss collected as a result of purging the system.
  - a. Disconnect the Charging Station low pressure line. Install Tool J-24095 (with valve closed) onto the system low pressure fitting. Insert pick-up tube into graduated container of clean refrigerant oil (fig. 51).

**NOTE:** Tool J-24095 will hold 1/2 of an ounce of oil in the tool itself. So if 1 oz. has to be added, the level of the oil in the bottle should decrease 1-1/2 ounces to add 1 oz. to the system.

**CAUTION:** When removing the gauge lines from the fittings, be sure to remove the adapters from the system fittings rather than the gauge lines from the adapter.

- b. Turn on vacuum pump, and open vacuum control valve (slowly open high pressure side of manifold gauge set to avoid forcing oil out of refrigerant system and pump).

**NOTE:** When valve on Tool J-24095 is opened, the vacuum applied to the discharge side of the system will suck oil into system from container. Therefore, close observation of oil level in the container is necessary.

- c. Note level of oil in container. Open valve on oil adding tool until oil level in container is reduced

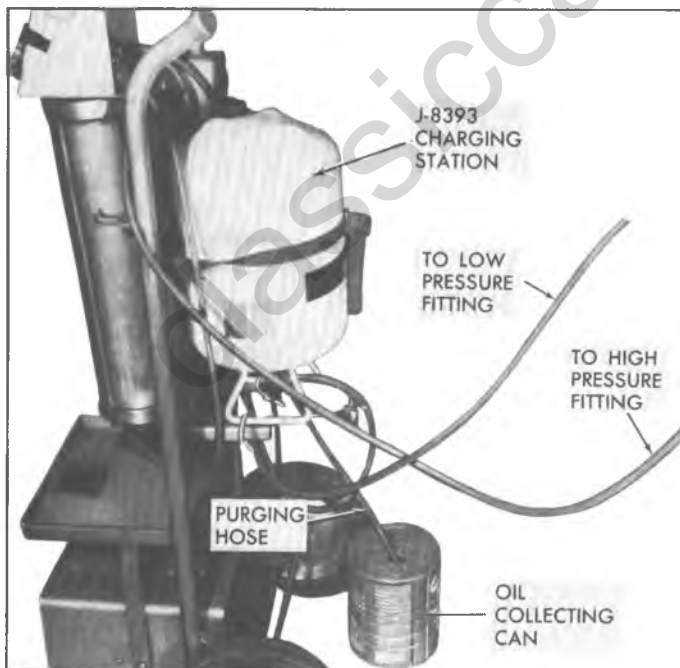

Fig. 50--Collecting Refrigerant Oil During "Purging"

by an amount equal to that lost during discharge of system plus 1/2 ounce, then close valve. **Take care not to add more oil than was lost.**

- d. Disconnect and cap Tool J-24095 and reinstall charging station low pressure line to the system. Open low pressure valve (1).

## Evacuation

After oil has been added to the system (as outlined above), run pump until 28-29 inches vacuum is obtained (See General Note under "Evacuating and Charging the System"). Continue to run pump for 10 minutes after the system reaches 28-29 inches vacuum.

**NOTE:** If 28-29 inches cannot be obtained, close Vacuum Control Valve (3) and shut off vacuum pump. Open Refrigerant Control Valve (4) and allow 1/2 pound of R-12 to enter system. Locate and repair all leaks. Purge this 1/2 pound and re-evacuate for 10 minutes.

1. During the ten minute evacuation period, prepare for charging the system by filling the charging cylinder as follows:
  - a. Open valve on bottom of charging cylinder allowing refrigerant to enter cylinder.

**NOTE:** It will be necessary to close bleed valve periodically to allow boiling to subside to check level in the sight glass of Charging Station cylinder.

- b. Bleed cylinder valve on top (behind control panel) as required to allow refrigerant to enter. When refrigerant reaches desired level (see "System Capacity"), close valve at bottom of cylinder and be certain bleed valve is closed securely.
2. Continue to evacuate for remainder of 10 minute period.
3. Turn hand shut-off valves at low and high pressure gauges of gauge set to full clockwise position with vacuum pump operating, then stop pump. Carefully check low pressure gauge for approximately two minutes to see that vacuum remains constant. If vacuum reduces, it indicates a leak in the system or gauge connections; locate and repair all leaks.

## Charging the System

1. Only after evacuating as above, is system ready for charging. Note reading on sight glass of charging cylinder. If it does not contain a sufficient amount of refrigerant for a full charge, fill to the proper level.
2. With High and Low Pressure Valves (1 and 2) open, close Vacuum Control Valve (3), turn off vacuum pump, open refrigerant control valve (4) and allow refrigerant to enter system.

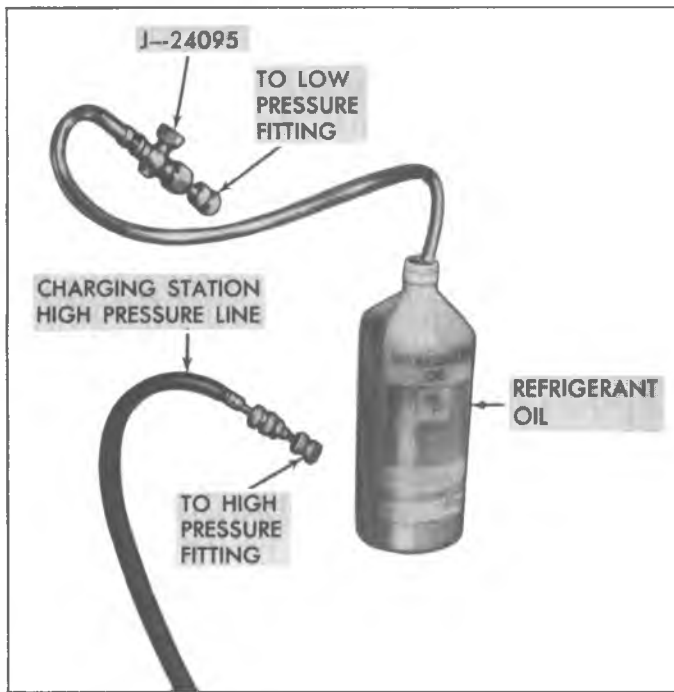

Fig. 51--Adding Refrigeration Oil Using Tool J-24095

**NOTE:** If the charge will not transfer completely from the station to the system, close the high pressure valve at the gauge set, set the air conditioning controls for cooling, check that the engine compartment is clear of obstructions, and start the engine. Compressor operation will decrease the low side pressure in the system.

System is now charged and should be checked as outlined below:

### Checking System Operation

1. Operate system for a maximum of five minutes at maximum cooling, high blower speed and with engine operating at 2000 RPM (exhaust should be vented if inside).
2. When system is stabilized, the pressure gauges on the charging station should read pressures corresponding to values listed under PERFORMANCE DATA.
3. When correct system pressures are observed, check system charge as described under "Refrigerant Quick Check Procedure".
4. Feel outlet air distribution to ensure that cold air is being distributed.
5. Disconnect gauge lines and cap fittings.

**CAUTION:** When removing gauge lines from fittings, be sure to remove the adapters from the fittings rather than the gauge lines from the adapters.

### PERFORMANCE TEST

Under normal circumstances, it will not be necessary to Performance Test a system as outlined below; however, in certain instances, the following procedure may be advantageous in diagnosing system malfunction.

The following fixed conditions must be adhered to in order to make it possible to compare the performance of the system being tested with the standards below:

1. Doors and windows closed. (Vehicle inside or in shade.)
2. Hood up and engine exhaust suitably ventilated.
3. Vehicle in NEUTRAL with engine running at 2000 rpm.
4. Air Conditioning controls set for -
  - Maximum cooling.
  - High blower speed
5. TEMP control set at "COLD" and all air conditioning outlets open.
6. Gauge set installed.
7. System settled out (run-in approximately 10 minutes).
8. A thermometer placed in front of vehicle grille and another in the right hand diffuser outlet.

**NOTE:** On Overhead Systems, place a third thermometer in the rear unit center outlet.

9. An 18" fan placed in front of the vehicle and blowing into the condenser.

**NOTE:** Higher temperatures and pressures will occur at higher ambient temperatures. In areas of high humidity it is possible to have thermometer and gauge readings approach but not reach the figures listed in the performance tables and still have a satisfactory operating unit. However, it is important to remember that low pressure has a direct relationship to nozzle outlet temperature. If pressure is too low, ice will gradually form on the evaporator fins, restricting air flow into the passenger area and resulting in insufficient or no cooling.

### PERFORMANCE DATA

The following Performance Data define normal operation of the system under the above conditions. Relative humidity does not appear in the tables because after running the prescribed length of time on recirculated air and maximum cooling, the relative humidity of the air passing over the evaporator core will remain at approximately 35% to 40% regardless of the ambient temperature or humidity.

Four-Season Air Conditioning (C-K Models)

(Refrigerant Charge - 3 Lbs. - 12 oz.)					
Temperature of Air Entering Condenser	70°	80°	90°	100°	110°
Engine rpm	2000				
Compressor Head Pressure *	150-205	170-220	190-240	220-270	240-290
Accumulator Pressure *	20-26	20-28	21-29	22-30	23-32
Discharge Air Temp. at Right Hand Outlet *	41-47	41-47	42-50	43-51	43-51

Overhead System (C-K Models)

(Refrigerant Charge - 5 lbs.-4 oz.)					
Temperature of Air Entering Condenser	70°	80°	90°	100°	110°
Engine rpm	2000				
Compressor Head Pressure *	135-185	160-210	195-245	230-280	270-320
Accumulator Pressure *	22-28	22-30	30-38	33-41	37-47
Discharge Air Temp. at Right Hand Outlet *	42-48	42-48	50-58	54-62	57-67
Rear Center Outlet *	43-49	47-53	50-58	55-63	58-68

C60 System (G Models)

(Refrigerant Charge — 3 lbs.)						
Temperature of Air Entering Condenser	70°	80°	90°	100°	110°	120°
Engine rpm	2000 RPM					
Compressor Head Pressure*	10-60	20-70	140-190	160-210	190-240	210-260
Suction Pressure*	3-9	3-9	3-9	4-10	7-14	10-18
Discharge Air Temp. at Right Upper Outlet*	42-48	42-48	43-49	45-57	49-56	53-60

Overhead System (G Models)

(Refrigerant Charge — 5 lbs.-4 oz.)						
Temperature of Air Entering Condenser	70°	80°	90°	100°	110°	120°
Engine rpm	2000					
Compressor Head Pressure*	50-200	160-210	200-250	225-275	250-300	280-320
Suction Pressure*	13-19	13-21	16-24	19-27	23-31	26-34
Discharge Air Temp. at Right Front Upper Outlet*	38-44	38-44	39-47	45-53	50-58	54-62

Rear system temperatures at center outlet run 5 - 10° higher than front system.

Dash Mounted Unit (Motor Home Chassis)

(Refrigerant Charge — 3 lbs.-4 oz.)						
Temperature of Air Entering Condenser	70°	80°	90°	100°	110°	120°
Engine rpm	2000					
Compressor Head Pressure*	110-120	135-145	160-170	190-200	220-230	260-270
Suction Pressure psi*	6	7	9	10	10	13
Discharge Air Temperature*	40-45	41-46	41-46	42-47	44-49	44-49

\*Just prior to compressor clutch disengagement.

CHECKING OIL

In the six cylinder compressor it is not recommended that the oil be checked as a matter of course. Generally, compressor oil level should be checked only where there is evidence of a major loss of system oil such as might be caused by:

- A broken refrigerant hose
- A severe hose fitting leak
- A very badly leaking compressor seal
- Collision damage to the system components

As a quick check on compressor oil charge, operate the engine at **idle** on maximum cold for approximately 10 minutes, turn off the engine and momentarily crack open the oil drain plug on bottom of the compressor letting a slight amount of oil drain out. Retighten plug. Again slightly crack open the plug. If oil comes out, the compressor has the required amount of oil.

NOTE: The oil may appear foamy. This is considered normal.

To further check the compressor oil charge, should the above test show insufficient oil, it is necessary to remove the compressor from the vehicle, drain and measure the oil as outlined under "Checking Compressor Oil Charge."

**Checking Compressor Oil Charge**

1. Run the system for 10 minutes at 500-600 engine rpm with controls set for maximum cooling and high blower speed.
2. Turn off engine, discharge the system, remove compressor from vehicle, place it in a horizontal position with the drain plug downward. Remove the drain plug and, tipping the compressor back and forth and rotating the compressor shaft, drain the oil into a clean container, measure and discard the oil.
3. Add new refrigeration oil to the compressor as follows.
  - a. If the quantity drained was 4 fluid oz. or more, add the same amount of new refrigeration oil to the replacement compressor.
  - b. If the quantity drained was less than 4 fluid oz., add 6 fluid oz. of new refrigeration oil to the replacement compressor.
  - c. If a new service compressor is being installed, drain all oil from it and replace only the amount specified in Steps 3a and 3b above.
  - d. If a field repaired compressor is being installed, add an additional 1 fluid oz. to the compressor.
4. In the event that it is not possible to idle the compressor as outlined in Step 1 to effect oil return to it, proceed as follows:

- a. Remove the compressor, drain, measure and discard the oil.
- b. If the amount drained is more than 1-1/2 fluid oz. and the system shows no signs of a major leak, add the same amount to the replacement compressor.
- c. If the amount drained is less than 1-1/2 fluid oz. and the system appears to have lost an excessive amount of oil, add 6 fluid oz. of clean refrigeration oil to replacement compressor, 7 fluid oz. to a repaired compressor.

If the oil contains chips or other foreign material, replace the receiver-dehydrator (expansion tube on C-K models) and flush or replace all component parts as necessary. Add the full specified volume of new refrigeration oil to the replacement compressor.

5. Add additional oil in the following amounts for any system components being replaced.

Evaporator Core .....	3 fluid oz.
Condenser .....	1 fluid oz.
Receiver-Dehydrator .....	1 fluid oz.
Accumulator .....	1 fluid oz.

**CAUTION:** When adding oil to the compressor, it will be necessary to tilt the rear end of the compressor up so that the oil will not run out of the suction and discharge ports. Do not set the compressor on the shaft end.

ClassicCarLibrary.com

## REFRIGERANT QUICK-CHECK PROCEDURE

The following procedure can be used to quickly determine whether or not an air conditioning system has a proper charge of refrigerant. This check can be made in a manner of minutes thus facilitating system diagnosis by pinpointing the problem to the amount of charge in the system or by eliminating this possibility from the overall checkout.

## C-K Models

1. Engine must be warm (thermostat open).
2. Hood and body doors open.
3. Selector lever set at A/C.
4. Temperature lever at first detent to the right of COLD (set for outside air).
5. Blower on HI.
6. Engine idling at 1000 RPM.
7. Feel temperature of evaporator inlet and accumulator outlet pipes with compressor engaged (fig. 52).
  - a. If both are cold this is a proper condition.
  - b. If inlet pipe is cooler than outlet pipe, system is low on charge.
    - Add a slight amount of refrigerant until both pipes feel the same (system stabilized – 3-5 minutes).
    - Then add 15 oz. (1 can) additional refrigerant.

## G Models and Motor Home Chassis Units

Start engine and place on fast idle. Set controls for maximum cold with blower on high.

Bubbles present in sight glass.	No bubbles. Sight glass clear.
---------------------------------	--------------------------------

System low on charge. Check with leak detector. Correct leak, if any, and fill system to proper charge.	System is either fully charged or empty. Feel high and low pressure pipes at compressor. High pressure pipe should be warm; low pressure pipe should be cold.
---	---

No appreciable temperature differential noted at compressor.	Temperature differential noted at compressor.
--	---

System empty or nearly empty. Turn off engine and connect Charging Station. Induce 1/2# of refrigerant in system (if system will not accept charge, start engine and draw 1/2# in through low pressure side). Check system with leak detector.	Even though a differential is noted, there exists a possibility of overcharge. An overfilled system will result in poor cooling during low speed operation (as a result of excessive head pressure). An overfill is easily checked by disconnecting the compressor clutch connector while observing the sight glass.
--	--

If refrigerant in sight glass remains clear for more than 45 seconds (before foaming and then settling away from sight glass) an overcharge is indicated. Verify with a performance check.

If refrigerant foams and then settles away from sight glass in less than 45 seconds, it can be assumed that there is a proper charge of refrigerant in system. Continue checking out system using performance checks outlined previously.

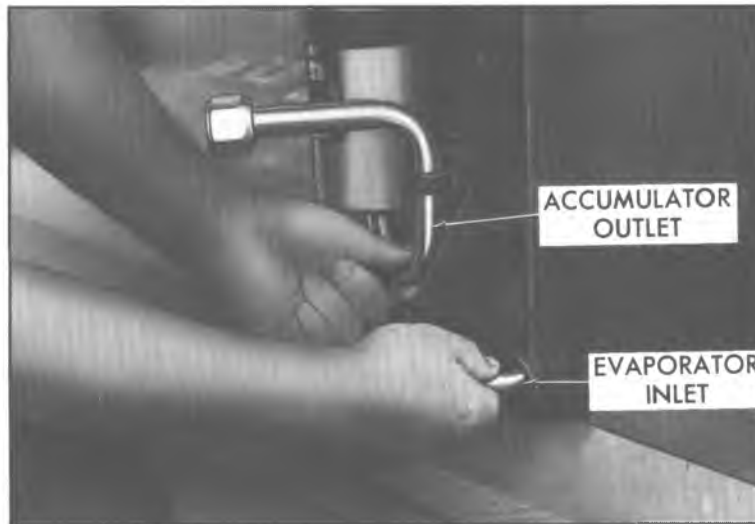

Fig. 52--Checking Evaporator Inlet and Accumulator Outlet Temperatures

## MAINTENANCE AND ADJUSTMENTS

### THERMOSTATIC SWITCH

C-K Systems and Motor Home Chassis Units make use of a thermostatic switch with either an air or fin sensing capillary. This capillary controls the switch by sensing the temperature of the air leaving the evaporator core (Motor Home Units) or temperature of the core fins (C-K models).

### Checking for Proper Operation

#### Motor Home Chassis Units

1. Install the gauge set and set up the vehicle as described under "Performance Test."
2. Movement of the temperature control knob should result in a definite change in suction pressure and cycling of the compressor clutch.
  - If compressor continued to operate regardless of the knob adjustment, it indicates that the switch points are fused which will lead to evaporator freeze-up. Replace the switch.
  - If the compressor does not operate, regardless of the position of the knob, a loss of the power element charge is indicated (provided that it has been established that power is supplied to the switch). This, of course, results in no cooling. Replace the switch.
  - Check the switch adjusting screw for stripped or otherwise damaged threads.

#### C-K Models

1. Install the gauge set and set up the vehicle as described under "Performance Test".

2. Set the control at A/C, HI blower, max COLD and run the engine at 2000 rpm.

- The thermostatic switch should cycle the compressor off when the low limit of the outlet air temperature is reached (see Performance Data). If it does not, the switch points are fused which will lead to evaporator freeze up. Replace the switch.
- If the compressor does not operate, a loss of power element charge is indicated (provided that it has been established that power is supplied to the switch). This, of course, results in no cooling. Replace the switch.
- Check the switch adjusting screw for stripped or otherwise damaged threads.

### Adjusting Switch

NOTE: Production and Service Replacement thermostatic switches are factory set and should **RARELY** require adjustment.

If, after the above checks, the switch seems to be operating properly and there appears to be no other reason for abnormal outlet air temperature, the switch may be adjusted for proper setting as follows:

1. Vehicle must be set up as described in "Performance Test."
2. The suction side of the system, read on the low pressure gauge, should pull down to the pressure shown in the chart in "Performance Data" under the ambient temperature at the time the switch is being set.

3. Remove the switch as outlined in the "Component Part Replacement" section of this manual.
4. Remove the switch non-metal end plate to gain access to the switch adjusting screw.
5. If the outlet temperature was higher than the prescribed temperature at the end of each cooling cycle, turn the adjusting screw a partial turn counterclockwise (fig. 53). If the outlet temperature was lower than prescribed temperature, turn the adjusting screw clockwise.

**NOTE:** One turn of the adjusting screw will change the outlet temperature **approximately** 4 degrees.

6. Reinstall switch end plate and reinstall switch. Reinstall face plate (Motor Home Chassis Units) before attempting a performance test. Be sure that the air sensing capillary has been replaced properly.
7. Check system performance. If further adjustment is needed, repeat Steps 3 through 6 until the prescribed pressure is reached.

**NOTE:** Do not attempt to run a Performance Check with the system disassembled since inaccurate readings would be the result. **ALWAYS** reinstall switch and capillary and any duct work before running a performance check.

### AMPLIFIER BOARD POTENTIOMETER (Fig. 54)

To cure a "too cold" or "not cold enough" capacity complaint, the sensor should be simulated by a  $400 \pm 1\%$ , 1/2 Watt resistor. By connecting the resistor as shown in Figure 54, the control pot can be rotated until the compressor clutch energizes. The procedure is as follows:

1. Remove the headlamp switch knob and then remove the instrument panel bezel.

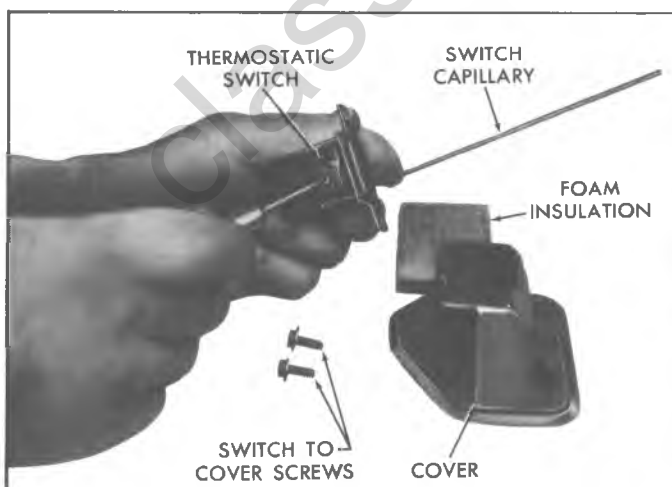

Fig. 53--Thermostatic Switch Adjustment

2. Remove the control to instrument panel screws.
3. Remove the left foot cooler bracket to instrument panel reinforcement screws and remove the foot cooler and duct.
4. With the system in the vehicle and the engine running, disconnect the terminals F and J from the connector at the control wiring harness connector.
5. Connect a  $400 \text{ ohm} \pm 1\%$ , 1/2 Watt resistor across terminals F and J.
6. Set the control temperature lever at COLD and then adjust by rotating the pot until the compressor clutch engages.
7. Reverse the adjustment by carefully rotating the pot until the compressor clutch just disengages.
8. Reverse Steps 1-4 above and check system operation.

### EXPANSION VALVE (Fig. 55)

An expansion valve is used on C-K Model Overhead Systems, all G Model systems and Motor Home Chassis Units.

A malfunction of the expansion valve will be caused by one of the following conditions; valve stuck open, valve stuck closed, broken power element, a restricted screen or an improperly located or installed power element bulb.

Attachment of the expansion valve bulb to the evaporator outlet pipe is very critical. The bulb must be attached tightly to the pipe and must make good contact with the pipe along the entire length of the bulb. A loose

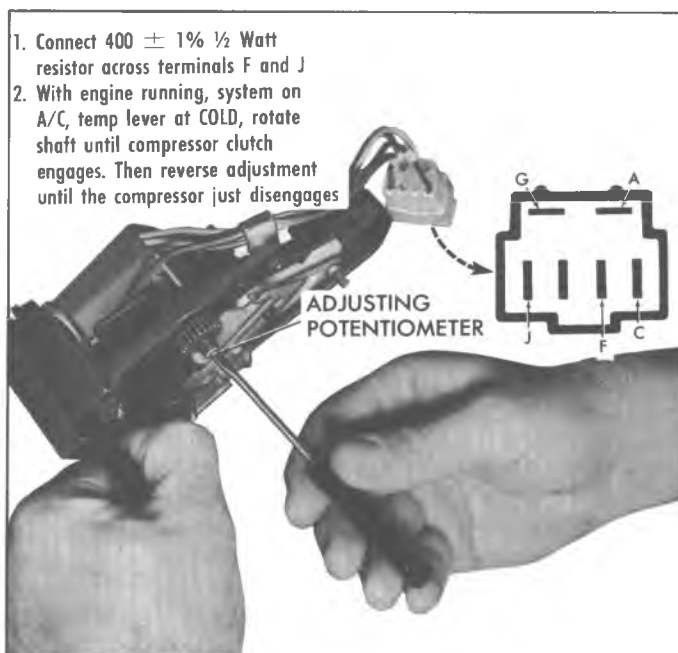

Fig. 54--Amplifier Board Potentiometer Adjustment

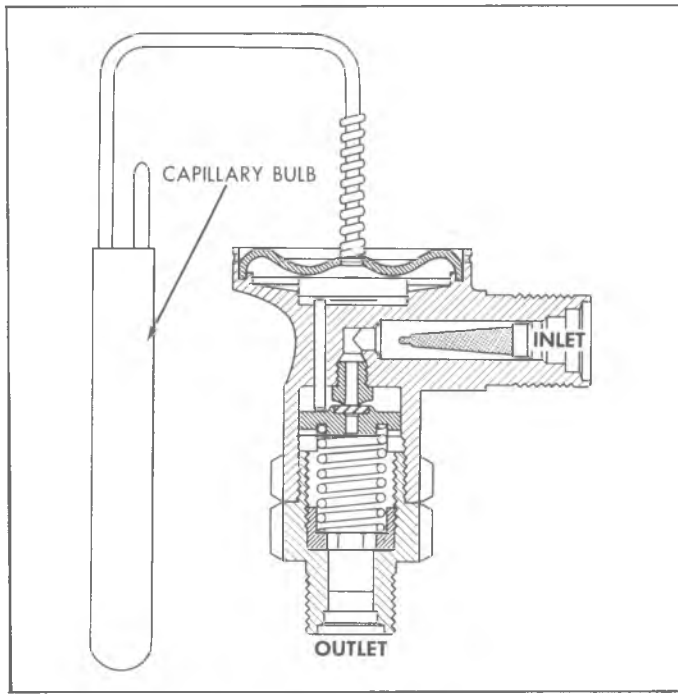

Fig. 55--Expansion Valve

bulb will result in high "high side" pressures and poor cooling.

Indications of expansion valve trouble provided by the Performance Test are as follows:

#### VALVE STUCK OPEN

Noisy Compressor.

No Cooling - Freeze Up.

#### VALVE STUCK CLOSED, PLUGGED SCREEN OR BROKEN POWER ELEMENT

Very Low Suction Pressure.

No Cooling.

#### POORLY LOCATED POWER ELEMENT BULB

Normal Pressure.

Poor Cooling.

#### Check for Defective Valve

The following procedure must be followed to determine if a malfunction is due to a defective expansion valve.

1. Check to determine if the system will meet the performance test as outlined previously. If the expansion valve is defective, the low pressure readings will be above specification.
2. The loss of system performance is not as evident when the high side pressure is below 200 PSI. Therefore, it may be necessary to increase the system high side pressure by partially blocking the condenser. Disconnect the blower lead wire and repeat the "Performance Check" to determine if the low side pressure can be obtained.
3. The system will also indicate a low refrigerant charge by bubbles occurring in the sight glass.

#### ENGINE IDLE COMPENSATOR

This additional aid to prevent stalling during prolonged hot weather periods is included with all air conditioned vehicles. The idle compensator is a thermostatically controlled air bleed which supplies additional air to the idle mixture. On V-8 engines, with factory installed air conditioning systems, the compensator is located within the carburetor and is accessible when the engine air cleaner is removed.

## GENERAL REPAIR PROCEDURES

### PREPARING SYSTEM FOR REPLACEMENT OF COMPONENT PARTS

Air conditioning, like many other things, is fairly simple to service once it is understood. However, there are certain procedures, practices and precautions that should be followed. For this reason it is strongly recommended that the preceding information in this section be studied thoroughly before attempting to service the system.

Great emphasis must be placed upon keeping the system clean. Use plugs or caps to close system components and hoses when they are opened to the atmosphere. Keep your work area clean.

In removing and replacing any part which requires unsealing the refrigerant circuit the following operations, which are described in this section, must be performed in the sequence shown.

1. Purge the system by releasing the refrigerant to the atmosphere.
2. Remove and replace the defective part.
3. Evacuate, charge and check the system.

**WARNING:** Always wear protective goggles when working on refrigeration systems. Goggles J-5453 are included in the set of air conditioning special tools. Also, beware of the danger of carbon monoxide fumes by avoiding running the engine in closed or improperly ventilated garages.

### FOREIGN MATERIAL IN THE SYSTEM

Whenever foreign material is found in the system, it



must be removed before restoring the system to operation.

In the case of compressor mechanical failure, perform the following operations:

1. Remove the compressor.
2. Remove the receiver-dehydrator or expansion tube and discard the unit.
3. Flush the condenser to remove foreign material which has been pumped into it.
4. Disconnect the line at the evaporator core inlet (C-K Four-Season System) or inlet line to the expansion valve (except C-K Four-Season System). Inspect the expansion tube or inlet screen of the expansion valve for the presence of metal chips or other foreign material. If the tube or screen is plugged, replace it. Reconnect the line to the evaporator core or expansion valve.
5. Install the replacement compressor.
6. Add the necessary quantity of oil to the system (one fluid ounce because of receiver-dehydrator replacement plus the quantity needed for the replacement compressor -- see "Checking Compressor Oil Charge" under "Checking Oil."
7. Evacuate, charge and check system.

**REFRIGERANT LINE CONNECTIONS**

**"O" Rings**

Always replace the "O" ring when a connection has been broken. When replacing the "O" ring, first dip it in clean refrigeration oil. Always use a backing wrench on "O" ring fittings to prevent the pipe from twisting and damaging the "O" ring. Do not overtighten. Correct torque specifications are as follows:

**CAUTION:** Where steel to aluminum connections are being made, use torque for aluminum tubing.

Metal Tube O.D.	Thread and Fitting Size	Steel Tubing Torque*	Alum. Tubing Torque*
1/4	7/16	13	6
3/8	5/8	33	12
1/2	3/4	33	18
5/8	7/8	33	24
3/4	1-1/16	33	30

\* Foot Pounds

**Hose Clamps**

When hose clamp connections are encountered, special procedures are necessary for both removal and installation.

**Removal**

1. Carefully, with a sharp knife, make an angle cut in the hose as shown in Figure 56. This should loosen the hose so that it may be worked off the fitting.
2. Cut off slit end of hose.

**CAUTION:** Use only approved refrigeration hose. Never use heater hose. Use extreme care not to nick or score the sealing beads when cutting off the hose. Cutting the hose lengthwise may result in this problem.

**Installation**

1. Coat tube and hose with clean refrigeration oil.
2. Carefully insert hose over the three beads on the fitting and down as far as the fourth, or locating bead. Hose must butt against this fourth bead.

**CAUTION:** Use no sealer of any kind.

3. Install clamps on hose, hooking the locating arms over the cut end of the hose.
4. Tighten the hose clamp screw to 35-42 in. lbs. torque. DO NOT RETORQUE. The clamp screw torque will normally decrease as the hose conforms to the force of the clamp. The screw should be retorqued only if its torque falls below 10 in. lbs. In this case, retorque to 20-25 in. lbs. Further tightening may damage the hose.

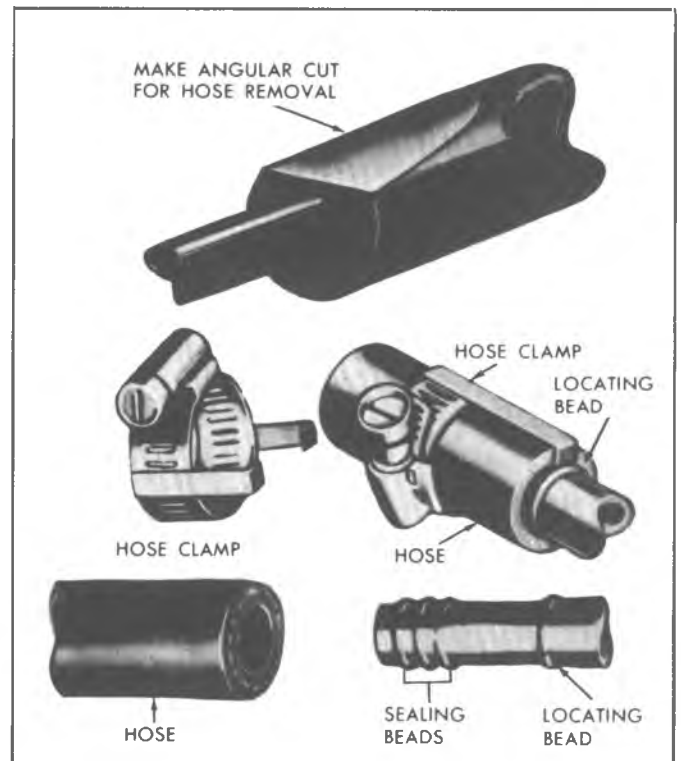

Fig. 56--Hose Clamp Connections

## REPAIR OF REFRIGERANT LEAKS

Any refrigerant leaks found in the system should be repaired in the manner given below:

### Leaks at "O" Ring Connection

1. Check the torque on the fitting and, if too loose, tighten to the proper torque. Always use a backing wrench to prevent twisting and damage to the "O" ring. Do not overtighten. Again leak test the joint.
2. If the leak is still present, discharge the refrigerant from the system as described under "Evacuating and Charging Procedures."
3. Inspect the "O" ring and the fitting and replace if damaged in any way. Coat the new "O" ring with clean refrigeration oil and install carefully.
4. Retorque the fitting, using a backing wrench.
5. Evacuate, charge and check the system.

### Leaks at Hose Clamp Connection

1. Check the tightness of the clamp itself and tighten if necessary. Recheck for leak.
2. If leak has not been corrected, discharge the system and loosen clamp and remove hose from connection. Inspect condition of hose and connector. Replace scored or damaged parts.
3. Dip end of new hose in clean refrigeration oil and carefully reinstall over connector. Never push end of hose beyond the locating bead. Properly torque the clamp.
4. Evacuate, charge and check the system.

### Compressor Leaks

If leaks are located around the compressor shaft seal or shell, replacement of necessary seals should be made as outlined under "Compressor" in the Overhaul Manual.

NOTE: A slight amount of oil leakage past the compressor front seal is considered normal.

## REFRIGERANT HOSE FAILURE

After a leak or rupture has occurred in a refrigerant hose, or if a fitting has loosened and caused a considerable loss of refrigerant and oil, the entire system should be flushed and recharged after repairs have been made. If the system has been open to atmosphere for any prolonged period of time the receiver-dehydrator or accumulator should be replaced.

Because of the length of the hoses on these systems, hose leaks may be repaired using the following procedure:

1. Locate the leak. This may require removing the body inner side panels to gain access to the hoses (Overhead Systems).
2. Discharge the system.
3. Cut out the leaking portion of the hose, making

sure that all of the failed portion is removed. If only a very small portion of the hose was removed, it may be possible to splice the two ends together using a special hose connector and two hose clamps. If several inches of hose must be removed, a new piece of hose should be spliced in using two connectors and four hose clamps. Dip the ends of the hoses in clean refrigeration oil before installing the hoses onto the connector. Never push the end of the hose beyond the locating bead of the connector. Torque the clamp to 35-42 in. lbs.

NOTE: Be sure to replace the hose in the body in the same manner as when removed. If the hose protective grommets are badly mutilated, they should be replaced.

4. Evacuate, charge and check the system.

## COMPRESSOR

### C-K Models

#### Removal (Fig. 57)

1. Purge the refrigerant from the system.
2. Remove connector attaching bolt and connector. Cap or plug open connections at once.
3. Disconnect electrical lead to clutch actuating coil.
4. Loosen brace and pivot bolts and detach belt.
5. Remove the nuts and bolts attaching the compressor brackets to the mounting bracket. Remove the compressor.
6. Before beginning any compressor disassembly, drain and measure oil in the compressor. Check for evidence of contamination to determine if remainder of system requires servicing. Compressor servicing information is located in the Overhaul Manual.

#### Installation

1. If oil previously drained from the compressor upon removal shows no evidence of contamination, replace a like amount of fresh refrigeration oil into the compressor before reinstallation. If it was necessary to service the entire system because of excessive contamination in the oil removed, install a full charge of fresh refrigeration oil into the compressor.
2. Position compressor on the mounting bracket and install all nuts, bolts and lock washers.
3. Install the connector assembly to the compressor rear head, using new "O" rings coated with clean refrigeration oil.
4. Connect the electrical lead to the coil and install and adjust compressor belt.
5. Evacuate, charge and check the system.

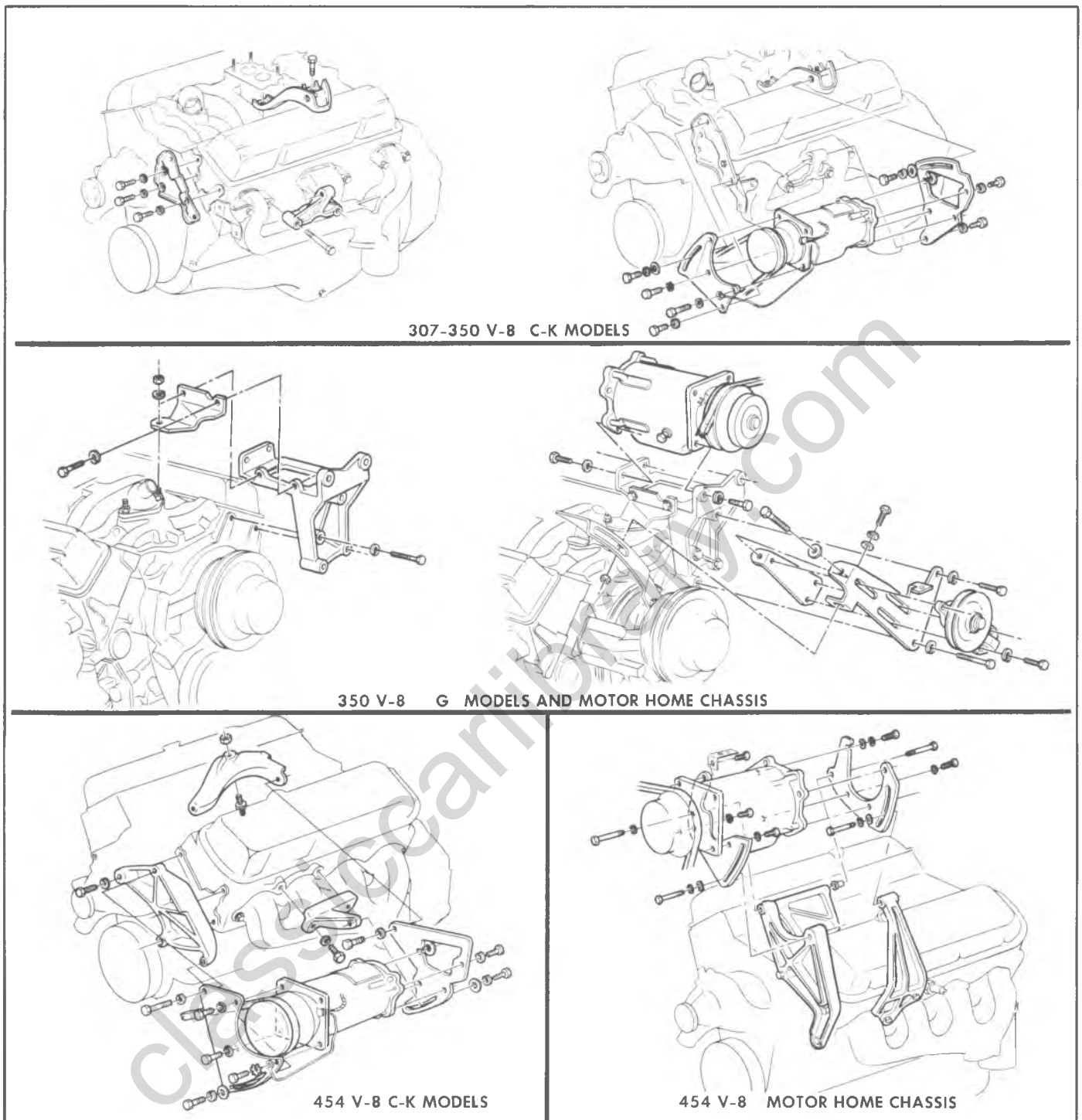

307-350 V-8 C-K MODELS

350 V-8 G MODELS AND MOTOR HOME CHASSIS

454 V-8 C-K MODELS

454 V-8 MOTOR HOME CHASSIS

Fig. 57--Compressor Mountings

### G and Motor Home Chassis Models

#### Removal (Fig. 57)

1. Disconnect battery ground cable.
2. Disconnect compressor clutch connector.
3. Purge the system of refrigerant.
4. Release the belt tension at the idler pulley and
5. **G Models**--Remove the two bolts and two clamps that hold the engine cover and remove the cover.
6. Remove the air cleaner to aid access to the compressor.

remove the belt from the compressor pulley. On some vehicles it may be necessary to remove the crankshaft pulley in order to remove the belt.

## 1A-60 HEATER AND AIR CONDITIONING

7. Remove fitting and muffler assembly and cap or plug all open connections.
8. Remove the nuts and bolts attaching the compressor to the bracket.
9. Remove the engine oil tube support bracket bolt and nut from the compressor, also compressor clutch ground lead.

Before beginning any compressor disassembly, drain and measure oil in the compressor. Check for evidence of contamination to determine if remainder of system requires servicing. Compressor Servicing information is located in the Overhaul Manual.

### Installation

1. If the oil drained from the compressor showed no evidence of contamination, replace a like amount of fresh refrigeration oil into the compressor before reinstallation. If it was necessary to service the entire system because of excessive contamination in the oil removed, install a full charge of fresh refrigeration oil in the compressor. (See Checking Compressor Oil Charge in the Service Manual.)
2. Position compressor on the mounting bracket and install all nuts, bolts, lock washers, and ground wire.
3. Install the connector assembly to the compressor rear head, using new "O" rings coated with clean refrigeration oil.
4. Connect the electrical lead to the coil and install and adjust compressor belt, using idler pulley. See "Compressor Belt Tension Adjustment."
5. Evacuate, charge and check the system.
6. Replace air cleaner. On G models, replace the engine cover.
7. Connect the battery ground cable.

### Compressor Belt Tension Adjustment

Adjust the compressor belt to the specifications shown in the Tune-Up chart in the Engine section of the Service Manual.

**NOTE:** On some G and Motor Home Chassis models it may be necessary to increase idler pulley slack adjustment. This may be accomplished by (1) Remove and discard the idler adjustment bolt. (2) Remove the idler backing plate and elongate all 3 adjusting slots 1/2 inch inboard or outboard as required. (3) Reinstall the idler assembly and adjust belt tension using a lever (screwdriver, etc.) to move the pulley outboard until proper belt tension is reached. If the belt is being replaced it may be necessary to remove and replace the throttle cable during the belt replacement. If so check throttle cable adjustment upon completion. It may also be necessary to remove the crankshaft pulley to install a new compressor belt.

### COMPRESSOR FAILURE

If the compressor has failed mechanically to the extent that metal chips and shavings are found in it, the system should be checked for foreign material and cleaned as described under Foreign Material in the System.

### FALSE COMPRESSOR SEIZURE

Slipping or broken air conditioning drive belts and/or scored clutch surfaces may be experienced on initial start up of an air conditioning compressor after an extended period of storage or non-operation of the compressor. This would indicate a seized compressor; however, an overhaul or replacement of the compressor may not be necessary.

During extended periods of non-operation, changes in temperature cause the refrigerant in the air conditioning compressor to expand and contract. During this movement, lubricating oil carried by the refrigerant tends to migrate from highly polished surfaces in the compressor such as the ball seats and wobble plate. Without lubricating oil at these polished surfaces, they "wring" together and appear to be seized.

Before the time and expense of an overhaul is invested, use the following check to determine if the compressor is actually seized. With a wrench on the compressor shaft lock nut or Spanner Wrench J-9403 on the clutch drive plate, "rock" the shaft in the opposite direction of normal rotation. After the compressor is broken loose, "rock" the shaft back and forth. This should be sufficient to return lubricating oil to the "wring" surfaces and allow the compressor shaft to be turned by hand. Once the compressor turns freely, rotate the compressor at least three complete turns. Start the engine and operate the compressor for a minimum of one minute.

This procedure will not affect a compressor that is actually seized but should be attempted before overhauling a compressor known to be idle for a month or longer.

### COLLISION PROCEDURE—ALL SYSTEMS

Whenever a vehicle equipped with an air conditioning unit is involved in a collision or wreck, it should be inspected as soon as possible. The extent of damage to any or all of the component parts and the length of time the system has been exposed to the atmosphere will determine the replacement of parts and processing that will be required. The greater the length of time of exposure to the atmosphere, the greater will have been the chances for air, moisture and dirt to have entered and damaged the system. Every case may be entirely different so it is not possible to establish a hard and fast procedure to follow each time. Good judgment must be used to determine what steps should be taken in each specific case.

The following procedure is presented as a guide for use when inspecting a damaged vehicle equipped with air conditioning.

1. Remove the drive belt.
2. Visually inspect the condenser, accumulator, receiver-dehydrator, compressor, mounting brackets, conditioning unit, all connecting lines, and all controls to determine the extent and nature of the damage.
  - a. No repairs, such as soldering, welding or brazing, should be attempted on the condenser because of its construction. If the vapor passages in the horizontal tubes or return bends or manifolds have been damaged in any way, the condenser should be replaced with a new one.
  - b. The accumulator or receiver-dehydrator should be replaced if there is any evidence of its having sustained either internal damage or a fracture at any of the lines or welded joints or if the system has been exposed to the atmosphere for an undetermined period of time.
  - c. Examine the compressor for any visible external damage.
  - d. The evaporator should be examined for damage and, if necessary, removed or replaced or the entire unit processed where damaged or exposed to the atmosphere.
  - e. All connecting lines and flexible hoses should be examined throughout their entire length for damage. If damaged in any manner, replace with new lines.
  - f. Check all controls and connecting wires for damage and replace with new parts where needed.
  - g. Check the clutch pulley for proper operation and freedom from damage.
3. Install Charging Station.
4. Purge the system.
5. Remove the compressor from mounting and remove the oil test fitting.
6. Pour out the oil into a clean glass container and examine it for any foreign substance such as dirt, water, metal particles, etc. If any of these are present, the compressor, expansion tube, and accumulator or receiver-dehydrator should be replaced and the other system components should be flushed with liquid refrigerant.
7. If the oil is clean and free of any harmful substance, replace oil with Frigidaire 525 Viscosity Oil, or equivalent.
 

NOTE: If the system components have been replaced or flushed, replace the full charge of oil. If not, add no more fresh oil than was drained in Step 6.
8. Charge up the compressor to cylinder or can pressure and leak test the compressor seals prior to installation of compressor.
9. Reinstall the compressor and evacuate the system by following the Evacuating Procedure.
10. Introduce R-12 vapor at cylinder (room) temperature and pressure.
11. Leak test all fittings and connections and give particular attention to a leak test at the compressor shaft seal if compressor has not been leak tested on the bench.
12. Complete system processing and charge system.

## COMPONENT PART REPLACEMENT FOUR-SEASON SYSTEM--C-K MODELS

### CONDENSER

#### Replacement (Fig. 58)

1. Disconnect battery ground cable.
2. Purge the system of refrigerant.
3. Remove the grille assembly.
4. Remove the radiator grille center support.
5. Remove the left grille support to upper fender support (2) screws.
6. Disconnect the condenser inlet and outlet lines and the outlet tube line at the right end of the condenser. Cap or plug all open connections at once.
  7. Remove the condenser to radiator support screws.
  8. Bend the left grille support outboard to gain clearance for condenser removal.
  9. Remove the condenser assembly by pulling it forward and then lowering it from the vehicle.
  10. To install a new condenser, reverse Steps 1-9 above. Add one fluid ounce of clean refrigeration oil to a new condenser.
 

NOTE: Use new "O" rings, coated with clean refrigeration oil, when connecting all refrigerant lines.
  11. Evacuate, charge and check the system.

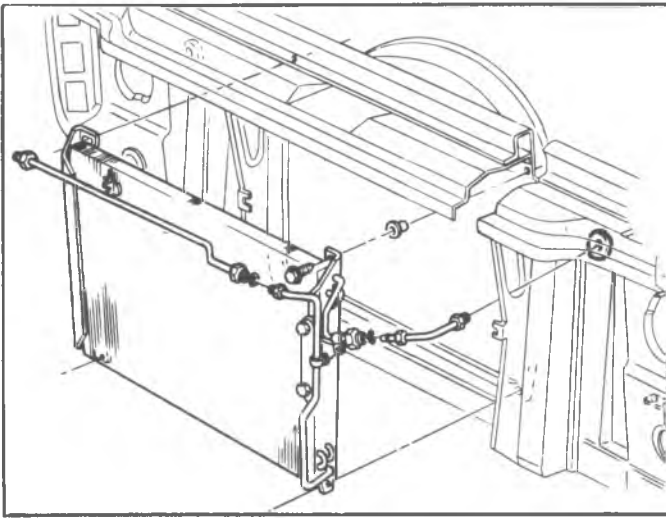

Fig. 58--Condenser Installation (C-K Models)

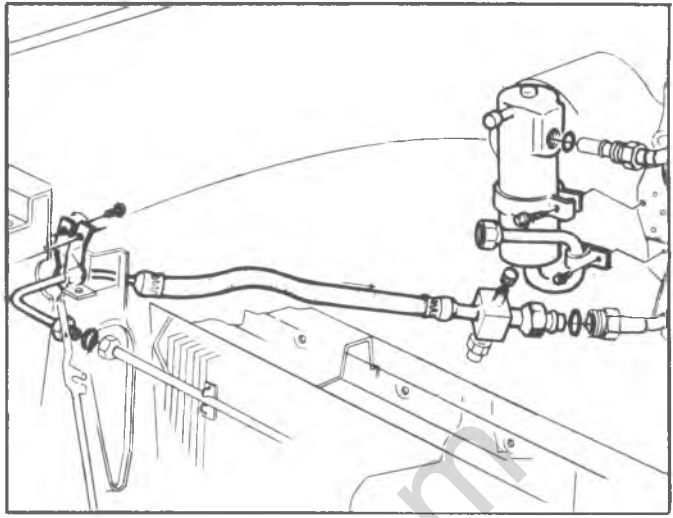

Fig. 59--Accumulator Installation (C-K Models)

## ACCUMULATOR

### Replacement (Fig. 59)

1. Disconnect the battery ground cable and the compressor clutch connector.
2. Purge the system of refrigerant.

**WARNING:** Be sure system is completely purged of refrigerant before completely disconnecting refrigerant lines. Visually check the accumulator for frost. The presence of frost indicates that the system is not fully discharged. To complete purging, connect the vacuum line to the vacuum pump, turn on the vacuum pump and open vacuum control valve. An alternate method would be to place warm water soaked cloths (not exceeding 125°F) around the accumulator to boil off any remaining refrigerant.

3. Disconnect the accumulator inlet and outlet lines and cap or plug the open connections at once.
4. Remove the accumulator bracket screws and remove the accumulator from the vehicle.
5. Drain any excess refrigerant oil from the accumulator into a clean container. Measure and discard the oil.
6. If a new accumulator is being installed, add one ounce of clean refrigeration oil to the new accumulator **PLUS** an amount equal to that drained in Step 5 above.

7. To install the new accumulator, reverse Steps 1-4 above. Connect all lines using new "O" rings, coated with clean refrigeration oil.

**CAUTION:** Do not uncap the new unit until ready to fasten the inlet and outlet line to the unit.

8. Evacuate charge and check the system.

## BLOWER ASSEMBLY

### Replacement

1. Disconnect the battery ground cable.
2. Disconnect the blower motor lead and ground wires.
3. Disconnect the blower motor cooling tube.
4. Remove the blower to case attaching screws and remove the blower assembly. Pry the blower flange away from the case carefully if the sealer acts as an adhesive.
5. Remove the nut attaching the blower wheel to the motor shaft and separate the assemblies.
6. To install, reverse Steps 1-5 above; replace sealer as necessary.

## EVAPORATOR CORE

### Replacement (Fig. 60)

1. Disconnect the battery ground cable.
2. Purge the system of refrigerant.

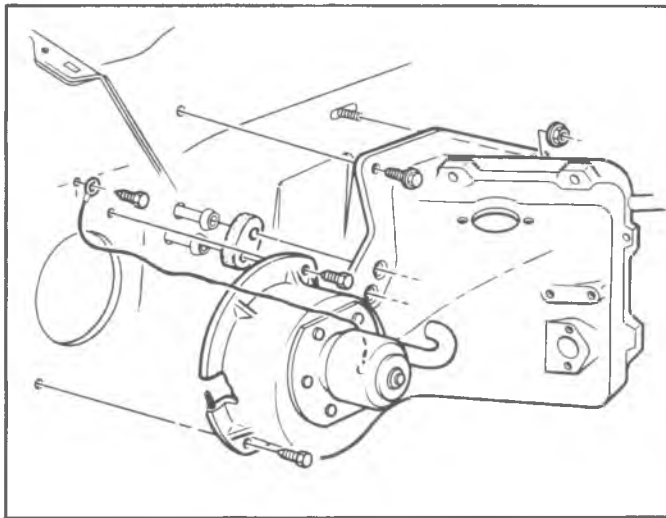

Fig. 60--Blower-Evaporator (C-K Models)

3. Remove the nuts from the selector duct studs projecting through the dash panel.
4. Remove the cover to dash and cover to case screws and remove the evaporator case cover.
5. Disconnect the evaporator core inlet and outlet lines and cap or plug all open connections at once.
6. Remove the thermostatic switch and the expansion tube assemblies.
7. Remove the evaporator core assembly.
8. To install, reverse Steps 1-7 above. Add three ounces of clean refrigeration oil to a new evaporator core.

**CAUTION:** Be sure to install the thermostatic switch capillary in the hole provided in the new core.

**NOTE:** Use new "O" rings, coated with clean refrigeration oil, when connecting refrigerant lines.

Be sure cover to case and dash panel sealer is intact before reinstalling cover.

9. Evacuate, charge and check the system.

## EXPANSION TUBE

The expansion tube is located in the evaporator core inlet line.

### Replacement (Fig. 61)

1. Purge the system of refrigerant.
2. Disconnect the condenser to evaporator line at the evaporator inlet. Cap the open line at once.
3. Using needle-nose pliers, remove the expansion tube from the evaporator core inlet line (fig. 61).

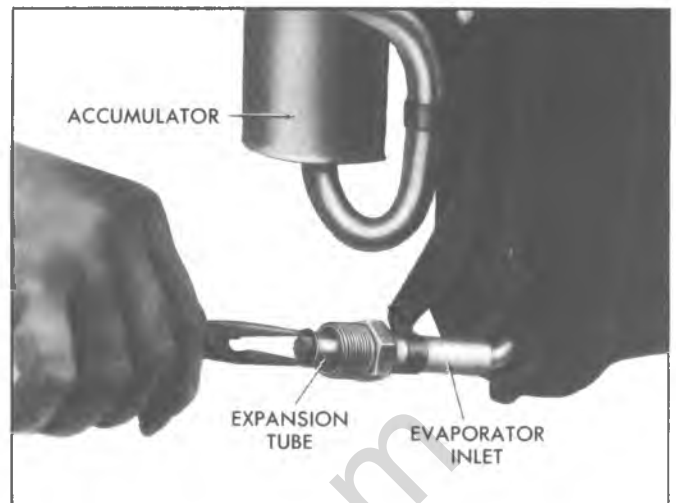

Fig. 61--Expansion Tube (C-K Four-Season System)

4. Remove the expansion tube "O" ring from the core inlet line.
5. To install, reverse Steps 1-4 above.

**NOTE:** Install the expansion tube using a new "O" ring, coated with clean refrigeration oil.

6. Evacuate, charge and check the system.

## SELECTOR DUCT AND HEATER CORE ASSEMBLY

### Replacement (Figs. 62 and 63)

1. Disconnect the battery ground cable.
2. Drain the radiator and remove the heater hoses from the core tubes. Plug the core tubes to prevent coolant spillage during removal.

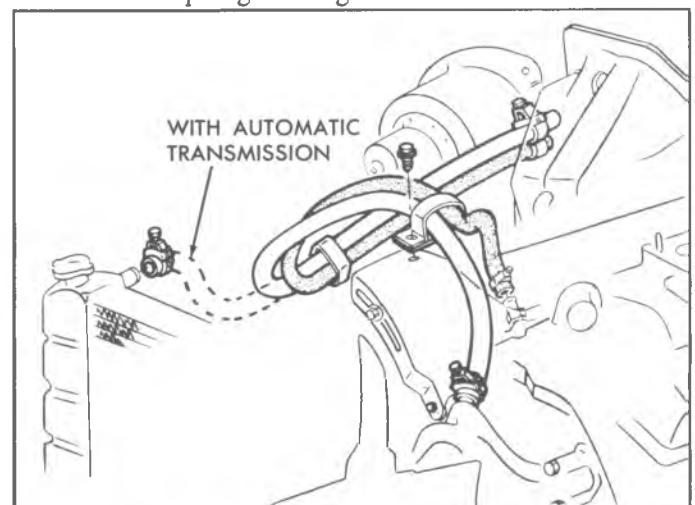

Fig. 62--Heater Hose Routings (C-K Models)

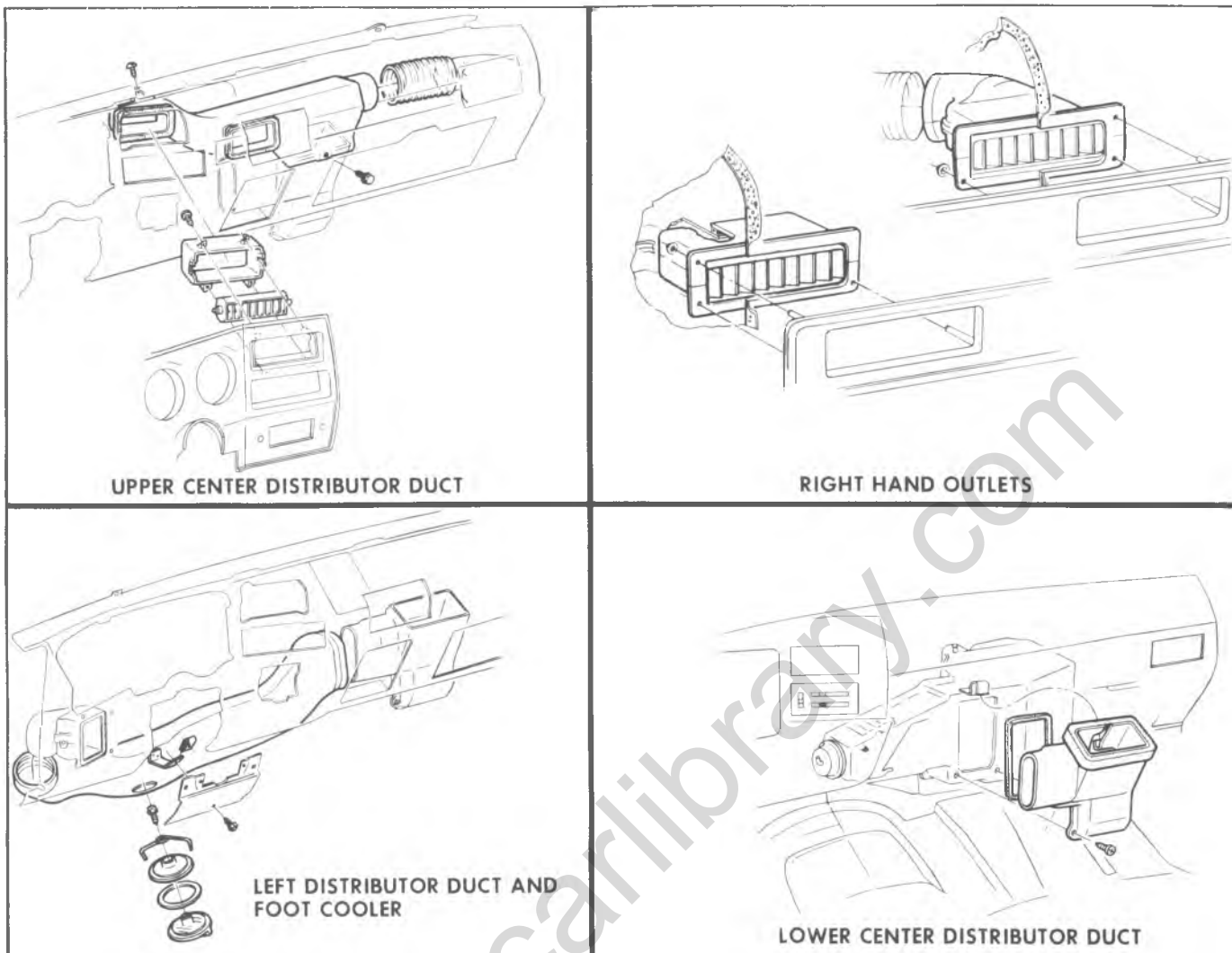

Fig. 63--Air Selector and Ducts (C-K Models)

3. Remove the glove box and door as an assembly.
4. Remove the center duct to selector duct and instrument panel screws and remove the center lower and center upper ducts.
5. Disconnect the bowden cable at the temperature door.
6. Remove the nuts from the three selector duct studs projecting through the dash panel.
7. Remove the selector duct to dash panel screw (inside vehicle).
8. Pull the selector duct assembly rearward until the core tubes clear the dash panel. Lower the selector assembly for enough to gain access to all vacuum and electrical harness.
9. Disconnect the vacuum and electrical harness and remove the selector duct assembly.
10. Remove the core mounting strap screws and remove the core.
11. To install, reverse Steps 1-10 above.

12. Refill coolant system and connect the battery ground strap. Check temperature door cable adjustment.

### KICK PAD VALVE

#### Replacement (Fig. 64)

1. Disconnect the vacuum hose at the actuator.
2. Unhook the valve return spring at the actuator end.
3. Remove the actuator bracket mounting screws.
4. Remove the cam to actuator arm screw and separate the actuator and bracket from the cam.
5. Remove the actuator to bracket nuts and separate the actuator and bracket.
6. To install reverse Steps 1-5 above.

### PLENUM VALVE

#### Replacement (Fig. 64)

1. Raise the hood.



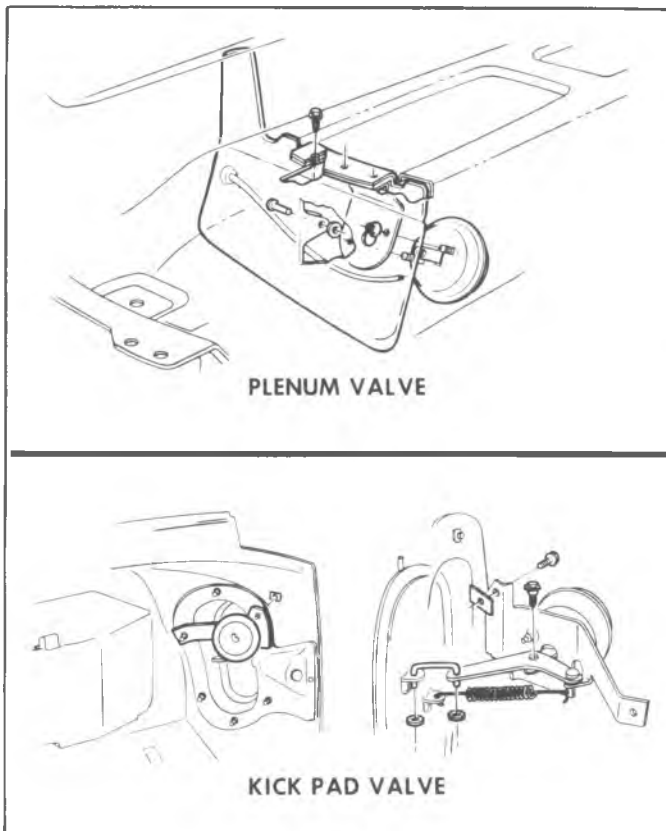

Fig. 64--Air Inlet Valves (C-K Models)

2. Remove the cowl plastic grille.
3. Remove the three cowl to valve assembly screws and remove the valve assembly from the vehicle.
4. Remove the actuator arm push nut.
5. Remove the actuator to valve nuts and separate the valve and actuator.
6. To install, reverse Steps 1-5 above.

### CONTROL ASSEMBLY

#### Removal (Fig. 65)

1. Disconnect the battery ground cable.
2. Remove the radio as outlined in Section 15 of this manual.
3. Remove the instrument panel bezel.
4. Remove the control to instrument panel screws and lower the control far enough to gain access to the control assembly.

**CAUTION:** Be careful not to kink the bowden cable.

5. Disconnect the bowden cable, vacuum harness and electrical harness at the control.
6. Remove the control.

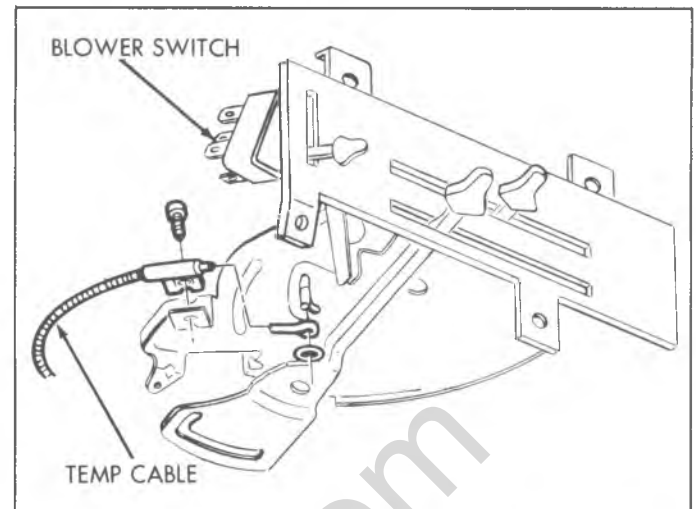

Fig. 65--Control Assembly (C-K Four-Season System)

7. If a new unit is being installed, transfer the master and blower switches to the new control.
8. To reinstall, reverse Steps 1-6 above. Check control operation.

### TEMPERATURE DOOR CABLE ADJUSTMENT

1. Remove glove box and door assembly.
2. Loosen the cable attaching screw at the selector duct assembly.
3. Make sure the cable is installed in the bracket on the selector duct assembly.
4. Place temperature lever in full COLD position and hold while tightening cable attaching screw.

### MASTER SWITCH AND/OR BLOWER SWITCH

The master switch is located on rear of the control assembly.

#### Replacement

1. Disconnect the battery ground cable.
2. Remove the instrument panel bezel.
3. Remove the control to instrument panel screws and allow control to rest on top of the radio.
4. Remove the switch to control screws, disconnect the electrical harness (and vacuum harness on master switch) at the switch and remove the switch assembly.
5. To install a new switch, reverse Steps 1-4 above.

### VACUUM TANK

The vacuum tank is mounted to the engine side of the dash panel above the blower assembly (fig. 66).

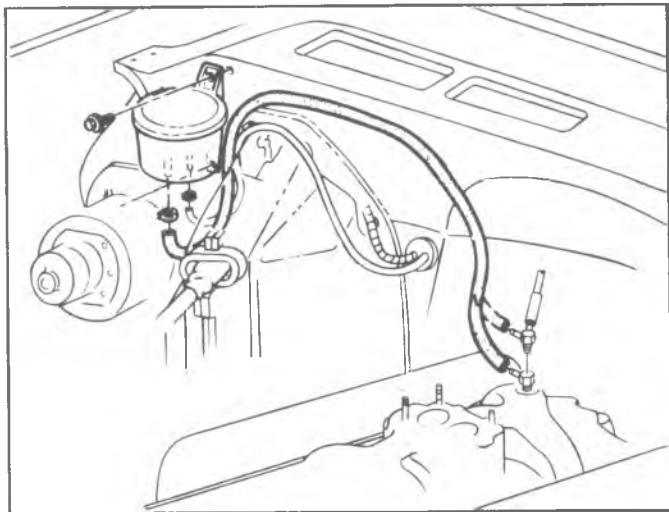

Fig. 66--Vacuum Tank (C-K Models)

**Replacement**

1. Disconnect the vacuum lines at the tank.
2. Remove the tank to dash panel screws and remove the tank.
3. To install, reverse Steps 1 and 2 above.

**BLOWER MOTOR RESISTOR**

The blower motor resistor is located in the blower side of the blower-evaporator case (fig. 67).

**Replacement**

1. Disconnect the wiring harness at the resistor.

2. Remove the resistor to case attaching screws and remove the resistor.
3. Place the new resistor in position and install the attaching screws.
4. Connect the resistor wiring harness.

**BLOWER MOTOR RELAY**

The blower motor relay is located on the blower side of the blower-evaporator case (fig. 67).

**Replacement**

1. Disconnect the wiring harness at the relay.
2. Remove the relay to case attaching screws and remove the relay.
3. Place the new relay in position and drive the mounting screws.
4. Connect the relay wiring harness.

**THERMOSTATIC SWITCH**

The thermostatic switch is mounted to the blower side of the blower-evaporator case. The switch sensing capillary extends into the evaporator core (fig. 68).

**Replacement**

1. Disconnect the battery ground strap.
2. Disconnect the wiring harness at the switch.
3. Remove the switch to case screws and remove the switch carefully so as not to damage the capillary tube.

NOTE: Note capillary tube position in the core so that the capillary may be reinstalled in the same position (fig. 68).

4. Place the new switch in position, installing the capillary in the core in the same manner as at switch removal.

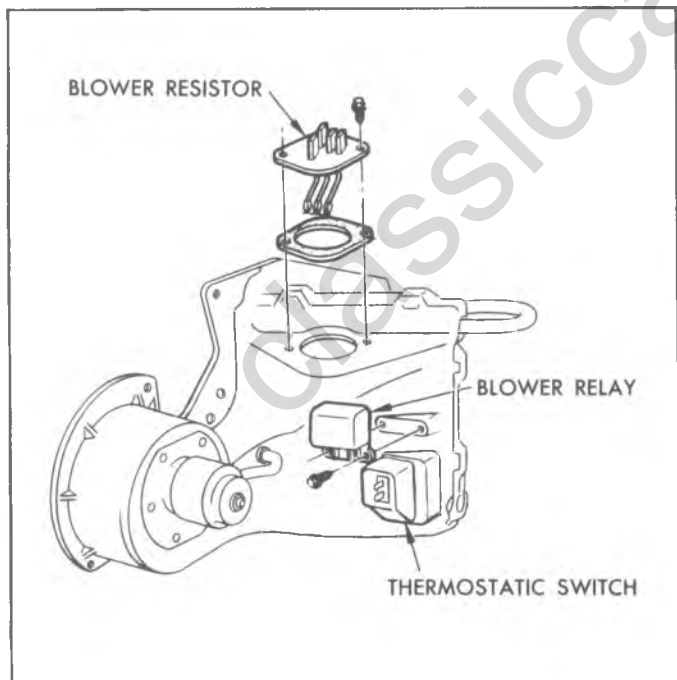

Fig. 67--Resistor, Relay and Thermostatic Switch (C-K Models)

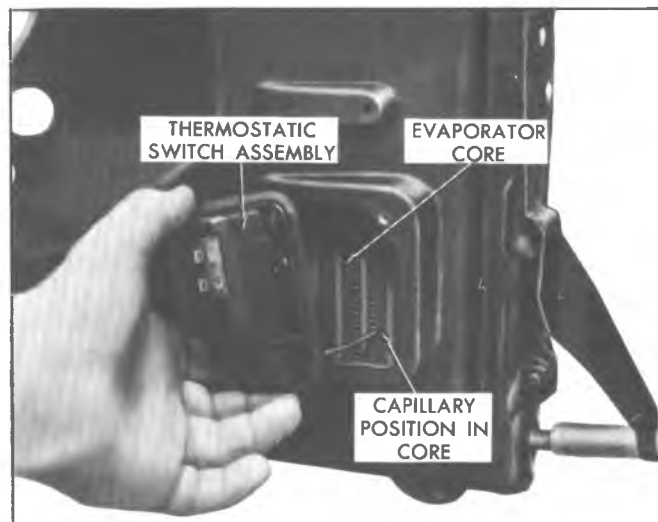

Fig. 68--Replacing Thermostatic Switch

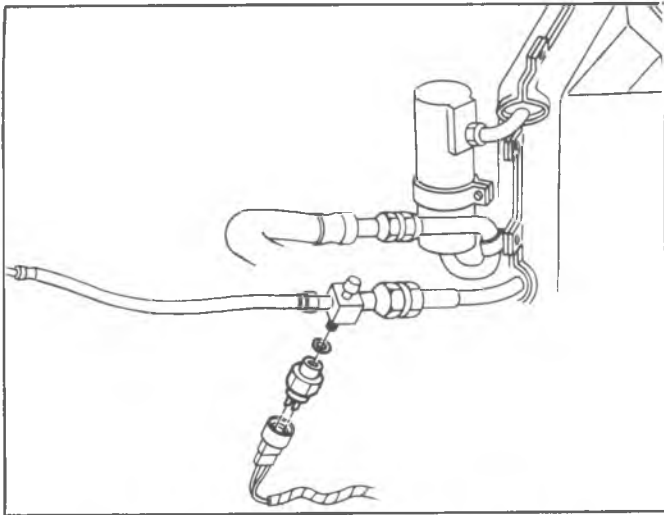

Fig. 69--Discharge Pressure Switch (C-K Models)

5. Drive the switch mounting screws, connect the wiring harness and the battery ground strap.

### DISCHARGE PRESSURE SWITCH

The discharge pressure switch is located in the condenser

to evaporator line (fig. 69).

### Replacement

1. Disconnect the battery ground cable.
2. Purge the system of refrigerant.
3. Disconnect the wiring harness at the switch.
4. Remove the switch from the refrigerant line.
5. To replace, reverse Steps 1-4 above.

NOTE: Be sure to use new "O" rings, coated with clean refrigeration oil, when installing the switch.

6. Evacuate charge and check system operation.

### FUSE

A 25 amp fuse, located in the junction block protects the entire air conditioning system except for the blower when operating at HI.

A 30 amp fuse, to protect the HI speed blower circuit, is located in the electrical wiring between the junction block and the blower relay (fig. 70).

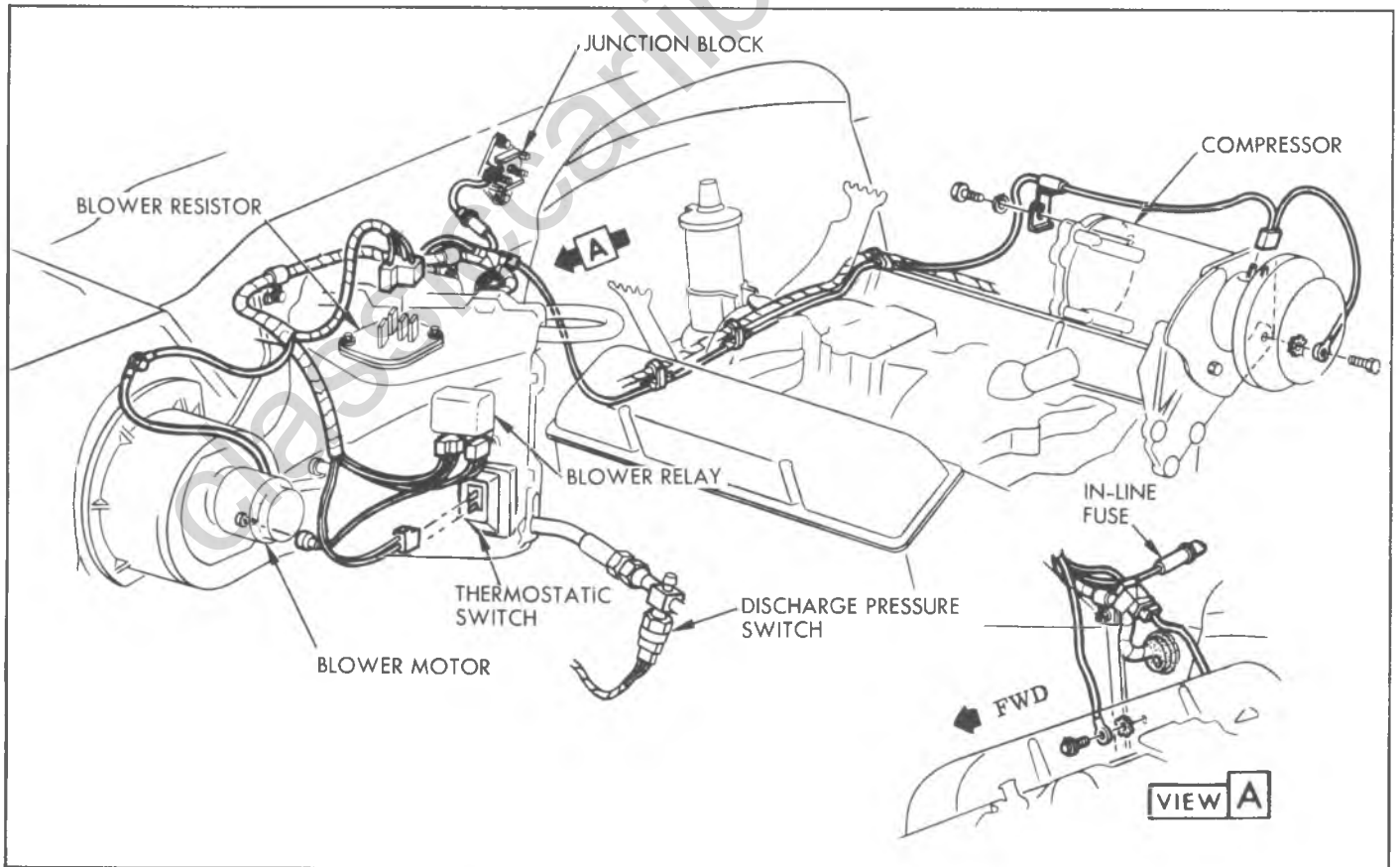

Fig. 70--Engine Compartment Wiring Harness (C-K Models)

## COMPONENT PART REPLACEMENT

### OVERHEAD SYSTEM--C-K MODELS

The Overhead System is used in conjunction with the Four-Season System. Since replacement of Four-Season System components has been covered previously, only those components peculiar to the Overhead System will be covered in this section.

#### REAR DUCT

This duct covers the blower-evaporator assembly, at the rear of the vehicle, and incorporates four adjustable air outlets (fig. 71).

#### Replacement

1. Disconnect the battery ground cable.
2. Disconnect the drain tube from the rear duct.
3. Remove the screws securing the duct to the roof panel and rear header brackets.
4. Remove the duct.
5. To install, reverse Steps 1-4 above.

#### BLOWER MOTOR RESISTOR

The blower motor resistor is located on the cover side of the Four-Season System blower-evaporator as shown in Figure 72.

#### Replacement

1. Disconnect battery ground cable.

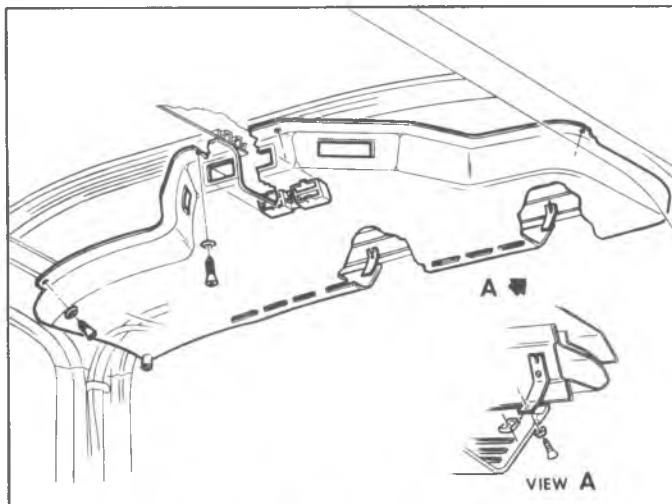

Fig. 71--Rear Duct (C-K Overhead System)

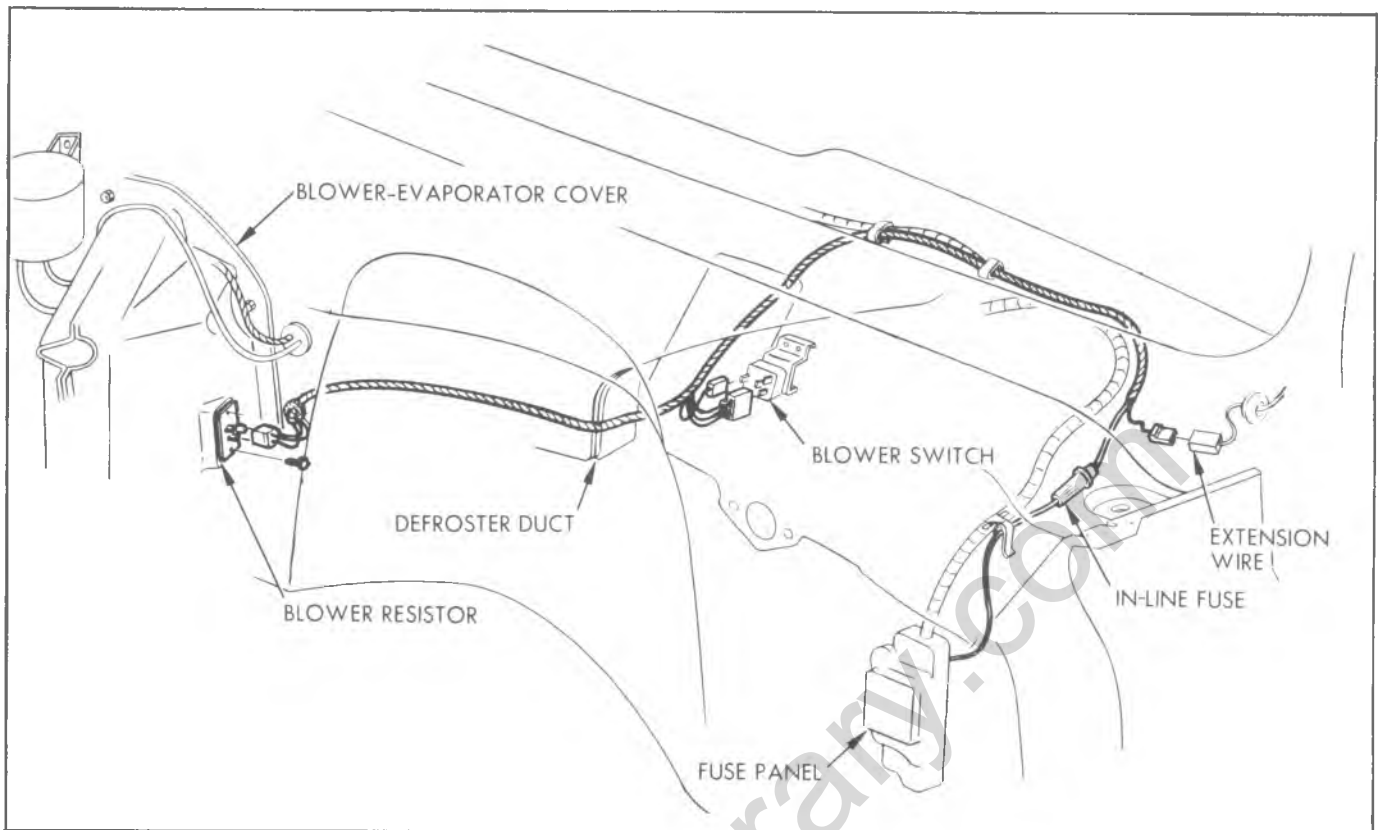

Fig. 72--Overhead System Front Wiring (C-K Models)

2. Disconnect the electrical harness at the resistor.
3. Remove the resistor attaching screws and remove the resistor.
4. To install a new resistor, reverse Steps 1-3 above.
2. Remove the rear duct as outlined previously.
3. Disconnect the blower motor ground strap.
4. Disconnect the blower motor lead wire.
5. Remove the lower to upper blower-evaporator case screws and lower the lower case and motor assembly.

## BLOWER MOTOR ASSEMBLY

### Removal (Fig. 73)

1. Disconnect the battery ground cable.

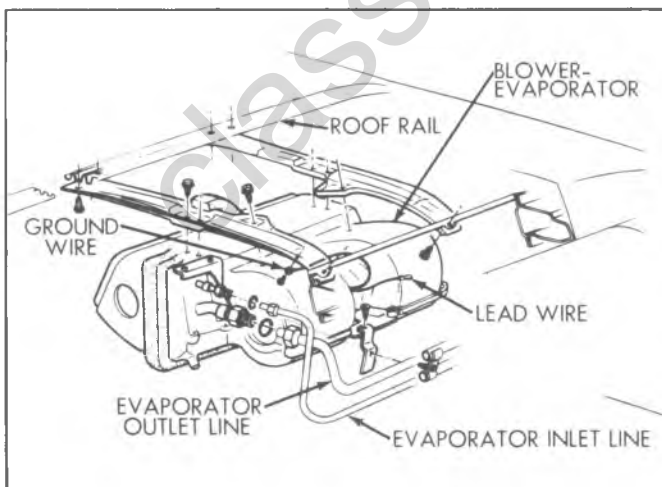

Fig. 73--Blower-Evaporator (C-K Overhead System)

**CAUTION:** Before removing the case screws, support the lower case to prevent damage to the case or motor assemblies.

6. Remove the motor retaining strap and remove the motor and wheels. Remove the wheels from the motor shaft.

### Installation

1. Place the blower wheels onto the motor shaft making sure the wheel tension springs are installed on hub of wheels.

**CAUTION:** Be sure that the blower wheels are installed as shown in Figure 74.

2. Install the blower motor retaining strap and foam.
3. Place the blower motor and wheel assembly into the lower case. Align the blower wheels so that they do not contact the case.
4. Place the lower case and blower motor assembly in

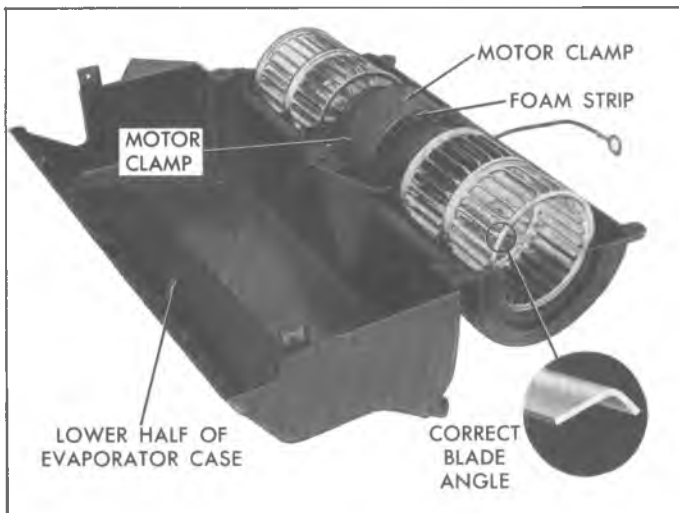

Fig. 74-Blower Motor (C-K Overhead System)

position in the vehicle and install the lower to upper case screws.

**NOTE:** Rotate the blower wheels to make sure that they do not rub on the case.

5. Install the center ground wire and connect the blower lead wire.
6. Install the rear duct assembly as described previously.
7. Connect the battery ground cable.

### EXPANSION VALVE

This system incorporates an expansion valve which does not utilize an external equalizer line (fig. 75).

#### Removal

1. Disconnect the battery ground cable.
2. Purge the system of refrigerant.
3. Remove the rear duct as outlined previously.
4. Disconnect the blower motor lead and ground wires.
5. Remove the lower to upper blower-evaporator case screws and lower the lower case and motor assembly.

**CAUTION:** Before removing the case screws, support the lower case and motor assemblies.

6. Remove the expansion valve sensing bulb clamps.
7. Disconnect the valve inlet and outlet lines and remove the expansion valve assembly. Cap or plug the open connections at once.

#### Installation

1. Remove caps or plugs from system connections and install the new valve assembly using new "O" rings coated with clean refrigeration oil.

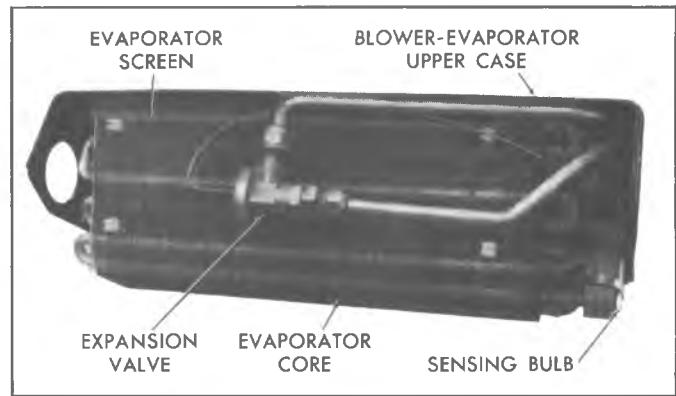

Fig. 75-Expansion Valve (C-K Overhead System)

2. Install the sensing bulb, making sure that the bulb makes good contact with the core outlet line.
3. Install the lower case and blower motor assemblies. Connect the blower motor lead and ground wires.
4. Install the rear duct as outlined previously.
5. Connect the battery ground cable.
6. Evacuate, charge and check the system.

### EVAPORATOR CORE (Fig. 75)

#### Removal

1. Disconnect the battery ground cable.
2. Purge the system of refrigerant.
3. Remove the rear duct as outlined previously.
4. Disconnect the blower motor lead and ground wire connections.
5. Disconnect the refrigerant lines at the rear of the blower-evaporator assembly. Cap or plug the open connections at once.
6. Remove the blower-evaporator support to roof rail screws, lower the blower-evaporator assembly and place it on a work bench upside down.
7. Remove the lower to upper case screws and remove the lower case assembly. Remove the support to upper case screws and remove the upper case from the evaporator core.
8. Remove the expansion valve inlet and outlet lines and cap or plug the open connections at once. Remove the expansion valve capillary bulb from the evaporator outlet line and remove the valve.
9. Remove the plastic pins holding the screen to the core and remove the screen.

#### Installation

1. Install the wire screen to the front of the core and insert the plastic pins.
2. Install the expansion valve inlet and outlet lines using new "O" rings coated with clean refrigeration oil. Install the sensing bulb to the evaporator outlet

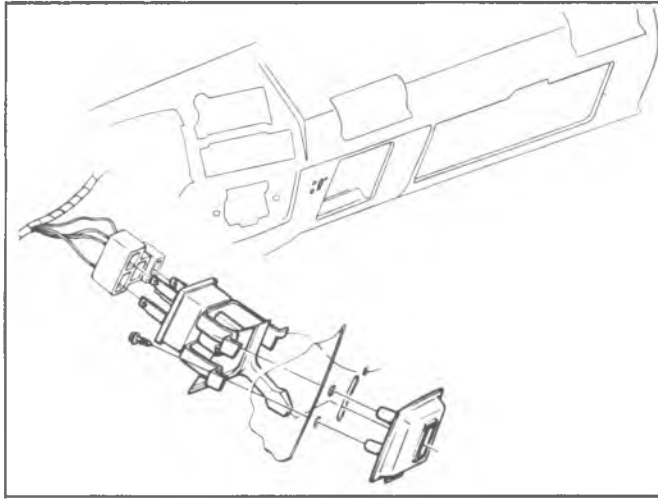

Fig. 76--Blower Switch (C-K Overhead System)

line as shown in Figure 75; make sure the bulb has good contact with the line.

**NOTE:** Add 3 oz. clean refrigeration oil when installing a new core.

3. Install the upper case and supports to the core.
4. Install the lower core case and blower assembly.
5. Install the blower-evaporator assembly to the roof and install the support to roof rail screws.

6. Connect the refrigerant lines to the blower-evaporator unit using new "O" rings coated with clean refrigeration oil.
7. Connect the blower lead and ground wires.
8. Install the rear duct as outlined previously.
9. Connect the battery ground cable.
10. Evacuate, charge and check the system.

### BLOWER MOTOR SWITCH

The three-speed (LO-MED-HI) blower motor switch is located in the instrument panel, just to the left of the ash tray (fig. 76).

#### Replacement

1. Disconnect the battery ground cable.
2. Remove the switch retaining screws.
3. Disconnect the wiring harness at the switch and remove the switch.
4. To install, reverse Steps 1-3 above.

### FUSE

The Four Season portion of this system is protected by a 25 amp fuse in the junction block.

The rear blower high speed circuit is protected by a 20 amp in-line fuse, located between the junction block and the rear blower motor switch.

## COMPONENT PART REPLACEMENT C60 SYSTEM--G MODELS

### CONDENSER

#### Replacement (Fig. 77)

1. Remove the battery ground cable and compressor

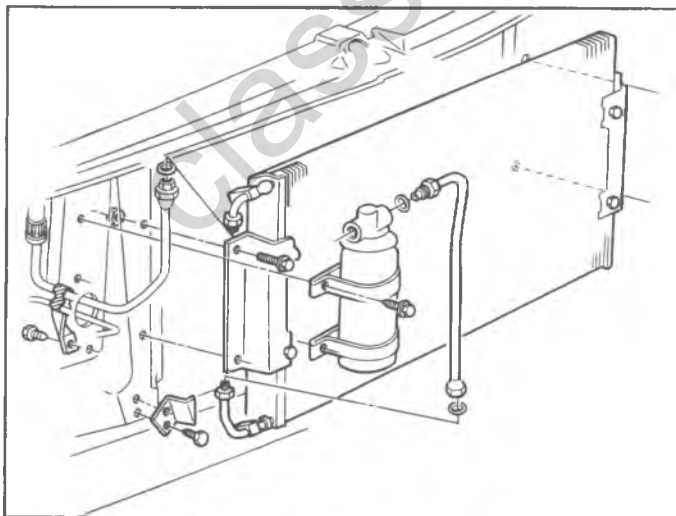

Fig. 77--Condenser (G Models)

- clutch connector.
2. Purge the system of refrigerant.
3. Remove the left and right hand headlamp bezels and parking lamp lens. Place a piece of protective tape over upper surface of the front bumper. Remove the grille to radiator support screws and remove the grille.
4. Remove the screws from radiator center brace and remove the brace.
5. Remove the upper radiator supports. Move the upper edge of the radiator rearward to gain access to condenser attachment.
6. Remove the condenser to radiator support nuts and bolts.
7. Disconnect the condenser inlet and outlet lines and remove the condenser. Cap or plug the open connections at once.
8. Remove the condenser mounting brackets from the condenser.
9. To install, reverse Steps 1-8 above. Add 1 fluid ounce of clean refrigeration oil to a new condenser.

**CAUTION:** Use new "O" rings, coated with

## 1A-72 HEATER AND AIR CONDITIONING

*clean refrigeration oil, when connecting all refrigerant lines.*

10. Evacuate, charge and check the system.

### RECEIVER-DEHYDRATOR

#### Replacement (Fig. 77)

1. Disconnect the battery ground cable, and the compressor clutch connector.
2. Purge the system of refrigerant.
3. Remove left and right hand headlamp bezel and parking lamp lens. Place a piece of protective tape over the upper surface of the front bumper. Remove the grille to radiator support screws and remove the grille.
4. Disconnect the receiver-dehydrator inlet and outlet lines and cap or plug the connections at once.
5. Remove the receiver-dehydrator bracket attaching screws.
6. Remove the receiver-dehydrator from the vehicle.
7. If a new receiver-dehydrator is being installed, add 1 fluid ounce of clean refrigeration oil to the new unit.
8. Connect the inlet and outlet lines using new "O" rings coated with clean refrigeration oil.  
**CAUTION:** Do not uncap the new unit until ready to fasten the inlet and outlet lines to the unit.
9. Install receiver-dehydrator by reversing Steps 1-6 above.
10. Evacuate, charge and check the system.

### SIGHT GLASS REPLACEMENT

If damage to the sight glass should occur, a new sight glass kit should be installed. The kit contains the sight glass, seal and retainer. (See Figure 78).

1. Purge system.
2. Remove the sight glass retainer nut using a screwdriver and remove old glass and "O" ring seal.
3. Install the new glass and seal and retainer nut, being careful not to turn the nut past the face of the housing. To do so may damage the "O" ring seal.
4. Evacuate, charge and check the system.

### A/C AIR DISTRIBUTOR DUCT

#### Replacement (Fig. 79)

1. Disconnect the battery ground cable.

2. Remove screws securing the blower-evaporator shield; remove the shield. Remove the shield bracket to instrument panel reinforcement screws and remove the bracket.
3. Remove the heater intermediate duct to A/C distributor duct screw and remove the duct.
4. Unsnap the engine cover latches, remove the lower tab mounting bolts and remove the engine cover.
5. Loosen both steering column instrument panel reinforcement screws; remove one screw.
6. Remove the left foot cooler bracket to instrument panel reinforcement screws, disconnect the outlet from the duct and remove the outlet and bracket assembly.
7. Disconnect the speedometer cable.
8. Remove the instrument panel to lower reinforcement attaching screws. Rotate the instrument panel up to gain access to the air distribution duct.
9. Disconnect the blower resistor electrical harness.
10. Remove the duct to instrument panel attaching screws and remove the duct assembly.
11. If a new duct is being installed, transfer the blower resistor to the new duct. Reverse Steps 1-10 above.

**NOTE:** Make sure all ducts and seals are installed properly.

### A/C CENTER AND RIGHT DASH OUTLETS

#### Replacement (Fig. 79)

1. Follow Steps 1-10 of "A/C Air Distributor Duct-Replacement".
2. Remove the outlet to instrument panel screws and remove the outlet.
3. To install, reverse Steps 1-2 above.

### A/C LEFT DASH OUTLET

#### Replacement (Fig. 79)

1. Follow Steps 1-8 of "A/C Air Distributor Duct-Replacement".
2. Remove the outlet to instrument panel screws and remove the outlet.
3. To install, reverse Steps 1-2 above.

### HEATER AIR DISTRIBUTOR AND EXTENSION DUCTS

#### Replacement (Fig. 79)

1. Purge the system of refrigerant.
2. Follow Steps 1-8 of "A/C Air Distributor Duct-Replacement".
3. Disconnect the evaporator inlet and outlet lines. Cap or plug all open connections at once.
4. Remove the blower-evaporator support bracket to



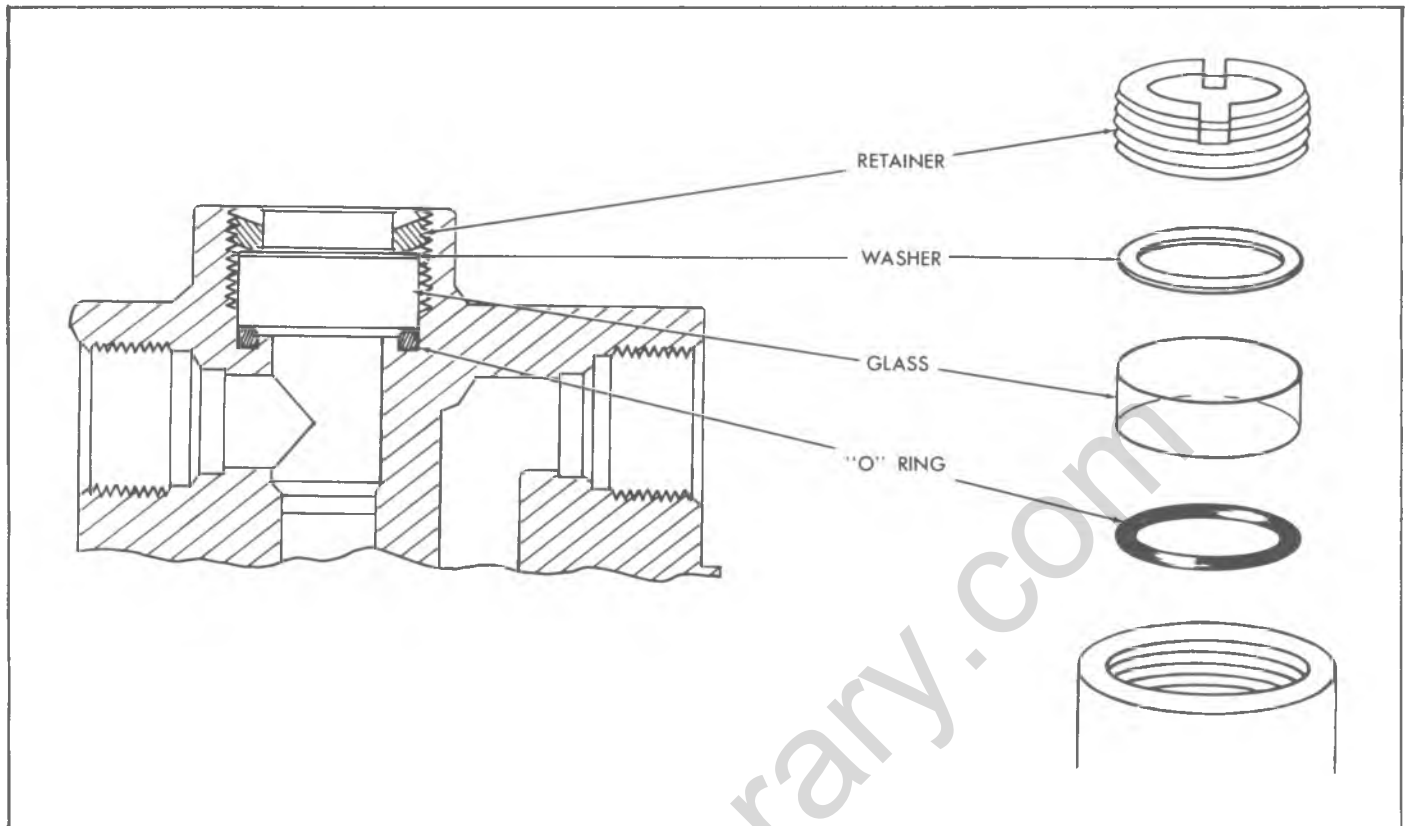

Fig. 78-Sight Glass Replacement

door pillar and forward engine housing screws and lower the blower-evaporator assembly. Disconnect electrical connections, pull evaporator drain hose through the dash panel, and remove the blower-evaporator assembly.

5. Remove the left floor outlet duct attaching screw and remove the duct.
6. Disconnect the vacuum hoses and electrical harness tabs. Remove the air distributor duct attaching screws and remove the duct assembly.
7. To install, reverse Steps 1-6 above.
8. Evacuate, charge and check system operation.

### HEATER CORE CASE AND CORE Replacement (Fig. 79)

1. Purge the system of refrigerant.
2. Place a pan under the vehicle. Disconnect the heater hoses at the core tubes and drain the engine coolant into the pan. Plug the core tubes to prevent coolant spillage at core removal.
3. Follow Steps 1-8 of "A/C Air Distributor Duct-Replacement".
4. Disconnect the evaporator inlet and outlet lines. Cap or plug all open connections at once.
5. Remove the blower-evaporator support bracket to door pillar and forward engine housing screws and

lower the blower-evaporator assembly. Disconnect electrical connections, pull evaporator drain hose through the dash panel and then remove the blower-evaporator as an assembly.

6. Remove the temperature door cable eyelet clip and then remove the bowden cable attaching screw.
  7. Remove the heater distributor duct to case screws and pull the duct rearward out of the heater case retainer.
  8. Remove the heater core case to dash screws and then remove the heater case and core as an assembly. Tilt the case rearward at the top while lifting up until the core tubes clear dash openings.
  9. Remove the core retaining straps and remove the core.
  10. To install a new core, reverse Steps 1-9 above. Use new "O" rings coated with clean refrigeration oil, when connecting refrigerant lines.
- NOTE: Be sure core to case and case to dash panel sealer is intact before assembling unit.
11. Refill cooling system to proper level.
  12. Evacuate, charge and check system operation.

### EXPANSION VALVE

#### Replacement (Fig. 80)

1. Purge the system of refrigerant.

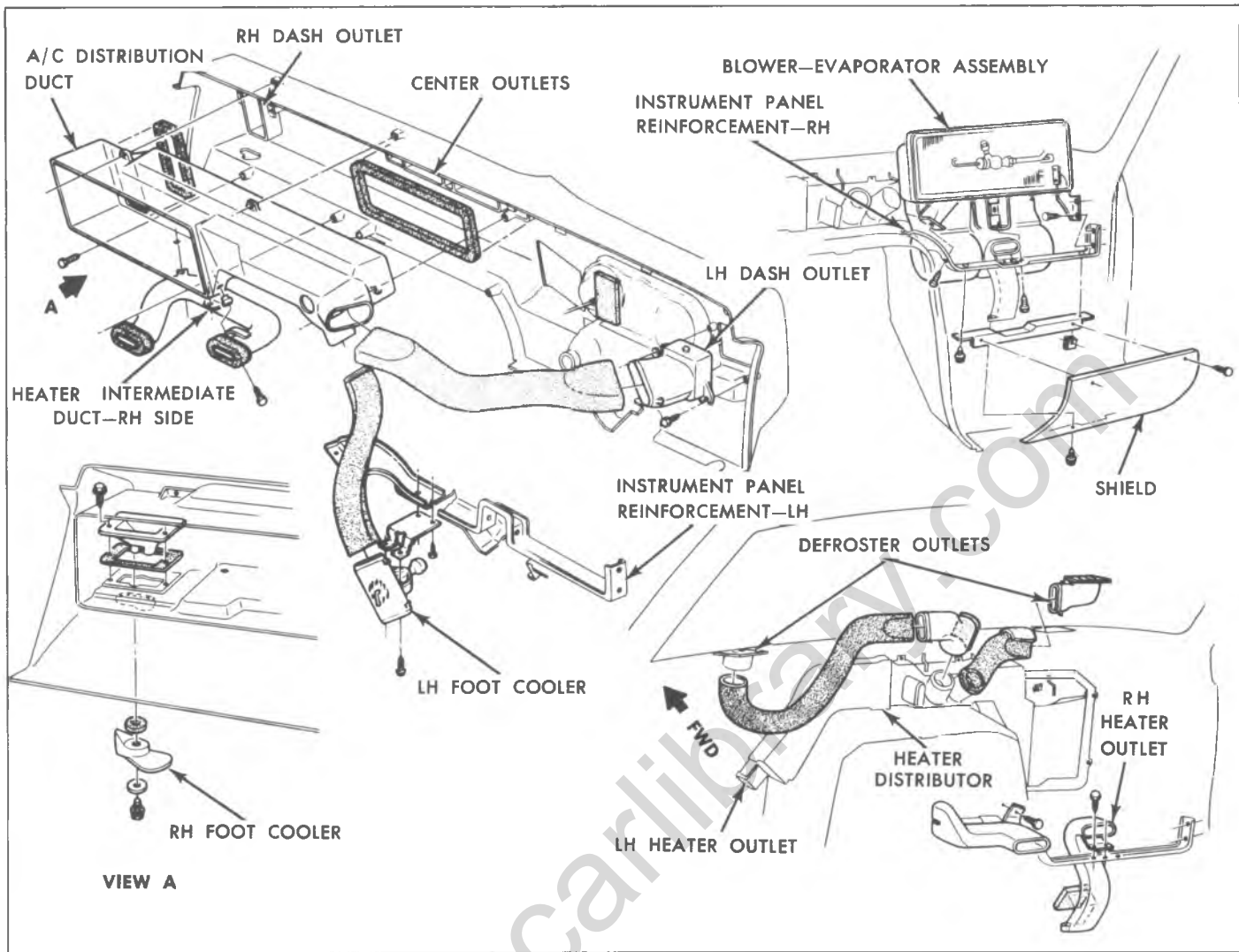

Fig. 79--Air Distributor Ducts (C60 System - G Models)

2. Follow Steps 1-8 of "A/C Air Distributor Duct- Replacement".
3. Loosen the expansion valve sensing bulb clamps and remove the bulb from the evaporator core.
4. Disconnect the expansion valve inlet and outlet lines and remove the expansion valve assembly. Cap or plug all open connections at once.
5. To install a new expansion valve, reverse Steps 1-4 above.

NOTE: Use new "O" rings, coated with clean refrigeration oil when connecting all lines.

Make sure expansion valve sensing bulb makes good physical contact with the evaporator core connector block.

6. Evacuate, charge and check system operation.

## A/C BLOWER MOTOR

### Replacement (Fig. 80)

1. Purge the system of refrigerant.
2. Follow Steps 1-8 of "A/C Air Distributor Duct- Replacement".
3. Disconnect evaporator inlet and outlet lines. Cap or plug open connections at once.
4. Remove the blower-evaporator support bracket to door pillar and forward engine housing screws and lower the blower-evaporator assembly. Disconnect electrical connections, pull drain hose through the dash panel and remove the blower-evaporator as an assembly.
5. Separate the front and rear case halves.
6. Remove the blower motor retaining strap and insulator strip and remove the motor and blower wheels as an assembly.

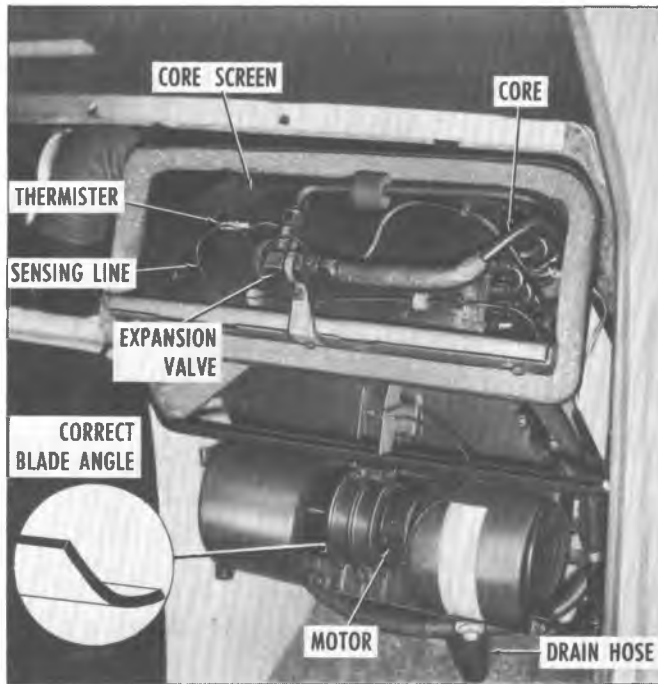

Fig. 80--Blower and Evaporator (C60 System - G Models)

7. Mark the blower wheel locations (L and R) and then remove the blower wheels from the motor shaft.
8. To reinstall, reverse Steps 1-7 above.

NOTE: Install blower wheels in proper position (L and R) as marked at removal (blade angle as shown in Figure 80). Be sure to install insulation around motor before installing motor clamp. Check blower operation that wheels do not rub on case.

When making evaporator core connections, use new "O" rings coated with clean refrigeration oil.

9. Evacuate, charge and check system operation.

## EVAPORATOR CORE

### Replacement (Fig. 80)

1. Purge the system of refrigerant.
2. Follow Steps 1-8 of "A/C Air Distributor Duct-Replacement".
3. Disconnect evaporator inlet and outlet connections. Cap or plug open connections at once.
4. Remove the blower-evaporator support bracket to door pillar and forward engine housing screws and lower the blower-evaporator assembly. Disconnect the electrical connections, pull drain hose through the dash panel and remove the blower-evaporator as an assembly.
5. Remove the expansion valve sensing bulb clamps

and disconnect the line from the evaporator core. Disconnect the expansion valve inlet and outlet lines and remove the expansion valve. Cap or plug all open connections at once.

6. Remove the evaporator core line clamp screws. Remove the core to case attaching screws and remove the evaporator core assembly.
7. To install a new core, reverse Steps 1-6 above. Transfer the core screen to the new core. NOTE: Add three ounces of new refrigeration oil to a new core. Use new "O" rings, coated with clean refrigeration oil, when connecting all refrigerant lines. Transfer thermister to the new evaporator.

NOTE: Make sure the expansion valve sensing bulb makes good contact with the core connector block.

8. Evacuate, charge and check system operation.

## AIR INLET VALVE

### Replacement (Fig. 81)

1. Purge the system of refrigerant.
2. Follow Steps 1-8 of "A/C Air Distributor Duct-Replacement".
3. Disconnect evaporator inlet and outlet lines. Cap or plug all open connections at once.
4. Remove the blower-evaporator support bracket to door pillar and forward engine housing screws and lower the blower-evaporator assembly. Disconnect electrical connections, pull drain hose through dash panel and remove the blower-evaporator as an assembly.
5. Disconnect vacuum hose at actuator.
6. Remove valve assembly to plenum attaching screws and remove assembly. Remove actuator.
7. To install, reverse Steps 1-6 above.

NOTE: When making refrigerant line

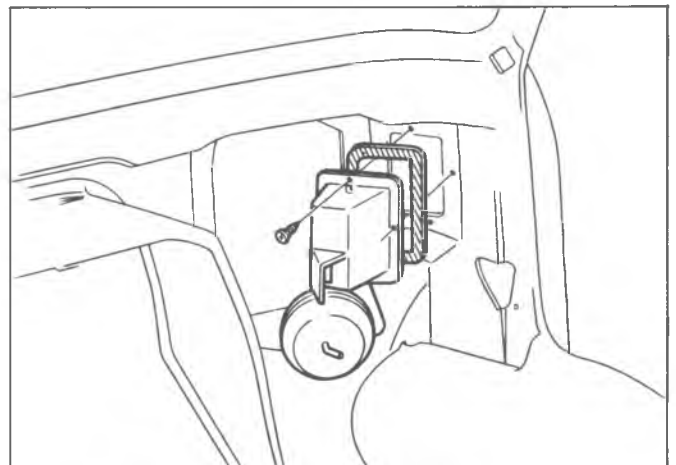

Fig. 81--Air Inlet Valve (G Model C60 System)

## 1A-76 HEATER AND AIR CONDITIONING

connections, use new "O" rings coated with clean refrigeration oil.

### TEMPERATURE DOOR CABLE

#### Replacement

1. Purge the system of refrigerant.
2. Follow Steps 1-8 of "A/C Air Distributor Duct-Replacement".
3. Disconnect evaporator inlet and outlet lines. Cap or plug all open connections at once.
4. Remove the blower-evaporator support bracket to door pillar and forward engine housing screws and lower the blower-evaporator assembly. Disconnect electrical connections, pull drain hose through dash panel and remove the blower-evaporator as an assembly.
5. Remove the cable retaining clip at the control end and remove the cable attaching screw.
6. Remove the cable clip and attaching screw at the door end of cable. Attach a 4' piece of wire to the cable and then remove the cable assembly. Disconnect the wire from the cable.
7. To install a new cable, reverse Steps 1-6 above. Check cable adjustment.

#### Adjustment

1. Disconnect the battery ground cable.
2. Pry off the cable eyelet clip at the control end. Remove the cable attaching screw.
3. While holding the cable with pliers, rotate the mounting tab on the cable to lengthen or shorten the cable as desired.  
  
**NOTE:** Do not pinch the cable too tightly or damage to the cable could result.
4. Install the cable to the control lever and install eyelet clip. Install the mounting tab screw. Check cable operation.
5. Connect the battery ground cable.

### CONTROL

#### Replacement (Fig. 82)

1. Disconnect the battery ground cable.
2. Remove the headlamp switch control knob.
3. Remove the instrument panel bezel.
4. Remove the control to instrument panel attaching screws.
5. Remove the temperature cable eyelet clip and mounting tab screw.
6. Pull the control through the instrument panel opening as follows: First pull the lower right

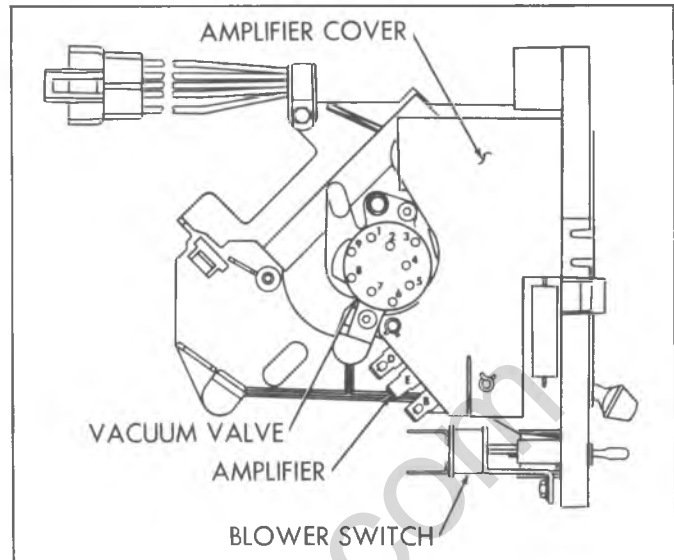

Fig. 82--Control (G Model C60 System)

mounting tab through the opening, then the upper tab and finally the lower right tab.

7. Disconnect electrical and vacuum connections and remove the control assembly.
8. To install, reverse Steps 1-7 above. Check temperature door operation; adjust if necessary.

### BLOWER SWITCH

#### Replacement (Fig. 82)

1. Disconnect the battery ground cable.
2. Remove the left foot cooler outlet assembly at the instrument panel attachment.
3. Disconnect the switch electrical harness.
4. Remove the switch mounting screws and remove the switch.
5. To install, reverse Steps 1-4 above.

### AMPLIFIER CIRCUIT BOARD

#### Replacement (Fig. 82)

1. Remove the control assembly as outlined under "Control-Replacement".
2. Remove the potentiometer gear from the pot shaft.
3. Remove amplifier board cover retainers and lay the cover back.
4. Remove the circuit board attaching screws and remove the circuit board and pot assembly.
5. To install, reverse Steps 1 and 4 above.

### RESISTORS

The heater blower motor resistor is mounted in the right hand plenum (in the same position as without air

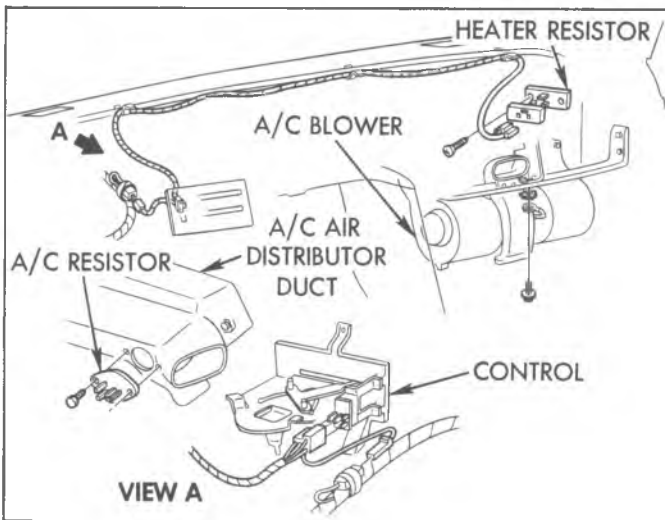

Fig. 83-Resistors (G Model C60 System)

conditioning). The A/C blower motor resistor is mounted in the forward face of the A/C air distribution duct (fig. 83).

**Replacement**

1. Follow Steps 1-8 of "A/C Air Distributor Duct- Replacement".
2. Disconnect electrical harness at the resistor.
3. Remove the resistor mounting screws and remove the resistor.
4. To install, reverse Steps 1-3 above.

**BLOWER MOTOR RELAY**

The blower motor relay is attached to the left end of the heater air distributor duct (fig. 84).

**Replacement**

1. Follow Steps 1-8 of "A/C Air Distributor Duct- Replacement".

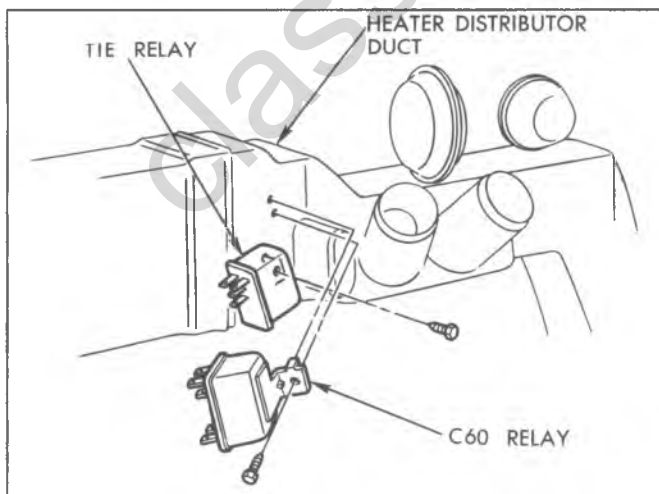

Fig. 84-Relays (C60 and Tie Relay with C69)

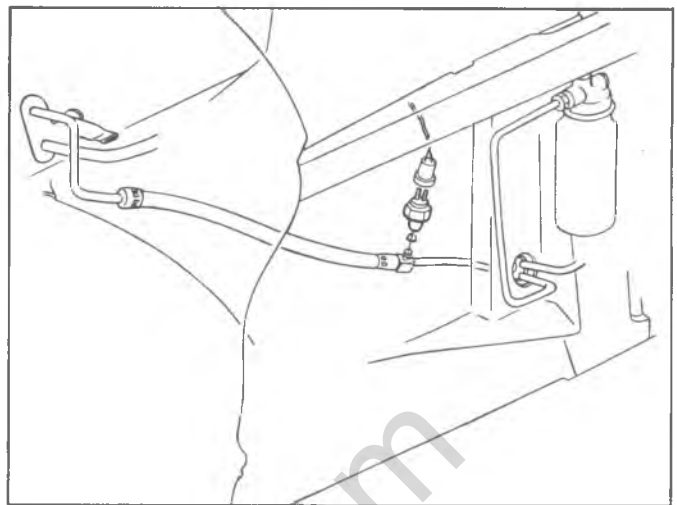

Fig. 85-Discharge Pressure Switch (G Models)

2. Disconnect electrical harness at the relay.
3. Remove the relay mounting screw and remove the relay.
4. To install, reverse Steps 1-3 above.

**DISCHARGE PRESSURE SWITCH**

**Replacement (Fig. 85)**

1. Raise the hood.
2. Purge the system of refrigerant.
3. Disconnect the electrical harness at the switch.
4. Remove the switch from the refrigerant line.
5. To install, reverse Steps 1-4 above.

NOTE: Use a new "O" ring coated with clean refrigeration oil, when installing switch.

6. Evacuate, charge and check system operation.

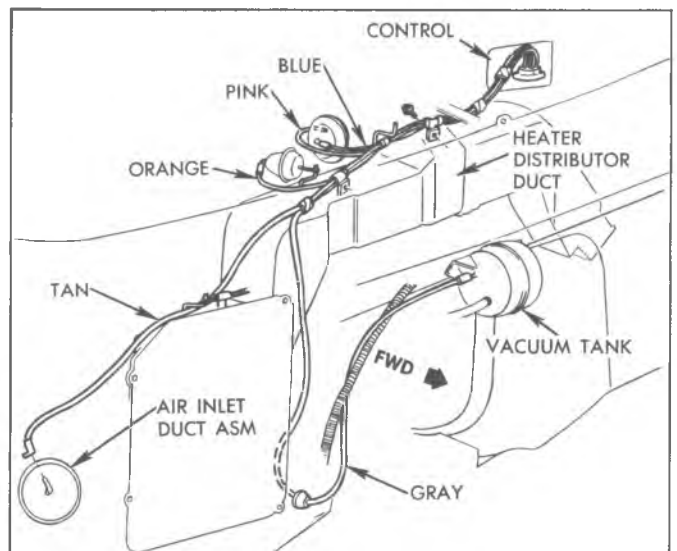

Fig. 86-Vacuum Harness (G Models)

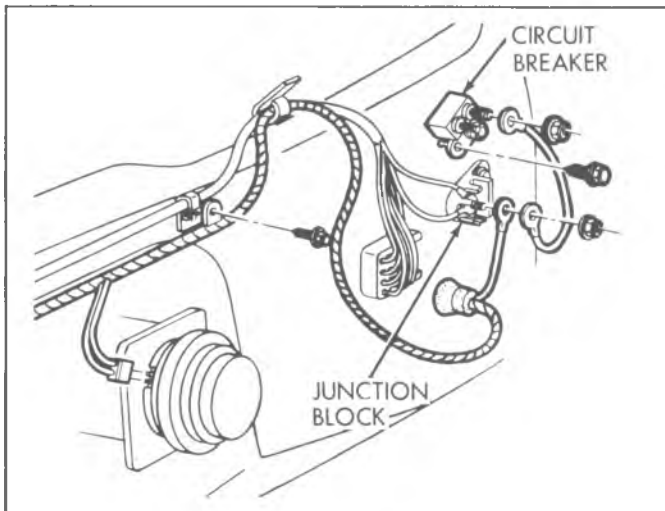

Fig. 87--Circuit Breaker

### VACUUM TANK

#### Replacement (Fig. 86)

1. Raise the hood.
2. Disconnect the vacuum harness at the tank.
3. Remove the tank attaching screws and remove the tank.
4. To install, reverse Steps 1-3 above.

### CIRCUIT BREAKER

The entire air conditioning system is protected by a 35 amp circuit breaker located on the left side of the dash, in the engine compartment.

## COMPONENT PART REPLACEMENT OVERHEAD SYSTEM--G MODELS

This system is used in conjunction with the C60 system. Since replacement of the C60 System Components has been covered previously, only those components peculiar to the Overhead system will be covered in this section.

### BLOWER-EVAPORATOR SHROUD

This shroud covers the blower-evaporator at the rear of the vehicle, and incorporates adjustable air outlets.

#### Replacement (Fig. 88)

1. Disconnect the battery ground cable.
2. Disconnect the drain tubes at the rear corners of the shroud.
3. Remove the screws securing the shroud to the unit and roof panel.

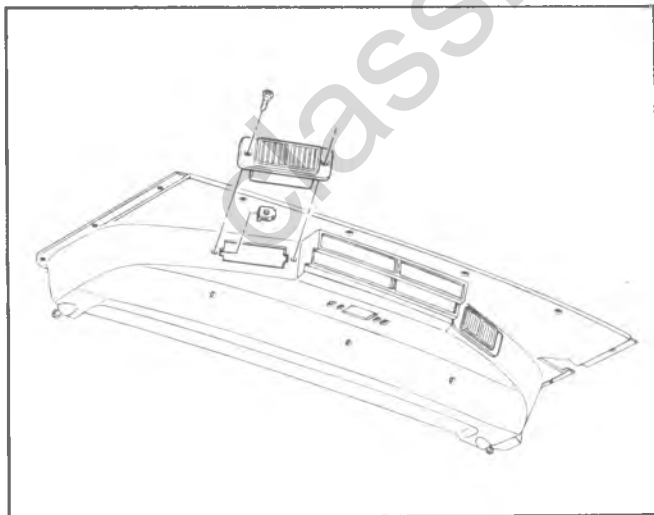

Fig. 88--Blower-Evaporator Shroud (G Overhead System)

### BLOWER MOTOR ASSEMBLIES

#### Removal (Fig. 89)

1. Disconnect the battery ground cable and compressor clutch connector.
2. Remove the blower-evaporator shroud as outlined previously.
3. Remove the blower motor ground straps at the center connector between the motors.
4. Disconnect the blower motor lead wires.

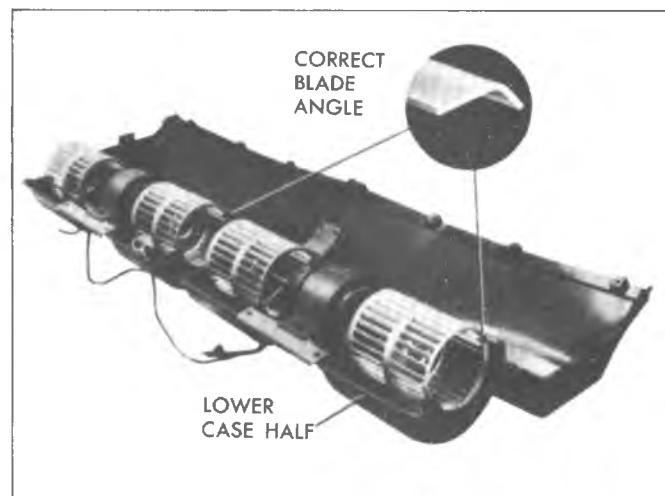

Fig. 89--Blower Motors (G Overhead System)

**WARNING:** Before removing the case screws, support the lower case to prevent damage to the case or motor assemblies.

- Remove the lower to upper blower-evaporator case screws and lower the lower case and motor assemblies.
- Remove the motor retaining strap and remove the motor and wheels. Remove the wheels from the motor shaft.

### Installation

- Place the blower wheels onto the motor shaft.  
**CAUTION:** Be sure that the blower wheels are installed as shown in Figure 89.
- Install the blower motor retaining strap and foam strip.
- Place the two blower motor and wheel assemblies into the lower case. Align the blower wheels so that they do not contact the case.
- Place the lower case and blower motor assemblies in position in the vehicle and install the lower to upper case screws.

**NOTE:** Rotate the blower wheels to make sure that they do not rub on the case.

- Install the center ground wires and connect the blower lead wires.
- Install the blower-evaporator shroud assembly as described previously.
- Connect the battery ground cable and compressor clutch connector.

### EXPANSION VALVES

This system incorporates two expansion valves. These valves do not use an external equalizer line (fig. 90).

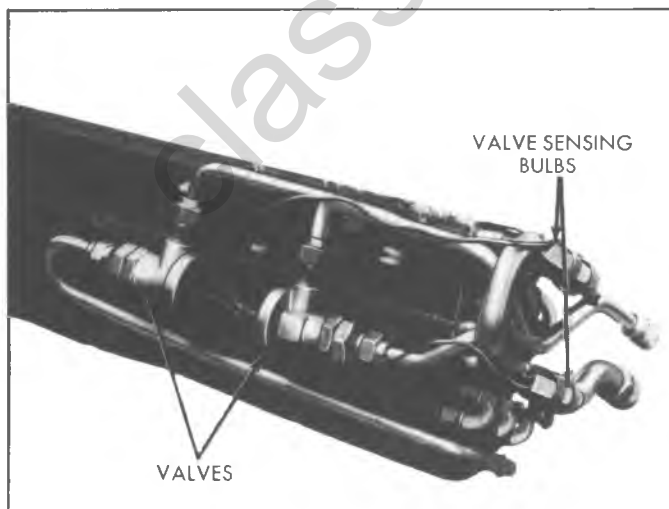

Fig. 90--Expansion Valves (G Overhead System)

### Removal (Inner Valve)

- Disconnect the battery ground cable and compressor clutch connector.
- Purge the system of refrigerant.
- Remove the blower-evaporator shroud as outlined previously.

**WARNING:** Before removing the lower case screws, support the case to prevent damage to the case or motor assemblies.

- Disconnect the center ground wire and the blower motor lead wires. Remove the lower to upper case screws and lower the lower case and blower motor assemblies.
- Disconnect the valve sensing bulb from the core outlet line.
- Disconnect the core inlet and outlet lines and remove the valve assembly. Cap or plug the open connections at once.

### Installation (Inner Valve)

- Remove caps or plugs from system connections and install the new valve assembly using new "O" rings coated with clean refrigeration oil.
- Install the sensing bulb, making sure that the bulb makes good contact with the core outlet line.
- Install the lower case and blower motor assemblies.
- Install the blower-evaporator shroud as outlined previously.
- Connect the battery ground cable and compressor clutch connector.
- Evacuate, charge and check the system.

### Removal (Outer Valve)

- Disconnect the battery ground cable and compressor clutch connector.
- Purge the system of refrigerant.
- Remove the blower-evaporator shroud as outlined previously.
- Disconnect the blower motor ground straps and leads.
- Disconnect the refrigerant lines at the rear of the blower-evaporator assembly. Cap or plug all open connections at once.
- Remove the blower-evaporator to roof panel attachments and lower the blower-evaporator assembly. Remove the assembly and place on a work bench upside down.
- Remove the lower to upper case screws and remove the lower case assembly. Remove the upper shroud from the upper case and then remove the upper case from the core.

## 1A-80 HEATER AND AIR CONDITIONING

8. Remove the expansion valve bulb from the evaporator outlet line. Remove the expansion valve inlet and outlet lines and cap or plug the open connections at once. Remove the valve.

### Installation (Outer Valve)

1. Remove the caps or plugs from the refrigerant connections and install the new valve using new "O" rings coated with clean refrigeration oil. Install the sensing bulb, making sure that the bulb makes good contact with the core outlet line.
2. Install the upper case to the core making sure the sealing strips are positioned correctly. Install the upper shroud on the upper case.
3. Install the lower case and blower assemblies.
4. Install the blower-evaporator to the roof panel.
5. Connect the refrigerant lines at the rear of the blower-evaporator unit using new "O" rings coated with clean refrigeration oil.
6. Connect the blower lead wires and ground straps.
7. Install the blower-evaporator shroud as described previously.
8. Connect the battery ground cable and the compressor clutch connector.
9. Evacuate, charge and check the system.

## EVAPORATOR CORE

### Removal (Fig. 91)

1. Disconnect the battery ground cable and compressor clutch connector.
2. Purge the system of refrigerant.
3. Remove the blower-evaporator shroud as outlined previously.

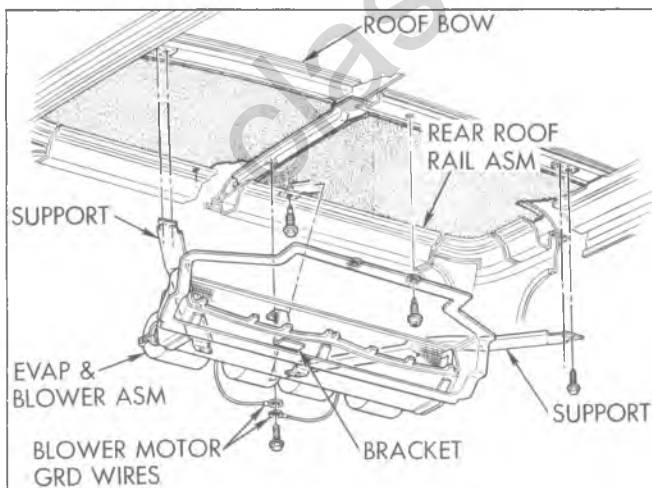

Fig. 91-Blower-Evaporator (G Overhead System)

4. Disconnect the blower motor leads and ground wire.
5. Disconnect the refrigerant lines at the rear of the blower-evaporator assembly. Cap or plug open connections at once.

**WARNING:** Before removing the blower-evaporator unit, support the case to prevent damage to components.

6. Remove the blower-evaporator to roof panel attachments and lower the blower-evaporator assembly. Remove the assembly and place it on a work bench upside down.
7. Remove the lower to upper case screws and remove the lower case assembly. Remove the upper shroud and upper case from the evaporator core.
8. Remove the expansion valve inlet and outlet lines and cap or plug the open connections at once. Remove the expansion valve capillary bulbs from the evaporator outlet line and remove the valves.
9. Remove the plastic pins holding the screen to the core and remove the screen.

### Installation

1. Install the wire screen to the front of the new core and insert the plastic pins.
2. Install the expansion valve inlet and outlet lines using new "O" rings coated with clean refrigeration oil. Install the sensing bulbs to the evaporator outlet line. Make sure the bulbs have good contact with the line.

**NOTE:** Add 3 oz. clean refrigeration oil when installing a new core.

3. Install the upper case and upper shroud to the core.
4. Install the lower core case and blower assemblies.
5. Install the blower-evaporator to the roof panel.
6. Connect the refrigerant lines to the blower-evaporator unit using new "O" rings coated with clean refrigeration oil.
7. Connect the blower lead wires and ground straps.
8. Install the blower-evaporator shroud as outlined previously.
9. Connect the battery ground cable and the compressor clutch connector.
10. Evacuate, charge and check the system.

## RESISTOR

See "Resistor" in the G Model C60 System Section of this manual (fig. 83).



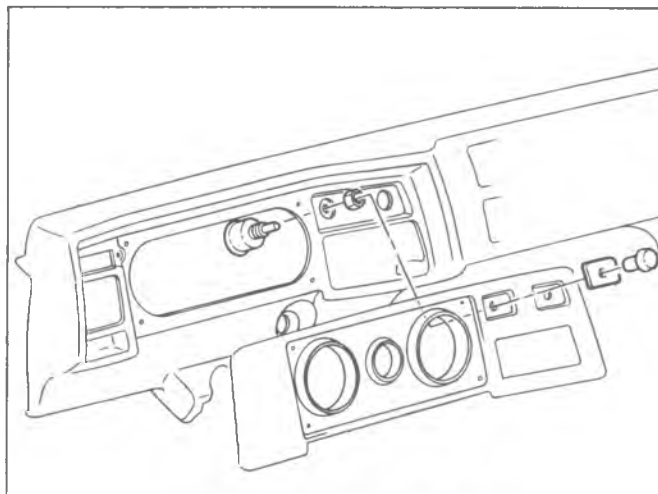

Fig. 92--Rear Blower Motor Switch

### BLOWER SWITCH

#### Replacement (Fig. 92)

1. Disconnect the battery ground cable.
2. Remove the headlamp and blower switch control knobs.
3. Remove the instrument panel bezel.
4. Disconnect the wiring harness at the switch.
5. Remove the switch locknut and remove the switch.
6. To install, reverse Steps 1-5 above.

### REAR BLOWER RELAY

The rear blower relay is attached to the instrument panel reinforcement, just left of the steering column (fig. 93).

#### Replacement

1. Disconnect battery ground cable.
2. Disconnect relay wiring harness at the relay.
3. Remove the relay attaching screw and remove the relay.
4. To install, reverse Steps 1-3 above. Check system operation.

### TIE RELAY

#### Replacement (Fig. 84)

1. Disconnect the battery ground cable.

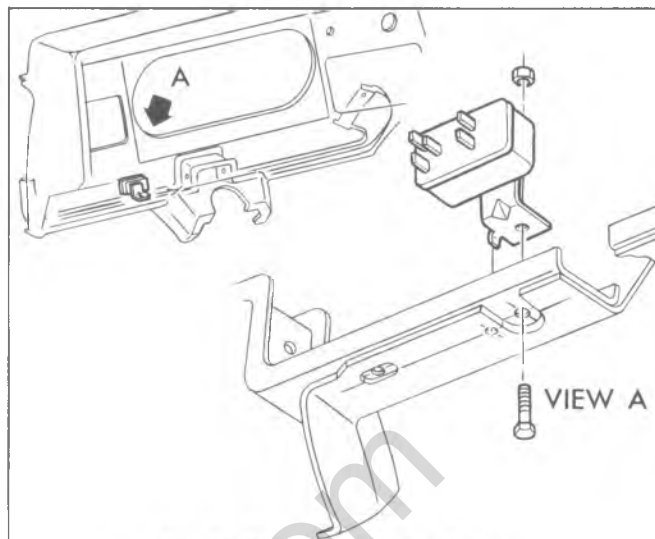

Fig. 93--Rear Blower Motor Relay

2. Remove screws securing the blower-evaporator shield; remove the shield. Remove the shield bracket to instrument panel reinforcement screws and remove the bracket.
3. Remove the heater intermediate duct to A/C distributor duct screw and remove the duct.
4. Unsnap the engine cover latches, remove the lower tab mounting bolts and remove the engine cover.
5. Loosen both steering column instrument panel reinforcement screws; remove one screw.
6. Remove the left foot cooler bracket to instrument panel reinforcement screws, disconnect the outlet from the duct and remove the outlet and bracket assembly.
7. Disconnect the speedometer cable.
8. Remove the instrument panel to lower reinforcement attaching screws. Rotate the instrument panel up to gain access to the relay.
9. Disconnect electrical harness at the relay.
10. Remove the relay mounting screw and remove the relay.
11. To install, reverse Steps 1-10 above.

## COMPONENT PART REPLACEMENT DASH MOUNTED SYSTEM--MOTOR HOME CHASSIS

This system is installed on the vehicle and checked at assembly. The blower-evaporator is then disconnected and shipped with the chassis unit to the body supplier. For this reason, it will only be possible to give basic replacement procedures on some components.

### CONDENSER

#### Replacement (Fig. 94)

1. Disconnect the battery ground cable.
2. Purge the system of refrigerant.
3. Disconnect the condenser inlet and outlet lines and cap or plug all open connections at once.

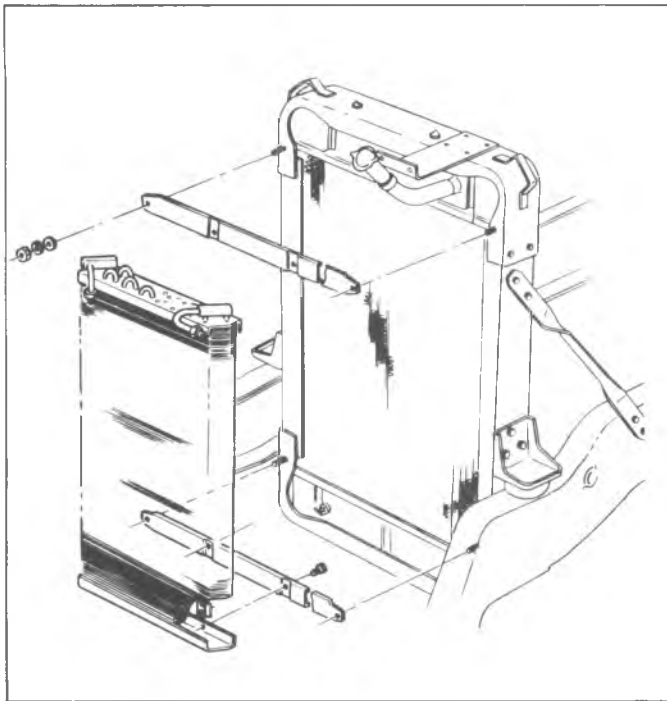

Fig. 94--Condenser (Motor Home Chassis Unit)

4. Remove the condenser to radiator support screws and remove the condenser.
5. To install a new condenser, reverse Steps 1-4 above. Add one fluid ounce of clean refrigeration oil to a new condenser.

NOTE: Use new "O" rings, coated with clean refrigeration oil, when connecting all refrigerant lines.

6. Evacuate, charge and check the system.

## RECEIVER-DEHYDRATOR

### Replacement (Fig. 95)

1. Disconnect the battery ground cable.
2. Purge the system of refrigerant.
3. Disconnect the inlet and outlet lines at the receiver-dehydrator and cap or plug the open lines at once.
4. Remove the receiver-dehydrator bracket attaching screws and remove the bracket and receiver-dehydrator.
5. To install a new receiver-dehydrator, reverse Steps 1-4 above. Add one fluid ounce of clean refrigeration oil to a new receiver-dehydrator.

NOTE: Use new "O" rings, coated with clean refrigeration oil, when connecting all refrigerant lines.

6. Evacuate, charge and check the system.

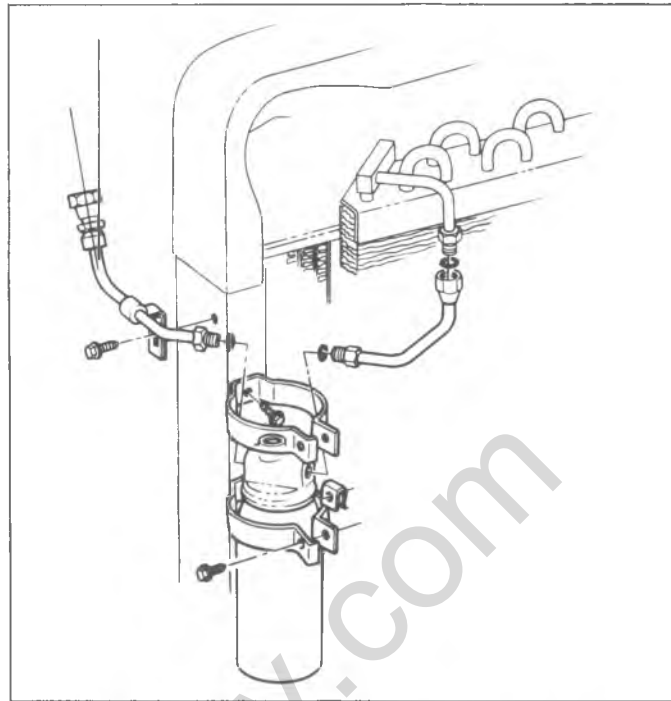

Fig. 95--Receiver-Dehydrator (Motor Home Chassis Unit)

## SIGHT GLASS REPLACEMENT

Refer to "Sight Glass Replacement" in the G Model C60 System Section of this manual.

## BLOWER-EVAPORATOR ASSEMBLY (Fig. 96)

### Removal

1. Disconnect battery ground cable.
2. Purge system of refrigerant.
3. Disconnect inlet and outlet refrigerant lines from the back of unit. Cap or plug all open connections at once.

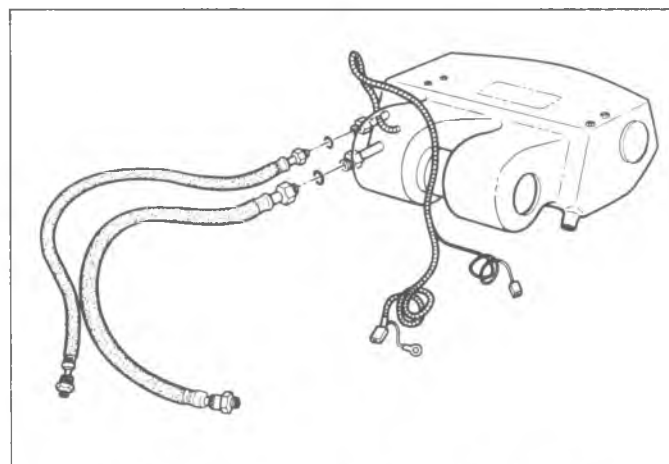

Fig. 96--Blower-Evaporator (Motor Home Chassis Units)

4. Disconnect drain tubes from evaporator case.
5. Disconnect electrical connector from compressor. Remove the terminal (See Figure 97) and allow connector to hang on ground wire.
6. Remove screws securing grommet retainer to dash panel. Remove wire from grommet through slit.
7. Disconnect electrical lead at connector.
8. Remove unit mounting bolts. Remove unit from vehicle, carefully pulling compressor electrical lead through dash panel.

Once the unit has been removed from the vehicle, continue with component replacement as follows:

### BLOWER ASSEMBLY

#### Removal (Fig. 98)

1. Remove the cover plate and separate the upper and

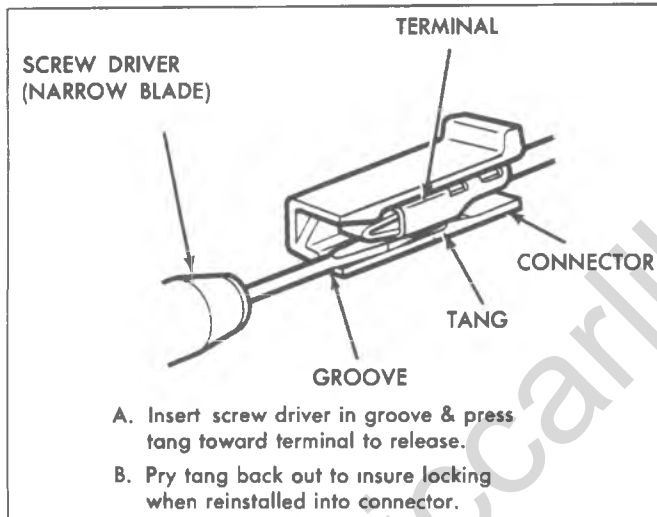

Fig. 97--Terminal Removal

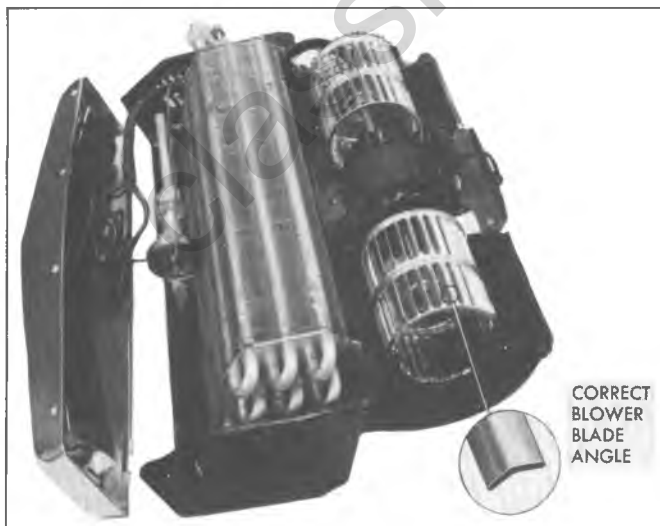

Fig. 98--Blower Assembly (Motor Home Chassis Unit)

lower case halves. Remove blower motor mounting strap screw and remove strap.

2. Remove blower assembly. Remove the wheels from the motor shaft.

#### Installation

1. Install the blower wheels on the motor so that the lower blades curve toward the dash panel side of the unit when the motor is placed in the case as illustrated in Figure 98.
2. Place the motor in the bracket with the electrical connector side of the motor to the right side of the bracket. Attach the mounting strap. Align blower wheels so that they do not contact case.
3. Assemble the case halves and attach the cover plate.
4. Reverse Steps 1-8 on the "Blower-Evaporator Assembly" removal procedure.
5. Evacuate, charge and check the system.

### EXPANSION VALVE, EVAPORATOR AND/OR EVAPORATOR CASE

#### Removal (Fig. 99)

1. Remove the cover plate and separate upper and lower case halves.
2. Remove inlet and outlet lines from the expansion valve. Remove sensing bulb from the evaporator outlet manifold. Remove expansion valve. Cap or plug open connections at once.
3. Remove evaporator core retaining screws and remove core.
4. Remove blower motor and harness assembly from case.

#### Installation

1. Reverse applicable steps in the removal procedure.

**CAUTION:** Use new "O" rings coated with

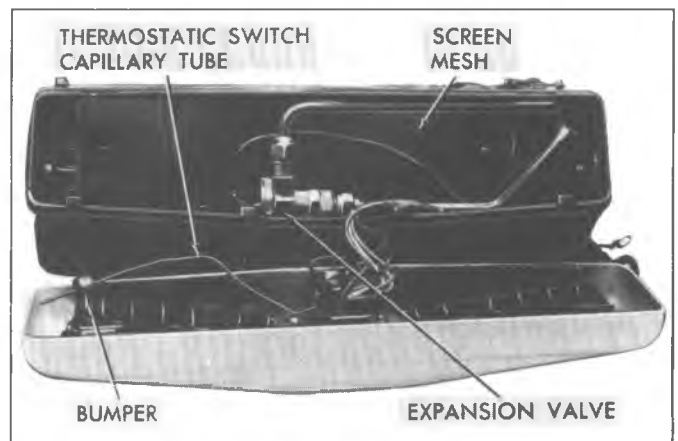

Fig. 99--Expansion Valve (Motor Home Chassis Unit)

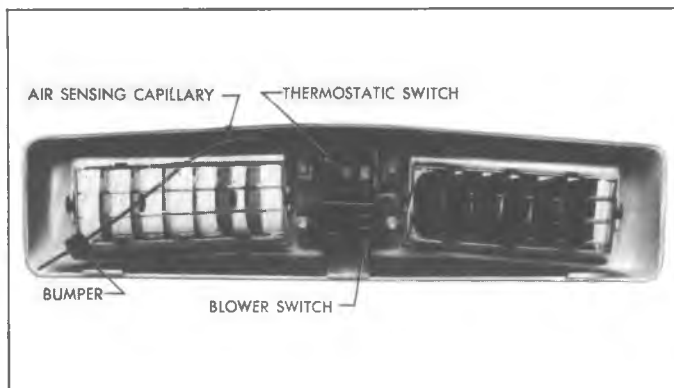

Fig. 100-Thermostatic and Blower Switches

*clean refrigeration oil when connecting lines. Add 3 oz. of new refrigeration oil to a new core.*

2. Reverse steps 1-8 of the "Blower Evaporator Assembly" removal procedure.
3. Evacuate, charge and check the system.

### THERMOSTATIC AND/OR BLOWER SWITCHES

#### Replacement

1. Remove the cover plate assembly from the

### REFRIGERANT SYSTEM

The following is a description of the type of symptom each refrigerant component will evidence if a defect occurs:

#### Compressor

A compressor defect will appear in one of four ways: Noise, seizure, leakage, or low discharge pressure (fig. 101).

**NOTE:** Resonant compressor noises are not cause for alarm; however, irregular noise or rattles may indicate broken parts or excessive clearances due to wear. To check seizure, de-energize the magnetic clutch and check to see if drive plate can be rotated. If rotation is impossible, compressor is seized (See "False Compressor Seizure"). To check for a leak, refer to leak testing in the service manual. Low discharge pressure may be due to a faulty internal seal of the compressor, or a restriction in the compressor.

Low discharge pressure may also be due to an insufficient refrigerant charge or a restriction elsewhere in the system. These possibilities should be checked prior to

evaporator case.

2. Remove two screws securing either switch to the cover plate and remove appropriate switch (fig. 100).
3. Install replacement switch, reinstall cover plate and reverse steps 1-8 of the "Blower-Evaporator Assembly" removal procedure.

**NOTE:** When installing thermostatic switch, be sure to position sensing capillary as when unit was removed.

### RESISTOR

The blower motor resistor is located on the top of the unit. The entire unit must be removed to replace the resistor.

### FUSE

This Unit does not incorporate an in-line fuse. The lead wire is connected to the Heater Wiring Harness and operates off the 20 amp Heater Fuse.

## DIAGNOSIS

servicing the compressor. If the compressor is inoperative, but is not seized, check to see if current is being supplied to the magnetic clutch coil terminals.

#### Condenser

A condenser may be defective in two ways: it may leak, or it may be restricted. A condenser restriction will result in excessive compressor discharge pressure. If a partial restriction is present, sometimes ice or frost will form immediately after the restriction as the refrigerant expands after passing through the restriction. If air flow through the condenser or radiator is blocked, high discharge pressures will result. During normal condenser operation, the outlet pipe will be slightly cooler than the inlet pipe.

#### Receiver-Dehydrator

A defective receiver-dehydrator may be due to a restriction inside the body of the unit. A restriction at the inlet to the receiver-dehydrator will cause high head pressures. Outlet tube restrictions will be indicated by low head pressures and little or no cooling. An excessively cold receiver-dehydrator outlet may be indicative of a restriction.

## Expansion Valve

A malfunction of the expansion valve will be caused by one of the following conditions: valve stuck open, valve stuck closed, broken power element, a restricted screen or an improperly located or installed power element bulb. The first three conditions require valve replacement. The last two may be corrected by replacing the valve inlet screen and by properly installing the power element bulb.

Attachment of the expansion valve bulb to the evaporator outlet line is very critical. The bulb must be attached tightly to the line and must make good contact with the line along the entire length of the bulb. A loose bulb will result in high low side pressures and poor cooling.

Indications of expansion valve trouble are provided by Performance Tests; consult Diagnostic Charts.

### VALVE STUCK OPEN

Noisy Compressor.

No Cooling - Freeze Up.

### VALVE STUCK CLOSED, BROKEN POWER ELEMENT OR PLUGGED SCREEN

Very Low Suction Pressure.

No Cooling.

### POORLY LOCATED POWER ELEMENT BULB

Normal Pressure.

Poor Cooling.

## Diagnosis for Defective Valve

The following procedure must be followed to determine if a malfunction is due to a defective expansion valve.

1. Check to determine if the system will meet the performance test as outlined previously. If the expansion valve is defective, the low pressure readings (evaporator pressure) will be above specifications.
2. The loss of system performance is not as evident when the compressor head pressure is below 200 psi. Therefore, it may be necessary to increase the system head pressure by partially blocking the condenser. Disconnect the blower lead wire and repeat the "performance check" to determine if the evaporator pressure can be obtained.
3. The system will also indicate a low refrigerant charge by bubbles occurring in the sight glass.

## Evaporator

When the evaporator is defective, the trouble will show up as an inadequate supply of cool air. A partially plugged core due to dirt, a cracked case, or a leaking seal will generally be the cause.

## Refrigerant Line Restrictions

Restrictions in the refrigerant lines will be indicated as follows:

1. Suction Line - A restricted suction line will cause low suction pressure at the compressor, low discharge pressure and little or no cooling.
2. Discharge Line - A restriction in the discharge line generally will cause the pressure relief valve to open.
3. Liquid Line - A liquid line restriction will be evidenced by low discharge and suction pressure, and insufficient cooling.

## Sight Glass Diagnosis (G and Motor Home Chassis Units)

At temperatures higher than 70 degrees F, the sight glass may indicate whether the refrigerant charge is sufficient. A shortage of liquid refrigerant is indicated after about five minutes of compressor operation by the appearance of slow-moving bubbles (vapor) or a broken column of refrigerant under the glass. Continuous bubbles may appear in a properly charged system on a cool day. This is a normal situation. If the sight glass is generally clear and performance is satisfactory, occasional bubbles do not indicate refrigerant shortage.

If the sight glass consistently shows foaming or a broken liquid column, it should be observed after partially blocking the air to the condenser. If under this condition the sight glass clears and the performance is otherwise satisfactory, the charge shall be considered adequate.

In all instances where the indications of refrigerant shortage continues, additional refrigerant should be added in 1/4 lb. increments until the sight glass is clear. An additional charge of 1/2 lb. should be added as a reserve after the glass clears. In no case should the system be overcharged.

## VACUUM SYSTEM DIAGNOSIS (C-K-G FOUR-SEASON SYSTEM)

Start the engine and allow it to idle - move the selector lever to each position and refer to the vacuum diagrams and operational charts for proper airflow, air door functioning and vacuum circuits. If airflow is not out of the proper outlets at each selector lever position, then proceed as follows:

1. **Check for good hose connections**--at the vacuum actuators, control head valve, reservoir, tees, etc.
2. **Check the vacuum source circuit as follows:**

Install vacuum tee and gauge (with restrictor) at the vacuum tank outlet (see Vacuum Diagram). Idle the engine and read the vacuum (a normal vacuum is equivalent to manifold vacuum) at all selector lever positions.

a. **Vacuum Less Than Normal At All Positions -**

Remove the tee and connect the vacuum gauge line directly to the tank - read the vacuum. If still low, then the problem lies in the feed circuit, the feed circuit to the tank or in the tank itself. If vacuum is now normal, then the problem lies downstream.

b. **Vacuum Less Than Normal at Some Positions -**

If vacuum was low at one or several of the selector lever positions, a leak is indicated in these circuits.

c. **Vacuum Normal at All Positions -**

If vacuum was normal and even at all positions, then the malfunction is probably caused by improperly connected or plugged lines or a defective vacuum valve or valves.

3. **Specific Vacuum Circuit Check**

Place the selector lever in the malfunctioning position and check for vacuum at the pertinent vacuum actuators. If vacuum exists at the actuator but the door does not move, then the actuator is defective or the door is mechanically bound. If low or no vacuum exists at the actuator, then the next step is to determine whether the cause is the vacuum harness or the vacuum valve. Check the vacuum harness first.

4. **Vacuum Harness Circuit Check**

- a. Disconnect the vacuum harness at the control head.
- b. The black line (#1) should show engine vacuum - if not, trace back through connector to vacuum tank.
- c. To check any individual circuit place the selector lever at the involved circuit position and check for vacuum presence.

Classiccarlibrary.com

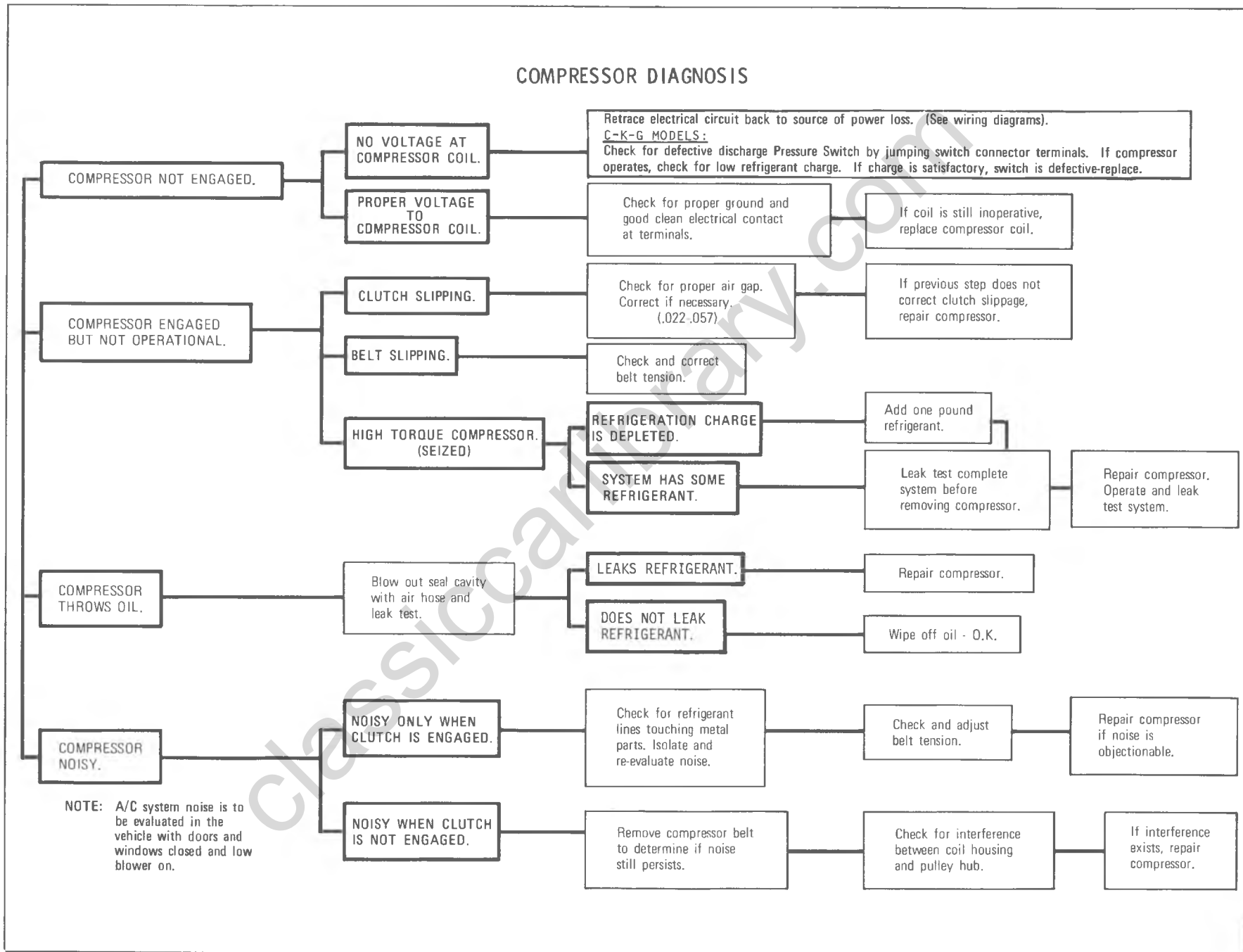

Fig. 101--Compressor Diagnosis

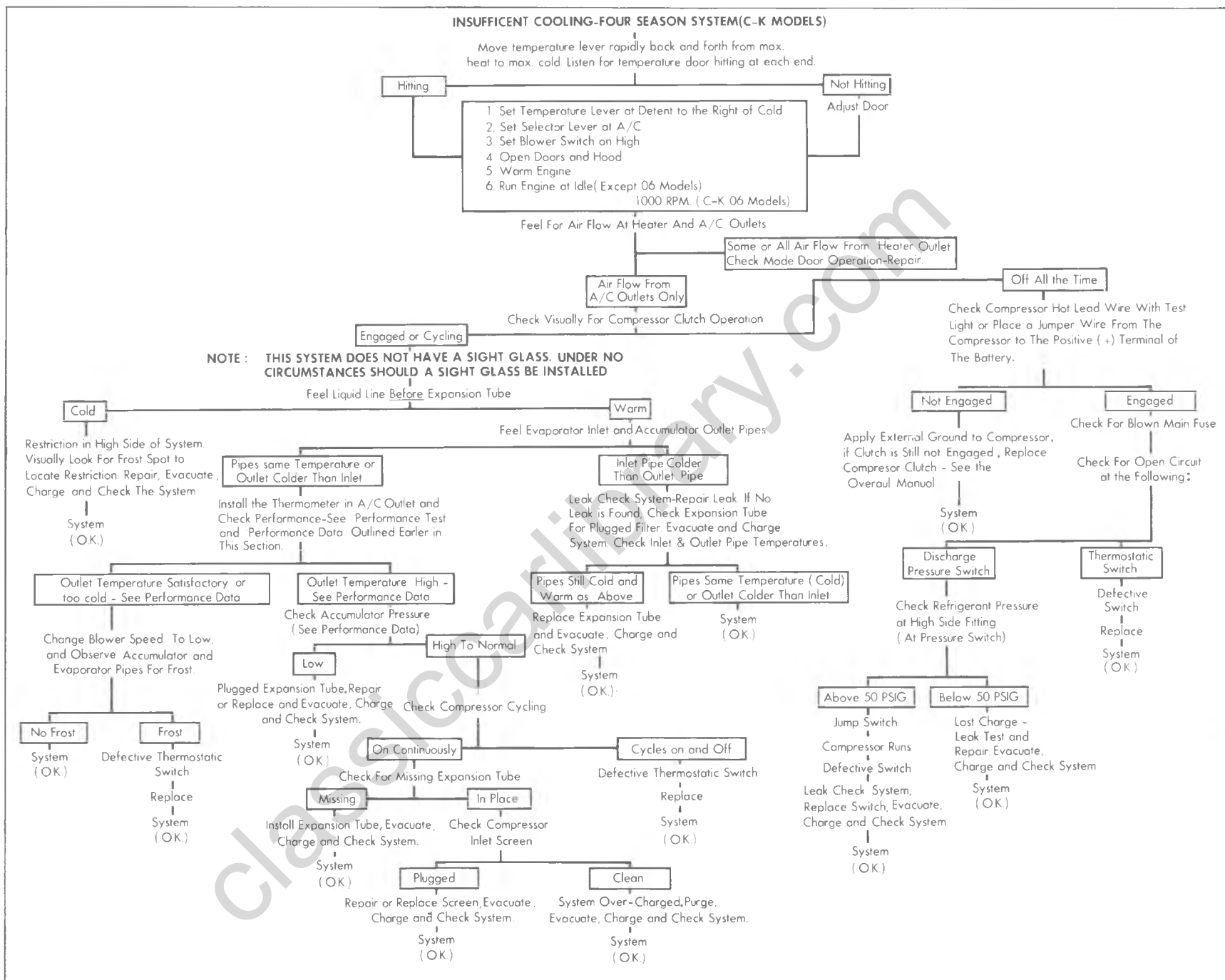

Fig. 102--Insufficient Cooling Diagnosis--C-K Four-Season System



## INSUFFICIENT COOLING DIAGNOSIS CHART (EXCEPT C-K FOUR-SEASON SYSTEM)

The following procedures should be applied before performance testing an A/C System.

1. Check for proper belt installation and tension with J-23600.
2. Check for proper clutch coil terminal connector installation.
3. Check for clutch air Gap (.022 - .057).
4. Check for broken, burst, or cut hoses. Also check for loose fittings on all components.

5. Check for condenser air blockage due to foreign material.
6. Check for proper air ducting hose connections.
7. Check heater temperature door adjustment, adjust if incorrect.
8. Check evaporator sealing for air leak, repair if leaking.
9. Install pressure gages and thermometer and make performance test.

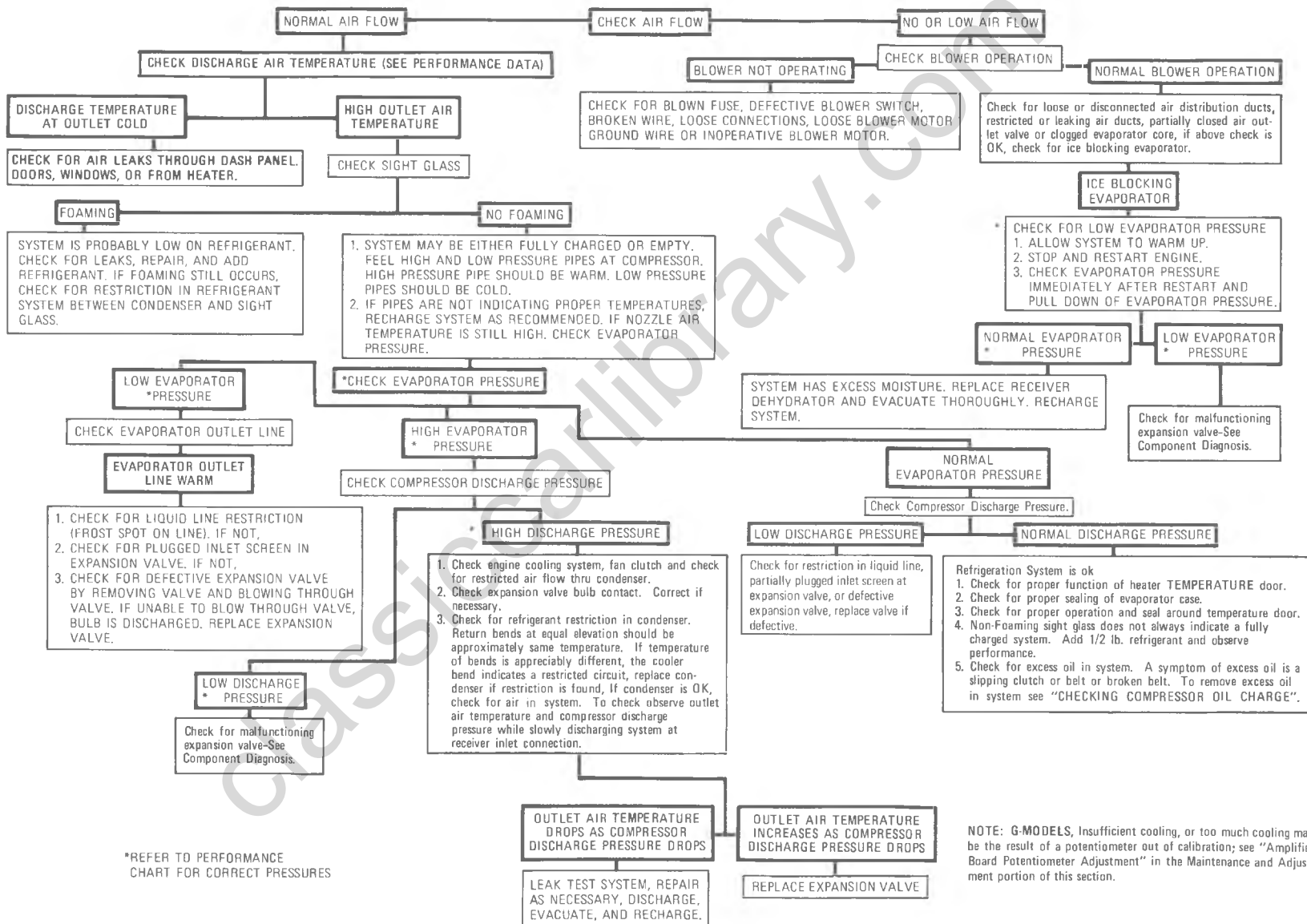

\*REFER TO PERFORMANCE CHART FOR CORRECT PRESSURES

NOTE: G-MODELS, Insufficient cooling, or too much cooling may be the result of a potentiometer out of calibration; see "Amplifier Board Potentiometer Adjustment" in the Maintenance and Adjustment portion of this section.

Fig. 103--Insufficient Cooling Diagnosis--Except C-K Four-Season System

ELECTRICAL SYSTEM DIAGNOSTIC CHART

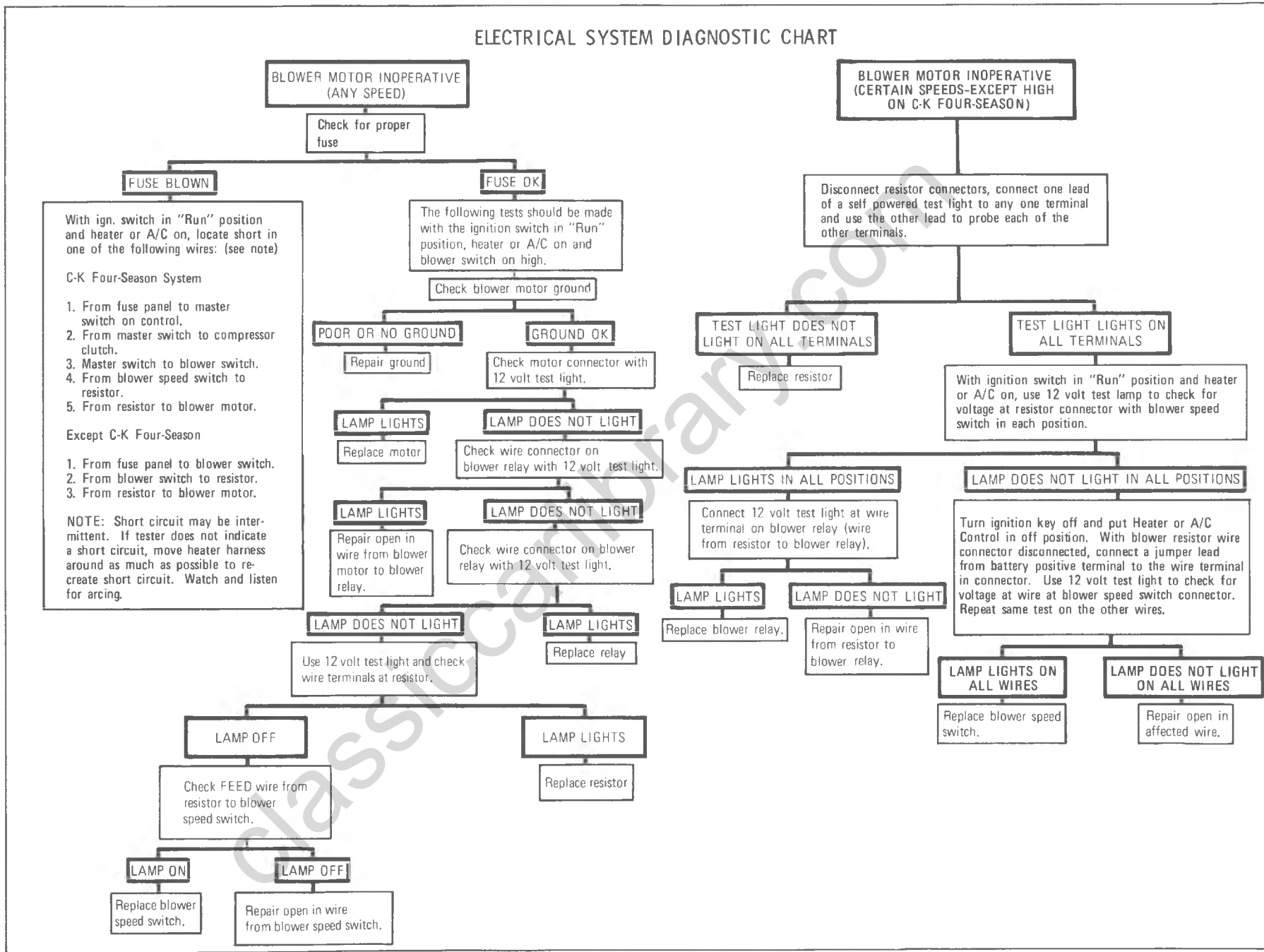
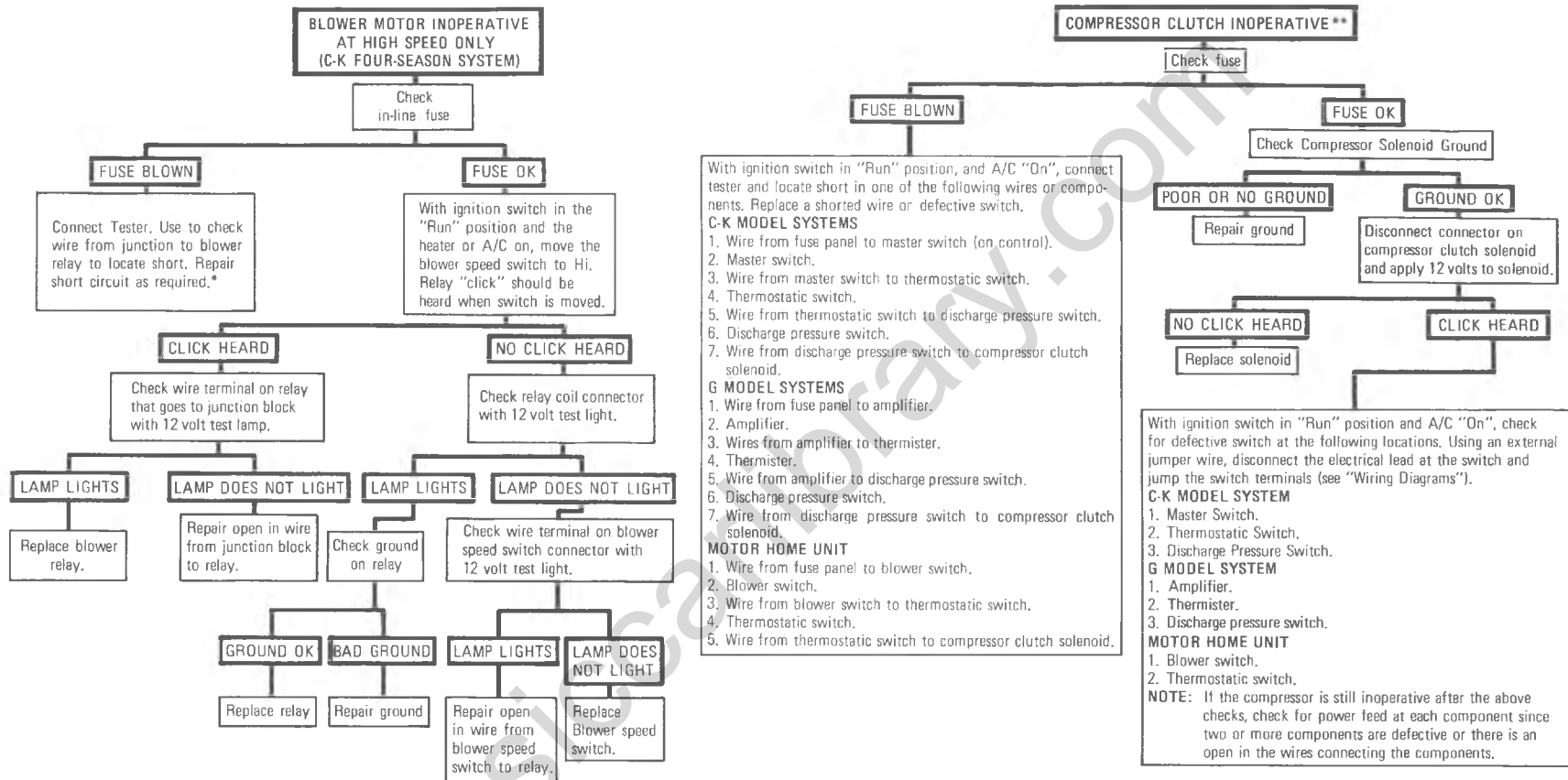

Fig. 104-Electrical System Diagnosis Chart

## ELECTRICAL SYSTEM DIAGNOSTIC CHART



\*Short circuit may be intermittent. If tester does not indicate a short circuit, move harness around as much as possible to re-create short circuit. Watch and listen for arcing.

\*\*Refer to Wiring Diagrams while performing the following checks.

Fig. 105--Electrical System Diagnosis Chart

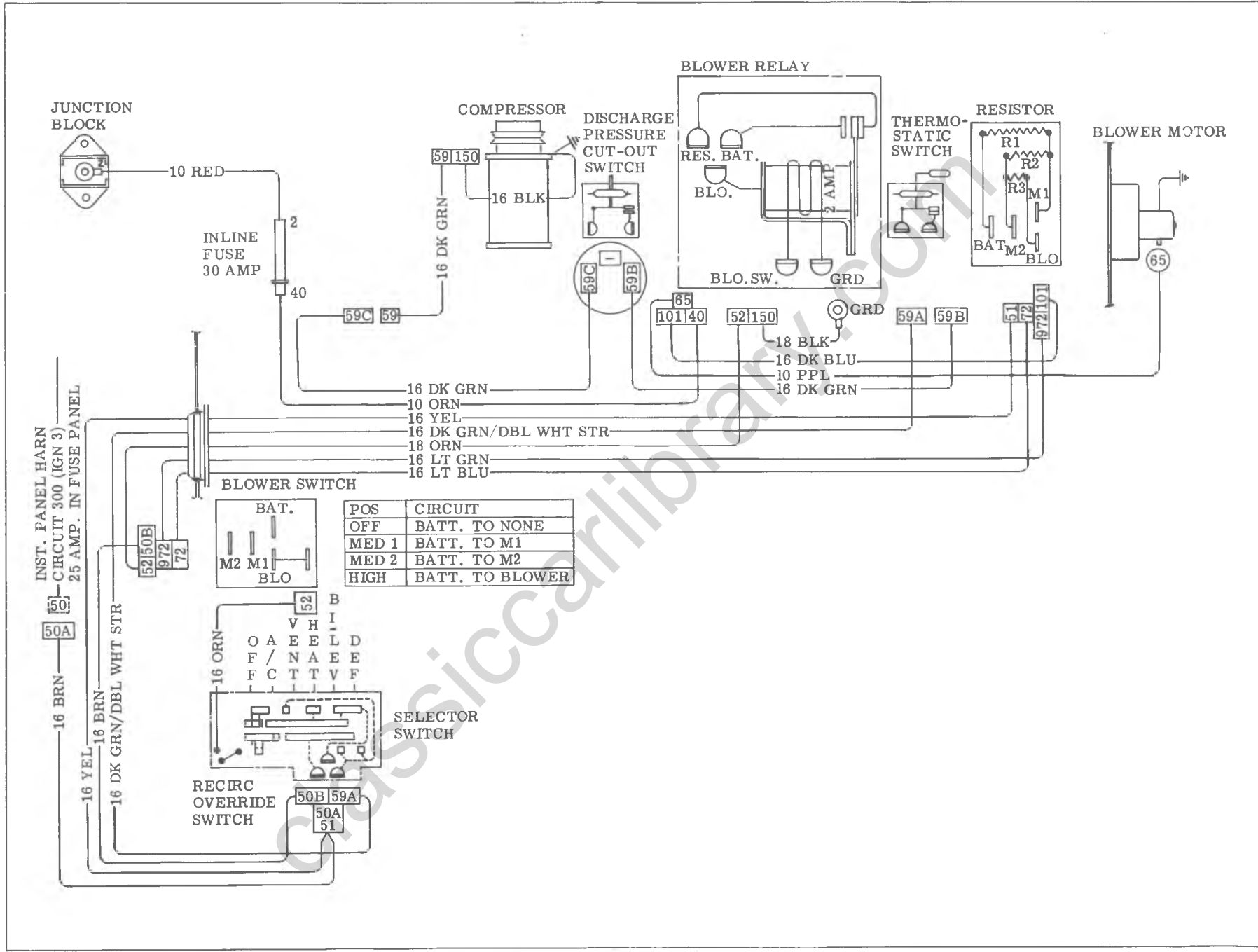

Fig. 106-Four-Season System Wiring Diagram (C-K Models)

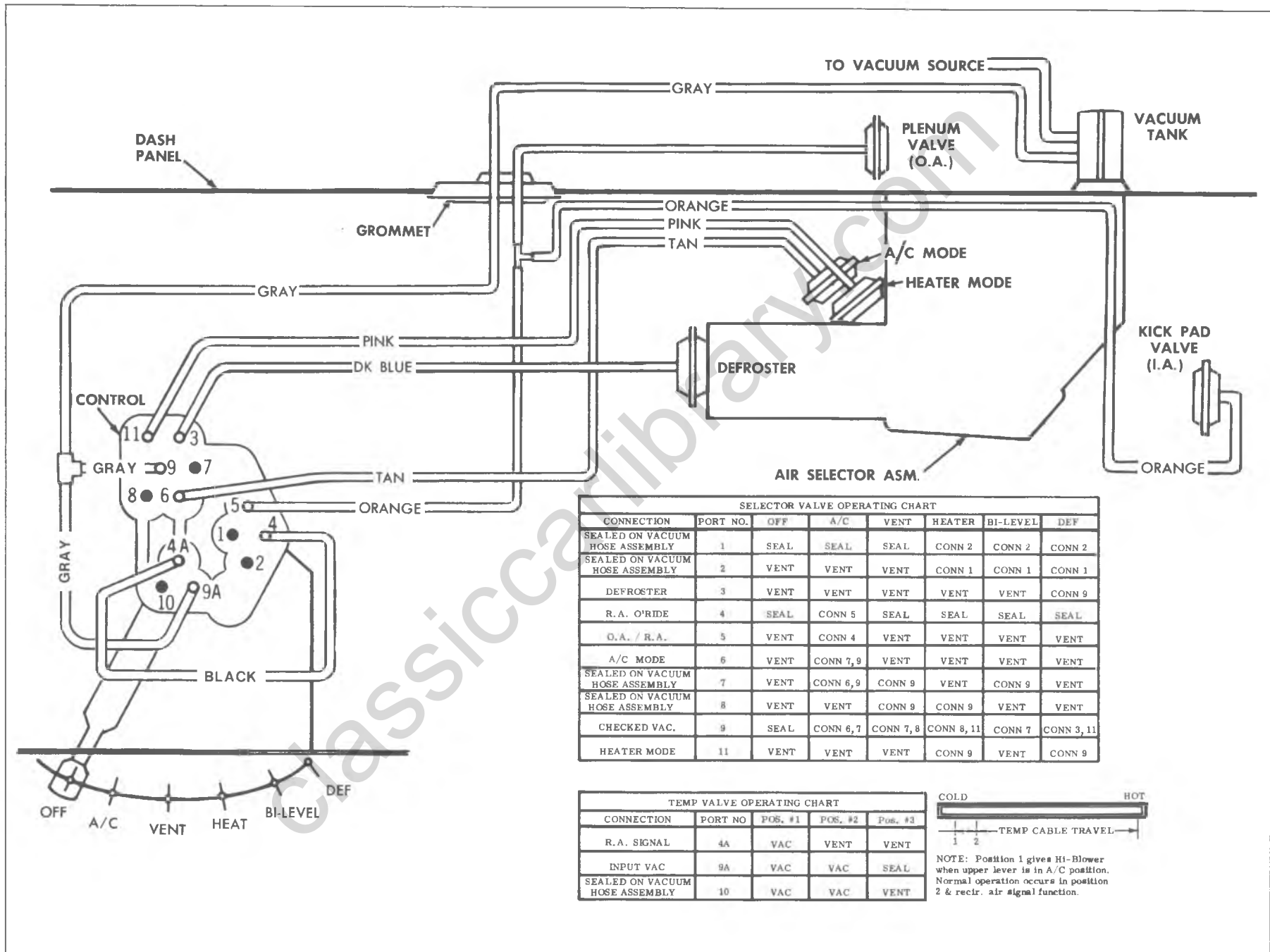

Fig. 107--Four-Season System Vacuum Diagram (C-K Models)

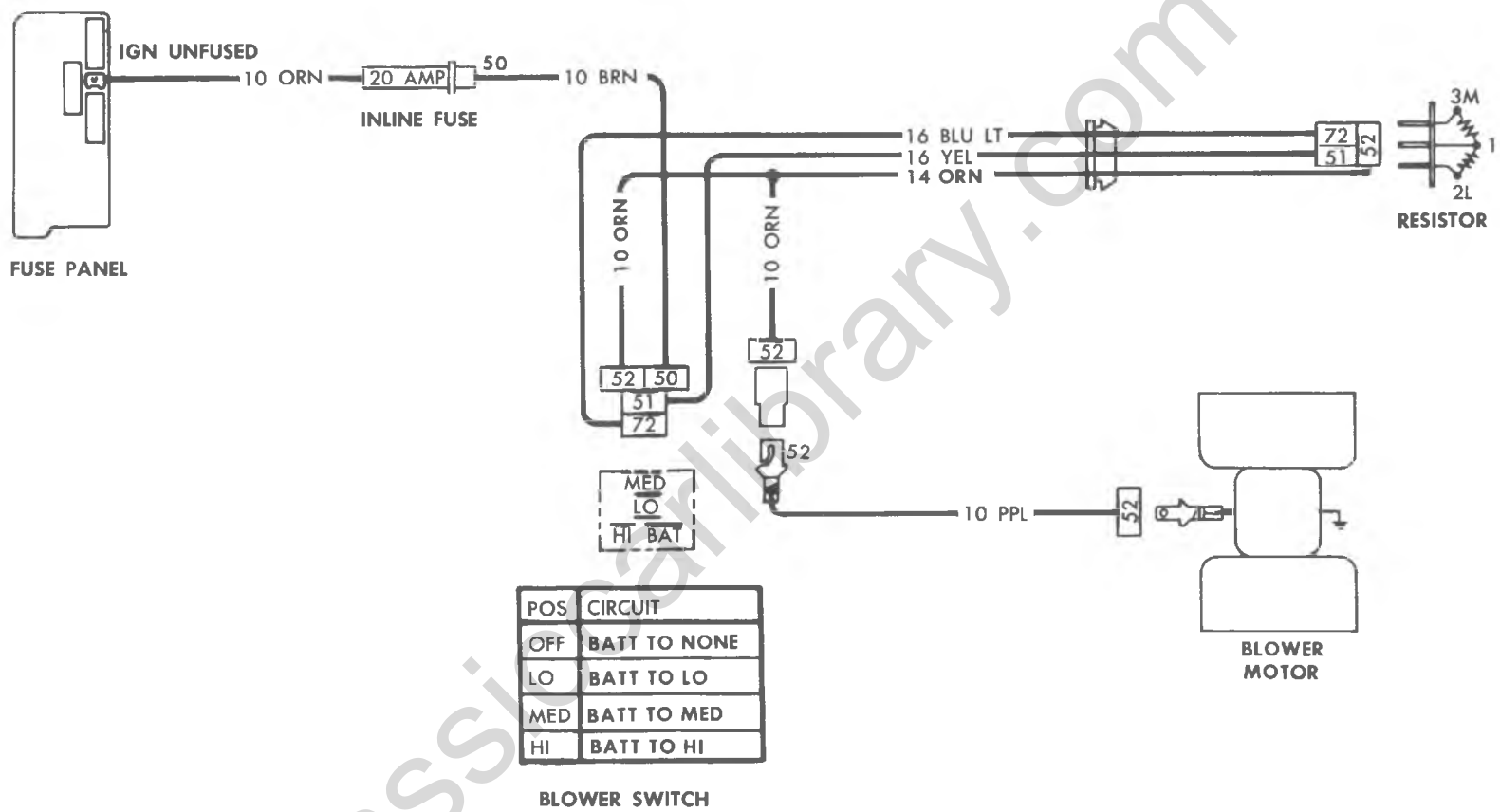

Fig. 108--Overhead System Wiring Diagram (C-K Models)



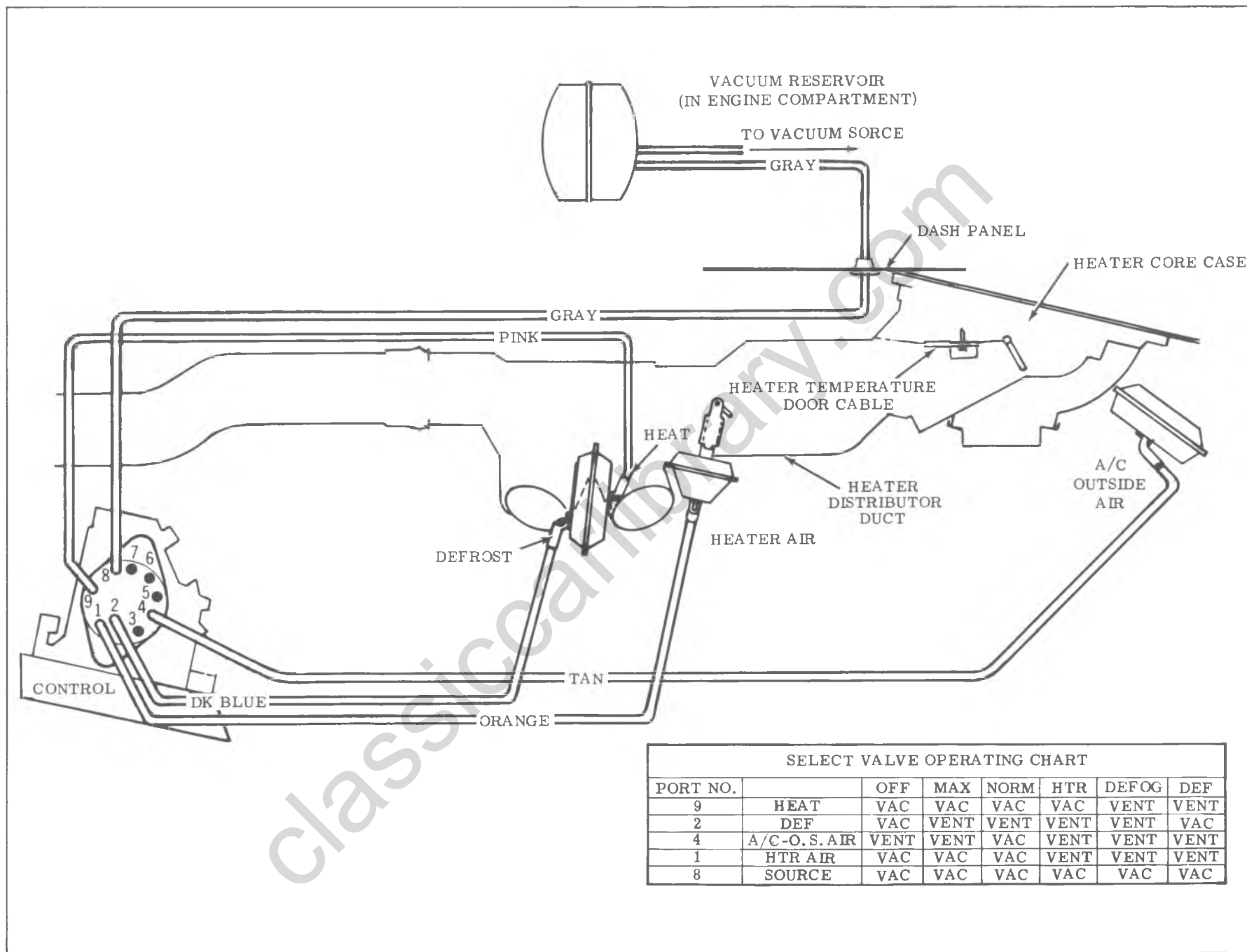

Fig. 110-C60 System Vacuum Diagram (G Models)





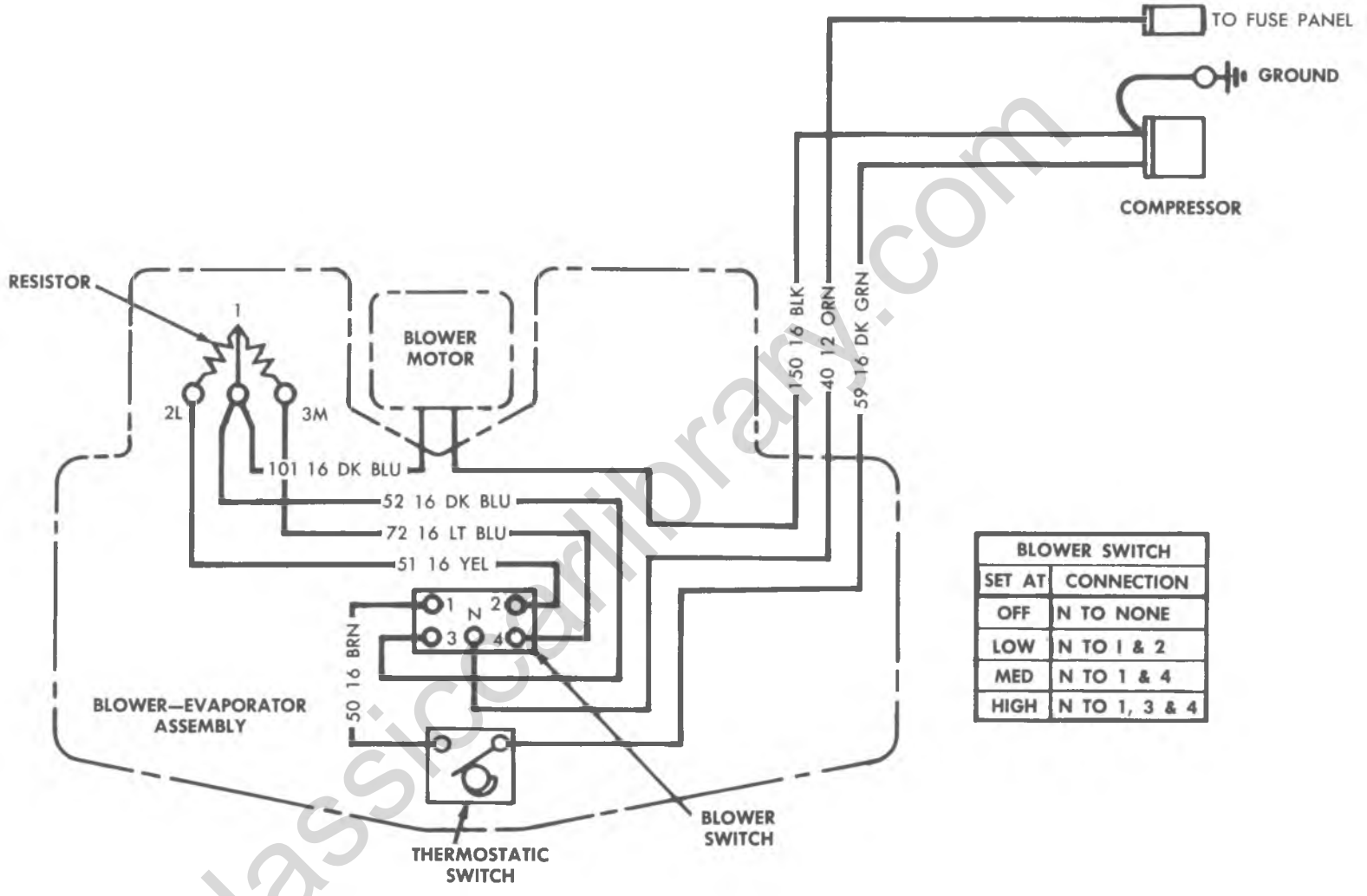
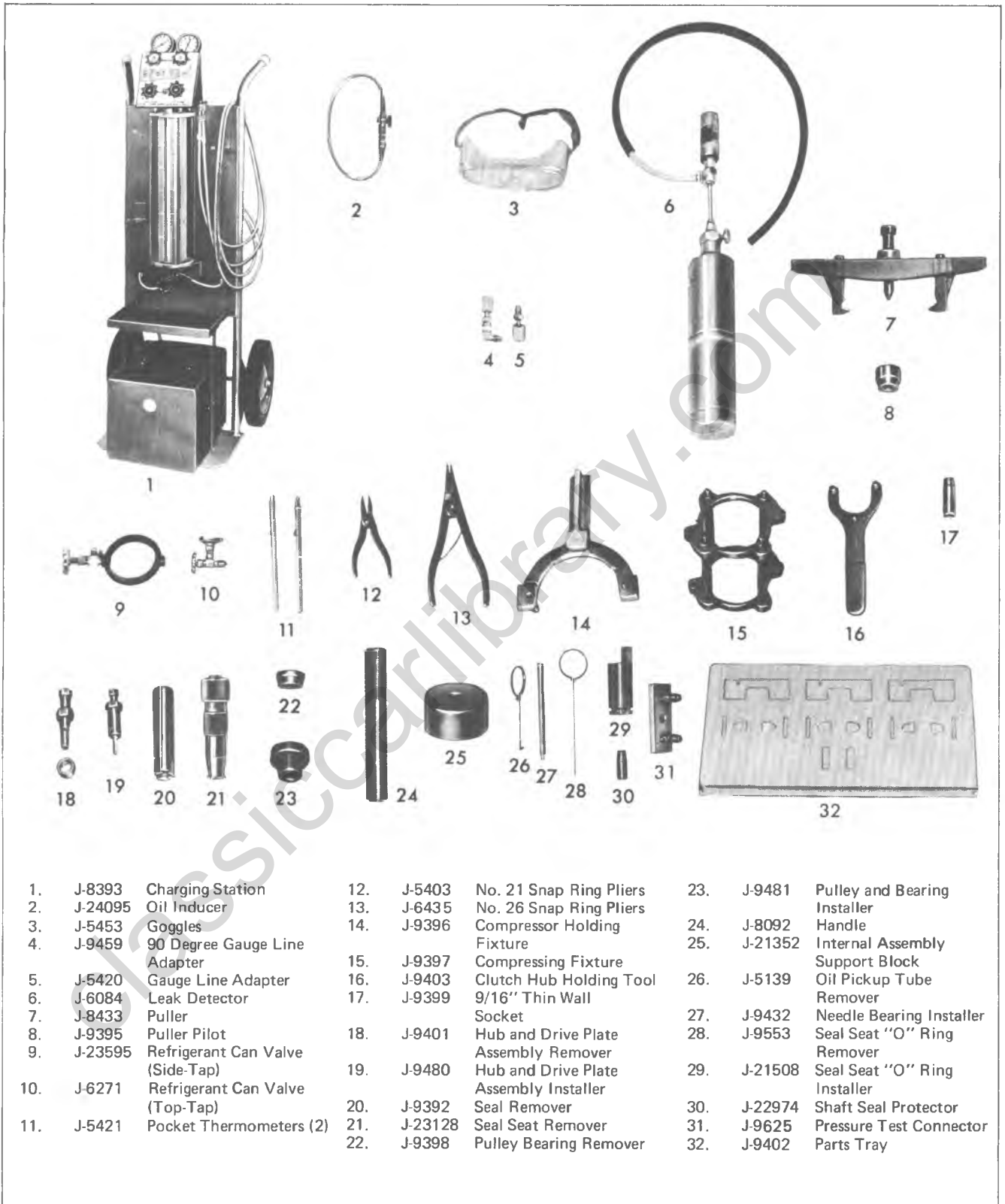

Fig. 112--Motor Home Chassis Wiring Diagram

## SPECIAL TOOLS



- |     |         |                                  |     |         |  |     |         |                                 |
|-----|---------|----------------------------------|-----|---------|--|-----|---------|---------------------------------|
| 1.  | J-8393  | Charging Station                 | 12. | J-5403  | No. 21 Snap Ring Pliers                | 23. | J-9481  | Pulley and Bearing Installer    |
| 2.  | J-24095 | Oil Inducer                      | 13. | J-6435  | No. 26 Snap Ring Pliers                | 24. | J-8092  | Handle                          |
| 3.  | J-5453  | Goggles                          | 14. | J-9396  | Compressor Holding Fixture             | 25. | J-21352 | Internal Assembly Support Block |
| 4.  | J-9459  | 90 Degree Gauge Line Adapter     | 15. | J-9397  | Compressing Fixture                    | 26. | J-5139  | Oil Pickup Tube Remover         |
| 5.  | J-5420  | Gauge Line Adapter               | 16. | J-9403  | Clutch Hub Holding Tool                | 27. | J-9432  | Needle Bearing Installer        |
| 6.  | J-6084  | Leak Detector                    | 17. | J-9399  | 9/16" Thin Wall Socket                 | 28. | J-9553  | Seal Seat "O" Ring Remover      |
| 7.  | J-8433  | Puller                           | 18. | J-9401  | Hub and Drive Plate Assembly Remover   | 29. | J-21508 | Seal Seat "O" Ring Installer    |
| 8.  | J-9395  | Puller Pilot                     | 19. | J-9480  | Hub and Drive Plate Assembly Installer | 30. | J-22974 | Shaft Seal Protector            |
| 9.  | J-23595 | Refrigerant Can Valve (Side-Tap) | 20. | J-9392  | Seal Remover                           | 31. | J-9625  | Pressure Test Connector         |
| 10. | J-6271  | Refrigerant Can Valve (Top-Tap)  | 21. | J-23128 | Seal Seat Remover                      | 32. | J-9402  | Parts Tray                      |
| 11. | J-5421  | Pocket Thermometers (2)          | 22. | J-9398  | Pulley Bearing Remover                 |     |         |                                 |

Fig. 113-Air Conditioning Special Tools

classicalibrary.com

## SECTION 1B

### BODY

The following caution applies to one or more steps in the assembly procedure of components in this portion of the manual as indicated at appropriate locations by the terminology "See Caution on page 1 of this Section".

**CAUTION: THIS FASTENER IS AN IMPORTANT ATTACHING PART IN THAT IT COULD AFFECT THE PERFORMANCE OF VITAL COMPONENTS AND SYSTEMS, AND/OR COULD RESULT IN MAJOR REPAIR EXPENSE. IT MUST BE REPLACED WITH ONE OF THE SAME PART NUMBER OR WITH AN EQUIVALENT PART IF REPLACEMENT BECOMES NECESSARY. DO NOT USE A REPLACEMENT PART OF LESSER QUALITY OR SUBSTITUTE DESIGN. TORQUE VALUES MUST BE USED AS SPECIFIED DURING REASSEMBLY TO ASSURE PROPER RETENTION OF THIS PART.**

#### CONTENTS OF THIS SECTION

General Description.....	1B-1
C-K Models.....	1B-4
G Models.....	1B-30
Special Tools.....	1B-48

#### GENERAL DESCRIPTION

On the following pages, service procedures will be given for components on all 10-20-30 series trucks in C, K and G models. Reference will be made, both in text and illustrations, to vehicle model lines and to individual model numbers within these model lines.

As an aid to identification of specific models, the following general descriptions are given.

##### Chassis/Cabs

All chassis/cabs use "03" as the model identification. See figure 1. Two-wheel drive units come in C-10, C-20 and C-30 series. Four-wheel drive units may be either K-10 or K-20. Optional pickup boxes are available.

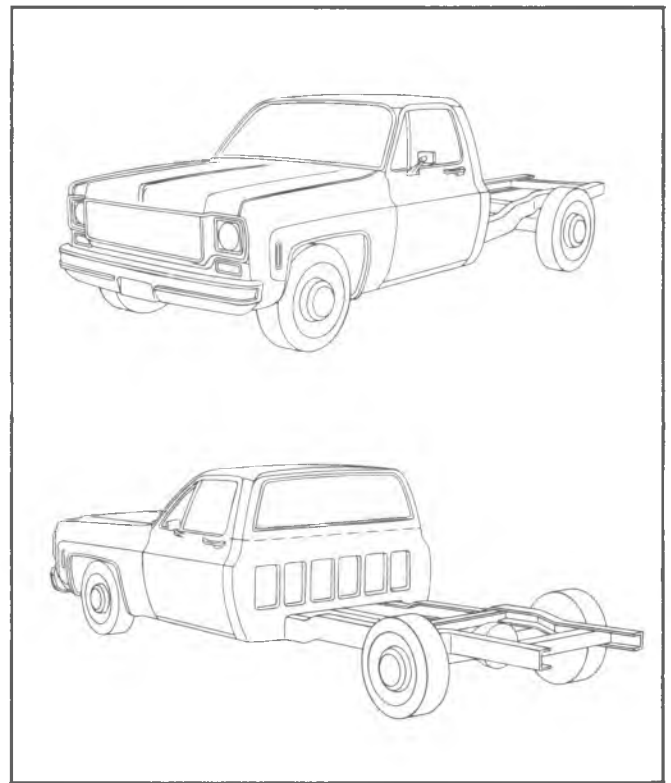

Fig. 1—Typical Chassis/Cab

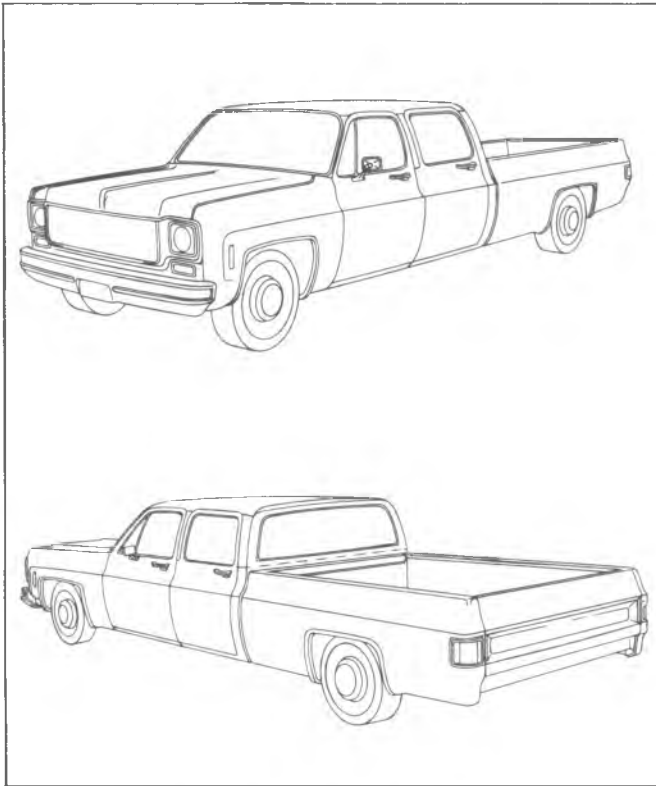

Fig. 2—Typical Crew Cab/Chassis



Fig. 3—Typical Coach

### Crew Cab/Chassis

Model number "63" designates the crew cab/chassis models. See figure 2. Optional pickup boxes are available.

### Coach

The four-door coach model number is "06". See figure 3. Base models have rear cargo doors. An optional endgate with moveable window is available.

### Utility

Utility models are designated with the number "14". See figure 4. An optional removable roof is also available.

### Vans

G-Series Vans are available in three model number designations. See figures 5 and 6. Vans without body windows use number "05"; vans with body windows are "06" models; "03" vans have an open cargo area, as shown in figure 6.



Fig. 4—Typical Utility Vehicle

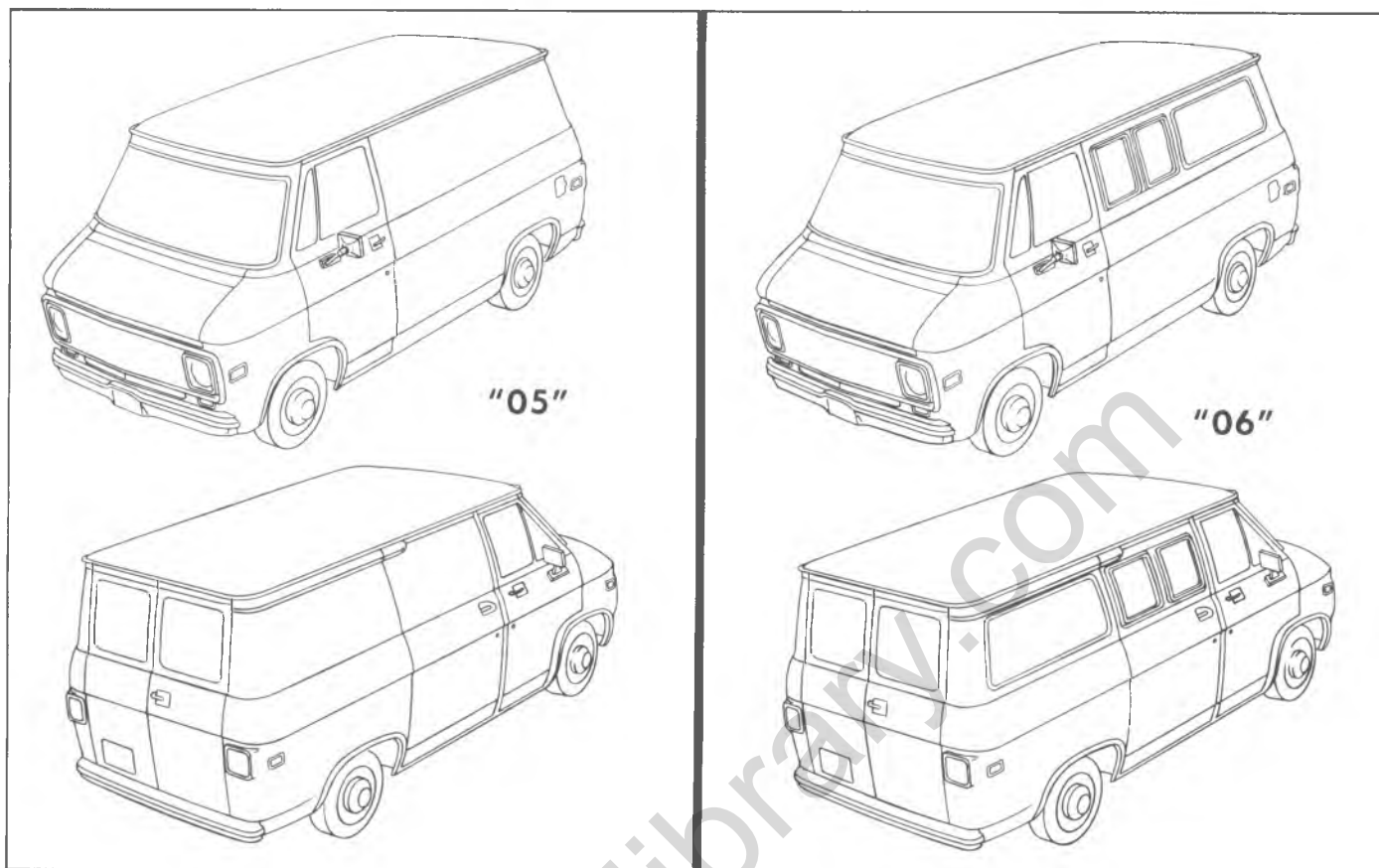

Fig. 5—Typical "05" and "06" Vans

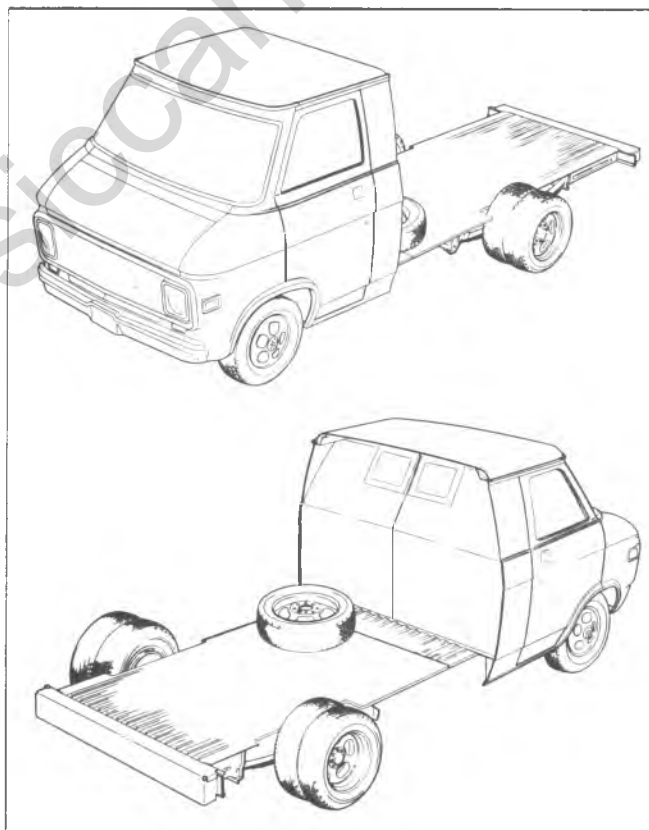

Fig. 6—Typical "03" Van

## C-K MODELS

## INDEX

**Front End**

Windshield Wipers.....	1B-4
Glove Box.....	1B-5
Rear View Mirrors.....	1B-5

**Body Glass**

Windshield Glass.....	1B-6
Stationary Body Glass.....	1B-9

**Side Doors**

Adjustments.....	1B-9
Front Side Door.....	1B-10
Replacement.....	1B-10
Hinges.....	1B-10
Ventilator.....	1B-10
Window and Regulator.....	1B-12
Locks, Handles, Rods.....	1B-12
Weatherstrip.....	1B-14
Rear Side Doors.....	1B-14

Replacement.....	1B-14
Hinges.....	1B-14
Stationary Glass.....	1B-14
Window and Regulator.....	1B-15
Locks, Handles, Rods.....	1B-15
Weatherstrip.....	1B-16

**Rear Doors**

Adjustments.....	1B-16
Locks, Handles, Rods.....	1B-17
Hinges.....	1B-18

**Gates**

Endgates.....	1B-19
Tailgates.....	1B-23

**Removable Top (Utility).....**

1B-24

**Seats.....**

1B-25

**Body Mounting.....**

1B-28

## FRONT END

**WINDSHIELD WIPERS**

Windshield wiper units on all models are of the two-speed electric type. A single wiper motor unit, mounted to the left side of the dash panel inside the engine compartment, powers both wiper blades. The wiper blade operating link rods and pivot mountings on these models are located in the outside air inlet plenum chamber.

**Arm Adjustment**

To adjust sweep of blades, turn on wipers and note sweep of arms. If necessary, remove one or both arms as follows: Pull outer end of arm away from glass which will trip lock spring at base of arm and release spring from undercut of pivot shaft. While holding arm in this position, pull outward on cap section at base of arm to remove arm. Arm can be reinstalled in any one of several positions due to serrations on pivot shaft and in arm cap. See figure 7.

**Wiper Arm Pivot Shafts and Linkage****Removal**

1. Remove windshield wiper arms from pivot shafts. Procedure for removing arms is explained previously under "Arm Adjustment".
2. Remove two nut and lock washer assemblies from the connector link to motor drive arm via the plenum access hole.
3. Remove two screws from each transmission pivot shaft assembly to windshield frame. Remove wiper linkage and transmission from plenum.

**Installation**

1. Place wiper linkage and transmission into position. Secure assembly with two screws at each transmission.
2. Attach end of cross rod to drive arm of motor assembly. Secure rod.
3. Before installing wiper arms, operate wiper motor momentarily which should rotate pivot shafts to park position. Install arms and shafts.

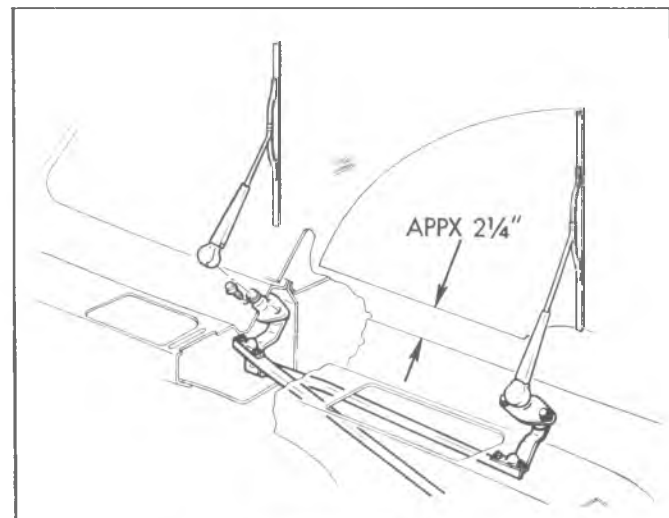

Fig. 7—Windshield Wipers



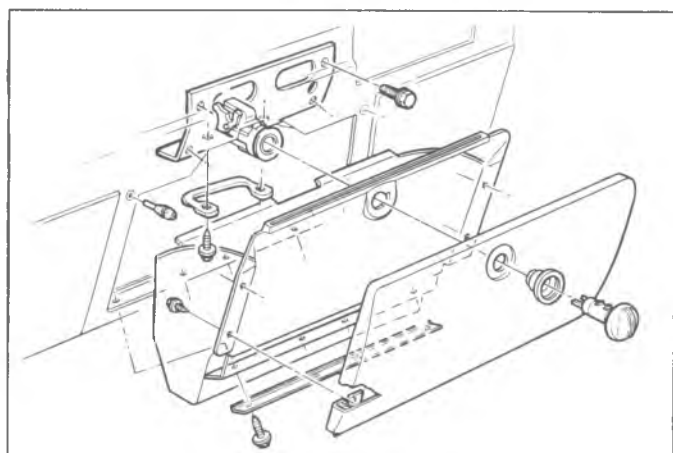

Fig. 8—Glove Box

## INSTRUMENT PANEL COMPARTMENT AND LOCK

### Replacement

Removal of the entire assembly including door may be accomplished by removing four screws which attach hinge just below box. See figure 8. The outer door panel may be removed, leaving the compartment intact, by removal of four screws. Access to the door stop bumper is gained by reaching into compartment opening with door partially open.

### Adjustment

Engagement of lock in striker may be adjusted by loosening striker retaining screws and moving the striker to desired position.

## OUTSIDE REAR VIEW MIRRORS

Rear view mirror installations are shown in figures 9, 10 and 11. Occasional tightening of mounting and assembly bolts and screws will sharply decrease occurrence of failure due to door slamming or road shock.

NOTE: Camper mirror installation is similar to the below eyeline mirror installation.

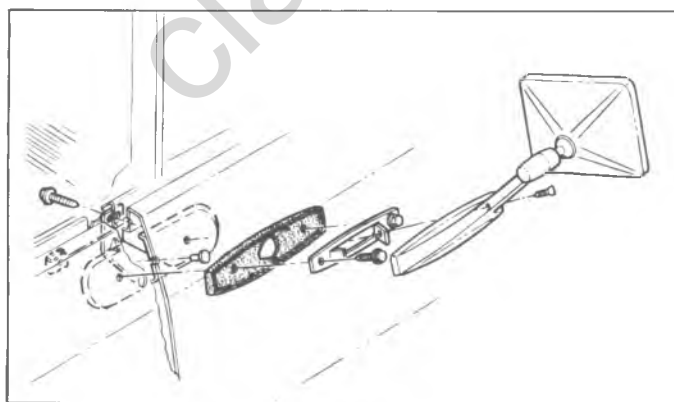

Fig. 9—Rear View Mirror—Base

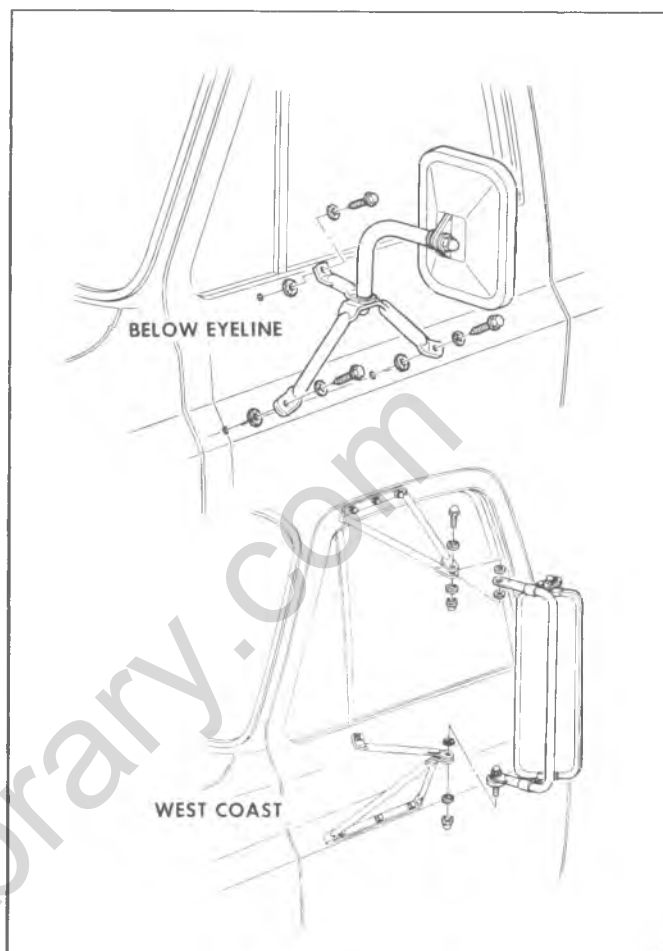

Fig. 10—Rear View Mirrors

## INSIDE REAR VIEW MIRROR—FIGURE 11

### Replacement

1. Remove screw retaining mirror to its glass-mounted bracket and remove mirror.
2. Install mirror into its mounting bracket. Torque screw to specifications.

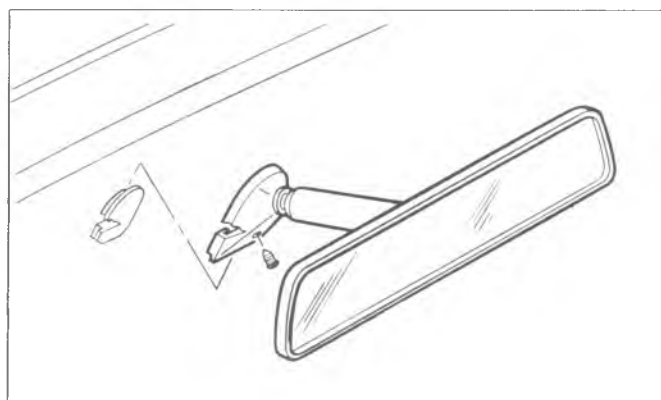

Fig. 11—Inside Rear View Mirror

**COWL VENT VALVE—FIGURE 12****Replacement**

The entire vent valve assembly may be removed from the vehicle by removing attaching screws shown in figure 12.

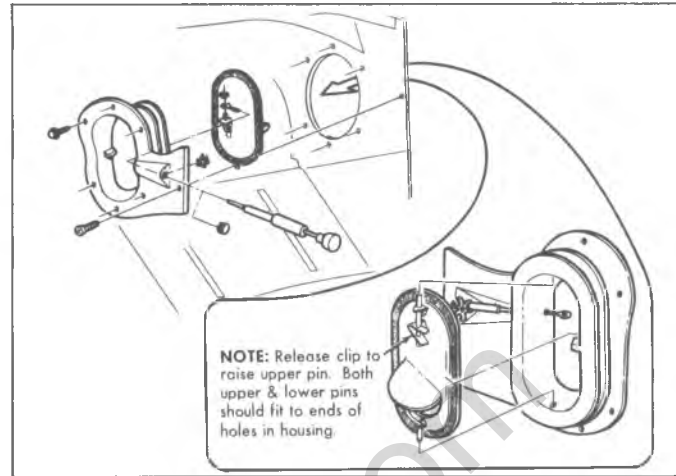

Fig. 12—Cowl Vent Valve

**BODY GLASS**

**WARNING:** Always wear gloves when handling glass.

**WINDSHIELD GLASS**

The windshield is a one-piece type and is retained in the windshield opening by a moulded rubber weatherstrip. See figure 13.

When replacing a cracked windshield glass, it is very

important that the cause of the glass breakage be determined and the condition corrected before a new glass is installed. Otherwise, it is highly possible that a small obstruction or high spot somewhere around the windshield opening will continue to crack or break the newly installed windshield especially when the strain on the glass caused by this obstruction is increased by such conditions as wind pressures, extremes of temperature, motion of the vehicle, etc.

**NOTE:** The procedure for removal of the windshield applies to other stationary glass applications, such as in figures 20 and 21.

**Removal**

1. Before removing the windshield, mark the location of the break on the windshield rubber channel and the body. Protect the paint finish inside of the cab. Mask around the windshield opening and outside, lay a suitable covering across the hood and fenders.

**NOTE:** The windshield glass rubber weatherstrip is one piece. The glass is held in a channel within the weatherstrip.

2. **On vehicles without reveal moldings**, "unzip" the locking strip shown in figure 18.
3. **On vehicles with reveal moldings**, remove reveal molding with tools shown in figure 19.
4. To free windshield rubber channel of weatherstrip loosen the lip of the windshield weatherstrip from the pinchweld flange along the top and at the sides by applying firm, controlled pressure to the edge of the glass. At the same time assist the lip of the rubber weatherstrip channel over the pinchweld flange with a flat bladed tool. See figures 14 and 15.

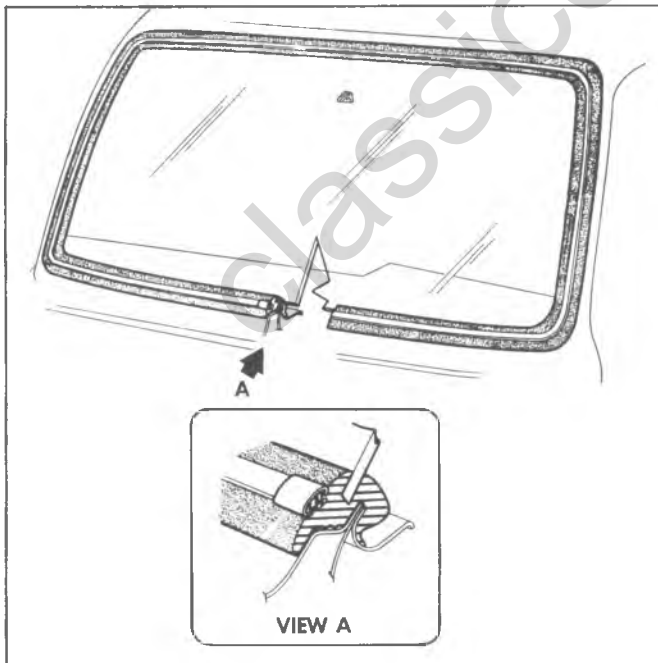

Fig. 13—Typical Windshield



Fig. 14—Applying Pressure to Windshield

5. With the aid of an assistant outside the cab, remove the windshield from the opening. See figure 16.

#### Checking Windshield Opening

Due to the expanse and contour of the windshield it is imperative in the event of a stress crack that the windshield opening be thoroughly checked before installing a replacement windshield. The replacement glass is used as a template.

1. Check for the following conditions at the previously marked point of fracture.
  - a. Chipped edges on glass.
  - b. Irregularities in body opening.
  - c. Irregularities in rubber channel weatherstrip.
2. Check flange area for solder, weld high spots, or hardened spot-weld sealer. Remove all high spots.
3. Check windshield glass to opening, by supporting glass with six spacers contained in packet J-22577. See figure 17.

**CAUTION:** Do not strike glass against body metal. Chipped edges on the glass can lead to future breaks.

4. With the windshield supported and centered in its opening, check the relationship of the glass to the body opening flange around the entire perimeter of the glass.
  - a. Inside edge of glass to body flange.
  - b. Outer edge of glass to parallel body metal.
6. Mark areas of body metal or flange to be reformed remove glass and correct as necessary.
7. Recheck windshield in its opening and if satisfactory proceed as follows.



Fig. 15—Assisting Weatherstrip over Flange



Fig. 16—Removing Windshield from Opening

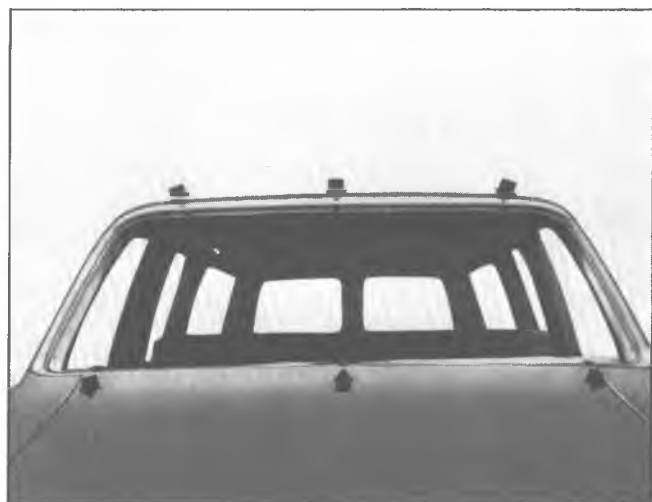

Fig. 17—Checking Windshield Opening

## 1B-8 BODY

### Installation

1. Place a protective covering over front fenders and hood, then apply soapy water to all grooves of the weatherstrip.
2. Install weatherstrip centrally to the body opening, with the pinchweld flange in the inner weatherstrip groove. See figure 18.

**NOTE:** Because of the configuration of the weatherstrip and of the importance of centrally locating the weatherstrip in the body opening, it is **not recommended** to use the "cord-type" installation technique.

3. Position the lower edge of the windshield glass into the outer weatherstrip groove. Gently push the glass "into" the weatherstrip, assisting rubber over edge of glass.
4. When glass is in position, lock the weatherstrip to the glass as follows.
  - a. **Base Weatherstrip**—Bend the "locking strip" over and use a thin bladed tool to lock weatherstrip tightly against windshield. See figure 18 for detail.
  - b. **Optional Weatherstrip**—Use J-2189-24 and J-2189-23 in Handle J-2189 to install flexible reveal molding into locking slot of weatherstrip, as shown in figure 19. This will expand the weatherstrip to a tight fit against the windshield. Install reveal molding so that joint is at center of lower edge of windshield. Cover the joint with the molding cap.

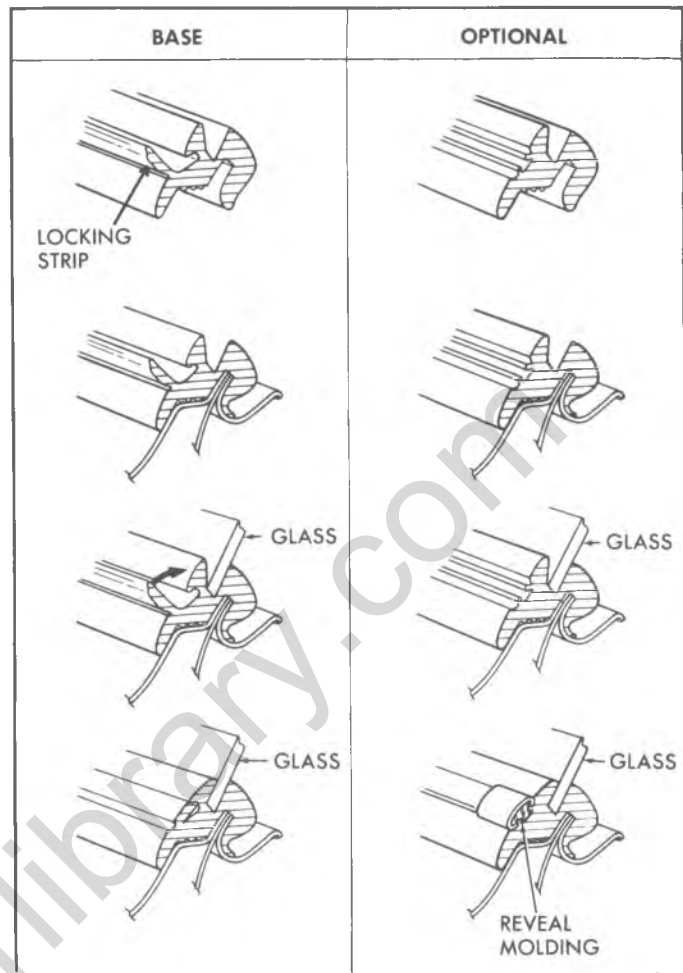

Fig. 18—Locking the Weatherstrip to the Glass



Fig. 19—Installing Reveal Molding

## STATIONARY BODY GLASS

### Replacement

The method used to remove the windshield glass may be applied to other stationary glass, such as shown in figures 20 and 21. Remember to check for cause of breakage, and to always wear gloves when handling glass. Installation procedures are similar to G-Van windshield. Refer to figures 9G and 10G, later in this section.

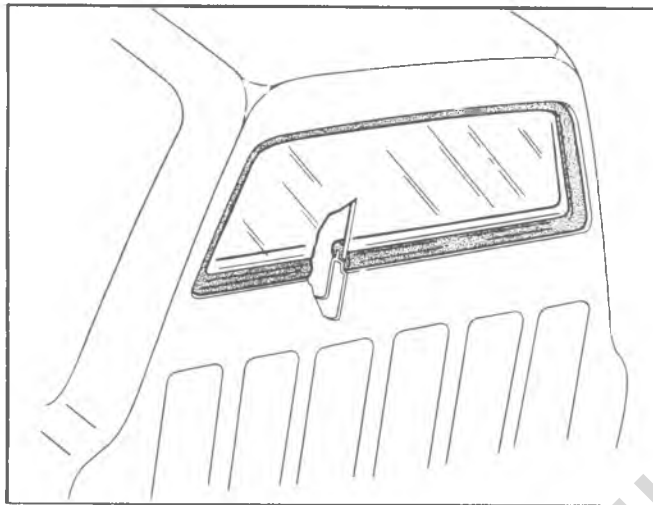

Fig. 20—Back Window Glass—(03, 63)

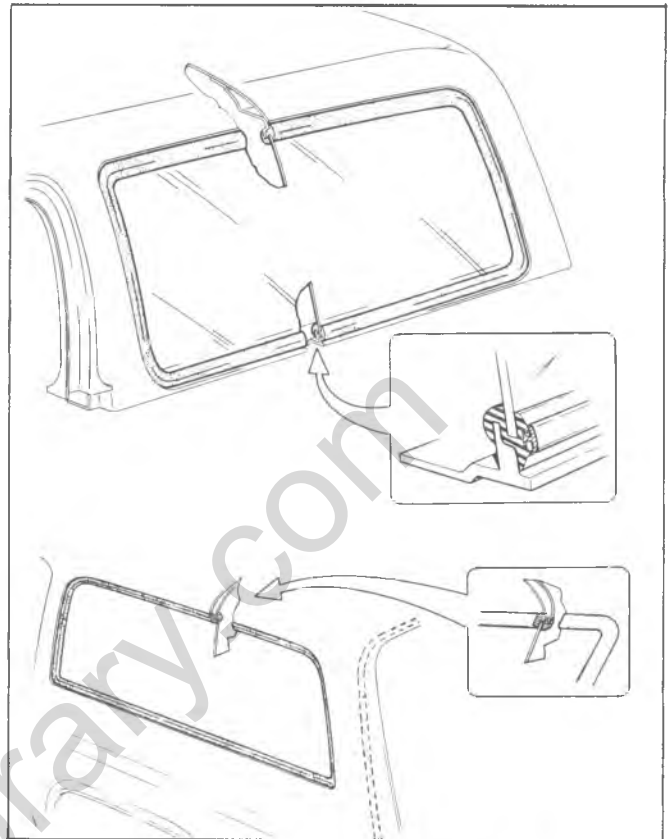

Fig. 21—Body Side Window—(14 and 06)

## BODY SIDE DOORS

### DOOR ADJUSTMENTS

Doors can be adjusted for alignment of clearance in the cab door opening, and for proper latching. Door alignment adjustments are made at the striker bolt, and at door hinges. The door, when properly located in door opening, will have .19 inch clearance at the top and side edges, and .25 inch clearance at the bottom. The door should be adjusted in the opening so the edge of the door across the top and also at the lock side is parallel with the body opening as nearly as possible.

#### Hinge Adjustment

Door hinge bolt holes are oversized to make adjustment possible. Alignment adjustments can be made by loosening the proper hinge bolts, aligning door to proper position, and tightening bolts securely. See figure 22, for typical adjustments.

#### Striker Bolt Adjustment

With the use of J-23457, shown in figure 23, the striker bolt can be adjusted in any of three ways. See figure 24.

1. **Up and down**—To adjust striker up or down, loosen

bolt, adjust to desired height, and tighten bolt securely.

NOTE: This adjustment is important to

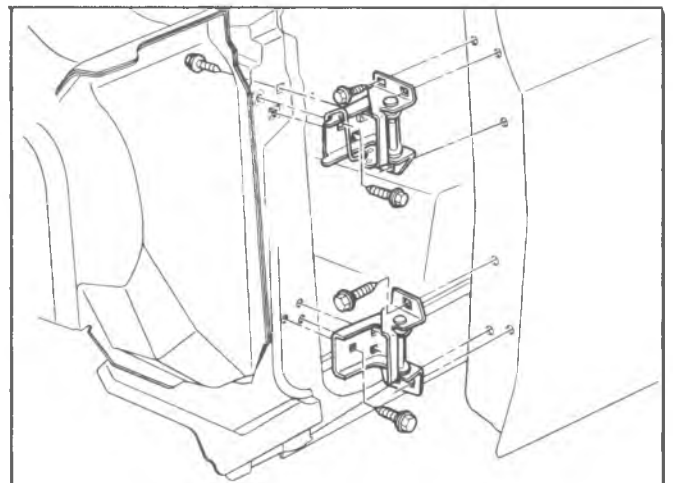

Fig. 22—Door Hinge

## 1B-10 BODY

assure that the right proportion of door's weight will rest on striker bolt when door is closed. If bolt is positioned too high on pillar, rapid wear will occur to the lock cam; if too low, an extra load will be placed on door hinges as well as pull door downward and out of alignment.

2. **In and Out**—To adjust striker in and out, loosen bolt, adjust horizontally to desired position and tighten bolt securely.
3. **Forward and Rearward**—To make this adjustment, loosen striker bolt, shim to desired position, and tighten bolt securely.

## FRONT DOOR ASSEMBLY

### Replacement

Remove the door assembly from the body by removing the hinges from the door.



Fig. 23—Loosening Striker Bolt

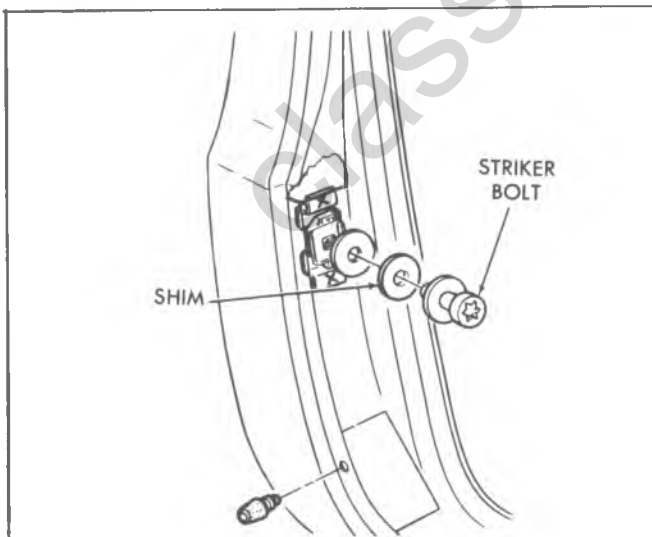

Fig. 24—Typical Striker Bolt Adjustment

## DOOR HINGE

The door check is part of the front door upper hinge. The front door torque rod check holds the door in either of two positions between full open and closed. The front door check-hinge assembly is replaced as a complete unit as follows. See figure 22.

### Removal

1. Loosen front fender rear bolts.
2. With special Tool J-22585 remove 3 bolts securing front door upper hinge to cowl pillar.
  - a. Remove the door to upper hinge retaining bolts.
  - b. With aid of an assistant to support weight of door, remove the door to lower hinge retaining bolts and remove door.

### Installation

1. Install hinge snugly on pillar in same location as hinge removed.
2. With the aid of an assistant fasten the door to the hinge.
3. Adjustment of the door lock and striker plate should be made after the door is positioned in the opening.

## DOOR VENTILATOR ASSEMBLY—FIG. 25

### Removal

**NOTE:** The channel between the door window glass and door vent is removed as part of the vent assembly.

1. Regulate the door window glass to the full down position.
2. Remove clip from the window regulator handle, and knob from lock rod.

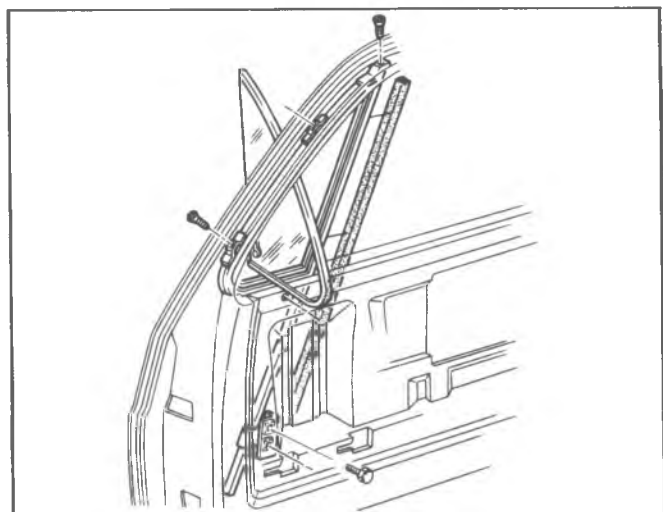

Fig. 25—Door Ventilator Assembly

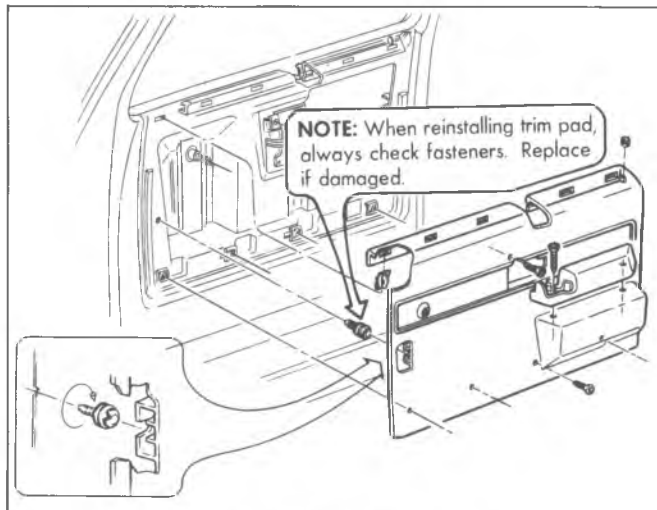

Fig. 26—Door Trim Pad

3. Remove arm rest screws and trim panel. See figure 26.
4. Remove screws attaching ventilator lower assembly to door panel.
5. Loosen inner to outer panel attaching screw through access hole just rearward of the lower vent pivot.
6. Slide door window glass rearward away from ventilator.
7. Remove three screws at the upper front of the door frame.
8. Turn vent assembly 90° and carefully remove by guiding up and out. See figure 27.

#### Ventilator Glass Replacement

1. Using an oil can or similar means, squirt prepsol or equivalent on the glass filler all around the glass



Fig. 27—Removing Ventilator Assembly

channel or frame to soften the old seal. When the seal has softened, remove the glass from the channel.

2. Thoroughly clean the inside of the glass channel with sandpaper, removing all rust, etc.
3. Using new glass channel filler, cut the piece to be installed two inches longer than necessary for the channel. Place this piece of filler (soapstoned side of filler away from glass) evenly over the edge of the glass which will fit in the channel. The extra filler extending beyond the rear edge of the glass should be pinched together to hold it in place during glass installation.

NOTE: One side of this filler (the outside of the roll) is soapstoned. This is the side which goes into the metal channel.

4. Brush the inside of the metal glass channel freely with ordinary engine oil. This will enable the glass and filler to slide freely into the channel. Push the glass with the filler around it into the channel until it is firmly seated. After the glass is firmly in place, the oil softens the filler, causing it to swell, thereby making a watertight seal. Trim off the excess filler material around the channel and at the ends of the channel.

NOTE: Glass should be installed so that rear edge is parallel to the division post. Allow full cure before water testing.

#### Installation

NOTE: Replace the door window glass and regulate to the full down position before installing the door ventilator assembly.

1. Lower the ventilator assembly into the door frame.
2. Make certain the rubber lip is positioned inside the inner and outer panel before tightening screws.
3. Slide door glass forward engaging glass in vent channel.
4. Reinstall all screws and tighten.
5. Install and tighten the three screws at the upper front of the door.

#### Adjustment

1. Adjust the ventilator by placing wrench on adjusting nut thru access hole and **turning vent window** to the desired tension. See figure 28.
2. After making adjustment bend tabs over the hex nut on base of assembly. See figure 29.
3. Install arm rest screws and trim panel.
4. Install window regulator handle.

#### DOOR WINDOW ASSEMBLY—FIG. 30

##### Replacement

1. Completely lower glass to bottom of door.



Fig. 28—Adjusting Tension



Fig. 30—Door Window and Regulator

2. Remove window regulator handles using tool J-7797, and remove remote control push button knob.
3. Remove door arm rest and trim pad.
4. Mask or cover upper portion of door window frame. Remove ventilator assembly as previously outlined.
5. Slide glass forward until front roller is in line with notch in sash channel. Disengage roller from channel.
6. Push window forward and tilt front portion of window up until rear roller is disengaged. See figure 31.
7. Put window assembly in normal position (level) and raise straight up and out.
8. Reverse above procedure for installation.

### WINDOW REGULATOR—FIG. 30

#### Replacement

1. Remove ventilator assembly and door window as outlined previously.
2. Remove screws attaching regulator to door inner panel.
3. Remove regulator assembly through door opening.
4. Install regulator by reversing above steps. Lubricate regulator gear with lubriplate or equivalent.

### LOCKS, HANDLES AND RODS

The door lock, handles and control rods are shown in figure 32 as they would be installed in the vehicle. Note the clips which attach the three control rods to the lock assembly.

**NOTE:** All clips which attach control rods to lock assembly must be replaced whenever removed.



Fig. 29—Bend Tabs Over Hex Nut

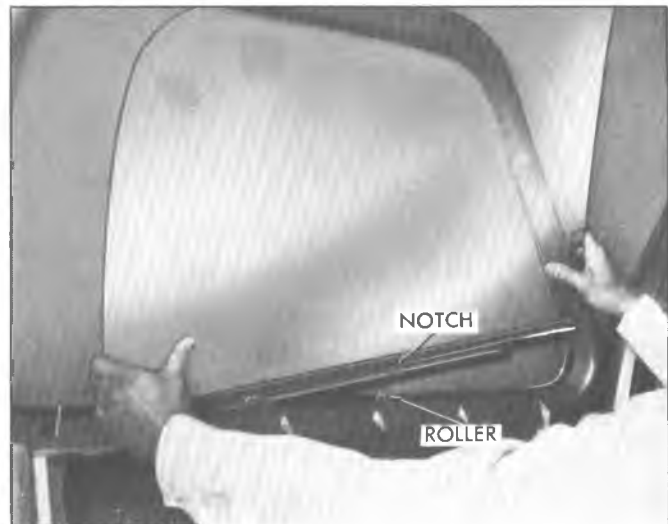

Fig. 31—Removing Door Glass



## Door Lock Assembly

### Replacement

1. Raise window to gain access to lock.
2. Remove regulator handle.
3. Remove remote control push button knob.
4. Remove trim panel.
5. Remove clip from inside handle rod-to-lock.
6. Remove clip from outside handle rod-to-lock. This is best accomplished by inserting a long screwdriver through the daylight opening, as shown in figure 32.
7. Remove screws which attach lock assembly to door panel.
8. Remove lock and remote control rod as an assembly.
9. To install lock assembly, reverse above steps. Be sure to replace all clips removed earlier.

## Door Outside Handle—Fig. 33

### Replacement

1. Raise window to gain access to lock.
2. Remove window regulator handle.
3. Remove remote control rod.
4. Remove trim panel.
5. Remove clip from outside handle rod-to-lock. This is best accomplished by inserting a long screwdriver through the daylight opening, as shown in figure 32.
6. Remove screws which retain outside handle to door panel.
7. Remove handle and control rod.
8. Reverse above procedures to install outside handle.

## Door Lock Cylinder—Fig. 33

### Replacement

1. Raise door window.

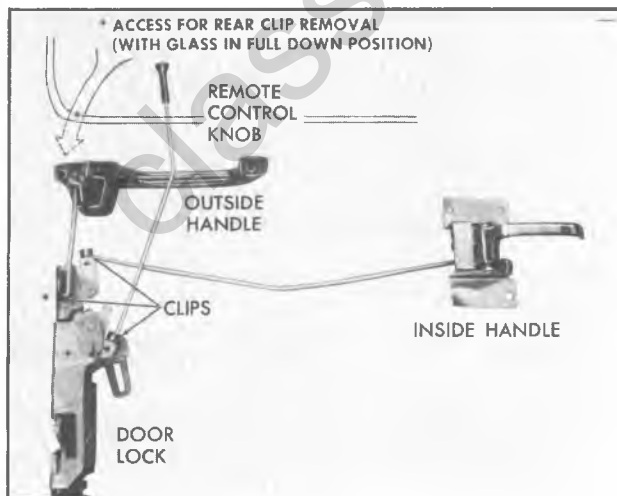

Fig. 32—Lock, Handles and Rods

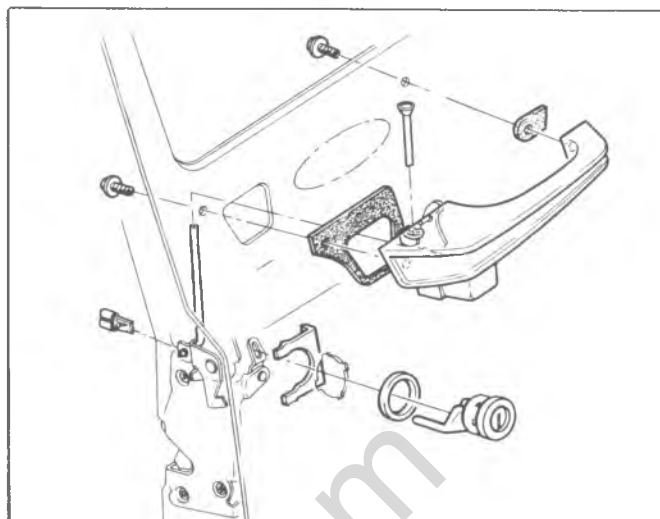

Fig. 33—Outside Handle and Lock Cylinder

2. Remove window regulator handle, remote control knob and trim panel.
3. Use a screwdriver or other suitable tool to slide the lock cylinder retaining clip out of engagement with the lock cylinder.
4. Remove lock cylinder.
5. To install, reverse the above steps.

## Door Inside Handle

### Replacement

1. Remove window regulator handle, remote control push button knob and trim panel.
2. Disconnect control rod from inside handle, as shown in figure 34.
3. Remove screws retaining inside handle to door.
4. Remove inside handle.
5. Reverse above steps to install.

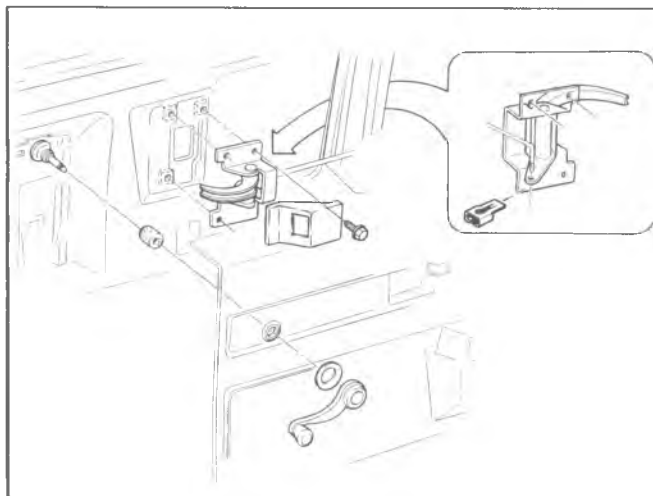

Fig. 34—Inside Handle

## DOOR TO BODY OPENING WEATHERSTRIP—FIGS. 35, 36

Side door sealing incorporates an inner seal. The inner seal is mounted on the body opening welding flange and goes completely around the periphery of the opening. The molded weatherstrip material is snapped in place.

Success of weatherstrip replacement depends entirely upon the quality of the cement used and the care with which it is applied. All rust, road dirt and grease or oil must be completely removed as should all old cement and bits of old weatherstrip. After removing all foreign material from door opening surface proceed as follows:

1. Open door and block open.
2. Remove sill plate retaining screws and remove sill plate.
3. Remove side door inner weatherstrip seal.
4. Install molded corner of inner weatherstrip, starting at the bottom of the door opening.
5. Trim inner weatherstrip with a notch and butt ends together.
6. Reinstall sill plate and sill plate retaining screws.

## REAR SIDE DOOR (06 AND 63 ONLY)

### Adjustments and Hinge Replacement

The procedures for hinge replacement, and for hinge and striker bolt adjustment are similar to those detailed in the front door adjustment procedure. Access to the hinges of the rear door is shown in figure 37.

## STATIONARY GLASS—REAR DOOR

### Replacement

1. Lower window to full down position.
2. Remove remote control knob and window regulator handle.

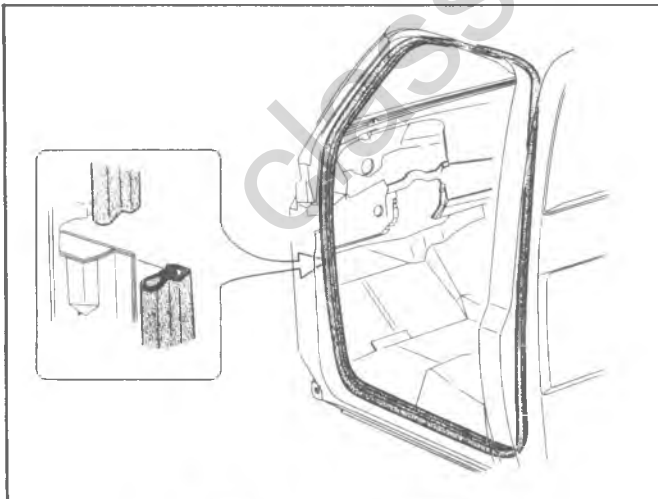

Fig. 35—Door Weatherstrip (03-63-06)

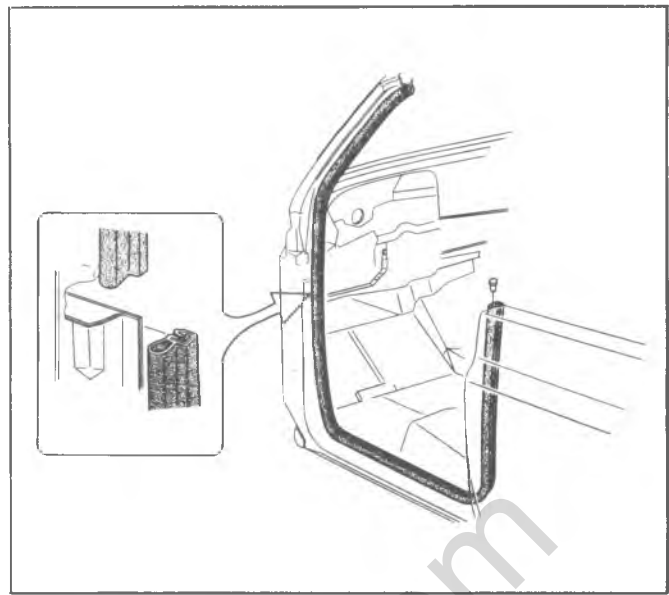

Fig. 36—Door Weatherstrip (14)

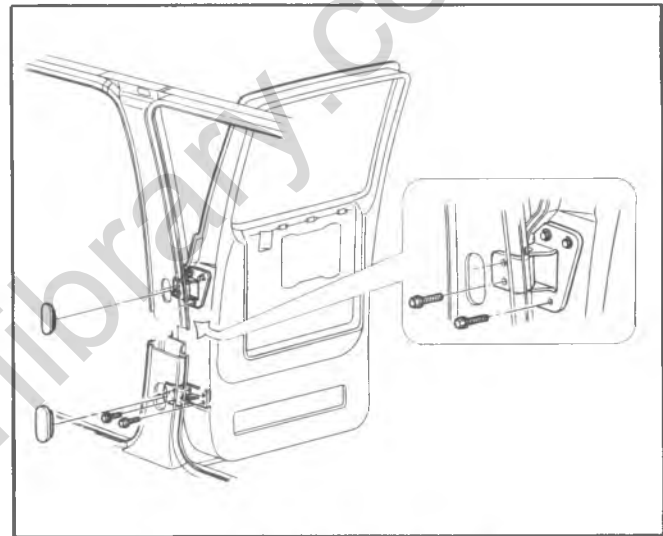

Fig. 37—Rear Door Hinge Location

3. Remove screws retaining door trim pad, and remove trim pad. See figure 38.
4. Remove glass run channel by removing screws retaining channel to door. See figure 39.
5. Remove stationary glass.
6. Replace glass by reversing above procedure.

## WINDOW GLASS—FIG. 40

### Replacement

1. Lower glass to full down position.
2. Remove remote control push button knob, window regulator handle and trim pad.
3. Remove stationary glass as previously outlined. Remove screws from rear division channel, and slide channel rearward in the opening.
4. Raise glass as far as possible, then slide glass until the roller is in line with the notch in the sash

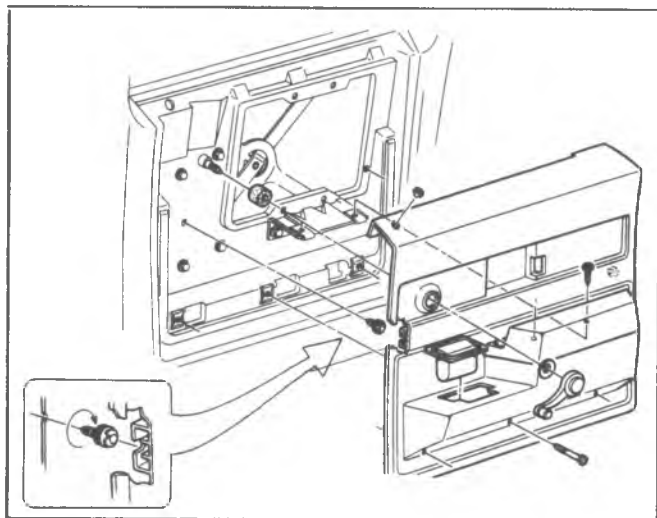

Fig. 38—Side Rear Door Trim Pad

- channel. See figure 40. Disengage roller from channel.
5. Tilt window outboard and move until other roller can be removed from channel.
6. Raise window up and out.
7. Reverse above procedure for installation.

### WINDOW REGULATOR ASSEMBLY—FIG. 40

#### Replacement

1. Remove trim pad, stationary glass, and window glass as outlined earlier.
2. Remove screws attaching regulator assembly to door inner panel.
3. Remove regulator assembly through opening in door.

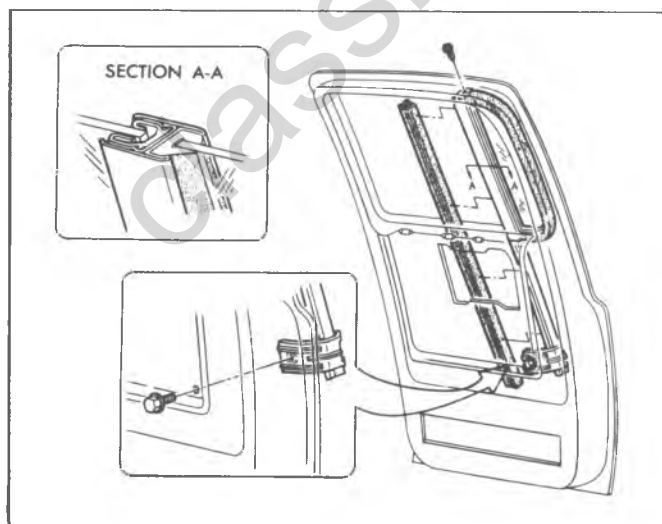

Fig. 39—Glass Run Channel

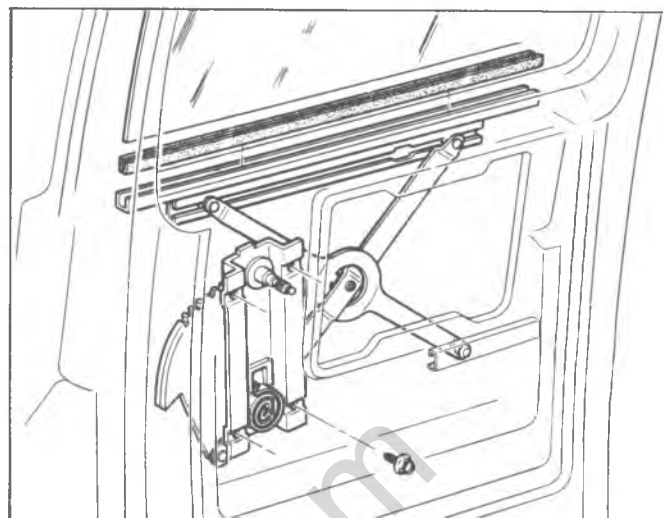

Fig. 40—Window Glass and Regulator Assembly

4. Install regulator by reversing above procedure. Lubricate regulator gear with lubriplate or equivalent.

### LOCKS, HANDLES AND RODS

#### Lock Assembly—Fig. 41

##### Replacement

1. Remove window regulator handle and remote control push button knob.
2. Remove trim pad.
3. Disengage three clips which retain control rods to lock assembly.
  - a. Inside handle control rod.
  - b. Remote control lower rod.
  - c. Outside handle control rod.
4. Remove screws retaining lock assembly to door panel, then remove lock assembly.
5. Install lock by reversing above procedure. Be sure to replace all clips removed with new clips on installation.

#### Inside Handle—Fig. 41

##### Replacement

1. Remove regulator handle, remote control knob and trim pad as outlined previously.
2. Disconnect control rod from inside handle by removing clip as shown in figure 41.
3. Remove inside handle by removing four screws which secure handle to door panel.
4. Replace handle by reversing above procedure. Install new clip when installing control rod.

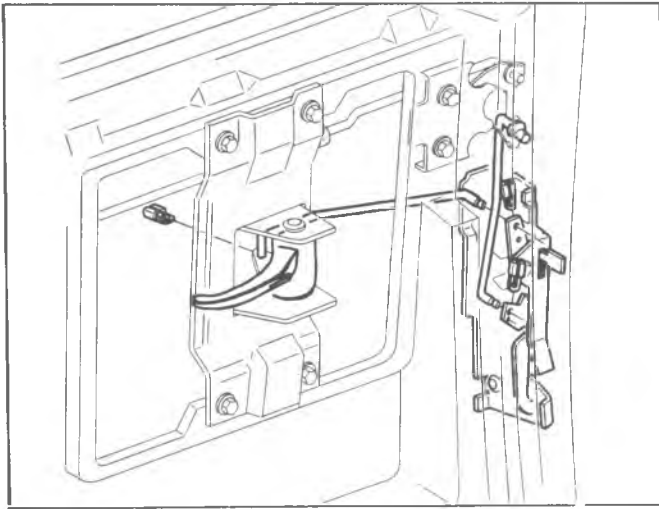

Fig. 41—Lock Assembly and Inside Handle

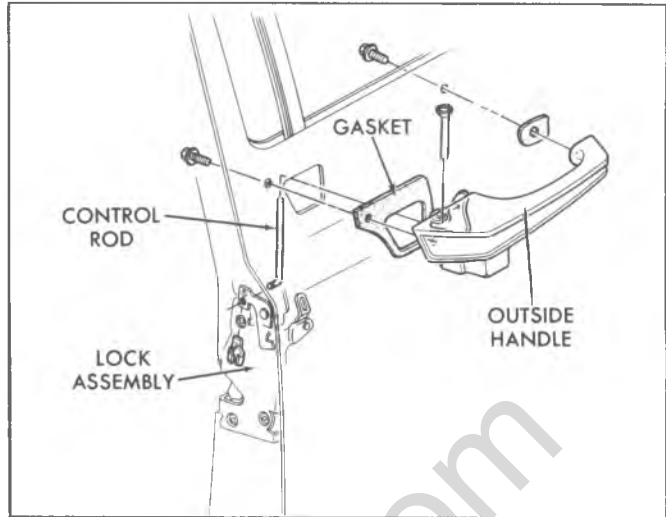

Fig. 43—Outside Handle

**Remote Control—Fig. 42**

**Replacement**

1. Remove regulator handle, remote control knob and trim pad.
2. Disconnect remote control lower rod from door lock assembly.
3. Remove two screws securing each remote control lever to door panel.
4. Remove remote control levers and rods through door opening.
5. Replace by reversing above procedure.

3. Remove two screws securing outside handle to door panel.
4. Remove handle assembly.
5. Replace by reversing above procedure. Be sure to use new clip when attaching control rod to lock assembly.

**Outside Handle—Fig. 43**

**Replacement**

1. Remove regulator handle, remote control rod and trim pad.
2. Disengage outside handle control rod from lock assembly by removing clip, as shown in figure 43.

**WEATHERSTRIP—FIG. 44**

The procedure outlined in Front Door Weatherstrip may be applied to the Rear Side Door Weatherstrip, shown in figure 44.

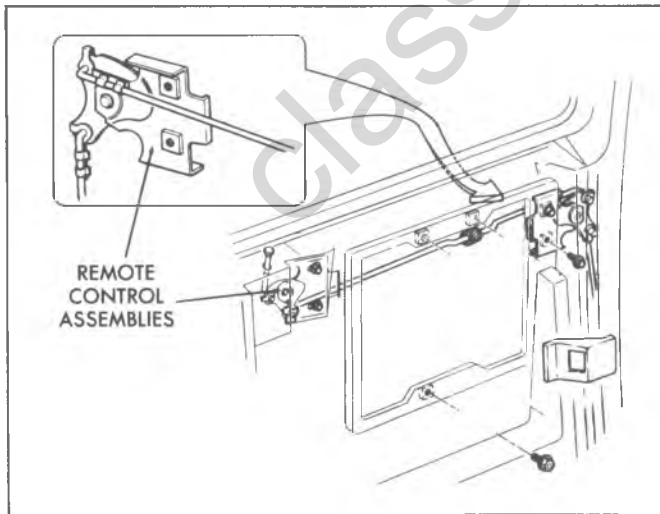

Fig. 42—Remote Control Assembly

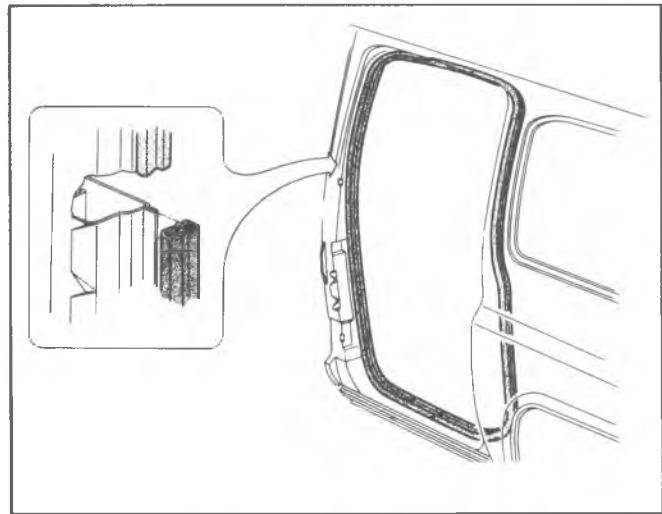

Fig. 44—Side Rear Door Weatherstrip

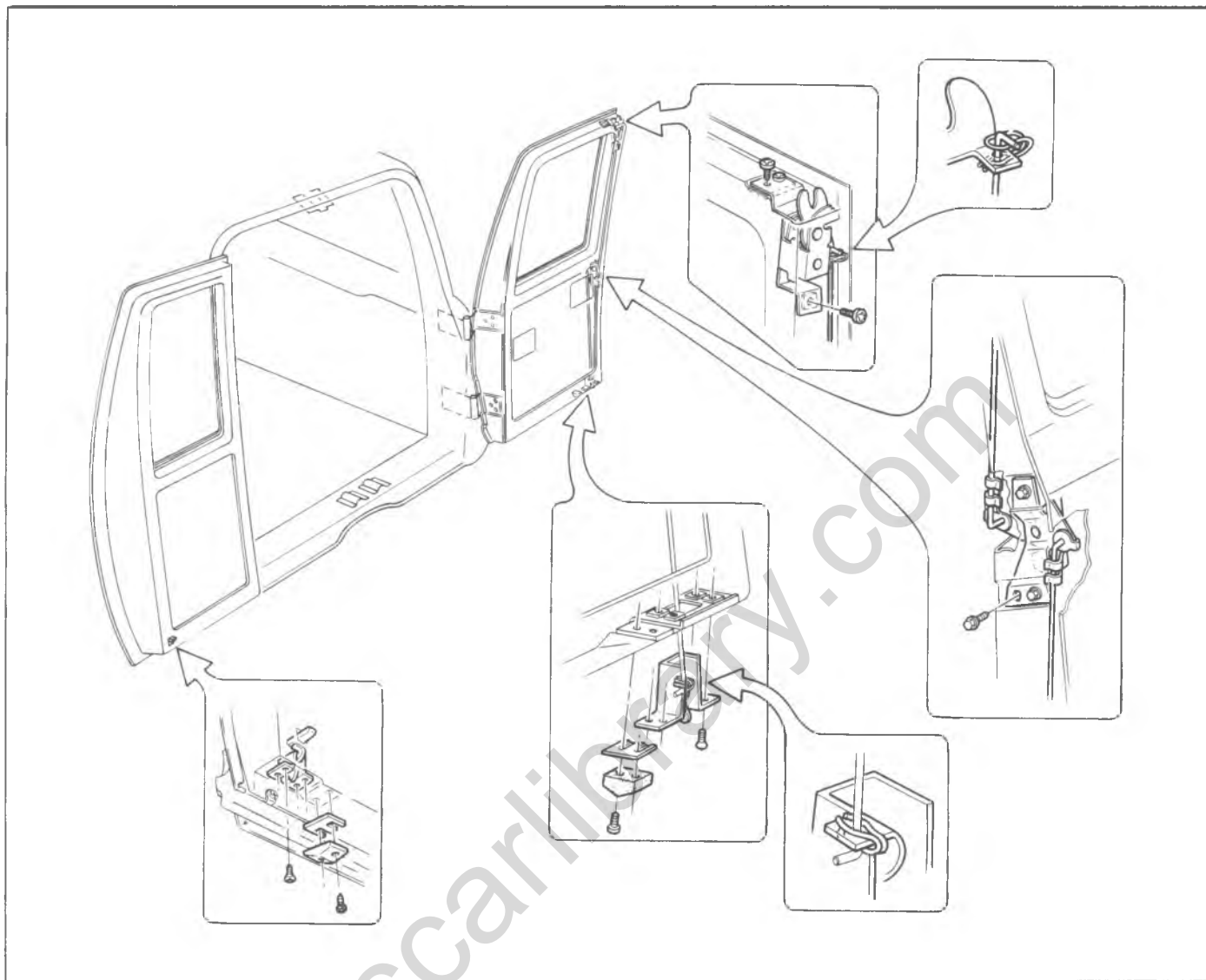

Fig. 45—Rear Door Controls

**REAR DOORS (06 ONLY)**

**Adjustments**

Rear doors may be adjusted in the body opening by loosening hinge bolts and repositioning door, then retightening bolts. See figure 47 for hinge bolt location. Rear door wedges and strikers should be adjusted as shown in figure 48.

**LOCKS, HANDLES AND RODS**

The rear door lock, outside handle, lock cylinder, control rods and latch are shown in figures 45 and 46. The rods can be disconnected from the lock, latch or handle by disengaging the retaining clips, as shown. The lock cylinder is removed in the same manner as the front side door lock cylinder.

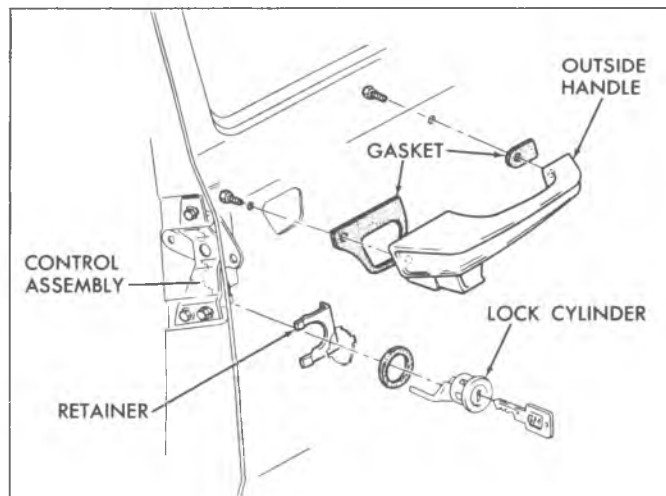

Fig. 46—Rear Door Outside Handle and Lock Cylinder

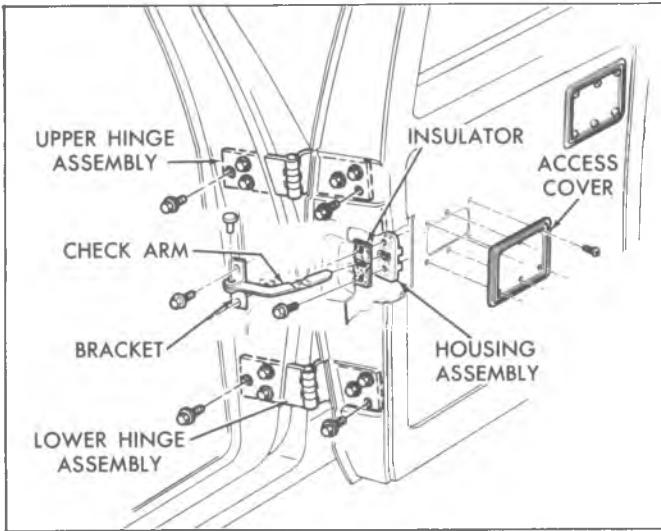

Fig. 47—Rear Door Hinges and Check Arm

**REAR DOOR—FIG. 47**

**Replacement**

1. Remove bolts securing check arm bracket to body pillar.
2. Remove upper and lower hinge bolts, and with aid from an assistant, remove the rear door.
3. Reverse above steps for reinstallation.

**CHECK ARM—FIG. 47**

**Replacement**

1. Remove bolts securing check arm bracket to body pillar.

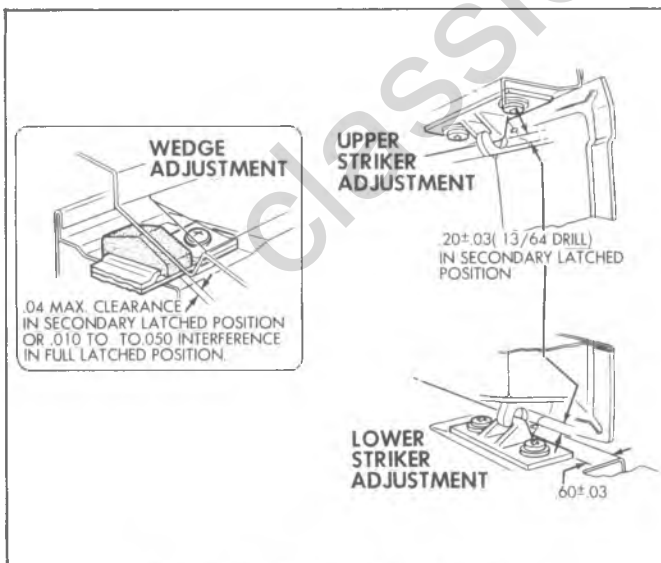

Fig. 48—Wedge and Striker Adjustments

2. Remove check arm access cover.
3. With one hand supporting housing assembly and insulator on the inside of the door panel, remove bolts securing housing assembly to door.
4. Remove housing, insulator and check arm.
5. To separate check arm from bracket, remove holding pin connecting the two parts.
6. To install check arm, reverse the procedure above.

**WEATHERSTRIP**

Weatherstrip installation is shown in figure 49. Proper installation is dependent on completely cleaning all foreign material from old installation and using a quality cement on the new installation.

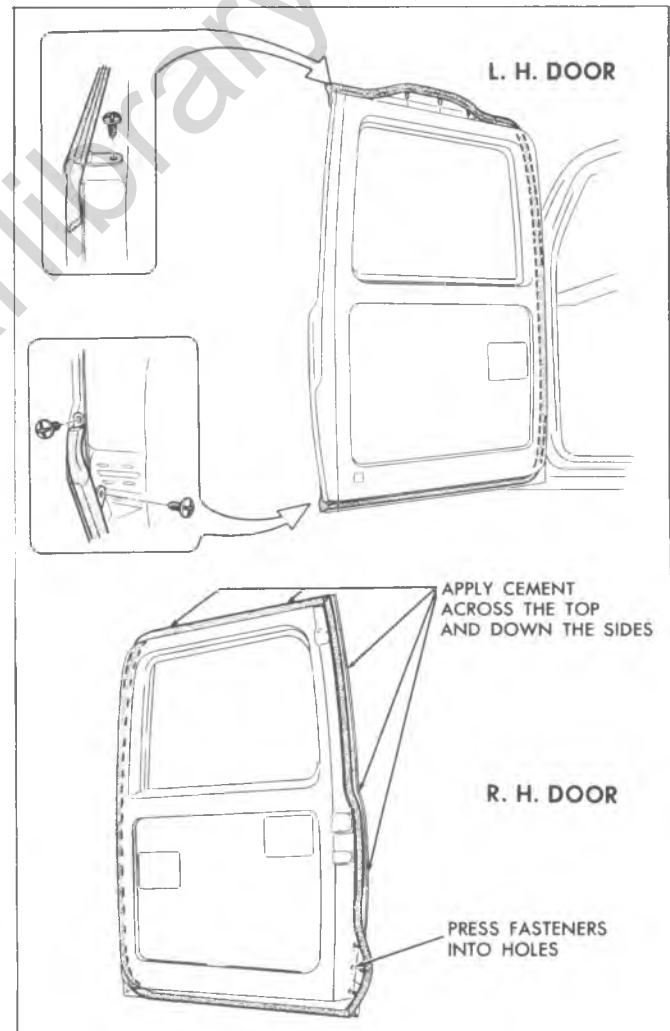

Fig. 49—Weatherstrip—L.H. and R.H. Rear Door

## ENDGATES (06 AND 14)

Coach models (06) and utility models (14) use endgates of similar, yet distinct design. Separate procedures follow for service on each of these endgates.

### ENDGATE ASSEMBLY—

#### (06) MODELS ONLY

##### Replacement

1. Lower endgate, and remove hinge access covers. See figure 50.
2. Remove endgate-to-hinge bolts.
3. Remove L.H. torque rod bracket, shown in figure 51.
4. If equipped with electric powered window, disconnect wiring harness.
5. Lift endgate to almost closed position and remove support cables.
6. Remove endgate with torque rod.
7. To install, reverse removal procedure.

### HINGES

#### Replacement

If necessary to remove hinges, remove endgate as outlined previously, and proceed as follows:

1. Remove bolts from each of the hinge assemblies on the underside of the body. See figure 50.
2. Remove hinge assemblies. If the hinge pins are to be removed, note the position of bushings so they may be reinstalled in the same position.
3. Reverse procedure to install.

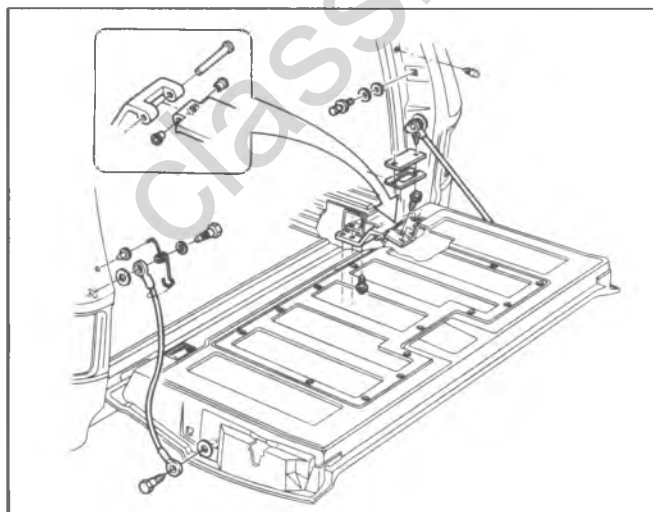

Fig. 50—Endgate, Hinges and Supports—(06 Only)

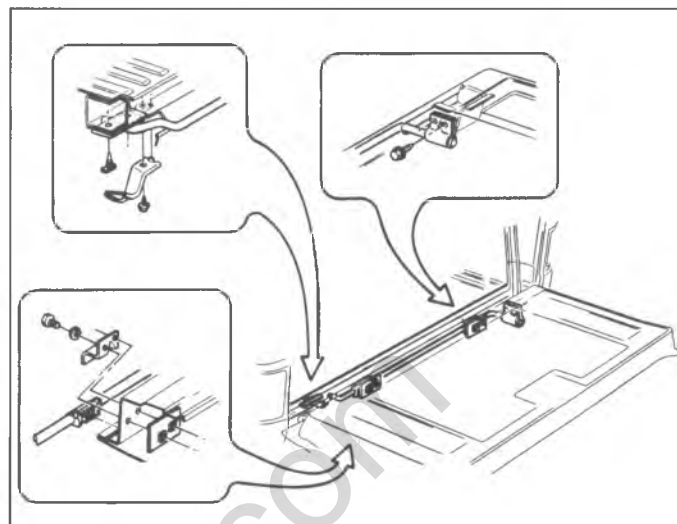

Fig. 51—Torque Rod—(06 Only)

### ENDGATE DISASSEMBLY

1. Remove access cover shown in figure 52, to gain access to interior components.
2. Detach remote control rods from lock assembly by removing clips.
3. Remove bolts securing lock assembly, and remove lock assembly.
4. Remove handle assembly bolts and remove inside handle.
5. Remove R.H. torque rod bracket screws, figure 51, then remove torque rod from endgate.
6. Remove screws connecting cam assemblies to sash assembly, figure 53, then remove cam assemblies.
7. Remove glass from endgate.

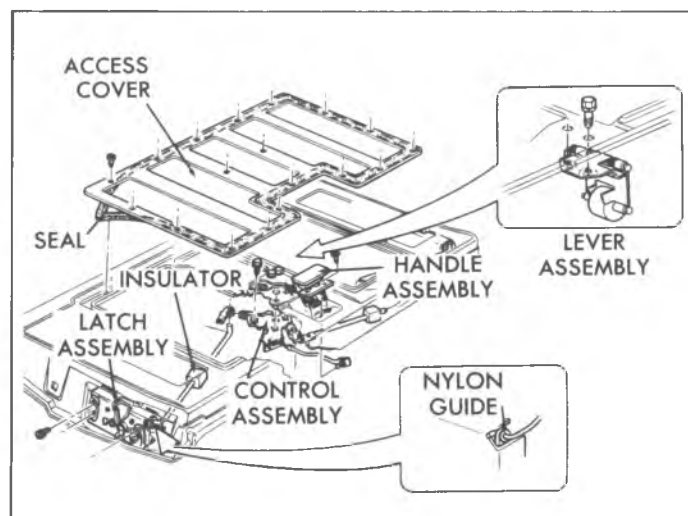

Fig. 52—Latch and Remote Controls—(06 Only)

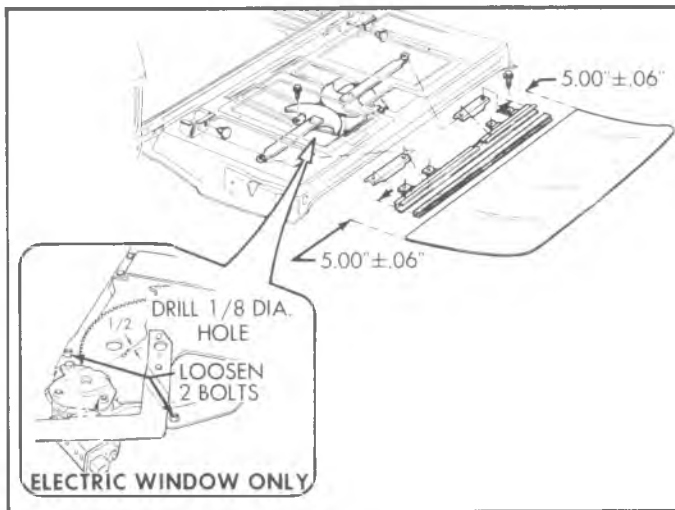

Fig. 53—Window Glass and Regulator—(06 Only)

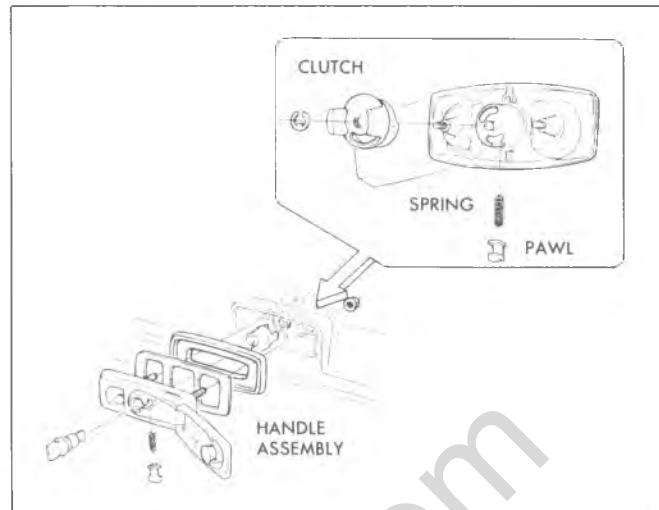

Fig. 54—Outside Handle (06 and 14)

8. Unclip and remove inner and outer seal assemblies.
9. Remove screws connecting window regulator assembly to endgate, figure 53, and remove regulator.
10. For endgates with electric window, secure the window regulator lift arms before removing the electric motor, when the window glass has been removed or disengaged from the lift arms.
  - a. Drill a 1/8 inch hole through the sector gear and back plate, as shown in figure 53. Install a sheet metal tapping screw into the hole to lock the sector gears in position.
  - b. Remove the regulator motor attaching screws and remove the motor assembly.
11. From inside the endgate, remove the nuts fastening the outside handle to endgate and remove the outside handle. See figure 54.

NOTE: If equipped with power tailgate window, detach wiring harness from motor.

12. Remove side bolts connecting left and right glass channels to endgate and remove channels.
13. Remove side latch bolts and remove side latches with control rods. See figure 52.

NOTE: Detach wiring harness from R. H. latch if so equipped.

14. Separate side latch from control rod by pulling control rod thru nylon guide.
15. Reverse the above procedure for reassembly and installation.

#### Adjustments

Loosen bolts, adjust at either endgate hinge position or endgate latch, then retighten bolts.

#### ENDGATE ASSEMBLY—

#### (14) MODELS ONLY

#### Replacement

1. Lower endgate, then remove four bolts securing hinge to body on each side. See figure 55. Disconnect wiring harness, if so equipped.
2. Disconnect torque rod anchor plate on each side. It is necessary to remove lower bolt only, then let plate swing down. See figure 59.
3. With an assistant, raise endgate part way, then

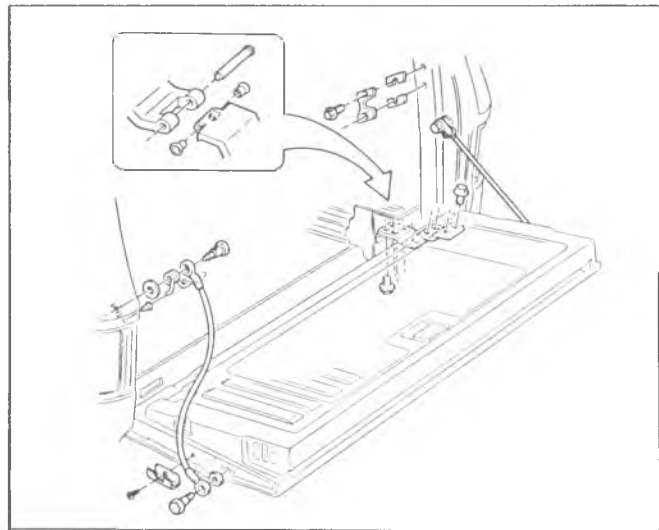

Fig. 55—Endgate, Hinges and Support (14)



disconnect support cables from endgate. See figure 55.

4. Remove endgate by pulling disconnected hinge from body, figure 56, then grasping torque rod with one hand and pulling torque rod over gravel deflector, as shown in figure 57.
5. Individual components may be removed from the endgate now, or after reinstallation.
6. To install endgate, reverse the above procedure.

## HINGE

### Replacement

1. Lower endgate and disconnect hinge to be replaced by removing hinge-to-body bolts. See figure 55.
2. At the other hinge, **loosen** the hinge-to-body bolts.
3. On the hinge to be replaced, remove the hinge-to-endgate bolts.



Fig. 56—Pulling Hinge Away From Body (14)



Fig. 57—Grasping Torque Rod (14)



Fig. 58—Removing Access Cover (14)

4. Pull the endgate away from the body several inches and withdraw hinge from body. Then lift endgate slightly to allow removal of hinge from endgate. See figure 56.
5. To install hinge, reverse the above procedure. Be sure to install hinge into endgate first, then into the body.

## TORQUE ROD

### Replacement

1. Lower endgate and remove access cover, as shown in figure 58.
2. Disconnect torque rod anchor plate. It is necessary to remove the lower bolt only, then let plate swing down. See figure 59.
3. Loosen four bolts retaining endgate hinge to body.
4. Move endgate slightly away from body.

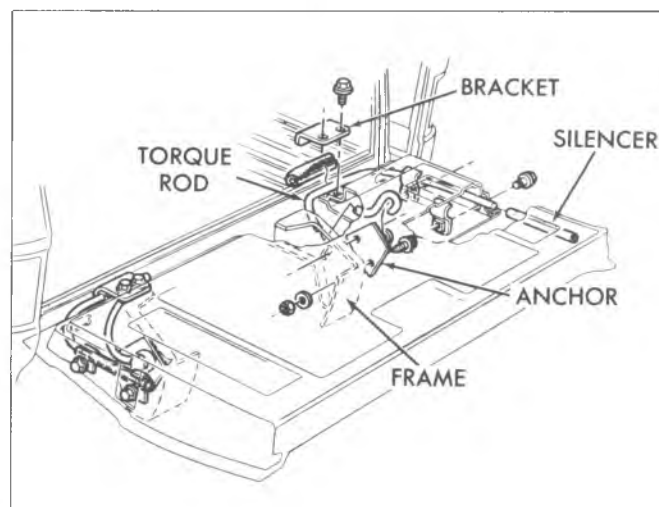

Fig. 59—Torque Rod Installation (14)

5. Remove torque rod retaining bracket on lower edge of endgate. See figure 59.
6. Remove torque rod retaining clip on side edge of endgate.
7. Lift torque rod up and slide from endgate as shown in figure 60.
8. Reverse the procedure above for installation.

**ENDGATE DISASSEMBLY**

1. Lower endgate and remove access cover.
2. Disconnect side latch remote control rods from center control by removing retaining clips. See figure 61.
3. Remove four screws from each side latch, and withdraw latch and control rod from endgate, as shown in figure 62.
4. Disconnect control rod from latch.

5. Refer to figure 63 for installation of latch control and blackout rod.
6. Disconnect blackout rod from control assembly by detaching spring and removing two screws retaining rod to inner panel.
7. Disconnect inside handle control rod from control assembly, then remove screws which secure inside handle to inner panel.
8. Remove three screws which retain remote control assembly to inner panel.
9. Remove control assembly and inside handle as shown in figure 64.
10. Refer to figure 65 for window and regulator installation.
11. Roll window to up position.
12. Disconnect sash from regulator as shown in figure 66.



Fig. 60—Removing Torque Rod (14)

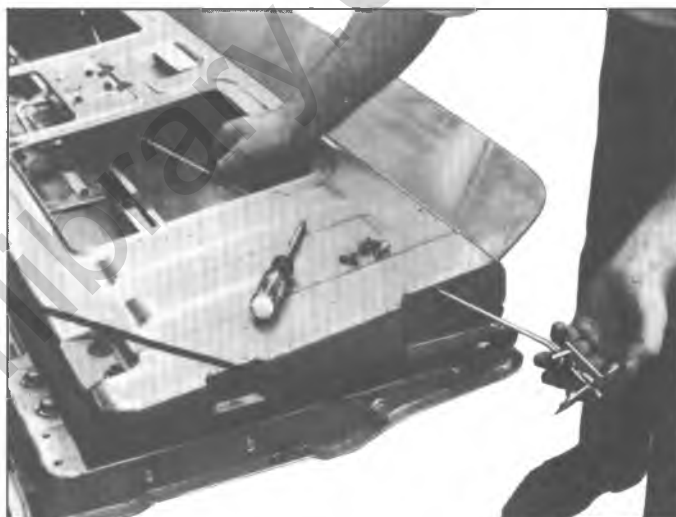

Fig. 62—Removing Side Latch

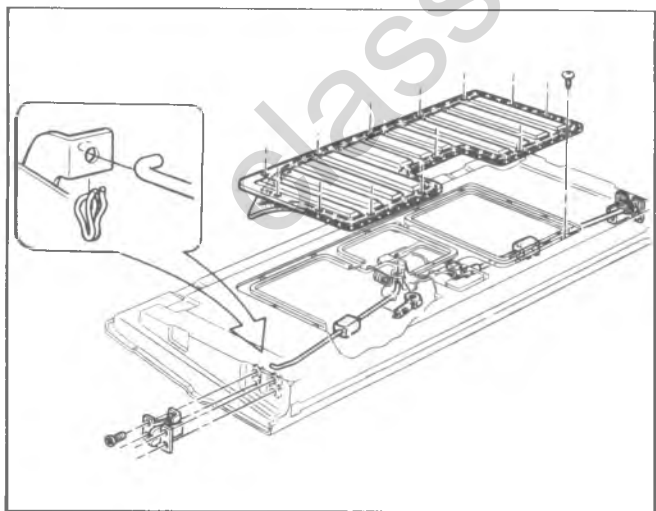

Fig. 61—Latches and Rods

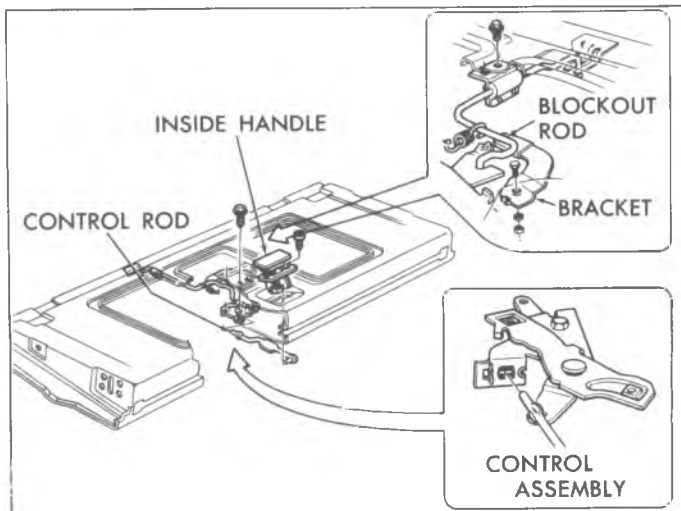

Fig. 63—Control Assembly and Blockout Rod



Fig. 64—Removing Control Assembly and Inside Handle

13. Remove glass from endgate.
14. Remove four regulator attaching screws and withdraw regulator from endgate as shown in figure 67.
15. Remove outside handle by removing nuts from inside of outer panel. See figure 68.
16. Reverse the above steps for reassembly.

### TAILGATES (03, 63 and 14)

#### Replacement

Utility vehicles (14) without removable tops utilize a tailgate shown in figure 69. Chassis/cab (03 and 63) models have optional pickup units which utilize tailgates as shown in figures 69 and 70.

The tailgate shown in figure 69 can be removed by disconnecting both links from the tailgate, removing

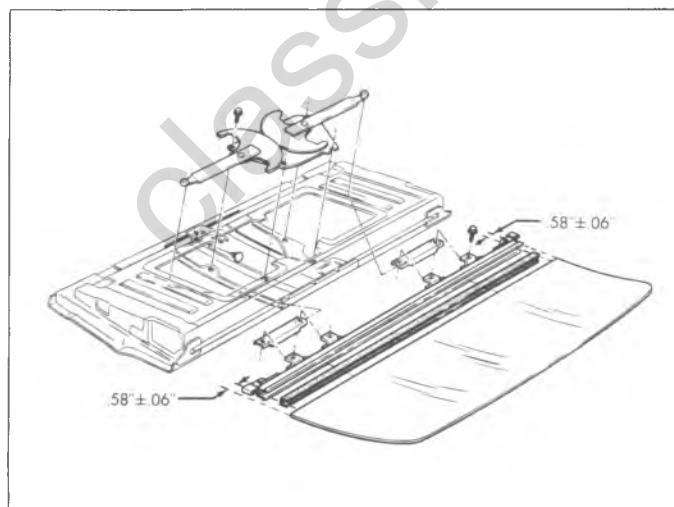

Fig. 65—Window and Regulator

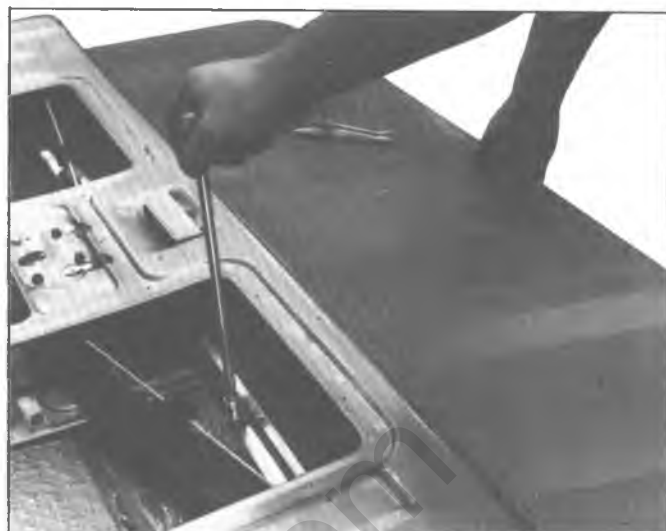

Fig. 66—Disconnecting Sash from Regulator



Fig. 67—Removing Regulator

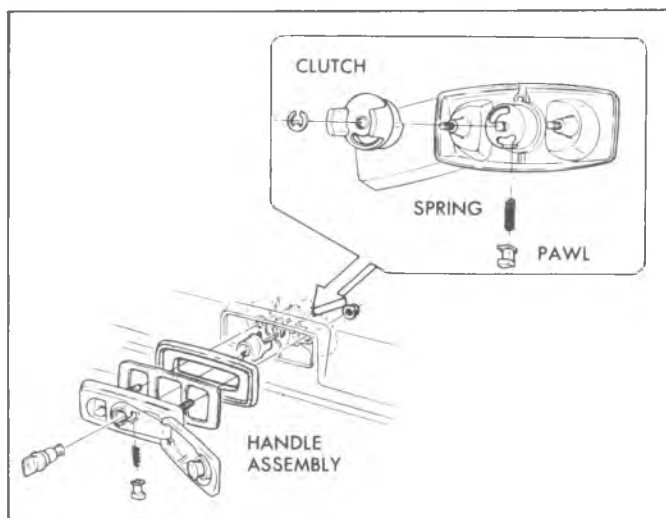

Fig. 68—Outside Handle

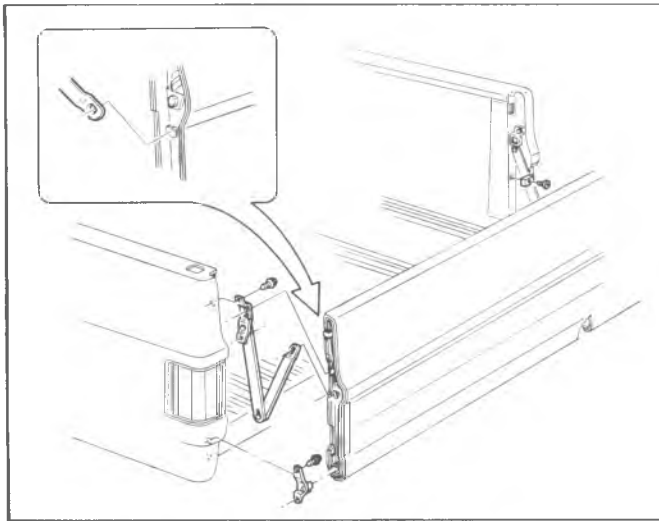

Fig. 69—Tailgate (14, 03 and 63)

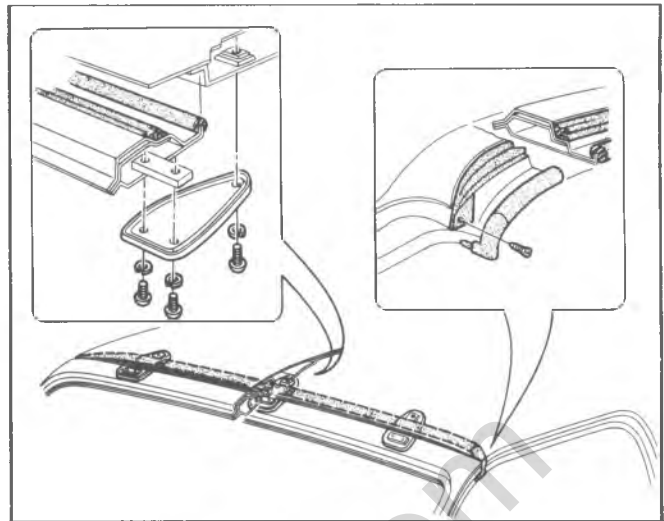

Fig. 71—Roof-to-Header Brackets

screws attaching both trunnions to body, and lifting the tailgate off the vehicle.

The tailgate shown in figure 70 can be separated from the vehicle by removing the bolt and lock washer from each trunnion in carrier box, and removing the tailgate.

## REMOVABLE TOP (14 ONLY)

### Removal

1. Remove the bracket-to-roof bolt from each of the top-to-header panel attaching brackets as shown in Figure 71.
2. Remove the bolts which retain the top to the body side panels, shown in figure 72.
3. Lower the rear window into the endgate, and lower endgate.
4. Lower the door windows.
5. Slide top rearward approximately 18" to expose the bottom rear top-to-pickup box attaching holes.
6. To prevent possible flexing of the sides on removal, connect the sides of the top with support braces as follows.
  - a. Fabricate 2 braces 72" long from wood or square aluminum tubing. Drill two (2) 3/8" diameter holes, 63 inches apart in the brace.
  - b. Attach one brace to the holes exposed in Step 7.
  - c. Slide top forward to expose the front bottom top-to-pickup box attaching holes.
  - d. Attach the second brace to these holes.
7. With assistance, lift the top and move it rearward for removal.

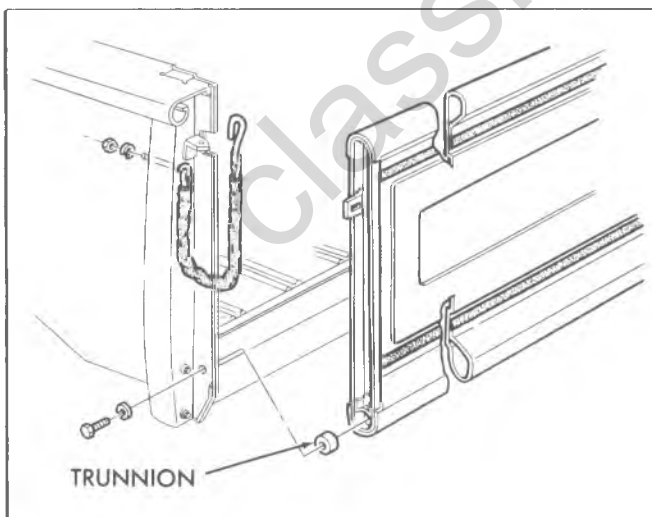

Fig. 70—Tailgate (03 and 63)

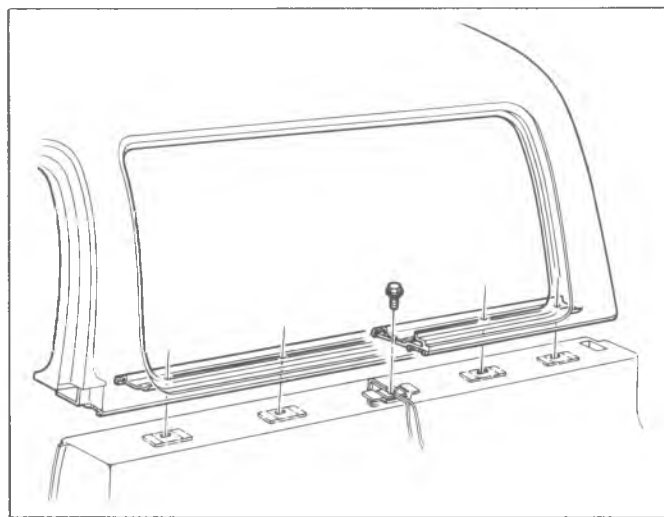

Fig. 72—Removable Top

## SEATS

### Care and Cleaning of Interior Soft Trim

Dust and loose dirt that accumulate on interior fabric trim should be removed frequently with a vacuum cleaner, whisk broom or soft brush. Vinyl or leather trim should be wiped clean with a damp cloth. Normal cleanable trim soilage, spots or stains can be cleaned with the proper use of trim cleaners available through General Motors dealers or other reputable supply outlets. Before attempting to remove spots or stains from upholstery, determine as accurately as possible the nature and age of the spot or stain. Some spots or stains can be removed satisfactorily with water or mild soap solution (refer to accompanying "Removal of Specific Stains"). For best results, spots or stains should be removed as soon as possible. Some types of stains or soilage such as lipsticks, some inks, certain types of grease, mustard, etc., are extremely difficult and, in some cases, impossible to completely remove. When cleaning this type of stain or soilage, care must be taken not to enlarge the soiled area. It is sometimes more desirable to have a small stain than an enlarged stain as a result of careless cleaning.

**CAUTION:** *When cleaning interior soft trim such as upholstery or carpeting, do not use volatile cleaning solvents such as: acetone, lacquer thinners, carbon tetrachloride, enamel reducers, nail polish removers; or such cleaning materials as laundry soaps, bleaches or reducing agents (except as noted in the instructions on stain removal). Never use gasoline or naphtha for any cleaning purpose. These materials may be toxic or flammable, or may cause damage to interior trim.*

### Cleaning Fabrics with Cleaning Fluid

This type of cleaner should be used for cleaning stains containing grease, oil or fats. Excess stain should be gently scraped off trim with a clean dull knife or scraper. Use very little cleaner, light pressure, and clean cloths (preferably cheese cloth). Cleaning action with cloth should be from outside of stain towards center and constantly changing to a clean section of cloth. When stain is cleaned from fabric, immediately wipe area briskly with a clean absorbent towel or cheese cloth to help dry area and prevent a cleaning ring. If ring forms, immediately clean entire area or panel section of the trim assembly.

**NOTE:** Sometimes a difficult spot may require a second application of cleaning fluid followed immediately by a soft brush to completely remove the spot.

### Cleaning Fabrics with Detergent Foam Cleaners

This type of cleaner is excellent for cleaning general soilage from fabrics and for cleaning a panel section where a minor cleaning ring may be left from spot

cleaning. Vacuum area to remove excess loose dirt. Always clean at least a full trim panel or section of trim. Mask adjacent trim along stitch or weld lines. Mix detergent type foam cleaners in strict accordance with directions on label of container. Use foam only on a clean sponge or soft bristle brush. Do not wet fabric excessively or rub harshly with brush. Wipe clean with a slightly damp absorbent towel or cloth. Immediately after cleaning fabric, dry fabric, with a dry towel or hair dryer. Rewipe fabric with dry absorbent towel or cloth to restore the luster of the trim and to eliminate any dried residue.

### Removal of Specific Stains

#### Candy

Chocolate, use cloth soaked in lukewarm water; other than chocolate, use very hot water. Dry. If necessary, clean lightly with fabric cleaning fluid.

#### Chewing Gum

Harden gum with ice cube and scrape off with dull knife. Moisten with fabric cleaning fluid and scrape again.

#### Fruit Stains, Coffee, Soft Drinks, Ice Cream and Milk

Wipe with cloth soaked in cold water. If necessary clean lightly with fabric cleaning fluid. Soap and water is not recommended as it might set the stain.

#### Catsup

Wipe with cloth soaked in cool water. If further cleaning is necessary, use a detergent foam cleaner.

#### Grease, Oil, Butter, Margarine and Crayon

Scrape off excess with dull knife. Use fabric cleaning fluid.

#### Paste or Wax Type Shoe Polish

Light application of fabric cleaning fluid.

#### Tar

Remove excess with dull knife, moisten with fabric cleaning fluid, scrape again, rub lightly with additional cleaner.

#### Blood

Wipe with clean cloth moistened with cold water. Use no soap.

#### Urine

Sponge stain with lukewarm soap suds from mild neutral soap and clean cloth, rinse with cloth soaked in cold water, saturate cloth with one part household ammonia water and 5 parts water, apply for 1 minute, rinse with clean, wet cloth.

#### Vomitus

Sponge with clean cloth dipped in clean, cold water. Wash lightly with lukewarm water and mild neutral soap. If odor persists, treat area with a water-baking soda solution (1 teaspoon baking soda to one cup of tepid water). Rub again with cloth and cold water. Finally, if necessary, clean lightly with fabric cleaning fluid.

## SEAT MOUNTING

Typical Seat Mounting provisions are shown in figures 73 through 81.

**CAUTION:** See **CAUTION** on page 1 of this section regarding fasteners used on seats and seat belts.

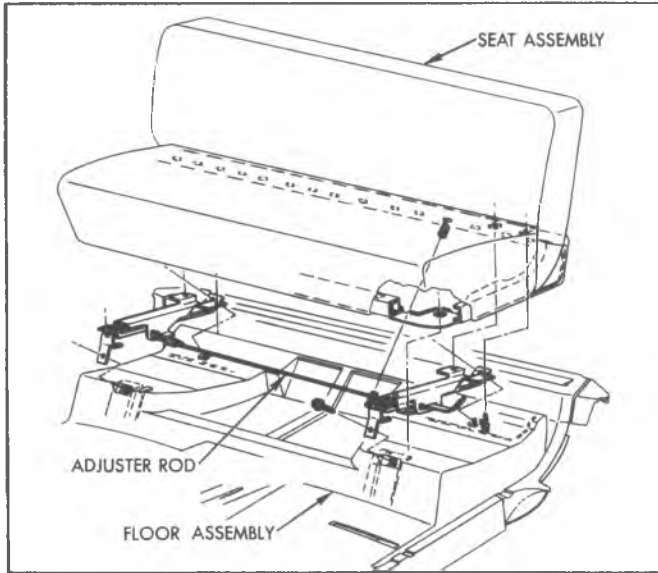

Fig. 73—Front Bench Seat (03, 06 and 63)

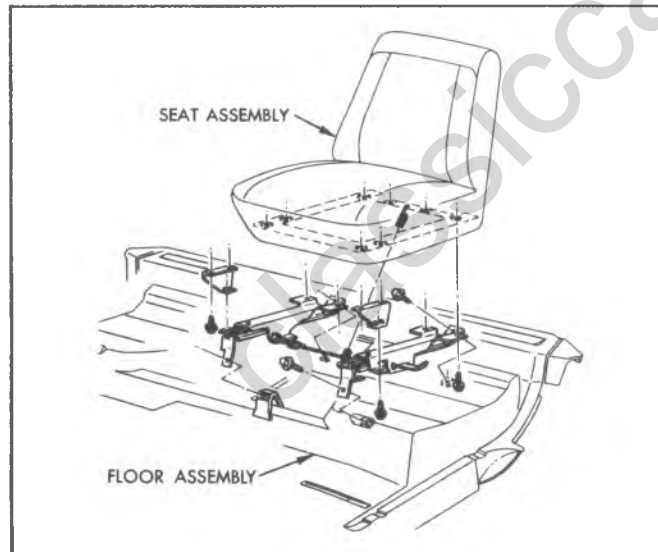

Fig. 74—Driver's Bucket Seat (03)

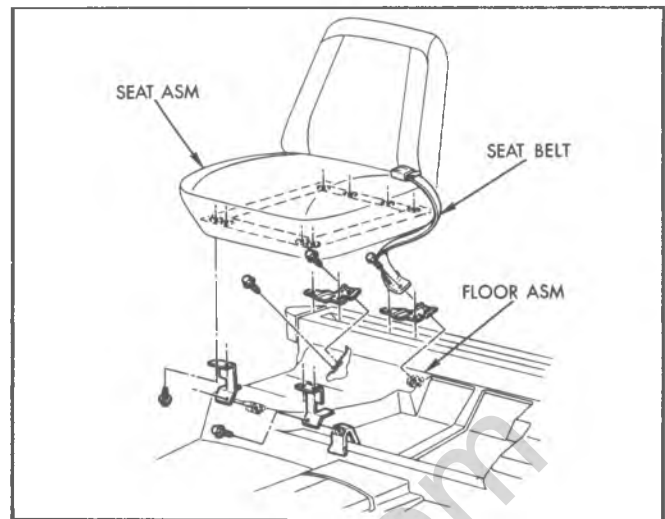

Fig. 75—Passenger's Bucket Seat (03)

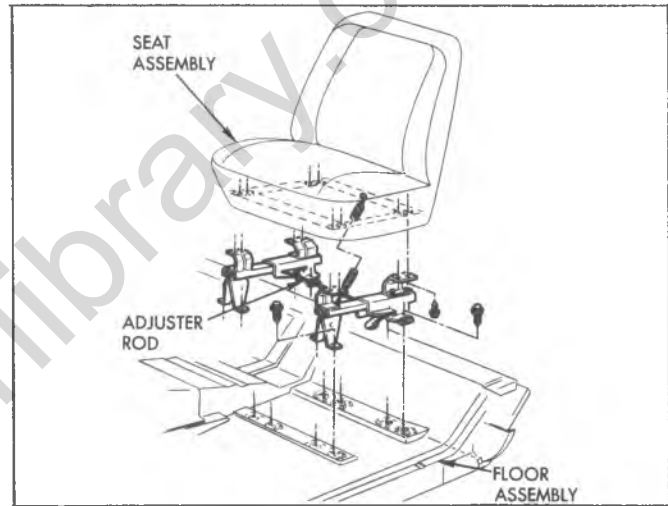

Fig. 76—Driver's Bucket Seat (14)

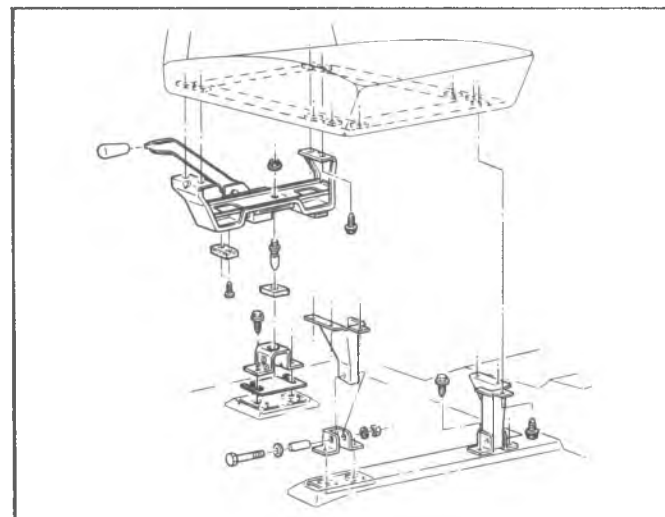

Fig. 77—Passenger's Bucket Seat (14)

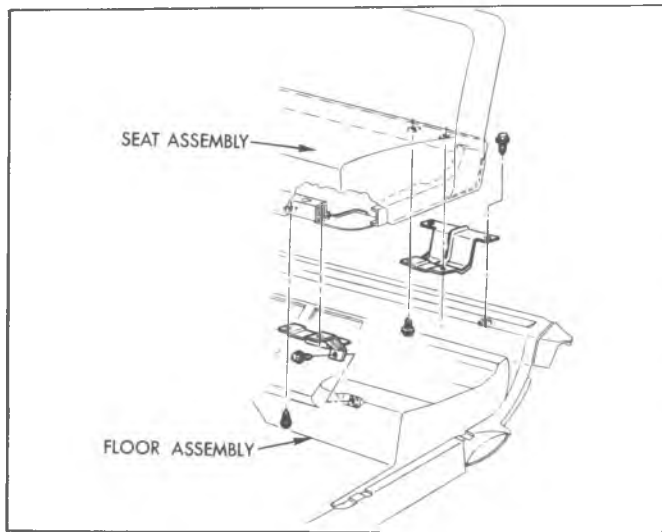

Fig. 78--Rear Bench Seat (63)

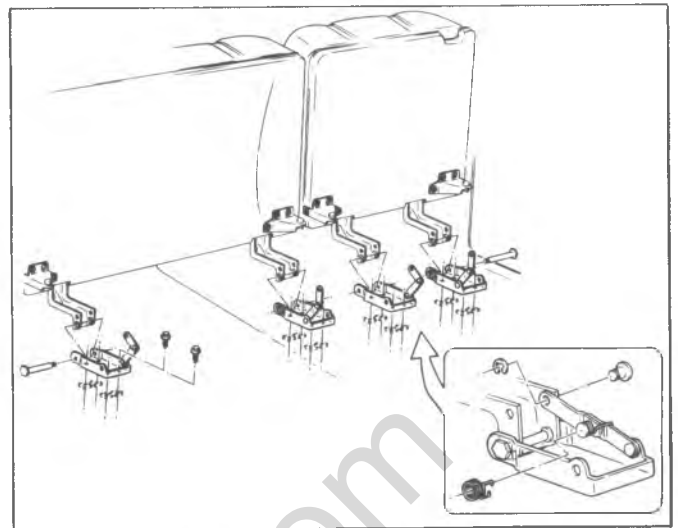

Fig. 80--Rear Folding Seat (06)

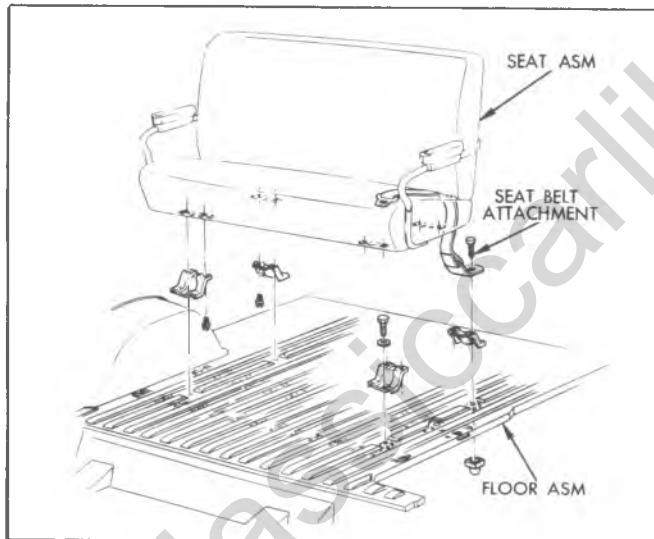

Fig. 79--Rear Bench Seat (06)

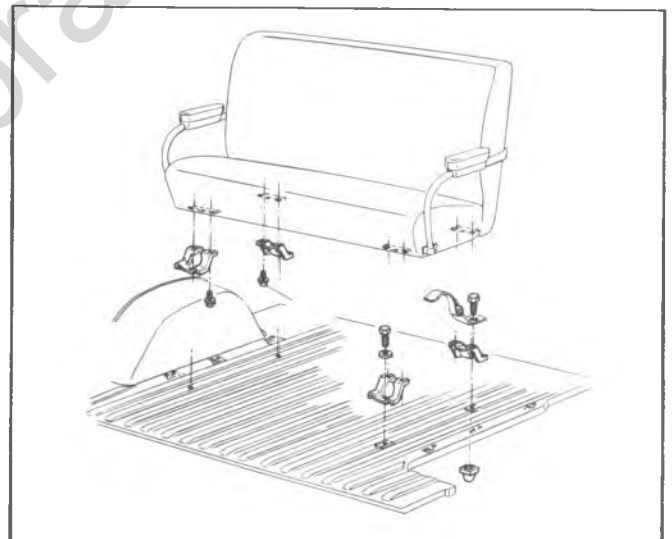

Fig. 81--Rear Bench Seat (14)

### BODY MOUNTING

The sequence of mounting attachments is shown in figures 82 through 85.

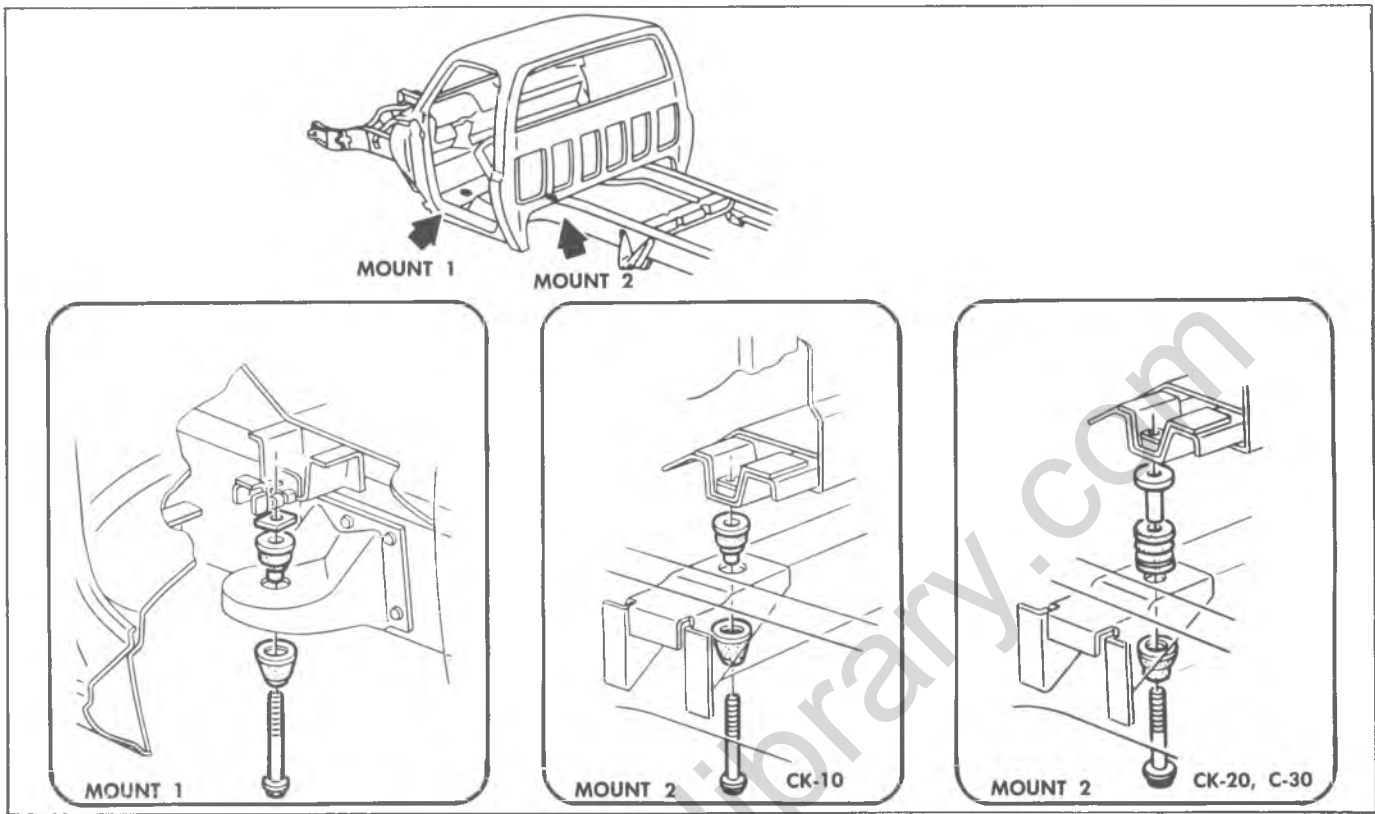

Fig. 82—Body Mounting (03)

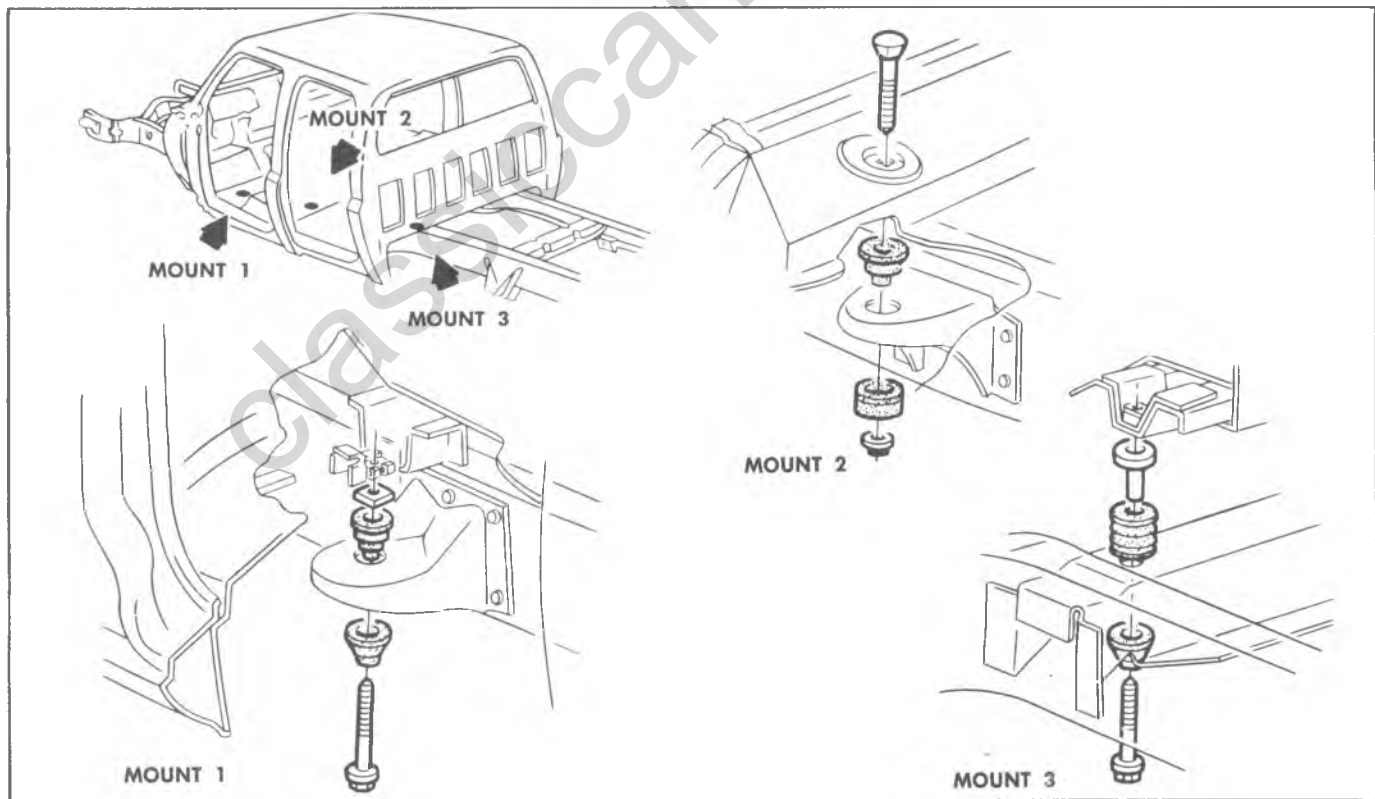

Fig. 83—Body Mounting (63)



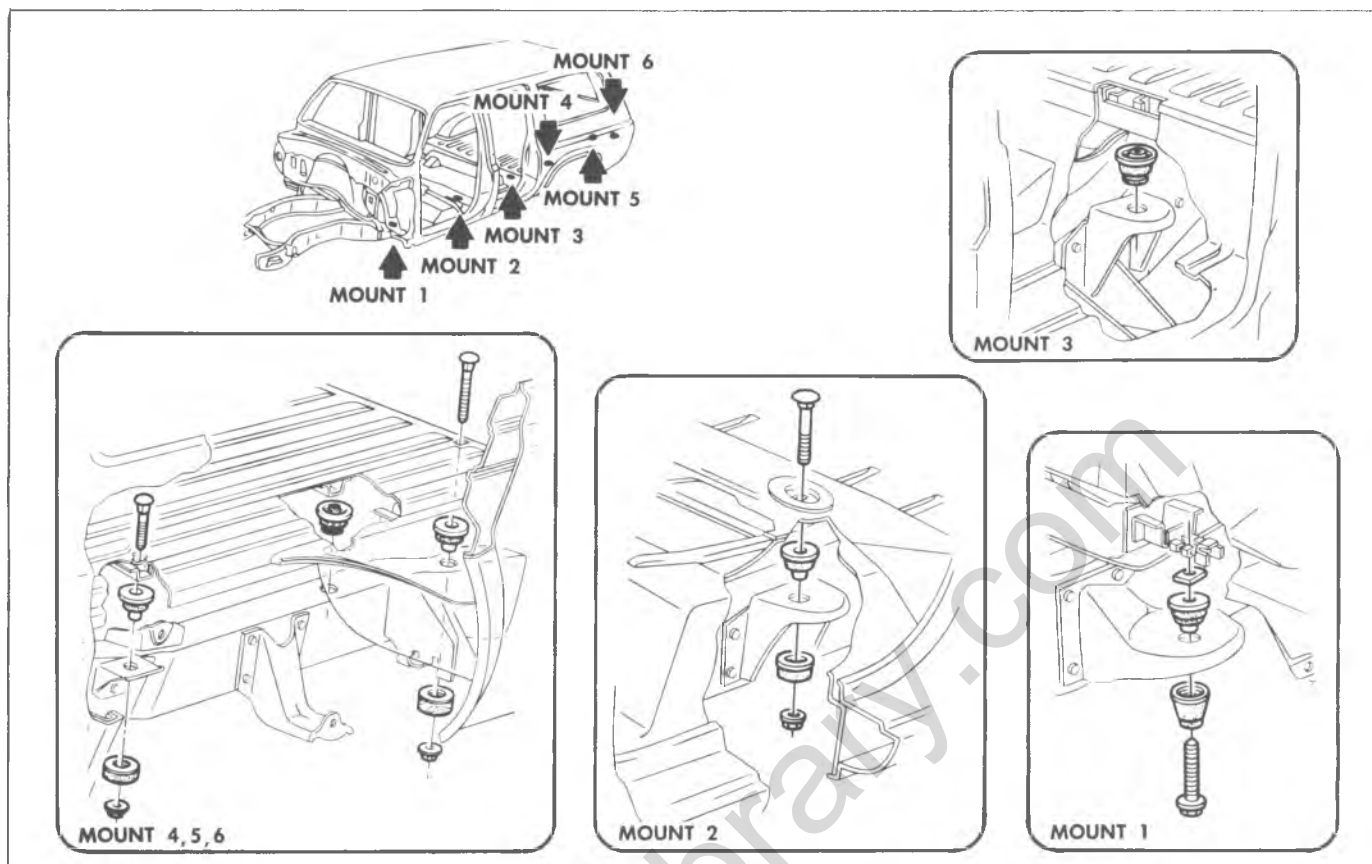

Fig. 84—Body Mounting (06)

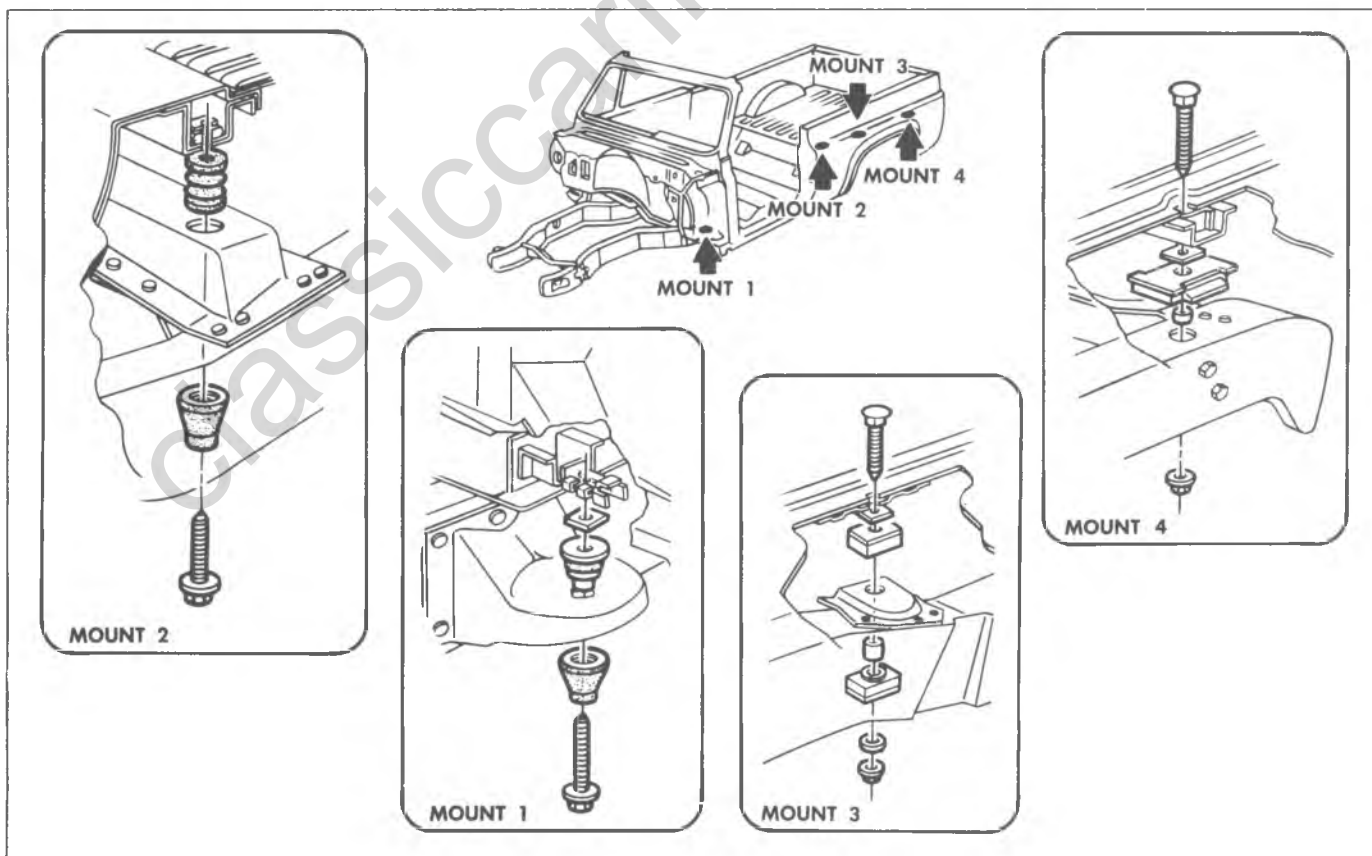

Fig. 85—Body Mounting (14)

## G MODELS

### INDEX

#### Front End

Windshield Wipers.....	1B-30
Cowl Ventilator Grille .....	1B-31
Side Ventilator Valve .....	1B-31
Rear View Mirror .....	1B-32

#### Body Glass

Windshield Glass.....	1B-32
Stationary Glass.....	1B-34
Swingout Glass.....	1B-34

#### Front Door

Adjustments.....	1B-34
Replacement.....	1B-34
Weatherstrip.....	1B-34
Hinges.....	1B-35
Ventilator .....	1B-36
Window and Regulator .....	1B-37
Locks, Handles, Rods .....	1B-37

#### Sliding Side Door

Adjustments.....	1B-38
Front Latch.....	1B-41
Rear Latch .....	1B-42
Upper Left Hinge.....	1B-42

#### Rear Door

Hinge .....	1B-44
Remote Control.....	1B-44
Latches and Rods .....	1B-44
Adjustments.....	1B-45

#### Seats

Drivers Seat.....	1B-46
Passenger Seat.....	1B-46
Rear Seats.....	1B-46

## FRONT END

### WINDSHIELD WIPERS

Windshield wiper units on all models are of the two-speed electric type. A single wiper motor unit, mounted to dash panel at top and to left of engine cover inside cab, powers both wiper blades. The wiper blade operating link rods and pivot mountings on these models are located in the outside air inlet plenum chamber.

#### Arm Adjustment

To adjust sweep of blades turn on wipers, then note sweep of arms. If necessary, remove one or both arms as follows: Pull outer end of arm away from glass which will trip lock spring at base of arm and release spring from undercut of pivot shaft. While holding arm in this position, pull outward on cap section at base of arm to remove arm. Arm can be reinstalled in any one of several positions due to serrations on pivot shaft and in arm cap. See figure 1G.

### WIPER ARM PIVOT SHAFTS AND LINK ROD—FIG. 2G

#### Removal

1. Remove windshield wiper arms from pivot shafts. Procedure for removing arms is explained previously under "Arm Adjustments."
2. Remove screws which attach outside air cowl ventilator grille to cowl. Carefully remove grille from cowl.
3. At center of cowl, remove two attaching nuts which

attach link rod to motor drive. Disengage link rods from pins.

4. Remove screws which attach each arm transmission pivot shaft assembly to cowl. Remove pivot shaft assembly with link rod from plenum chamber.

#### Installation

1. Place pivot shaft assembly with link rod into position at cowl bracket. Secure assembly to bracket with two screws.
2. Attach end of link rod to motor drive and arm. Secure rod with the two attaching nuts.

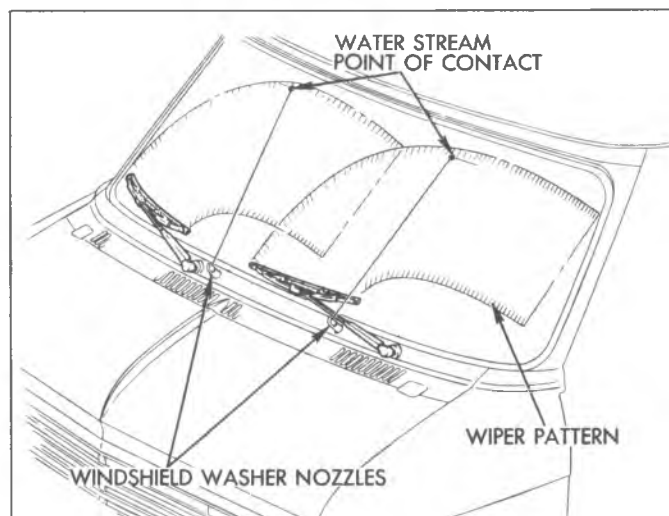

Fig. 1G—Wiper Pattern

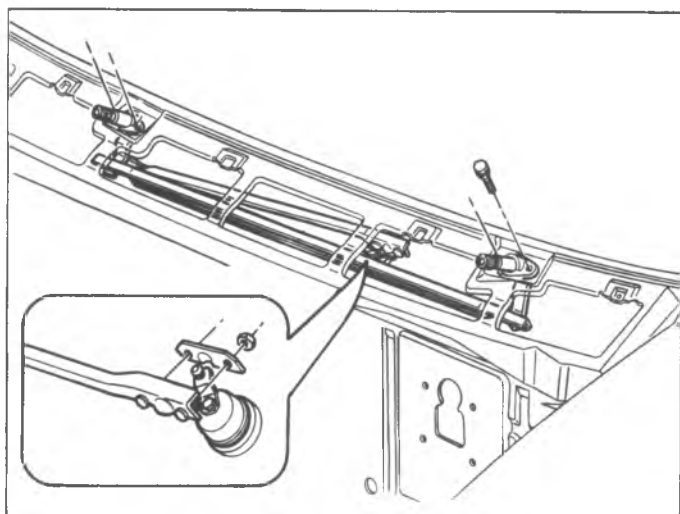

Fig. 2G—Windshield Wiper Linkage

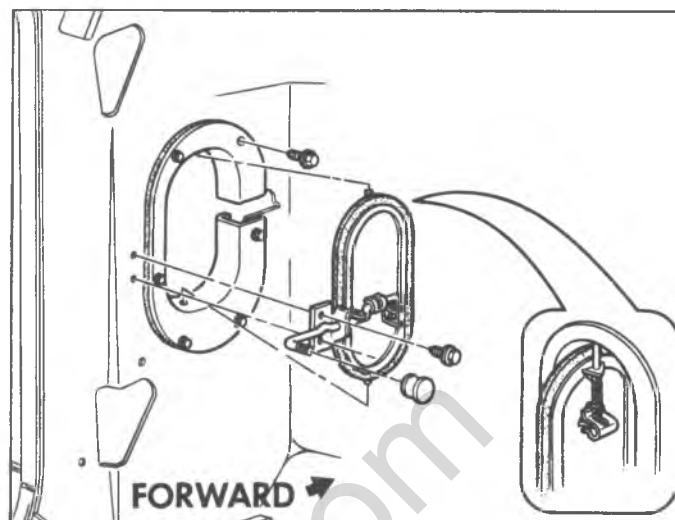

Fig. 4G—Side Cowl Ventilator

3. Install outside air cowl ventilator grille to top of cowl.
4. Before installing wiper arms, operate wiper motor momentarily which should rotate pivot shafts to park position. Install arms.

### COWL VENTILATOR GRILLE

#### Replacement

1. Remove windshield wiper blades.
2. Remove screws retaining grille, figure 3G.
3. Remove grille and seal.
4. Reverse above steps to install grille.

### COWL SIDE VENT VALVE

#### Replacement

1. Remove screws retaining valve guide to panel, as shown in figure 4G.
2. Remove valve assembly by depressing pins at top and bottom of valve.
3. Reverse the above steps for installation.

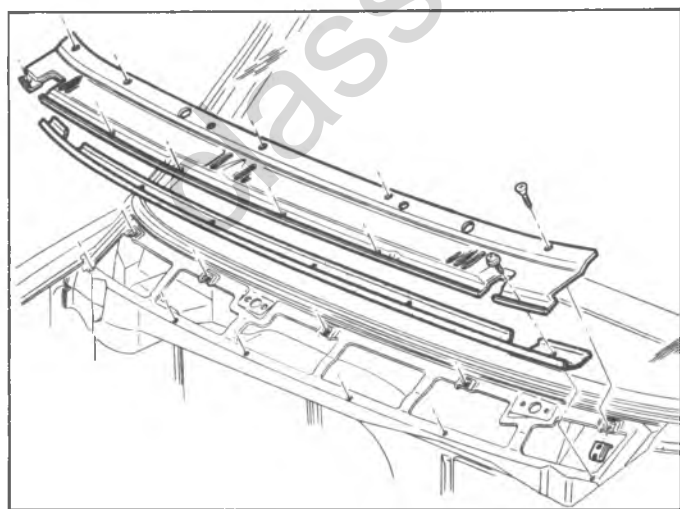

Fig. 3G—Cowl Ventilator Grille

## REAR VIEW MIRRORS

### Inside Rear View Mirror

#### Replacement

The inside mirror may be removed by removing screw retaining mirror to its glass-mounted bracket, and lifting mirror off bracket.

### Outside Rear View Mirrors

Outside rear view mirror installations are shown in figure 6G. Occasional tightening of mounting and assembly bolts and screws will sharply decrease occurrence of failure due to door slamming or road shock.

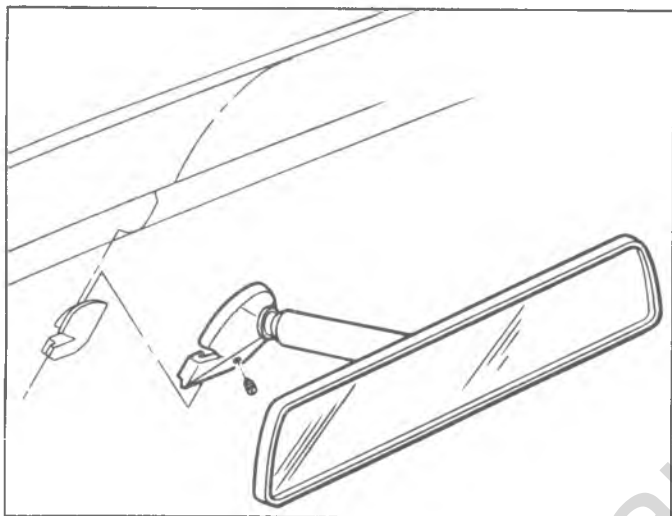

Fig. 5G—Inside Rear View Mirror

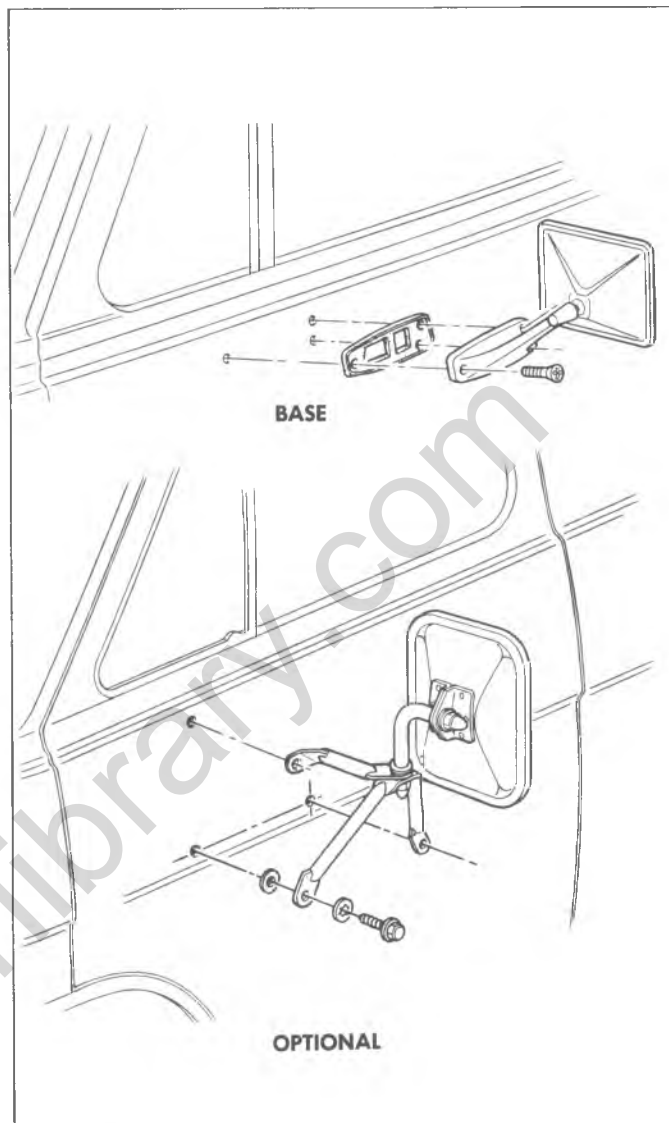

Fig. 6G—Outside Rear View Mirrors

## BODY GLASS

**WARNING:** Always wear gloves when handling glass.

### WINDSHIELD GLASS

The windshield is a one-piece type and is retained in the windshield opening by a moulded rubber weatherstrip. This weatherstrip is sealed in the windshield opening and sealed to the windshield glass. See figure 7G.

When replacing a cracked windshield glass, it is very important that the cause of the glass breakage be determined and the condition corrected before a new glass is installed. Otherwise, it is highly possible that a small obstruction or high spot somewhere around the windshield opening will continue to crack or break the

newly installed windshield, especially when the strain on the glass caused by this obstruction is increased by such conditions as wind pressures, extremes of temperature, motion of the vehicle, etc.

The procedure for removal of the windshield applies to the complete windshield assembly and to other stationary glass, such as in figure 10G.

#### Removal

**NOTE:** Refer to figures 14-16 in the "C-K Models" portion of this section for illustration of removal technique.

1. Before removing the windshield, mark the location of the break on the windshield rubber channel and the body. Protect the paint finish inside of the cab.



Fig. 7G—Windshield Glass

Mask around the windshield opening and outside, lay a suitable covering across the hood and fenders.

NOTE: The windshield glass rubber weatherstrip is one piece. The glass is held in a channel within the weatherstrip.

2. Do not try to remove reveal moldings while windshield is in body opening. Remove reveal molding from custom weatherstrip retention groove after windshield is removed from body opening.
3. To free windshield rubber channel of weatherstrip loosen the lip of the windshield weatherstrip from the pinchweld flange along the top and at the sides by applying firm, controlled pressure to the edge of the glass. At the same time assist the lip of the rubber weatherstrip channel over the pinchweld flange with a flat bladed tool.

#### Checking Windshield Opening

Due to the expanse and contour of the windshield it is imperative in the event of a stress crack that the windshield opening be thoroughly checked before installing a replacement windshield. The replacement glass is used as a template.

1. Check for the following conditions at the previously marked point of fracture.
  - a. Chipped edges on glass.
  - b. Irregularities in body opening.
  - c. Irregularities in rubber channel weatherstrip.
2. Remove all sealer from flange and body around windshield opening.

3. Check flange area for solder, weld high spots, or hardened spot-weld sealer. Remove all high spots.
4. Check windshield glass to opening, by supporting glass with six spacers contained in packet J-22577, as shown in figure 8G.

**CAUTION:** Do not strike glass against body metal. Chipped edges on the glass can lead to future breaks.

NOTE: It is necessary to modify the spacers by cutting off 3/16" from the back of the spacer with a knife, as shown in figure 8G.

5. With the windshield supported and centered in its opening, check the relationship of the glass to the body opening flange around the entire perimeter of the glass.
6. Check the relationship of glass to opening as follows:
  - a. Inside edge of glass to body flange.
  - b. Outer edge of glass to parallel body metal.
7. Mark areas of body metal or flange to be reformed, remove glass and correct as necessary.
8. Recheck windshield in its opening and if satisfactory proceed as follows:

#### Installation

1. Apply sealer to weatherstrip and install on glass.
2. Install a cord around periphery of weatherstrip, leaving a loop at the top and the loose ends at the bottom. See figure 9G.
3. Place protective covering over plenum grille, front fenders and hood.
4. Place windshield and weatherstrip assembly in opening. With one technician lightly pushing in on windshield, another technician within the cab should pull on the cord as follows:

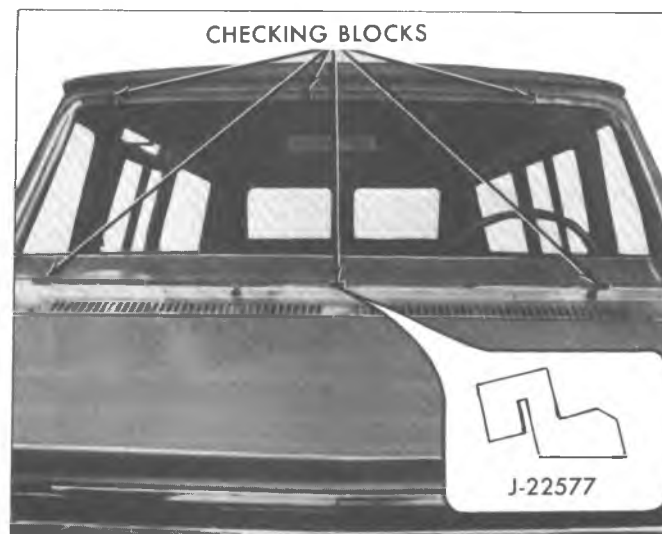

Fig. 8G—Checking Windshield Opening

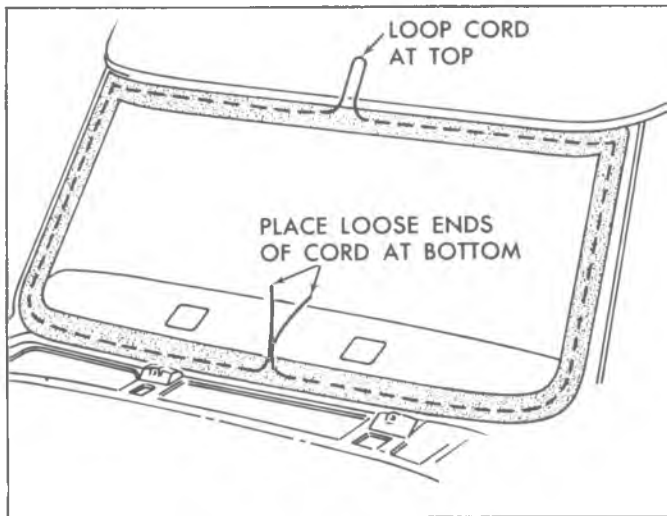

Fig. 9G—Cord Installation

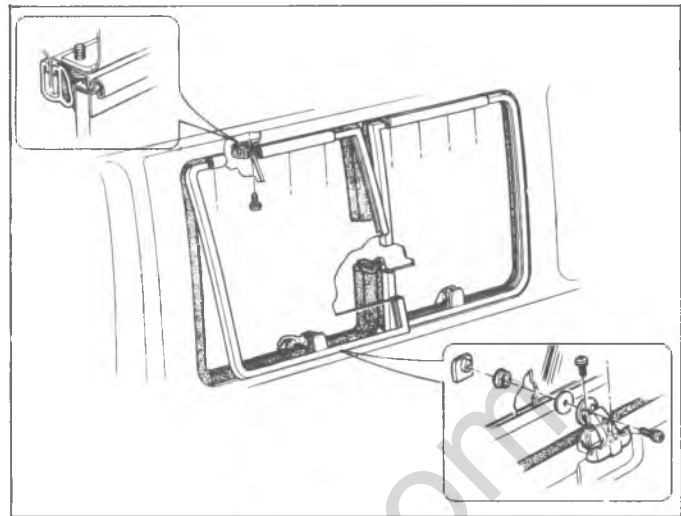

Fig. 11G—Swingout Window

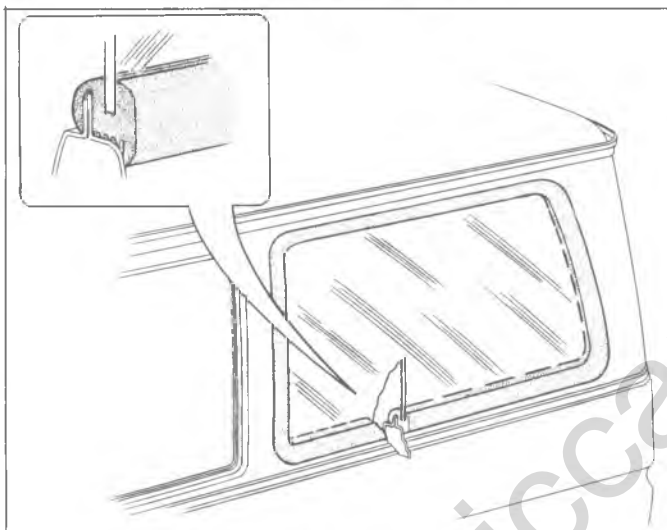

Fig. 10G—Body Window Glass

- Pull on loose ends until each is within 2" of its respective upper corner.
- Pull on loop until cord is within 2" of the upper corners.
- Finish seating corners by simultaneously pulling on both ends of the cord at each corner. This will insure proper positioning of the critical upper corners.

- Seal windshield to weatherstrip and weatherstrip to body.

## SWINGOUT WINDOW

### Removal

- Swing out the window. See figure 11G.
- Remove screws retaining latch to body.
- Remove window hinge retaining screws and window.
- Remove latch from glass.

### Installation

- Install latch to glass using escutcheon, spacer, washer, latch and screw. Torque to specifications.
- Place window into opening and install hinge retaining screws and window.
- Install latch to glass.

## LATCH SWINGOUT WINDOW

### Replacement

- Swing out the window.
- Remove latch to body and latch to window screws and remove latch.
- Reverse above steps for installation.

## FRONT DOOR

### DOOR ADJUSTMENTS

Doors can be adjusted for alignment of clearance in the cab door opening, and for proper latching. Door alignment adjustments are made at the striker bolt, and at door hinges. The door, when properly located in door opening, will have equal clearance around its perimeter.

The door should be adjusted in the opening so the edge of the door across the top and also at the lock side is parallel with the body opening as nearly as possible.

### Hinge Adjustment

Door hinge bolt holes are oversized to make adjustment

possible. Alignment adjustments can be made by loosening the proper hinge bolts, aligning door to proper position, and tightening bolts securely. See figure 12G, for typical adjustments.

### Striker Bolt Adjustment

With the use of J-23457, shown in figure 13G, the striker bolt can be adjusted in any of three ways. See figure 14G.

1. **Up and down**—To adjust striker up or down, loosen bolt, adjust to center of lock entry, and tighten bolt securely.

NOTE: This adjustment is important to assure that the right proportion of door's weight will rest on striker bolt when door is closed. If bolt is positioned too high on pillar, rapid wear will occur to the lock cam; if too low, an extra load will be placed on door hinges as well as pull door downward and out of alignment.

2. **In and Out**—To adjust striker in and out, loosen bolt, adjust horizontally to match the door surface to the body surface, and tighten bolt securely.
3. **Forward and Rearward**—To make this adjustment, loosen striker bolt, shim to desired position, and tighten bolt securely.

### DOOR HINGE

#### Remove

1. Remove hinge access hole cover from door hinge pillar.
2. If removing one hinge, support door in such a manner that weight is taken off other hinge, and that the door will not move.
3. Remove hinge screws from both body and from door and remove hinge. See figure 12G.

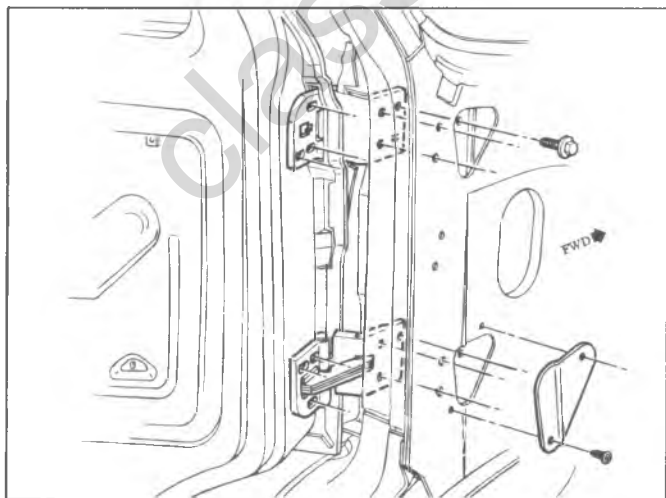

Fig. 12G—Door Hinge



Fig. 13G—Loosening Striker Bolt

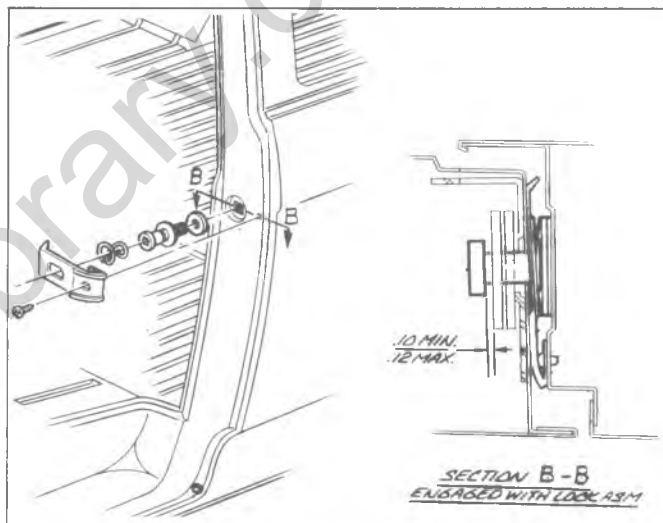

Fig. 14G—Typical Striker Bolt Adjustment

#### Installation

1. Install hinge to door and body. Snug bolts.
2. Remove door supports.
3. Adjust door as outlined under "Door Adjustment".
4. Torque bolts to specifications.
5. Install hinge access hole covers.

### DOOR WEATHERSTRIP

Success of weatherstrip replacement depends entirely upon the quality of the cement used and the care with which it is applied. All rust, road dirt and grease or oil must be completely removed as should all old cement and bits of old weatherstrip. After removing all foreign material from door opening surface, wipe down with prepsol or its equivalent. Use only a good quality cement which is made specially for weatherstrip installation, following the manufacturer's directions. Proceed as follows:

## 1B-36 BODY

1. Open door and block open.
2. Remove side door weatherstrip.
3. Remove used adhesive from door with adhesive or cement remover, and remove all plastic nails.
4. Apply adhesive to door.
5. Position weatherstrip by locating part number at top of vent window, making sure that plastic nails align with holes in door.
6. Install weatherstrip by pressing each nail into the door.

## TRIM PANEL, ARM REST AND HANDLES

### Removal

1. Remove screws retaining arm rest to trim panel.
2. Remove door handles with Tool J-7797 and pull from shaft.
3. Remove trim panel screws and remove panel. If seal is damaged, replace seal.

### Installation

1. Install trim panel.
2. Install arm rest. Install door handle washers and handles.

## DOOR VENTILATOR ASSEMBLY

### Removal

NOTE: The channel between the door window glass and door vent is removed as part of the vent assembly.

1. Regulate the door window glass to the full down position.
2. Remove door handles with Tool J-7797.
3. Remove trim panel.
4. Remove rear window run channel screws.
5. Slide door window glass rearward away from ventilator.
6. Remove three screws at the upper front of the door, as shown in figure 15G.
7. Turn the vent assembly 90° and carefully remove by guiding up and out, as shown in figure 16G.

### Ventilator Glass Replacement

1. Using an oil can or similar means, squirt prepsol on the glass filler all around the glass channel or frame to soften the old seal. When the seal has softened, remove the glass from the channel.
2. Thoroughly clean the inside of the glass channel with sandpaper, removing all rust, etc.
3. Using new glass channel filler, cut the piece to be installed two inches longer than necessary for the channel. Place this piece of filler (soapstoned side of filler away from glass) evenly over the edge of the glass which will fit in the channel. The extra filler extending beyond the rear edge of the glass

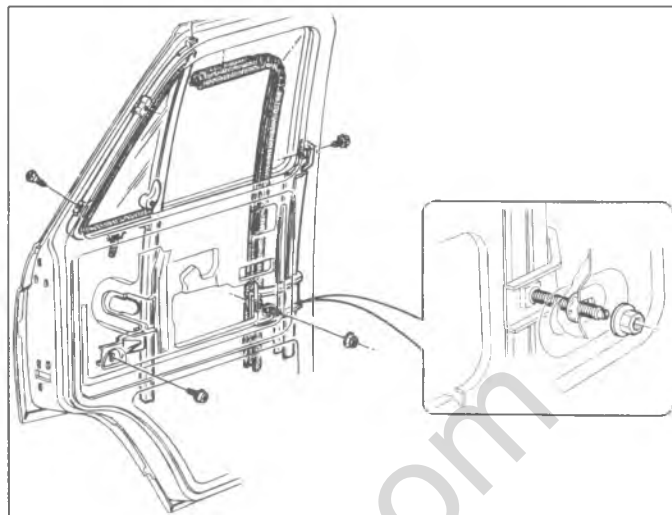

Fig. 15G—Ventilator Assembly

should be pinched together to hold it in place during glass installation.

NOTE: One side of this filler (the outside of the roll) is soapstoned. This is the side which goes into the metal channel.

4. Brush the inside of the metal glass channel freely with ordinary engine oil. This will enable the glass and filler to slide freely into the channel.

NOTE: Glass should be installed so that rear edge is parallel to the division post. Allow full cure before water testing.

### Installation

NOTE: Replace the door window glass and regulate to the full down position before installing the door ventilator assembly.

1. Lower the ventilator assembly into the door frame. Center into position.



Fig. 16G—Removing Ventilator



2. Make certain the rubber lip is positioned before tightening screws.
3. Slide door glass forward engaging glass in vent channel.
4. Reinstall all screws and tighten.
5. Install and tighten the three screws at the upper front of the door.

**Adjustment**

1. Adjust the ventilator adjusting nut by turning clockwise to increase operating tension, as shown in figure 17G.
2. After making adjustment bend tabs over the hex nut.
3. Install trim panel.
4. Install door and window regulator handles.

**DOOR WINDOW ASSEMBLY**

**Replacement**

1. Completely lower glass to bottom of door.
2. Remove inside door and window regulator handles using Tool J-7797.
3. Remove door arm rest and trim pad.
4. Mask or cover upper portion of door window frame. Remove ventilator assembly as previously outlined.
5. Slide glass forward until front roller is in line with notch in sash channel. Disengage roller from channel. See figure 18G.
6. Push window forward and tilt front portion of window up until rear roller is disengaged.
7. Put window assembly in normal position (level) and raise straight up and out.
8. Reverse above procedure for installation.



Fig. 17G—Adjusting Ventilator Tension

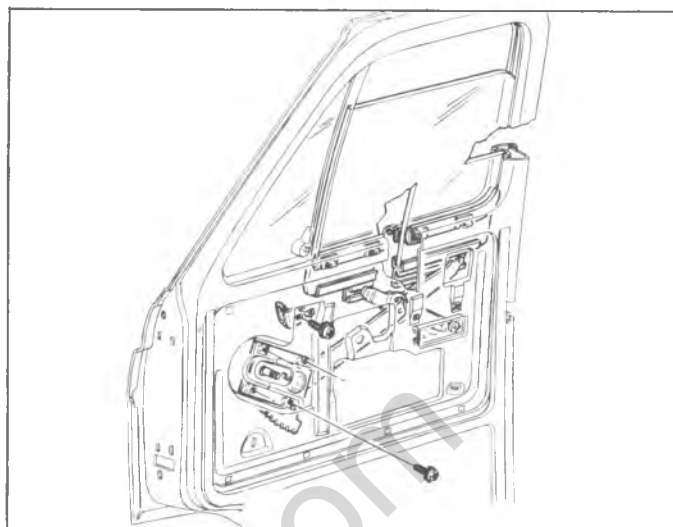

Fig. 18G—Window and Regulator

**WINDOW REGULATOR**

**Replacement**

1. Wind window all the way up.
2. Remove inside door handles with Tool J-7797.
3. Remove door trim pad.
4. Remove screws securing regulator to inner panel.
5. Push regulator out of door opening while holding rear of assembly, then slide assembly to the notches in the carrier channel and out through the door access hole.
6. Install regulator in reverse order of removal, lubricate regulator gears with lubriplate or equivalent.

**DOOR LOCK—FIGURE 19G**

**Removal**

1. Raise window.
2. Remove inside handles with Tool J-7797.
3. Remove trim panel.
4. Remove remote control sill knob.
5. From outside the door remove screws retaining lock to door edge and lower the lock assembly.
6. Remove screws retaining remote control.
7. Remove screws securing glass run guide channel.
8. Remove lock, push button rod and remote control rod as an assembly.

**Installation**

1. Transfer remote rod with clip to new lock.
2. Connect remote door handle rod to lock after lock is positioned.
3. Secure lock screws.
4. Secure remote handle.

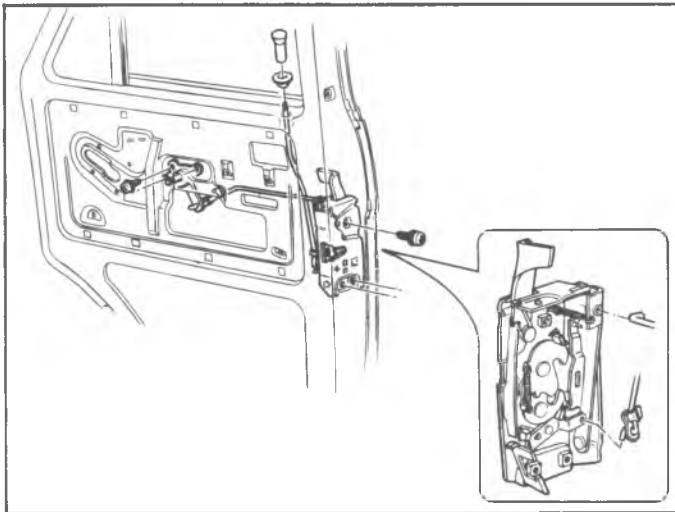

Fig. 19G—Lock and Remote Control Assembly

5. Check all controls for proper operation before reinstalling trim and handles.
6. Install remote control sill knob.

### REMOTE CONTROL AND CONNECTING ROD—FIG. 19G

#### Replacement

1. Raise door window and remove door trim pad.
2. Remove bolts securing remote control to door inner panel.
3. Pivot remote inboard slightly, to disengage connecting rod, and remove remote control from door.

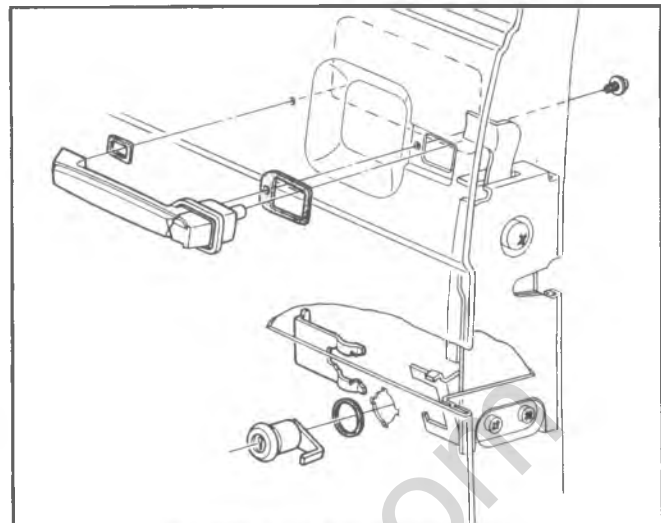

Fig. 20G—Lock Cylinder Assembly

NOTE: Connecting rod can be removed at this point by disconnecting spring clip from lock.

4. To install, reverse removal procedure.

### LOCK CYLINDER ASSEMBLY—FIG. 20G

#### Replacement

1. Raise door window and remove door trim pad.
2. With a screwdriver, or other suitable tool, slide lock cylinder retaining clip (on door outer panel) out of engagement and remove lock cylinder.
3. To install, reverse removal procedure.

## SLIDING SIDE DOOR

### DESCRIPTION

The weight of the sliding side door is supported by the upper rear hinge-and-roller assembly, and by the lower front catch-and-roller assembly. The front and rear latches retain the door in the locked position, while the rear wedge assembly restricts door vibration on rough road surfaces.

### ADJUSTMENTS

**CAUTION:** See *CAUTION* on page 1 of this section regarding all sliding door fasteners and adjustments found below.

The side door can be adjusted for alignment and/or clearance in the body opening and for proper latching. When properly positioned in the body opening, the door

should have equal clearances around its perimeter. Adjustments for door positioning and proper latching can be made at the locations shown in figure 21G.

### Up and Down

Up and down adjustments are provided by means of slotted holes located at the upper front roller, view B of figure 21G; at the lower front catch-and-roller, view D; and at the upper rear hinge-and-roller assembly, view A. To reposition the door up or down:

1. Partially open door and loosen front latch striker on pillar.
2. Remove upper rear hinge cover, shown in figure 22G.
3. Loosen upper rear hinge-to-door bolts.

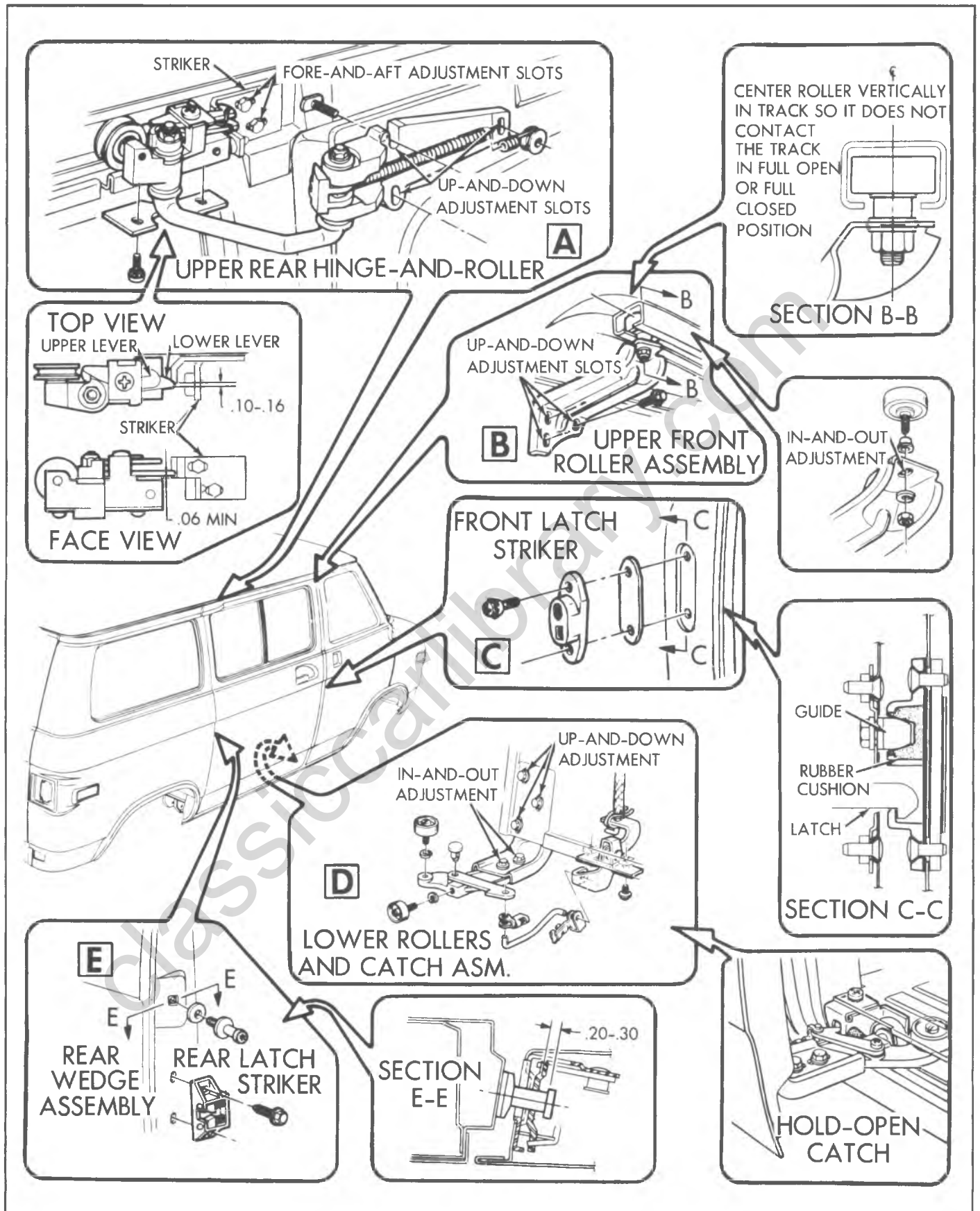

Fig. 21G—Sliding Side Door Adjustment Locations

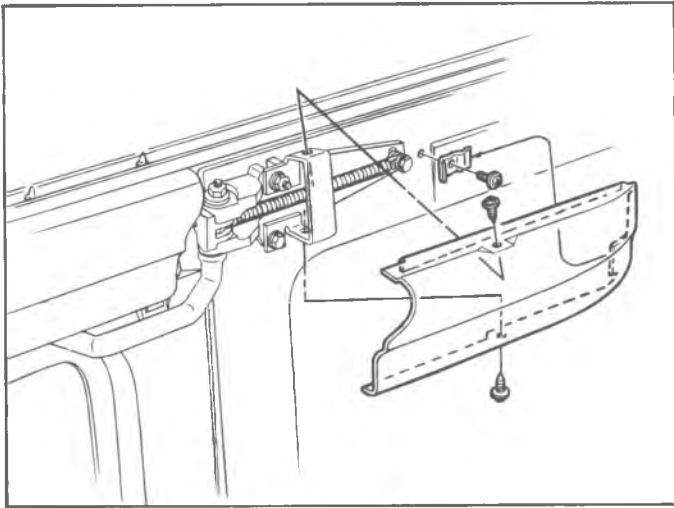

Fig. 22G—Hinge Cover

4. Loosen rear lock striker and door wedge assembly.
5. Align rear edge of door up or down, then tighten upper rear hinge-to-door bolts to specifications.
6. Loosen upper front roller bracket-to-door bolts.
7. Partially close door and align front edge of door up or down by loosening front lower hinge-to-door bolts. When door is correctly positioned, tighten bolts to specifications.
8. Position upper front roller in center of track, then tighten roller bracket to door.
9. Adjust front and rear strikers and rear wedge assembly as outlined in their respective procedures later in this section.

### In and Out

Front in and out adjustments are provided by means of an adjustable lower roller mounting bracket, view D of figure 21G, and by a slotted upper bracket, view B of figure 21G. Rear in and out adjustment is provided by adjusting the rear latch striker, view E of figure 21G. To position the door in or out:

1. Loosen front latch striker.
2. Loosen upper front roller from its bracket.
3. Loosen lower front roller bracket-to-arm bolts.
4. Adjust front of door in or out, then tighten bolts to specifications.
5. Adjust door hold open catch bracket, rear wedge assembly, rear latch striker, upper front roller and front latch striker as outlined later in "Adjustments".

### Fore and Aft

Fore and aft adjustment is provided at the upper rear hinge striker by means of a slotted bracket mounted to the body, view A of figure 21G.

1. Partially open door and remove front latch striker and rear lock striker.

2. Loosen rear wedge assembly.
3. Remove upper rear track cover.
4. Loosen upper rear hinge striker.
5. Move door assembly forward or rearward, then tighten striker bolts to specifications.
6. Reinstall upper rear track cover.
7. Reinstall front and rear latch strikers.
8. Adjust latch strikers and rear wedge assembly as outlined below.

## Latch Striker Adjustments

### Front Striker

1. Loosen front latch striker screws, view C of figure 21G.
2. Visually align latch-to-striker relationship and adjust if necessary.
3. Slide door slowly toward striker. The guide on the door, just above the latch, must fit snugly within the rubber-lined opening on the striker assembly.
4. Assure that the latch engages fully into the striker. Add or delete shims behind the striker as necessary.
5. Tighten striker screws to specified torque.

### Rear Striker

1. Loosen striker with J-23457.
2. Loosen rear wedge assembly.
3. Center the striker vertically to door striker opening.
4. Adjust the striker laterally to match outer panel to the body panel surfaces, view E of figure 21G.
5. Apply grease to the striker.
6. Gently push the door in until the rear lock contacts the striker enough to make an impression in the grease.
7. Open the door and measure the distance from the rear of the striker head to the impression. The distance should be between .20 inch and .30 inch. Refer to view E of figure 21G.
8. Adjust position of striker by adding or deleting shims between the striker and the pillar.
9. Adjust rear wedge assembly as outlined later in this section, and torque all fasteners to specifications.

### Upper Rear Hinge-to-Striker Adjustment

**CAUTION:** If door has been removed and is being reinstalled, adjust striker-to-lower hinge lever before closing door. Failure to do so may cause possible lever breakage.

The upper rear hinge must be positioned as shown in view A of figure 21G, in order to insure proper latching.

1. The hinge lower lever must contact the striker at least .06 inch above the lower edge of the striker tang.



Fig. 23G—Hold-Open Catch

2. The lower lever must extend at least .10 inch outboard of the striker tang. Add or delete shims between the striker and the body as necessary.
3. If necessary to shim roller away from guide, shims are added between the nylon block and hinge and between roller and hinge. They must be installed in pairs. For example, if one shim is added behind the nylon block another must be added behind the roller.

### Door Hold-Open Catch Adjustment

This catch, mounted on the lower front roller bracket, holds the door in the full open position. See figure 23G. The catch engages a striker installed at the rear of the lower roller channel, view D of figure 21G.

1. Loosen the screws retaining the catch rod bracket to bottom of door.
2. Adjust catch-to-striker engagement by sliding the bracket laterally. Catch should fully engage striker.

### Rear Wedge Assembly Adjustment

1. Loosen screws attaching rear wedge assembly to the body pillar, then close the door to the fully latched position.
2. Center the wedge assembly on the door wedge, as shown in figure 24G, and scribe a line around the wedge assembly.
3. Open the door, and move the wedge assembly 3/16 inch outboard, and tighten screws to specifications.
4. Close the door and check the alignment. Both wedges should be depressed approximately 3/16 inch.

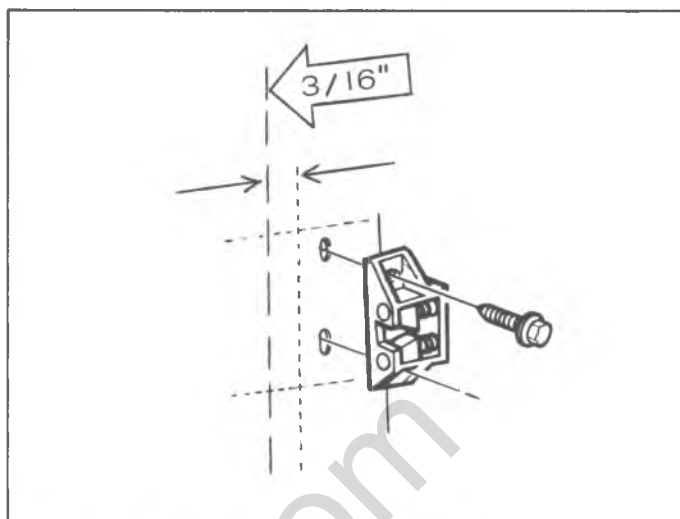

Fig. 24G—Adjusting the Rear Wedge Assembly

## COMPONENT PARTS REPLACEMENT

### FRONT LATCH ASSEMBLY

#### Removal

1. Remove trim panel, if so equipped.
2. Remove access cover.
3. Unscrew door lock knob from rod.
4. Disconnect the following rods from latch, shown in figure 25G.
  - a. Rear latch rods.
  - b. Lock cylinder rod.
  - c. Door lock rod.
5. Remove door handle.
6. Remove screws retaining latch assembly to door.
7. Slide latch rearward and lift front of latch. Disconnect rod leading to lower hinge door catch by pushing rod out of hole and rotating rod clear of latch. See figure 26G.
8. Remove latch assembly from door.

#### Installation

1. Install latch assembly into door by working latch assembly behind the lower hinge door catch.
2. Connect lower hinge door catch, lock cylinder rod, door lock rod, and both rear latch rods.
3. Install latch assembly-to-door attaching screws. Torque to specifications.
4. Install door lock knob and door handle.
5. Install access cover and trim panel.
6. Adjust door front striker as outlined earlier under "Adjustments".

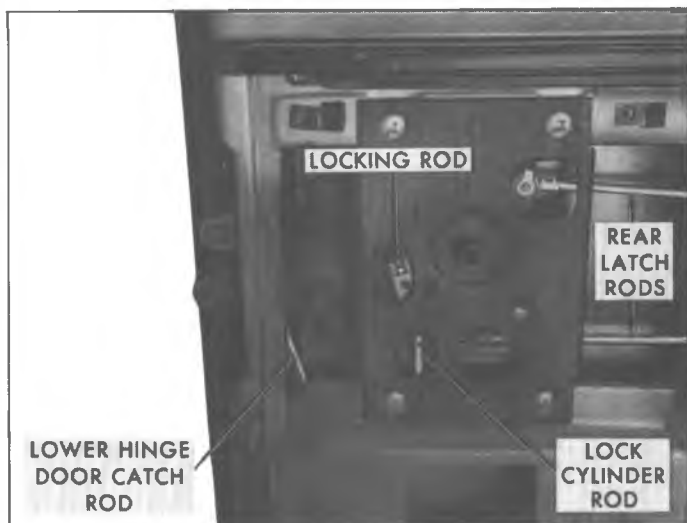

Fig. 25G—Sliding Door Front Latch

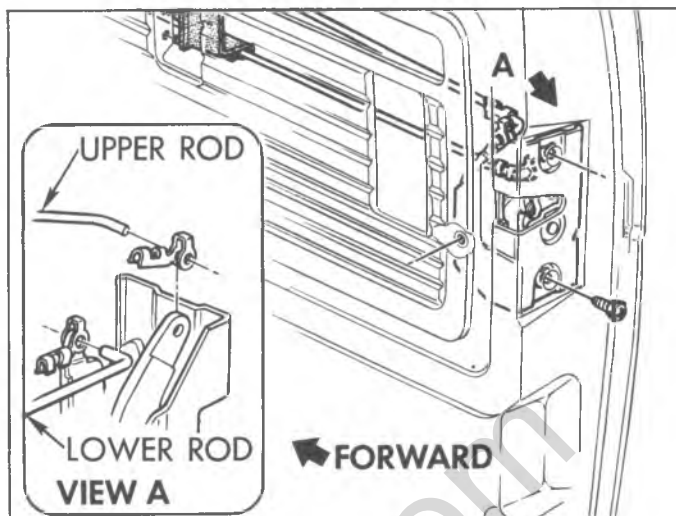

Fig. 27G—Sliding Door Rear Latch

## REAR LATCH AND/OR LATCH ACTUATING RODS

### Removal

1. Remove trim panel (if so equipped).
2. Remove front latch assembly access cover.
3. Disconnect rear latch rods from front latch assembly, shown in figure 25G.
4. Remove rear latch attaching screws. See figure 27G.
5. Slide rear latch toward front of door until rod clips become exposed. Disconnect rod clips and remove latch from door.

### Installation

1. Connect rods to latch and install latch to door. Torque screws to specifications.
2. Connect rods to front latch assembly.



Fig. 26G—Disconnecting Lower Latch Rod from Latch

3. Install access covers and trim panels (if so equipped).
4. Adjust rear latch striker as outlined earlier under "Adjustments".

## UPPER REAR HINGE

### Removal

1. Remove the hinge cover and rear track cover. See figures 22G and 28G.
2. Open the door.
3. Disengage spring from bolt, using a spring removal tool.
4. Close the door.
5. Remove the hinge assembly.

### Installation

NOTE: When holding hinge assembly as in figure 30G, the lower latch must engage cam.

1. Install hinge assembly to door. Torque bolts to specifications.
2. Check and adjust latch to striker position as outlined under "Adjustments".
3. Open the door and reconnect the hinge spring.
4. Install the rear track cover and hinge cover.
5. Check the operation of the door hinge.

## STRIKERS

The front and rear strikers are shown in figure 21G. The rear striker can be removed with J-23457 as in figure 13G, and the front striker can be removed by removing attaching screws. Refer to "Adjustments" when reinstalling.

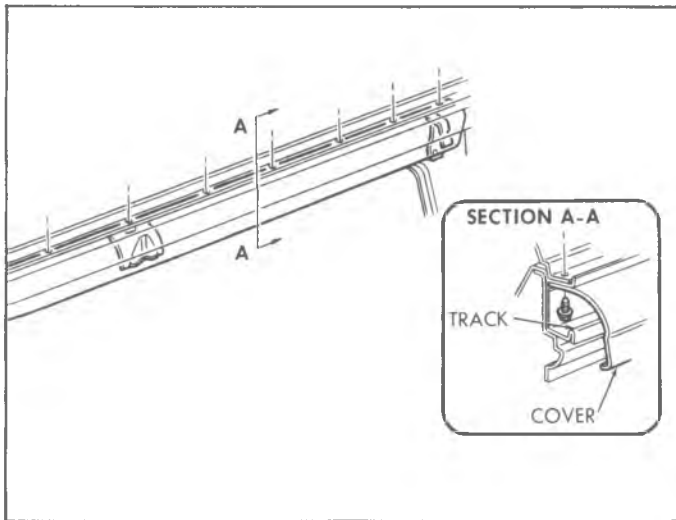

Fig. 28G—Rear Track Cover

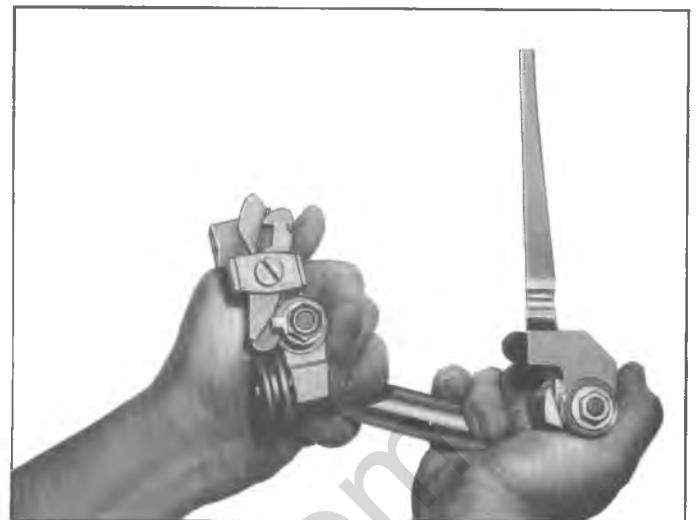
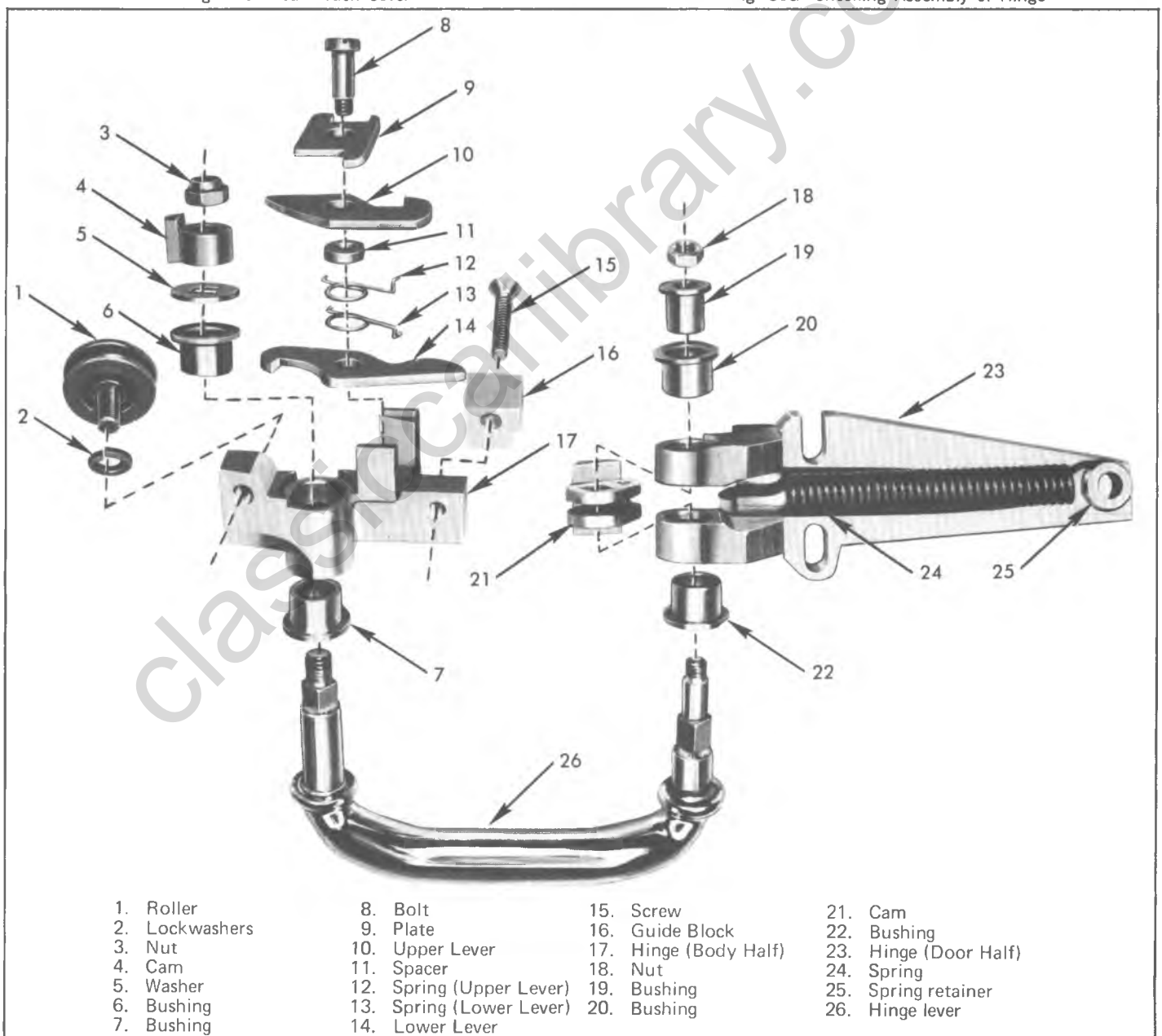

Fig. 30G—Checking Assembly of Hinge



- |                |                          |                       |                       |
|----------------|--------------------------|-----------------------|-----------------------|
| 1. Roller      | 8. Bolt                  | 15. Screw             | 21. Cam               |
| 2. Lockwashers | 9. Plate                 | 16. Guide Block       | 22. Bushing           |
| 3. Nut         | 10. Upper Lever          | 17. Hinge (Body Half) | 23. Hinge (Door Half) |
| 4. Cam         | 11. Spacer               | 18. Nut               | 24. Spring            |
| 5. Washer      | 12. Spring (Upper Lever) | 19. Bushing           | 25. Spring retainer   |
| 6. Bushing     | 13. Spring (Lower Lever) | 20. Bushing           | 26. Hinge lever       |
| 7. Bushing     | 14. Lower Lever          |                       |                       |

Fig. 29G—Upper Rear Hinge Components

## REAR DOORS

### REAR DOOR HINGE STRAP

#### Replacement

1. Remove strap release pin. See figure 31G.
2. Remove screws retaining strap to door.
3. Install strap to door. Torque retaining screws to specifications.

### REAR DOOR HINGE

#### Removal

1. Open door. Support door so that when hinge screws are removed door weight will be on support.
2. Remove hinge strap release pin.
3. Remove hinge-to-door bolts and remove door assembly.
4. Remove hinge-to-body bolts and hinge.

#### Installation

1. Install grommet into door hinge opening (if removed).
2. Install hinge into door. Snug bolts.
3. Install seal and retainer on body half of hinge (if removed).
4. Install hinge into body opening and install bolts.
5. Take care to compress seal between body and retainer and snug bolts.
6. Install hinge strap and its retaining pin.
7. Adjust door and torque hinge bolts to specification.

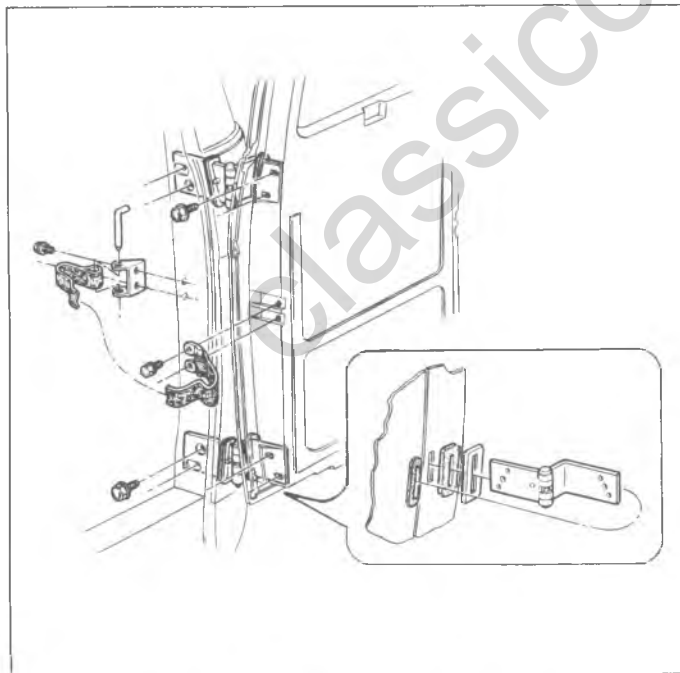

Fig. 31G—Rear Door Hinges and Strap

### REAR DOOR REMOTE CONTROL

#### Removal

1. Remove trim panel.
2. Disengage upper and lower latch rods from control by removing retaining clips. See figure 32G.
3. Remove remote control by removing its retaining screws.

#### Installation

1. Install remote control screws loosely.
2. Attach upper and lower control rods.
3. Rotate remote control lever clockwise, and hold in this position while torquing the screws to specifications.
4. Install the trim panel.

### REAR DOOR UPPER OR LOWER LATCHES AND/OR LATCH RODS

#### Removal

1. Remove trim panel.
2. Disengage rod from remote control assembly. See figure 32G.
3. Remove latch retaining screws and withdraw latch and control rod.
4. Remove spring clip retaining rod to latch.

#### Installation

1. Install latch rod to latch.

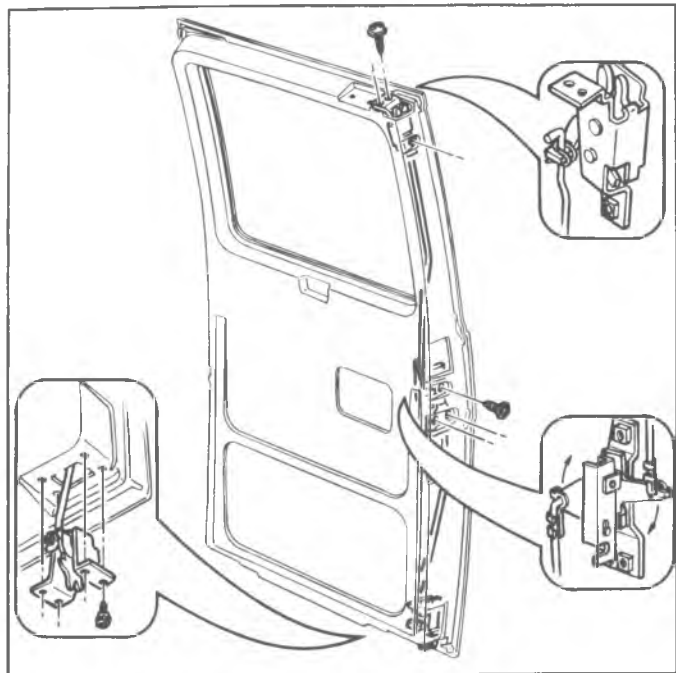

Fig. 32G—Remote Control and Latch



NOTE: When reinstalling the lower latch rod to control, the short straight section attaches to the latch.

2. Install latch and rod assembly into door and connect rod to remote control.
3. Install latch retaining screws and torque to specifications.
4. Adjust latch to strikers.

### REAR DOOR OUTSIDE HANDLE

#### Removal

1. Remove trim panel.
2. Remove door handle retaining screws, handle and gaskets. See figure 33G.

#### Installation

1. Apply grease to remote control where handle plunger makes contact.
2. Install handle and gaskets. Torque screws to specifications.
3. Install trim panel.

### REAR DOOR LOCK CYLINDER

#### Removal

1. Remove trim panel.
2. Remove remote control.
3. Remove lock cylinder retainer and lock cylinder.

#### Installation

1. Install lock cylinder and retainer.
2. Install remote control. Torque screws to specifications.
3. Install trim panel.

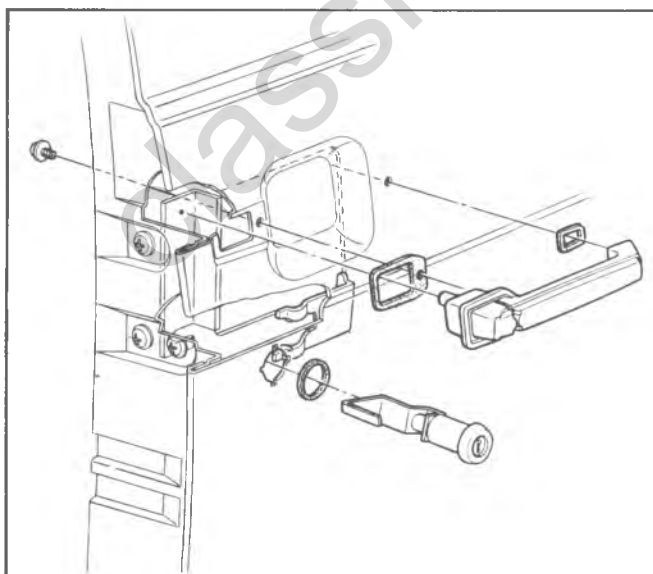

Fig. 33G—Outside Handle and Lock Cylinder

### REAR DOOR GLASS AND WEATHERSTRIP

Removal and installation procedures are the same as for the stationary body side windows. Refer to those procedures for rear door glass and weatherstrip replacement.

### REAR DOOR ADJUSTMENTS

NOTE: Door adjustments are provided by slotted holes, at hinge attachment, in body and door.

1. Remove or loosen door strikers and wedges.
2. Loosen door hinge bolts and adjust door to provide equal clearances between body and door around perimeter of door.
3. Adjust door in and out so that door panel is flush with body.
4. Install door strikers and wedges and adjust as outlined under door striker adjustment.

### REAR DOOR STRIKER AND WEDGE ADJUSTMENT

CAUTION: See CAUTION on page 1 of this section regarding Rear Door Striker fasteners.

1. Adjust striker by adding or deleting shims as necessary to obtain dimension as shown in figure 34G. This dimension can be checked by applying grease to the latch and slowly closing door until striker fully engages latch. Then open door and measure from grease impression to bottom of latch slot. Torque to specifications.
2. Adjust door wedge by adding or deleting shims as necessary so that wedge contacts ramp on body when door is closed. See figure 34G.

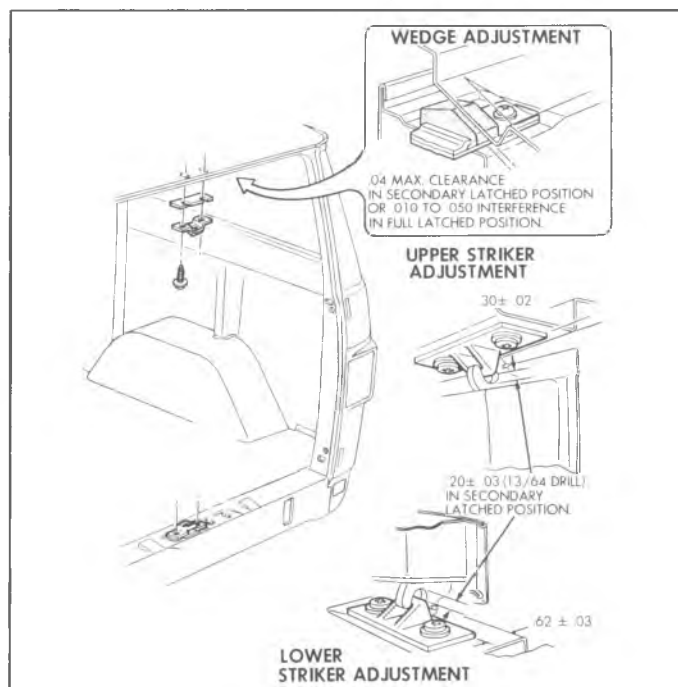

Fig. 34G—Rear Door Striker and Wedge Adjustment

## SEATS

**CAUTION:** See *CAUTION* on page 1 of this section regarding fasteners used on seats and seat belts.

## DRIVERS SEAT

## Seat Adjuster

## Replacement

1. Remove seat by removing nuts securing seat adjuster to seat riser.
2. Remove adjuster from seat. See figure 35G.
3. Install seat adjuster to seat. Torque bolts to specifications.
4. Install seat onto seat riser, and torque nuts to specifications.

## SEAT RISER

## Replacement

1. Remove seat and adjusters as an assembly by removing nuts securing seat to riser.
2. Remove nuts securing seat riser to floor.
3. Install seat riser to floor. Torque nuts to specifications.
4. Install seat and torque nuts to specifications.

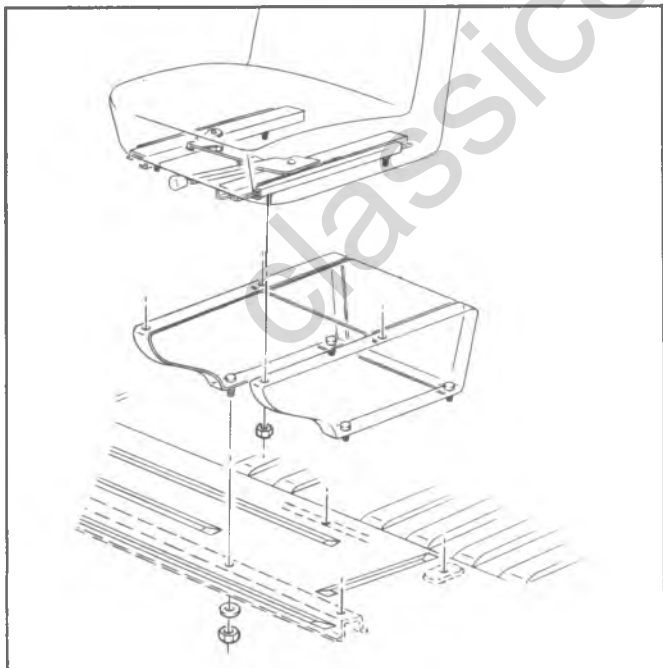

Fig. 35G—Driver's Seat

## PASSENGER SEAT—MOUNTING BRACKETS

## Removal

1. Remove seat and brackets from seat riser. See figure 36G.
2. Remove brackets from seat.

## Installation

1. Install brackets to seat. Torque to specifications.
2. Install seat to seat riser. Torque to specifications.

## SEAT RISER

## Removal

1. Remove seat and mounting bracket as an assembly.
2. Remove riser from floor.

## Installation

1. Install riser to floor. Torque nuts to specifications.
2. Install seat to riser. Torque nuts to specifications.

## BENCH SEATS—FIGS. 37G, 38G

## Seat and/or Seat Support

## Removal

1. Remove bolts securing seat legs to floor.
2. Remove seat assembly.

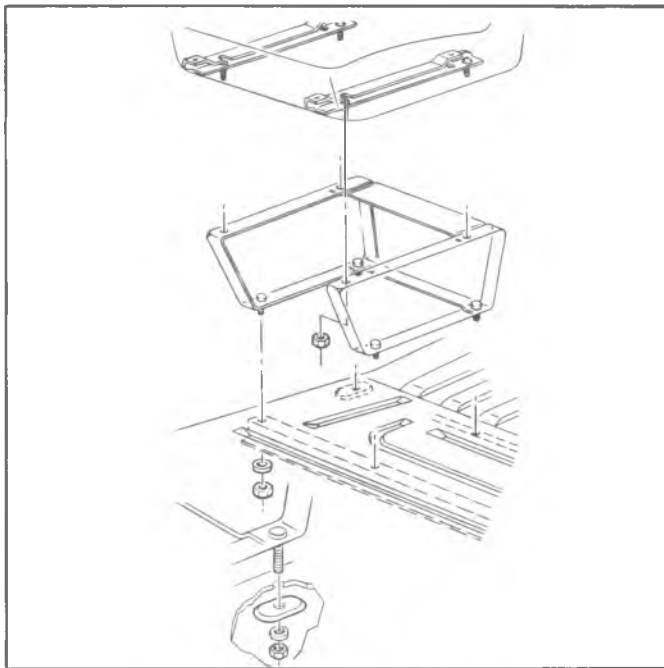

Fig. 36G—Passenger Seat

**NOTE:** After removing the rear seat, reinstall the bolts into the anchor nuts to seal the openings from dirt and foreign matter.

3. Remove legs and support assembly.

#### Installation

1. Attach leg and support assembly to seat. Torque to specifications.
2. Attach seat belts. Torque bolts to specifications.

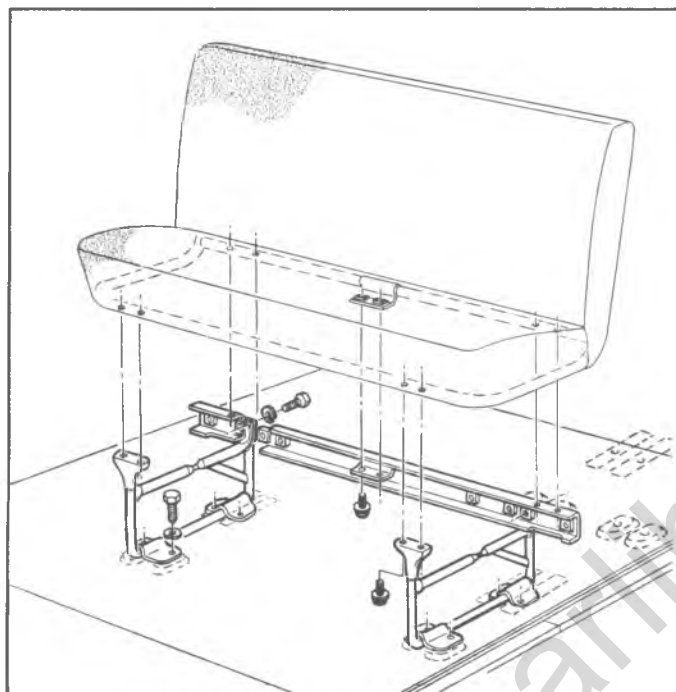

Fig. 37G—Bench Seat 2nd or 3rd Position

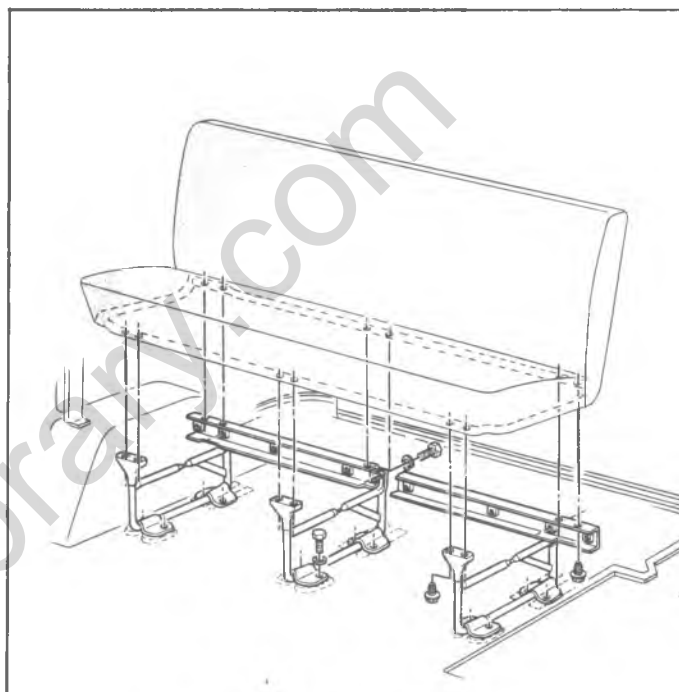

Fig. 38G—Bench Seat 4th Position

**CAUTION:** *Shoulder of Bolt must bottom on weld nut.*

3. Attach seat to floor. Torque bolts to specifications.

#### CARE AND CLEANING OF SEATS

Instructions on care and cleaning of interior soft trim may be found in "C-K Models—Seats", earlier in this section.

## SPECIAL TOOLS

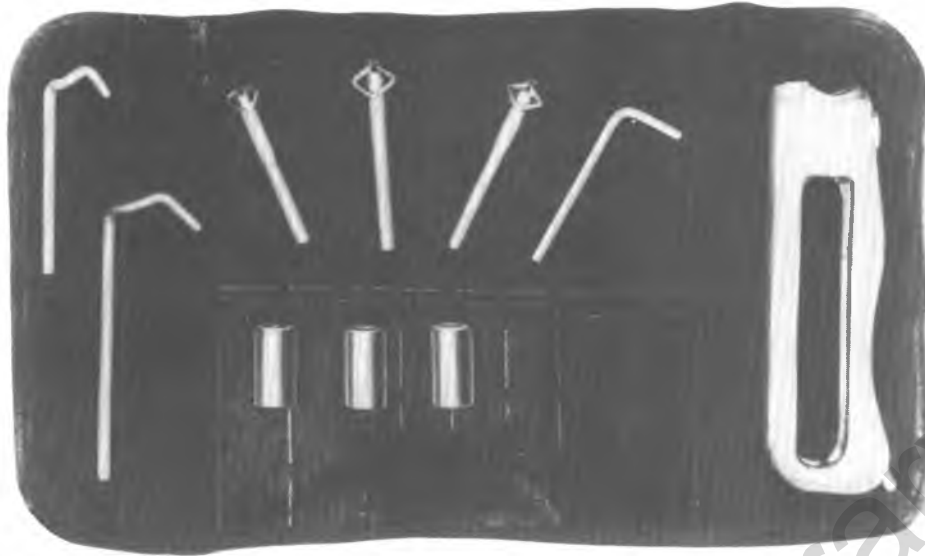

1



2

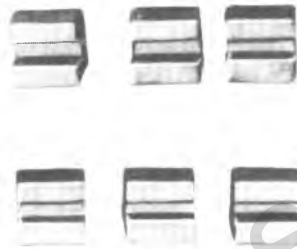

3



4



5

- 1. J-2189 Weatherstrip Tool Set
- 2. J-22585 Front Door Hinge, Bolt Wrench
- 3. J-22577 Windshield Checking Blocks
- 4. J-7797 Door Handle Clip Remover
- 5. J-23457 Door Striker Bolt Remover and Installer

Fig. 1T—Special Tools

## SECTION 2

## FRAME

## INDEX

Description 10-30 Series Truck .....	2-1	Frame Repair.....	2-2
Maintenance .....	2-1	Welding .....	2-2
Frame Alignment.....	2-1	Bolting.....	2-2
Horizontal Check .....	2-2	Underbody Alignment .....	2-2
Vertical Check.....	2-2		

## DESCRIPTION

Light duty 10-30 Series frames are of the ladder channel section riveted type.

Figure 1 illustrates typical light duty frames with crossmembers, body mounts and suspension attaching brackets. This section also included general instructions for checking frame alignment and recommendations on frame repair.

The G-Van frame side rails, cross sills and outriggers are part of the underbody assembly which is a welded unit.

Misalignment of the underbody can affect door opening fits and also influence the suspension system, causing suspension misalignment. It is essential, therefore, that underbody alignment be exact to within - 1/16" of the specified dimensions.

## MAINTENANCE

## UNDERBODY AND FRAME INSPECTION

## UNDERBODY INSPECTION

Raise the vehicle on a hoist (preferably a twin-post type). Check for obvious floor pan deterioration.

Check for loose dirt and rust around the inside of the floor pan reinforcement member access holes. This is the first indication that corrosion may exist in hidden areas, and that repairs might be required before the final cleaning and protective treatment is performed.

Using a chisel, ensure that the drain provisions in the floor pan reinforcement members are open.

There are drain holes in the body side panels also. These holes can be opened by using a punch or drift. The side panel drain holes are in the rear section of the rocker panels, and in the lower rear quarter panels.

## FRAME ALIGNMENT

Horizontal frame checking can be made with trammig gauges applied directly to the frame or by transferring selected points of measurement from the frame to the floor by means of a plum bob and using the floor layout for measuring. Figure 2 may be used as a general guide in the selection of checking points; however, selection of these points is arbitrary depending on accessibility and convenience. An important point to remember is that for each point selected on one side of the frame, a corresponding point on the opposite side of the frame

must be used for vertical checks, opposite and alternate sides for horizontal checks.

## Vehicle Preparation

Points to remember when preparing vehicle for frame checking:

1. Place vehicle on a level surface.
2. Inspect damaged areas for obvious frame misalignment to eliminate unnecessary measuring.
3. Support vehicle so that frame sidemembers are parallel to the ground.

## Trammig Sequence

1. Dimensions to bolts and/or holes in frame extend to dead center of the hole or bolt.

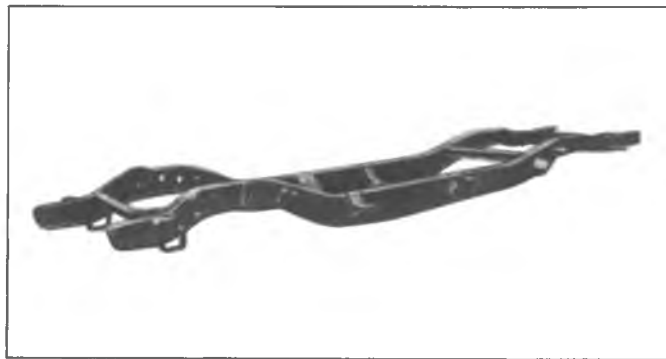

Fig. 1—10-30 Series Frame—Typical

## 2-2 FRAME

2. Dimensions must be within 3/16".
3. If a tram bar is used, for horizontal alignment "X" - check from opposite and alternate reference points AA, BB and CC, as illustrated by the lines in Figure 2. Error will result if a tram bar is not level and centered at the reference points.
4. Obtain vertical dimensions and compare the differences between these dimensions with the dimensions as shown in chart.

### Horizontal Check

1. Measure frame width at front and rear. If widths correspond to specifications, draw centerline full length of vehicle halfway between lines indicating front and rear widths. If frame widths are not correct, layout centerline as shown in Step 4.
2. Measure distance from centerline to corresponding points on each side of frame layout over entire length. Opposite side measurement should correspond within 3/16".
3. Measure diagonals marked A, B and C. If the lengths of intersecting diagonals are equal and these diagonals intersect the centerline, frame area included between these points of measurement may be considered in alignment.
4. If front or rear end of frame is damaged and width is no longer within limits, frame centerline may be drawn through the intersection of any two previously drawn pairs of equal, intersecting diagonals.

### Vertical Check

Vertical dimensions are checked with a tramping bar from indicated points on the frame (figs. 3 and 4). For example, if the tram bar is set at point B with a vertical pointer length of 8-1/4 inches, and at point E with a vertical pointer length of 5-1/4 inches (a height difference of 3 inches), the tram bar should be parallel with the frame. If the area is twisted or misaligned in any way, tram bar will not be parallel. Placing the tram bar vertical pointers on opposite sides of the frame side rail is preferable in that frame twist will show up during this vertical check. Figures 3 and 4 show typical checking points, with dimensions for various frames shown in the chart below.

### Frame Repair

#### Welding

Before welding up a crack in frame, a hole should be

drilled at the starting point of the crack to prevent spreading. Widen V groove crack to allow complete weld penetration.

NOTE: Do not weld into corners of frame or along edges of side rail flanges. Welding at these points will tend to weaken the frame and encourage new cracks.

#### Bolting

Wherever rivets or failed bolts are replaced, bolt hole must be as near the O.D. of the bolt as possible to prevent bolt from working and wearing. Drill out and line ream hole (or holes) to the bolt O.D.

### UNDERBODY ALIGNMENT

One method of determining the alignment of the underbody is with a tram gauge which should be sufficiently flexible to obtain all necessary measurements up to three quarters the length of the vehicle. A good tramping tool is essential for analyzing and determining the extent of collision misalignment present in underbody construction.

#### MEASURING (Fig. 5)

To measure the distance accurately between any two reference points on the underbody, two specifications are required.

1. The horizontal dimension between the two points to be trammed.
2. The vertical dimension from the datum line to the points to be trammed.

The tram bar should be on a parallel to that of the body plane. The exception to this would be when one of the reference locations is included in the misaligned area; then the parallel plane between the body and the tram bar may not prevail. After completion of the repairs, the tram gauge should be set at the specified dimension to check the accuracy of the repair operation.

### EXCESSIVE BODY DAMAGE

If damage is so extensive that key locations are not suitable as reference points, repair operations should always begin with the underbody area. All other components should be aligned progressively from this area. Unlike the conventional type of frame design, the unitized type of body construction seldom develops the two conditions of "twist" and "diamond" in the underbody area as a result of front or rear end collisions, therefore, there usually is an undamaged area suitable as a beginning reference point.

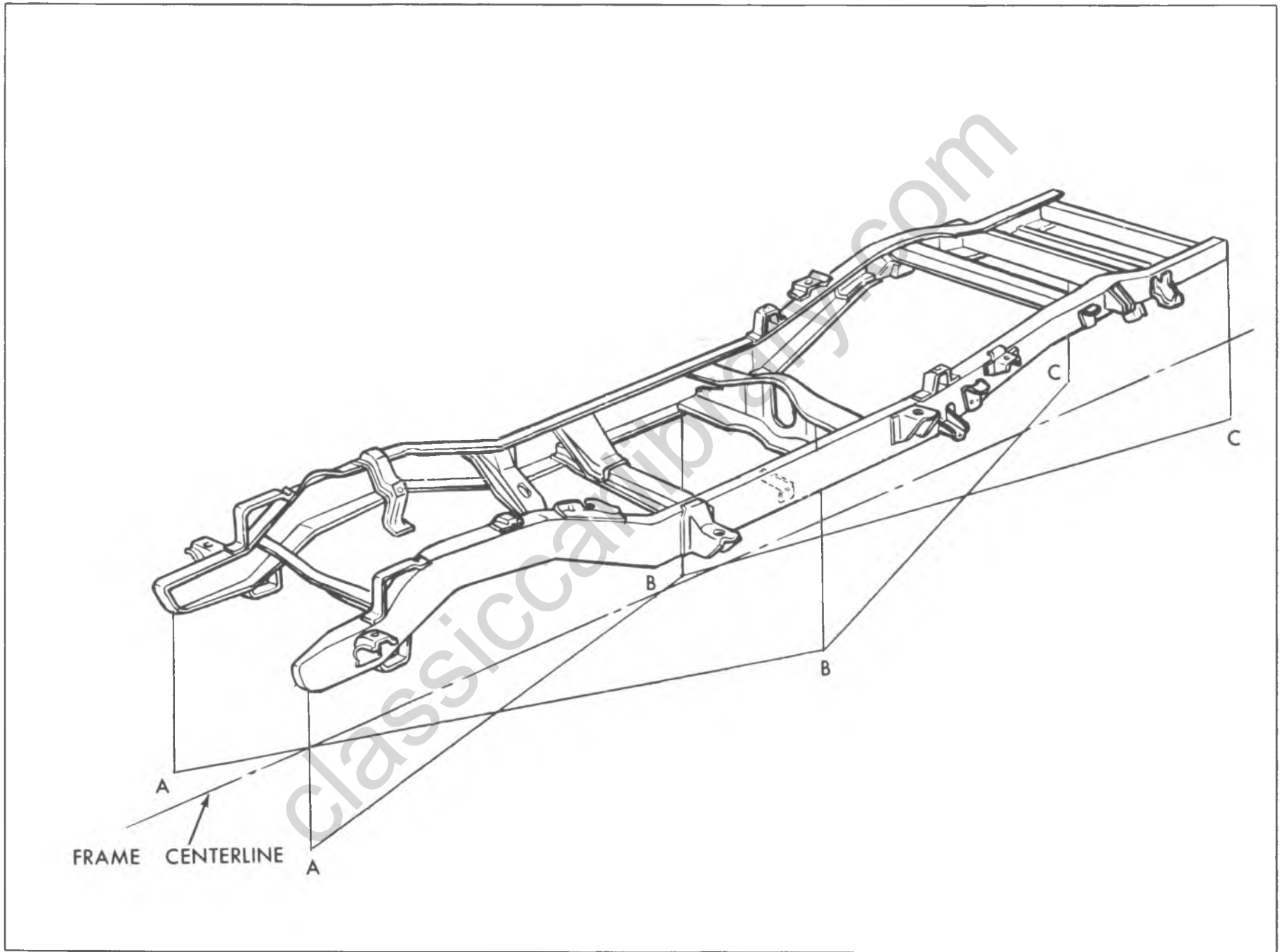

Fig. 2--Frame Horizontal Checking - Typical

2-4 FRAME

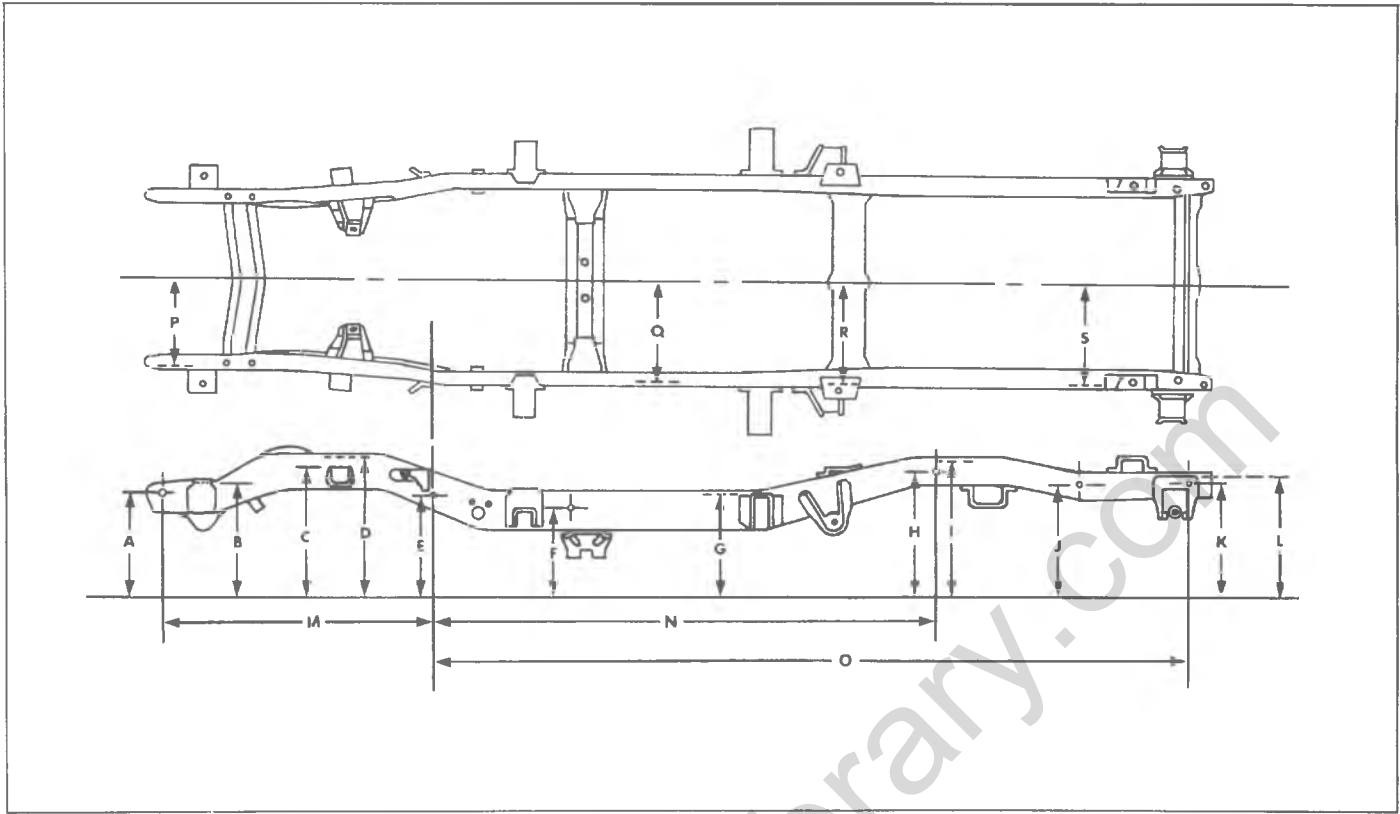

Fig 3-KA Frame

Model	A	B	C	D	E	F	G	H	I	J	K	L	M	N	O	P	Q	R	S
CA107	9-3/8	11-7/8	13-3/8	16	10-1/4	7-1/8	10	13-3/8	15-1/2	12	11-3/8	13-3/8	43	92	127-3/4	14	16-7/8	19-1/8	16-7/8
CA109	9-3/8	11-7/8	13-3/8	16	10-1/4	7-1/8	10	13-3/8	15-1/2	12	11-3/8	13-3/8	43	104	134	14	16-7/8	19-1/8	16-7/8
CA209	9-3/8	11-7/8	13-3/8	16	10-1/4	7-1/8	10	13-3/8	15-1/2	12	11-3/8	13-3/8	43	104	134	14	16-7/8	19-1/8	16-7/8
CA <sup>210</sup> <sub>310</sub>	9-3/8	11-7/8	12-3/4	16	7-1/2	-	10	10	15-1/8	-	10-1/4	13-3/8	49	90-3/8	158-1/4	14	16-7/8	16-7/8	16-7/8
CA314	9-3/8	11-7/8	12-3/4	16	7-1/2	6-1/8	10	8-3/8	17-1/8	14-1/4	14-1/4	17-1/8	49	90	180-1/2	14	16-7/8	16-7/8	16-7/8
KA107	9-3/8	11-7/8	13-1/8	16	10-1/4	7-1/8	10	13-3/8	14-5/8	12	10-3/4	13-3/8	43	92	127-3/4	14	16-7/8	16-7/8	16-7/8
KA <sup>109</sup> <sub>209</sub>	9-3/8	11-7/8	13-1/8	16	10-1/4	7-1/8	10	13-3/8	15-1/2	12	10-3/4	13-3/8	43	104	139-3/4	14	16-7/8	16-7/8	16-7/8
PA100	9-3/8	11-7/8	13-3/8	16	10-1/4	7-1/8	10	13-3/8	15-1/2	12	10-3/4	13-3/8	43	79	114-5/8	14	16-7/8	19-1/8	16-7/8
PA <sup>208</sup> <sub>308</sub>	9-3/8	11-7/8	12-3/4	16	13-1/2	7-1/2	10	10	15-1/8	11-5/8	11-1/4	13-3/8	31-5/8	99-3/4	175-3/4	16-7/8	16-7/8	16-7/8	16-7/8
PA <sup>210</sup> <sub>310</sub>	9-3/8	11-3/8	12-3/4	16	13-1/2	7-1/2	10	10	15-1/8	11-5/8	11-1/4	13-3/8	31-1/2	107-3/4	183-3/4	16-7/8	16-7/8	16-7/8	16-7/8
PA314	9-3/8	11-7/8	12-3/4	16	13-1/2	7-1/2	10	10	15-1/8	11-5/8	11-1/4	13-3/8	31-1/2	131-3/4	207-3/4	16-7/8	16-7/8	16-7/8	16-7/8
CA105	9-3/8	11-7/8	13-3/8	16	10-1/4	7-1/8	10	13-3/8	15-1/2	12	-	13-3/8	43	81	-	14	16-7/8	19-1/8	16-7/8
KA105	9-3/8	11-7/8	13-1/8	16	10-1/4	7-1/8	10	13-3/8	14-5/8	12	10-3/4	13-3/8	43	81	116-3/4	14	16-7/8	16-7/8	16-7/8
PE 31132 (137)	9-1/4	11-5/8	12-5/8	15-3/4	13-3/8	7-3/8	9-3/4	9-3/4	15	11-1/2	11-1/8	13-1/8	31-1/2	111-3/4	187-3/4	14	16-7/8	16-7/8	16-7/8
PE 31432 (157)	9-1/4	11-5/8	12-5/8	15-3/4	13-3/8	7-3/8	9-3/4	9-3/4	15	11-1/2	11-1/8	13-1/8	31-1/2	131-3/4	207-3/4	14	16-7/8	16-7/8	16-7/8



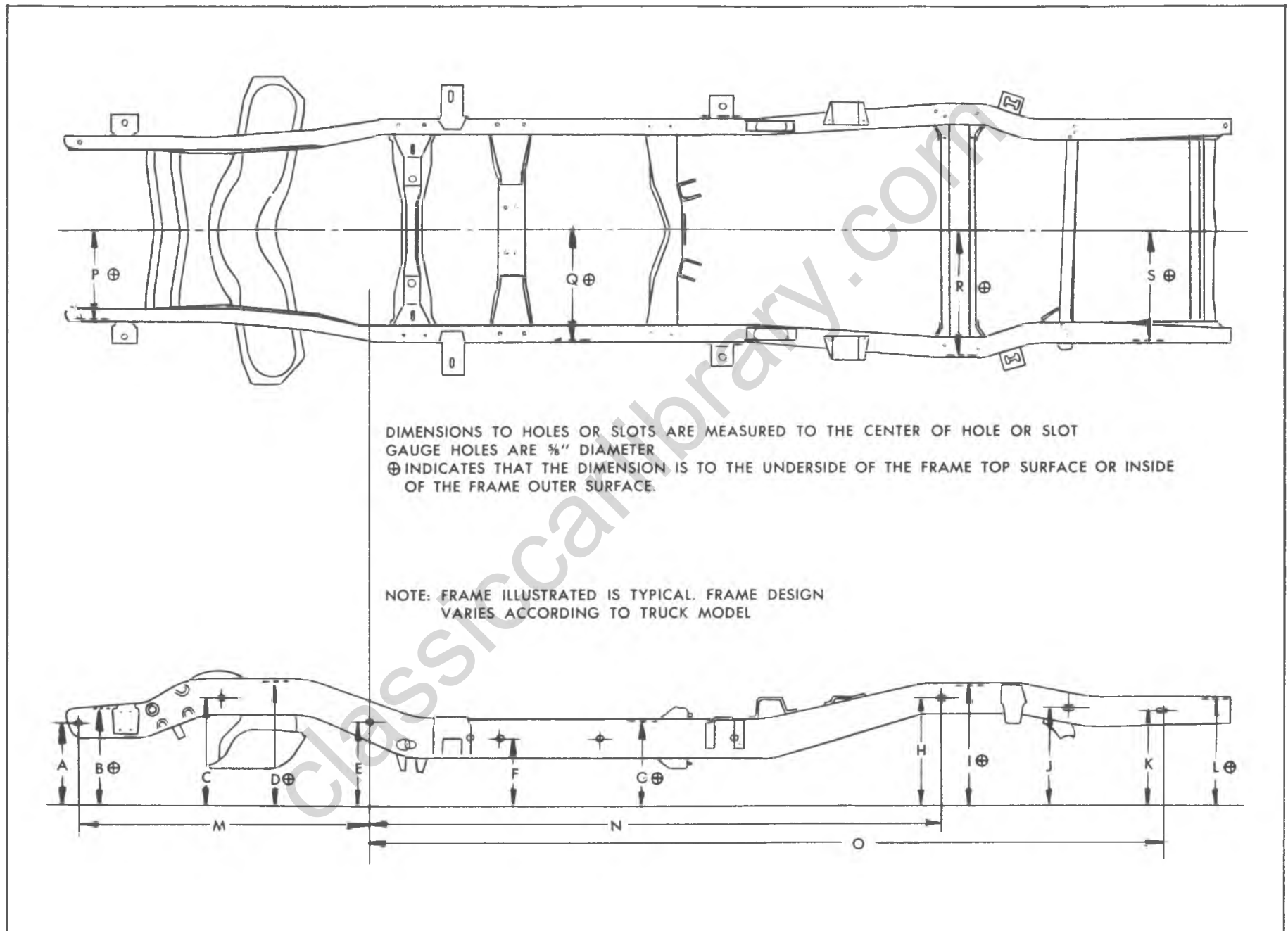

Fig. 4-10-30 Series Truck Frame

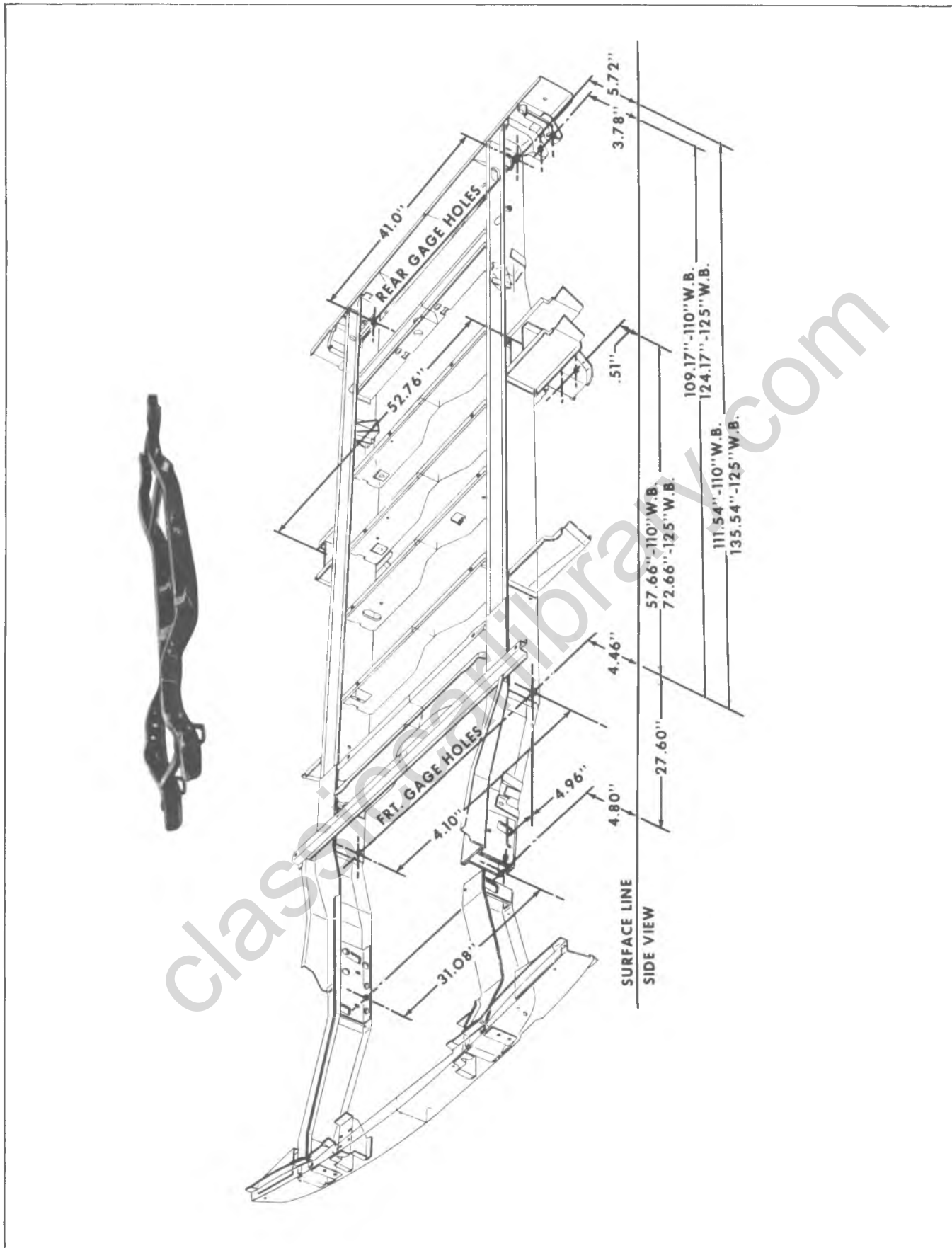

Fig. 5--Underbody Reference Points · G.Van

## SECTION 3

# FRONT SUSPENSION

The following caution applies to one or more steps in the assembly procedure of components in this portion of the manual as indicated at appropriate locations by the terminology "See Caution on page 1 of this Section".

**CAUTION THIS FASTENER IS AN IMPORTANT ATTACHING PART IN THAT IT COULD AFFECT THE PERFORMANCE OF VITAL COMPONENTS AND SYSTEMS, AND/OR COULD RESULT IN MAJOR REPAIR EXPENSE. IT MUST BE REPLACED WITH ONE OF THE SAME PART NUMBER OF WITH AN EQUIVALENT PART IF REPLACEMENT BECOMES NECESSARY. DO NOT USE A REPLACEMENT PART OF LESSER QUALITY OR SUBSTITUTE DESIGN. TORQUE VALUES MUST BE USED AS SPECIFIED DURING REASSEMBLY TO ASSURE PROPER RETENTION OF THIS PART.**

### CONTENTS OF THIS SECTION

Front Suspension - 2 Wheel Drive.....	3-2
Front Suspension - 4 Wheel Drive.....	3-38

### INDEX

General Description.....	3-2	Component Parts Replacement .....	3-16
Theory of Operation .....	3-4	Wheel Hubs and Bearings.....	3-16
K-Series Suspension.....	3-4	Removal .....	3-16
Independent Suspension.....	3-4	Inspection .....	3-16
Steering Knuckle and Wheel Spindle .....	3-5	Repairs .....	3-17
Control Arms .....	3-5	Bearing Cups—Replace .....	3-17
Ball Joints .....	3-5	Wheel Stud Replacement.....	3-17
Coil Springs .....	3-5	Installation .....	3-17
Leaf Springs .....	3-5	Shock Absorbers .....	3-17
Shock Absorbers .....	3-5	Removal .....	3-17
Wheel Alignment .....	3-9	Installation .....	3-17
Front Suspension Geometry.....	3-9	Stabilizer Bar.....	3-17
Caster .....	3-9	Coil Spring .....	3-18
Camber.....	3-10	Leaf Spring - K Series.....	3-19
Toe-In .....	3-10	Upper Control Arm Pivot Shaft	
Toe-Out on Turns.....	3-10	and Bushings (Steel).....	3-19
Steering Axis Inclination .....	3-10	Lower Control Arm Pivot Shaft	
Preliminary Adjustments.....	3-10	and Bushings (Steel).....	3-20
Maintenance and Adjustments.....	3-12	Upper Control Arm Assembly .....	3-21
Wheel Bearing—Check Adjustment.....	3-12	Rubber Bushings .....	3-21
Front Alignment Description .....	3-12	Lower Control Arm Assembly.....	3-22
Camber.....	3-13	Rubber Bushings .....	3-22
Caster.....	3-13	Ball Joint Service.....	3-22
How to Determine Caster.....	3-13	Inspection .....	3-23
Tow-In .....	3-14	Replacement .....	3-24
Definitions .....	3-14		

### 3-2 FRONT SUSPENSION

Steering Knuckle/Steering Arm .....	3-25	Front Suspension .....	3-27
Removal .....	3-26	Ball Joint.....	3-30
Installation .....	3-26	Shock Absorber.....	3-31
Crossmember and Suspension Unit.....	3-26	On Vehicle .....	3-31
Removal.....	3-26	Bench .....	3-32
Installation .....	3-26	Bearings and Races.....	3-33
Diagnosis.....	3-27	Special Tools.....	3-37

## GENERAL DESCRIPTION

The GM 10-30 series Truck line except K Series incorporates an independent coil spring front suspension system. (Figs. 1 and 2).

The control arms are of unequal length (S.L.A. Type) and is used on all 10, 20 and 30 series vehicles without 4 wheel drive.

This suspension system consists of upper and lower control arms pivoting on steel threaded or rubber bushings on upper and lower control arm shafts. The lower control arms are attached to the crossmember. The

upper control arms are attached to a frame bracket. These control arms are connected to the steering knuckle through pivoting ball joints.

A coil spring is located between the lower control arm and a formed seat in the suspension crossmember, thus the lower control arm is the load carrying member. Double acting shock absorbers are also attached to the lower control arms and connect with the frame to the rear on the upper end. The front wheel bearings are tapered roller type and are used on all models.

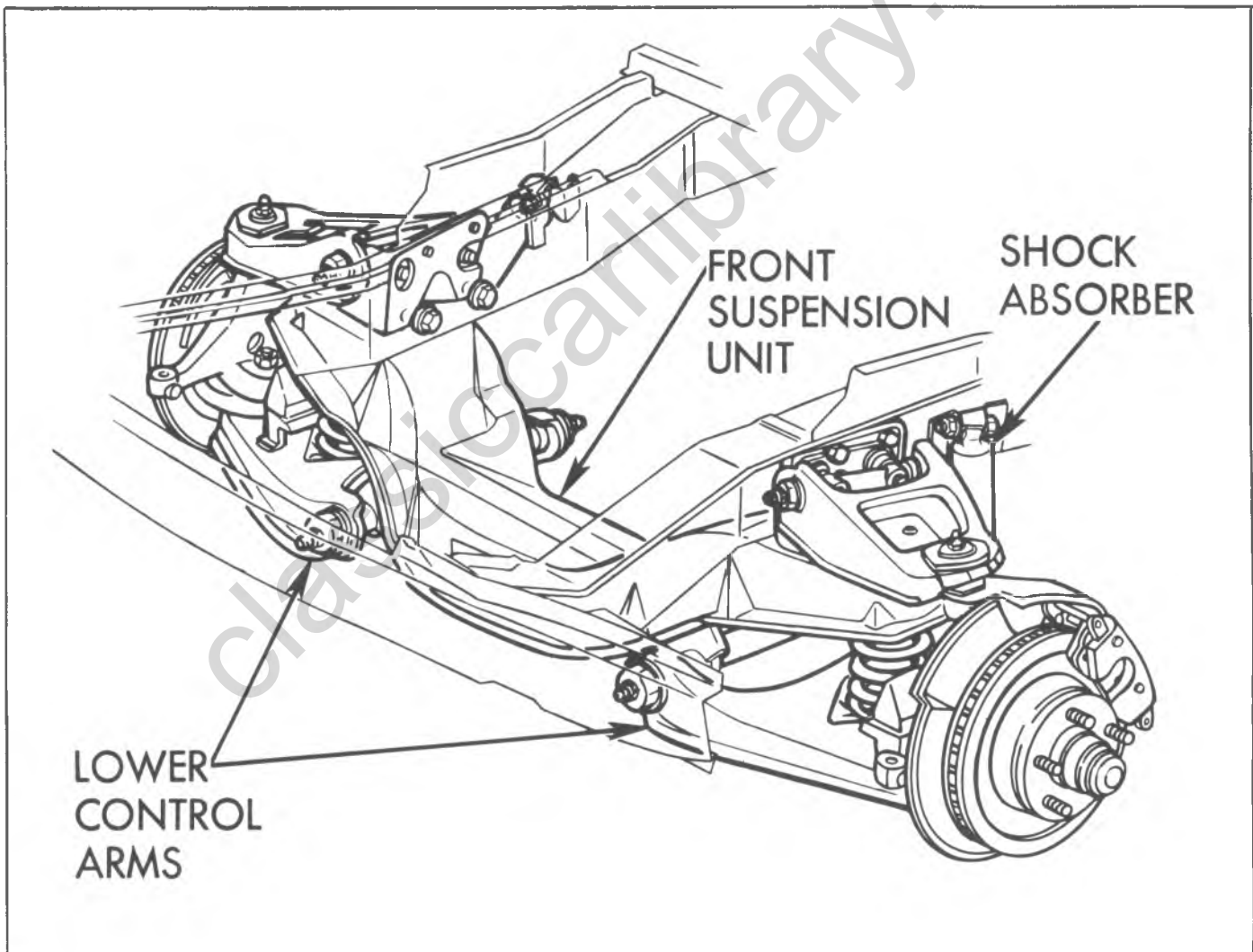
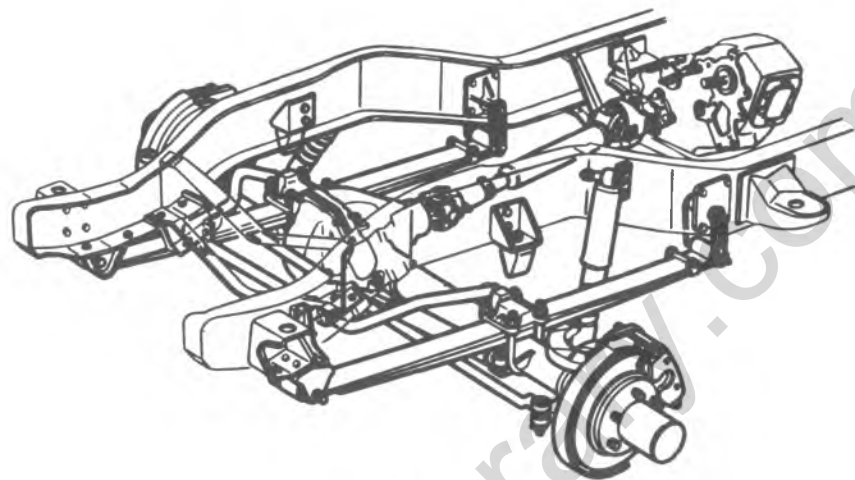
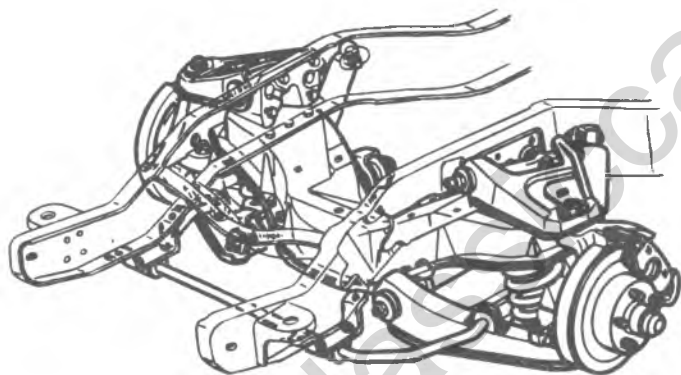

Fig. 1—Front Suspension - G-30—Typical



**K-10-20**



**C-10  
G-10-20**

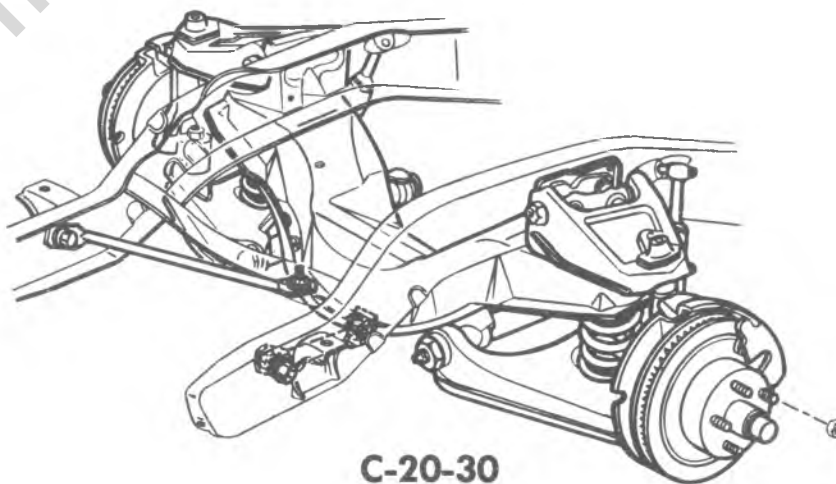

**C-20-30  
G-30  
P-10-30**

Fig. 2—Front Suspension C-P-K Typical

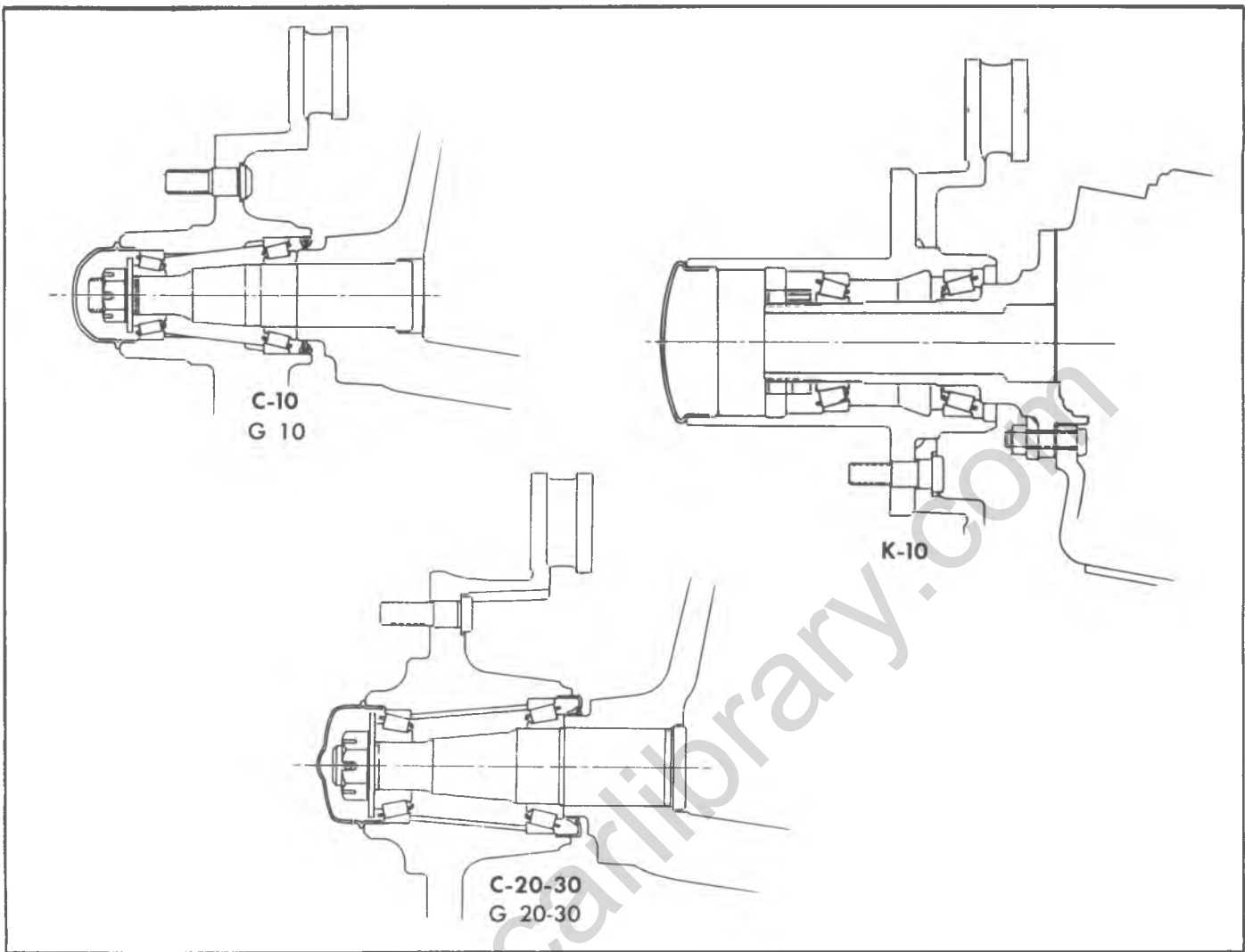

Fig. 3—Wheel Hubs and Bearings

## THEORY OF OPERATION

The front suspension can be divided into two types, the **CONVENTIONAL**, such as used on General Motors K Series trucks, or the **INDEPENDENT**, such as used on all other General Motors light duty trucks.

The description of **caster**, **camber**, **toe-in**, **toe-out** — on turns and steering axis or kingpin inclination is the same for conventional or independent types of suspensions. The description of the control arms and related parts as well as adjustment methods is intended for the independent front suspension only.

### K-SERIES SUSPENSION

The K-Series suspension system, as described here, refers to leaf springs and a tubular axle. The tubular axle attached to the vehicle through the leaf springs that are secured to the axle on a spring pad. The spring ends, called eyes, are attached to the vehicle frame through hangers.

The steering knuckle and wheel spindle attach to the axle ends through ball joints. Caster can not be changed on this particular vehicle and is designed and built into the suspension. The camber setting is built into the axle and cannot be changed. Toe-in is changed in a manner similar to all other G.M. vehicles.

### INDEPENDENT SUSPENSION

The independent suspension system, as described here, refers to coil springs and control arms. Control arms and coil springs are covered later in this section.

The term “independent suspension” describes a method of supporting the chassis on the wheels without the use of rigid axles. When a pair of wheels are mounted to a

rigid axle and one of them passes over a bump the axle executes an angular movement in the (front view) vertical plane and both of the wheels perform movements of the same angular magnitude. With independent suspension the movement of the two wheels are not interdependent; one wheel does not force the other wheel to deflect.

With the independent suspension, the steering knuckle and wheel spindle are connected to the vehicle through ball joints and control arms.

### Steering Knuckle and Wheel Spindle

The wheel spindle is the unit that carries the hub and bearing assembly with the aid of the knuckle assembly. The hub assembly has also become the brake disc assembly.

As pointed out under conventional and independent suspensions, the wheel spindle is connected to the vehicle through a steering knuckle and ball joints.

The spindle carries the entire wheel load. In order to reduce friction, on the sprindle and wheel hub, wheel bearings are provided. The design and placement of these bearings on the spindle is such that the center plane of the wheel is closer to the center plane of the inner bearing than the outer bearing. The reason for this is to bring the wheel as close as possible to the knuckle axis. For this same reason the inner bearing will usually be larger than the outer bearing. Wheel bearing service is covered in detail elsewhere in this section.

### Coil Spring

Coil springs are just what their name implies. They are coils of steel wire. A coil spring can be installed on the front suspension or rear suspension of a vehicle with the method of attachment varying to suit the application.

On the front suspension the lower control arm provides the seat for the coil spring with the upper end housed within the frame crossmember. The function of the coil spring is the same as the leaf spring, that is, to cushion shock imparted to the wheel by road roughness or obstacles.

Since a coil spring provides little directional stability control arms are provided and connect between the vehicles frame and axle assembly.

Shock absorbers are used with the springs and are covered elsewhere in this section.

## CONTROL ARMS

### (Independent Suspension)

The front control arms are said to be the SLA type (Short and Long Arm). The control arms attach to the vehicle with bolts at their inner pivot points and to the steering knuckle (which is part of the front wheel spindle) at their outer points. The outer attachment is made through ball joints secured to the control arms and

bolted to the steering knuckle. This arrangement allows the front wheel suspension to move up and down with respect to the vehicle frame (spring action) and swing at various angles for vehicle steering.

### Control Arm Bushings

Two different types of bushings are used in independent suspension trucks. G-10 and 20 series and C-10 series trucks use rubber bushings for both upper and lower control arms. P-10 series has rubber upper control arm bushings. All P series lower, P-20/30 upper C-20/30 and G-30 upper and lower use steel bushed control arms. The rubber bushings provide a better more enjoyable ride, while the steel bushings are needed for heavy duty applications.

### BALL JOINTS (Fig. 5)

Ball joints are used to connect the control arms to the steering knuckle. The upper ball joint is usually riveted to the control arm and connects to the steering knuckle through a tapered stud that is held in position with a castellated nut and a cotter pin. The lower ball joint is usually pressed into the control arm and connects to the steering knuckle through a tapered stud that is held in position with a castellated nut and a cotter pin.

A ball joint stud, nut and rubber seal is about all your eye will see of the ball joint assembly. The function of the rubber seal is to retain the lubricating grease, which it contains, and to protect this grease from contamination by water or foreign material (sand, dirt, etc.). If this seal is damaged (torn or pulled off its metal retainer) the ball joint should be replaced. Check the Service procedure for inspection and replacement of a ball joint suspected of being in need of replacement.

NOTE: Grease fittings on ball joints should be wiped clean before applying grease to the joint.

## SHOCK ABSORBERS

Shock absorbers are hydraulic devices that help to control the up-and-down and rolling motion of a vehicle

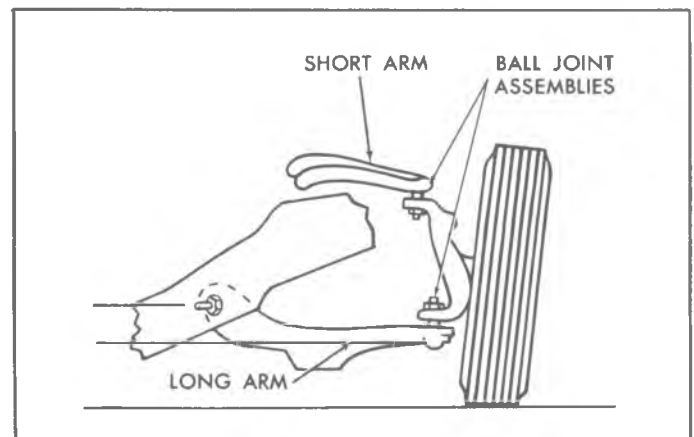

Fig. 4—Control Arms

### 3-6 FRONT SUSPENSION

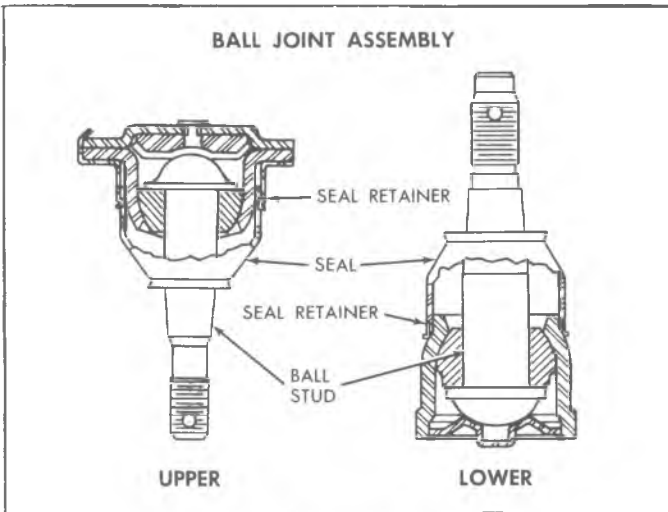

Fig. 5—Ball Joints-Typical

body while at the same time controlling wheel and axle motions.

The vehicle's springs support the body, but shock absorbers work with the springs to control movements of the body, wheel, and axle for smooth driving. This is accomplished by changing the movements of the spring (kinetic energy) into heat energy. Therefore, a shock absorber may be considered as a damper to control the energy stored up by the springs under load. The main components of a shock absorber are shown in Figure 6.

#### Operation

A shock absorber is sometimes compared to a water pistol. Of course, there are many steps between a water pistol and a shock absorber, but both are damping devices and both use the same principle—they force an incompressible liquid through small openings.

There are usually four shock absorbers on a vehicle; one located near each wheel. They are direct-acting because of their direct connection between the vehicle frame (body) and the axle (or wheel mounting member). They are also double-acting because they control motion in both directions of the suspension travel. Up movements of the body are termed rebound and down movements, compression.

The compression movement of the shock absorber causes the piston to move downward with respect to the cylinder tube (figure 7), transferring fluid from chamber B to chamber A. This is accomplished by fluid moving through the outer piston holes and unseating the piston intake valve. Since all the fluid in chamber B cannot pass into chamber A due to the volume of the piston rod, the fluid equivalent to the rod volume is discharged out of the compression valve into chamber C of the reservoir with a corresponding compression of the air in chamber D. Compression control is the combination of load due to the compression valve and of load due to the piston intake valve.

The rapid movement of the fluid between the chambers during the rebound and compression strokes can cause

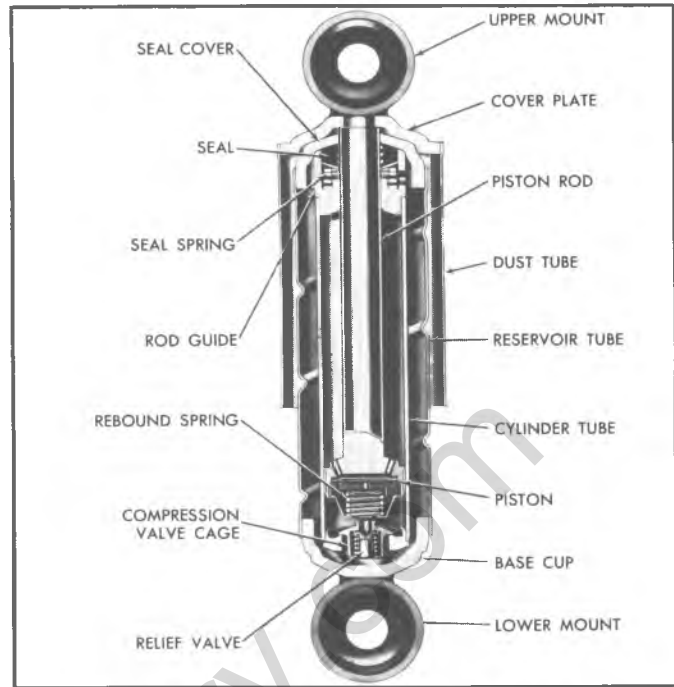

Fig. 6—Major Components of a Shock Absorber

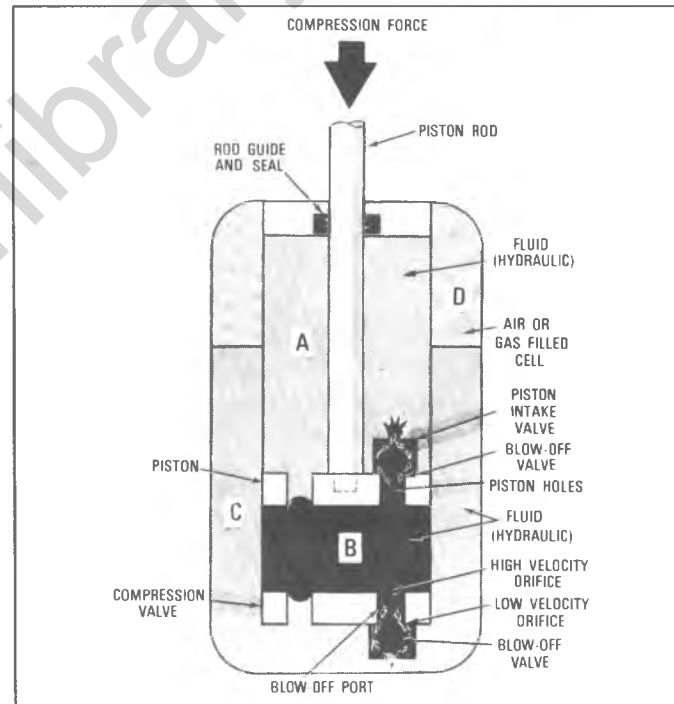

Fig. 7—Shock Absorber Compression Schematic

aeration or foaming of the fluid (aeration is the mixing of free air and the shock fluid). When aeration occurs, the shock develops lag (piston moving through an air pocket which offers no resistance). Two means of eliminating aeration are utilized. One is a spiral groove reservoir tube, Figure 8, which breaks up the air bubbles in the fluid. The other is a gas filled cell, Figure 9, which replaces the free air in a shock absorber.



This cell, in the reservoir, acts the same as an air chamber, expanding and contracting to compensate for the volume of the piston rod. But since it is a gas filled cell, there is no free air to mix with the fluid; thus, aeration is eliminated.

A rebound or extension stroke, Figure 10, will cause the pressure in chamber B to fall below that in chamber C. As a result, the compression valve will unseat and allow fluid to flow from chamber C into chamber B. Chamber D contains air which expands to compensate for the piston rod volume being removed. Simultaneously, fluid in chamber A will be transferred into chamber B through the inner piston holes and the rebound valve. Rebound control is determined by the piston rebound varying.

Sometimes shock absorbers are used to limit the rebound travel of a suspension system. This type of usage is primarily for front suspension systems and permits the rubber rebound bump stop to be omitted. Shock absorbers used in this manner have a different type of internal construction which controls the rebound stroke. This construction is called "rebound cut-off". On the rebound stroke, all fluid passing from chamber A to chamber B, see Figure 10, through the piston valving parts must first flow through the piston rod. The fluid flows through the piston rod by means of intersecting holes, one along the axis of the piston rod and the other perpendicular to it. As the shock absorber approaches the end of the rebound stroke, the passage in the piston rod enters the rod guide, gradually restricting the flow of the fluid. As the flow is restricted, the control of the shock absorber increases. When the passage is completely closed off by the rod guide, see Figure 11, a small amount of fluid is trapped in chamber A creating a hydraulic stop which limits the full rebound travel of the suspension system.

As the piston moves, forcing fluid through calibrated orifices, pressure increases within the cylinder. This pressure acting against the effective area of the piston determines the resistance or control provided by the shock absorber. Low piston velocities create low pressures, whereas high piston velocities with the same orifice result in considerably higher pressures. For

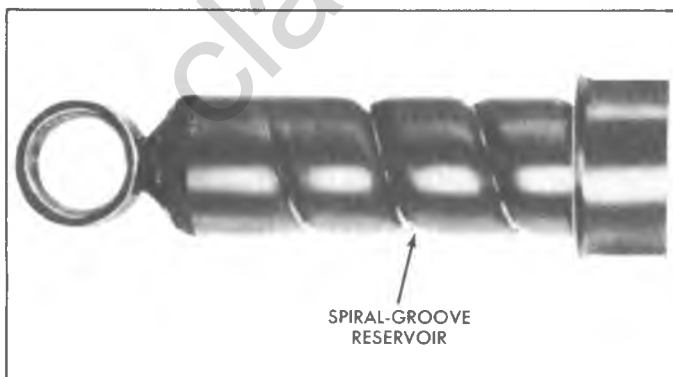

Fig. 8—Spiral-Groove Shock Absorber

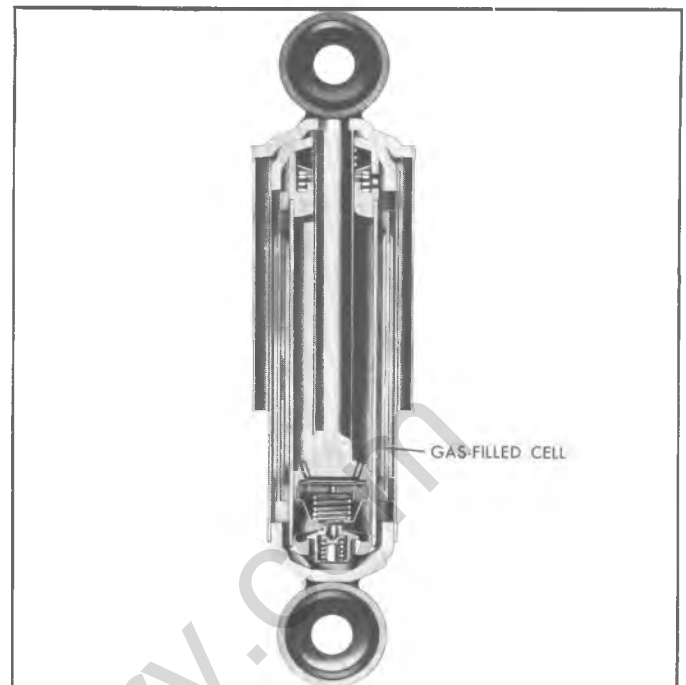

Fig. 9—Gas Filled Cell Shock Absorber

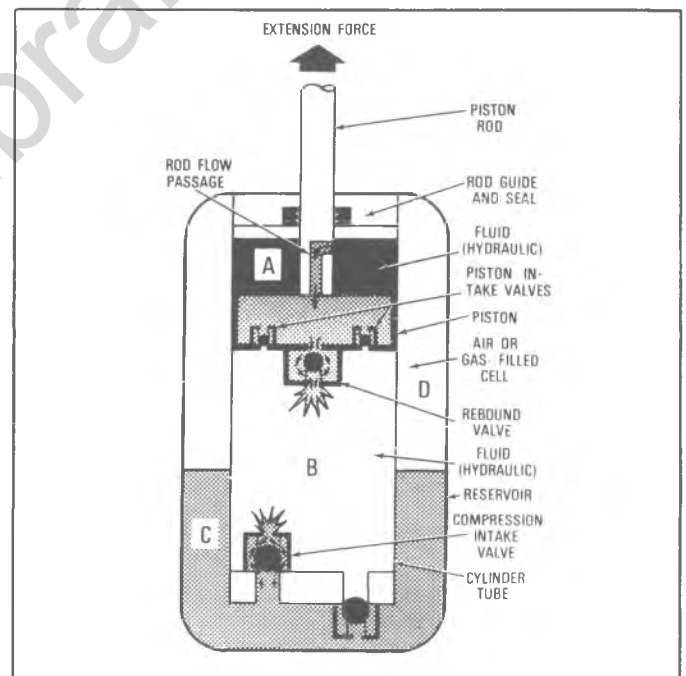

Fig. 10—Shock Absorber Rebound Schematic

example, body lean during a turn will result in low force in the shock absorber due to low piston velocity; while hitting a chuckhole at high speeds will generate high resistance forces.

The system of valves and orifices in a shock absorber which is referred to as the "valving," is composed of three distinct stages, which generate rebound and compression resistance levels (control) dependent upon

## 3-8 FRONT SUSPENSION

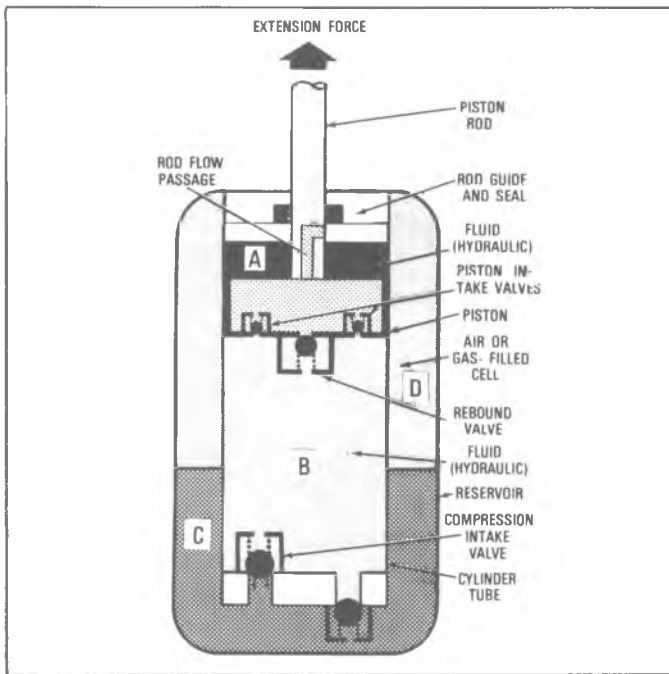

Fig. 11—Shock Absorber Rebound Cut Off Schematic

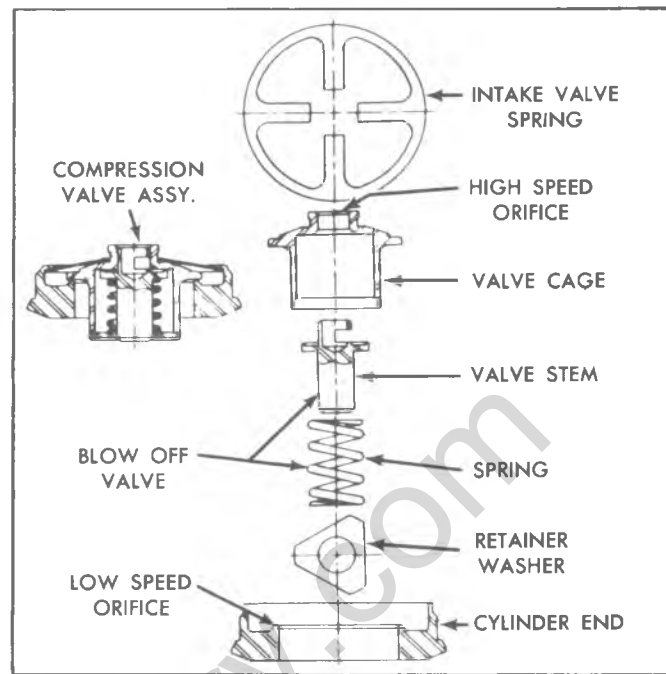

Fig. 12—Compression Valve Parts

shock absorber piston velocity. Figure 13 illustrates rebound valving, and Figure 12 illustrates compression valving. The three stages are described as follows.

### Low Speed Orifice (First Stage)

Two low speed orifices control fluid passage during slow body or wheel motions. The low speed orifice for rebound consists of slots in the orifice disc of the rebound valve, Figure 13, whereas the low speed orifice for compression consists of depressions in the cylinder end of the compression valve, Figure 12. This stage has its major effect in controlling low speed body movements. A very small, low speed orifice will cause a harsh ride in which every bump will be felt, similar to driving with over-inflated tires.

### Blow-Off Valve (Second Stage)

Two blow-off valves, Figures 12 and 13, control the fluid motion during intermediate body and/or wheel motion. Depending on direction of stroke, the spring-loaded

blow-off valve opens as soon as the pressure is great enough to unseat the valve, after which the low speed orifice ceases to have an appreciable effect. As the pressure of the fluid against the spring increases, the valve continues to open until it reaches its maximum lift.

### High Speed Orifice (Third Stage)

After the blow-off valve is completely open, further increases in control at even higher piston velocities is caused by restriction due to the high speed orifice. Basically, there are two high speed orifices. The high speed orifice on the rebound stroke is the holes in the inner ring of the piston, Fig. 13. The high speed orifice on the compression stroke is the hole in the compression valve cage, Figure 12, in combination with the slots in the outer ring of the piston. The high speed orifices are large enough not to affect flow through the low speed orifices or during the opening of the blow-off-valves, but will quickly increase the control under conditions such as wheel-hop, where high piston velocities are present.

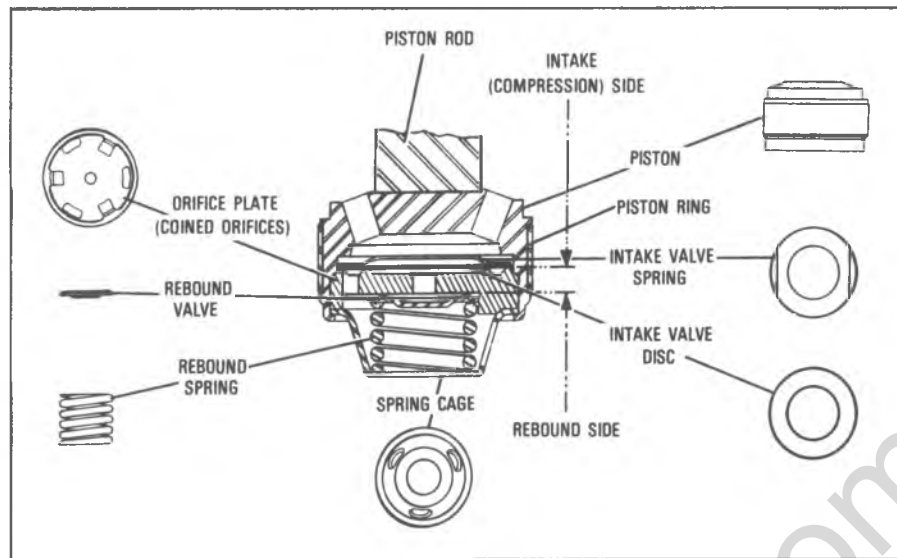

Fig. 13—Piston Valving Parts

## WHEEL ALIGNMENT

### FRONT SUSPENSION GEOMETRY (FIG. 14)

The term "front suspension geometry" refers to the angular relationships between the front wheels, the front suspension attaching parts and the ground. The angle of the knuckle (or steering axis inclination) away from the vertical, the pointing in or "toe-in" of the front wheels, the tilt of the front wheels from vertical (when viewed from the front of the vehicle) and the tilt of the suspension members from vertical (when viewed from the side of the vehicle), - all these are involved in front suspension geometry. The various factors that enter into front-end geometry are covered here each one under its own heading.

#### CASTER

Caster is the tilting of the front steering axis either

forward or backward from the vertical (when reviewed from the side of the vehicle). A backward tilt is said to be positive (+) and a forward tilt is said to be negative (-). On the short and long arm type suspension you cannot see a caster angle without a special instrument, but you can understand that if you look straight down from the top of the upper control arm to the ground you would find that the ball joints do not line up (fore and aft) when a caster angle other than 0° is present. If you had a positive caster angle the lower ball joint would be slightly ahead (toward the front of the vehicle) of the upper ball joint center line. In short then: caster is the forward or backward tilt of the steering axis as viewed from a side elevation. Caster is designed into the front axle assembly on all K series vehicles and is non-adjustable. See caster copy under ADJUSTMENTS.

## 3-10 FRONT SUSPENSION

### CAMBER

Camber is the tilting of the front wheels from the vertical when viewed from the front of the vehicle. When the wheels tilt outward at the top, the camber is said to be positive (+). When the wheels tilt inward at the top, the camber is said to be negative (-). The amount of tilt is measured in degrees from the vertical and this measurement is called the camber angle. Camber is designed into the front axle assembly of all K series vehicles and is non-adjustable. See camber copy under ADJUSTMENTS.

### TOE-IN

Toe-in is the turning in of the front wheels. The actual amount of toe-in is normally only a fraction of an inch. The purpose of a toe specification is to ensure parallel rolling of the front wheels. (Excessive toe-in or toe-out will cause tire wear) Toe-in also serves to offset the small deflections of the wheel support system which occurs when the vehicle is rolling forward. In other words, even when the wheels are set to toe-in slightly when the vehicle is standing still, they tend to roll parallel on the road when the vehicle is moving. See toe-in copy under ADJUSTMENTS.

### TOE-OUT ON TURNS (Fig. 15)

Toe-out on turns refers to the difference in angles between the front wheels and the vehicle frame during turns. Since the inner wheel turns a smaller radius than the outer wheel, when rounding a curve, it must be at a sharper angle with respect to the vehicle frame. That is, the inner wheel must toe-out more than the outside wheel toes-in. This condition is desirable because it allows the front wheels to turn in a concentric circle.

Note in fig. 15 that the right front wheel centerline (B) and the left front wheel centerline (C) intersect the centerline of the rear axle (A) at the same point (D). The 20° and 23° angles are not necessarily representative of any vehicle and are used here for theory only.

The angle of the steering arms is the determining factor of toe-out on turns. If either arm is bent, toe-out on turns will be affected.

This steering arm angle is not adjustable, so a bent arm must be replaced. Since it is unlikely that both arms will be bent, follow the procedure below to determine which, if either, arm is bent.

### Measurement

Measure the distance between the suspected bent arm and a stationary point on the brake backing plate or splash shield, comparing it with the same measurement on the other arm. The angle of the steering arms must be

the same for both arms. Toe-out on turns is not adjustable.

### STEERING AXIS INCLINATION (S.A.I.) FIG. 16

Steering axis inclination (formally called kingpin inclination on conventional suspensions) is the inward slant (at the top) of the steering knuckle from the vertical. This inclination tends to reduce road shock on the steering system by allowing the steering systems centerline to intersect the tire centerline near the point where the tire contacts the road. The inward slant or inclination of the steering knuckle tends to keep the wheels straight ahead. The reason for this is as follows: When the front wheels are straight ahead the steering knuckle spindles are practically horizontal. As the wheels are turned away from the straight ahead the outer ends of the spindle tries to lower or get closer to the ground. However, because the spindles are fixed in the hub assembly they cannot get closer, or lower, to the ground. So the spindles force the steering knuckles to raise the front of the vehicle.

After a turn is complete, and force applied to the steering wheel is released, the weight of the vehicle on the spindles tends to help the front wheels return to a straight ahead position. "Steering Axis Inclination" is a designed in angle and is non-adjustable.

### PRELIMINARY ADJUSTMENTS FIGS. 18-20

Before making any adjustment affecting caster, camber or toe-in, the following checks and inspections should be made to insure correctness of alignment readings and alignment adjustments:

1. Check all tires for proper inflation pressures and approximately the same tread wear.
2. Check front wheel bearings for looseness (.001-.008 end play is correct) and adjust if necessary.
3. Check for looseness of ball joints, tie rod ends and steering relay rods, if excessive looseness is noted, it must be corrected before adjusting.
4. Check for run-out of wheels and tires.
5. Check vehicle trim heights; if out of specifications and a correction is to be made, the correction must be made before adjusting caster, camber or toe-in.  
  
NOTE: Good judgment should be exercised before replacing a spring when vehicle trim height is somewhat out of limits ( $\pm 3/4''$ ).
6. Consideration must be given to excess loads, such as tool boxes. If this excess load is normally carried in the vehicle it should remain in the vehicle during alignment checks.
7. Consider the condition of the equipment being used to check alignment and follow the manufacturer's instructions.
8. Regardless of equipment used to check alignment the vehicle must be on a level surface both fore and aft and transversely.

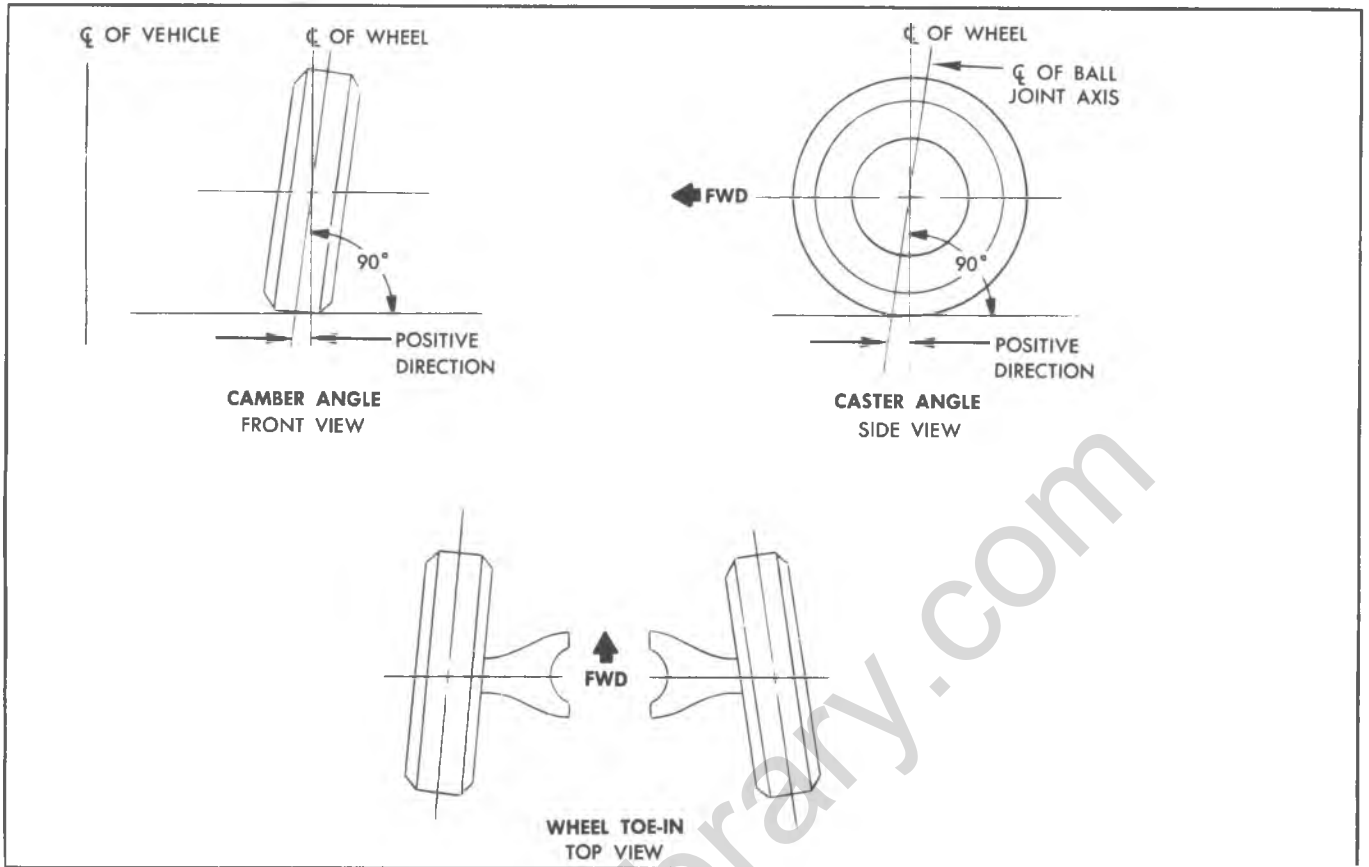

Fig. 14—Caster - Camber - Toe-in

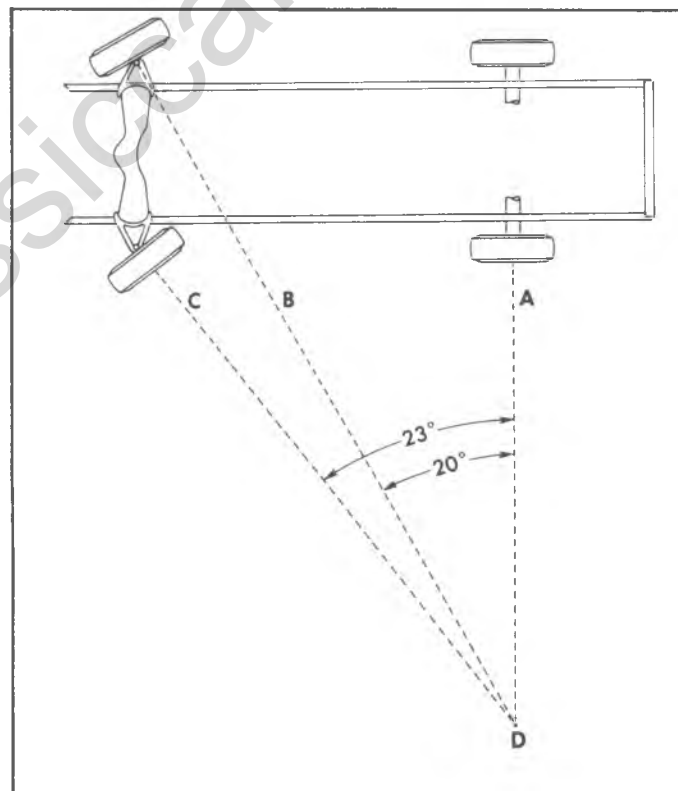

Fig. 15—Toe-out on Turns

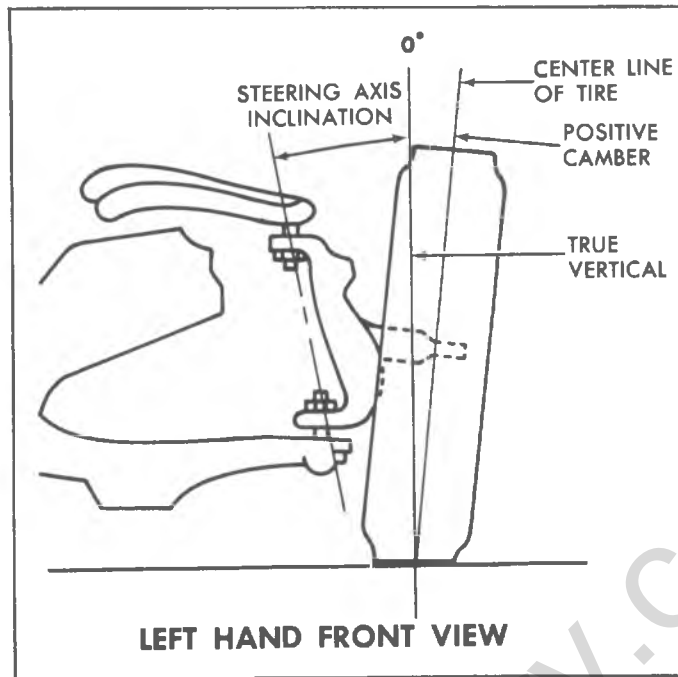

Fig. 16—Steering Axis Inclination

## MAINTENANCE AND ADJUSTMENTS

**CAUTION:** See *CAUTION* on page 1 of this section regarding the fasteners referred to in the maintenance and adjustment procedures below.

### WHEEL BEARINGS—CHECK ADJUSTMENT

**CAUTION:** Tapered roller bearings are used on all series vehicles and they have a slightly loose feel when properly adjusted. This differs from ball bearings which may be pre-loaded without adverse effect. A design feature of front wheel taper roller bearings is that they must *NEVER* be pre-loaded. Damage can result by the steady thrust on roller ends which comes from pre-loading.

### ADJUSTING FRONT WHEEL BEARINGS

The proper functioning of the front suspension cannot be maintained unless the front wheel **TAPER ROLLER BEARINGS** are correctly adjusted. Cones must be a slip fit on the spindle and the inside diameter of cones should be lubricated to insure that the cones will creep. Spindle nut must be a free-running fit on threads.

### CHECK ADJUSTMENT

1. Raise vehicle and support at front lower control arm.

2. Spin wheel to check for unusual noise or roughness.
3. If bearings are noisy, tight, or excessively loose, they should be cleaned, inspected and relubricated prior to adjustment. If it is necessary to inspect bearings, see Replacement of Wheel Bearings.

**NOTE:** To check for tight or loose bearings, grip the tire at the top and bottom and move the wheel assembly in and out on the spindle. Measure movement of hub assembly, if movement is less than .001" or greater than .005" adjust bearings per adjustment procedure.

On K Series a tolerance of .001" to .010" is allowed. For wheel bearing adjustment or replacement on K-Series see Wheel Bearing Adjustment in the four wheel drive description later in this section.

### ADJUSTMENT (FIG. 17)

1. Remove hub cap or wheel disc from wheel.
2. Remove dust cap from hub.
3. Remove cotter pin from spindle and spindle nut.
4. Tighten the spindle nut to 12 ft. lbs. while turning the wheel assembly forward by hand to fully seat the bearings. This will remove any grease or burrs which could cause excessive wheel bearing play later. (See Fig. 17).
5. Back off the nut to the "just loose" position.

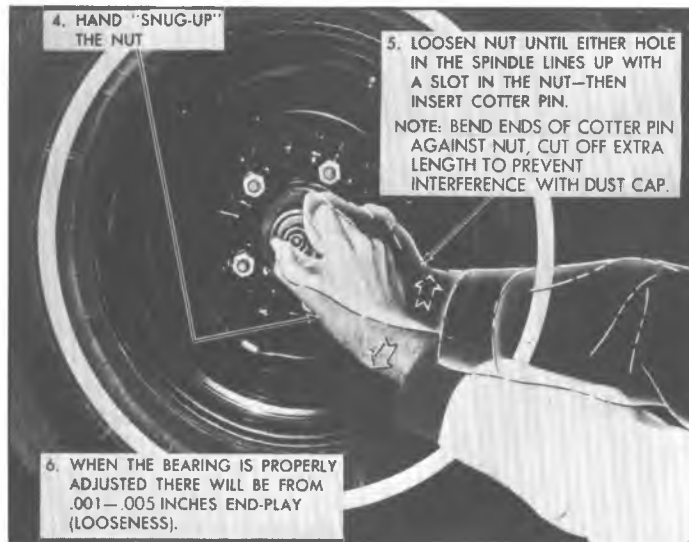

Fig. 17—Wheel Bearing Adjustment

6. Hand tighten the spindle nut. Loosen spindle nut until either hole in the spindle lines up with a slot in the nut. (Not more than 1/2 flat).
7. Install new cotter pin. Bend the ends of the cotter pin against nut, cut off extra length to ensure ends will not interfere with the dust cap.
8. Measure the looseness in the hub assembly. There will be from .001 to .005 inches end play when properly adjusted.
9. Install dust cap on hub.
10. Replace the wheel cover or hub cap.
11. Lower vehicle to floor.
12. Perform the same operation for each front wheel.

### FRONT ALIGNMENT (Fig. 18)

Satisfactory vehicle operation may occur over a wide range of front end wheel alignment settings. Nevertheless, should settings vary beyond certain tolerances, readjustment of alignment is advisable. The specifications stated in column 1 of the applicable vehicle chart in the specifications section of this manual should be used by owners, dealers and repairmen as guidelines in vehicle diagnosis either for repairs under the new vehicle warranty or for maintenance service at customer's request. These specifications provide an acceptable all-around operating range in that they prevent abnormal tire wear caused by wheel alignment.

Governmental Periodic Motor Vehicle Inspection programs usually include wheel alignment among items that are inspected. To provide useful information for such inspections, the specifications stated in column 2 of the aforesaid applicable chart are given and these are well within the range of safe vehicle operation.

In the event the actual settings are beyond the specifications set forth in column 1 or 2 (whichever is applicable), or whenever for other reasons the alignment is being reset, Chevrolet recommends that the specifica-

tions given in column 3 of the aforesaid applicable chart be used.

NOTE: A normal shim pack will leave at least two (2) threads of the bolt exposed beyond the nut. If two (2) threads cannot be obtained: Check for damaged control arms and related parts. Difference between front and rear shim packs must not exceed .30 inches. Front shim pack must be at least .24 inches.

### Caster (Fig. 19)

All caster specifications are given assuming a frame angle of zero. Therefore, it will be necessary to know the angle of the frame (whether "up" in rear or "down" in rear) before a corrected caster reading can be determined. Camber and toe can be read "as is" from the alignment equipment.

#### How to Determine Caster

1. With the vehicle on a level surface, determine the frame angle "B" in Fig. 19, using a bubble protractor or clinometer.
2. Draw yourself a graphic as in Fig. 19 that is representative of the frame angle (either "up" in rear or "down" in rear).
3. Determine the caster angle from the alignment equipment and draw a line that is representative of the caster reading.
4. To determine an "actual (corrected) caster reading" with various frame angles and caster readings one of the following rules applies.
  - a. A "DOWN IN REAR" frame angle must be **SUBTRACTED** from a **POSITIVE** caster reading.
  - b. An "UP IN REAR" frame angle must be **ADDED** to a **POSITIVE** caster reading.
  - c. A "DOWN IN REAR" frame angle must be

### 3-14 FRONT SUSPENSION

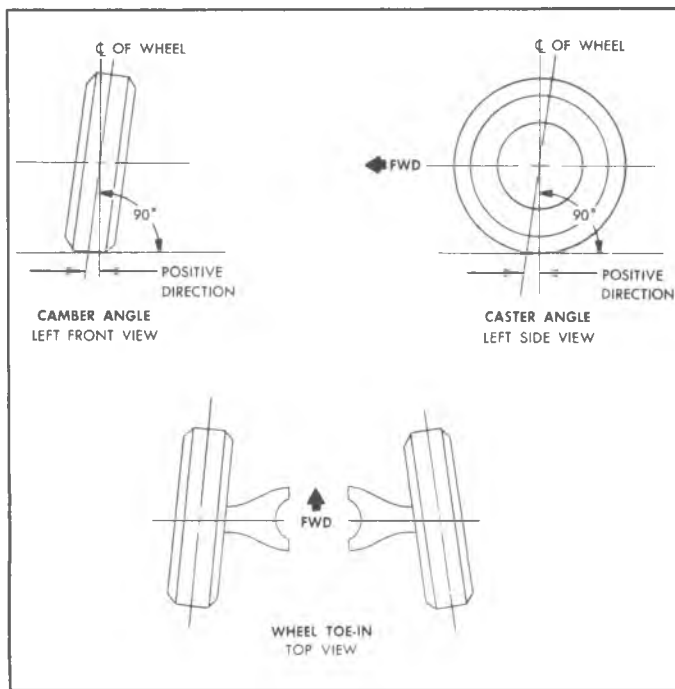

Fig. 18—Front Suspension Alignment

**ADDED** to a **NEGATIVE** caster reading.

- d. An **“UP IN REAR”** frame angle must be **SUBTRACTED** from a **NEGATIVE** caster reading.
5. Add or subtract as necessary to arrive at the corrected caster angle.
6. Measure dimension “A” (bump stop bracket to frame) and check the specifications for that dimension.
7. Correct the actual caster angle, as arrived at in Step 4, as necessary to keep within the specifications by adding or subtracting shims from the front or rear bolt on the upper control arm shaft (fig. 20).

#### Camber

1. Determine the camber angle from the alignment equipment.
2. Add or subtract shims from both the front and rear bolts to affect a change.

#### Toe-In

1. Determine the wheel toe-in from the alignment equipment.
2. Change the length of both tie rod sleeves to affect a toe change. See Section 9 for proper tie rod positioning and orientation, torque tie rod clamps to specifications.

Vehicles within these tolerances from the mean specification are safe and not hazardous with respect to alignment effects on operation and handling. Settings outside these limits are not necessarily unsafe, however, customer dissatisfaction, due to steering pull or tire wear may occur or the vehicle may be in a damaged condition.

#### DEFINITIONS

##### Service Checking

Values within these limits should provide a high level of customer satisfaction and should not require resetting.

##### Service Reset

Values that the vehicle should be set within if it is observed out of the service checking tolerance, or if it is being aligned due to replacement of components, or for any other reasons.

##### Vehicle Inspection Tolerances

For government inspection station usage.

##### Toe-In Changing Fig. 21

Toe-in can be increased or decreased by changing the length of the tie rods. A threaded sleeve is provided for this purpose.

When the tie rods are mounted ahead of the steering knuckle they must be decreased in length in order to increase toe-in. When the tie rods are mounted behind the steering knuckle they must be lengthened in order to increase toe-in.

See Section 9 for proper tie rod clamp orientation and positioning.



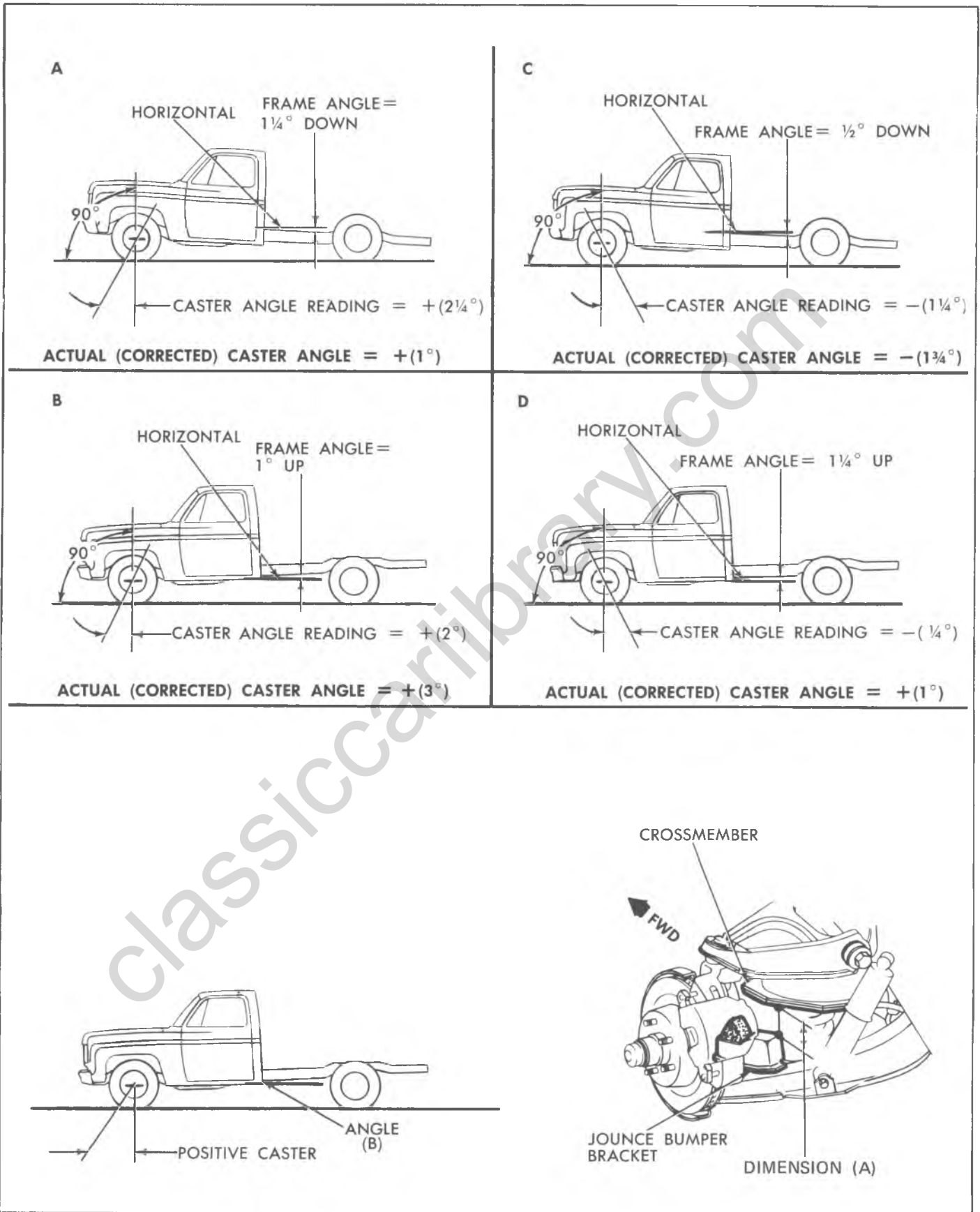

Fig. 19—Determining Caster - Typical (C Series Shown)

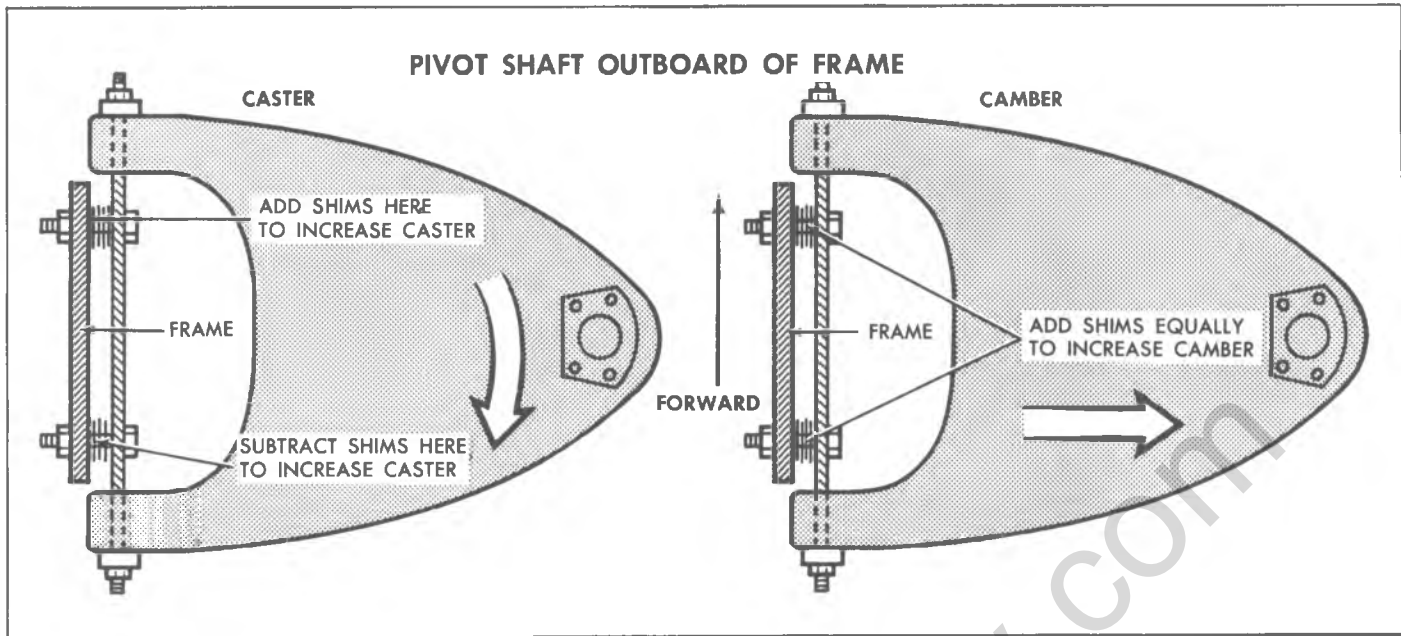

Fig. 20—Caster - Camber Adjustment

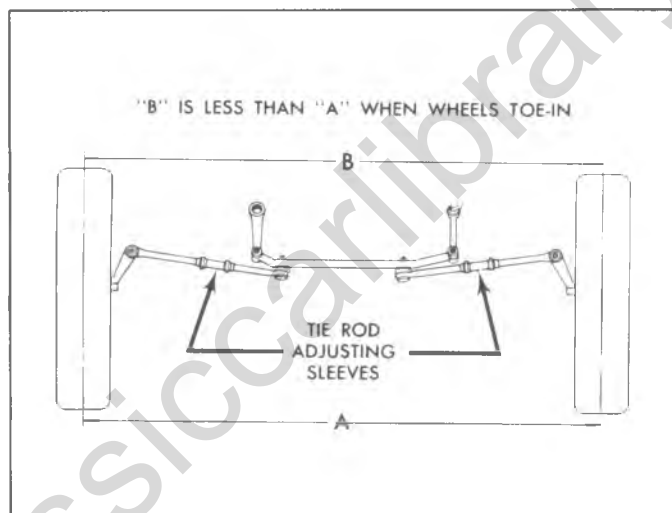

Fig. 21—Toe-in Adjustment

## COMPONENT PARTS REPLACEMENT

### WHEEL HUBS, BEARINGS (Fig. 22)

#### Removal C, G and P Series

1. Raise vehicle on hoist and remove wheel and tire assembly. Remove dust cap from end of hub and withdraw cotter pin.
2. Remove the brake caliper and hang by wire to the suspension.

**CAUTION:** Do not allow the caliper assembly to hang by the brake flex line.

3. Remove hub and disc assembly.
4. Remove outer bearing from hub. The inner bearing will remain in the hub and may be removed by prying out the inner grease seal.
5. Wash all parts in cleaning solvent.

#### Inspection

1. Check all bearings for cracked bearing cages, worn or pitted rollers.
2. Check bearing races for cracks or scoring, check

brake discs for out-of-round or scored conditions and check bearing outer races for looseness in hubs.

### Repairs

#### Replacement of Bearing Cups

If necessary to replace an outer race, drive out old race from the hub with a brass drift inserted behind race in notches in hub. Install new race by driving it into hub with the proper race installer J-8457, J-8458, J-8849 or J-9276-2. Remove and install the inner race in the same manner.

**CAUTION:** Use care when installing new race to start it squarely into hub, to avoid distortion and possible cracking.

Thoroughly lubricate bearing assemblies with new high melting point wheel-bearing lubricant. Remove any excess lubricant.

**NOTE:** Be sure bearing parts have been thoroughly cleaned and air-dried.

#### Wheel Stud Replacement (Fig. 22)

**NOTE:** Use a piece of water pipe or other similar tool to support the hub while pressing a wheel stud either in or out.

#### Installation

**CAUTION:** See CAUTION on page 1 of this section regarding the fasteners referred to in steps 3, 4 and 5.

1. Pack inner and outer wheel bearings with recommended grease (see Section 0).
2. Place inner bearing in hub and install new seal assembly, tapping into place with soft hammer.
3. Position hub and disc on spindle and install outer bearing, pressing it firmly into position in hub. Install hub washer and finger tighten nut.
4. Install brake caliper see section 5.
5. Install wheel and tire, and adjust wheel bearings as outlined under Wheel Bearings—Adjust, then lower vehicle to floor.

## SHOCK ABSORBER

#### Removal (Figs. 23 and 24)

1. Raise vehicle on hoist.
2. Remove nuts and eye bolts securing upper and lower shock absorber eyes.
3. Withdraw shock absorber and inspect rubber eye bushings. If defective, replace shock absorber assembly.

#### Installation

Place shock absorber into position over mounting bolts or into mounting brackets. Install eye bolts and nuts and torque as shown in Specifications Section. Lower vehicle to floor.

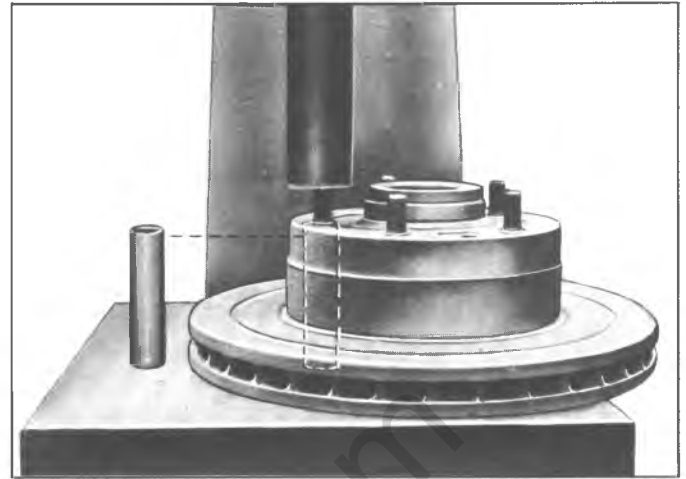

Fig. 22—Pressing Hub Bolt

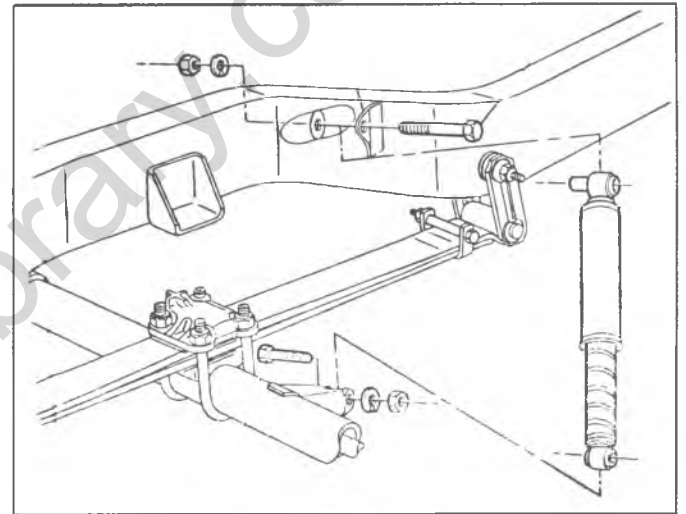

Fig. 23—Shock Absorber - K Series

## STABILIZER BAR—TYPICAL

#### Removal (Fig. 25)

1. Raise vehicle on hoist and remove nuts and bolts attaching stabilizer brackets and bushings at frame location.
2. Remove brackets and bushings at lower control arms (spring anchor plates on K series) and remove stabilizer from vehicle.

#### Inspection

Inspect rubber bushings for excessive wear or aging—replace where necessary. Use rubber lubricant when installing bushings over stabilizer bar.

#### Installation

**CAUTION:** See CAUTION on page 1 of this section regarding the fasteners referred to in step 2.

### 3-18 FRONT SUSPENSION

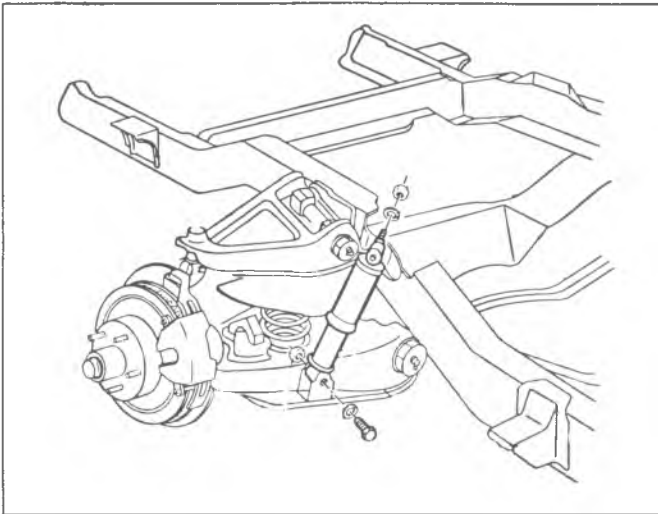

Fig. 24—Shock Absorber - C, P and G Typical

NOTE: Slit in bar to frame bushings should be facing forward.

1. Place stabilizer in position on frame and install frame brackets over bushings. Install nuts and bolts loosely.
2. Install brackets over bushings at lower control arm location. Be sure brackets are positioned properly over bushings. Torque all nuts and bolts to specifications.
3. Lower vehicle to floor.

### COIL SPRING

#### Removal (Fig. 27)

1. Place vehicle on hoist and place jack stands under frame, allowing control arms to hang free.
2. Disconnect shock absorber at lower end and move aside. Disconnect the stabilizer bar attachments to the lower control arm.

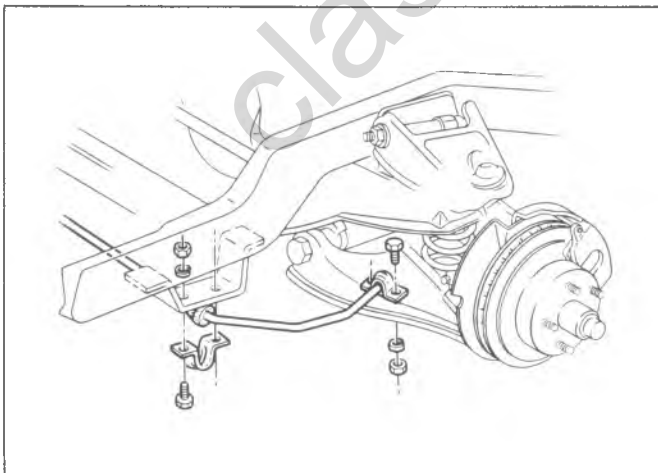

Fig. 25—Stabilizer Bar - C, P and G Typical

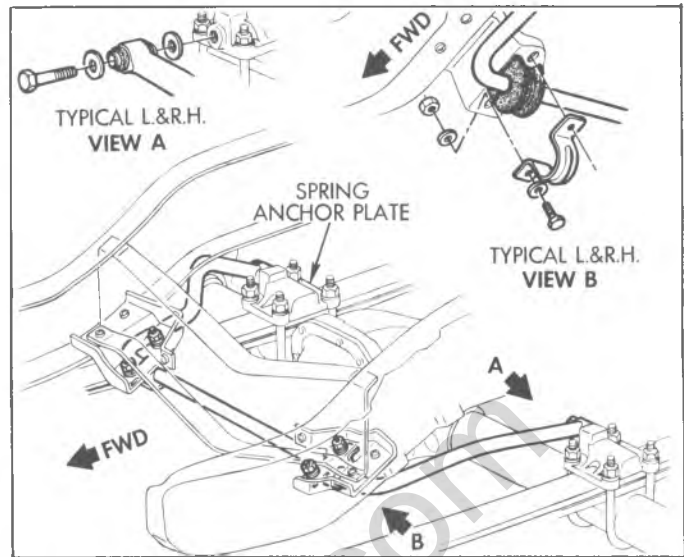

Fig. 26—Stabilizer Bar K-Typical



Fig. 27—Removing Coil Spring with Tool J-23028

3. Bolt Tool J-23028 to a suitable jack.
4. Place tool under cross-shaft so that the cross-shaft seats in the grooves of the tool. As a safety precaution install and secure a chain through the spring and lower control arm.
5. Raise the jack to remove tension on the lower control arm cross-shaft and remove the two "U" bolts securing the cross-shaft to crossmember.

**WARNING:** The cross-shaft and lower control arm keeps the coil spring compressed. Use care when lowering.

6. Lower control arm by slowly releasing the jack until spring can be removed. Be sure all compression is relieved from spring.
7. Remove spring.

**Installation**

**CAUTION:** See *CAUTION* on page 1 of this section regarding the fasteners referred to steps 3 and 4.

1. Properly position spring on the control arm, and lift control arm using jack and tool J-23028.
2. Position control arm cross-shaft to crossmember and install "U" bolts and attaching nuts. Make certain front indexing hole in cross-shaft is lined up with crossmember attaching saddle stud.
3. Torque nut to specifications.
4. Install shock absorber to lower control arm and install stabilizer bar.
5. Remove tool J-23028 and safety chain.
6. Lower vehicle to floor.

**LEAF SPRING AND BUSHINGS K SERIES****Removal**

1. Raise vehicle on hoist.
2. Place adjustable lifting device under axle.
3. Position axle so that all tension is relieved from spring.
4. Remove shackle upper retaining bolt.
5. Remove front spring eye bolt.
6. Remove spring-to-axle u-bolt nuts and remove spring, lower plate and spring pads.
7. Remove shackle to spring bolt and remove bushings and shackle.

**Bushing Replacement**

1. Place spring on press and press out bushing using a suitable rod, pipe, or tool.
2. Press in new bushing; assure that tool presses on steel outer shell of bushing. Install until bushing protrudes an equal amount on each side of spring.

**Spring Inserts (Liners) or Leaf Replacement**

1. Place spring in vise and remove clips.
2. Remove center bolt. Open vise slowly, allowing spring to expand.
3. Wire brush, clean, and inspect for broken leaves.
4. Replace leaf or liners.

**Installation**

**CAUTION:** See *CAUTION* note on page one of this section regarding the fasteners referred to in steps 5 and 6.

1. Install spring shackle bushings into spring and attach shackle. Do not tighten bolt.
2. Position spring upper cushion on spring.
3. Insert front of spring into frame and install bolt. Do not tighten.

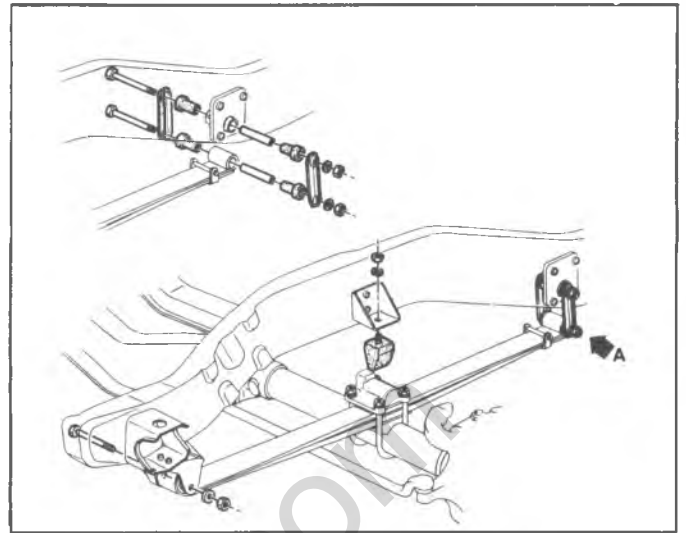

Fig. 28—Leaf Spring Assembly K-Series

4. Install shackle bushings into frame and attach rear shackle. Do not tighten bolt.
5. Install lower spring pad and spring retainer plate. Torque bolts to specifications.
6. Torque front and rear spring eye and shackle bolts to specifications.
7. Remove stands and lower vehicle to floor.

**UPPER CONTROL ARM INNER PIVOT SHAFT****AND/OR BUSHING REPLACEMENT****C20-30, G30 and P10-30 (Steel Bushings)****Pivot Shaft Removal**

1. Raise vehicle and remove tire and wheel assembly.
2. Support the lower control arm with a floor jack.  
**NOTE:** Position jack under the ball joint assembly or as near as possible and still have good support.
3. Loosen the upper control arm shaft end nuts before loosening the shaft to frame attaching nuts.
4. Loosen the shaft to frame nuts and remove the caster and camber shims.

**NOTE:** Tape the shims together as they are removed and mark for position.

5. Remove the pivot shaft to frame nuts but do not allow the arm to swing too far away from the frame.

**NOTE:** Use a safety chain to retain the arm in a close relationship to the frame.

6. Remove the shaft end nuts and remove shaft from arm.

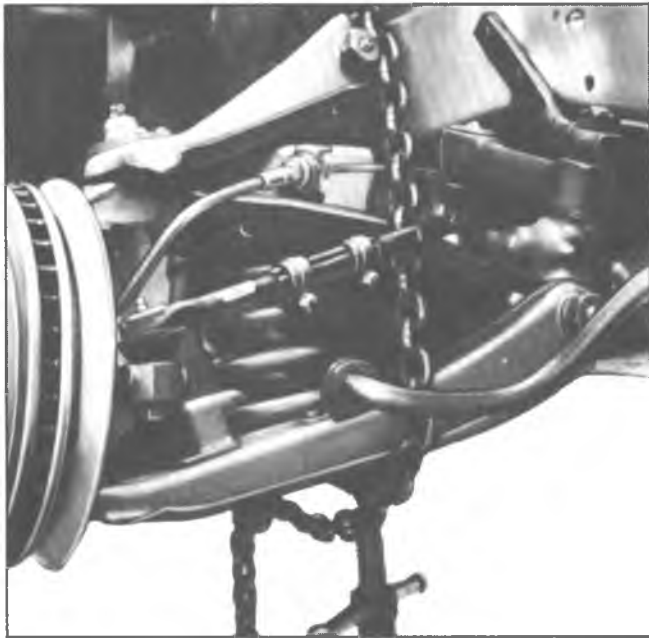

Fig. 29—Removing Inner Pivot Shaft

### Bushing Replacement (Steel Bushings)

1. Remove grease fittings from bushing outer ends and unscrew bushings from control arm and shaft.
2. Slide new seal on each end of shaft and insert shaft into control arm.
3. Start new bushings on shaft and into control arm. Adjust shaft until it is centered in control arm, then turn bushings in and torque to specifications. Figure 30 shows correct final positioning of shaft. Check shaft for free rotation and install grease fittings.

### Installation

**CAUTION:** See *CAUTION* on page 1 of this section regarding the fasteners referred to in steps 3, 5 and 6.

**NOTE:** When installing the upper control arm be sure to properly position the special aligning washers to the pivot shaft with convex and concave sides together.

1. Install the shaft to the control arm and install end nuts. Do not torque nuts at this time.
2. Position cross shaft to frame bolts and start cross shaft nuts.
3. Torque the shaft end nuts. See Fig. 30 for proper spacing.

**NOTE:** The shaft should rotate by hand after the nuts are torqued.

4. Install caster and camber shim in their appropriate places.
5. Torque the cross-shaft to frame nuts.
6. Remove the safety chain and install the tire.
7. Lower vehicle to the floor.

## LOWER CONTROL ARM INNER PIVOT SHAFT AND/OR BUSHING REPLACEMENT C20-30, G30, P10-30 (Steel Bushings)

### Lower—Removal (Fig. 29)

1. Raise vehicle and support the frame so that control arms hang free.
2. Position an adjustable floor jack under the control arm inboard of spring and into depression in lower arm.
3. Install a chain over upper arm (Fig. 29). Inboard of stabilizer and outboard of shock absorber as a safety measure.
4. Disconnect shock absorber at lower control arm.
5. Loosen shaft end nuts.
6. Remove "U" bolts.
7. Lower jack just enough to get at shaft.
8. Remove shaft end nuts and remove shaft.

### Bushing Replacement (Steel Bushings)

1. Remove grease fittings from ends of bushings and unscrew bushings from shaft and control arm. Remove shaft and seals.
2. Slide new seal on each end of shaft and insert shaft into control arm.
3. Start new bushings on shaft and into control arm. Adjust shaft until it is centered in control arm, then turn bushings in and torque to specifications. Check shaft for free rotation. Figure 31 shows correct final positioning of shaft.

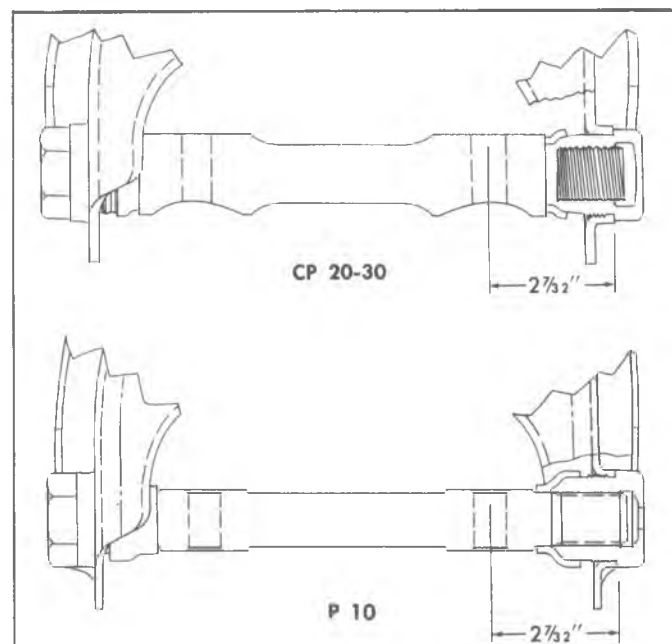

Fig. 30—Positioning Upper Control Arm Shaft (Steel Bushings)

**Installation**

**CAUTION:** See *CAUTION* on page 1 of this section regarding the fasteners referred to in steps 4 and 5.

1. Install shaft to control arm and install end nuts. Do not torque nuts at this time.
2. Raise jack and position shaft into crossmember saddle. Be sure to index hole in shaft to mate with bolt head in saddle.
3. Install "U" bolts. Do not torque nuts at this time.
4. Torque cross-shaft end nuts.

**NOTE:** The shaft should rotate by hand after the nuts are torqued.

5. Torque "U" bolt nuts.
6. Remove safety chain.
7. Lower vehicle to floor.

**UPPER CONTROL ARM ASSEMBLY**

**All Removal**

1. Raise vehicle on hoist, remove wheel and tire assembly and support lower control arm assembly with adjustable jackstand.
2. Remove cotter pin from upper control arm ball stud and loosen stud nut one turn.
3. Loosen upper control arm ball stud in steering knuckle, using Tool J-23742 position as shown in Figure 34. Remove the nut from the ball stud and raise upper arm to clear steering knuckle.

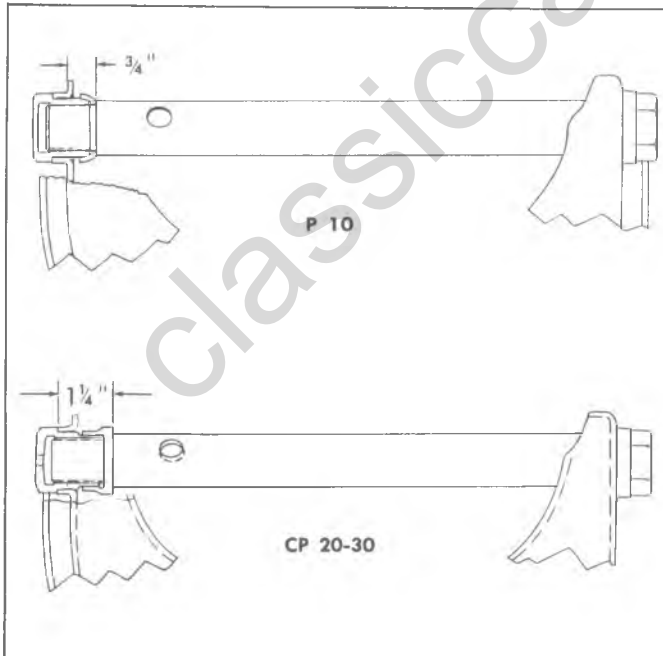

Fig. 31—Positioning Lower Control Arm Shaft (Steel Bushings)

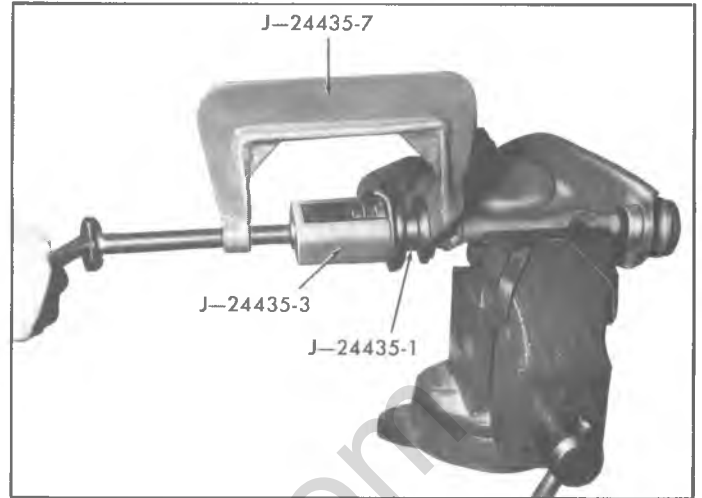

Fig. 32A—Upper Control Arm Rubber Bushing Removal

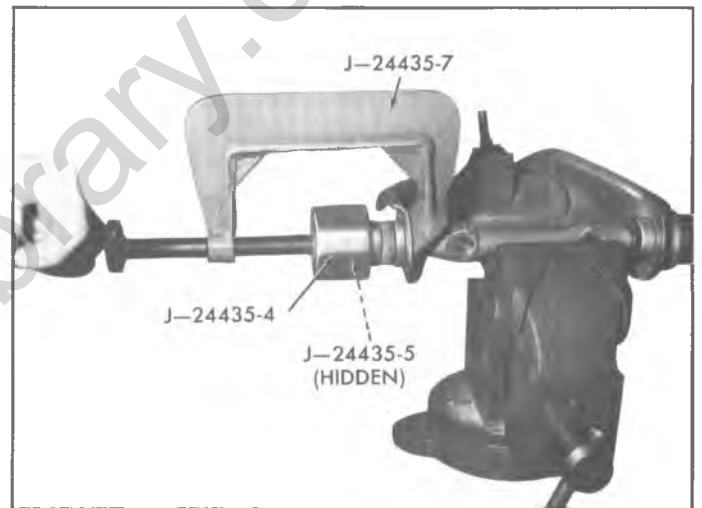

Fig. 32B—Upper Control Arm Rubber Bushing Installation

**NOTE:** It is necessary to remove the brake caliper assembly and wire it to the frame to gain clearance for tool J-23742. See section 5 for proper clearance.

4. Remove nuts securing control arm shaft to frame. Withdraw control arm assembly.

**NOTE:** Tape shims together and tag for proper relocation when control arm is reinstalled.

**Upper Control Arm Inner Pivot Shaft and/or Bushing Replacement**

**C10, G10-20 (Rubber Bushings)**

**Removal (Fig. 32A)**

1. Remove the upper control arm using the preceding procedure and mount the control arm in a vise.

## 3-22 FRONT SUSPENSION

2. Install remover J-24435-1, receiver J-24435-3 and "C" clamps J-24435-7 as shown in Figure 32A.
3. Tighten the clamp to draw out the old bushing. Discard old bushing.
4. The pivot shaft may now be removed from the control arm assembly.
5. Reposition the control arm in the vise and repeat the removal procedure on the remaining bushing.

### Bushing Installation

1. Again using "C" clamp J-24435-7 and installers J-24435-4 (outer) and J-24435-5 (inner) tighten clamp to install bushing onto control arm.
2. Install pivot shaft into inside diameter of first installed bushing.
3. Install remaining bushing as shown in figure 32B and described in step 1.
4. Remove tools and install control arm on vehicle following procedure described below. Torque all fasteners to proper specifications.

### Upper Control Arm Installation

**CAUTION:** See *CAUTION* on page 1 of this section regarding the fasteners referred to in steps 1, 2 and 3.

**NOTE:** When installing the upper control arm be sure to position the special aligning washers to the pivot shaft with concave and convex sides together.

1. Place control arm in position on bracket and install nuts. Before tightening nuts, insert caster and camber shims in the same order as when removed. Torque the nuts to specifications.

**NOTE:** A normal shim pack will leave at least two (2) threads of the bolt exposed beyond the nut. If two (2) threads cannot be obtained: Check for damaged control arms and related parts. Difference between front and rear shim packs must not exceed .30 inches. Front shim pack must be at least .24 inches.

**NOTE:** Always tighten the thinner shim packs' nut first for improved shaft to frame clamping force and torque retention.

2. Insert ball joint stud into steering knuckle and install nut. Torque stud nut to specifications and install cotter pin.
3. Install brake caliper assembly if removed (see section 5).
4. Remove adjustable support from under lower control arm. Install wheel and tire assembly.
5. Lower the vehicle to the floor.

## LOWER CONTROL ARM ASSEMBLY

### Removal

1. Raise vehicle on hoist and remove spring as outlined under spring removal.

**NOTE:** Support the inboard end of the control arm after spring removal.

2. Remove cotter pin from lower ball stud and loosen stud nut one turn.
3. Install Ball Stud Remover J-23742, position large cup end of the tool over the upper ball stud nut and piloting the threaded end of tool on end of the lower ball stud. Extend bolt from Tool J-23742 to loosen lower ball stud in steering knuckle. When stud is loosened, remove tool and nut from lower stud.

**NOTE:** It is necessary to remove the brake caliper assembly and wire it to the frame to gain clearance for tool J-23742. See section 5 for proper procedure.

4. Remove the lower control arm.

### Lower Control Arm Inner Pivot Shaft and/or Bushing Replacement-On Vehicle

#### C10, G10-20 (Rubber Bushings)

#### Removal (figs. 33A and 33B)

**NOTE:** If just bushings or pivot shaft are to be replaced the lower control arm does not have to be removed from the vehicle.

1. Raise vehicle on hoist and support the frame so that the control arms hang free.
2. Position an adjustable floor jack under the lower control arm inboard of spring and into depression of control arm.

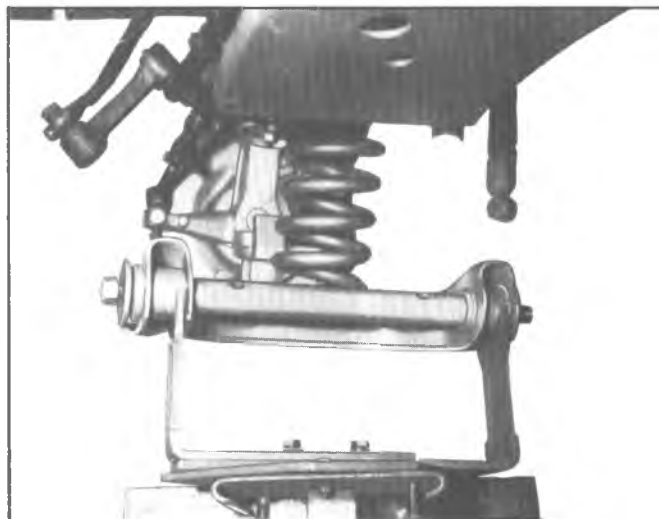

Fig. 33A—Lowering Control Arm for Bushing Replacement



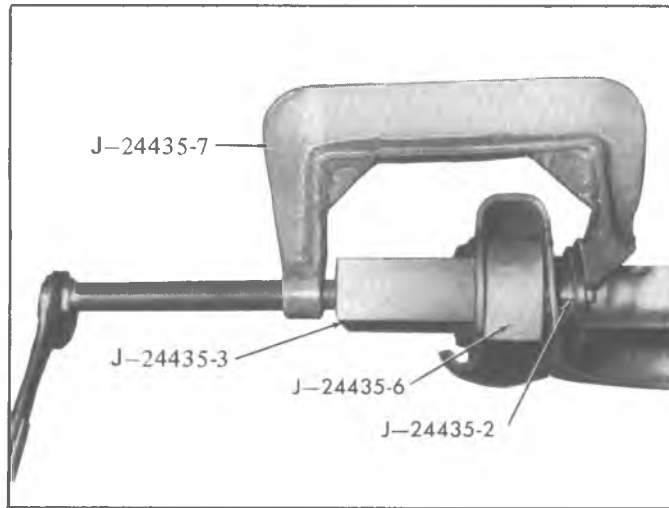

Fig. 33B—Lower Control Arm Rubber Bushing Removal

3. Install a chain over the upper arm inboard of the stabilizer and outboard of shock absorber as a safety measure.
4. Disconnect shock and stabilizer bar attachments at lower control arm.
5. Loosen shaft end nuts.
6. Remove "U" bolts that retain the inboard end of the lower control arm.
7. Lower jack SLOWLY to release spring compression (fig. 33A) and gain clearance to remove bushings.

**WARNING:** Be sure all compression is released from coil springs.

8. Bushings may now be replaced. Install "C" clamps J-24435-7 and receiver J-24435-3 with remover J-24435-2 and spacer J-24435-6 as shown in figure 33B.
9. Remove the stakes on the front bushing using tool J-22717 or equivalent tool.
10. Tighten the "C" clamp to remove the bushing.
11. Remove tools and discard old bushing.
12. Pivot shaft may now be removed if necessary.
13. Remove second bushing (leave pivot shaft in to pilot tool) by the same method as in steps 8-12.

#### Bushing Installation (fig. 33C)

**CAUTION:** See CAUTION on page 1 of this section regarding the fasteners referred to in step 5.

1. Install new bushings as shown in figure 33C using spacer J-24435-6, installer J-24435-4 and "C" clamp J-24435-7.
2. Turn clamp in until bushing seats firmly.

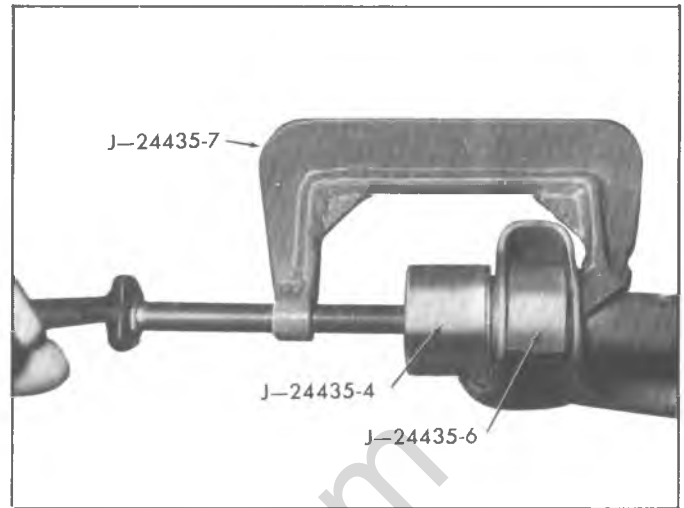

Fig. 33C—Lower Control Arm Rubber Bushing Installation

**CAUTION:** Be sure spacer J-24435-6 is in position as shown in figure 33C to avoid collapsing control arm during assembly.

3. Install one bushing then insert the pivot shaft and install second bushing.
4. Stake front bushing at least in two places when installed.
5. Install the lower control arm to the vehicle as described under "Lower Control Arm - Installation", being sure to torque all fasteners to the proper specification.

#### Lower Control Arm Installation

**CAUTION:** See CAUTION on page 1 of this section regarding the fasteners referred to in steps 2 and 3.

1. Install lower ball stud through steering knuckle and tighten nut.
2. Install spring and control arm as outlined under spring installation.
3. Torque lower control arm ball stud to specifications and install cotter pin.
4. Install brake caliper assembly if removed (see section 5).
5. Lower the vehicle to the floor.

## BALL JOINT SERVICE—ON VEHICLE

### Ball Joint—Inspection

The upper ball stud is spring loaded in its socket. This minimizes looseness at this point and compensates for normal wear, if the upper stud has any perceptible lateral shake, or if it can be twisted in its socket with the fingers, the upper ball joint should be replaced.

### 3-24 FRONT SUSPENSION

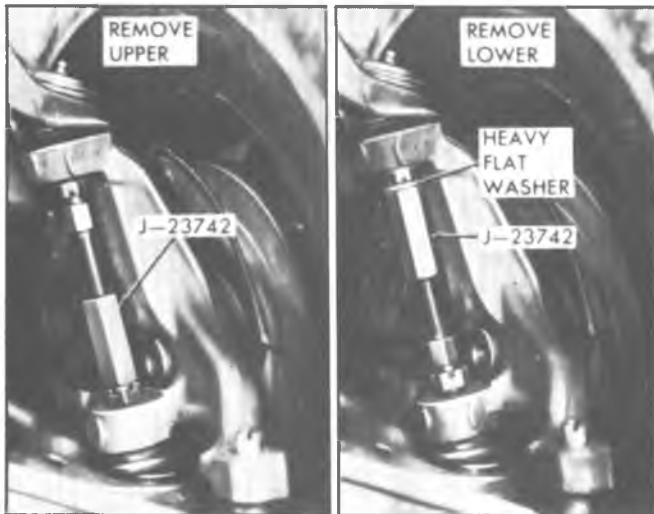

Fig. 34—Disconnecting Ball Joints—Typical

#### Upper—Removal

1. Raise vehicle on hoist. If a frame hoist is used, it will be necessary to support the lower control arm with a floor jack.
2. Remove cotter pin from upper ball stud and loosen stud nut (two turns) but do not remove nut.
3. Install J-23742 between the ball studs as shown in Figure 34.

**NOTE:** It is necessary to remove the brake caliper assembly and wire it to the frame to gain clearance for tool J-23742. See section 5 for the proper procedure.

**CAUTION:** Before proceeding with Step 4, be sure lower control arm is supported as pointed out in Step 1.

4. Extend bolt from Tool J-23742 to loosen ball stud in steering knuckle. When stud is loose, remove tool and stud nut.
5. Center punch rivet heads and drill out rivets.
6. Remove the ball joint assembly.

#### Installation

**CAUTION:** See CAUTION on page 1 of this section regarding the fasteners referred to in steps 1, 3 and 6.

1. Install new service ball joint, using bolts and nuts supplied with joint, to upper arm. Torque nuts to 45 ft. lbs.
2. Mate ball stud to steering knuckle and install stud nut.
3. Torque the ball stud nut as follows:
  - A. 10 Series 40—60 ft. lbs. plus additional torque to align cotter pin not to exceed 90 ft. lbs. Never back off to align cotter pin.
  - B. 20—30 Series 80—100 ft. lbs. plus additional

torque to align cotter pin not to exceed 130 ft. lbs. Never back off to align cotter pin.

4. Install new cotter pin.
5. Install lube fitting and lube new joint.
6. Install brake caliper assembly if removed (see section 5).
7. Install tire and wheel assembly.
8. Lower the vehicle to the floor.

#### Ball Joint—Inspection

##### Lower

Lower ball joints are a loose fit when not connected to the steering knuckle. Wear may be checked without disassembling the ball stud, as follows:

1. Support weight of control arms at wheel hub and drum.
2. Accurately measure distance between tip of ball stud and tip of grease fitting below ball joint.
3. Move support to control arm to allow wheel hub and drum to hang free. Measure distance as in Step 2. If the difference in measurements exceeds .094" (3/32") for all models, ball joint is worn and should be replaced (fig. 35).

##### Lower—Removal

1. Raise vehicle on a hoist. If a frame hoist is used it will be necessary to support the lower control arm with a floor stand.
2. Remove the tire and wheel assembly.
3. Remove the lower stud cotter pin and loosen (two turns) but do not remove the stud nut.
4. Install J-23742 between the ball studs as shown in Figure 34.

**NOTE:** It is necessary to remove the brake



Fig. 35—Checking Lower Ball Joint

caliper assembly and wire it to the frame to gain clearance for tool J-23742. See section 5 for proper procedure.

**CAUTION:** Before proceeding with Step 5, be sure lower control arm is supported as pointed out in Step 1.

5. Extend bolt from Tool J-23742 to loosen ball stud in steering knuckle. When stud is loosened, remove tool and ball stud nut.
6. Pull the brake disc and knuckle assembly up off the ball stud and support the upper arm with a block of wood so that assembly is out of working area.

**CAUTION:** Do not put stress on the brake line flex hose.

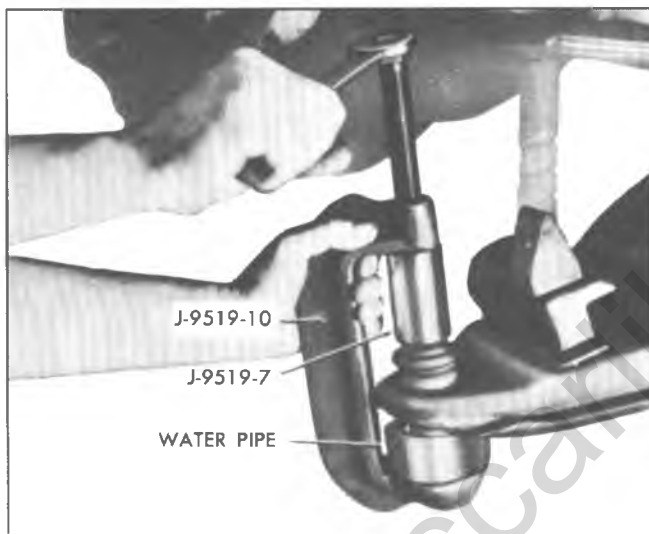

Fig. 36—Ball Joint Removal

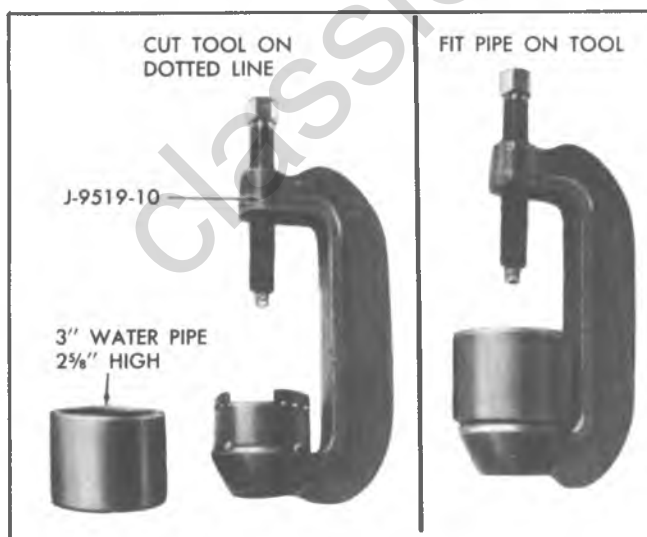

Fig. 37—Alteration to Tool J-9519-10

7. Install Tools J-9519-10 and J-9519-7 as shown in Fig. 36.

**NOTE:** It will be necessary to alter Tool J-9519-10 as illustrated in Fig. 37 and install a 3" I.D. pipe as shown if working on a 20 or 30 series vehicle.

8. Turn hex head screw until ball joint is free of control arm.
9. Remove tools and the ball joint.

#### Installation (Fig. 38)

**CAUTION:** See CAUTION on page 1 of this section regarding the fasteners referred to in steps 4, 5 and 7.

1. Start the new ball joint into the control arm and install J-9519 and J-9519-9 as shown.

**NOTE:** Position bleed vent in rubber boot facing inward.

2. Turn hex head screw until ball joint is seated in control arm.
3. Lower the upper arm and mate the steering knuckle to the lower ball stud.
4. Install brake caliper assembly if removed (see Section 5).
5. Install ball stud nut and torque as follows. All Series, 80–100 ft. lbs. plus additional torque to align cotter pin hole not to exceed 130 ft. lbs. maximum. Never back off to align cotter pin.
6. Install a lube fitting and lube the joint.
7. Install tire and wheel assembly and lower vehicle to floor.

#### STEERING KNUCKLE

It is recommended that vehicle be raised and supported as on a twin-post hoist so that the front coil spring

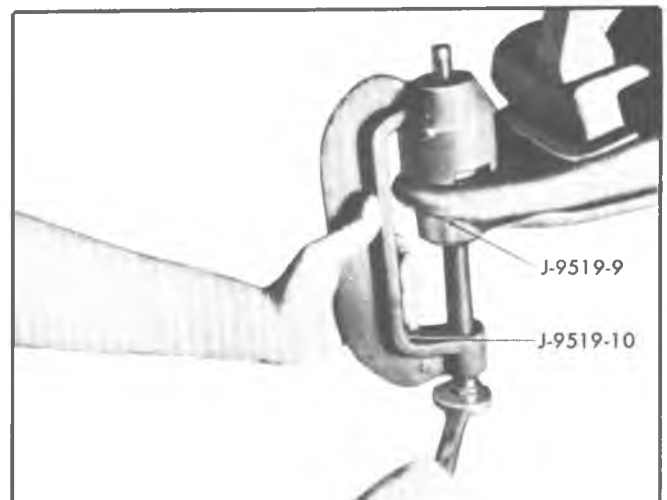

Fig. 38—Installing Ball Joint

### 3-26 FRONT SUSPENSION

remains compressed, yet the wheel and steering knuckle assembly remain accessible. If a frame hoist is used, support lower control arm with an adjustable jackstand to safely retain spring in its curb height position.

#### Removal

1. Raise vehicle on hoist and support lower control arm as noted above.
2. Remove wheel and tire assembly.
3. Remove caliper as outlined under "Front Wheel Hub - Removal".
4. Remove disc splash shield bolts securing the shield to the steering knuckle. Remove Shield.
5. Refer to Section 9 – Steering Linkage – Tie Rod, for service removal operations.
6. Remove upper and lower ball stud cotter pins and loosen ball stud nuts. Free steering knuckle from ball studs by installing Special Tool J-23742. Remove ball stud nuts and withdraw steering knuckle.

#### Installation

**CAUTION:** See CAUTION on page 1 of this section regarding the fasteners referred to in steps 2, 3, 4 and 5.

1. Place steering knuckle in position and insert upper and lower ball studs into knuckle bosses.

**CAUTION:** Steering knuckle hole, ball stud and nut should be free of dirt and grease before tightening nut.

2. Install ball stud nuts and tighten nut to specifications. (See Specification Section.)

**CAUTION:** If necessary, tighten one more notch to insert cotter pins. Do not loosen nut to insert cotter pin. Refer to Ball Joint text for proper nut installation sequence.

3. Reverse remaining removal procedure, and tighten splash shield mounting bolt. Tighten two caliper assembly mounting bolts to 35 ft. lb. torque.
4. Adjust wheel bearings as outlined under Front Wheel Bearing Adjustment.
5. Tighten wheel nuts to 75 ft. lb.

### CROSSMEMBER AND SUSPENSION UNIT

Component parts of the front suspension may be serviced separately as outlined in the preceding service operations. However, if extensive service is to be performed to crossmember, frame, etc., the unit can be removed and installed as follows:

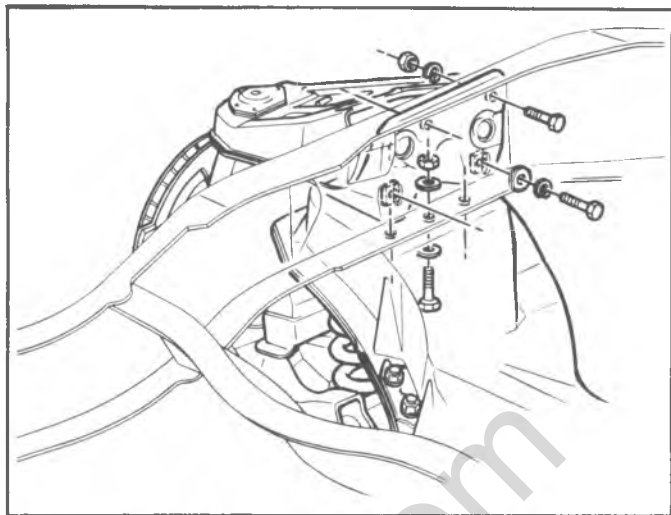

Fig. 39—Suspension Unit to Frame — Typical

#### Removal (Fig. 39)

1. Place vehicle on hoist and remove the shock absorber from the lower control arm.
2. Remove idler arm and pitman arm.
3. Support engine and remove front engine mount center bolts.
4. Separate main brake feeder line from crossmember tee.
5. Remove bolts retaining crossmember hangers to frame side rails.
6. If equipped with brake support struts remove bolts retaining struts to crossmember and frame and remove.
7. Remove bolts securing crossmember to frame bottom rail and lower the assembly from vehicle.

#### Installation

**CAUTION:** See CAUTION on page 1 of this section regarding the fasteners referred to in steps 1, 2, 3, 4, 5, 6 and 7.

1. Jack crossmember into position under frame and install frame bottom rail mounting bolts.
2. Install bolts securing crossmember hanger to frame and torque nuts. See specifications.
3. Position engine on front mount and install mounting bolt and torque (see Section 6).
4. Install the shock absorber.
5. Install brake support struts if previously removed.
6. Connect front brake main feeder line and bleed brakes as described in Section 5.
7. Install idler arm and pitman arm (see Section 9).
8. Check and Adjust front end alignment as outlined under "Maintenance and Adjustments" in this section.
9. Lower the vehicle to the floor.

## FRONT SUSPENSION DIAGNOSIS

### HARD STEERING

#### Probable Cause

- a. Ball joints and steering linkage need lubrication
- b. Low or uneven front tire pressure
- c. Power steering partially or not operative
- d. Steering gear not properly adjusted
- e. Incorrect front wheel alignment (manual steering)

#### Probable Remedy

- a. Lubricate ball joints and linkage
- b. Inflate tires to the proper recommended pressure
- c. Check power steering components for proper operation
- d. Adjust steering gear
- e. Check and align front suspension

### POOR DIRECTIONAL STABILITY

- a. Ball joints and steering linkage need lubrication
- b. Low or uneven front or rear tire pressure
- c. Loose wheel bearings
- d. Steering Gear not on high point
- e. Incorrect front wheel alignment (caster)
- f. Broken springs
- g. Malfunctioning shock absorber.
- h. Broken stabilizer bar, or missing link

- a. Lubricate at proper intervals
- b. Inflate tires to the proper recommended pressure
- c. Adjust wheel bearings
- d. Adjust steering gear
- e. Check and align front suspension
- f. Replace springs
- g. Diagnose shock absorbers.
- h. Replace stabilizer or link

### FRONT WHEEL SHIMMY (SMOOTH ROAD SHAKE)

- a. Tire and wheel out of balance, or out of round
- b. Worn or loose wheel bearings
- c. Worn tie rod ends
- d. Worn ball joints
- e. Malfunctioning shock absorber

- a. Balance tires, check run-out
- b. Adjust wheel bearings
- c. Replace tie rod end
- d. Replace ball joints
- e. Diagnose shock absorbers

### VEHICLE PULLS TO ONE SIDE (NO BRAKING ACTION)

- a. Low or uneven tire pressure
- b. Front or rear brake dragging
- c. Broken or sagging front spring
- d. Incorrect front wheel alignment (Camber)
- e. Power steering valve not centered (Corvette only)

- a. Inflate tires to the proper recommended pressure
- b. Adjust brakes
- c. Replace spring
- d. Check and align front suspension
- e. Balance valve

### EXCESSIVE PLAY IN STEERING

- a. Incorrect steering gear adjustment
- b. Worn steering gear parts

- a. Adjust steering gear
- b. Overhaul Gear (See sec. 9)

Fig. 40—Front Suspension Diagnosis

<b>NOISE IN FRONT END</b>	
<u>Probable Cause</u>	<u>Probable Remedy</u>
<ul style="list-style-type: none"> <li>a. Ball joints and steering linkage need lubrication</li> <li>b. Shock absorber loose or bushings worn</li> <li>c. Worn control arm bushings</li> <li>d. Worn tie rod ends</li> <li>e. Worn or loose wheel bearings</li> <li>f. Loose stabilizer bar</li> <li>g. Loose wheel nuts</li> <li>h. Spring improperly positioned</li> <li>i. Loose suspension bolts</li> </ul>	<ul style="list-style-type: none"> <li>a. Lubricate at recommended intervals</li> <li>b. Tighten bolts and/or replace bushings</li> <li>c. Replace bushings</li> <li>d. Replace tie rod ends</li> <li>e. Adjust or replace wheel bearings</li> <li>f. Tighten all stabilizer bar attachments</li> <li>g. Tighten the wheel nuts to proper torque</li> <li>h. Reposition (See fig. 24)</li> <li>i. Torque to specifications or replace</li> </ul>
<b>WHEEL TRAMP</b>	
<ul style="list-style-type: none"> <li>a. Tire and wheel out of balance</li> <li>b. Tire and wheel out of round</li> <li>c. Blister or bump on tire</li> <li>d. Improper shock absorber action</li> </ul>	<ul style="list-style-type: none"> <li>a. Balance wheels</li> <li>b. Replace tire</li> <li>c. Replace tire</li> <li>d. Replace shock absorber</li> </ul>
<b>EXCESSIVE OR UNEVEN TIRE WEAR</b>	
<ul style="list-style-type: none"> <li>a. Underinflated or overinflated tires</li> <li>b. Improper toe-in</li> <li>c. Wheels out of balance</li> <li>d. Hard Driving</li> <li>e. Over loaded vehicle</li> </ul>	<ul style="list-style-type: none"> <li>a. Inflate tire to proper recommended pressure</li> <li>b. Adjust toe-in</li> <li>c. Balance wheels</li> <li>d. Instruct driver</li> <li>e. Instruct driver</li> </ul>
<b>SCUFFED TIRES</b>	
<ul style="list-style-type: none"> <li>a. Toe-in incorrect</li> <li>b. Excessive speed on turns</li> <li>c. Tires improperly inflated</li> <li>d. Suspension arm bent or twisted</li> </ul>	<ul style="list-style-type: none"> <li>a. Adjust toe-in to specifications</li> <li>b. Advise driver</li> <li>c. Inflate tires to proper recommended pressure</li> <li>d. Replace arm</li> </ul>
<b>CUPPED TIRES</b>	
<ul style="list-style-type: none"> <li>a. Front shock absorbers defective</li> <li>b. Worn ball joints</li> <li>c. Wheel bearings incorrectly adjusted or worn</li> <li>d. Wheel and tire out of balance</li> <li>e. Excessive tire or wheel runout</li> </ul>	<ul style="list-style-type: none"> <li>a. Replace shock absorbers</li> <li>b. Replace ball joints</li> <li>c. Adjust or replace wheel bearings</li> <li>d. Balance wheel and tire</li> <li>e. Compensate for runout - (See Section 10 Theory and Diagnosis)</li> </ul>

Fig. 41—Front Suspension Diagnosis

**"DOG" TRACKING**Probable CauseProbable Remedy**LEAF TYPE REAR SPRING**

- a. Rear leaf spring broken
- b. Bent rear axle housing
- c. Frame or underbody out of alignment

- a. Replace spring
- b. Replace housing
- c. Align frame

**COIL TYPE REAR SPRING**

- a. Damaged rear suspension arm and/or worn bushings
- b. Frame out of alignment
- c. Bent rear axle housing

- a. Replace suspension arm and/or bushings
- b. Align frame
- c. Replace housing

**RETURNABILITY POOR**

- a. Steering column alignment (Nova)
- b. Steering linkage needs lubrication
- c. Idler arm bushing worn
- d. Steering gear adjustment
- e. Power steering gear valve spool binding
- f. Obstruction within power steering gear
- g. Improper caster setting (negative)

- a. See Section 9 in shop manual for proper alignment
- b. Lubricate chassis
- c. Replace idler arm
- d. Adjust gear as outlined in Section 9 of shop manual
- e. See Section 9 in shop manual
- f. See Section 9 in shop manual
- g. Check and reset if necessary

**ERRATIC STEERING ON BRAKE APPLICATION**

- a. Low or uneven tire pressure
- b. Front wheel bearing incorrectly adjusted
- c. Brakes incorrectly or unevenly adjusted
- d. Front spring sagged
- e. Steering gear off high point
- f. Incorrect or uneven caster
- g. Leaking wheel cylinders

- a. Inflate tires to proper recommended pressure
- b. Adjust bearing as necessary
- c. Adjust brakes as necessary
- d. Check shop manual for proper riding heights and replace spring if necessary
- e. Check and correct steering if necessary
- f. Check and adjust caster as necessary
- g. Replace (See sec. 5)

Fig. 42—Front Suspension Diagnosis

## BALL JOINT DIAGNOSTIC PROCEDURE

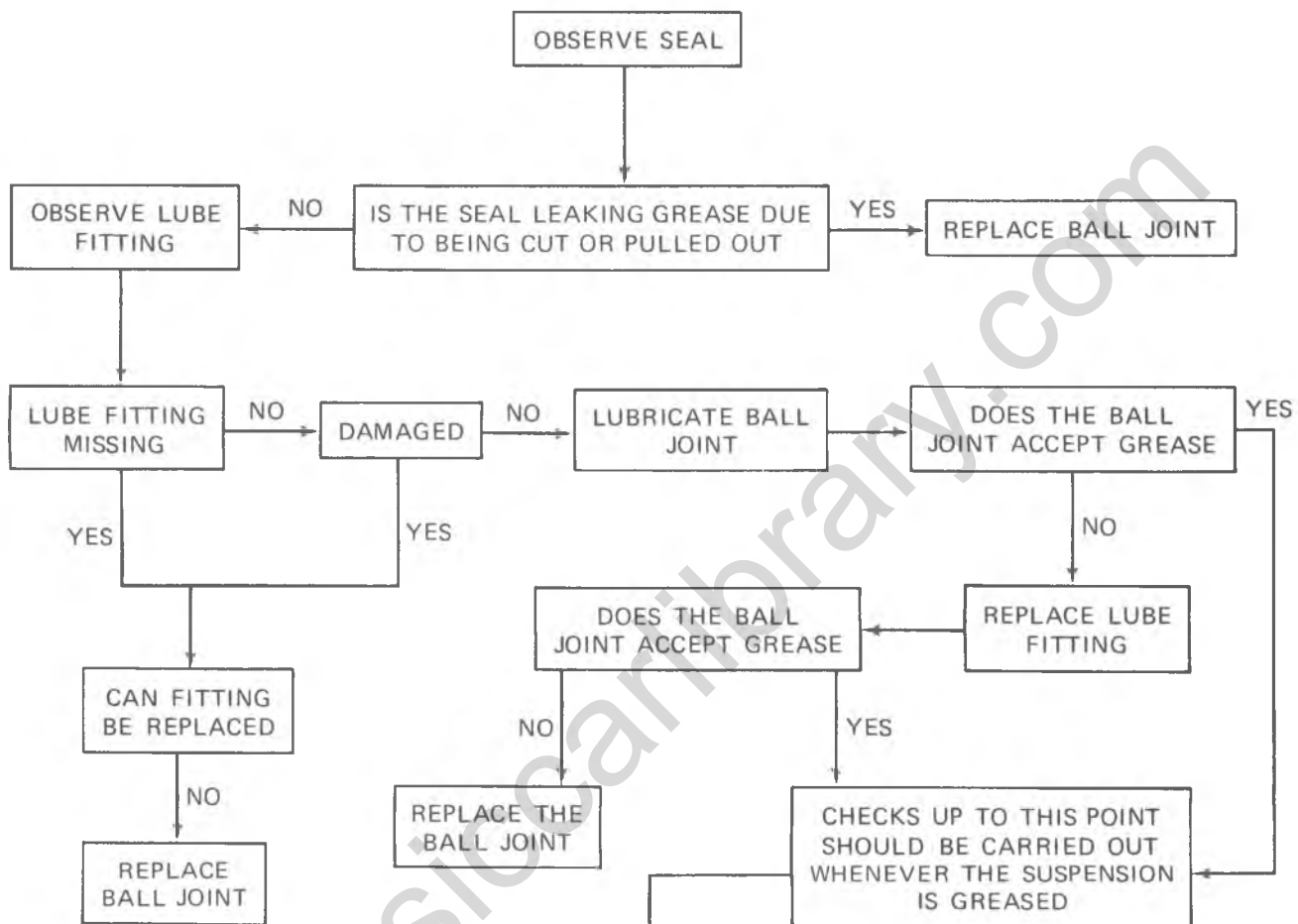

BALL JOINTS SHOULD BE CHECKED FOR LOOSENESS AND WEAR WHENEVER FRONT WHEEL SHIMMY, WANDER, SCUFFED TIRES, CUPPED TIRES AND EXCESSIVE STEERING PLAY ARE NOTED. IF ANY OF THE ABOVE PROBLEMS ARE NOTED CONTINUE THE DIAGNOSTIC PROCEDURE AS OUTLINED IN THE CHASSIS SERVICE MANUAL AS APPLICABLE TO EACH VEHICLE.

Fig. 43—Ball Joint Diagnostic Procedure except K Series



## SHOCK ABSORBER DIAGNOSIS

### ON VEHICLE CHECKS

(Follow the Procedures Outlined Below in the Order Indicated).

#### Preliminary Inspection and Ride Test:

##### Tire Pressure

Check tire pressure compare to vehicle specifications and adjust as required. Poor vehicle control and ride complaints are caused in many cases by improper tire inflation.

##### Special Suspension Equipment

Check Service Parts Identification Sticker for any special suspension equipment; such as, a heavy duty suspension. Vehicles equipped with this type of option have a somewhat stiffer or harsh ride, and this should be kept in mind during the following tests. If complaint about stiffness should occur while vehicle is still new (under 5,000 miles), owner should be advised to have ride rechecked after 7,000 to 8,000 miles.

##### Vehicle Load Conditions

Note any exceptional load conditions under which the owner normally operates the vehicle; such as, large tool boxes full of tools, pick up bed full etc. If exceptional loading is apparent, check the distribution of this weight. Note if it is all toward one side of the vehicle or at the extreme rear of the vehicle. Reposition load as required to obtain a more uniform weight distribution.

##### Check Vehicle Ride and Handling

After completing previous checks, ride vehicle with owner to determine if problem has been corrected or to definitely establish type of problem that still exists. If problem still exists (poor handling, bottoming, noise, ride sway, etc.), proceed.

##### Inspecting and Testing the Shocks

Three procedures are included in this step. They are (a) Bounce Test, (b) Inspecting Shock Mountings for Noise (Looseness) and (c) Manually Operating Shocks to Determine if Shocks are Weak, Leaking Hydraulic Fluid, and/or if Shocks have an Internal Noise Condition.

**IMPORTANT:** Test procedures (b) and (c) require vehicle to be on a hoist that supports wheels or rear axle housing and front lower control arms.

##### Bounce Test

**NOTE:** This is only a comparison type test to help locate the suspected shock or noise condition before proceeding.

Test each front and rear shock by bouncing each corner of the vehicle. This can usually be done by lifting up and pushing down on the end of the bumper near each corner of the vehicle until maximum movement up and down is reached. Then let go of bumper and observe if

the up and down motion stops very quickly. If up and down motion continues longer at one corner when compared to opposite corner (example, both front shocks), the one having the longer up and down motion may be suspect. **Do Not** compare front to rear. If complaint is noise, this test should help to locate the suspected area.

##### Inspecting Shock Mountings

If noisy and/or loose shock mountings are suspected, place vehicle on hoist that supports wheels and check all mountings for the following conditions:

- (1) Worn or defective grommets
- (2) Loose mounting nuts
- (3) Possible interference condition
- (4) Bump stops missing

If no apparent defects are noted in this step but noise condition still exists when vehicle is bounced up and down, proceed.

##### Inspecting Shocks for Leaks and Manually Operating Shocks

This procedure is sub-divided into two general areas, (1) Inspecting Shocks for Loss of Hydraulic Fluid and (2) Manually Operating Shock. It should aid the technician to localize defective shocks caused by internal noise in the shock, weak, leaking, etc.

##### 1. Inspecting Shocks for Possible Loss of Hydraulic Fluid.

- (a) Disconnect each shock lower mounting as required and pull down on the shock until it is fully extended.
- (b) Inspect shocks for leaks in seal cover area. Shock fluid is a very thin hydraulic fluid and has a characteristic odor and dark brown tint (Figure 44).

Certain precautions should be observed when inspecting shocks for leaks:

- shocks may have glossy paint on them. Do not confuse this paint with a leak condition.
- a slight trace of shock fluid around the seal cover area is **not** cause for replacement. The shock seal is engineered to permit a slight seepage to lubricate the rod. The shock absorber has reserve fluid to compensate for the slight seepage.
- shocks are sometimes incorrectly diagnosed as leakers due to oil spray originating from some other source. If in doubt, wipe the wet area from and manually operate shock as described in Step (2). Fluid will reappear if shock is leaking.

##### 2. Manually Operating Shocks.

**NOTE:** It may be necessary with certain types of shock mountings to fabricate a

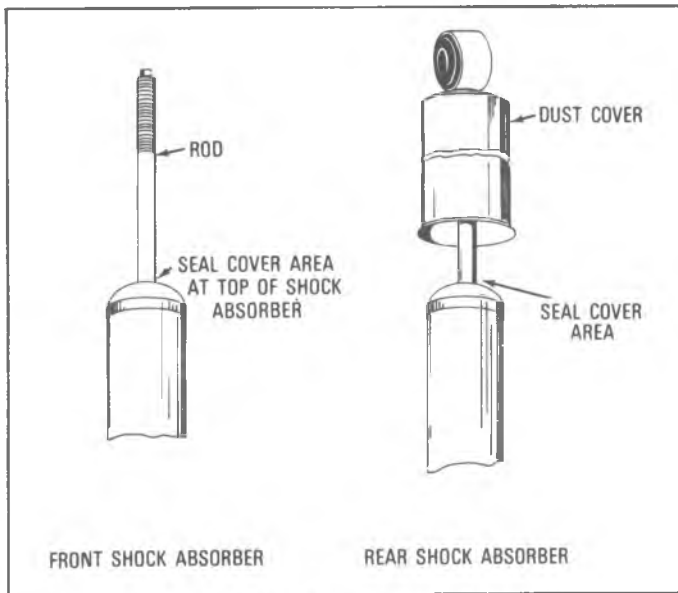

Fig. 44—Seal Cover Area of Shock

bracket that can be installed on a shock to enable a technician to securely grip the shock when manually operating the shock. See Figure 45 for suggested methods of providing temporary grip.

This test should help the mechanic to isolate the following shock defects:

- binding condition internally
- verify leaking shock
- improper or defective valving

- (a) If suspected problem is in front shocks, disconnect both front shock lower mountings and stroke each shock as follows: Grip the lower end of the shock securely and pull down (rebound stroke) then push up (compression stroke). The control arms will limit the

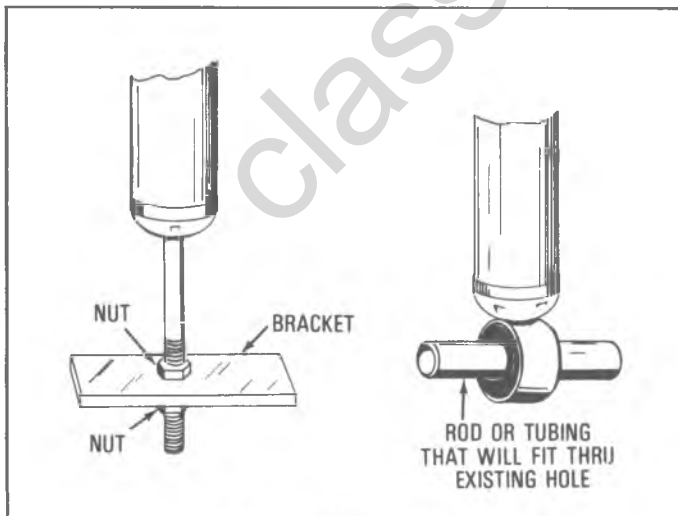

Fig. 45—Gripping Methods

movement of the front shocks during the compression stroke. Compare the rebound resistance between both front shocks, then compare the compression resistance. If a noticeable difference can be felt during either stroke, usually the shock having the least resistance is at fault.

- (b) If shock has an internal noise condition, extend shock fully, then exert an extra pull. If noisy shock should be replaced.

Other noise conditions that require shock replacement are:

- a grunt or squeal after one full stroke in both directions
- a clicking noise on fast reverse
- a skip or lag at reversal near mid-stroke

**IMPORTANT:** When air adjustable shocks are being manually operated, the air line must be disconnected at the shock absorber.

### BENCH CHECKS

The bench checks are recommended if the proper type hoist is not available to perform the “on car” tests, or if there is still some doubt as to whether the shocks are defective. In addition, the bench test allows a more thorough visual inspection.

Bench check procedures are discussed for three general types of shocks.

### SPIRAL GROOVE RESERVOIR

**IMPORTANT:** If this type of shock has been stored or allowed to lay in a horizontal position for any length of time, an air void will develop in the pressure chamber of the shock absorber. This air void if not purged, can cause a technician to diagnose the shock as defective. To purge the air from the pressure chamber, proceed as follows: (Refer to figure 46)

- (a) Holding the shock in its normal vertical position (top end up), fully extend shock.
- (b) Hold the top end of the shock **down** and fully collapse the shock.
- (c) Repeat Steps (a) and (b) at least five (5) times to assure air is purged.

### Bench Test Procedure

1. This is a comparison type test. If possible, obtain a new or known good shock with same part number as shock under test.
2. With shocks in vertical position (top end up), clamp bottom mounts in vise.

**CAUTION:** Do not clamp on reservoir tube or mounting threads.

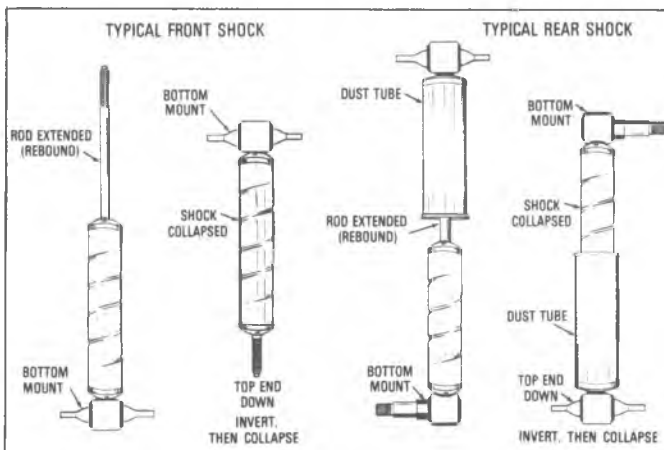

Fig. 46—Position for Purging Air From Shocks

3. Manually pump each shock by hand at various rates of speed and compare resistance of suspected shock with the new one.

**NOTE:** Rebound resistance (extending the shock) is normally stronger than the compression resistance (approximately 2:1). However, resistance should be smooth and constant for each stroking rate.

4. Observe or listen for the following conditions that will indicate a defective shock:
  - a skip or lag when reversing stroke at mid travel.
  - seizing or binding condition except at extreme end of either stroke.
  - a noise, such as a grunt or squeal, after completing one full stroke in both directions.
  - a clicking type noise at fast reversal.
  - fluid leakage.
5. To check for a loose piston, completely extend shock to full rebound; then exert an extra hard pull. If a give is felt, a loose piston is indicated and shock should be replaced.

### PLIACELL OR GENETRON

Pliacell and Genetron are some of the trade names used to indicate a gas-filled cell in the shock reservoir. The reservoirs of Pliacell and Genetron shocks are smooth, compared to the spiral groove type. The cell takes the place of air in the reservoir. Thus, aeration or foaming of the fluid is eliminated, as air and fluid cannot mix.

Due to this feature, these shocks should be bench checked in an **inverted position** (top end down). If, when stroked, a lag is noticed, it means the gas-filled cell has been ruptured, and the shock should be replaced. If no lag is noticed, the remainder of the bench check is the same as given in the Spiral Groove Reservoir, Section 1, Bench Check Procedure.

### AIR ADJUSTABLE SHOCKS

This type of shock contains an air chamber like the spiral groove reservoir type, and must have the air purged from the working chamber. See Section 1, Spiral Groove Reservoir. After air has been purged from shock, proceed as follows:

- (a) Clamp lower shock mounting ring in vise in vertical position with larger diameter tube at the top.
- (b) Pump unit by hand at different rates of speed. Smooth resistance should be felt through the length of the stroke. Since the units are normally pressurized, the sound of air bubbles or a gurgling noise is **normal**.
- (c) The remainder of the bench check is the same as given in the Spiral Groove Reservoir, Section 1, Bench Check Procedure.

### BEARINGS AND RACES

#### BENCH DIAGNOSTIC PROCEDURE

This section describes common types of bearing distress and their causes. Illustrations are included to help diagnose the cause of distress and comments are provided to help make effective repairs.

#### Consider The Following Factors When Diagnosing Bearing Distress:

1. Note General Condition of all parts during teardown and examinations.
2. Classify the failure with the aid of these illustrations where possible.
3. Determine the cause. Recognizing the cause will permit correction of the problem and prevent a repeat failure of the same type.
4. Make all repairs following recommended procedures.

#### Common Causes For Bearing Distress Includes The Following:

1. Improper adjustment or preloading.
2. Mounting or teardown abuse.
3. Improper mounting methods.
4. Inadequate or wrong lubricants.
5. Entrance of dirt or water.
6. Wear from dirt or metal chips.
7. Corrosion or rusting.
8. Seizing or smearing from overload.
9. Overheating causing tempering.
10. Fretting of bearing seats.
11. Brinelling from impact loads and shipping.
12. Manufacturing defects.
13. Fatigue pitting and spalling.

## DIAGNOSIS

### FRONT WHEEL, PINION, DIFFERENTIAL SIDE AND REAR WHEEL ROLLER BEARINGS

	EXCESS NOISE COMPLAINT DIAGNOSTIC PROCEDURE
Road Test	<ol style="list-style-type: none"> <li>1. Check tires for irregular wear</li> <li>2. Check tire pressure</li> <li>3. Check lubricant level</li> <li>4. Drive to warm-up rear axle</li> <li>5. Test at various speeds in drive, float, coast and cornering</li> </ol>
Tire Noises	<ol style="list-style-type: none"> <li>1. Change tire pressure to minimize noises</li> <li>2. Drive over different road surfaces</li> <li>3. Smooth black-top minimizes tire noise</li> <li>4. Cross switch tires, if necessary</li> <li>5. Snow tire treads and studs caused added noises</li> </ol>
Engine or Exhaust Noises	<ol style="list-style-type: none"> <li>1. Drive slightly above speed where noise occurs, place transmission in neutral</li> <li>2. Let engine speed drop to idle</li> <li>3. Stop car</li> <li>4. Run engine at various speeds</li> </ol>
Test for Wheel Bearing Noise	<ol style="list-style-type: none"> <li>1. Drive car at low speed on a smooth road</li> <li>2. Turn car to develop left and right motions, traffic permitting</li> <li>3. Noise should change due to cornering loads</li> <li>4. Jack-up wheels to verify roughness at wheels</li> </ol>
Test for Differential Bearing Noise	<ol style="list-style-type: none"> <li>1. Drive car at low speed on a smooth road</li> <li>2. Constant low pitch bearing noise may be heard</li> <li>3. Noise should not change in reversing turns</li> <li>4. Noise pattern should vary with wheel speed</li> </ol>
Test for Pinion Bearing Noise	<ol style="list-style-type: none"> <li>1. Roughness or whine noise should increase with speed</li> <li>2. Noise pitch should be higher than differentials</li> <li>3. Test on smooth road to minimize tire noises</li> <li>4. Test at various speeds in drive, float, and coast</li> <li>5. Rear pinion bearing noise may be louder on acceleration</li> <li>6. Front pinion bearing noise may be louder on deceleration</li> <li>7. Gear noises tend to peak in a narrow speed range</li> </ol>

Fig. 47—Bearing Diagnosis

# FRONT WHEEL BEARING DIAGNOSIS

CONSIDER THE FOLLOWING FACTORS WHEN DIAGNOSING BEARING CONDITION:

1. GENERAL CONDITION OF ALL PARTS DURING DISASSEMBLY AND INSPECTION.
2. CLASSIFY THE FAILURE WITH THE AID OF THE ILLUSTRATIONS.
3. DETERMINE THE CAUSE.
4. MAKE ALL REPAIRS FOLLOWING RECOMMENDED PROCEDURES









 <p><b>ABRASIVE ROLLER WEAR</b></p> <p>PATTERN ON RACES AND ROLLERS CAUSED BY FINE ABRASIVES.</p> <p>CLEAN ALL PARTS AND HOUSINGS. CHECK SEALS AND BEARINGS AND REPLACE IF LEAKING, ROUGH OR NOISY.</p>	 <p><b>GALLING</b></p> <p>METAL SMEARS ON ROLLER ENDS DUE TO OVERHEAT, LUBRICANT FAILURE OR OVERLOAD (WAGON'S)</p> <p>REPLACE BEARING - CHECK SEALS AND CHECK FOR PROPER LUBRICATION.</p>	 <p><b>BENT CAGE</b></p> <p>CAGE DAMAGE DUE TO IMPROPER HANDLING OR TOOL USAGE.</p> <p>REPLACE BEARING.</p>
 <p><b>ABRASIVE STEP WEAR</b></p> <p>PATTERN ON ROLLER ENDS CAUSED BY FINE ABRASIVES.</p> <p>CLEAN ALL PARTS AND HOUSINGS. CHECK SEALS AND BEARINGS AND REPLACE IF LEAKING, ROUGH OR NOISY.</p>	 <p><b>ETCHING</b></p> <p>BEARING SURFACES APPEAR GRAY OR GRAYISH BLACK IN COLOR WITH RELATED ETCHING AWAY OF MATERIAL USUALLY AT ROLLER SPACING.</p> <p>REPLACE BEARINGS - CHECK SEALS AND CHECK FOR PROPER LUBRICATION.</p>	 <p><b>BENT CAGE</b></p> <p>CAGE DAMAGE DUE TO IMPROPER HANDLING OR TOOL USAGE.</p> <p>REPLACE BEARING</p>
 <p><b>INDENTATIONS</b></p> <p>SURFACE DEPRESSIONS ON RACE AND ROLLERS CAUSED BY HARD PARTICLES OF FOREIGN MATERIAL.</p> <p>CLEAN ALL PARTS AND HOUSINGS. CHECK SEALS AND BEARINGS AND REPLACE BEARINGS IF ROUGH OR NOISY.</p>	 <p><b>CAGE WEAR</b></p> <p>WEAR AROUND OUTSIDE DIAMETER OF CAGE AND ROLLER POCKETS CAUSED BY ABRASIVE MATERIAL AND INEFFICIENT LUBRICATION.</p> <p>CLEAN RELATED PARTS AND HOUSINGS. CHECK SEALS AND REPLACE BEARINGS.</p>	 <p><b>MISALIGNMENT</b></p> <p>OUTER RACE MISALIGNMENT</p> <p>CLEAN RELATED PARTS AND REPLACE BEARING. MAKE SURE RACES ARE PROPERLY SEATED.</p>

Fig. 48—Bearing Diagnosis

## FRONT WHEEL BEARING DIAGNOSIS (CONT'D)

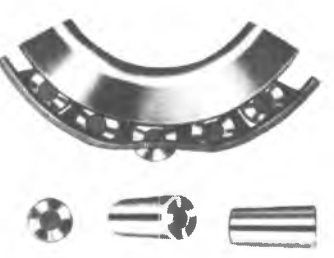









 <p><b>CRACKED INNER RACE</b></p> <p>RACE CRACKED DUE TO IMPROPER FIT, COCKING, OR POOR BEARING SEATS.</p> <p>REPLACE BEARING AND CORRECT BEARING SEATS.</p>	  <p><b>FATIGUE SPALLING</b></p> <p>FLAKING OF SURFACE METAL RESULTING FROM FATIGUE.</p> <p>REPLACE BEARING -- CLEAN ALL RELATED PARTS.</p>	  <p><b>BRINELLING</b></p> <p>SURFACE INDENTATIONS IN RACEWAY CAUSED BY ROLLERS EITHER UNDER IMPACT LOADING OR VIBRATION WHILE THE BEARING IS NOT ROTATING.</p> <p>REPLACE BEARING IF ROUGH OR NOISY.</p>
 <p><b>FRETTAGE</b></p> <p>CORROSION SET UP BY SMALL RELATIVE MOVEMENT OF PARTS WITH NO LUBRICATION.</p> <p>REPLACE BEARING. CLEAN RELATED PARTS. CHECK SEALS AND CHECK FOR PROPER LUBRICATION.</p>	  <p><b>STAIN DISCOLORATION</b></p> <p>DISCOLORATION CAN RANGE FROM LIGHT BROWN TO BLACK CAUSED BY INCORRECT LUBRICANT OR MOISTURE.</p> <p>RE-USE BEARINGS IF STAINS CAN BE REMOVED BY LIGHT POLISHING OR IF NO EVIDENCE OF OVER HEATING IS OBSERVED.</p> <p>CHECK SEALS AND RELATED PARTS FOR DAMAGE.</p>	  <p><b>HEAT DISCOLORATION</b></p> <p>HEAT DISCOLORATION CAN RANGE FROM FAINT YELLOW TO DARK BLUE RESULTING FROM OVER-LOAD OR INCORRECT LUBRICANT.</p> <p>EXCESSIVE HEAT CAN CAUSE SOFTENING OF RACES OR ROLLERS.</p> <p>TO CHECK FOR LOSS OF TEMPER ON RACES OR ROLLERS A SIMPLE FILE TEST MAY BE MADE. A FILE DRAWN OVER A TEMPERED PART WILL GRAB AND CUT METAL, WHEREAS, A FILE DRAWN OVER A HARD PART WILL GLIDE READILY WITH NO METAL CUTTING.</p> <p>REPLACE BEARINGS IF OVER HEATING DAMAGE IS INDICATED. CHECK SEALS AND OTHER PARTS.</p>
 <p><b>SMEARS</b></p> <p>SMEARING OF METAL DUE TO SLIPPAGE. SLIPPAGE CAN BE CAUSED BY POOR FITS, LUBRICATION, OVERHEATING, OVERLOADS OR HANDLING DAMAGE.</p> <p>REPLACE BEARINGS, CLEAN RELATED PARTS AND CHECK FOR PROPER FITS AND LUBRICATION.</p>		

Fig. 49—Bearing Diagnosis

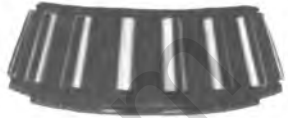

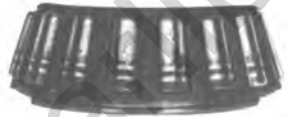
- |                        |                                      |                |                      |
|------------------------|--------------------------------------|----------------|----------------------|
| 1. J-8457              | Bearing Race Installer               | 6. J-8092      | Driver Handle        |
| 2. J-8458              | Bearing Race Installer               | 7. J-9519-9    | Ball Joint Installer |
| 3. J-8849              | Bearing Race Installer               | 8. J-9519-7    | Ball Joint Remover   |
| 4. J-9276-2            | Bearing Race Installer               | 9. J-9519-10   | "C" Clamp            |
| 5. J-24435-1<br>thru 7 | Bushing Replacement<br>C 10, G 10-20 | 10. J-23028-01 | Spring Remover       |
|                        |                                      | 11. J-23742-1  | Ball Joint Remover   |

Fig. 50—Special Tools

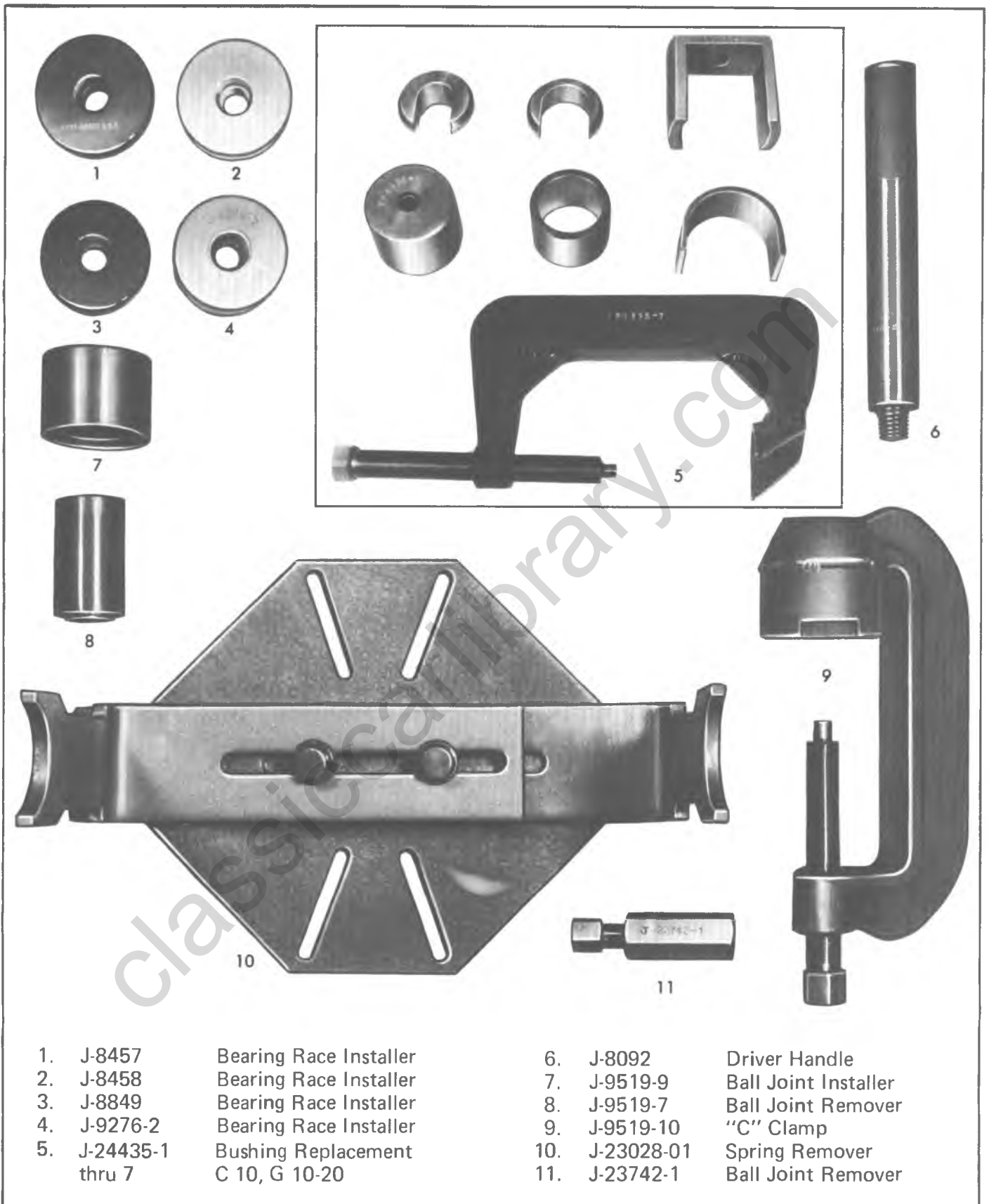
## FOUR WHEEL DRIVE (SERIES K10 AND K20)

### INDEX

General Description .....	3-38	Removal.....	3-41
Front Axle .....	3-38	Installation .....	3-43
Transfer Case.....	3-38	Disassembly .....	3-43
Adapter Assembly.....	3-38	Wheel Hub .....	3-44
Free Wheeling Hubs.....	3-38	Spindle .....	3-44
Maintenance and Adjustments .....	3-39	Axle Joint.....	3-44
Ball Joint Adjustment .....	3-39	Ball Joint Service.....	3-46
Wheel Bearing Adjustment .....	3-48	Assembly .....	3-46
Component Parts Replacement .....	3-40	Replacement of Knuckle Assembly .....	3-47
Free Wheeling Hubs.....	3-40	Spindle Components.....	3-48
K-10 Series .....	3-40	Wheel Hub Components.....	3-48
K-20 Series .....	3-41	Wheel Bearing Adjustment .....	3-48
Front Axle Assembly .....	3-41	Special Tools .....	3-49

### GENERAL DESCRIPTION

Primary purpose of four wheel drive is to provide additional tractive effort in off-the-road driving in order to overcome such obstacles as sand, deep mud or snow, hilly terrain with steep grades, etc.

With four wheels capable of driving, all the vehicle and payload weight is utilized to give maximum tire traction.

The power unit is driven through a transmission and consists of an adapter and a two-speed transfer case with a steering and driving front axle. A single control lever is used to shift the transfer case from direct drive to low four wheel drive at a ratio of 1.94 to 1, thus eight forward speeds and two in reverse are provided.

Some vehicles (utility with automatic transmission and eight cylinder engines) are equipped with a new Full Time 4 wheel drive transfer case see section 7 for further information.

Front wheel drive may be engaged or disengaged at any time without clutching when the transfer case is in direct drive; however, in returning to 2 wheel drive from 4 wheel drive the accelerator may have to be varied as steady pressure is applied on lever. This releases gear tooth pressure during shifting.

A yoke and trunnion universal joint permits continuous power flow to each front wheel, regardless of the turning angle.

Provisions for Power Take-off have been incorporated in the transfer case.

#### FRONT AXLE

The front axle is a hypoid gear axle unit equipped with steering knuckles. Axle assembly number and production

date are stamped on left tube of assembly. Conventional truck service brakes are provided on all 4-wheel drive units.

#### TRANSFER CASE

The transfer case is basically the device which controls the "high" and "low" gear ranges. The shifting into "low" range also initiates four wheel driving action by connecting thru the front and rear axles. Four wheel drive is also possible in the 4-HI range. Utility vehicles with automatic transmission and eight cylinder engines are equipped with a new Full Time 4 wheel drive system.

Refer to Section 7 for service procedures.

#### ADAPTER ASSEMBLY

The adapter assembly is the means of making a mechanical connection between the transmission and the transfer case. Different adapters are used dependent upon the transmission and transfer case with which the vehicle is equipped. Refer to Section 7 for service procedures.

#### FREE WHEELING HUBS (Fig. 51)

Free-wheeling hubs are available for the front wheels of all four wheel drive vehicles except those equipped with the new Full Time 4 wheel drive transfer case.

The engagement and disengagement of free-wheeling hubs is a manual operation which must be performed at each front wheel. The transfer case control lever must be in 2-wheel drive position when locking or unlocking hubs. Both hubs must be in the fully locked or fully unlocked position. They must not be in the free-wheeling position when low all wheel drive is used as the additional torque output in this position can subject the rear axle to severe strain and rear axle failure may result.



## MAINTENANCE AND ADJUSTMENTS

### BALL JOINT ADJUSTMENT

Front axle ball joint adjustment is generally necessary only when there is excessive play in steering, irregular wear on tires or persistent loosening of the tie rod is observed.

1. Raise vehicle on hoist then place jack stands just inside of front springs.
2. Disconnect connecting rod and tie rod to allow independent movement of each steering knuckle.

3. At top of knuckle, apply torque wrench to one of the steering arms attaching stud nuts, then check torque necessary to turn the steering knuckle.

Maximum torque should be: 20 ft. lbs. for Axle 44-B

NOTE: Knuckle should turn smoothly through turning arc but have no vertical end play.

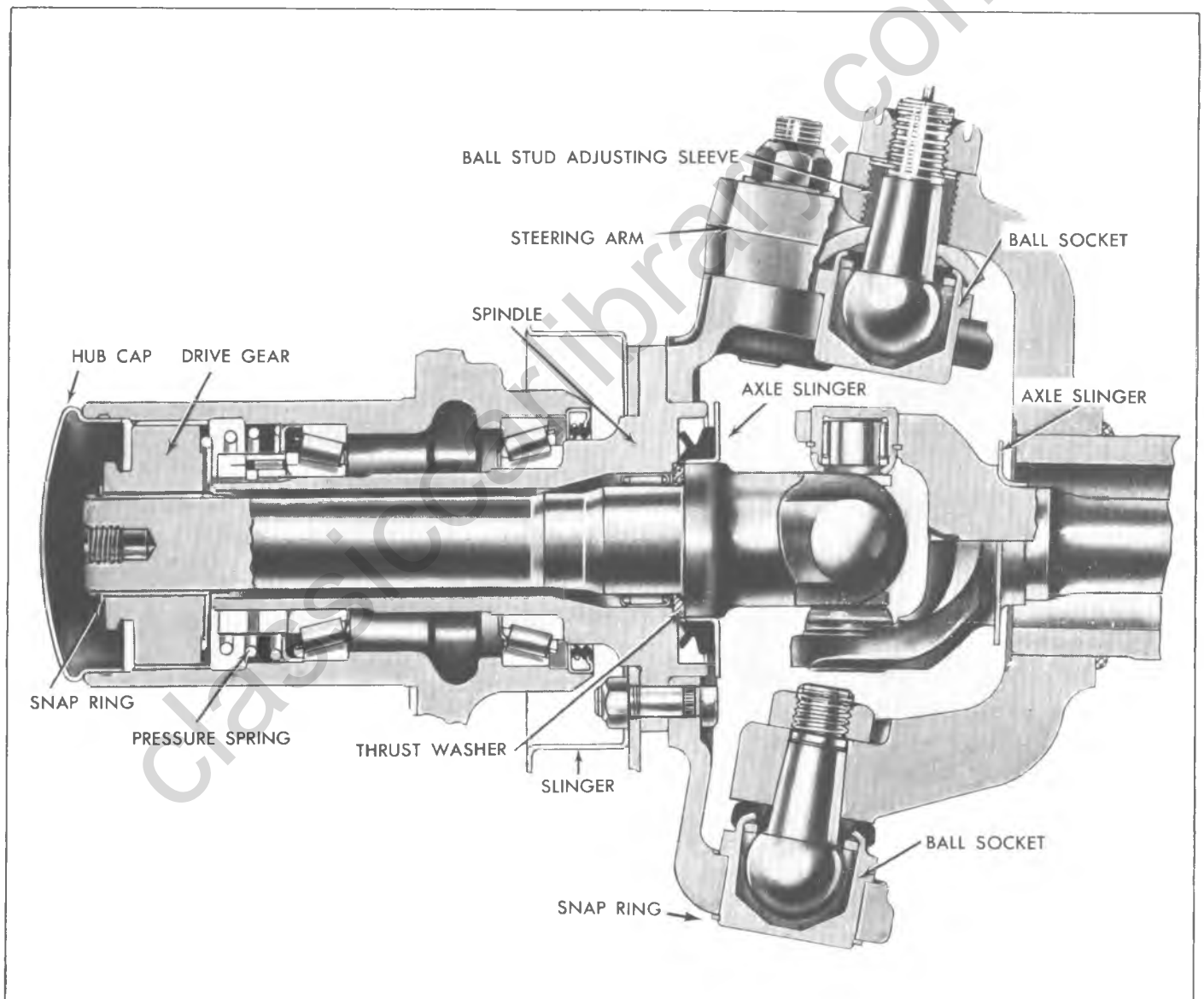

Fig. 51—Steering Knuckle and Hub Assembly

## COMPONENT PARTS REPLACEMENT

### FREE-WHEELING HUB

The free wheeling hub assemblies used on the front wheels are serviceable.

#### K10 Series (Fig. 54)

##### Removal (Fig. 52)

1. Turn actuator lever to set hub to "LOCK" position (fig. 53) and raise vehicle on hoist.
2. Remove six retaining plate bolts and remove retaining plate actuating knob and "O" ring.
3. Remove internal snap ring, outer clutch retaining ring and actuating cam body.
4. Relieve pressure on the axle shaft snap ring and remove snap ring.
5. Remove the axle shaft sleeve and clutch ring assembly and inner clutch ring and bushing assembly.
6. Remove pressure spring and spring retainer plate.

##### Disassembly

1. Remove actuator knob and "O" ring from retaining plate, discard "O" ring and replace with a new "O" ring during assembly.

2. Slide inner clutch ring and bushing assembly from axle sleeve and clutch ring assembly.

##### Inspection

1. Wash all parts in solvent and air dry.
2. Inspect all parts for wear, cracks or broken teeth.
3. Replace all "O" rings during assembly.

##### Assembly

Place new "O" ring seal on actuator knob. Apply lubri-plate to "O" ring and place actuator knob in retaining plate.

##### Installation

NOTE: All parts should be lubricated for normal operation during assembly with an ample amount of a Moly-XL, high speed grease. Lubrication MUST be applied to prevent deterioration before the unit is placed in service.

1. Install spring retainer plate (flange side facing bearing) over spindle nuts and seat retainer against bearing outer cup.
2. Install pressure spring into position. Large O.D. seats against spring retaining plate.

NOTE: Spring is an interference fit. When spring is seated, spring extends past the spindle nuts by approximately 7/8".

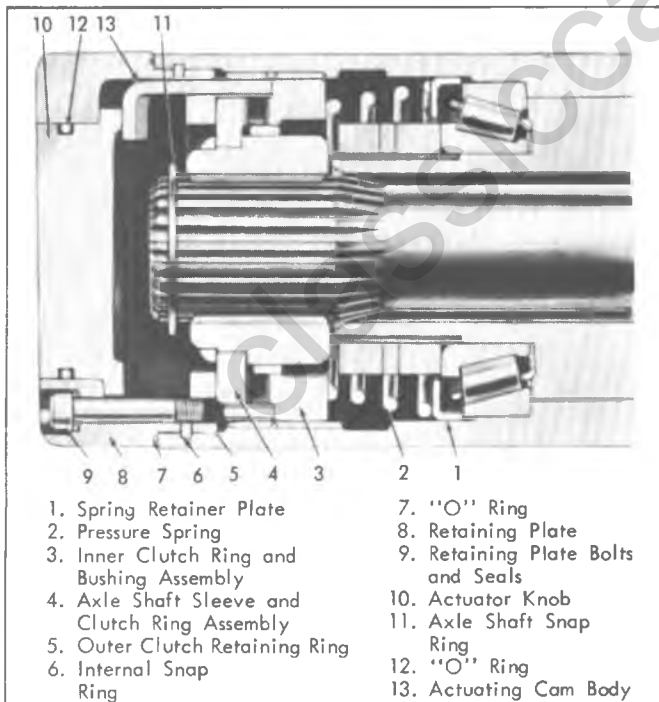

Fig. 52—Hub Assembly — K-10



Fig. 53—Hub Key Position — Typical

3. Place inner clutch ring and bushing assembly into axle shaft sleeve and clutch ring assembly and install as an assembly onto the axle shaft. Press in on assembly and install axle shaft snap ring.

NOTE: Install 7/16 x 20 bolt in axle shaft end and pull outward on axle shaft to aid in installing snap rings.

4. Install actuating cam body (cams facing outward), outer clutch retaining ring and internal snap ring.
5. Install "O" ring on retaining plate and install actuating knob and retaining plate.

NOTE: Install actuating knob with knob in "LOCK" position--grooves in knob must fit into actuator cam body.

6. Install six cover bolts and seals.
7. Turn knob to "FREE" position to check for proper operation.
8. Lower vehicle to floor.

### FREE-WHEELING HUB K20 Series (Fig. 54) Removal

1. Place vehicle on hoist and raise hoist.
2. Turn hub key knob to the "FREE" position.
3. Remove allen head bolts securing the retainer cap assembly to the wheel hub.
4. Pull off the hub cap assembly and gasket; also remove exterior sleeve extension housing and gasket.

#### Disassembly of Locking Hub Cap Assembly.

- a. Turn hub key knob to locked position.
  - b. Drive out key knob retainer roll pin.
  - c. Remove outer clutch gear assembly.
  - d. Remove lock ring and remove slotted adjustment sleeve.
  - e. Remove spring.
  - f. Remove lock ring securing the plastic key knob to the hub retainer cap.
  - g. Remove "O" ring from the plastic hub key knob.
5. Remove snap ring from end of axle shaft.
  6. Pull internal clutch gear and collar.

#### Inspection

1. Discard all seals, gaskets and "O" rings.
2. Wash all parts in solvent and air dry.
3. Inspect all parts for wear, cracks for broken teeth and replace as necessary.
4. Replace all seals gaskets and "O" rings.

#### Installation

NOTE: Apply a Moly-XL high speed lubricant, in generous amounts, to both faces

of the bushing, to the splines and teeth of the inner and outer clutch gears, and to the actuating cam. Lubrication MUST be applied to prevent deterioration before and during the actual service usage of the unit.

1. Install internal clutch gear collar and gear.
  2. Install lock ring at end of axle shaft.
  3. **Assembly of Locking Hub Cap Assembly.**
    - a. Use "O" ring lube and install the new "O" ring in the groove of the plastic hub key knob and insert into retainer cap.
    - b. Install the lock ring securing the plastic key knob to the hub retainer cap.
- NOTE: Check to see that lock ring is fully engaged into slot by pushing outward on the plastic knob.
- c. Install the slotted adjustment sleeve with the two tabs facing downward.
  - d. Install the key knob retaining roll pin with knob in "LOCKED" position.
  - e. Install spring.
  - f. Place outer clutch gear assembly on top of spring, compress spring and install lock ring at sleeve end.
  - g. Turn key knob to "FREE" position.

NOTE: Before continuing to install the extension housing and the assembled cap assembly, remove the head from a 3/8" bolt 5 inches long and use to align the assembly of parts to the hub.

4. Install above noted bolt alignment tool into one of the hub housing bolt holes.
5. Install the new exterior sleeve extension housing gasket and housing and the new hub retainer cap assembly gasket and cap assembly.
6. Install allen head bolts securing the retainer cap assembly to the wheel hub. Torque to specifications.
7. Turn hub key knob to the locked position to assure engagement into position.
8. Install wheel and tire assembly and lower vehicle to floor.

### FRONT AXLE ASSEMBLY (Refer to Fig. 55)

#### Removal

1. Disconnect propeller shaft from front axle differential.
2. Raise front of vehicle on hoist until weight is removed from front springs. Support truck with jack stands behind front springs.
3. Disconnect connecting rod from steering arm.
4. Disconnect brake hoses from frame fittings and cap

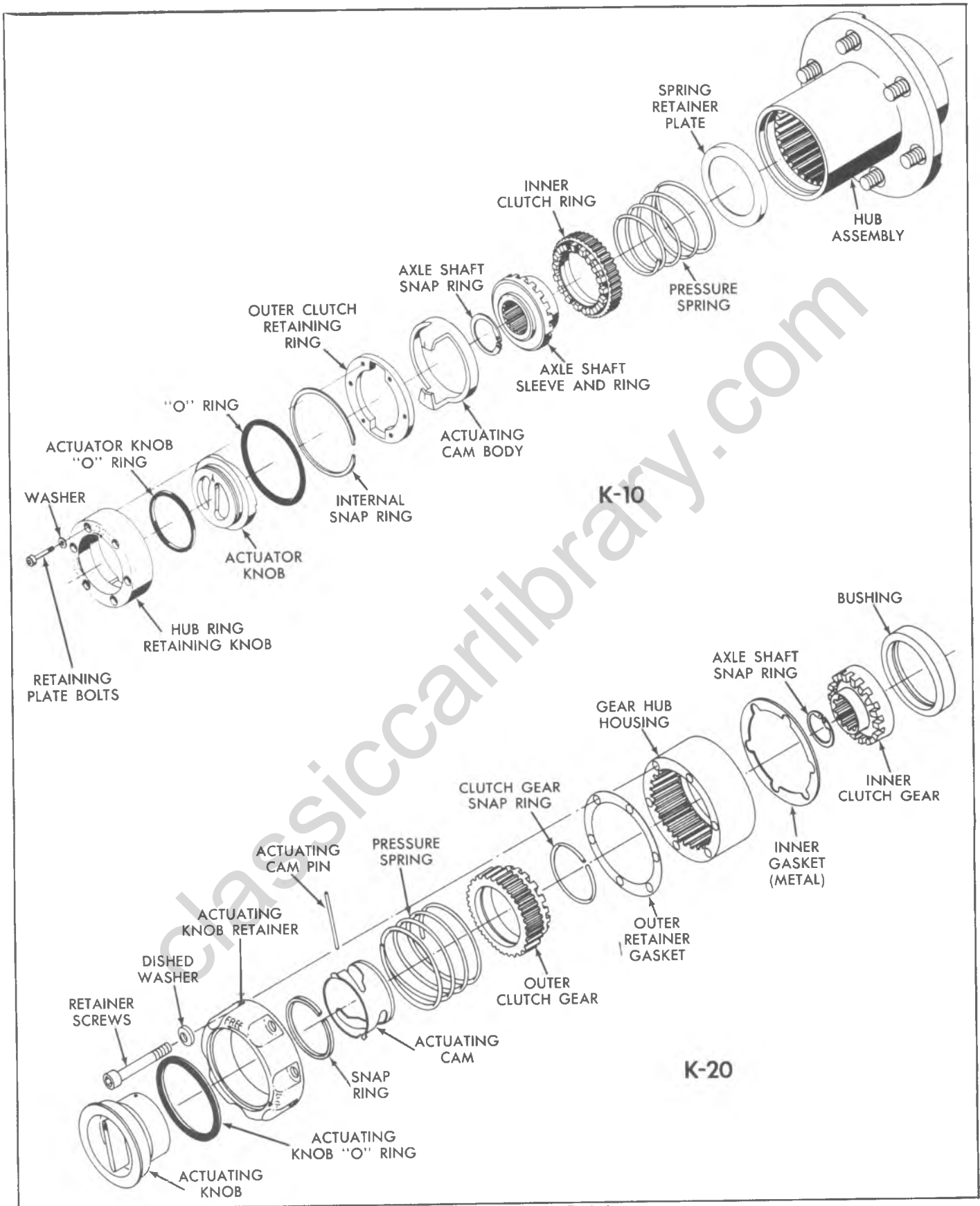

Fig. 54—Hub Assemblies - Explode

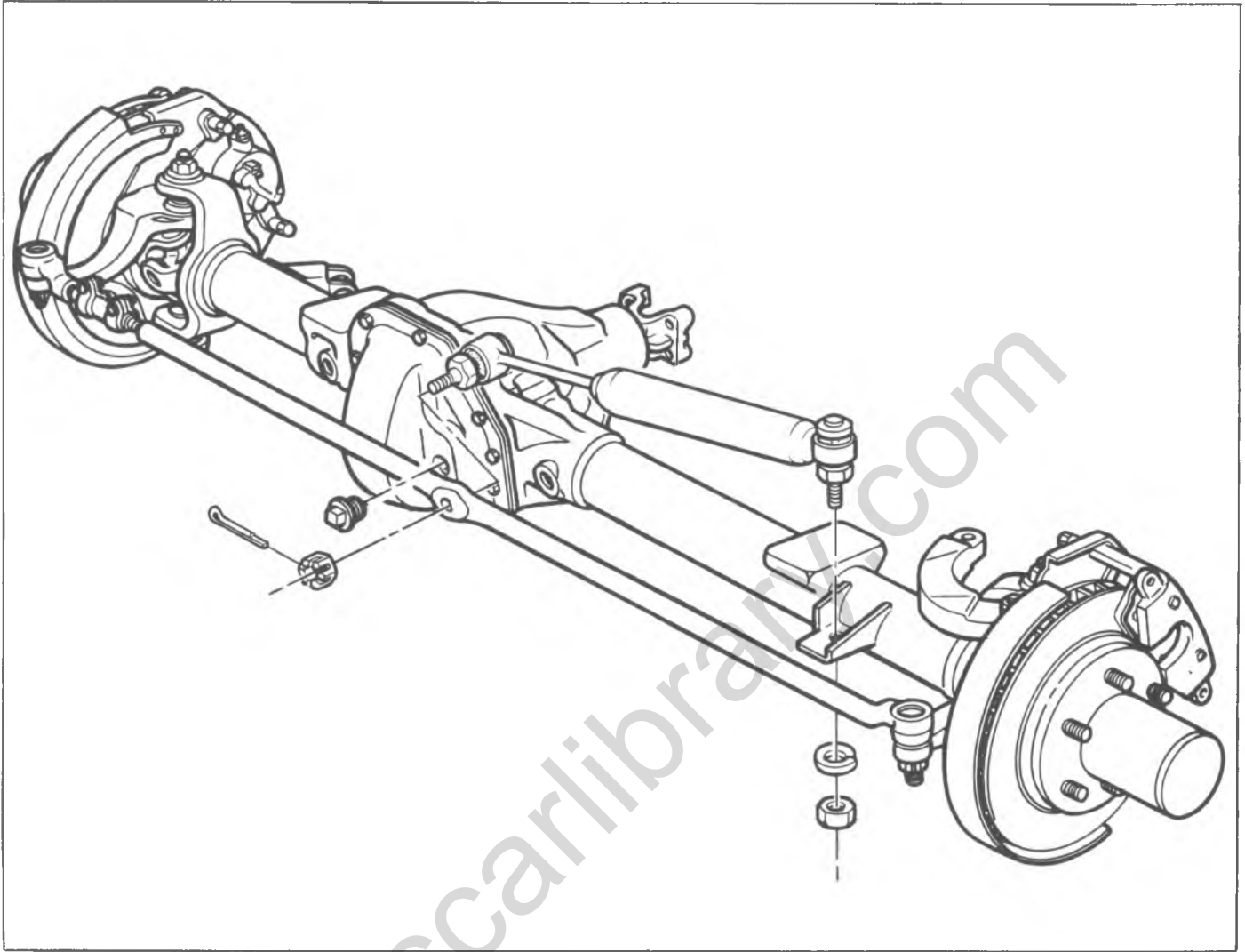

Fig. 55—Front Drive Axle Assembly

- all fitting ends or cover with a rag to prevent contamination.
5. Disconnect shock absorbers from axle brackets.
6. Disconnect axle vent tube clip at the differential housing (see fig. 56).
7. Dismount "U" bolts from axle to separate axle from truck springs.
8. Raise truck to clear axle assembly and roll front axle out from under the truck.

### Installation

**CAUTION:** See *CAUTION* on page 1 of this section regarding the fasteners referred to in steps 3, 5, 6 and 8.

1. Truck should be on jack stands as in Step 2 of removal instructions.
2. Place axle in position under truck.
3. Install "U" bolts attaching axle to front springs.
4. Attach shock absorbers to axle brackets.

5. Connect brake hoses to frame fittings bleed the brake system (see Section 5).
6. Attach connecting rod to steering arm.
7. Remove jack stands and lower front of truck.
8. Assemble propeller shaft to front axle differential.
9. Lower vehicle to floor.

### Disassembly

**NOTE:** Refer to K10 or K20 free wheeling hub for removal of 4-wheel drive units with a free wheeling hub assembly, before starting the disassembly of the front axle assembly.

1. Securely mount the axle assembly in a suitable holding fixture.
2. If the vehicle is not equipped with RPO F76 free-wheeling hubs, remove the hub cap and snap ring.
3. Remove the drive gear and pressure spring. Place a hand over the drive gear and use a screwdriver to pry the gear out.

### 3-44 FRONT SUSPENSION

4. Remove the wheel bearing outer lock nut, lock ring, and wheel bearing inner adjusting nut using Tool J-6893 and Adapter J-23446 or tool J-6893-01. (See fig. 58).
5. Remove the disc assembly, outer wheel bearing and the spring retainer plate.

NOTE: If the disc or other brake components require repairs or replacement, refer to Section 5.

#### Disassemble Wheel Hub Components (Fig. 57)

- a. Remove the oil seal and inner bearing cone from the hub using a brass drift and tapping with a hammer. Discard the oil seal.
  - b. Remove the inner and outer bearing cups using a brass drift and hammer.
6. Remove the spindle retaining bolts
  7. Remove the spindle and bronze thrust washer by tapping the end of the spindle lightly with a soft hammer to break it loose from the knuckle as shown in Figure 59. Discard the thrust washer if any wear has occurred.

#### Disassemble Spindle Components:

- a. Secure the spindle in a vise by locating on the high step diameter. Be sure that the machined surface of the spindle will not be damaged by the vise jaws.
  - b. Remove the oil seal.
  - c. Remove the needle roller bearing.
8. Remove the axle shaft and joint assembly.

#### Repair The Axle Joint Components:

- a. Remove the lock rings after removing pressure from the trunnion bearings by squeezing the ends of the bearing in a vise.
- b. Support the shaft yoke in a bench vise or on a short length of pipe.
- c. Using a brass drift and a soft hammer, drive on end of one trunnion bearing just far enough to drive opposite bearing from yoke.
- d. Support the other side of the yoke in the vise and drive the other bearing out by tapping on the end of the trunnion using a brass drift.
- e. Remove trunnion.
- f. Clean and inspect bearings. Lubricate with a high melting point type wheel bearing grease.
- g. Replace trunnion and press new or relubricated bearings into yoke and over trunnion hubs far enough to install lock rings.
- h. Hold trunnion in one hand and tap yoke lightly to seat bearings against lock rings.

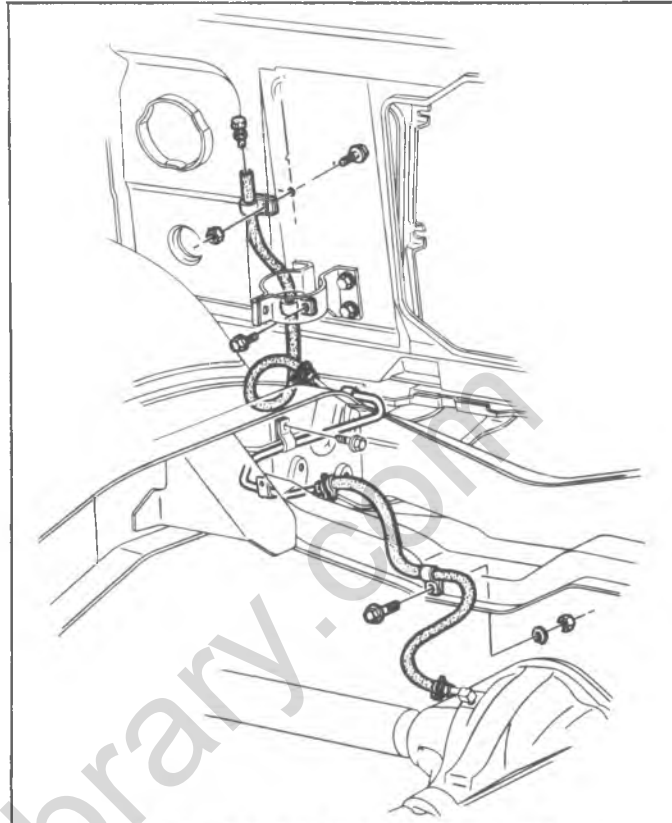

Fig. 56—Axle Vent Hose Routing - Typical

9. Remove axle slingers by placing into a vise and tapping off as shown in Figure 59 or using a press.

NOTE: If spindle seals will be replaced, also replace the axle shaft slingers.

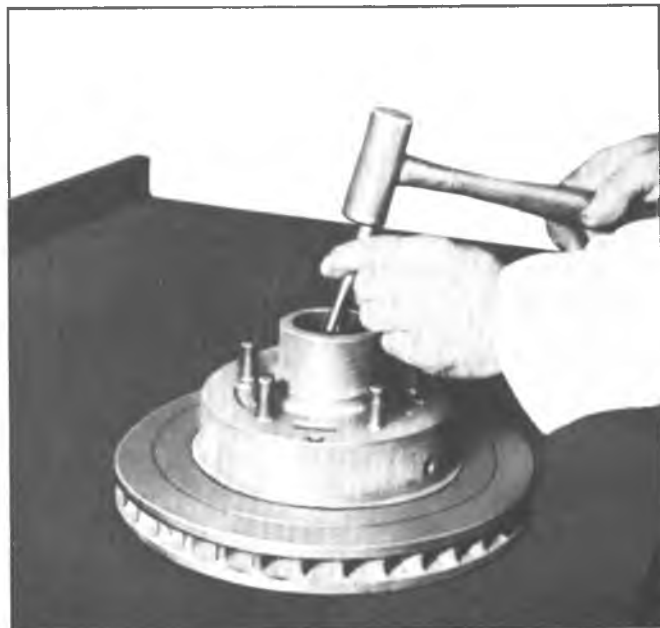

Fig. 57—Removing Bearing Cups

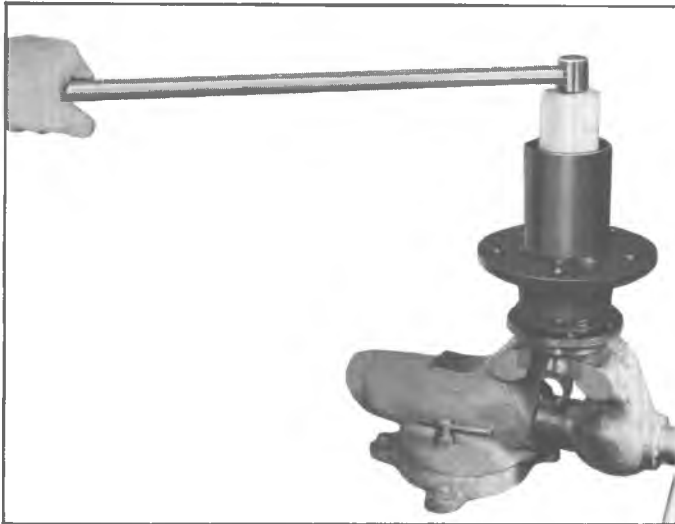

Fig. 58—Removing Wheel Bearings

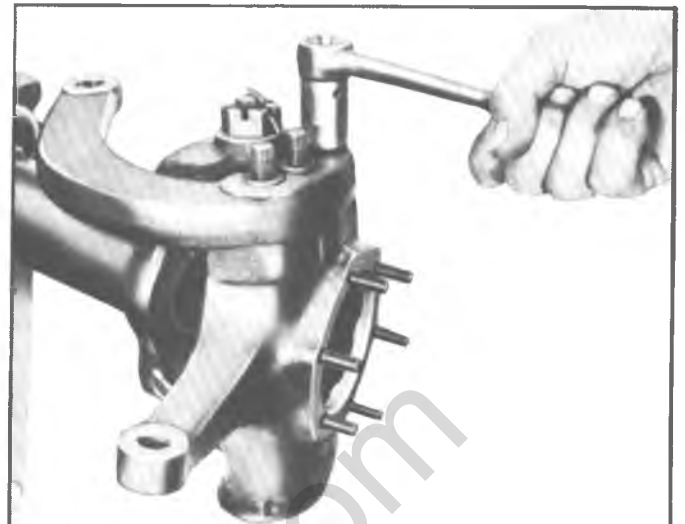

Fig. 61—Removing Steering Arm Nuts

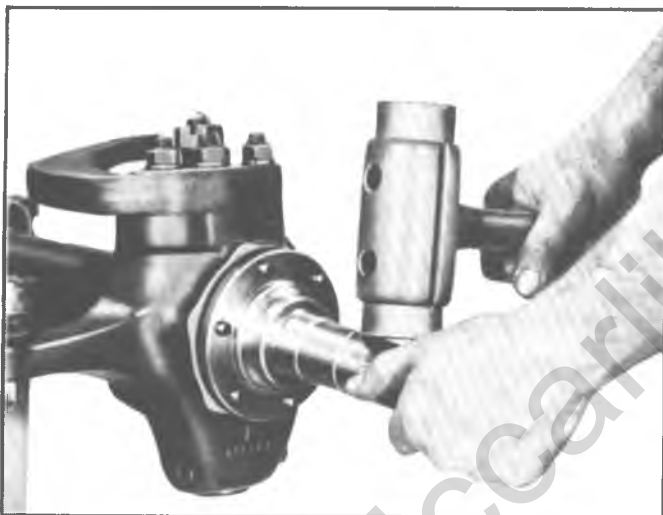

Fig. 59—Removing Spindle and Thrust Washer

10. To remove the tie rod:
  - a. Remove cotter pins.
  - b. Loosen tie rod nuts and tap on nut with a soft hammer to break the studs loose from the knuckle arm.
  - c. Remove nuts and disconnect the tie rod.

**CAUTION:** *If it is necessary to remove the steering arm, discard the three self-locking nuts (Fig. 61) and replace with new nuts at assembly.*

11. Remove the cotter pin from the upper ball socket nut.
12. Remove the retaining nuts from the upper and lower ball sockets as shown in Figure 62.
13. Remove the knuckle assembly from the yoke by inserting a suitable wedge-shaped tool between the

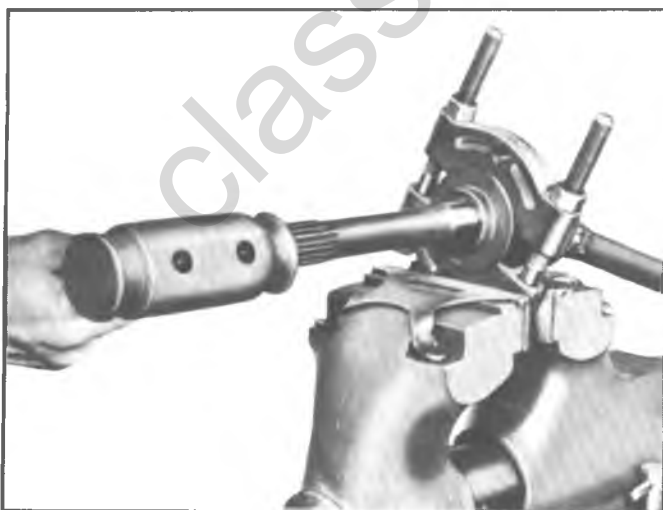

Fig. 60—Removing Axle Slingers

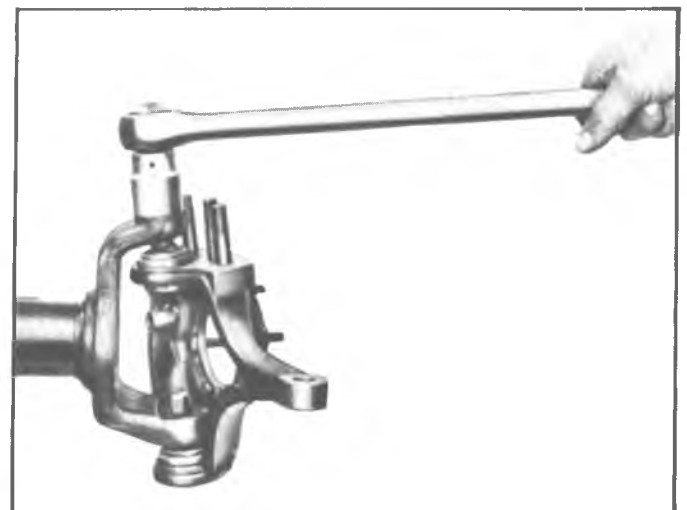

Fig. 62—Removing Ball Socket Retaining Nut

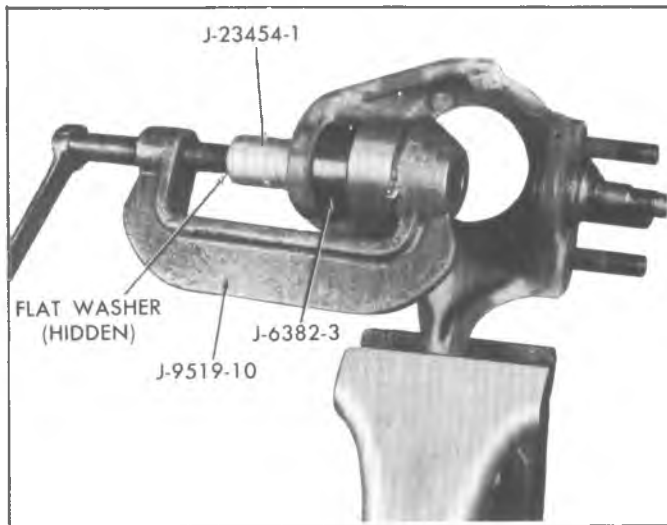

Fig. 63—Removing Lower Ball Joint

lower ball stud and the yoke and tapping on the tool to release the knuckle assembly. Repeat as required at the upper ball stud location.

**Ball Joint Service**

**CAUTION:** Do not remove the yoke upper ball stud adjusting sleeve unless new ball studs are being installed. If it is necessary to loosen the sleeve to remove the knuckle, do not loosen it more than two threads using Spanner J-23447 as shown in Figure 67. The nonhardened threads in the yoke can be easily damaged by the hardened threads in the adjusting sleeve if caution is not used during knuckle removal.

NOTE: Remove the lower ball joint snap ring before beginning.

NOTE: Lower ball joint must be removed

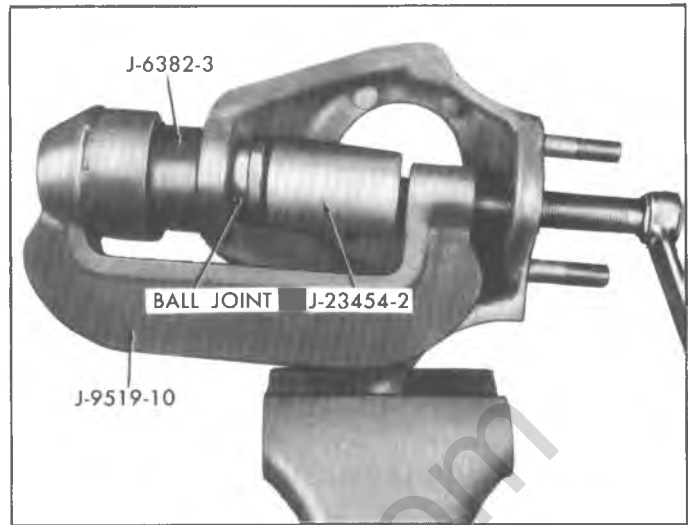

Fig. 65—Installing Lower Ball Joint

before any service can be performed on the upper ball joint.

14. Remove the lower ball joint using tools J-9519-10, J-23454-1, and sleeve J-6382-3 or equivalent as shown in Figure 63.

NOTE: Tool J-6382-3 is a previously released transmission tool. If this tool is not available, a suitable tool may be fabricated from 2 1/2" O.D. steel tubing with 3/16" wall thickness cut 2 1/2" long.

15. Remove the upper ball joint using tools J-9519-10, J-23454-1, and sleeve J-6382-3 or equivalent as shown in Figure 64.

**Assembly**

1. Install the lower ball joint into the knuckle. Make sure that the lower ball joint (the joint without



Fig. 64—Removing Upper Ball Joint

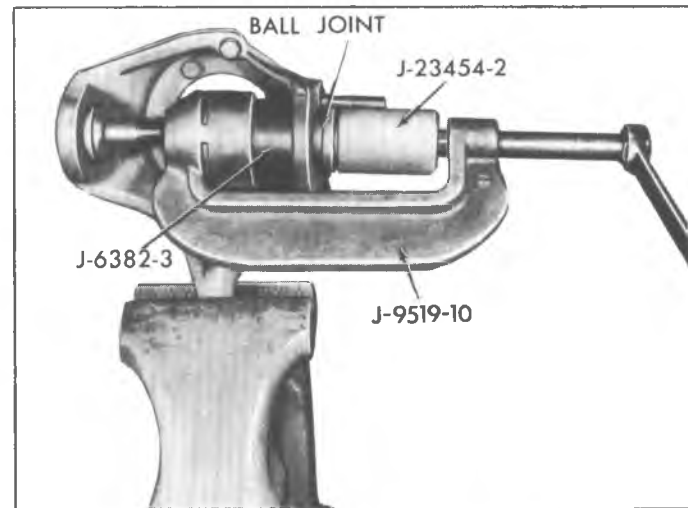

Fig. 66—Installing Upper Ball Joint



cotter pin hole in the stud end) is straight. Press the stud into the knuckle until properly seated using tools J-9519-10, J-23454-2, and J-6382-3 or equivalent as shown in Figure 64 and install snap ring.

2. Install the upper ball joint into the knuckle. Press the stud into the knuckle until properly seated using tools J-9519-10, J-23454-2, and J-6382-3 or equivalent as shown in Figure 66.
3. Position the knuckle and sockets to the yoke. Install new nuts finger tight to the upper (the nut with the cotter pin slot) and lower ball socket studs.
4. Push up on the knuckle (to keep the ball socket from turning in the knuckle) while tightening the lower socket retaining nut. Torque lower nut to 70 ft. lbs.
5. Torque the yoke upper ball stud adjusting sleeve to 50 ft. lbs. using Spanner J-23447.

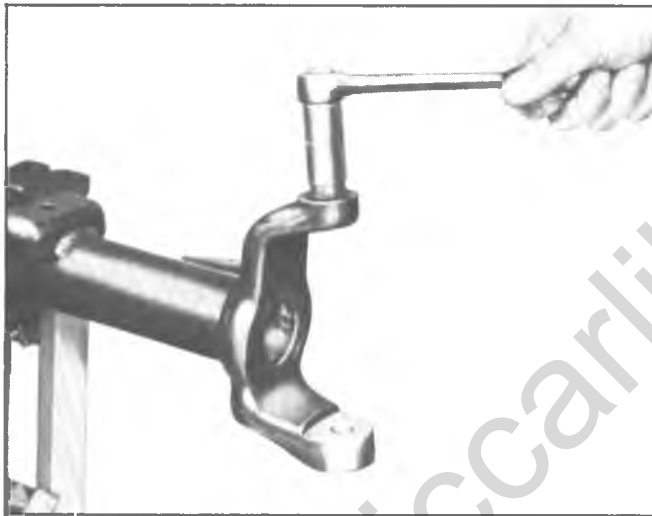

Fig. 67—Loosening Ball Stud Adjusting Sleeve

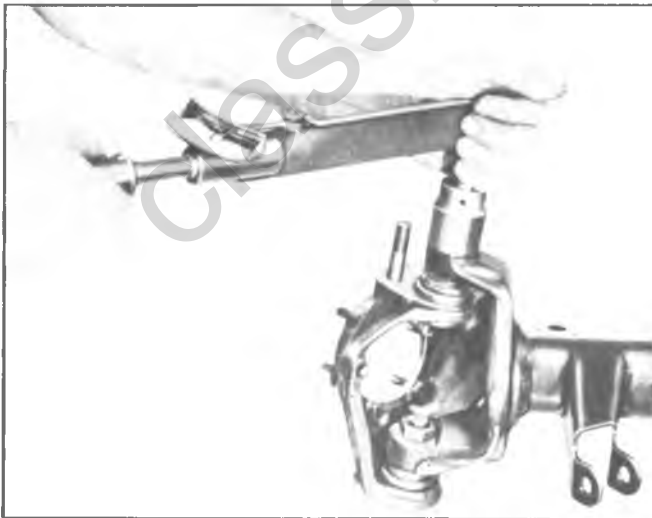

Fig. 68—Torquing Upper Ball Socket Nut

6. Torque the upper ball socket nut to 100 ft. lbs. as shown in Figure 68. After torquing the nut, do not loosen to install cotter pin, apply additional torque, if necessary, to line up hole in stud with slot in nut.

### Replacement of Knuckle Assembly

NOTE: In the event that knuckles are received with the sockets and snap ring assembled, along with the bottom torque prevailing nut, top castillation nut, split sleeve and cotter key, it is recommended that after all of the old parts are removed from the yoke, the steps listed below are to be followed for assembly of the knuckle to the yoke:

1. Assemble knuckle to yoke. Assemble bottom torque prevailing nut. Torque nut to 70-90 ft. lbs.

NOTE: If the stud turns while attempting to torque this nut, assemble the top nut and tighten till it is snug. This will pull the bottom stud into the tapered hole of the yoke and will prevent it from turning while torquing up the nut. After you have applied the 70-90 ft. lbs. Only use this method when necessary.

2. Remove the top nut.
3. Assemble Sleeve. Torque sleeve to 50 ft. lbs. using Spanner J-23447.
4. Assemble top nut. Torque nut to 100 ft. lbs. Tighten nut to line up the hole of the stud to the next castillation on slot of the nut.

NOTE: Do not loosen nut to install cotter pin, apply additional torque, if necessary, to line up hole in stud with slot in nut.

5. Assemble cotter key.
6. Assemble remaining wheel end parts.

### If Tie Rod and Steering Arm Were Removed:

- a. Assemble the steering arm using the three stud adapters and three new self-locking nuts. Torque the nuts to 90 ft. lbs.
- b. Assemble the tie rod to the knuckle arm. Torque the tie rod nuts to 45 ft. lbs. and install cotter pin.
7. Using the outer wheel bearing spindle nut as an installer, assemble the inner axle slinger (yoke side) to the shaft. Place spindle nut in a vise and the slinger over the end of the shaft. Tap on the end of the shaft with a soft hammer until the slinger is fully seated.
8. Assemble the outer axle slinger (spindle side) to the shaft using one of the wheel spindles as a starting guide.

NOTE: Do not use spindle as a pressing or driving tool. Also, use care not to damage spindle seal surface on slinger.

### 3-48 FRONT SUSPENSION

#### Assemble Spindle Components:

- a. Place the spindle in a vise on the high step and install needle roller bearing using Installer J-23445 and Drive Handle J-8092.
  - b. Install grease seal onto slinger with lip toward spindle.
  - c. Relubricate the needle bearing and the spindle end (Fig. 69) with a high melting point type wheel bearing grease.
9. Assemble axle shaft and joint assembly (see "To repair the axle joint components" on Page 3-) and install in housing.
  10. Install the bronze thrust washer over the axle shaft with the chamfer toward the slinger and install the spindle as shown in Figure 69.
  11. Assemble spindle to knuckle.

NOTE: Torque spindle nuts to 45 ft. lbs.

#### ASSEMBLE WHEEL HUB COMPONENTS

##### (Wheel Bearing Adjustment)

- a. Assemble the outer wheel bearing cup into the wheel hub using Installer J-6368 and Driver Handle J-8092.
  - b. Assemble the inner wheel bearing cup into the wheel hub using Installer J-23448 and Driver Handle J-8092.
  - c. Pack the wheel bearing cone with a high melting point type wheel bearing grease and insert the cone into the cup.
12. Install the disc and the outer wheel bearing cone to the spindle. Torque the inner adjusting nut to 50 ft.

lbs. (while rotating hub) to seat the bearings using Tool J-6893 and Adapter J-23446 or J-6893-01. Back off the inner adjusting nut and retorque to 35 ft. lbs. while the hub is being rotated.

13. Back off the inner adjusting nut again 3/8 turn maximum. Assemble lockwasher by turning nut to nearest hole in lockwasher. Install outer lock nut and torque to 50 ft. lbs. (minimum).

NOTE: Hub assembly should have .001 to .010 inch end play.

14. If vehicle is not equipped with free-wheeling hubs, install the hub cap assembly. If the vehicle is equipped with free-wheeling hubs, refer to free-wheeling hub assembly and installation procedures.

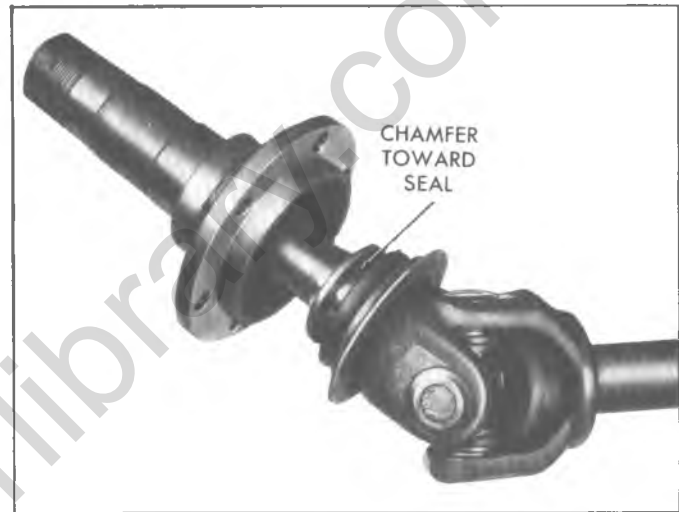

Fig. 69—Installing Spindle and Thrust Washer

## SPECIAL TOOLS



Fig. 70—Special Tools — 4 Wheel Drive

classiccarylbrary.com

**SECTION 4**

**REAR SUSPENSION AND DRIVELINE**

The following caution applies to one or more steps in the assembly procedure of components in this portion of the manual as indicated at appropriate locations by the terminology "See Caution on page 1 of this Section".

*CAUTION: THIS FASTENER IS AN IMPORTANT ATTACHING PART IN THAT IT COULD AFFECT THE PERFORMANCE OF VITAL COMPONENTS AND SYSTEMS, AND/OR COULD RESULT IN MAJOR REPAIR EXPENSE. IT MUST BE REPLACED WITH ONE OF THE SAME PART NUMBER OR WITH AN EQUIVALENT PART IF REPLACEMENT BECOMES NECESSARY. DO NOT USE A REPLACEMENT PART OF LESSER QUALITY OR SUBSTITUTE DESIGN. TORQUE VALUES MUST BE USED AS SPECIFIED DURING REASSEMBLY TO ASSURE PROPER RETENTION OF THIS PART.*

**CONTENTS OF THIS SECTION**

Rear Suspension.....	4-1
Propeller Shaft.....	4-8
Rear Axle.....	4-16

**REAR SUSPENSION**

**INDEX**

General Description.....	4-1
Component Parts Replacement.....	4-2
Shock Absorbers.....	4-2
Stabilizer Shaft.....	4-3
Leaf Spring Assembly.....	4-4
Shackles and Hangers.....	4-7
U-Bolts.....	4-7

**GENERAL DESCRIPTION**

All 10-30 series vehicles use a leaf spring/solid rear axle suspension system. Typical systems are illustrated in figures 1, 2 and 3.

The rear axle assembly is attached to multi-leaf springs by "U" bolts. The spring front eyes are attached to the frame at the front hangers, through rubber bushings. The rear ends of the springs are attached to the frame by the use of shackles which allow the spring to "change its length" while the vehicle is in motion. Control arms are not used with leaf springs.

Ride control is provided by two identical direct double acting shock absorbers angled-mounted between the frame and brackets attached to the axle tubes.

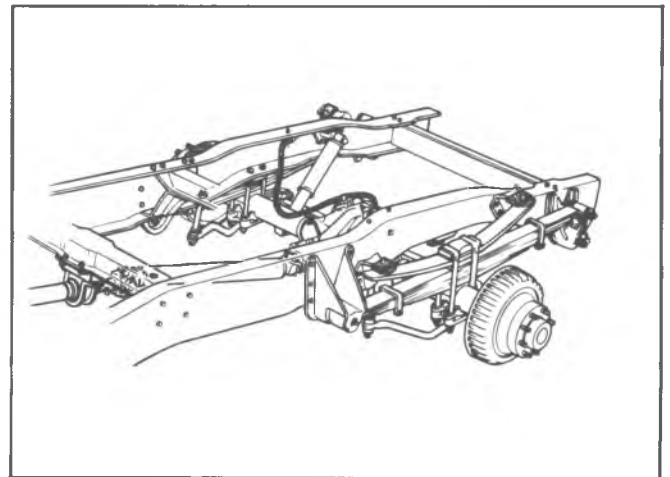

Fig. 1—Typical C-30 H.D. Truck Rear Suspension

## 4-2 REAR SUSPENSION AND DRIVELINE

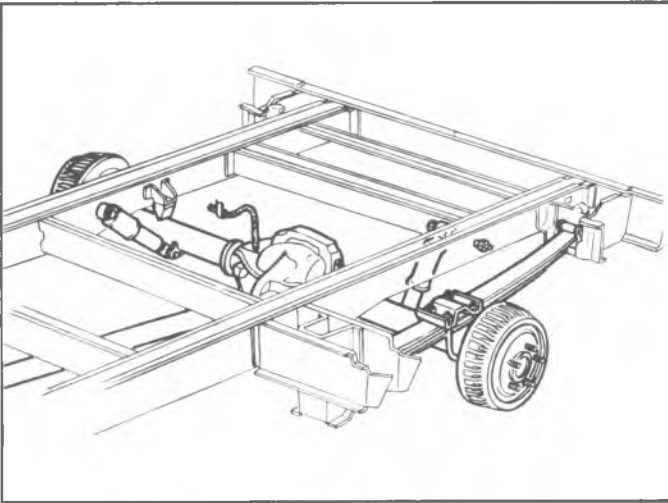

Fig. 2—Typical G-Truck Rear Suspension

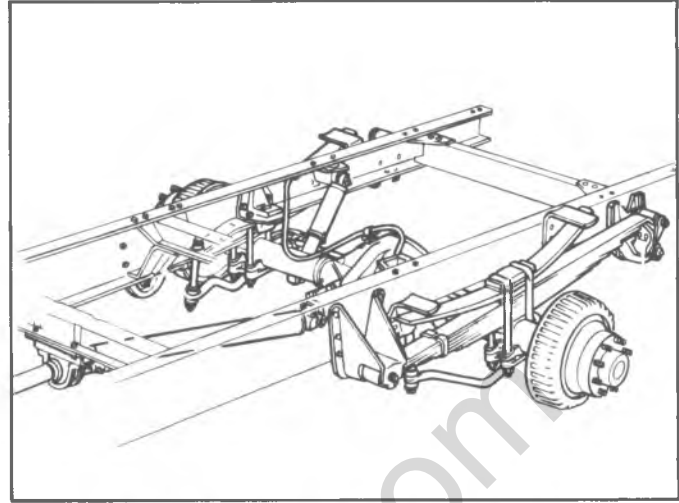

Fig. 3—Typical P-30 H.D. Truck Rear Suspension

## COMPONENT PARTS REPLACEMENT

### SHOCK ABSORBERS

#### Replacement

Refer to figures 4, 5, 6, 7 and 8 for specific vehicle mounting provisions.

1. Raise vehicle on hoist, and support rear axle.
2. If equipped with air lift shock absorbers, bleed air from lines. Disconnect line from shock absorber.
3. At the upper mounting location, disconnect shock absorber by removing nut and washers shown, and bolt on G-models.
4. At the lower mounting location, remove nut, washers and bolt as shown.

5. Remove shock absorber from vehicle.
6. To install shock absorber, place into position and reattach at upper mounting location. Be sure to install nuts and washers as shown.
7. Align lower end of shock absorber with axle bracket, and install bolt, washers and nut, as shown.
8. Tighten nuts to specifications.

**CAUTION:** See *CAUTION* on page 1 of this section, regarding shock absorber fasteners.

9. If equipped with airlift shock absorbers, inflate to 10-15 pounds minimum air pressure.
10. Lower vehicle and remove from hoist.

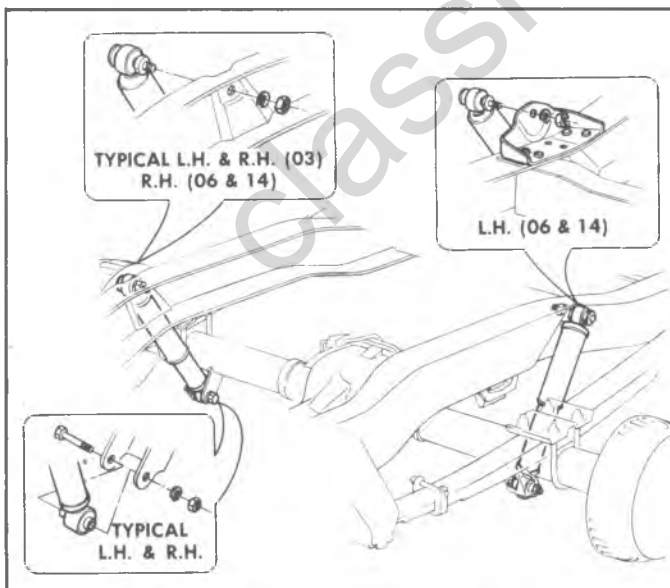

Fig. 4—Shock Absorber—CK-10, CK-20 (03, 06)

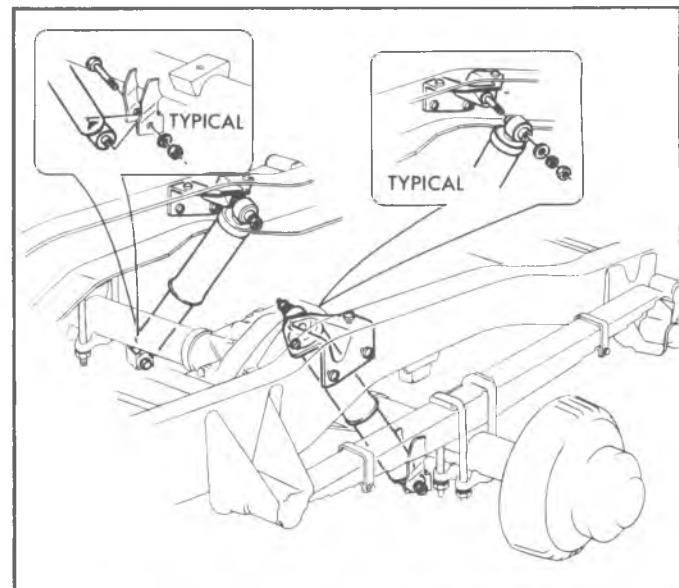

Fig. 5—Shock Absorber—CK-20 (63), C-30

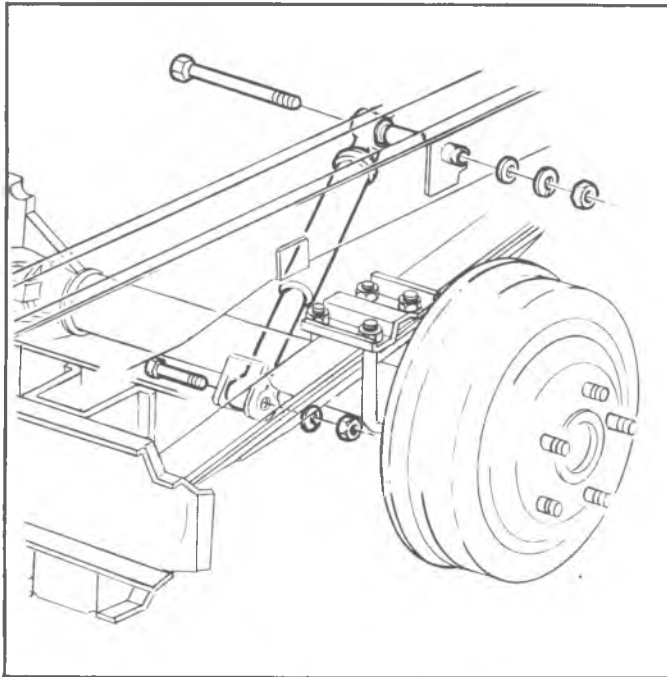

Fig. 6—Shock Absorber—G-10, 20, 30

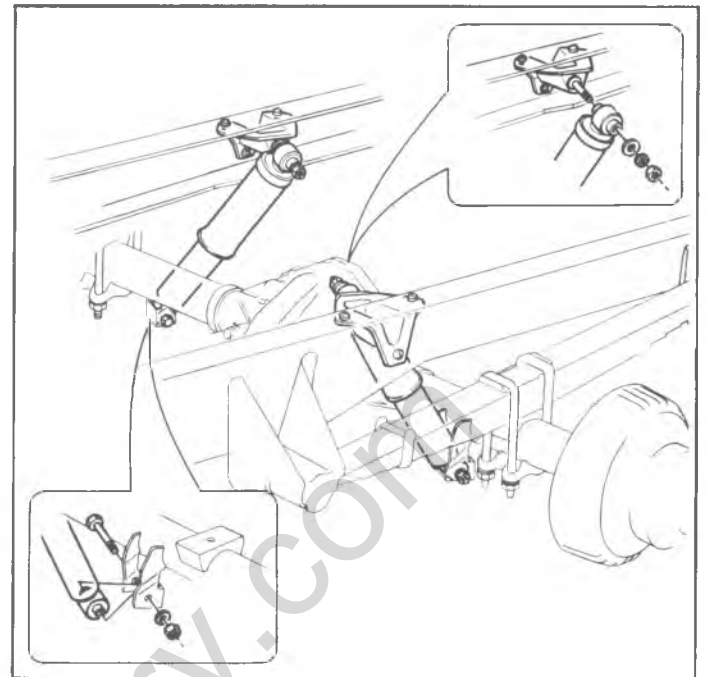

Fig. 8—Shock Absorber—P30

### STABILIZER SHAFTS

Refer to figures 9, 10 and 11 for specific rear stabilizer shaft mounting on C and P models.

#### Replacement

1. Raise vehicle on hoist and support rear axle.
2. Remove nut, washer and grommet from link bolt at the frame side member on each side.
3. Withdraw link bolt, washers, grommets and spacer.

4. Remove brackets from anchor plates by removing attaching screws.
5. Remove stabilizer shafts.
6. Reverse above steps to install stabilizer shaft. On installation, position shaft so parking brake cable is routed over stabilizer.
7. Torque all bolts to specifications.
8. Lower hoist and remove vehicle.

**CAUTION:** See *CAUTION* on page 1 of this section, regarding stabilizer fasteners.

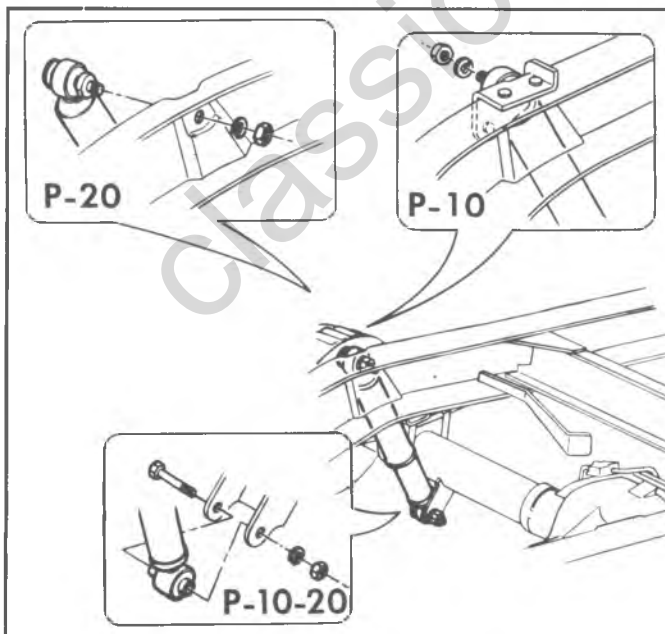

Fig. 7—Shock Absorber—P-10, 20

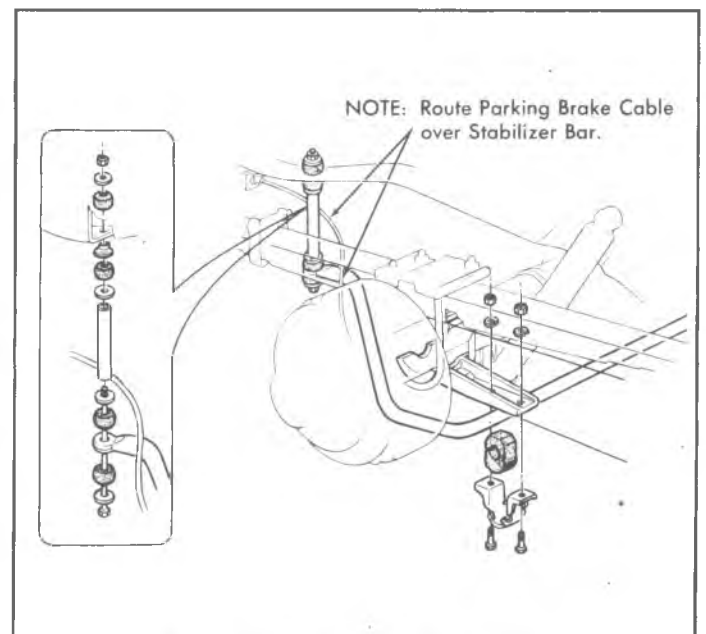

Fig. 9—Rear Stabilizer Shaft—C-20(03)

## 4-4 REAR SUSPENSION AND DRIVELINE

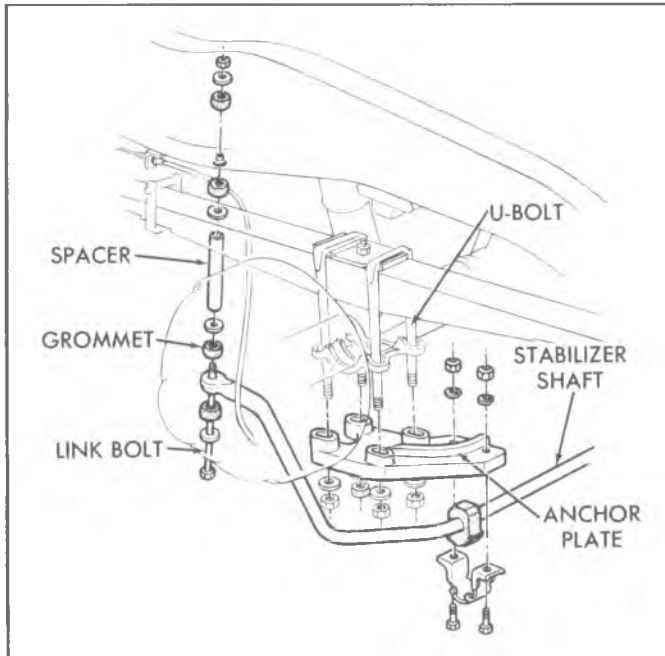

Fig. 10—Rear Stabilizer Shaft—C-20(63), C-30

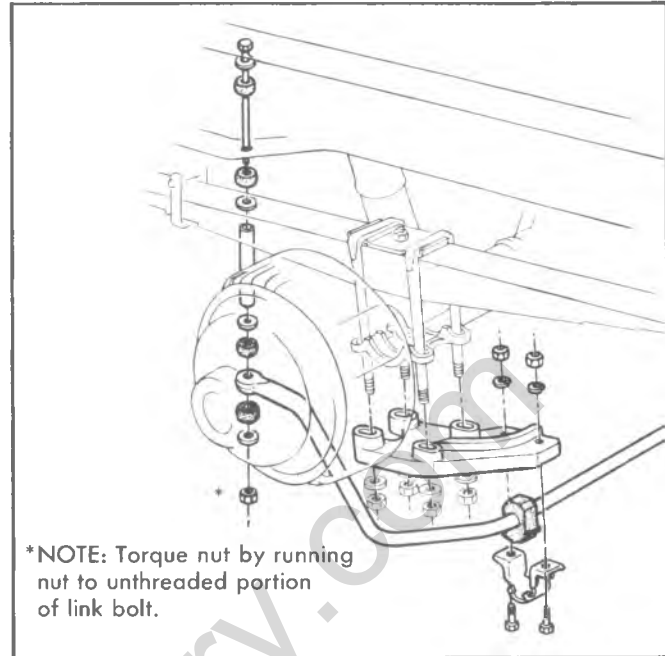

Fig. 11—Rear Stabilizer Shaft—P-30

### LEAF SPRING ASSEMBLY

Refer to figures 12, 13, 14 and 15 for specific leaf spring mounting provisions of C, K, G and P models. Figure 17 illustrates a typical U-bolt anchor plate installation with the mandatory tightening sequence.

**CAUTION:** See CAUTION on page 1 of this section, regarding leaf spring fasteners.

#### Removal

1. Raise vehicle on hoist so that tension in spring is relieved.

2. Loosen, but do not remove, spring-to-shackle retaining nut.
3. Remove nut and bolt securing shackle to spring hanger.
4. Remove nut and bolt securing spring to front hanger.
5. Remove "U" bolt retaining nuts, withdraw "U" bolts and spring plate from spring-to-axle housing attachment.
6. Withdraw spring from vehicle.
7. Inspect spring. Replace bushings, repair or replace spring unit as outlined in this section.

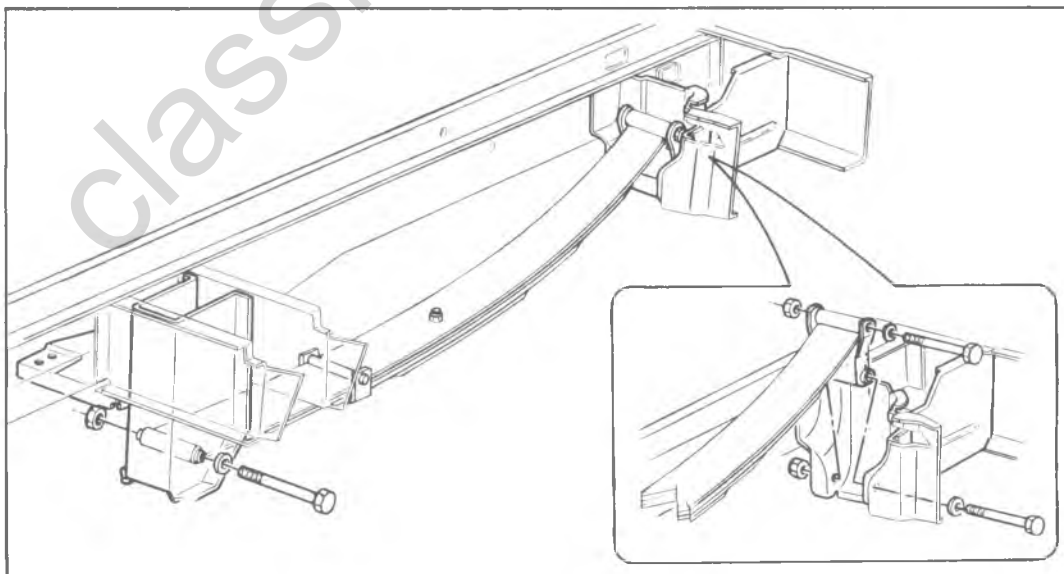

Fig. 12—Rear Spring Installation—G Models



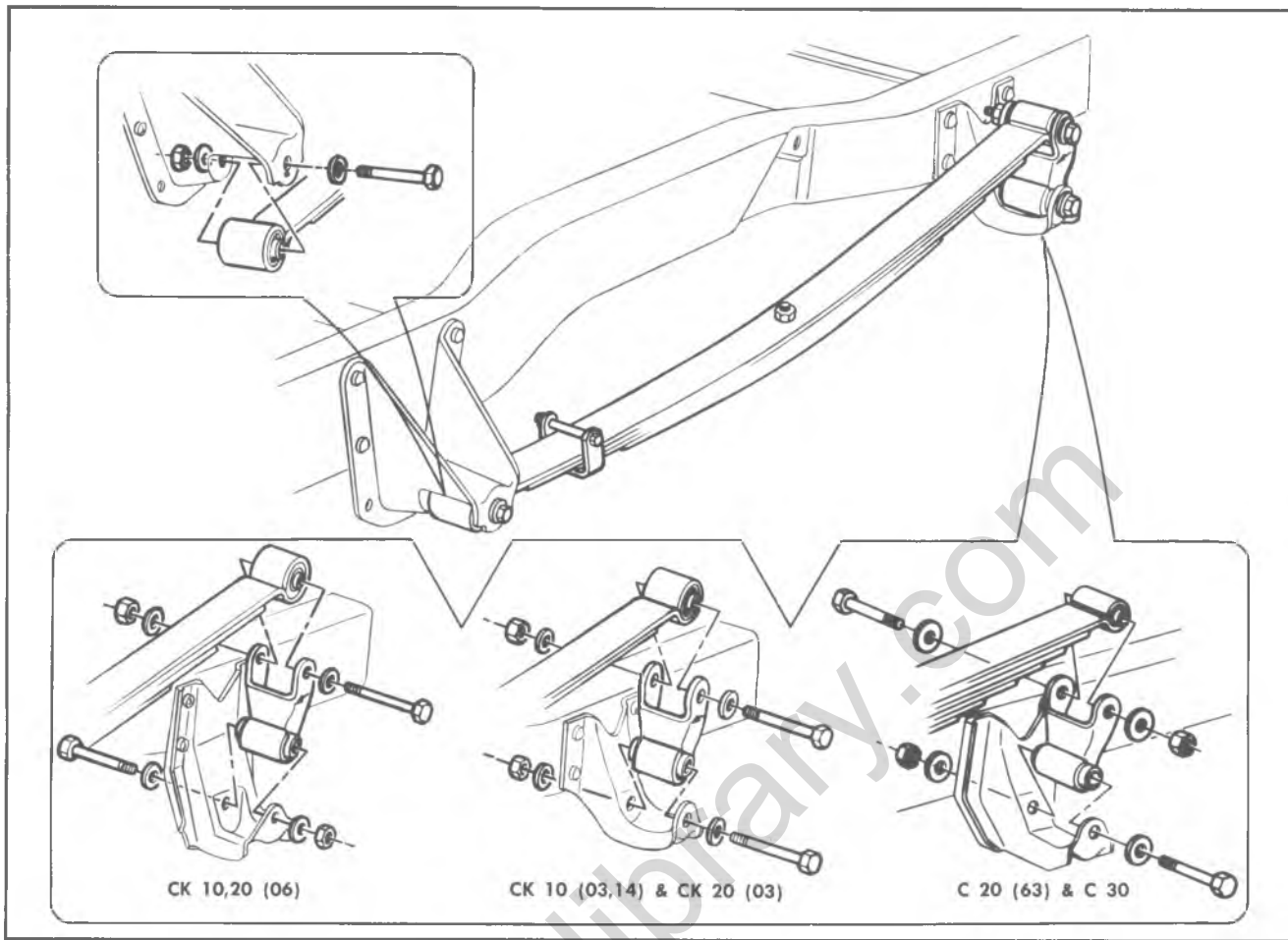

Fig. 13—Rear Spring Installation—C-K Models

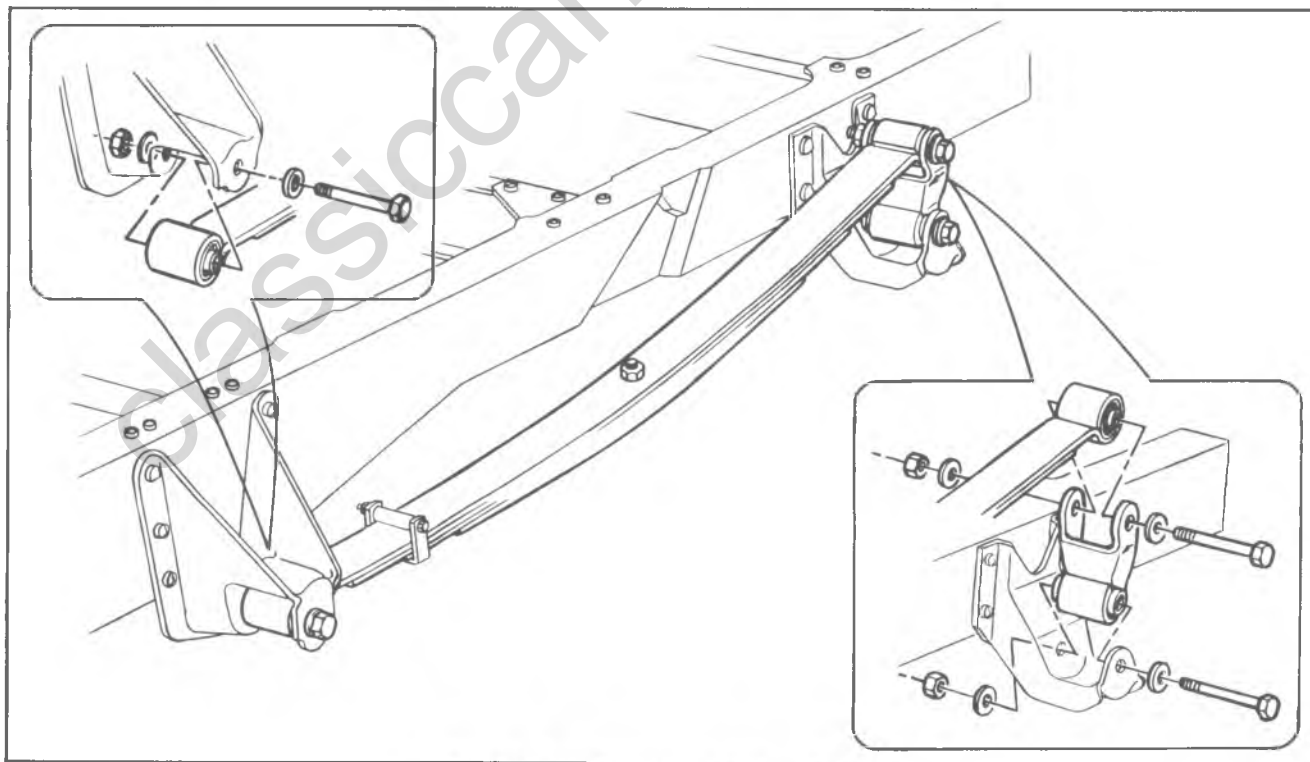

Fig. 14—Rear Spring Installation—P10,20

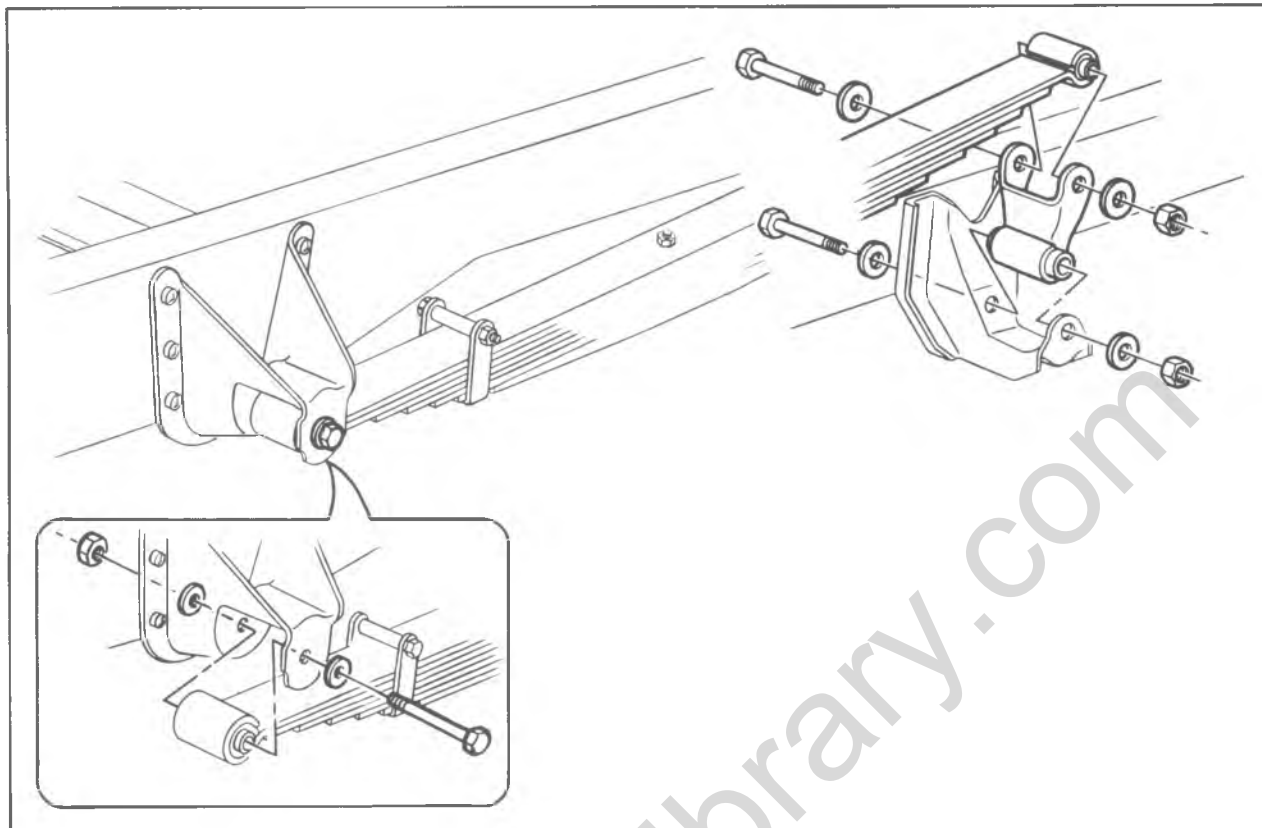

Fig. 15—Rear Spring Installation—P30

### Bushing Replacement

1. Place spring on press and press out bushing using a suitable rod, pipe or tool as shown in figure 16.
2. Press in new bushing; assure that tool presses on steel outer shell of bushing.

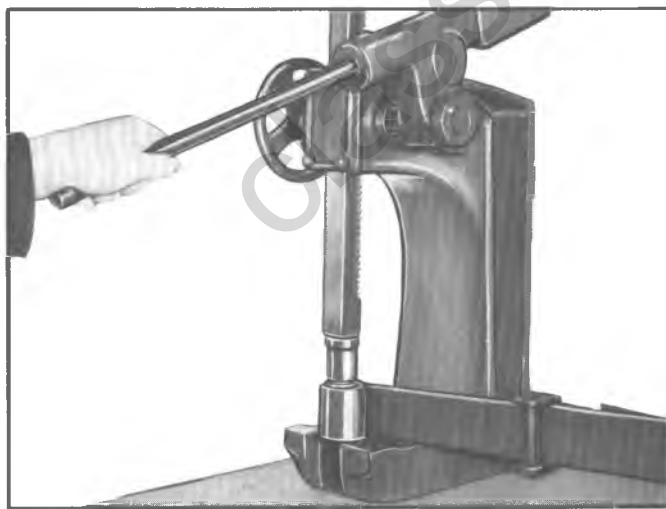

Fig. 16—Pressing Out Bushing

### Spring Leaf Replacement

1. Place spring assembly in a bench mounted vise and remove spring clips.
2. Position spring in vise jaws, compressing leaves at center and adjacent to center bolt.
3. File peened end of center bolt and remove nut. Open vise slowly to allow spring assembly to expand.
4. Wire brush and clean spring leaves. Inspect spring leaves to determine if replacement is required; also replace defective spring leaf liners at this time.
5. Align center holes in spring leaves by means of a long drift and compress spring leaves in a vise.
6. Remove drift from center hole and install a new center bolt. Peen bolt to retain nut.
7. Align spring leaves by tapping with hammer, then bend spring clips into place or install bolts and spacer if so equipped.

NOTE: Spring clips should be bent sufficiently to maintain alignment, but not tight enough to bind spring action.

### Leaf Spring Installation

1. Position spring assembly to axle. Make sure spring is in position at both spring hangers.

**NOTE:** The shackle assembly must be attached to the rear spring eye before installing shackle to rear hanger.

2. Install spring retainer plate and "U" bolts. Loosely install retaining nuts, but do not torque at this time.
3. Jack frame as required to align spring and shackle with spring hangers.
4. Install shackle bolt and nut and again reposition spring, if necessary to align front eye. Install front eye bolt and nut.
5. Lower vehicle so that weight of vehicle is on suspension components and torque affected suspension parts to specifications.
6. Lower vehicle and remove from hoist.

### U-Bolt and Anchor Plate Installation

Figure 17 illustrates the mandatory sequence of tightening U-bolt nuts. Tighten diagonally opposite nuts to 40-50 foot pounds, then tighten all nuts as shown to specifications.

**CAUTION:** See *CAUTION* on page 1 of this section, regarding "U"-Bolt fasteners.

### SHACKLE REPLACEMENT

1. Raise vehicle on hoist. Place adjustable lifting device under axle.
2. Remove load from spring by jacking frame.
3. Loosen spring-to-shackle retaining bolt, but do not remove.
4. Remove shackle-to-frame bracket retaining bolt—then remove shackle bolt from spring eye.
5. Position shackle to spring eye and loosely install retaining bolt—do not torque retaining bolt at this time.
6. Position shackle to frame bracket and install retaining bolt.
7. Rest vehicle weight on suspension components and torque both shackle bolt retaining nuts to specifications.

**CAUTION:** See *CAUTION* on page 1 of this section, regarding these fasteners.

8. Lower vehicle and remove from hoist.

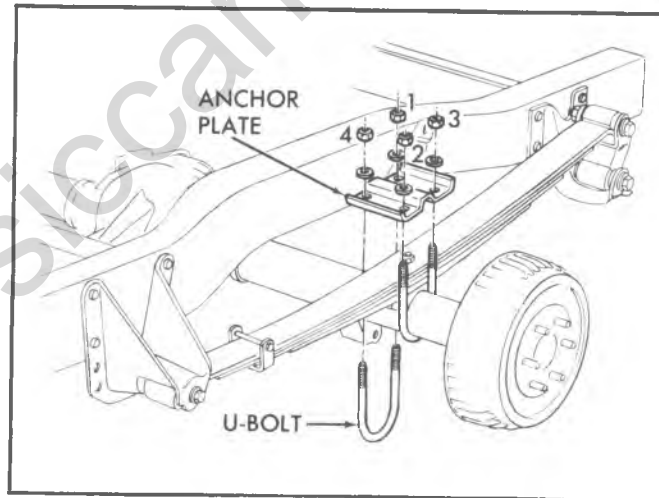

Fig. 17—Typical U-Bolt Installation

# PROPELLER SHAFT

## INDEX

Theory of Operation.....	4-8
Component Parts Replacement .....	4-9

### THEORY OF OPERATION

#### Universal Joints

The simple universal joint is basically two Y-shaped yokes connected by a crossmember called a spider. The spider is shaped like an X and arms that extend from it are called trunnions. See figure 18.

The spider allows the two yoke shafts to operate at an angle to each other. When torque is transmitted at an angle, through this type of joint, the driving yoke rotates at a constant speed while the driven yoke speeds up and slows down twice per revolution. This changing of velocity (acceleration) of the driven yoke increases as the angle between the two yoke shafts increases. This is the prime reason why single universal joints are not used for angles greater than three to four degrees. At four degrees, for example the change of velocity is .5%. At ten degrees it is 3%. If the universal joint were set at 30 degrees and the driving yoke were turning at 1000 RPM the velocity of the driven yoke would change from 856 RPM to 1155 RPM in one quarter of a revolution. In the remaining quarter revolution the velocity would change from 1155 RPM to 866 RPM.

On a one-piece drive shaft this problem can be eliminated by arranging two simple universal joints so that the two driving yokes are rotated 90 degrees to each other. However the angle between the drive and driven yokes must be very nearly the same on both joints for this to work. Refer to figure 19. This allows the alternate acceleration and deceleration of one joint to be offset by

the alternate deceleration and acceleration of the second joint. When the two joints do not run at approximately the same angle, operation can be rough and an objectionable vibration can be produced.

Universal joints are designed to consider the effects of various loadings and rear axle windup, during acceleration. Within the design angle variations the universal joints will operate safely and efficiently. However, when the design angles are exceeded the operational life of the joints may decrease.

The bearings used in universal joints are the needle roller type. The needle rollers are held in place on the trunnion by round bearing cups. The bearing cups are held in the yoke by either (depending on the manufacturer) snap rings or plastic injection. These joints usually are lubricated for life and cannot be lubricated while on the vehicle.

#### Constant Velocity Joint—Double Cardan Joint

As mentioned previously, the simple universal joint will operate efficiently through small angles only. Also, two simple universal joints phased properly and operating through the same angle will transmit constant velocity. When a large angle is encountered in a driveline, a simple universal joint will introduce two vibrations in each revolution. It is in this situation that a constant velocity joint is used.

Essentially, the constant velocity joint is two simple universal joints closely coupled by a coupling yoke, phased properly for constant velocity.

A centering ball socket between the joints maintains the relative position of the two units. This centering device causes each of the two units to operate through one-half of the complete angle between the drive shaft and differential carrier. See figure 20.

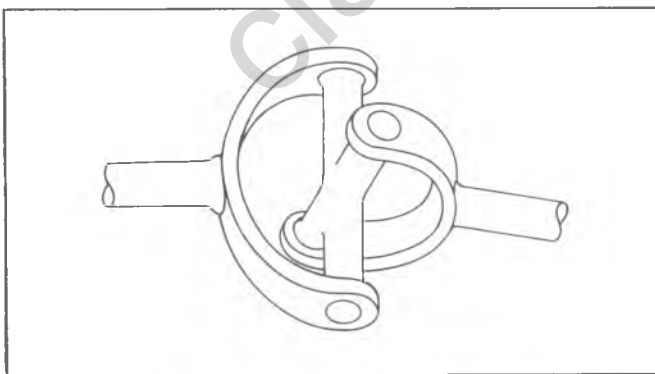

Fig. 18—Simple Universal Joint

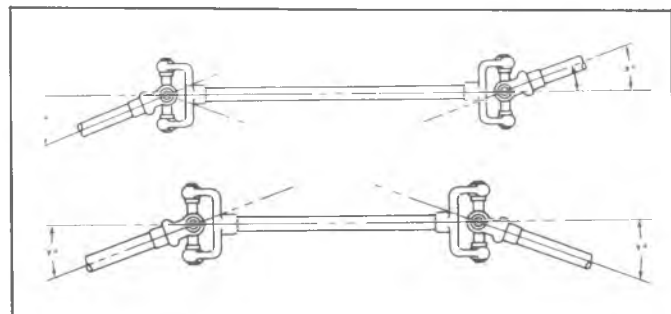

Fig. 19—Universal Joints Arranged for Constant Velocity

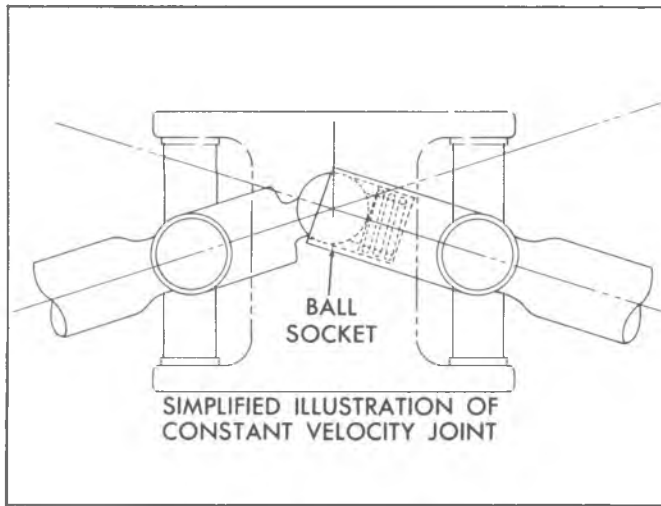

Fig. 20—Ball-Socket Location

NOTE: The ball/socket on this Constant Velocity joint requires periodic lubrication. A lubrication fitting is provided for this purpose, and is illustrated later in this section.

### Propeller Shafts

The propeller shaft is a steel tube which is used to transmit power from the transmission output shaft to the differential. To accommodate various model, wheelbase and transmission combinations, drive shafts differ in

length, diameter and the type of splined yoke. On some models the drive shaft is made up of concentric steel tubes with rubber elements between.

Each shaft is installed in the same manner. A universal joint and splined slip yoke are located at the transmission end of the shaft, where they are held in alignment by a bushing in the transmission rear extension. The slip yoke permits fore and aft movement of the drive shaft as the differential assembly moves up and down. The spline is lubricated internally by transmission lubricant or grease. An oil seal at the transmission prevents leakage and protects the slip yoke from dust, dirt and other harmful material.

Since the drive shaft is a balanced unit, it should be kept completely free of undercoating and other foreign material which would upset shaft balance.

### SERVICE INFORMATION

Both one piece and two piece propeller shafts are used depending on the model. All are tubular and use needle bearing type universal joints.

On models that use a two piece shaft, the shaft is supported near its splined end in a rubber cushioned ball bearing which is mounted in a bracket attached to a frame crossmember. The ball bearing is permanently lubricated and sealed.

Four wheel drive models use a front propeller shaft incorporating a constant velocity joint, shown in figure 30.

## COMPONENT PART REPLACEMENT

### PROPELLER SHAFT

Two methods are used to retain the propeller shaft to the

differential pinion flange. One method utilizes "U" bolts, and the other is a strap attachment. Refer to figures 21 and 22.

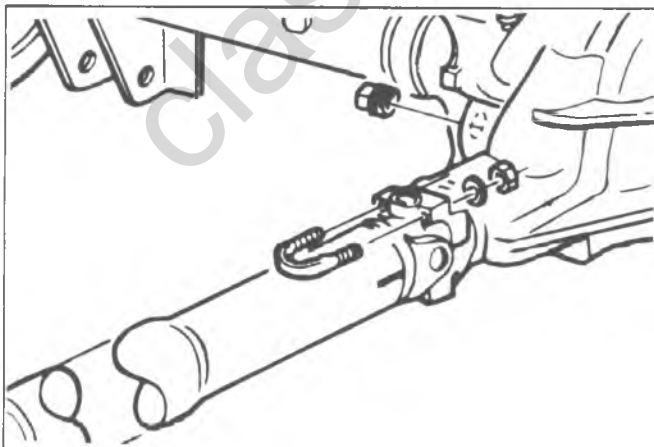

Fig. 21—U-Bolt Attachment

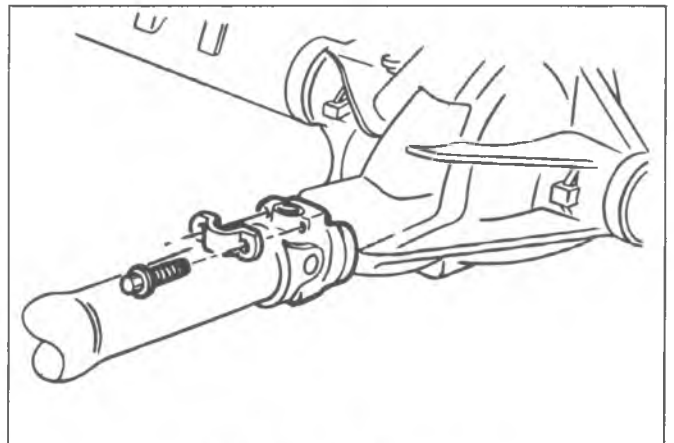

Fig. 22—Strap Attachment

## 4-10 REAR SUSPENSION AND DRIVELINE

### Removal

1. Raise vehicle on hoist. Mark relationship of shaft to companion flange and disconnect the rear universal joint by removing trunnion bearing "U" bolts or straps. Tape bearing cups to trunnion to prevent dropping and loss of bearing rollers.
2. For models with two-piece shafts remove bolts retaining bearing support to frame crossmember.
3. Slide propeller shaft forward disengaging trunnion from axle flange, then slide assembly rearward disengaging from transmission.

### Repairs (Universal Joints)

**NOTE:** The universal joints are of the extended-life design and do not require periodic inspection or lubrication; however, when these joints are disassembled, repack bearings and lubricate reservoir at end of trunnions with high-melting point wheel bearing lubricant and replace the dust seals.

1. Remove bearing lock rings from trunnion yoke.
2. Support trunnion yoke on a piece of 1-1/4" I.D. pipe on an arbor bed.

**NOTE:** Due to length of the propeller shaft it may be more convenient to use a bench vise, for removal and installation, instead of an arbor press. In this case, proceed with disassembly and assembly procedure as with an arbor press.

3. Using a suitable socket or rod, press on trunnion until bearing cup is almost out. Grasp cup in vise and work cup out of yoke.

**NOTE:** The bearing cup cannot be fully pressed out.

4. Press trunnion in opposite direction and remove other cup as in Step 3.

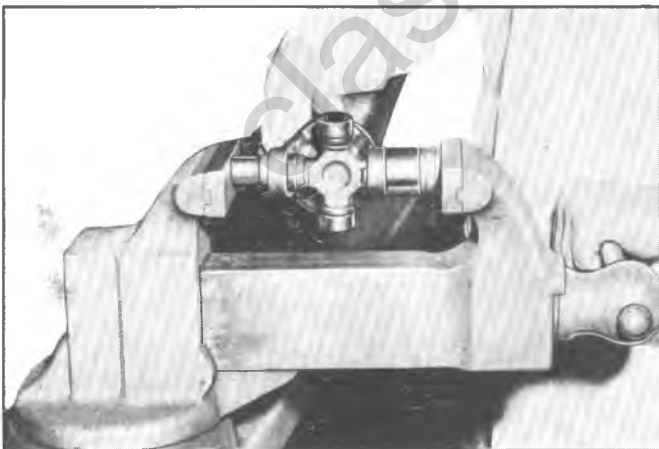

Fig. 23—Bearing Cup Removal with Vise

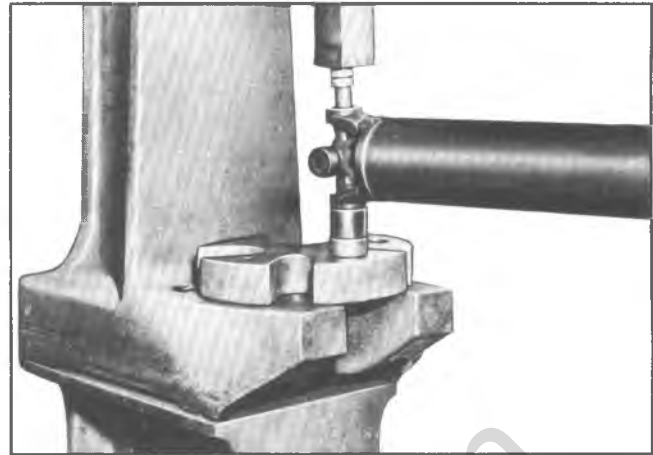

Fig. 24—Bearing Cup Removal with Press

5. Clean and inspect dust seals, bearing rollers, and trunnion. Relubricate bearings as indicated in Section 0.

**NOTE:** In addition to packing the bearings, make sure that the lubricant reservoir at the end of each trunnion is completely filled with lubricant. In filling these reservoirs, pack lubricant into the hole so as to fill from the bottom (use of squeeze bottle is recommended). This will prevent air pockets and ensure an adequate supply of lubricant.

6. If not installing a "U" joint service kit, as shown in figure 25, place dust seals on trunnions with the cavity of seal toward end of trunnion. Press seal onto trunnion exercising caution during installation to prevent seal distortion and to assure proper seating of seal on trunnion.

**NOTE:** If installing seal on small size trunnion, seal installer J-21548 should be used, shown in figure 26.

7. Position trunnion into yoke. Partially install one bearing cup into yoke. Start trunnion into bearing cup. Partially install other cup. Align trunnion into cup, and press cups into yoke. Install lock rings.

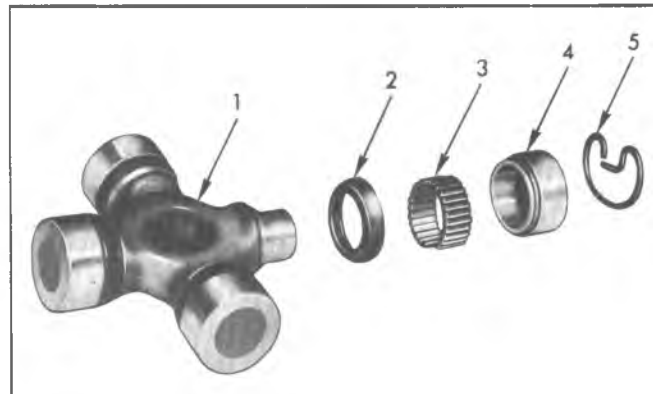

Fig. 25—Universal Joint Repair Kit

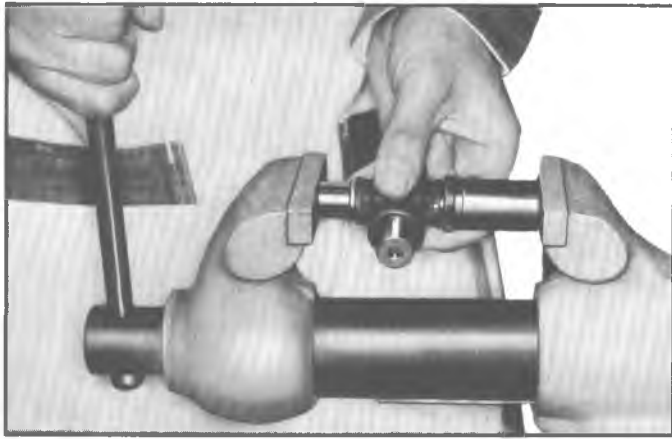

Fig. 26—Trunnion Seal Installer

### CENTER SUPPORT BEARING—FIG. 27

**CAUTION:** See *CAUTION* on page 1 of this section regarding Center Support Bearing fasteners.

1. Remove dust shield.
2. Remove strap retaining rubber cushion from bearing support.
3. Pull support bracket from rubber cushion and pull cushion from bearing.
4. Pull bearing assembly from shaft.
5. Assemble bearing support as follows:
  - a. Install inner deflector on propeller shaft, if removed, and prick punch deflector at two opposite points to make sure it is tight on shaft.
  - b. Fill space between inner dust shield and bearing with lithium soap grease.

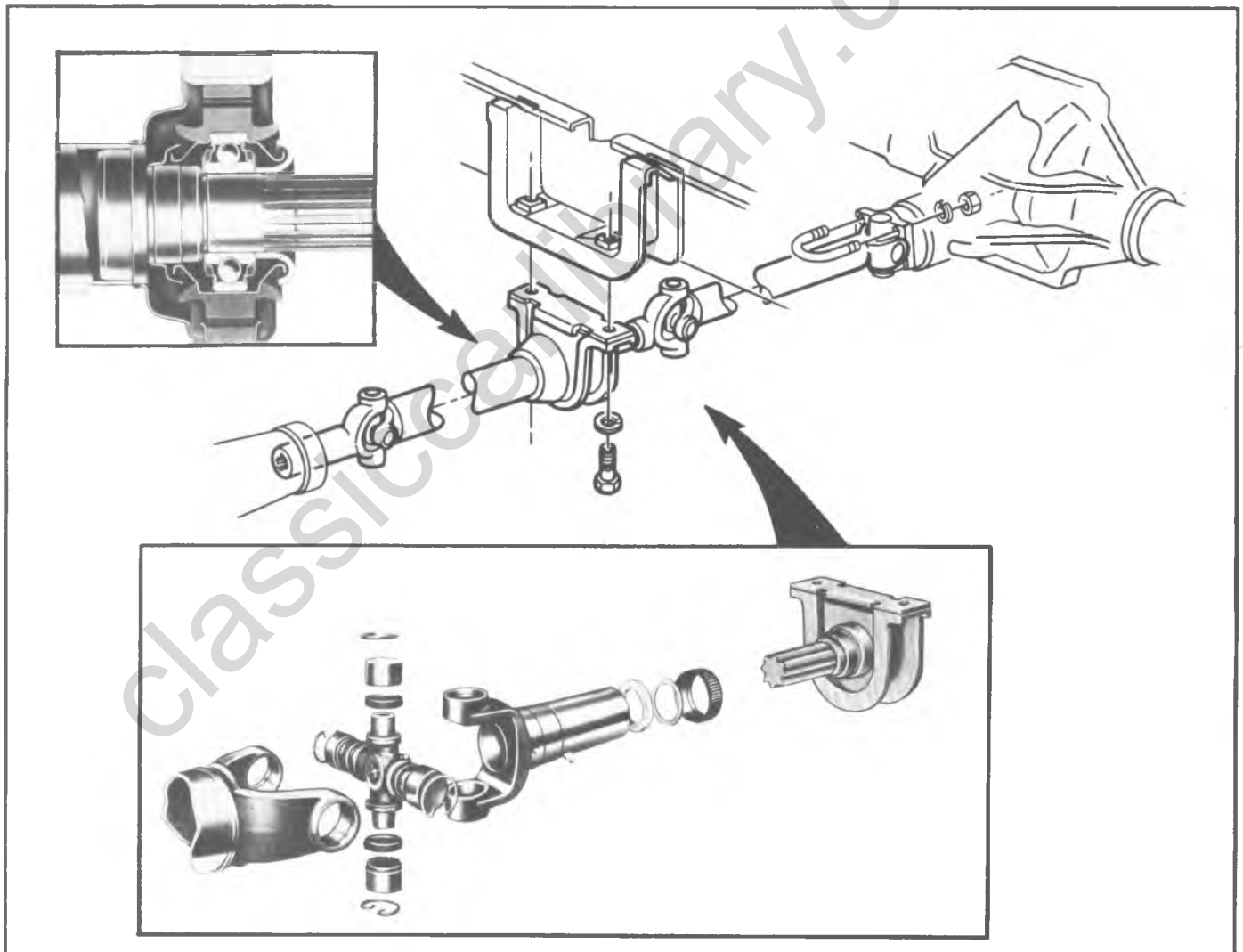

Fig. 27—Propeller Shaft, Universal Joint and Bearing Support

## 4-12 REAR SUSPENSION AND DRIVELINE

- c. Start bearing and slinger assembly straight on shaft journal. Support propeller shaft and, using suitable length of pipe over splined end of shaft, press bearing and inner slinger against shoulder on shaft.
- d. Install dust shield over shaft, small diameter first and press into position against outer slinger.
- e. Install rubber cushion onto bearing.
- f. Install bracket onto cushion.
- g. Install retaining strap.

### Installation

1. For models with one piece propeller shafts, slide shaft into transmission and attach rear U-joint axle. Torque bolts to specifications.
2. For C-P models with two-piece propeller shafts, proper phasing is accomplished with the alignment key, shown in figure 28.
3. For G-K models with two piece shafts, install front half into transmission and bolt support to crossmember.
  - a. Slide grease cap and gasket onto rear splines.
  - b. Rotate shaft so front U-joint trunnion is in a vertical position. See figure 29.
  - c. Take rear propeller shaft and before installing, align U-joint trunnions in same vertical position as in step b (at this point all U-joint trunnions

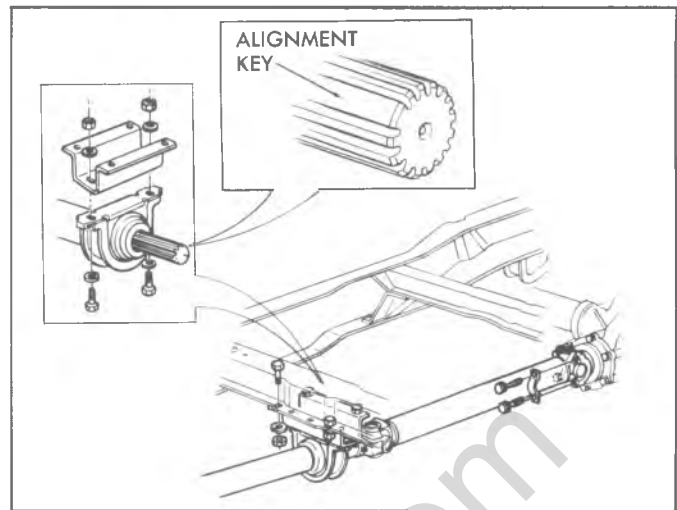

Fig. 28—C-P Propeller Shaft Alignment Key

should be vertical). Then, note relationship of front shaft and rear shaft spline position. Rotate rear shaft four splines toward left side of vehicle, and install rear shaft to front shaft. Attach rear U-joint to axle. Tighten grease cap.

- d. Torque bearing support to crossmember and U-joint to axle attachments to specifications.

## CONSTANT VELOCITY UNIVERSAL JOINT

### Disassembly

1. Remove front propeller shaft from vehicle.

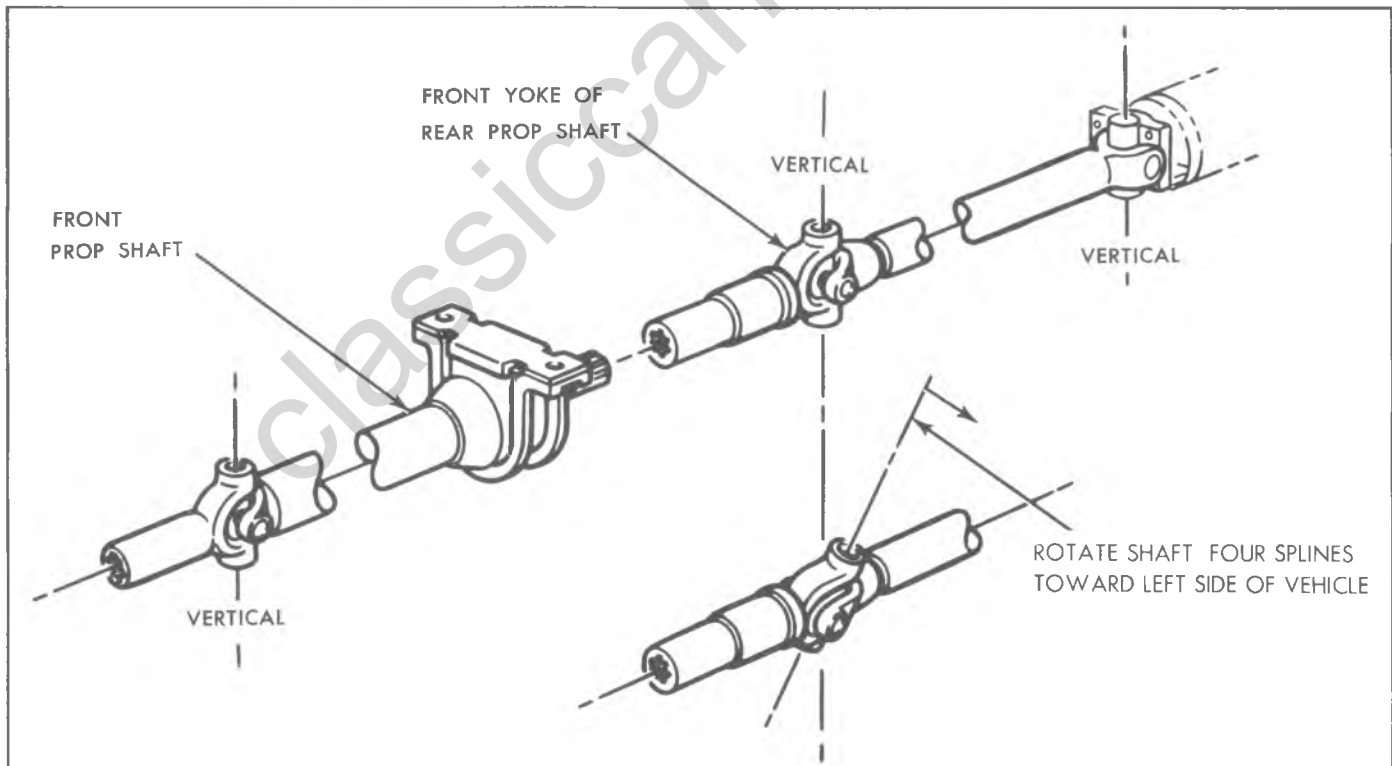

Fig. 29—Aligning U-Joints—G-K Models



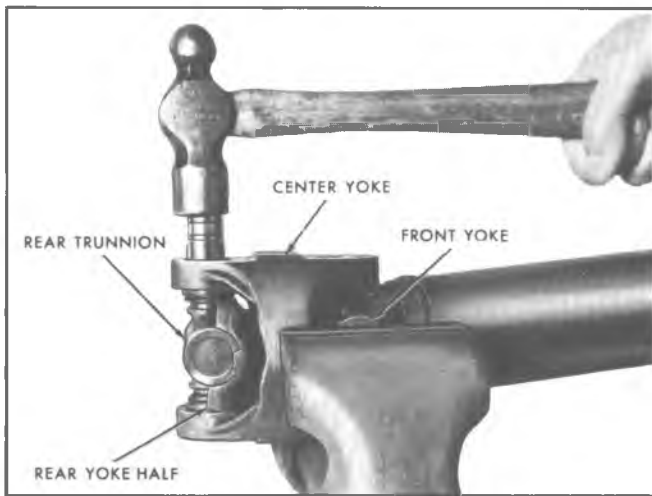

Fig. 30—Driving Out Bearing Cups

2. Remove rear trunnion snap rings from center yoke. Remove grease fitting.
3. Place propeller shaft in vice as shown in figure 30. Drive one rear trunnion bearing cap from center yoke as shown in figure 30 until it protrudes approximately 3/8".
4. Once the bearing cup protrudes 3/8", release vice. Grasp protruding portion of cup in vice and strike center yoke as shown in Figure 31 until cup is removed. Remove cup seal by prying off with a thin screwdriver.
5. Repeat steps 3 and 4 for remaining bearing cup.
6. Once the center yoke cups have been removed, remove rear yoke half bearing cups. Remove rear trunnion.
7. Gently pull rear yoke half from prop shaft. Remove all loose needle bearings. Remove spring seal.

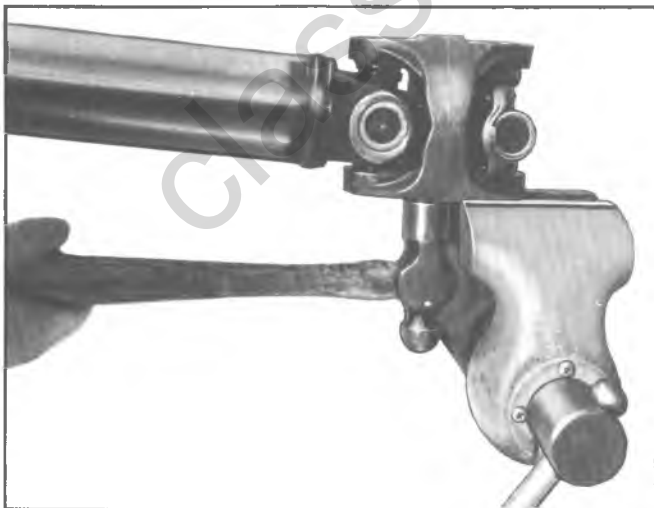

Fig. 31—Bearing Cup Removal

8. Remove front trunnion from center and front yoke in same manner as described in Steps 2, 3 and 4.

NOTE: Before front trunnion can be removed all four (4) bearing caps must be removed.

#### Assembly

1. Clean and inspect all needle bearings, cups, seals, fittings, trunnions and yokes. Assemble all needle bearings in caps (27 per cap); assemble needle bearings in front yoke (28 total). Retain bearings with a heavy grease. Assemble seals to bearing cups.
2. Place front trunnion in drive shaft. Place center yoke on front trunnion. Install one bearing cup and seal assembly in front yoke. Drive in to a depth that the snap ring can be installed. Install snap ring. Install remaining cup and seal in front yoke. Install snap ring.
3. Install front trunnion bearing cups in center yoke in same manner.
4. With front trunnion completely installed, install seal on prop shaft (large face first). Gently slip rear yoke half on prop shaft using care not to upset rollers. Insert rear trunnion in center yoke. Install rear yoke half bearing caps on rear trunnion. Install one rear trunnion bearing cap in center yoke and press into yoke until snap ring can be installed. Install remaining cap and snap ring.
5. Grease universal as outlined in Section 0 at all three (3) fittings (2 conventional type and one in rear yoke half) that requires a needle nose grease gun adapter.
6. Install propeller shaft with constant velocity joint next to transfer case. Torque U-bolts to specifications. The lubrication fitting at this location is shown in figure 32.

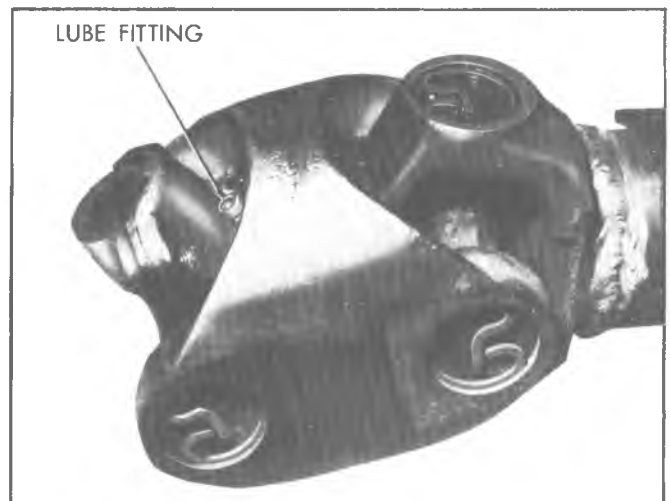

Fig. 32—Lubrication Fitting

## PROPELLER SHAFT AND UNIVERSAL JOINT DIAGNOSIS

### Checking and Correcting Propeller Shaft Unbalance—Vehicles with 8-7/8" Ring Gear Differentials Only

1. Place vehicle on a twin post hoist so that the rear wheels are free to rotate.
2. Remove both rear tire and wheel assemblies and brake drums.

**CAUTION:** Use care not to apply brakes with drums removed.

3. With vehicle running in gear at the indicated speed where disturbance is at its peak, observe the intensity of the disturbance.

4. Stop engine and check for any mud or undercoating on the propeller shaft. If any is found, remove it and again check the intensity of the vibration. If vibration is still present, proceed to step 5.
5. Bring indicated speed up to the point where disturbance was at its peak on the road test and observe the intensity of the disturbance. Stop engine and disconnect drive shaft from companion flange. Reinstall shaft by rotating it 180° from its original position. Determine which position of the companion flange gives the best balance.
6. Install rear drums and wheels, and road test vehicle for final check of balance. If balance is still unacceptable, replace drive shaft.

### DIAGNOSTIC CHART

COMPLAINT	POSSIBLE CAUSE	CORRECTION
Leak at front slip yoke.  <div style="border: 1px solid black; padding: 5px; width: fit-content;">                         NOTE: An occasional drop of lubricant leaking from splined yoke is normal and requires no attention.                     </div>	<ol style="list-style-type: none"> <li>a. Rough outside surface on splined yoke.</li> <li>b. Defective transmission rear oil seal.</li> </ol>	<ol style="list-style-type: none"> <li>a. Replace seal if cut by burrs on yoke. Minor burrs can be smoothed by careful use of crocus cloth or honing with a fine stone. Replace yoke if outside surface is rough or burred badly.</li> <li>b. Replace transmission rear oil seal.</li> <li>c. Bring transmission oil up to proper level after correction.</li> </ol>
Knock in drive line, clunking noise when car is operated under floating condition at 10 mph in high gear or neutral.	<ol style="list-style-type: none"> <li>a. Worn or damaged universal joints.</li> <li>b. Side gear hub counterbore in differential worn oversize.</li> </ol>	<ol style="list-style-type: none"> <li>a. Disassemble universal joints, inspect and replace worn or damaged parts.</li> <li>b. Replace differential case and/or side gears as required.</li> </ol>
Ping, Snap or Click in drive line.  <div style="border: 1px solid black; padding: 5px; width: fit-content;">                         NOTE: Usually occurs on initial load application after transmission has been put into gear, either forward or reverse.                     </div>	<ol style="list-style-type: none"> <li>a. Loose upper or lower control arm bushing bolts.</li> <li>b. Loose companion flange.</li> </ol>	<ol style="list-style-type: none"> <li>a. Tighten bolts to specified torque.</li> <li>b. Remove companion flange, turn 180° from its original position, apply white lead to splines and reinstall. Tighten pinion nut to specified torque.</li> </ol>

Fig. 33A—Diagnosis Chart A

COMPLAINT	POSSIBLE CAUSE	CORRECTION
<p>Roughness, Vibration or Body Boom at any speed.</p> <div style="border: 1px solid black; padding: 5px; margin-top: 10px;"> <p>NOTE: With tachometer installed in car, determine whether propeller shaft is cause of complaint by driving through speed range and note the engine speed (rpm) at which vibration (roughness) is most pronounced. Then, shift transmission to a different gear range and drive car at same engine speed (rpm) at which vibration was noted before. Note the effect on the vibration.</p> <p>If vibration occurs at the same engine speed (rpm), regardless of transmission gear range selected, drive shaft assembly is <u>not</u> at fault, since the shaft speed (rpm) varies.</p> <p>If vibration decreased, or is eliminated, in a different gear range but at the same engine speed (rpm), check the possible causes:</p> </div>	<ul style="list-style-type: none"> <li>a. Bent or dented drive shaft.</li> <li>b. Undercoating on drive shaft.</li> <li>c. Tire unbalance. (30-80 mph, not throttle conscious)</li> <li>d. Excessive U-bolt torque.</li> <li>e. Tight universal joints.</li> <li>f. Worn universal joints.</li> <li>g. Burrs or gouges on companion flange. Check snap ring locating surfaces on flange yoke.</li> <li>h. Drive shaft or companion flange unbalance.</li> <li>i. Excessive looseness at slip yoke spline.</li> <li>j. Drive shaft runout (50-80 mph throttle conscious)</li> </ul>	<ul style="list-style-type: none"> <li>a. Replace.</li> <li>b. Clean drive shaft.</li> <li>c. Balance or replace as required.</li> <li>d. Check and correct to specified torque.</li> <li>e. Impact yokes with a hammer to free up. Overhaul joint if unable to free up or if joint feels rough when rotated by hand.</li> <li>f. Overhaul, replacing necessary parts.</li> <li>g. Rework or replace companion flange.</li> <li>h. Check for missing balance weights on drive shaft. Remove and reassemble drive shaft to companion flange, 180° from original position.</li> <li>i. Replace necessary parts.</li> <li>j. Check drive shaft runout at front and rear. Should be less than specified. If above, rotate shaft 180° and recheck. If still above specified, replace shaft.</li> </ul>
<p>Roughness usually at low speeds, light load, 15-35 mph.</p>	<ul style="list-style-type: none"> <li>a. U-bolt clamp nuts excessively tight.</li> </ul>	<ul style="list-style-type: none"> <li>a. Check and correct torque to that specified. If torque was excessive or if brenelled pattern on trunnions is evident, replace joints.</li> </ul>
<p>Scraping noise.</p>	<ul style="list-style-type: none"> <li>a. Slinger, companion flange, or end yoke rubbing on rear axle carrier.</li> </ul>	<ul style="list-style-type: none"> <li>a. Straighten slinger to remove interference.</li> </ul>
<p>Roughness on heavy acceleration (short duration.)</p>	<ul style="list-style-type: none"> <li>a. Double cardan joint ball seats worn. Ball seat spring may be broken.</li> </ul>	<ul style="list-style-type: none"> <li>a. Replace joint and shaft assembly.</li> </ul>
<p>Roughness -- above 35 mph felt and/or heard.</p>	<ul style="list-style-type: none"> <li>a. Tires unbalanced or worn.</li> </ul>	<ul style="list-style-type: none"> <li>a. Balance or replace as required.</li> </ul>

Fig. 33B—Diagnosis Chart B

# REAR AXLE

## INDEX

General Description .....	4-16
Theory of Operation .....	4-21
Component Parts Replacement .....	4-26
8-7/8" Ring Gear Axle .....	4-26
Chevrolet 10-1/2" Ring Gear Axle .....	4-30
Dana 10-1/2" Ring Gear Axle .....	4-33
Dana 9-3/4" Ring Gear Axle .....	4-33
Chevrolet 12-1/4" Ring Gear Axle .....	4-33

### GENERAL DESCRIPTION

Five distinct axles comprise the truck line-up. These five, categorized by ring gear diameter, are a) 8-7/8" Ring Gear, b) Chevrolet 10-1/2" Ring Gear, c) Dana 10-1/2" Ring Gear, d) Dana 9-3/4" Ring Gear and e) Chevrolet 12-1/4" Ring Gear.

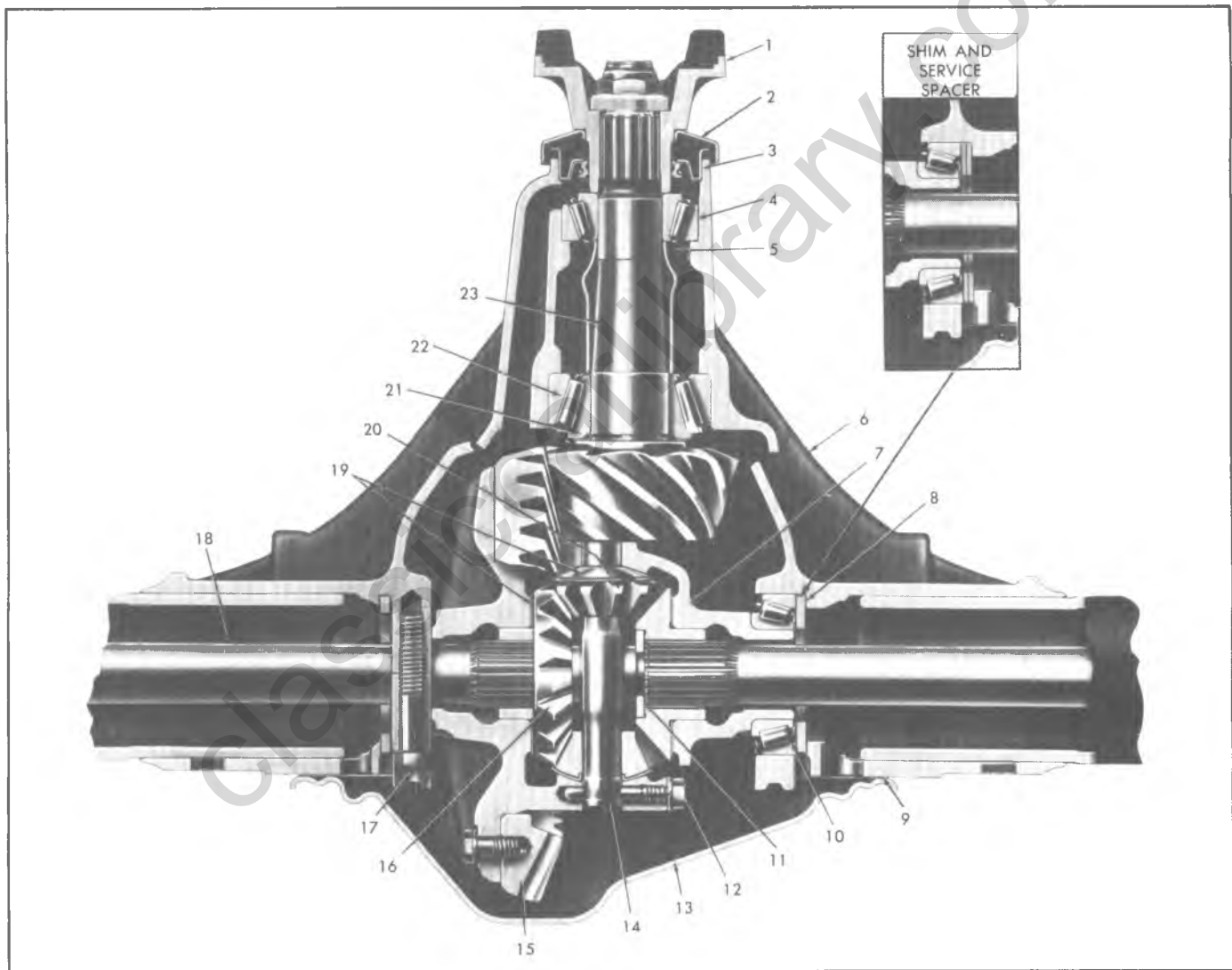

Fig. 34—8-7/8" Ring Gear Axle Cross-Section

### 8 7/8" Ring Gear Axle

The axle shown in figure 34 is a semifloating, fabricated constructed type consisting of a cast carrier with large bosses on each end into which two welded steel tubes are fitted. The carrier contains an overhung hypoid pinion

and ring gear. The differential is a two pinion arrangement.

The axle housing is made up of two steel welded tubes pressed into the crossbore of the cast carrier. Each tube is puddle welded to the carrier. Welded-on brackets provide

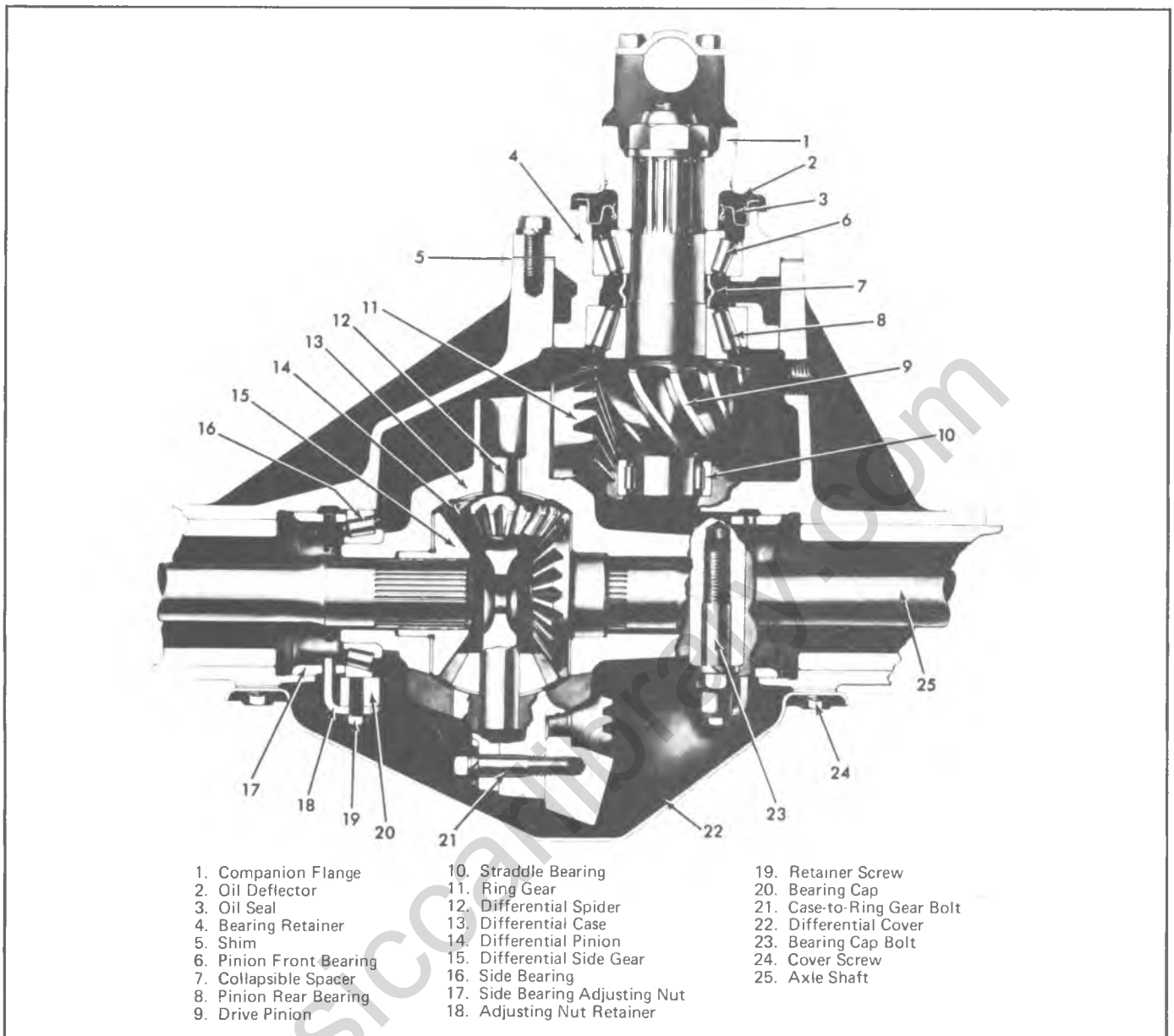

Fig. 35—10-1/2" Ring Gear Axle Cross-Section

attachment points for suspension components such as shock absorbers and leaf springs. A welded flange is provided for brake flange plate attachment.

An overhung hypoid drive pinion is supported by two preloaded tapered roller bearings. The pinion shaft is sealed by means of a molded, spring loaded, rubber seal. The seal is mounted on the pinion flange which is splined and bolted to the hypoid pinion shaft.

The hypoid ring gear is bolted to a one-piece differential case which is supported by two preloaded tapered roller bearings.

### Chevrolet 10-1/2" Ring Gear Axle

The axle shown in figure 35 is of the full floating type with hypoid ring gear and drive pinion. The full floating

construction enables easy removal of axle shafts without removing truck load and without jacking up the axle. The differential carrier is heavily ribbed to provide rigid support for the differential assembly. Differential caps are doweled to the carrier to assure correct alignment.

The straddle-mounted drive pinion is supported at the front by two opposed tapered roller bearings. The pinion straddle bearing is a roller bearing assembly consisting of an outer race and roller assembly. A precision ground diameter on the pinion pilot functions as an inner race.

Side bearing preload and ring gear-to-pinion backlash are controlled by side bearing adjusting rings threaded into the carrier near the axle tubes. Pinion depth is controlled by a shim located between the pinion bearing retainer assembly and the axle housing.

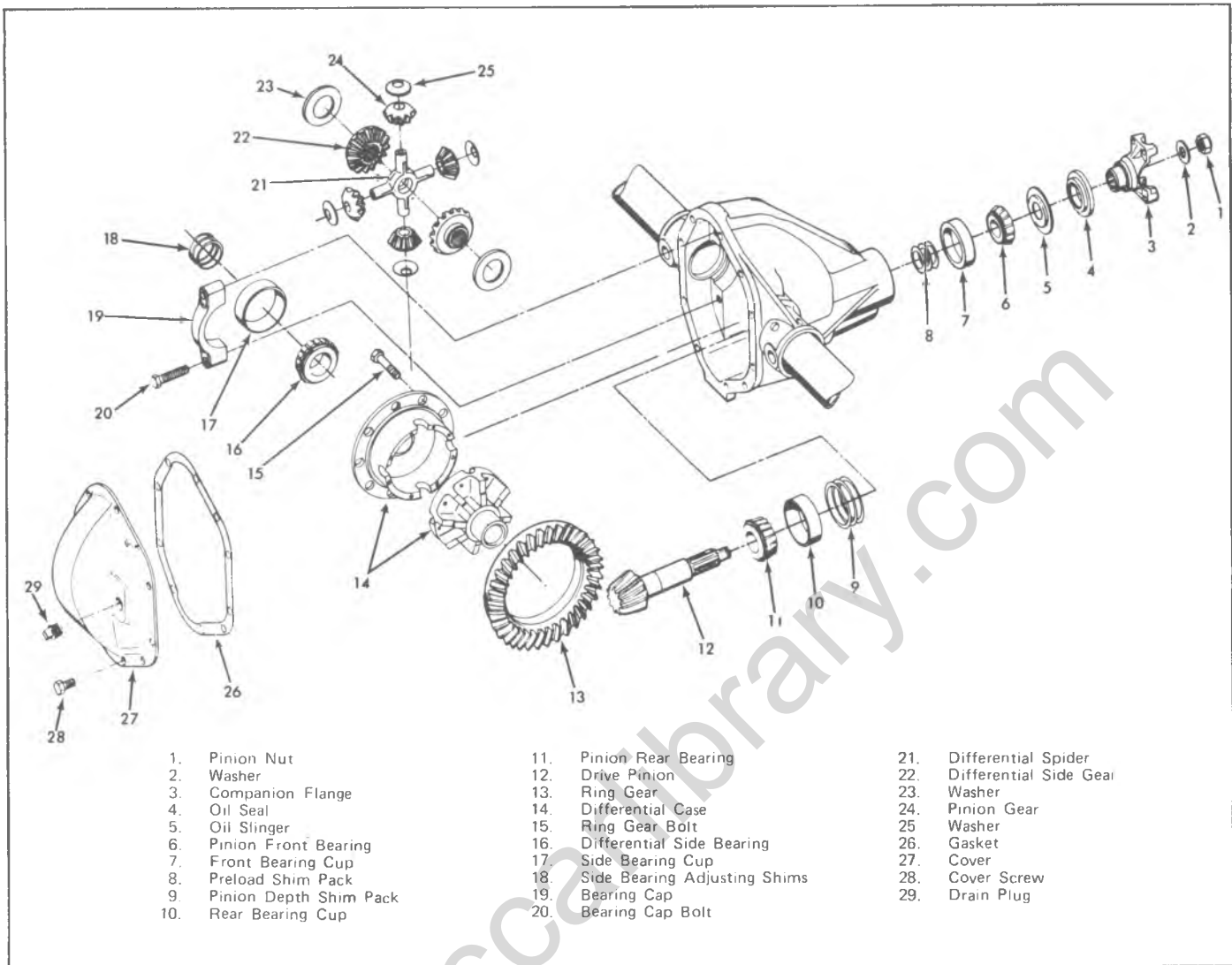

Fig. 36A—Dana 10-1/2" Ring Gear Axle Exploded View

### Dana 10-1/2" Ring Gear Axle

The Dana axle shown in figure 36A is a Salisbury-type similar in design to the 8-7/8" ring gear axle in figure 34. It does differ in several points, however. The axle shafts are full floating; the carrier must be spread to

remove the differential; and the drive pinion incorporates two shim packs. The inner pack controls pinion depth, while the outer pack controls pinion bearing preload.

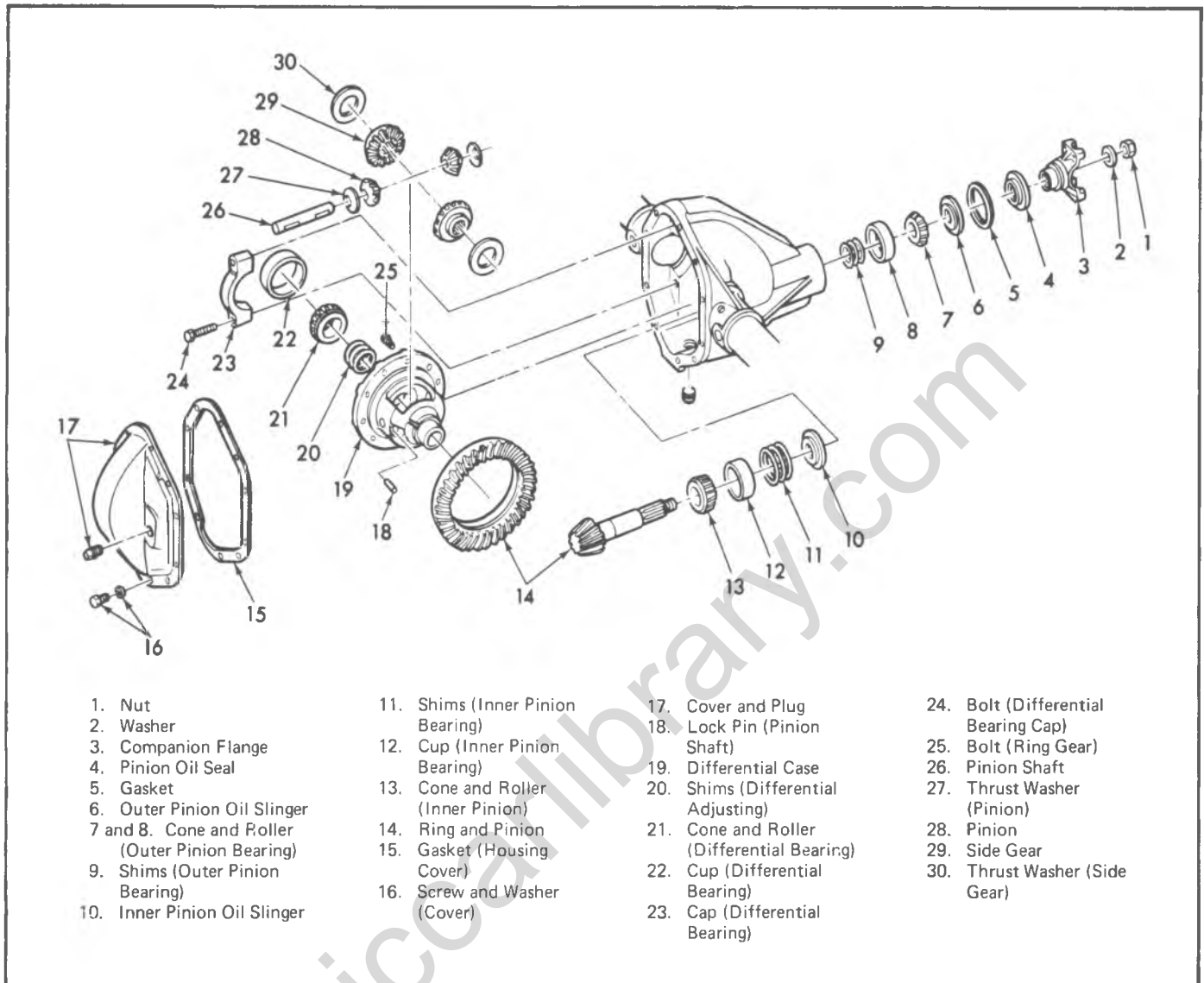

Fig. 36B—Dana 9-3/4" Ring Gear Axle Exploded View

### Dana 9-3/4" Ring Gear Axle

The Dana axle shown in figure 36B is similar to the unit shown in 36A; however, the differential side bearing shims are located between the case and the side bearings.

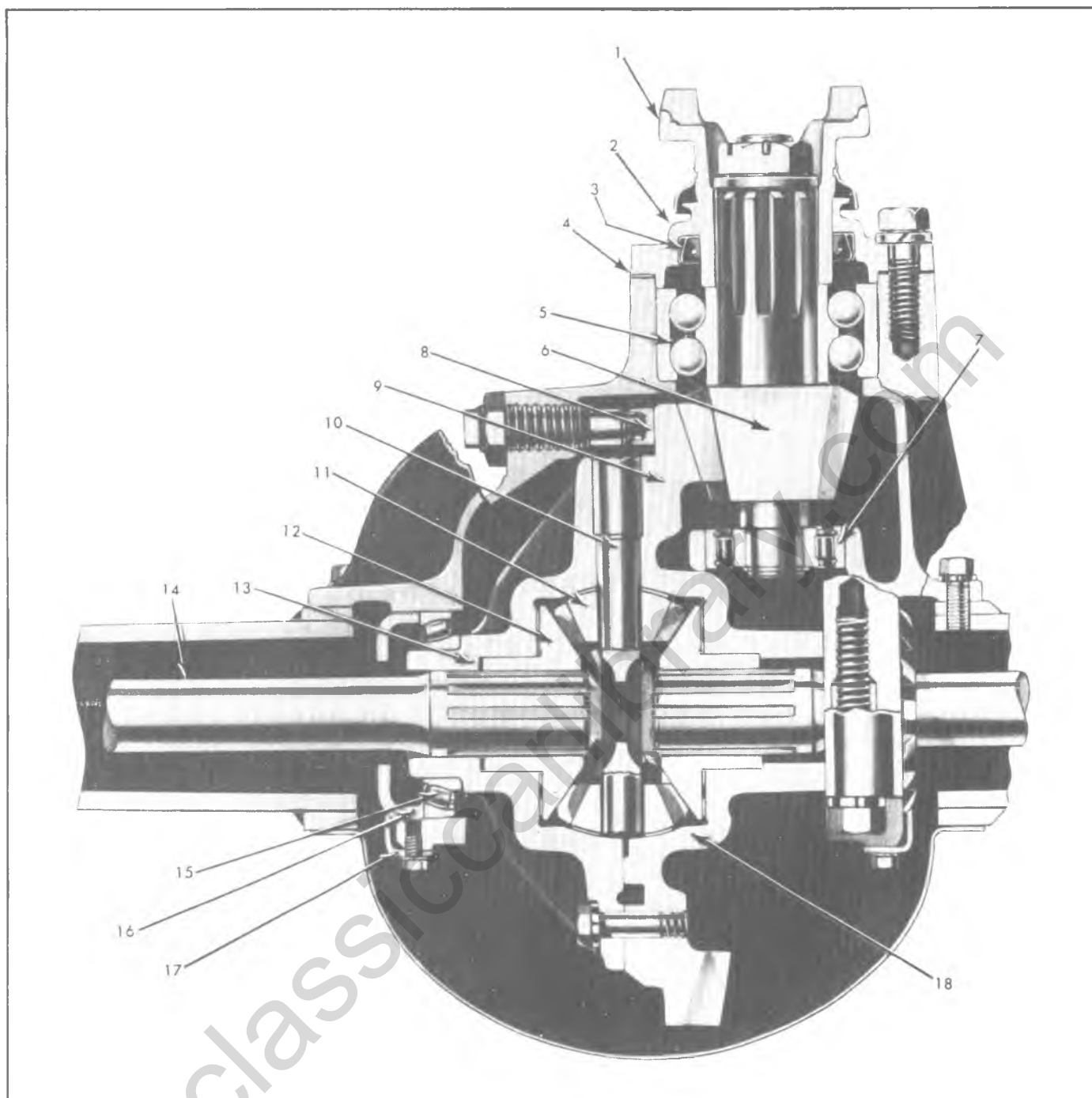

Fig. 37— 12-1/4" Ring Gear Axle—11,000# Capacity

### 12-1/4" Ring Gear Axle (11,000 Pound Capacity)

The 11,000 lb. capacity, single-speed hypoid axle, illustrated in figure 37, has a straddle mounted drive pinion which is supported at the rear by a straight roller bearing. The pinion front bearing consists of a double row ball bearing.

The differential is a conventional four-pinion type. Thrust washers are used between the side gears and case

and also between differential pinions and the differential case.

A thrust pad mounted on the end of an adjusting screw threaded into the carrier housing limits deflection of the ring gear under high torque conditions.

Involute splines are incorporated in the axle shaft flange and in the wheel hubs. This design provides for the driving torque to be transmitted from the axle shaft to the hub through the mating splines.



## THEORY OF OPERATION— STANDARD DIFFERENTIAL

The differential has two basic functions. First, it transmits torque from the propeller shaft, through a 90° turn, to the rear wheels. Second, it takes the torque provided by the propeller shaft and divides this torque as necessary to allow each wheel enough torque to rotate as conditions require.

### Gears

The rear axle transmits power through a 90° turn. To do this, bevel gears as shown in figure 38 were previously used. Straight bevel and spiral bevel gears were used for the ring and pinion gears; but the drive and driven gear center line must intersect, or meet, each other. This is satisfactory for differential side gears, but, the desire to lower the driveshaft brought about another variation of the bevel gear—the hypoid gear, shown in figure 39. Meshing hypoid gears do not require a meeting of their center lines. The drive pinion gear may then be placed below the centerline of the ring gear, thereby lowering the drive shaft.

### Gear Ratio

The drive axle of a vehicle is said to have a certain axle ratio. Most people are aware of this term, and are familiar with the ratios most frequently used on specific vehicles.

At this time, let's look into the what, how, and why of axle ratios. What is a ratio? How is it achieved? Why is it needed?

The term axle ratio is, to be more exact, the ring gear and pinion ratio. This means it is a comparison of the number of teeth of the driving and driven gears. It was found that the relative sizes of the driving and driven

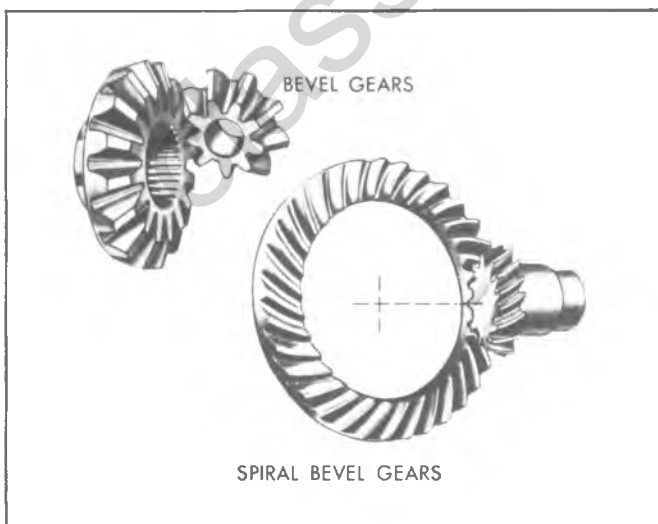

Fig. 38—Typical Bevel Gears

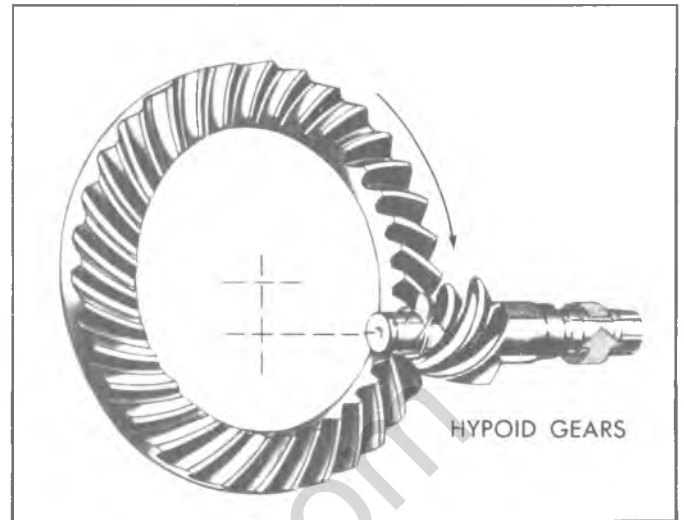

Fig. 39—Typical Hypoid Gears

gears affect the output speed and torque. As a simple example, a ring gear with twice as many teeth as the drive pinion, would turn at one half of pinion speed. This also means that since the speed is cut in half, the output torque is doubled. By applying basic laws of gearing, each axle can be designed with the most desirable axle ratio for specific applications.

The ratio numbers of an axle express the simplest comparison of the number of ring gear teeth to each drive pinion tooth. For example, the 4.11 to 1 ratio means that for each pinion tooth there are 4.11 ring gear teeth or, by the same token, the pinion turns 4.11 revolutions to each revolution of the ring gear.

When the actual component parts are seen, it is obvious that there are more than 4.11 teeth on the ring gear and 1 tooth on the pinion. The 3.11:1 gear set has 37 teeth on the ring gear and 9 on the drive pinion, or  $37 \div 9 = 4.11$ . These same divisions show that a gearset with  $43 \div 14 = 3.07$ ,  $41 \div 11 = 3.73$ , and  $39 \div 10 = 3.90$ . Therefore, the axle ratio not only gives the gear speed reduction and torque multiplication, but also states the simple ratio of the number of ring gear teeth to each drive pinion tooth.

The question of why this choice of ratios are available has several answers. First, each engine has a definite speed range in which it operates most efficiently, and supplies maximum usable torque. To take advantage of this built-in feature, a multiple speed transmission is employed. This permits the operator to maintain proper engine speed regardless of road speed. But, to make the transmission as simple and practical as possible, high gear is normally direct drive. This means that the engine and drive shaft turn at the same relatively high rate of speed with no torque multiplication. Since each vehicle's job application, engine, wheel size, and terrain condition requires a specific speed and torque rate at the axle shaft, the gear ratio of the axle allows the tailoring of the power train to the job.

## 4-22 REAR SUSPENSION AND DRIVELINE

### Differential Operation

A differential is an arrangement of gears that divides the torque between the axle shafts and allows them to rotate at different speeds. A basic differential consists of a set of four gears. Two of these gears are called differential side gears, and the other two are differential pinion gears. Some differentials have more than two pinion gears. Each side gear is splined to an axle shaft. Consequently, each axle shaft must turn when its side gear rotates.

The differential pinion gears are mounted on a differential pinion shaft, and the gears are free to rotate on this shaft. The pinion shaft is fitted into a bore in the differential case and is at right angles to the axle shafts.

Power flow through the differential is as follows: The drive pinion rotates the ring gear. The ring gear, being bolted to the differential case, rotates the case. The differential pinion, as it rotates with the case, forces the pinion gears against the side gears. When both wheels have equal traction, the pinion gears do not rotate on the pinion shaft because the input force on the pinion gear is equally divided between the two side gears. See figure 40. Consequently, the pinion gears revolve with the pinion shaft, but do not rotate around the shaft itself.

The side gears, being splined to the axle shafts and in mesh with the pinion gears, rotate the axle shafts.

If a vehicle were always driven in a straight line, the ring and pinion gears would be sufficient. The axle shaft could then be solidly attached to the ring gear and both driving wheels would turn at equal speeds.

However, if it became necessary to turn a corner, the tires would scuff and slide because the outer wheel would travel further than the inner wheel, as in figure 41. To prevent tire scuffing and sliding, the differential becomes effective and allows the axle shafts to rotate at different speeds.

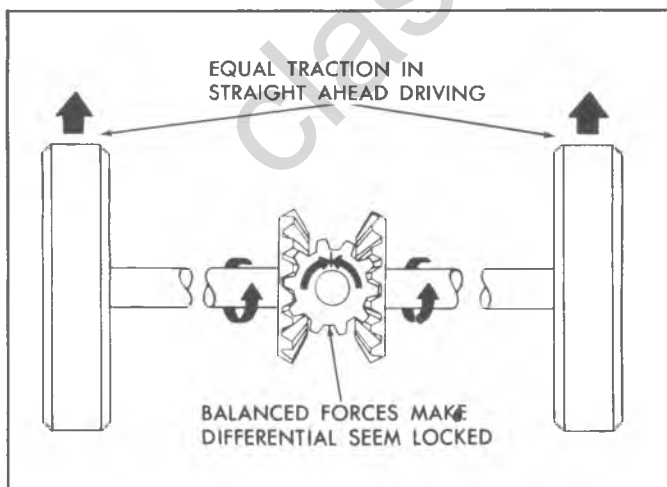

Fig. 40—Differential Inactive

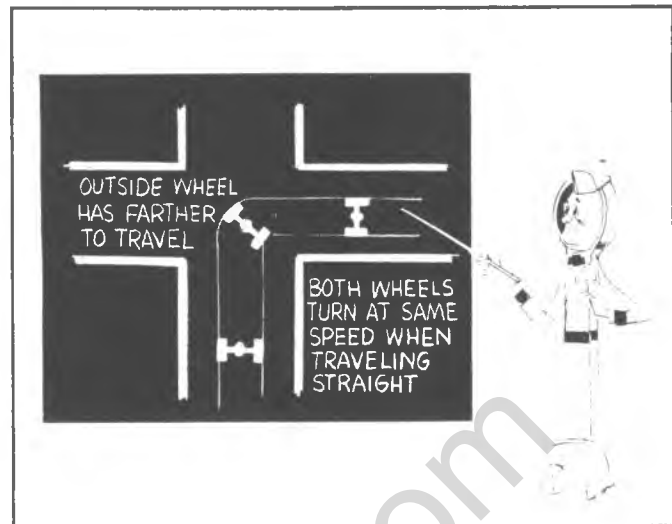

Fig. 41—Need for Differential Action

As the inner wheel slows down, the side gear splined to that axle shaft also slows down. At this point, the pinion gears act as balancing levers by maintaining equal speeds of rotation of the axle shafts. See figure 42. If the vehicle speed remains constant and the inner wheel slows to 90% of vehicle speed, the outer wheel speeds up to 110%. If the inner wheel slows to 75%, the outer wheel would turn 125%. If one wheel stopped, the other wheel would turn 200%.

### BEARINGS

#### General Information

Roller bearings are precision products. Component parts are carefully machined, heat treated and ground to exacting tolerances and high surface finishes to provide a maximum service life.

When properly installed, they demonstrate unusual resistance to wear, heavy loads and difficult usage. Despite their ruggedness, they are susceptible to

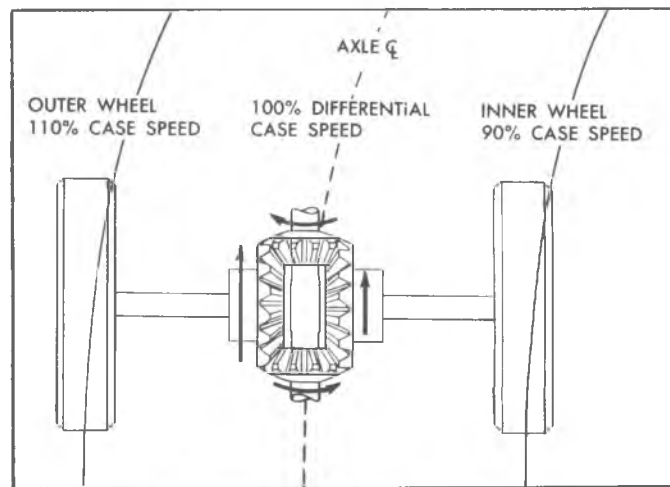

Fig. 42—Differential Action on Turns

mishandling in storage and installation. They are adversely affected by dirt and they should be protected from rust and corrosion.

Bearings are carefully assembled, washed, dried and either lubricated or treated with a rust preventative at the factory. They are then packaged for protection and shipped to a distributor or to the ultimate user.

Bearings should not be removed from the original packaging until they are ready for installation. When a bearing is shipped from the factory it is ready for installation. No cleaning or washing is recommended. Field washing of new bearings, prior to installation, seldom improves on the factory cleaning and could impair the original cleanliness of the bearing.

Once a bearing has been removed from the original packing, care must be exercised to prevent damage from dirt and corrosion. Many bearing failures are the result of improper handling, careless installation, misuse or abuse rather than actual wear or fatigue in service.

The useful life expectancy of bearings can be greatly extended if proper installation and maintenance practices are observed.

### Removal Procedures

Regardless of the means used to remove bearings or races, it is absolutely essential that the driving force be directed through the **press fitted race**. For example, if a non-separable bearing is to be removed from a shaft, the force must travel through the inner race and never through the outer race, rollers or separator.

In most applications, it will be found that the roller bearing has been assembled with a tight press fit holding the rotating race, and with a relatively free fit holding the stationary race. Removing the race with the free fit can be done quite easily, but the race with the tight press fit will require considerable force, which must be applied in such a way that the bearings and component parts are not damaged.

**The Arbor Press.** The arbor press is one means of applying the force necessary to remove bearings or races from shafts and housings. Its action is rapid, smooth and positive, making it an especially useful tool where a great deal of bearing removal work is done. In addition, the arbor press can supply a greater force than is available from most other bearing removal appliances, making it possible to remove some bearings which might not even be budged by bearing pullers or by hammering.

With the arbor press, the bearing is supported on the press base plate with some simple accessories. These may consist of flat bars placed beneath the inner race adjacent to the shaft. A piece of flat stock with a U-shaped cutout is preferable when this operation has to be repeated often. A third type of accessory is the split ring, a circular ring bored slightly larger than the shaft diameter and sawed into two semi-circular segments.

The arbor press can only be used to remove races or bearings from housings which are so designed that some

portion of the outer race can be exposed. In cases where the entire face of the outer race is exposed, a section of pipe or tubing, capped by a steel block, can be used. In other cases, the shoulders against which the outer races rest are slotted to allow a flat bar to contact the outer race in two diagonally opposite places. The important thing to remember in any of these operations is that the force should only be directed through the **press-fitted race**, and that the press base plate and accessories are clean, and that all contacting surfaces are flat and true.

**Bearing Pullers.** Bearing pullers are a useful and convenient means of removing bearings and races, where no arbor press is available, or where the shaft is too large or is obstructed and cannot go into a press.

The bearing puller must be applied so that the pressure is directed through the press-fitted race, and that no force is carried through the rollers or snap rings. The puller can be used without accessories to draw off inner races where no obstructions interfere and where long reach is not necessary. In most cases, the split collar puller plate is placed in back of the bearing to carry the load directly to the inner race. In some applications, a gear, pulley or cover plate can be used instead of the split collar. When bearing pullers having adjustable legs are used, it is important that the legs be of equal length and symmetrically placed.

### Cleaning of Used Bearings

Bearings which have been removed from service should be cleaned before storing, even when the storage is to be only of short duration. The bearing should be cleaned thoroughly, removing all oil and hardened grease accumulations, as well as any sludge which may be deposited on the outer surfaces of the races. Remember that cleaning of bearings is important and, whenever possible, should be done before relubricating bearings.

Bearings can be cleaned easier and more thoroughly when they have been removed from their housings and shafts. When this is not possible, a light oil heated at

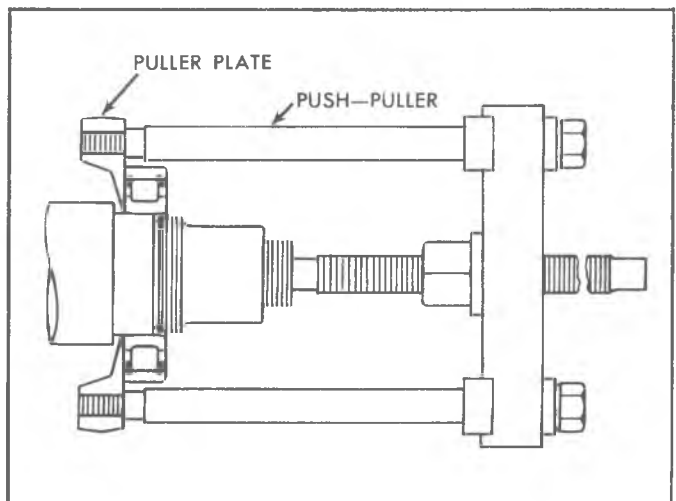

Fig. 43—Typical Inner Race Removal

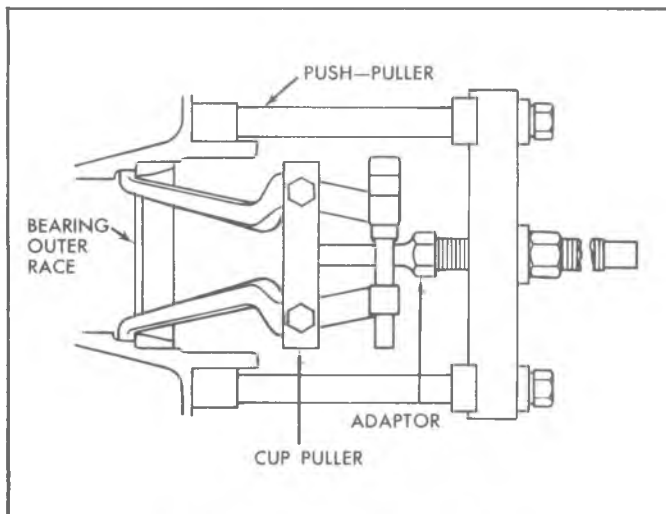

Fig. 44—Typical Outer Race Removal

180° to 200°F should be flushed through the housing while slowly rotating the bearing. Where the grease or oil is badly oxidized and cannot be removed by this method, a petroleum solvent such as kerosene or safety-naphtha may prove effective. In extreme cases, a mixture of alcohol and kerosene or safety-naphtha will remove the greater part of the sludge and scale. When petroleum solvents, by themselves or with alcohol added, are used in this manner, they should be followed by a flushing with light oil before the lubricant is added to the housing. This will wash away any of these solvents which would otherwise dilute the lubricant.

Where it is possible to dismount the bearings, they should be placed in a metal basket and suspended in a container of some clean, cold petroleum product. There they should soak, if possible, overnight. If no metal basket is available, the bearings may be suspended in the solution by a length of wire. Do not let the bearings rest on the bottom of the container. If the lubricant is badly oxidized, the bearings should be soaked in a light oil heated at 180° to 200°F, and the basket or wire sloshed through the oil slowly as often as possible. In cases of extreme sludging, the bearings may be soaked in a mixture of alcohol and kerosene or safety-naphtha.

In cleaning bearings, use plenty of clean rags for wiping and handling. Do not use cotton waste as the short threads may get into the bearings.

A brush may be useful in helping the oil or solvent to remove dirt, scale or chips from bearings. Care should be taken that none of the bristles become lodged between the rollers and races, because a piece of bristle can be as harmful as a steel chip.

Compressed air which is entirely free from condensed moisture may be used to blow out bearings, but only after all dirt and chips have been removed by sloshing or brushing. **Do not spin the bearings with compressed air as dirt or chips present may cause indenting of the raceways.**

### Installation Procedures

Before pressing a bearing back on the shaft, the bearing seat should be thoroughly cleaned of all dirt, carbonized lubricant or any other foreign matter present. Not only may such things cause scoring of the shaft and the bearing bore, but an improper bearing installation may result. Dirt on the shaft may move ahead as the bearing is pressed on the shaft, and pack between the inner race and shaft shoulder. This in itself results in an improper adjustment. If the dirt is later washed loose, the end thrust on the bearing may cause a sideways movement of the shaft which might cause misalignment of other component parts.

After the bearing seat and the bearing bore have been cleaned, they should be coated with lubricant. This not only aids in pressing on the bearing but helps to prevent the formation of rust at the press fit, and also assists any later removal of the bearing.

The pressure required to drive bearings onto shafts or into housings must be applied through the races. Where bearings or bearing parts are assembled on shafts, apply the pressure to the face of the inner race. Where bearings or bearing parts are assembled in housings, apply pressure to the face of the outer race. If the pressure is directed through the wrong race or against the rollers, cage or snap rings, brinelling, bending or fracture may result.

The pressure, as well as going through the proper race, should be directed straight and square. This means that the pressure should be distributed as uniformly as possible over the entire face of the race. Concentrating the load on one side of the race will cause cocking and may result in scoring the shaft or splitting the race. The pressure should be directed straight down as a force applied at an angle may result in damage to the shaft or to the bearing separator or grease seal.

**The Arbor Press.** The arbor press provides one of the best means of mounting bearings and races, for its

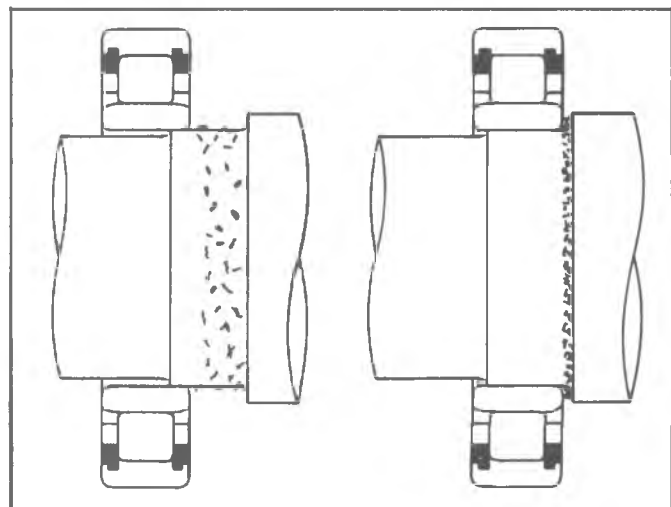

Fig. 45—Effect of Dirt on Bearing Seat

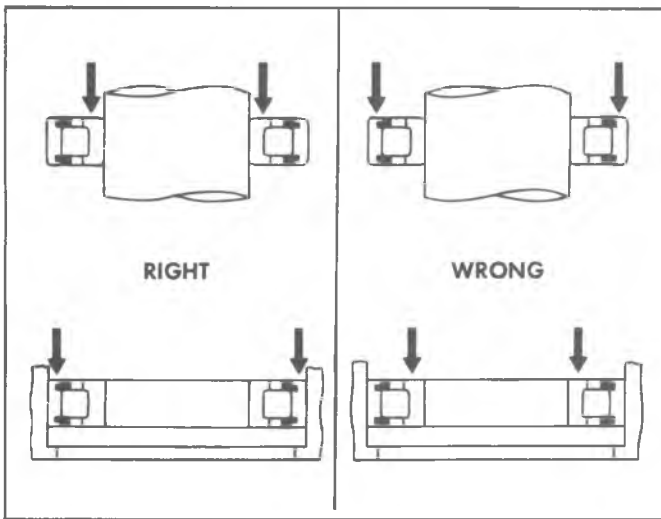

Fig. 46—Applying Pressure on the Correct Race

action is rapid and pressure can be applied continuously. Special precaution should be taken when using the arbor press to align the race squarely on the shaft, as the great pressures which can be exerted by the press could easily cause race cracking or severe scoring of the shaft, if the race were started unevenly. Accessory equipment such as drive plates, tubing or pipes which will carry the force through the press fitted race, should be used whenever necessary.

**Drive Blocks.** Drive blocks furnish one of the most convenient means of driving a bearing onto a shaft or into a housing. They are simple to construct and are especially useful where the operation is repeated time after time. Drive blocks can be used for either outer race, inner race or complete bearing assembly. They must be so constructed, however, that the pressure travels only through the press-fitted race, and that the race is brought up snug against the shoulder or other means of retention provided for it.

**Pipe or Tubing.** Pipes or tubes can be used to assemble

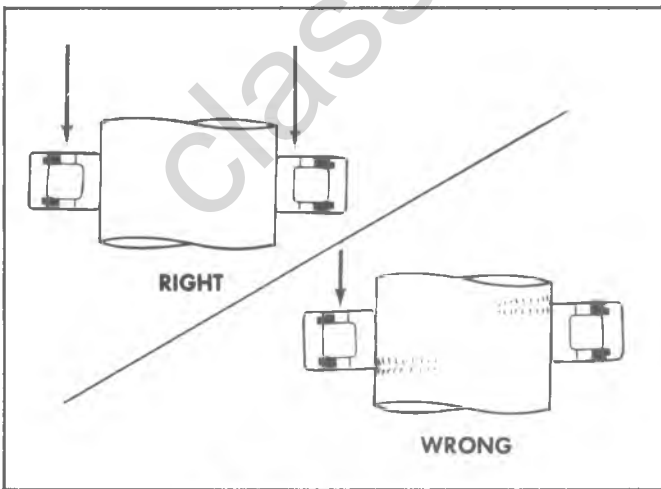

Fig. 47—Apply Pressure Evenly

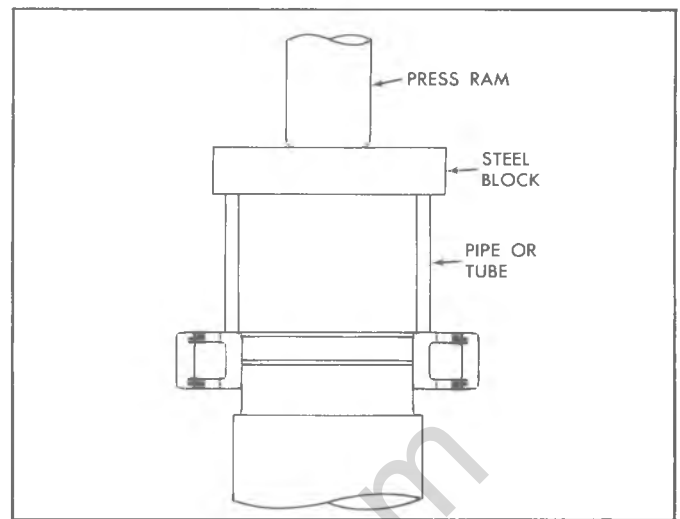

Fig. 48—Bearing Installation Using Arbor Press

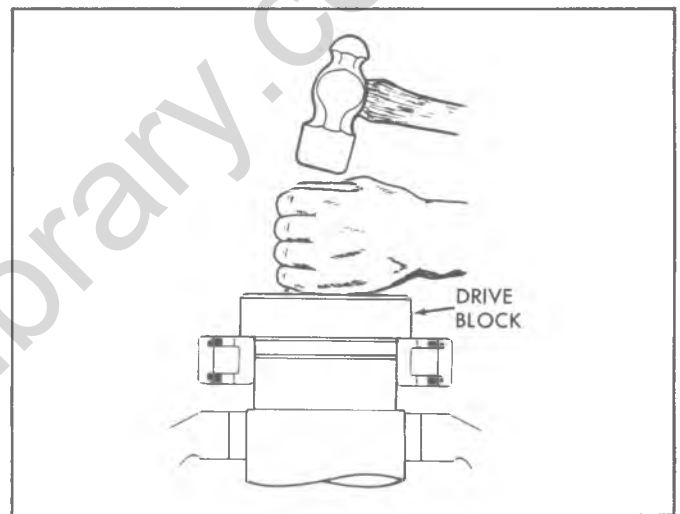

Fig. 49—Bearing Installation Using Drive Block

races or bearings in the same manner that they are used to remove them. The same process can be used to drive the outer race into the housing. Besides, pipe or tubing can be used in conjunction with an arbor press as well as with a hammer. The pressure should be distributed over the end of the tube by means of a steel block or cap.

**Points to Remember**

1. Make sure that shaft seat and housing bore are clean, smooth and of the correct diameter.
2. Do not remove bearings from package until ready for assembling.
3. Lubricate the surfaces of the bearings and machine part which are to be press fitted.
4. Start bearings on shaft with rounded corner radius of race going first.
5. Direct the driving pressure directly through race to be press fitted, making sure that pressure is directed straight and square.

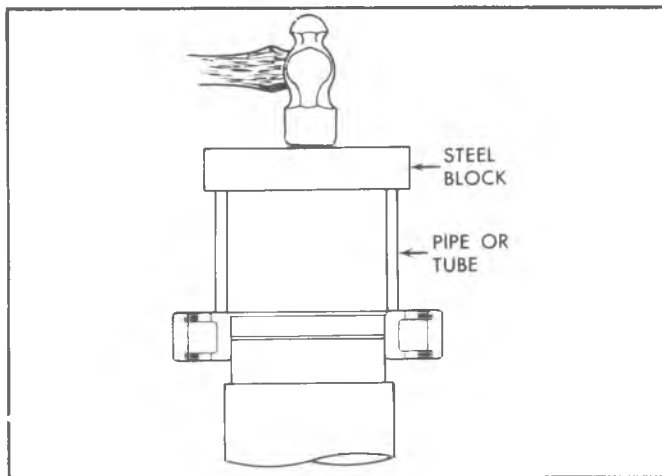

Fig. 50—Bearing Installation Using Pipe or Tube

6. Never hammer directly on races or rollers, and never use a wooden or soft metal mallet, as chips or splinters may enter the bearing.
7. Use many smart quick taps rather than a few heavy ones.
8. Have straight square ends on driving accessories and fixtures.
9. Drive races solidly up against shoulder of shaft and housing.
10. **Clean tools, clean hands and clean surroundings are essential if damage to the bearing is to be avoided.**

## COMPONENT PARTS REPLACEMENT

### 8-7/8 RING GEAR AXLE

#### AXLE ASSEMBLY

Construction of the axle assembly is such that service operations may be performed with the housing installed in the vehicle or with the housing installed in a holding fixture. The following removal and installation procedure is necessary only when the housing requires replacement.

**CAUTION:** See *CAUTION* on page 1 of this section, regarding Axle Assembly fasteners.

#### Removal

1. Raise vehicle on hoist.
2. Support rear axle assembly with suitable lifting device, so that tension is relieved in springs and shock absorbers.
3. Remove trunnion bearing "U" bolts from the axle companion flange, separate trunnion from flange, position propeller shaft to one side and tie it to frame side rail.

**NOTE:** Secure trunnion bearing caps to trunnion, using masking tape or a large rubber band, to prevent loss of bearings.

4. Disconnect shock absorbers at lower attachment points and position out of the way.
5. Disconnect axle vent hose from vent connector and position vent hose to one side.
6. Disconnect hydraulic brake hose at connector on axle housing. Remove brake drum, disconnect parking brake cable at actuating levers and at flange plate. Refer to Section 5 for cable removal and brake details. Remove axle "U" bolt nuts, "U" bolts, spacers and clamp plates.
7. Lower axle assembly and remove from vehicle.

#### Installation

1. Position axle assembly under vehicle and align with springs.
2. Install spacer, clamp plate and "U" bolts to axle assembly, loosely install retaining nuts to "U" bolts.
3. Position shock absorbers in lower attachment brackets and loosely install nut to retain shock.
4. Connect axle vent hose to vent connector at carrier.
5. Connect hydraulic brake hose to connector on axle housing, connect parking brake cable to actuating levers. Install brake drum and wheel and tire assembly—bleed brakes and adjust parking brake as outlined in applicable portion of Section 5.
6. Reassemble the propeller shaft to companion flange, making sure that bearing caps are indexed in flange seat. Torque bearing cap retaining nuts to specifications.
7. Position vehicle so that weight is placed on suspension components and torque affected parts to specifications.
8. Lower vehicle and remove from hoist.

#### AXLE SHAFT

##### Removal

1. Raise vehicle on hoist. Remove wheel and tire assembly and brake drums.
2. Clean all dirt from area of carrier cover.
3. Drain lubricant from carrier by removing cover.
4. Remove the differential pinion shaft lock screw and the differential pinion shaft as shown in figure 51.
5. Push flanged end of axle shaft toward center of vehicle and remove "C" lock from button end of shaft.
6. Remove axle shaft from housing, being careful not to damage oil seal.

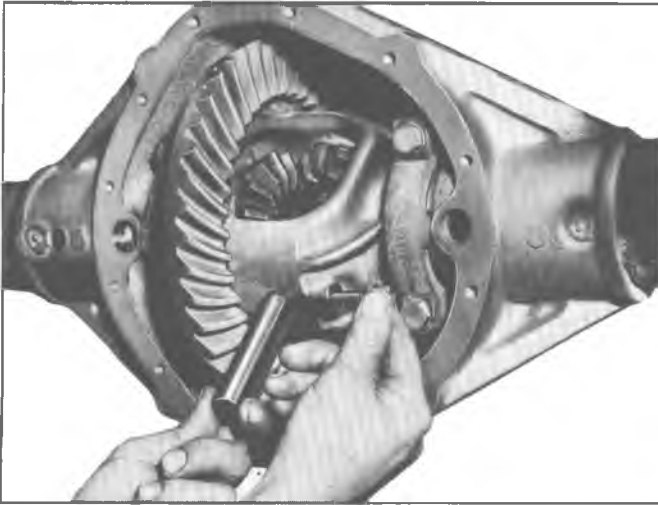

Fig. 51—Differential Pinion Shaft Removal

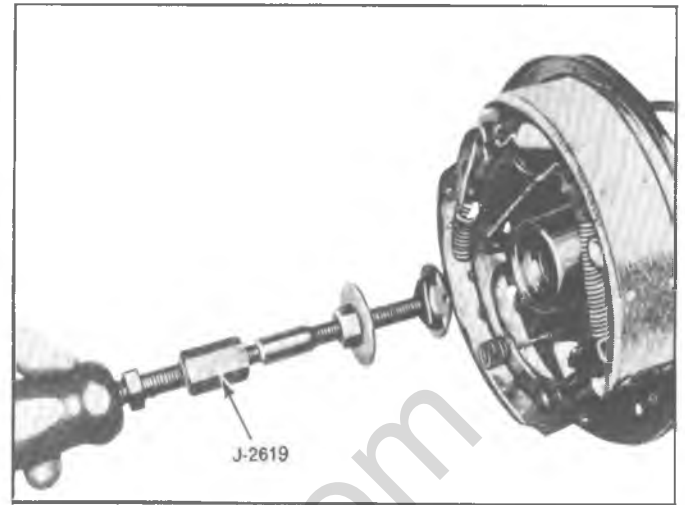

Fig. 53—Wheel Bearing Removal

### Oil Seal/Bearing—Replacement

1. Remove oil seal by using button end of axle shaft. Insert button end behind the steel case of the oil seal, then pry seal out of bore being careful not to damage seal. If both seal and bearing are being replaced proceed to step 2.
2. Using J-23689, insert into bore so that tool grasps behind the bearing. See figure 53. Slide washer against outside of seal (or bearing) and turn nut finger tight against washer. Attach Slide Hammer J-2619 and remove bearing and seal.
3. Back off nut and remove bearing and seal from tool.
4. Lubricate cavity between seal lips with wheel bearing lubricant and also lubricate new bearing with wheel bearing lubricant.
5. To reinstall bearing, use J-23690 Installer. Install bearing until tool bottoms against tube as illustrated in figure 54.

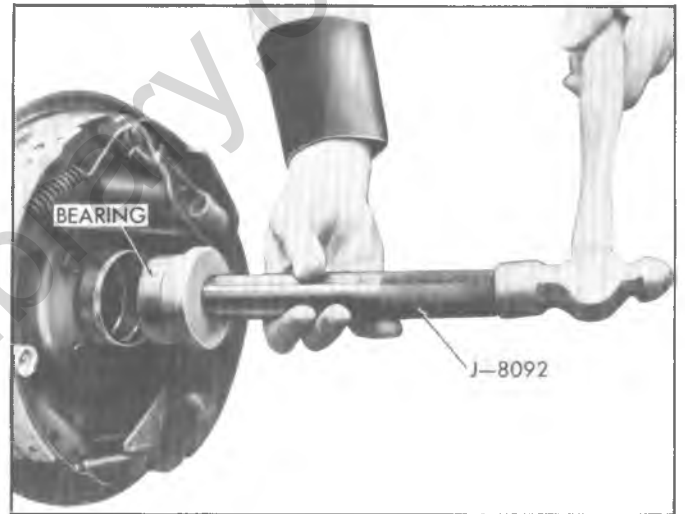

Fig. 54—Wheel Bearing Installation

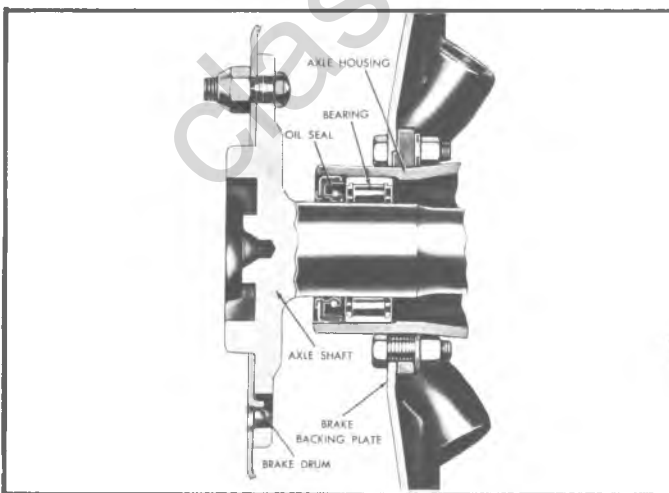

Fig. 52—Oil Seal and Wheel Bearing

6. To install oil seal, place seal on J-21128 and drive into bore until tool bottoms against end of tube. See figure 55. This tool installs the seal flush with the end of the tube.

### Brake Backing Plate—Replacement

1. Remove brake line at wheel cylinder inlet and disassemble brake components from flange plate. Refer to Section 5 for brake disassembly procedure.
2. Remove bolts retaining flange plate to axle, and remove flange plate.
3. Install new flange plate to axle housing and torque nuts to specifications.
4. Install brake components on flange and connect hydraulic line to wheel cylinder inlet. See Section 5 for brake assembly, bleeding and adjustment procedures.

## 4-28 REAR SUSPENSION AND DRIVELINE

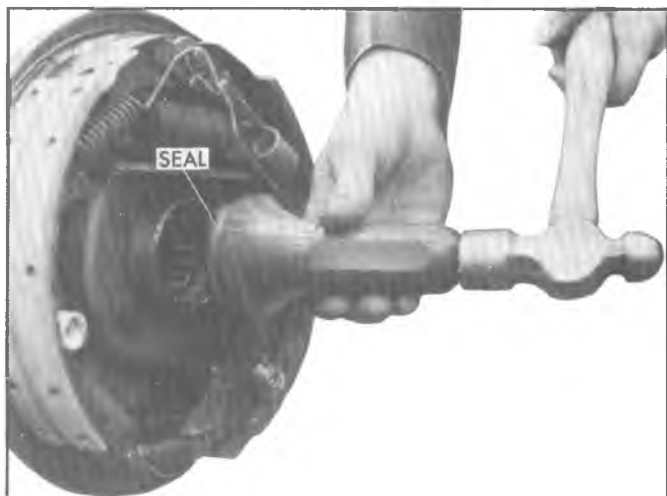

Fig. 55—Seal Installation

### Axle Shaft—Installation

1. Slide axle shaft into place.

**CAUTION:** Exercise care that splines on end of shaft do not damage oil seal and that they engage with splines of differential side gear.

2. Install axle shaft "C" lock on button end of axle shaft and push shaft outward so that shaft lock seats in counterbore of differential side gear.
3. Position differential pinion shaft through case and pinions, aligning hole in shaft with lock screw hole. Install lock screw and torque to specifications.
4. Using a new gasket, install carrier cover and torque bolts to specifications.

**CAUTION:** Make sure both gasket surfaces on carrier and cover are clean before installing new gasket. Torque carrier cover bolts in a crosswise pattern to ensure uniform draw on cover gasket.

5. Fill axle with lubricant as specified in Section 0 of this manual to a level even with the bottom of filler hole.
6. Install brake drum and wheel and tire assembly.
7. Lower vehicle and remove from hoist.

### Wheel Bolt—Replacement

1. Raise vehicle on hoist allowing axle to hang freely.
2. Remove wheel and tire and brake drum.
3. Using Tool J-5504 or J-6627 press out stud as shown in figure 56.
4. Place new stud in axle flange hole. Slightly start stud serrations in hole by firmly pressing back of stud with your hand.
5. Install a lug nut with flat side first (tapered face outboard). Tighten on lug nut drawing stud into flange until stud head is bottomed on back side of flange.

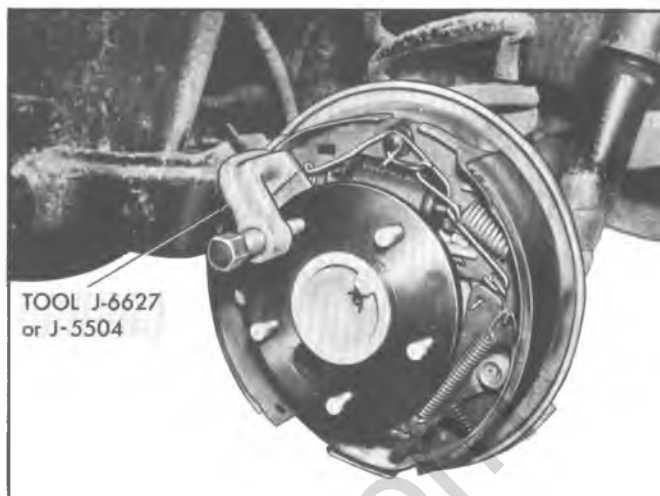

Fig. 56—Pressing Out Wheel Stud

6. Remove lug nut.
7. Reinstall brake drum and wheel and tire.
8. Lower vehicle and remove from hoist.

### PINION FLANGE, DUST DEFLECTOR AND/OR OIL SEAL

#### Removal

1. Raise vehicle on hoist.
2. Disconnect propeller shaft from axle.
3. Position propeller shaft to one side and tie it to frame side rail.
4. Measure the torque required to rotate the pinion, as shown in figure 57. Record the torque for later reference.
5. Scribe a line down pinion stem, pinion nut, and flange to aid on reinstallation. Make sure lines show the relationship of components accurately. Count

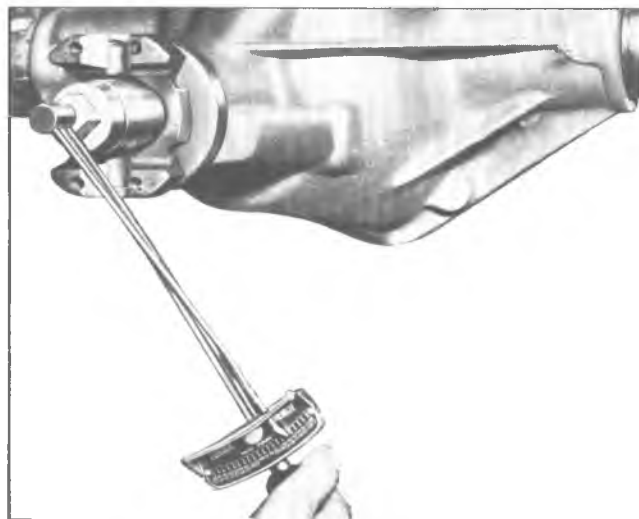

Fig. 57—Measuring Pinion Rotating Torque



the number of exposed threads on pinion stem, and record for later reference. See figure 58.

6. Install Tool J-8614-11 on pinion flange and remove pinion flange self-locking washer faced nut as shown in figure 59. (Position J-8614-11 on flange so that the four notches are toward flange.) Save scribed nut for reinstallation.
7. Thread pilot end of Tool J-8614-3 into small O.D. end of J-8614-2. Then with J-8614-11 installed as in Step 6, insert J-8614-2 into J-8614-11 and turn it 45 degrees to locked position. Remove flange by turning J-8614-3 while holding J-8614-11 as shown in figure 60.
8. Pry old seal out of bore, using a screw driver or a hammer and chisel.

**Inspection**

1. Inspect pinion flange for smooth oil seal surface, worn drive splines, damaged ears, and for

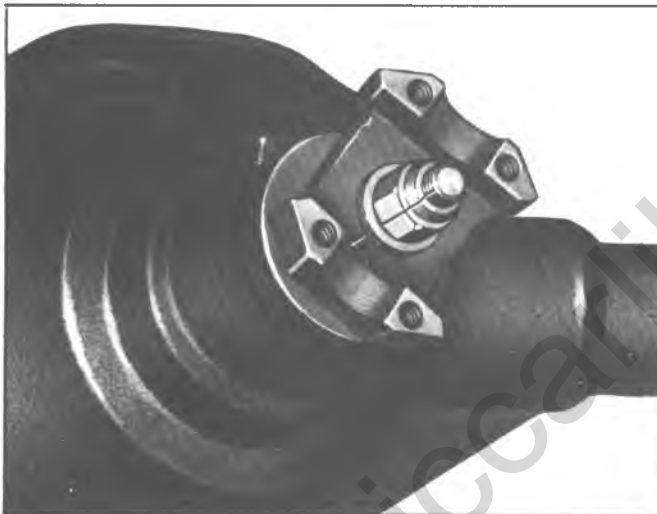

Fig. 58—Scribe Marks

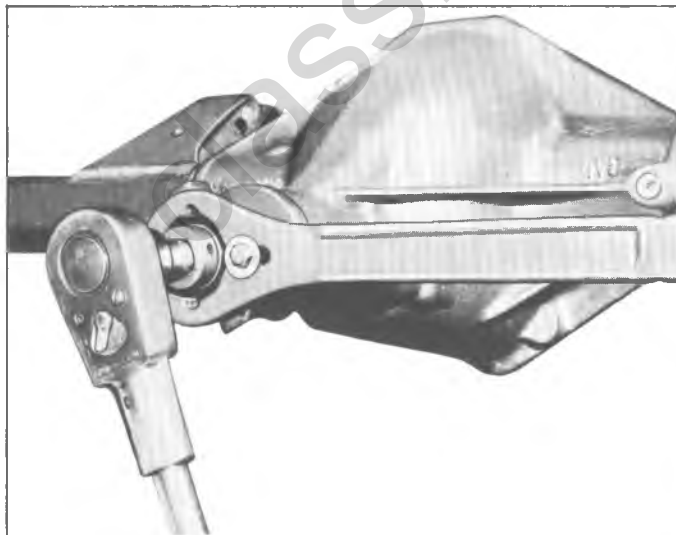

Fig. 59—Removing Nut from Drive Pinion

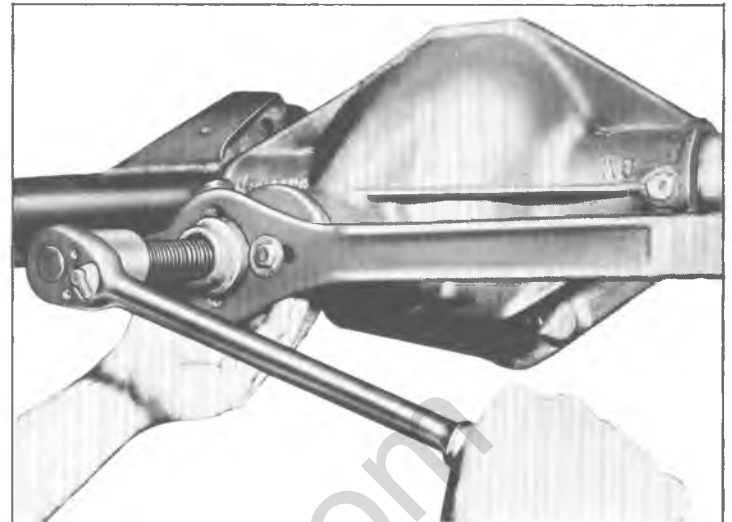

Fig. 60—Drive Pinion Flange Removal

smoothness of bearing contact surface. Replace if necessary.

2. If deflector requires replacement, remove by tapping from flange, clean up stake points; install new deflector, and stake deflector at three new equally spaced positions.

NOTE: Staking operation must be performed in such a manner that the seal operating surface is not damaged.

**Installation**

1. Lubricate cavity between the seal lips of the pinion flange oil seal with a lithium-base extreme pressure lubricant.
2. Position seal in bore and place gauge plate J-22804-1 over seal and against seal flange. The gauge plate assures proper seating of seal in carrier bore.
3. Use J-21057, as shown in figure 61, to press seal into carrier bore until gauge plate is flush with the carrier shoulder and seal flange. Turn gauge plate 180° from installed position; seal must be square in carrier bore to seal properly against pinion flange.
4. Lubricate the cavity between end of pinion splines and pinion flange with a non-hardening sealer (such as

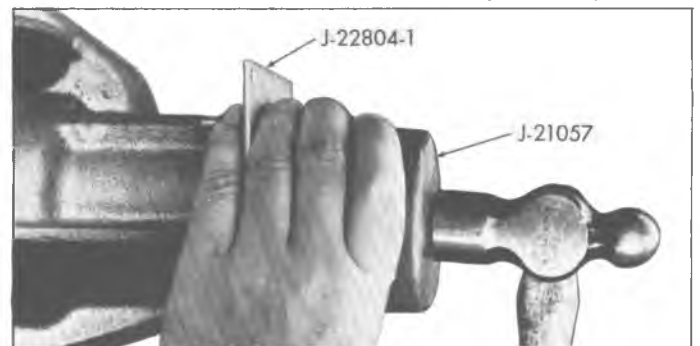

Fig. 61—Pinion Oil Seal Installation

## 4-30 REAR SUSPENSION AND DRIVELINE

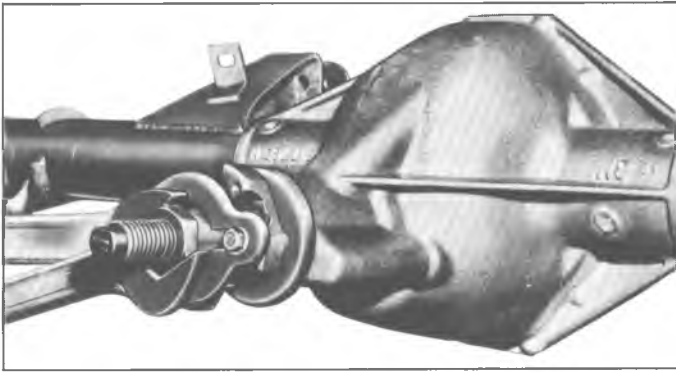

Fig. 62—Installing Pinion Flange

Permatex Type A or equivalent) prior to installing washer and nut on pinion.

5. Using J-8614-11 as shown in figure 62, install flange onto pinion. Install washer and nut, and tighten nut to original position. Refer to scribe marks and number of exposed threads, recorded earlier.

**NOTE:** Do not attempt to hammer the flange onto pinion shaft. To do so may damage the ring gear and pinion.

6. Measure rotating torque of pinion and compare with torque recorded before removal. Tighten pinion nut in additional **small** increments until the torque necessary to rotate the pinion exceeds the original figure by 1 to 5 inch pounds. **Do not** exceed the original torque by more than 5 inch pounds.
7. Reattach propeller shaft and torque to specifications. Reinstall brake drums and wheels.

**CAUTION:** See *CAUTION* on page 1 of this section regarding the fasteners referred to in step 7.

8. Lower vehicle and remove from hoist.

### CHEVROLET 10-1/2 RING GEAR AXLES

#### AXLE ASSEMBLY

Service operations on these axle assemblies may be performed with the housing installed in the vehicle or with the housing installed in a holding fixture. There may be occasions, however, when it will be necessary to remove the complete housing assembly. The following axle assembly removal and installation procedure, therefore, is necessary only when housing replacement is required.

**CAUTION:** All axle attachments are important attaching parts. See *CAUTION* on page 1 of this section.

#### Removal

1. Raise vehicle, place stand jacks under frame side rails, and remove rear wheels.

2. Remove two trunnion bearing "U" bolts from the rear yoke, split rear universal joint, position propeller shaft to one side, and tie it to the frame side rail.

**NOTE:** The bearings can be left on the trunnion and held in place with tape.

3. Remove hub and drum assembly and disconnect parking brake cable at lever and at flange plate. See Section 5 for cable removal.
4. Disconnect hydraulic brake hose at connector on rear axle housing. Refer to Section 5.
5. Disconnect shock absorbers at axle brackets.
6. Support axle assembly with hydraulic jack, remove spring "U" bolts, and lower axle assembly to the floor.

#### Installation

1. Place axle assembly under vehicle, raise into position, install spring "U" bolts, anchor plates and nuts, and tighten securely.
2. Connect and secure shock absorbers to axle brackets.
3. Connect brake hose at connector on rear axle housing.
4. Install hub and drum assembly. Connect parking brake cable at lever and flange plate. Bleed brake hydraulic system and adjust parking brake.
5. Reassemble the rear universal joint, making sure that "U" bolts are drawn up tight and locked properly. Caution should be taken not to overtighten "U" bolt nuts and cause bearing cups to become distorted.
6. Install rear wheels, remove stand jacks, and lower vehicle.
7. Test operation of brakes and rear axle.

#### AXLE SHAFT

##### Replacement

1. Remove bolts and lock washers that attach the axle shaft flange to the wheel hub. See figure 63.
2. Rap on flange with a soft-faced hammer to loosen shaft. Grip the rib on end of flange with a pair of locking pliers and twist to start shaft removal. Remove shaft from axle tube.
3. Thoroughly clean both the axle shaft flange and the end of the wheel hub.

**NOTE:** Any lubricant on these surfaces tends to loosen axle shaft flange bolts.

4. Place a new gasket over the axle shaft and position the axle shaft in the housing so that the shaft splines enter the differential side gear. Position gasket so that holes are in alignment and install flange-to-hub attaching bolts. Torque bolts to specifications.

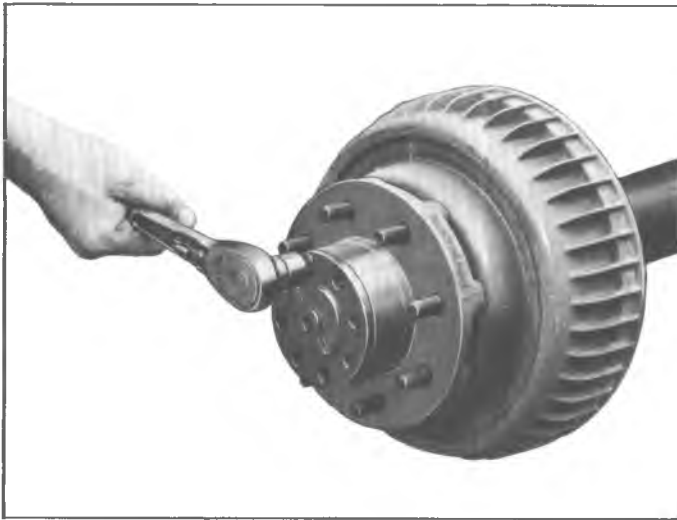

Fig. 63—Removing Flange-to-Hub Bolts

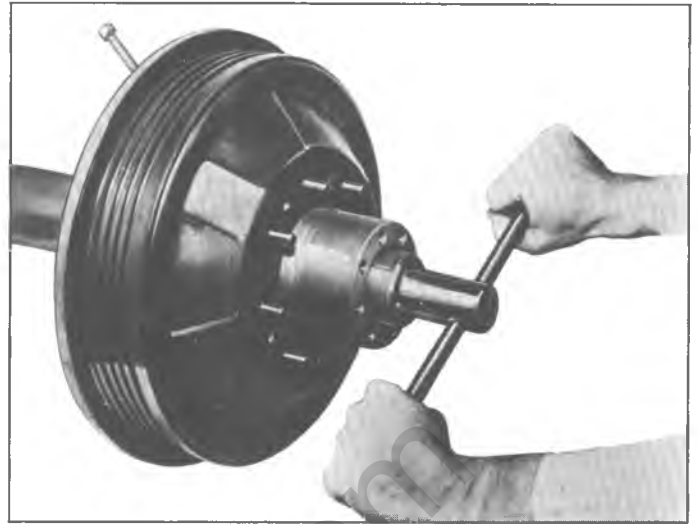

Fig. 65—Removing Lock Nut—Typical

### HUB AND DRUM ASSEMBLY—FIG. 64

#### Removal

1. Remove axle shaft as outlined earlier.
2. Disengage tang of retainer from slot or flat of locknut, then remove locknut from housing tube, using J-2222, as shown in figure 65.

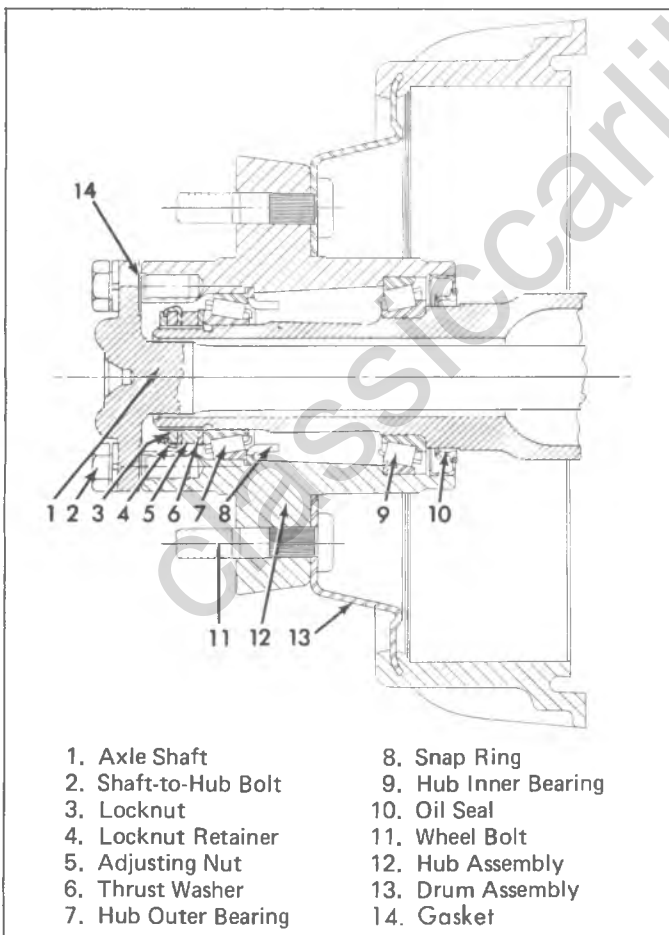

Fig. 64—Hub and Drum Assembly—10-1/2" Axles

3. Disengage tang of retainer from slot or flat of adjusting nut and remove retainer from housing tube.
4. Use appropriate tool as specified in Step 2 to remove adjusting nut from housing tube.

NOTE: Remove thrust washer from housing tube.

5. Pull hub and drum assembly straight off axle housing.
6. Remove oil seal, and discard.

#### Bearing/Cup—Removal

1. Use a hammer and long drift to knock the **inner** bearing, cup and oil seal from the hub assembly.
2. Remove **outer** bearing snap ring with a pair of pliers.
3. With J-24426 on Handle J-8092, as shown in figure 66, drive **outer** bearing and cup from the hub assembly.

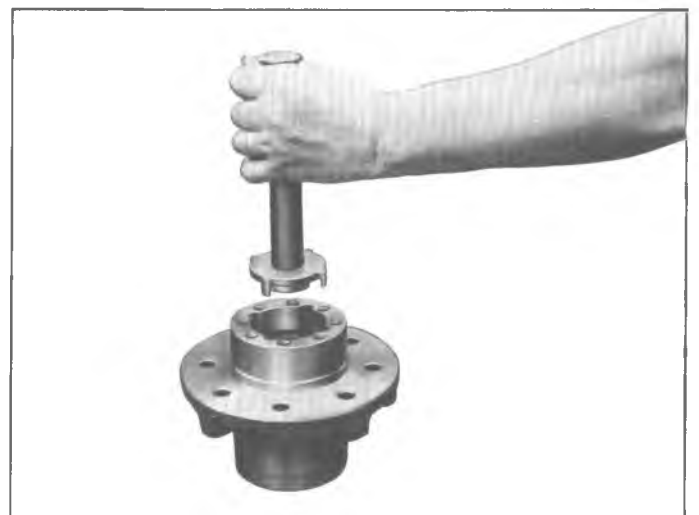

Fig. 66—Removing Outer Bearing and Cup

## 4-32 REAR SUSPENSION AND DRIVELINE

### Inspection and Cleaning of Bearings

1. Inspect bearing rollers for excessive wear, chipped edges, and other damage. Slowly move rollers around cone to detect any flat or rough spots on rollers or cone.
2. Examine bearing cups in hub for pits, cracks, and other damage.
3. Examine axle shaft flange studs, wheel studs, hub splines, hub bore, and tapped holes for evidence of damage. Clean up threads or replace parts where required.
4. Examine oil seal sleeve for evidence of wear or roughness, check axle housing oil deflector and brake drum oil deflector for evidence of damage. Replace parts where required.
5. Examine brake drum for excessive scoring and other damage. To replace brake drum refer to "Brake Drum Replacement."
6. Immerse bearing cone and roller assemblies in cleaning solvent. Clean with stiff brush to remove old lubricant. Blow bearings dry with compressed air, directing air stream across bearing. Do not spin bearings while blowing them dry.
7. Thoroughly remove all lubricant from axle housing tube and from inside the hub, wipe dry. Make sure all particles of gasket are removed from outer end of hub, axle shaft, and hub cap.
8. Scrape old sealing compound out of oil seal bore in the hub.

### Bearing/Cup—Installation

1. Place **outer** bearing into hub.
2. Install cup of outer bearing into hub by using Handle J-8092 and J-8608, **installed upside-down**. Be sure J-8608 is upside down on driver handle, so that chamfer does **not** contact bearing cup.
3. Drive cup **beyond** the snap ring groove.
4. Using a pair of pliers, install snap ring into its groove.
5. Drive cup back **against** snap ring by using J-24426, as shown in figure 66.
6. To install **inner** bearing cup, use J-24427 on Handle J-8092. Drive cup into place until it seats against shoulder of hub bore.
7. Install new oil seal with J-24428.

### Drum—Non-Demountable-Type—Fig. 64 Replacement

Construction of the nondemountable-type hub and drum assembly is such that replacement cannot be accomplished with the hub assembly installed on the vehicle.

1. Separate the drum and hub by removing the drum-to-hub retaining bolts, hub stud nuts, or by pressing out the wheel studs, as applicable.
2. Position brake drum to hub assembly, making

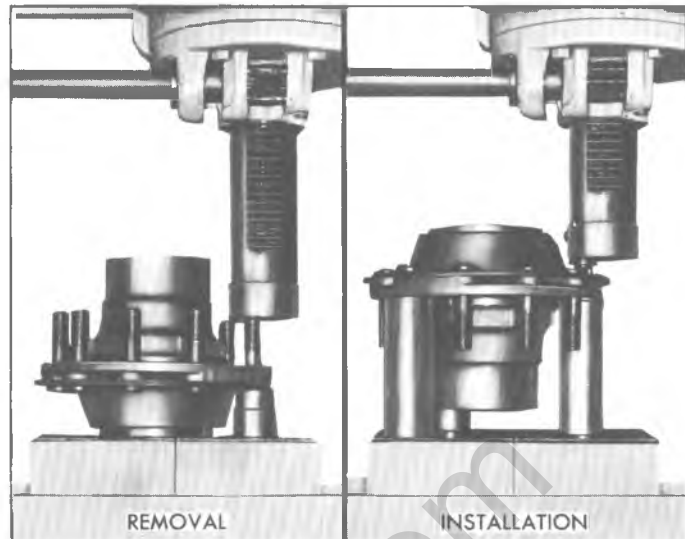

Fig. 67—Wheel Bolt Replacement

certain that all drain holes are in alignment.

3. Apply a light, even coating of sealing compound to the hub oil deflector contact surface, and position deflector to drum.
4. Install drum-to-hub retaining bolts, hub stud nuts, or press wheel studs into drum, as applicable.

### Wheel Bolt Replacement

Wheel bolts are serrated and may also be swaged in place; however, replacement procedure remains the same for both types of installation.

Press bolts out of hub flange and press new bolts into place, making sure they are a tight fit. If all bolts are removed, be sure that hub oil deflector is in position under bolt heads. See figure 67.

### Installation of Hub and Drum Assembly

1. Using a high melting point EP bearing lubricant, liberally pack bearings and apply a light coat on I.D. of hub bearing contact surface and O.D. of axle housing tube.
2. Make sure inner bearing, oil seal, axle housing oil deflector, and inner bearing race and oil seal are properly positioned.
3. Install hub and drum assembly on axle housing, exercising care so as not to damage oil seal or dislocate other internal components.
4. Install thrust washer so that tang on I.D. of washer is in keyway on axle housing.
5. Install adjusting nut and complete the installation as directed under "Bearing Adjustment."

### BEARING ADJUSTMENT

Before checking bearing adjustment, make sure brakes are fully released and do not drag.

Check bearing play by grasping tire at top and pulling

back and forth, or by using a pry bar under tire. If bearings are properly adjusted, movement of brake drum in relation to brake flange plate will be barely noticeable and wheel will turn freely. If movement is excessive, adjust bearing as follows:

1. Remove axle shaft and raise vehicle until wheel is free to rotate.
2. Disengage tang of retainer from locknut and remove both locknut and retainer from axle housing tube.
3. Using J-2222, tighten inner adjusting nut to specified torque at the same time rotating hub to make sure all bearing surfaces are in contact. Then back off inner nut to specified amount of turn-back.  
See figure 68, and refer to Specifications Section for torque values.
4. Install tanged retainer against the inner adjusting nut. Align inner adjusting nut so short tang of retainer will engage nearest slot on inner adjusting nut.
5. Install outer locknut and tighten to correct specified torque. Then bend long tang of retainer into slot of outer nut. This method of adjustment will result in the proper bearing adjustment.

**DRIVE PINION OIL SEAL**

**Replacement**

NOTE: The pinion oil seal may be replaced with the carrier assembly installed in the vehicle.

1. Disconnect propeller shaft.
2. Scribe a line down the pinion stem, pinion nut and companion flange.
3. Use J-8614-11 to remove the pinion nut and the companion flange.
4. Pry the oil seal from the bore, using care not to damage the machined surfaces. Thoroughly clean all foreign material from contact area.



Fig. 68—Tightening Adjusting Nut—Typical

5. Lubricate the cavity between the seal lips with a high melting point bearing lubricant.
6. Install a new pinion oil seal into the bore, using J-24434.
7. Reinstall the companion flange, pinion nut and propeller shaft.

**CAUTION:** See CAUTION on page 1 of this section, regarding the above fasteners.

**DANA 10-1/2 RING GEAR AXLE  
DANA 9-3/4 RING GEAR  
AXLE**

Procedures for service to axle assembly, axle shafts, hub and drum components and bearing adjustments are identical to those listed for "Chevrolet 10-1/2 Ring Gear Axle".

Drive pinion oil seal replacement requires different special tools for the Dana axles. Follow the same procedure listed for "Chevrolet 10-1/2" Ring Gear Axle"; use J-24384 for seal replacement on Dana 10-1/2" Ring Gear Axles, and use J-22281 for pinion oil seal replacement on Dana 9-3/4" Ring Gear Axles.

**12-1/4 RING GEAR AXLE**

**AXLE ASSEMBLY**

The axle assembly removal and installation is identical to the procedure given earlier for "Chevrolet 10-1/2" Ring Gear Axle".

**AXLE VENT**

**Replacement**

Service replacement axle housing assemblies are not equipped with an axle vent; therefore, always make sure that a new vent assembly is installed when replacing the housing. If axle vent requires replacement, pry old vent from housing being sure that entire vent is removed. Prick punch around carrier hole to insure fit of replacement vent. Tap new vent into housing using a

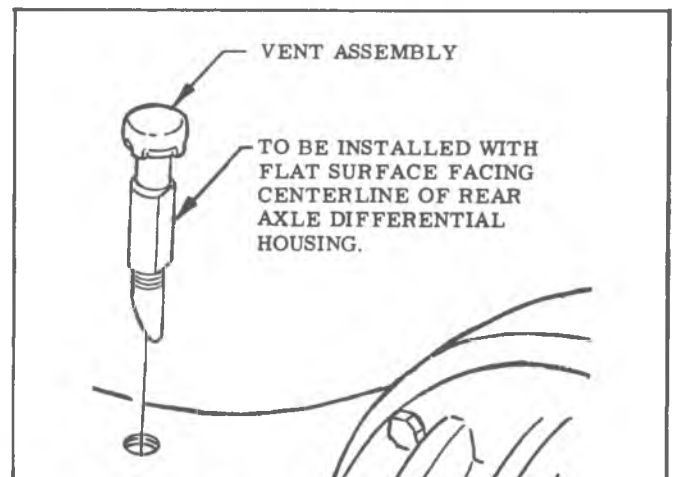

Fig. 69—Typical Axle Vent Installation

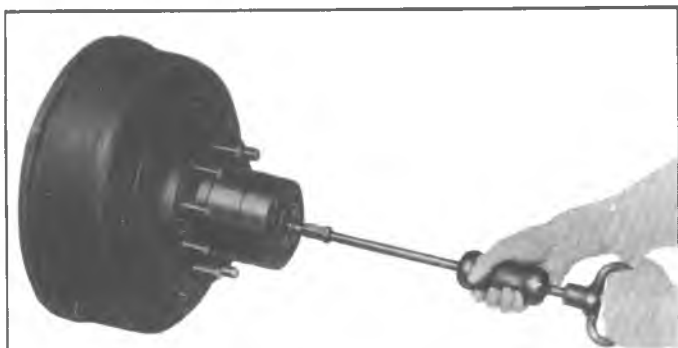

Fig. 70—Removing Axle Shaft—11,000 # Axle

soft-faced hammer. Vent should be positioned in housing so that flat surface is toward centerline of differential carrier. See figure 69.

### AXLE SHAFT

#### Replacement

1. Remove hub cap, and install Tool J-8117 in tapped hole on shaft flange.
2. Install slide hammer, Tool J-2619, and remove axle shaft, as shown in figure 70.
3. Thoroughly remove old gasket material from hub and hub cap. Clean shaft flange and mating surfaces in the wheel hub.

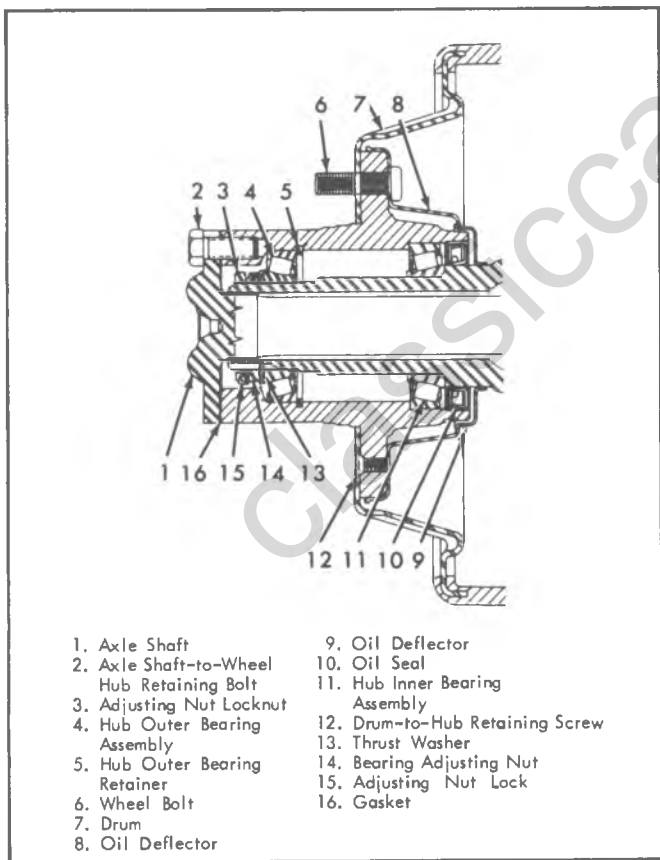

- |   |                                 |
|---|---------------------------------|
| 1. Axle Shaft                             | 9. Oil Deflector                |
| 2. Axle Shaft-to-Wheel Hub Retaining Bolt | 10. Oil Seal                    |
| 3. Adjusting Nut Locknut                  | 11. Hub Inner Bearing Assembly  |
| 4. Hub Outer Bearing Assembly             | 12. Drum-to-Hub Retaining Screw |
| 5. Hub Outer Bearing Retainer             | 13. Thrust Washer               |
| 6. Wheel Bolt                             | 14. Bearing Adjusting Nut       |
| 7. Drum                                   | 15. Adjusting Nut Lock          |
| 8. Oil Deflector                          | 16. Gasket                      |

Fig. 71—Hub and Drum Assembly—12-1/4" Axles—11,000 #

4. Install axle shaft so that the flange splines index into hub splines. Tap shaft into position, using J-8117 and J-2619.
5. Install new gasket, position flange to hub and install attaching bolts. Torque bolts to specifications.

### HUB AND DRUM ASSEMBLY—FIG. 71

#### Removal

Use the procedure given for "Chevrolet 10-1/2" Ring Gear Axle", and use J-0870 to remove the adjusting nut. Refer to figure 65.

#### Bearing Cup—Removal

1. Cut a suitable length of 1/2 inch steel bar stock for press-out tool as shown in figure 72.
2. Place bar stock tool behind inner bearing cup, index tool in provided notches, and press out cup with an arbor press.
3. Use J-22380, as shown in figure 73, to remove outer bearing retainer ring.
4. Remove the outer bearing by driving on the axle shaft spacer, using the splined flange cut from an old axle shaft, as shown in figure 74.

#### Inspection and Cleaning of Bearings

Refer to procedures listed for "Chevrolet 10-1/2" Ring Gear Axle.

#### Bearing Cup—Installation

1. To install **outer** bearing, place axle shaft spacer in hub, followed by the outer bearing. The larger O.D. of the bearing goes toward the outer end of the hub.
2. Position outer bearing cup in hub with the thin edge of the cup toward the outer end of the hub.
3. Press the cup into the hub, using J-8114 and Handle J-8092.

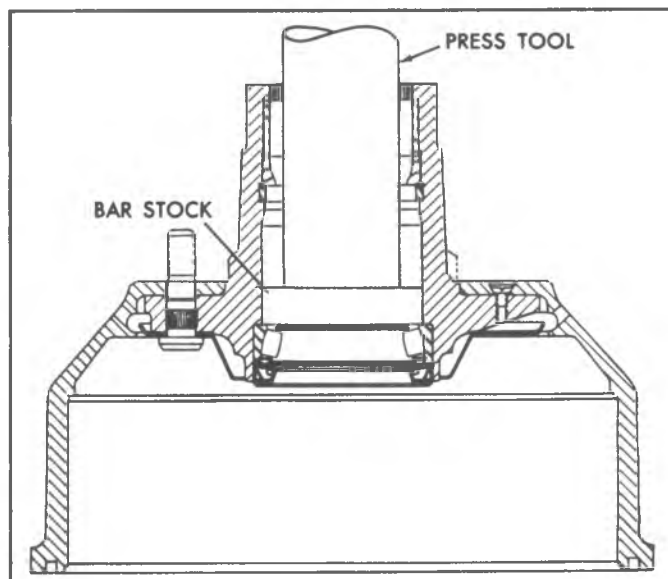

Fig. 72—Removing Hub Inner Bearing Cup

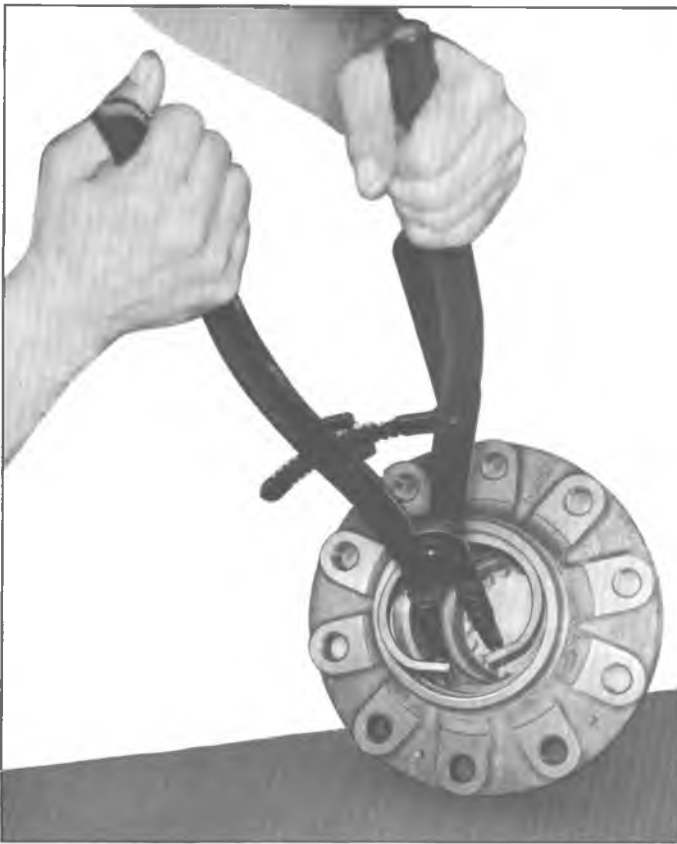

Fig. 73—Removing Hub Outer Bearing Retainer Ring

4. Withdraw cup installer, then install retainer ring, using J-22380 as shown in figure 73. Press the cup into contact with the retainer ring as shown in figure 74.

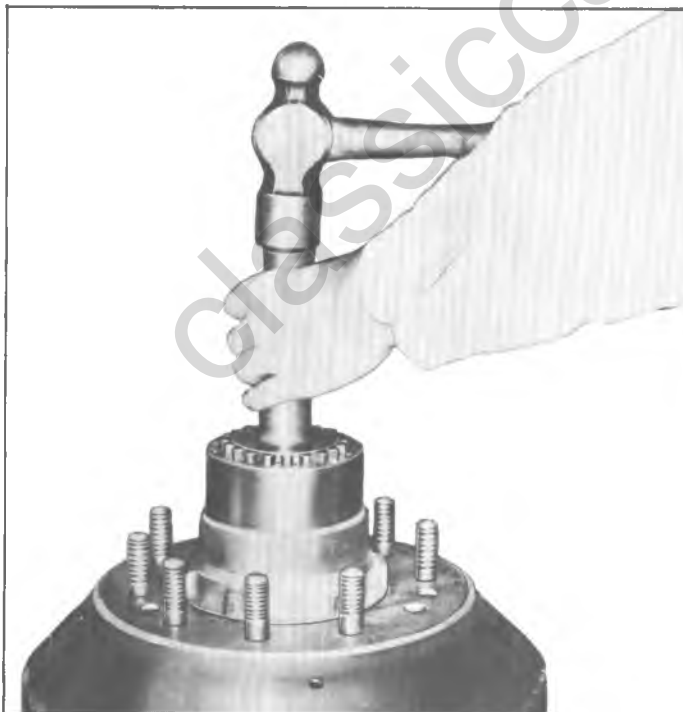

Fig. 74—Removing Hub Outer Bearing



Fig. 75—Installing Hub Inner Bearing Cup

NOTE: The bearing cup-to-retainer ring seating procedure is essential to assure that an accurate wheel bearing adjustment will be obtained, and that the adjustment will not loosen during vehicle operation.

5. To install **inner** bearing, use J-8093 with Handle J-8092 to drive cup into hub bore, as shown in figure 75.
6. Install new oil seal, using J-22354 as shown in figure 76.

## DRUM—DEMOUNTABLE-TYPE—FIG. 71

### Replacement

The demountable-type drum may be separated from the hub and removed from the vehicle without disturbing the axle shaft and hub. The drum is held to the hub by



Fig. 76—Installing Hub Oil Seal

## 4-36 REAR SUSPENSION AND DRIVELINE

countersunk, slotted screws, which are easily removed with a screw driver.

### WHEEL BOLT REPLACEMENT

Refer to figure 67 and to procedure listed under "Chevrolet 10-1/2" Ring Gear Axle.

### INSTALLATION OF HUB AND DRUM ASSEMBLY

1. Using a high melting point EP bearing lubricant, liberally pack bearings and apply a light coat on I.D. of hub bearing contact surface and O.D. of axle housing tube.
2. Make sure inner bearing, oil seal, axle housing oil deflector, and inner bearing race and oil seal are properly positioned.
3. Install hub and drum assembly on axle housing, exercising care so as not to damage oil seal or dislocate other internal components.
4. Place outer bearing cone and roller assembly on axle housing and press firmly into hub with hand.
5. Install adjusting nut and complete the installation as directed under "Bearing Adjustment".

### BEARING ADJUSTMENT

Before checking bearing adjustment, make sure brakes are fully released and do not drag.

Check bearing play by grasping tire at top and pulling back and forth, or by using a pry bar under tire. If bearings are properly adjusted, movement of brake drum in relation to brake flange plate will be barely noticeable and wheel will turn freely. If movement is excessive, adjust bearing as follows:

1. Remove axle shaft and raise vehicle until wheel is free to rotate.
2. Disengage tang of retainer from locknut and remove both locknut and retainer from axle housing tube.
3. Use J-0870 to tighten inner adjusting nut to specified torque at the same time rotating hub to make sure all bearing surfaces are in contact. Then back off inner nut to specified amount of turn-back.

See figure 68, and refer to Specifications Section for torque values.

4. Install tanged retainer against the inner adjusting nut. Align inner adjusting nut so short tang of retainer will engage nearest slot on inner adjusting nut.
5. Install outer locknut and tighten to correct specified torque. Then bend long tang of retainer into slot of outer nut. This method of adjustment will result in the proper bearing adjustment.

### DRIVE PINION OIL SEAL

#### Replacement

NOTE: The pinion oil seal may be replaced with the carrier assembly installed in the vehicle.

1. Disconnect propeller shaft.
2. Scribe a line down the pinion stem, pinion nut and companion flange.
3. Use J-8614-11 to remove the pinion nut and the companion flange.
4. Remove the bolts retaining the oil seal retainer to the carrier, and remove the retainer. See figure 77.
5. Pry the oil seal from the bore, using care not to damage the machined surfaces. Thoroughly clean all foreign material from contact area.
6. Lubricate the cavity between the seal lips with a high melting point bearing lubricant.
7. Install a new pinion oil seal into the bore, using J-22281. Be sure seal bottoms against shoulder in bore.
8. Install the bearing retainer to the carrier.
9. Reinstall the companion flange, pinion nut and propeller shaft.

**CAUTION:** See CAUTION on page 1 of this section, regarding the above fasteners.

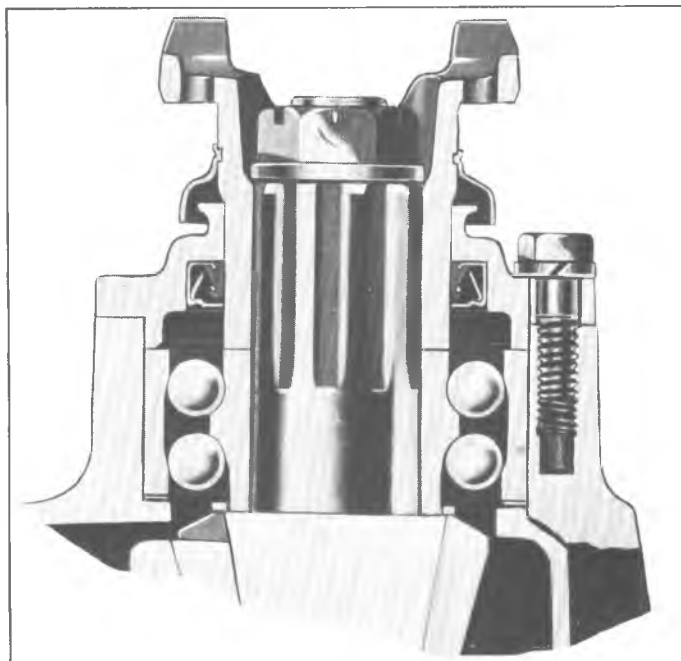

Fig. 77—Pinion Oil Seal—12-1/4" Axle



## DIFFERENTIAL DIAGNOSIS

### STANDARD DIFFERENTIAL

#### Noise

The most essential part of rear axle service, as with any mechanical repair, is proper diagnosis of the problem, and, in axle work one of the most difficult areas to diagnosis is noise. Locating a broken axle shaft, or broken differential gear, presents little or no problem, but, locating and isolating axle noise can be an entirely different matter.



Fig. 78—Noise Level

#### Degree of Noise

Any gear driven unit, and especially an automotive drive axle where engine torque multiplication occurs at a 90° turn in the drive line, produces a certain amount of noise. Therefore, an interpretation must be made for each vehicle to determine whether the noise is normal or if a problem actually exists. A normal amount of noise must be expected and cannot be eliminated by conventional repairs or adjustment. See figure 78.

Acceptable noise can be defined as a slight noise heard only at a certain speed or under unusual or remote conditions. For example, this noise tends to reach a "peak" at speeds from 40 to 60 miles per hour depending on road and load conditions, or on gear ratio and tire size. This slight noise is in no way indicative of trouble in the axle assembly.

Drive line noises may baffle even the best diagnostician. Vehicle noises coming from tires, transmission, propeller shaft, universal joints, and front or rear wheel bearings, are often mistaken for axle noise. Such practices as: raising tire pressure to eliminate tire noise (although this will not silence tread noise of mud and snow tires), listening for the noise at varying speeds and road surfaces, on drive, float, and coast conditions will aid in locating the source of alleged axle noises. Thus, every effort should be made to isolate the noise to a specific drive line component instead of making a random guess that could be a costly waste of time.

### Elimination of External Noises

When a rear axle is suspected of being noisy, it is advisable to make a thorough test to determine whether the noise originates in the tires, road surface, front wheel bearings, engine, transmission, or rear axle assembly. Noise which originates in other places cannot be corrected by adjustment or replacement of parts in the rear axle assembly.

**Road Noise**—Some road surfaces, such as brick or rough-surfaced concrete, cause noise which may be mistaken for tire or rear axle noise. Driving on a different type of road, such as smooth asphalt or dirt, will quickly show whether the road surface is the cause of noise. Road noise usually is the same on drive or coast.

**Tire Noise**—Tire noise may easily be mistaken for rear axle noise, even though the noisy tires may be located on the front wheels. Tires worn unevenly, or having surfaces on non-skid divisions worn in saw-tooth fashion, are usually noisy and may produce vibrations which seem to originate elsewhere in the vehicle. This is particularly true with low tire pressure.

**Test for Tire Noise**—Tire noise changes with different road surfaces, but rear axle noise does not. Temporarily inflating all tires to approximately 50 pounds pressure, **for test purposes only** will materially alter noise caused by tires but will not affect noise caused by the rear axle. Rear axle noise usually ceases when coasting at speeds under 30 miles per hour; however, tire noise continues but with lower tone as vehicle speed is reduced. Rear axle noise usually changes when comparing "pull" and "coast" but tire noise remains about the same.

**Engine and Transmission Noises**—Sometimes a noise which seems to originate in the rear axle is actually caused by the engine or transmission. To determine which unit is actually causing the noise, observe approximate car speeds and conditions under which the noise is most pronounced; then stop vehicle in a quiet place to avoid interfering noises. With transmission in neutral, run engine slowly up and down through engine speeds corresponding to vehicle speed at which the noise was most pronounced. If a similar noise is produced with vehicle standing, it is caused by the engine or transmission and not the rear axle.

**Front Wheel Bearing Noise**—Loose or rough front wheel bearings will cause noise which may be confused with rear axle noises; however, front wheel bearing noise does not change when comparing "pull" and "coast". Light application of brake, while holding vehicle speed steady, will often cause wheel bearing noise to diminish, as this takes some weight off the bearing. Front wheel bearings may be easily checked for noise by jacking up the wheels and spinning them, and also by shaking wheels to determine if bearings are excessively loose.

### Body Boom Noise or Vibration

Objectional "body boom" noise or vibration at 55-65 mph can be caused by an unbalanced propeller shaft. Excessive looseness at the spline can contribute to this unbalance.

Other items that may also contribute to the noise problem are as follows:

1. Undercoating or mud on the shaft, causing unbalance.
2. Shaft or companion flange balance weights missing.
3. Shaft damage, such as bending, dents, or nicks.
4. Tire-type roughness. Switch tires from a known good car to determine tire fault.

If, after making a comprehensive check of the vehicle, all indications point to the rear axle, further diagnostic steps are necessary to determine the axle components at fault. True axle noises generally fall into two categories: gear noise and bearing noise.

### Rear Axle Noises

If a careful test of vehicle shows that noise is not caused by external items it is then reasonable to assume that noise is caused by rear axle assembly. The rear axle should be tested on a smooth level road to avoid road noise. It is not advisable to test rear axle for noise by running with rear wheels jacked up.

Noises in rear axle assembly may be caused by a faulty propeller shaft, faulty rear wheel bearings, faulty differential or pinion shaft bearings, misalignment between two U-joints, or worn differential side gears and pinions; noises may also be caused by mismatched, improperly adjusted, or scored ring and pinion gear set.

**Rear Wheel Bearing Noise**—A rough rear wheel bearing produces a vibration or growl which continues with vehicle coasting and transmission in neutral. A brinelled rear wheel bearing causes a knock or click approximately every two revolutions of rear wheel, since the bearing rollers do not travel at the same speed as the rear axle and wheel. With rear wheels jacked up, spin rear wheels by hand while listening at hubs for evidence of rough or brinelled wheel bearing.

**Differential Side Gear and Pinion Noise**—Differential side gears and pinions seldom cause noise since their movement is relatively slight on straight ahead driving. Noise produced by these gears will be most pronounced on turns.

**Pinion Bearing** failures can be distinguished because they rotate at higher speeds than differential side bearings and axle shaft bearings. Rough or brinelled pinion bearings produce a continuous low pitched whirring or scraping noise starting at relatively low speed.

**Side Bearings** produce a constant rough noise of a lower pitch than pinion bearings. Side bearing noise may also fluctuate in the above wheel bearing test.

NOTE: Bearing Diagnosis Charts appear later in this section.

### Gear Noise

There are two basic types of gear noise. The first type is produced by broken, bent, or forcibly damaged gear teeth and is usually quite audible over the entire speed range and presents no particular problem in diagnosis.

For example, hypoid gear tooth scoring as seen in figure 79 generally results from the following: insufficient lubricant improper breakin, improper lubricant, insufficient gear backlash, improper ring and pinion gear alignment, or loss of drive pinion nut torque. The scoring will progressively lead to complete erosion of the gear tooth, or gear tooth pitting and eventual fracture if the initial scoring condition is not corrected. Another cause of hypoid tooth fracture is extended overloading of the gear set which will produce fatigue fracture, or shock loading which will result in sudden failure.

Differential pinion and side gears rarely give trouble. Common causes of differential failure are shock loading, extended overloading, and seizure of the differential pinions to the cross shaft resulting from excessive wheel spin and consequent lubrication breakdown.

The second type of gear noise pertains to the mesh pattern of the gear teeth. This form of abnormal gear

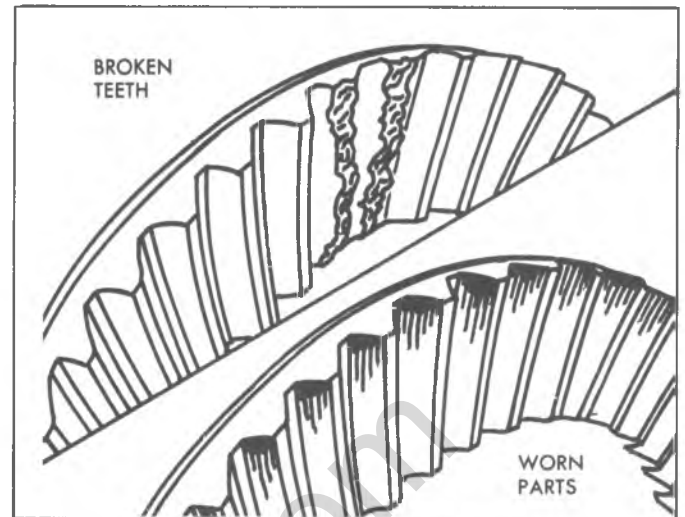

Fig. 79—Two Causes of Gear Noise

noise can be recognized as it produces a cycling pitch (whine) and will be very pronounced in the speed range at which it occurs, appearing under either "drive", "float" or "coast" conditions. "Drive" is acceleration or heavy pull. "Coast" is with a closed throttle and vehicle in gear and "float" is using just enough throttle to keep the car from driving the engine—the vehicle slows down gradually but engine still pulls slightly. Gear noise tends to peak in a narrow speed range or ranges, and will tend to remain constant in pitch. Bearing noise will vary in pitch with vehicle speeds. See figure 80.

## 4-40 REAR SUSPENSION AND DRIVELINE

### A GENERAL DIAGNOSTIC PROCEDURE FOR ISOLATING REAR AXLE NOISE PROBLEMS

Problem	Cause
1. Noise is the same in drive or coast	1. a) Road noise b) Tire noise c) Front wheel bearing noise
2. Noise changes on a different type of road	2. a) Road noise b) Tire noise
3. Noise tone lowers as car speed is lowered	3. Tire noise
4. Similar noise is produced with car standing and driving	4. a) Engine noise b) Transmission noise
5. Vibration	5. a) Rough rear wheel bearing b) Unbalanced or damaged propeller shaft c) Tire unbalance d) Worn universal joint in propeller shaft e) Mis-indexed propeller shaft at companion flange f) Companion flange runout too great
6. A knock or click approximately every two revolutions of rear wheel	6. A brinelled rear wheel bearing
7. Noise most pronounced on turns	7. Differential side gear and pinion
8. A continuous low pitch whirring or scraping noise starting at relatively low speed	8. Pinion bearing
9. Drive noise, coast noise or float noise	9. Ring and pinion gear
10. Clunk on acceleration or deceleration	10. Worn differential cross shaft in case
11. Grunt on stops	11. No grease in propeller shaft slip yoke
12. Groan in Forward or Reverse	12. Wrong lube in differential
13. Chatter on turns	13. a) Wrong lube in differential b) Clutch plates worn
14. Clunk or knock on rough road operation	14. Excessive end play of axle shafts to differential cross shaft

Fig. 80—Diagnosis of Noise Problems

# DIFFERENTIAL AND REAR AXLE BEARING DIAGNOSIS

CONSIDER THE FOLLOWING FACTORS WHEN DIAGNOSING BEARING CONDITION

- 1 GENERAL CONDITION OF ALL PARTS DURING DISASSEMBLY AND INSPECTION.
- 2 CLASSIFY THE FAILURE WITH THE AID OF THE ILLUSTRATIONS.
- 3 DETERMINE THE CAUSE.
- 4 MAKE ALL REPAIRS FOLLOWING RECOMMENDED PROCEDURES









 <p><b>ABRASIVE ROLLER WEAR</b></p> <p>PATTERN ON RACES AND ROLLERS CAUSED BY FINE ABRASIVES</p> <p>CLEAN ALL PARTS AND HOUSINGS. CHECK SEALS AND BEARINGS AND REPLACE IF LEAKING, ROUGH OR NOISY.</p>	 <p><b>GALLING</b></p> <p>METAL SMEARS ON ROLLER ENDS DUE TO OVERHEAT, LUBRICANT FAILURE OR OVERLOAD (WAGON'S)</p> <p>REPLACE BEARING. CHECK SEALS AND CHECK FOR PROPER LUBRICATION</p>	 <p><b>BENT CAGE</b></p> <p>CAGE DAMAGE DUE TO IMPROPER HANDLING OR TOOL USAGE</p> <p>REPLACE BEARING</p>
 <p><b>ABRASIVE STEP WEAR</b></p> <p>PATTERN ON ROLLER ENDS CAUSED BY FINE ABRASIVES</p> <p>CLEAN ALL PARTS AND HOUSINGS. CHECK SEALS AND BEARINGS AND REPLACE IF LEAKING, ROUGH OR NOISY</p>	 <p><b>ETCHING</b></p> <p>BEARING SURFACES APPEAR GRAY OR GRAYISH BLACK IN COLOR WITH RELATED ETCHING AWAY OF MATERIAL USUALLY AT ROLLER SPACING</p> <p>REPLACE BEARINGS. CHECK SEALS AND CHECK FOR PROPER LUBRICATION</p>	 <p><b>BENT CAGE</b></p> <p>CAGE DAMAGE DUE TO IMPROPER HANDLING OR TOOL USAGE</p> <p>REPLACE BEARING</p>
 <p><b>INDENTATIONS</b></p> <p>SURFACE DEPRESSIONS ON RACE AND ROLLERS CAUSED BY HARD PARTICLES OF FOREIGN MATERIAL.</p> <p>CLEAN ALL PARTS AND HOUSINGS. CHECK SEALS AND REPLACE BEARINGS IF ROUGH OR NOISY</p>	 <p><b>CAGE WEAR</b></p> <p>WEAR AROUND OUTSIDE DIAMETER OF CAGE AND ROLLER POCKETS CAUSED BY ABRASIVE MATERIAL AND INEFFICIENT LUBRICATION</p> <p>CLEAN RELATED PARTS AND HOUSINGS. CHECK SEALS AND REPLACE BEARINGS.</p>	 <p><b>MISALIGNMENT</b></p> <p>OUTER RACE MISALIGNMENT DUE TO FOREIGN OBJECT</p> <p>CLEAN RELATED PARTS AND REPLACE BEARING. MAKE SURE RACES ARE PROPERLY SEATED</p>

Fig. 81—Differential and Axle Bearing Diagnosis Chart A

## DIFFERENTIAL AND REAR AXLE BEARING DIAGNOSIS (CONT'D)

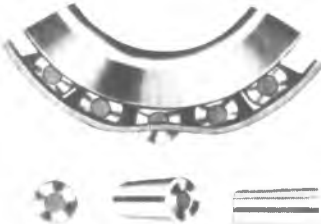





 <p style="text-align: center;"><b>CRACKED INNER RACE</b></p> <p>RACE CRACKED DUE TO IMPROPER FIT, COCKING, OR POOR BEARING SEATS.</p> <p>REPLACE BEARING AND CORRECT BEARING SEATS.</p>	 <p style="text-align: center;"><b>FATIGUE SPALLING</b></p> <p>FLAKING OF SURFACE METAL RESULTING FROM FATIGUE.</p> <p>REPLACE BEARING -- CLEAN ALL RELATED PARTS.</p>	 <p style="text-align: center;"><b>BRINELLING</b></p> <p>SURFACE INDENTATIONS IN RACEWAY CAUSED BY ROLLERS EITHER UNDER IMPACT LOADING OR VIBRATION WHILE THE BEARING IS NOT ROTATING.</p> <p>REPLACE BEARING IF ROUGH OR NOISY.</p>
 <p style="text-align: center;"><b>FRETTAGE</b></p> <p>CORROSION SET UP BY SMALL RELATIVE MOVEMENT OF PARTS WITH NO LUBRICATION.</p> <p>REPLACE BEARING. CLEAN RELATED PARTS. CHECK SEALS AND CHECK FOR PROPER LUBRICATION</p>	 <p style="text-align: center;"><b>STAIN DISCOLORATION</b></p> <p>DISCOLORATION CAN RANGE FROM LIGHT BROWN TO BLACK CAUSED BY INCORRECT LUBRICANT OR MOISTURE.</p> <p>RE USE BEARINGS IF STAINS CAN BE REMOVED BY LIGHT POLISHING OR IF NO EVIDENCE OF OVER HEATING IS OBSERVED.</p> <p>CHECK SEALS AND RELATED PARTS FOR DAMAGE.</p>	 <p style="text-align: center;"><b>HEAT DISCOLORATION</b></p> <p>HEAT DISCOLORATION CAN RANGE FROM FAINT YELLOW TO DARK BLUE RESULTING FROM OVER LOAD (WAGON'S) OR INCORRECT LUBRICANT.</p> <p>EXCESSIVE HEAT CAN CAUSE SOFTENING OF RACES OR ROLLERS.</p> <p>TO CHECK FOR LOSS OF TEMPER ON RACES OR ROLLERS A SIMPLE FILE TEST MAY BE MADE. A FILE DRAWN OVER A TEMPERED PART WILL GRAB AND CUT METAL, WHEREAS, A FILE DRAWN OVER A HARD PART WILL GLIDE READILY WITH NO METAL CUTTING.</p> <p>REPLACE BEARINGS IF OVER HEATING DAMAGE IS INDICATED. CHECK SEALS AND OTHER PARTS.</p>
 <p style="text-align: center;"><b>SMEARS</b></p> <p>SMEARING OF METAL DUE TO SLIPPAGE. SLIPPAGE CAN BE CAUSED BY POOR FITS LUBRICATION, OVERHEATING, OVERLOADS OR HANDLING DAMAGE.</p> <p>REPLACE BEARINGS, CLEAN RELATED PARTS AND CHECK FOR PROPER FITS AND LUBRICATION</p>		

Fig. 82—Differential and Axle Bearing Diagnosis Chart B

## SPECIAL TOOLS

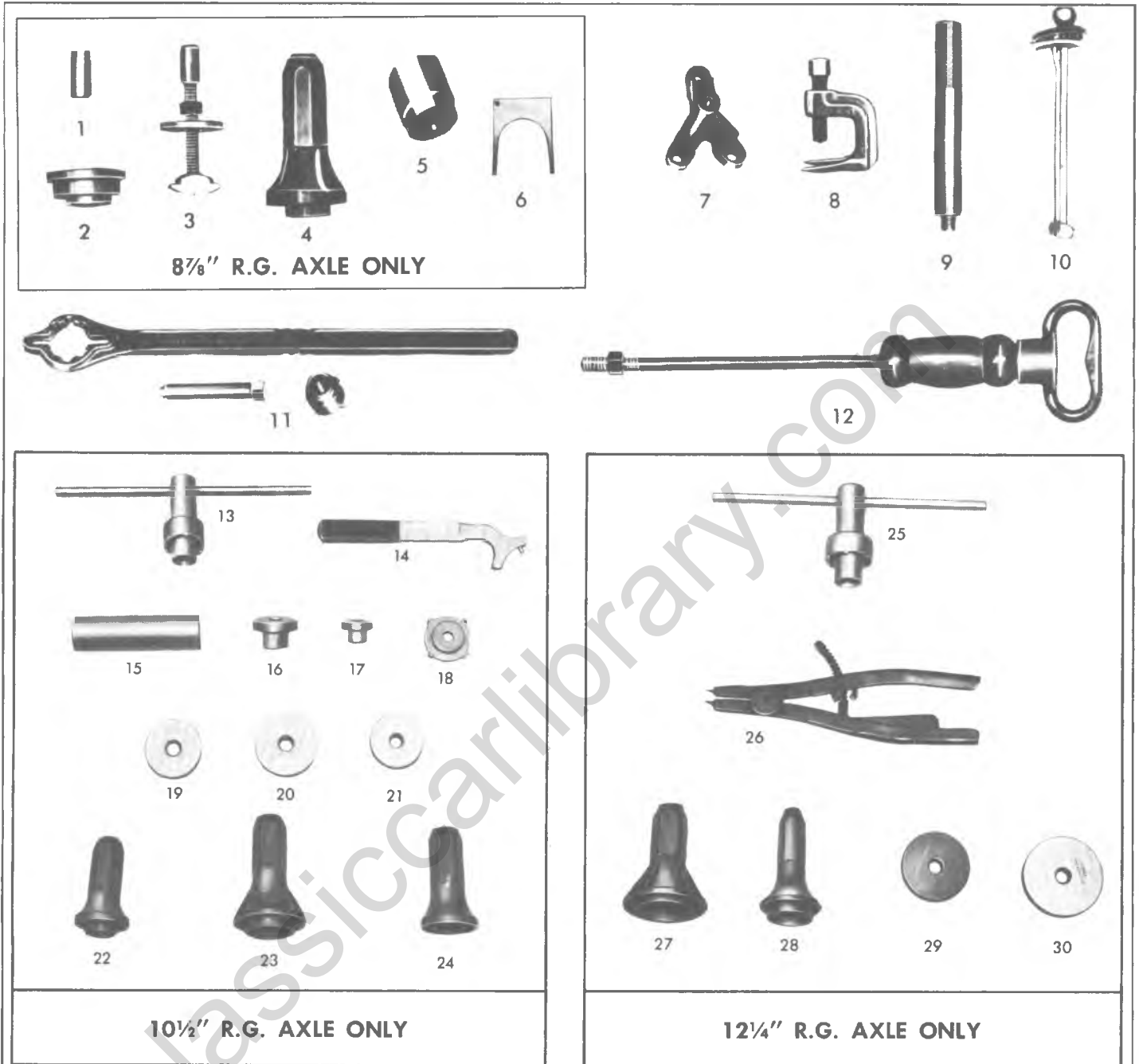

8 7/8" R.G. AXLE ONLY

10 1/2" R.G. AXLE ONLY

12 1/4" R.G. AXLE ONLY

- |               |                                       |             |                                       |
|---------------|---------------------------------------|-------------|---------------------------------------|
| 1. J-21548    | Trunnion Seal Installer               | 16. J-24430 | Differential Side Bearing Installer   |
| 2. J-23690    | Axle Shaft Bearing Installer          | 17. J-23322 | Pinion Straddle Bearing Installer     |
| 3. J-23689    | Axle Shaft Bearing Remover            | 18. J-24426 | Outer Wheel Bearing Cup Tool          |
| 4. J-21128    | Axle Shaft Seal Installer             | 19. J-24432 | Pinion Rear Bearing Cup Installer     |
| 5. J-21057    | Pinion Oil Seal Installer             | 20. J-24427 | Inner Wheel Bearing Cup Installer     |
| 6. J-22804-1  | Pinion Seal Gauge Plate               | 21. J-8608  | Outer Wheel Bearing Cup Installer     |
| 7. J-5748     | Positraction Torque Measuring Adapter | 22. J-24384 | Pinion Oil Seal Installer - Dana      |
| 8. J-6627     | Wheel Bolt Remover                    | 23. J-24428 | Wheel Hub Oil Seal Installer          |
| 9. J-8092     | Driver Handle                         | 24. J-24434 | Pinion Oil Seal Installer - Chevrolet |
| 10. J-5853    | Torque Wrench - Inch/Pound            | 25. J-870   | Wheel Bearing Nut Wrench              |
| 11. J-8614-II | Companion Flange Holder               | 26. J-22380 | Tru-Arc Pliers                        |
| 12. J-2619    | Slide Hammer                          | 27. J-22354 | Wheel Oil Seal Installer              |
| 13. J-2222    | Wheel Bearing Nut Wrench              | 28. J-22281 | Pinion Oil Seal Installer             |
| 14. J-24429   | Adjusting Nut Wrench                  | 29. J-8114  | Wheel Bearing Outer Cup Installer     |
| 15. J-24433   | Pinion Rear Bearing Installer         | 30. J-8093  | Wheel Bearing Inner Cup Installer     |

Fig. 83—Special Tools

classiccarylbrary.com



## SECTION 5

# BRAKES

The following caution applies to one or more steps in the assembly procedure of components in this portion of the manual as indicated at appropriate locations by the terminology "See Caution on page 1 of this section."

**CAUTION: THIS FASTENER IS AN IMPORTANT ATTACHING PART IN THAT IT COULD AFFECT THE PERFORMANCE OF VITAL COMPONENTS AND SYSTEMS, AND/OR COULD RESULT IN MAJOR REPAIR EXPENSE. IT MUST BE REPLACED WITH ONE OF THE SAME PART NUMBER OR WITH AN EQUIVALENT PART IF REPLACEMENT BECOMES NECESSARY. DO NOT USE A REPLACEMENT PART OF LESSER QUALITY OR SUBSTITUTE DESIGN. TORQUE VALUES MUST BE USED AS SPECIFIED DURING REASSEMBLY TO ASSURE PROPER RETENTION OF THIS PART.**

### CONTENTS OF THIS SECTION

Standard Brakes .....	5-1
Vacuum Power Brakes .....	5-57
Hydro-boost Brakes.....	5-67
Special Tools .....	5-83

## STANDARD BRAKES

### INDEX

General Description .....	5-2	Parking Brake Adjustment.....	5-23
Master Cylinder.....	5-2	Parking Brake (Propeller Shaft) Adjustment .....	5-23
Combination Valve.....	5-2	Component Replacement and Repair .....	5-24
Disc Brakes Front.....	5-2	Shoes and Linings--Rear Drum Brakes.....	5-24
Drum Brakes Rear.....	5-2	Anchor Pin Replacement.....	5-27
Theory of Operation.....	5-4	Wheel Cylinder.....	5-27
Hydraulic System.....	5-4	Brake Drum Refinishing.....	5-28
Pressure and Force.....	5-5	Shoe and Linings--Front Disc Brakes.....	5-29
Brake System Components.....	5-5	Caliper Overhaul.....	5-32
Operation of Brake Mechanism .....	5-9	Disc Refinishing.....	5-34
Front Disc Brakes.....	5-10	Master Cylinder.....	5-36
Rear Drum Brakes.....	5-12	Master Cylinder Overhaul.....	5-36
Maintenance and Adjustment.....	5-15	Bench Bleeding Master Cylinder.....	5-38
Brake Inspection.....	5-15	Brake Combination Valve.....	5-38
Hydraulic Brake Fluid.....	5-16	Brake Pedal--Service Brake .....	5-39
Bleeding Hydraulic System.....	5-16	Parking Brake Pedal.....	5-40
Pressure Bleeding.....	5-17	Parking Brake Cables.....	5-40
Manual Bleeding.....	5-18	Parking Brake--Propeller Shaft.....	5-40
Hydraulic Brake Lines and Tubing.....	5-19	Rear Brakes--R.P.O. H-22.....	5-43
Drum Brake Adjustment.....	5-21	Diagnosis.....	5-46
Brake Pedal Free Travel Adjustment.....	5-22	Inspection .....	5-46
Stoplamp Switch Adjustment.....	5-22	Preliminary Checks.....	5-46
		Road Testing.....	5-47

## GENERAL DESCRIPTION

All vehicles are equipped with a dual hydraulic brake system.

The split system consists basically of two separate brake systems. When a failure is encountered on either, the other is adequate to stop the vehicle. If one system is not functioning, it is normal for the brake pedal lash and pedal effort to substantially increase. This occurs because of the design of the master cylinder which incorporates an actuating piston for each system. When the rear system loses fluid, its piston will bottom against the front piston. When the front system loses fluid, its piston will bottom on the end of the master cylinder body. The pressure differential in one of the systems causes an uneven hydraulic pressure balance between the front and rear systems. The combination valve (near the master cylinder) detects the loss of pressure and illuminates the brake alarm indicator light on the instrument panel. The pressure loss is felt at the brake pedal by an apparent lack of brakes for most of the brake travel and then, when failed chamber is bottomed, the pedal will harden.

If a vehicle displays these symptoms, it is a good indication that one of the systems contains air or has failed, and it is necessary to bleed or repair the brakes.

### MASTER CYLINDER (Fig. 1)

The system is designed with a separate hydraulic system for the front and rear brakes using a dual master cylinder. The cylinder has two separate reservoirs and outlets in a common body casting. On all C-K10, G10 Power and P10 Manual brake vehicles, the front reservoir controls the front brake system and the rear reservoir controls the rear system. On all other series vehicles, the front reservoir controls the rear brake system and the rear reservoir controls the front system.

### COMBINATION VALVE

All models have a combination valve. The combination

valve is located below the master cylinder on P models (without Hydro-boost), on the crossmember on C-K models and P models (with Hydro-boost) or on the frame rail on G models. The front and rear hydraulic lines are routed through this combination "metering" and "brake failure warning switch" to their appropriate wheel cylinders or caliper.

The metering portion of the combination valve tends to "hold off" front hydraulic pressure until the rear brake system overcomes their pull back springs; then pressure is allowed to flow with the result being a good distribution of braking effort.

The brake failure warning switch portion of the combination valve "senses" a loss of hydraulic pressure, if a failure should occur and turns "on" a red light in the dash to warn the operator of the failure.

### DISC BRAKES FRONT—(Fig. 2)

All models have disc brakes on the front. The one piece caliper mounts on the steering knuckle/steering arm, which is also a one piece casting, and astride the brake disc. The caliper is the single piston design which is said to be a sliding caliper sliding piston. No front brake adjustment is necessary once the system is in operation and the pedal has been stroked to "seat" the shoes to the caliper.

### DRUM BRAKES REAR—(Fig. 3)

The rear brakes are duo servo (except RPO JB9) and self adjusting. Brake adjustment takes place when the brakes are applied with a firm pedal effort while the vehicle is backing up. Applying the brakes moves the actuator which turns the star wheel and lengthens the adjuster screw assembly. This action moves the shoes outward until clearance between the lining and drum is within proper limits.

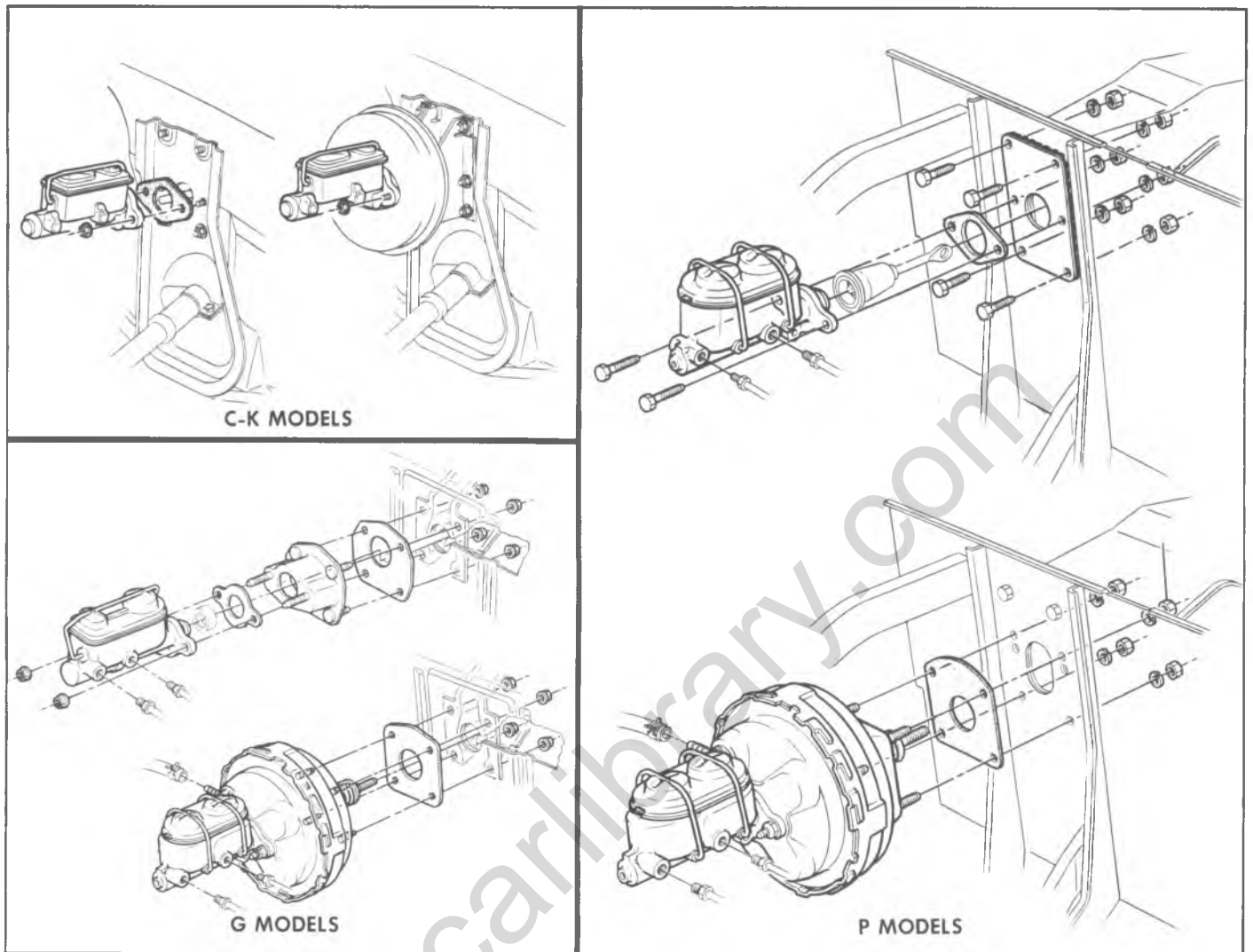

Fig. 1--Master Cylinder Mountings--Typical

## 5-4 BRAKES

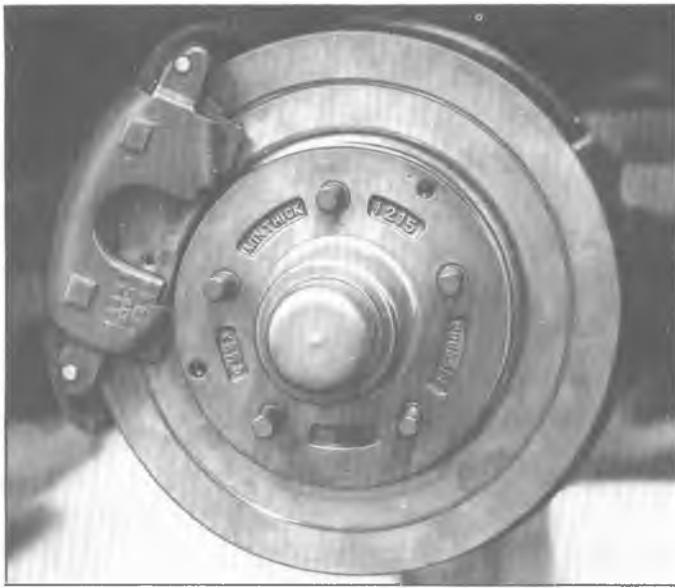

Fig. 2--Front Disc Brake (Typical)

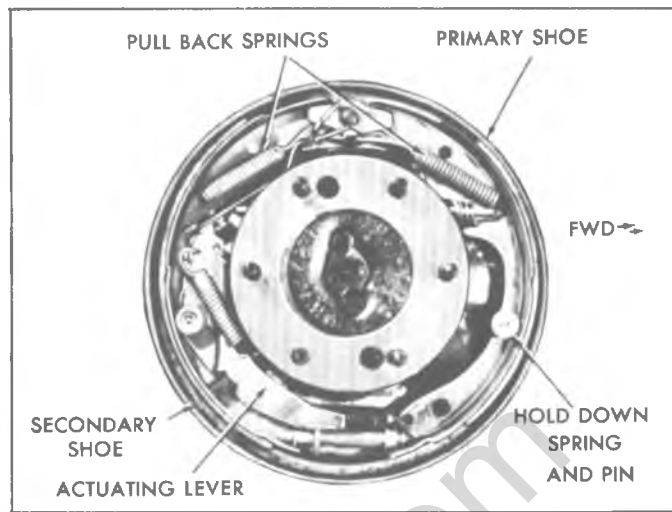

Fig. 3--Rear Drum Brake (Typical Duo-Servo)

## THEORY OF OPERATION

Brakes are simply a means of applying friction to either stop, slow down or hold an element. Brakes accomplish their job by converting motion energy, or kinetic energy, to heat energy, through brake shoes and linings.

On the present day vehicle, the brake shoes are metal with heat resistant linings attached. The brake shoes are applied against the brake drum or disc by hydraulic pressure.

To perform properly, the brake components must be properly installed and adjusted.

First, the drum or disc must be the right size and shape, diameter, width, thickness and contour to provide enough friction area and adequate heat dissipation.

Second, the linings must be of the correct material, size and contour to provide the proper amount of friction for:

- a. Proper performance
- b. Satisfactory durability
- c. Freedom from noise and scoring

Third, clearances must be correct.

Fourth, the operating system must be simple, dependable and easily adjusted.

### HYDRAULIC SYSTEM (Fig. 4)

When fluid is contained in a closed system and pressure is applied to it, the pressure is exerted equally in all directions (Pascal's Law). By applying this law, we are able to have a brake system that is easy to maintain and functionally stable.

The basic hydraulic brake system consists of (1) a master cylinder, in which the hydraulic pressure is developed, (2) a cylinder at each wheel, where hydraulic pressure is utilized to force linings to rub against a brake disc or brake drum, and (3) the necessary tubing and flexible hoses to connect the master cylinder to the wheels. Of course, we need a method of generating this hydraulic pressure so we have a pedal mounted within the vehicle and connected to the master cylinder through a push rod. The principle of hydraulic pressure is put to work through the use of the pedal.

When the pedal is depressed the master cylinder piston

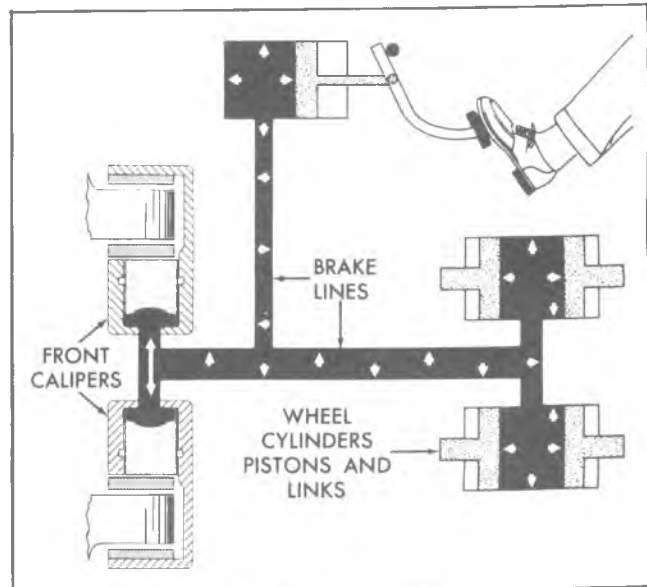

Fig. 4--Hydraulic System

is pushed forward. The fluid in the master cylinder, and the entire system, being incompressible, transmits the force exerted by the master cylinder piston to all the inner surfaces of the system. At this point only the pistons in the wheel cylinders or caliper are free to move, and since the hydraulic fluid is not compressible, the pistons move outward to force brake shoes against the brake drums or disc.

To work properly a hydraulic brake system must be leakproof, sturdy and filled with the right type of fluid. The right type of fluid is one that has no corrosive effect on the system's parts, and does not readily freeze, boil or vaporize at the temperature extremes encountered in vehicle use.

### PRESSURE AND FORCE (Fig. 5)

One of the advantages of a hydraulic system is that we have the same pressure inside the system and up to all wheels. This does not mean however that we are applying the same force at each wheel; in fact, it permits us to apply unequal force under certain circumstances.

**NOTE:** Pressure may be different at front or rear wheels due to valving. Valves are covered later in this section.

Pressure can be defined as the amount of force applied to a specific area, (measured in square inches). Suppose a hydraulic pressure of 10 psi (pounds square inch) were applied to an object with a surface area of 16 square inches. The total applied force would equal 160 pounds - (ten psi pressure times an area of 16 square inches). If the same 10 psi were applied to an object with a surface area of two square inches, a force of 20 pounds would be applied.

Reduced to a formula, this means that pressure (in pounds per square inch) times area (in square inches) equals total force applied.

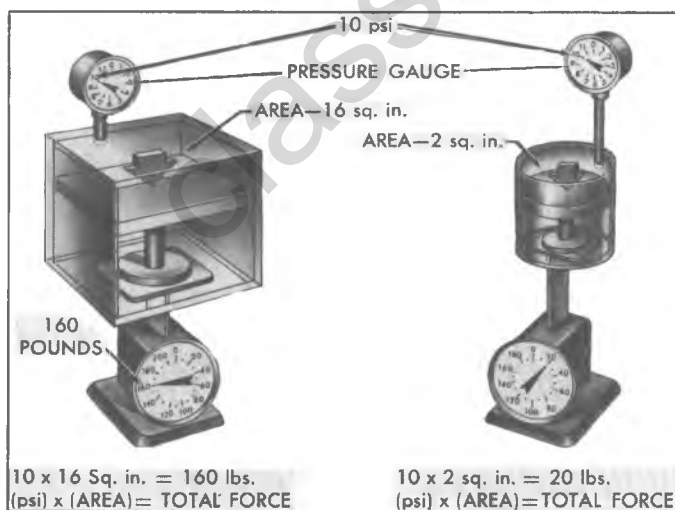

Fig. 5--Pressure and Force

This is the principle that enables us to incorporate a very desirable feature in the brake system - we can vary the braking power to the wheels by changing the wheel cylinder piston area.

Some of the vehicle weight is transferred to the front wheels when the brakes are applied. We can balance this weight transfer with different braking force at the front and rear wheels.

## BRAKE SYSTEM COMPONENTS

### MASTER CYLINDER (Fig. 6)

The master cylinders used today have split reservoirs. This means that the front and rear brakes are separated from each other by the design of the master cylinder.

The master cylinder contains two fluid reservoirs and two cylindrical pressure chambers in which force, applied to the brake pedal, is transmitted to the fluid which actuates the brake shoes. Breather ports and compensating ports permit passage of fluid between each pressure chamber and its fluid reservoir during certain operating conditions. A vented cover and flexible rubber diaphragm, at the top of the master cylinder reservoir, seal the hydraulic system from possible entrance of contamination while at the same time permitting expansion or contraction of fluid within the reservoirs without direct venting.

In the pressure chambers, coil springs hold rubber primary seals against the end of the pistons. These seals and rubber secondary seals on the opposite end of the pistons, prevent escape of fluid past the pistons. The piston is retained in the cylinder by a push rod retainer. A rubber boot is installed over this end of the cylinder to exclude foreign matter.

Stroking or pushing the brake pedal causes the primary piston in the master cylinder to move forward. At the same time, a combination of hydraulic pressure and force of the primary piston spring moves the secondary piston forward so that their primary seals cover the compensating ports, hydraulic pressure is built up and transmitted to the front and rear wheels.

When the brake pedal is released, the master cylinder pistons move rearward and hydraulic pressure on the brake system is released.

### Rear Line Failure (Fig. 7)

In case of a ruptured rear brake line or some other malfunction, the primary piston will move forward when the brakes are applied, but will not generate hydraulic pressure. Only a negligible force is transferred to the secondary piston through the primary piston spring until the primary piston comes in contact with the secondary piston. Then, push rod force is transmitted directly to the secondary piston and sufficient pressure is generated to operate the front brakes.

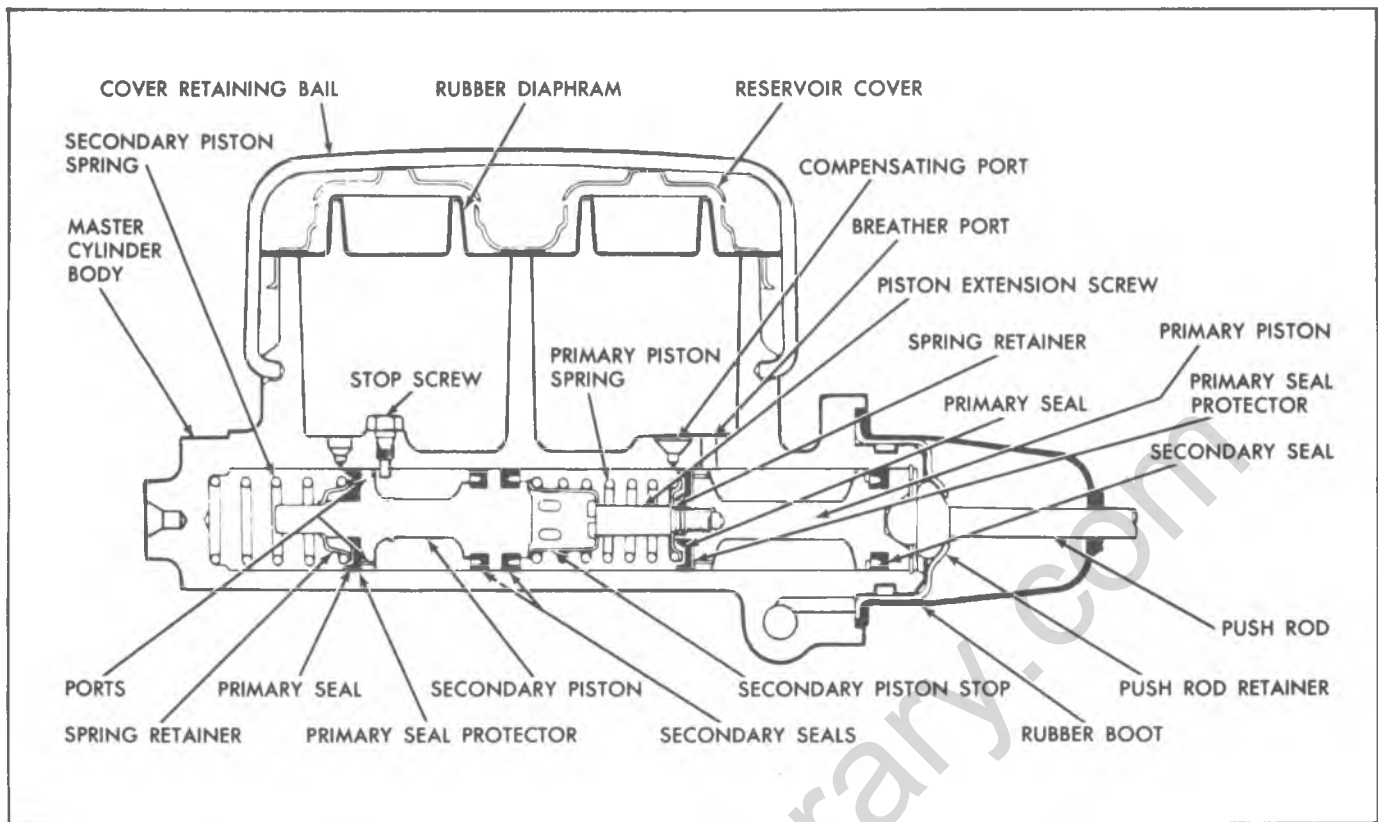

Fig. 6--Master Cylinder (Typical)

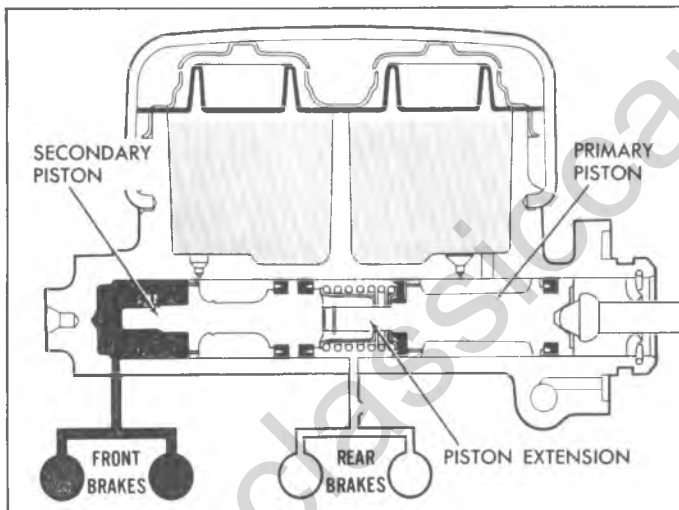

Fig. 7--Rear Line Failure (Typical)

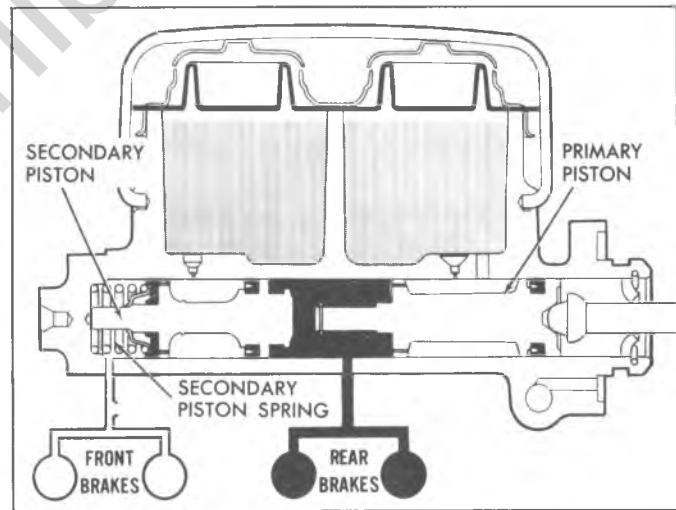

Fig. 8--Front Line Failure (Typical)

### Front Line Failure (Fig. 8)

If there is a malfunction in the front brake line, both pistons will move forward when the brakes are applied, as under normal conditions. However, due to the front line malfunction, there is nothing to resist piston travel except the secondary piston spring. This permits the primary piston to generate only negligible pressure until the secondary piston bottoms in the cylinder bore. Then,

sufficient hydraulic pressure will be generated to operate the rear brakes.

It should be noted that if either the front or rear brakes become inoperative, one brake system will remain effective and permit the vehicle to be brought to a controlled stop. Increased pedal travel will be evident as well as increased pedal force since only a part of the normally available braking surface will be used. Both of these effects should be noticeable to the driver but, as an added safety feature, a warning light has been

incorporated into the brake system. The dash-mounted warning light will come on when the brakes are applied under a condition of partial failure. This is a signal to the driver to have the brakes serviced.

### WHEEL CYLINDER (Fig. 9)

Each wheel cylinder contains two pistons and two rubber cups which are held in contact with the pistons by a central coil spring with cup expanders to provide a fluid-tight seal. The wheel cylinder cups are of a special heat resisting rubber. Cups of this material must have an expander to hold the lips of the cup out against the wheel cylinder bore. These cup expanders are crimped on each end of the wheel cylinder spring.

The inlet port for brake fluid is located between the pistons so that when fluid pressure is applied, both pistons move outward toward the ends of wheel cylinders. The pistons impart movement to the brake shoes by means of connecting links which seat in the pistons and bear against webs of the shoes. Rubber boots enclose both ends of the cylinder to exclude foreign matter. A valve for bleeding the brake lines and wheel cylinder is located above the inlet port.

### COMBINATION VALVE (Fig. 10)

The combination valve is just what its name implies. The **metering valve**, **failure warning switch** and **proportioner** are "combined" into an assembly which also serves as the front junction block. This valve is used on all disc brake applications. The input-output characteristics of the valve (i.e. split points), vary with vehicle usage.

### Metering Valve

The Metering Valve "holds-off" front disc braking until the shoes of the rear drum brake contacts the drum.

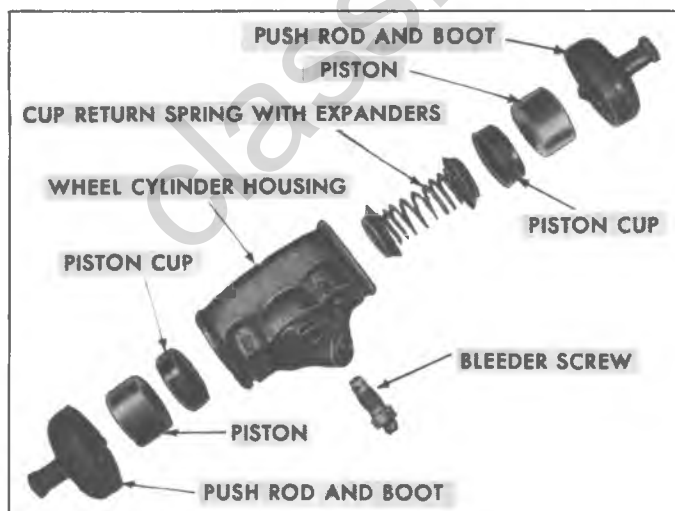

Fig. 9--Typical Wheel Cylinder

### Brakes Not Applied (Fig. 11)

The metering valve allows free flow of brake fluid through the valve when the brakes are not applied. This allows the fluid to expand and contract with temperature changes. (The boot is pressed in, to hold the pin down during bleeding operations.)

### Shut-Off Point-Initial Brake Apply (Fig. 12)

The metering valve stem moves to the left, and at 4 to 30 psi, the smooth end of the stem is in a sealing position with the metering valve seal lip and this is the shut-off point.

### Hold-Off Blend Pressure (Fig. 13)

The metering valve stem continues to the left on initial brake apply and stops on the knurl at the metal retainer. The metering valve spring holds the retainer against the seal until a predetermined psi is produced at the inlet of the valve. This pressure overcomes the spring and allows pressure through the valve to the front brakes. The continued increase of pressure into the valve is metered through the metering valve seal, through to the front brakes and produces an increasing force on the diaphragm. The diaphragm pulls the pin and the pin in turn pulls the retainer, thus reducing the spring load on the metering valve seal. Eventually, the pressure reaches the point where the spring is completely pulled away by the diaphragm pin and retainer leaving the metering valve seal free to pass unrestricted pressure through the valve.

### Failure Warning Switch (Fig. 14)

The Failure Warning Switch is activated if either front or rear brake systems fail, and when activated, completes a circuit to the dash warning lamp. If the rear hydraulic system fails, the pressure of the good front system forces the switch position to the right. The switch pin is forced up into the switch by the piston ramp and makes the electrical circuit lighting the dash lamp, and is held in this position by the piston. When repairs are made and pressure is returned to the rear system by bleeding, the piston moves to the left and resets the switch to the off position. The detent on the piston typically requires 100 to 450 psi pressure before allowing full reset (centering) of the piston. The same condition will exist if the front hydraulic system fails except the piston moves to the left.

### Proportioner

The rear brake Proportioner improves front-to-rear brake balance at high deceleration. During high deceleration stops, a percentage of the rear weight is transferred to the front wheels. Compensation must be made for the resultant loss of weight to the rear wheels to avoid early rear wheel skid. The proportioner part of the combination valve reduces the rear brake pressure and delays the rear wheel skid.

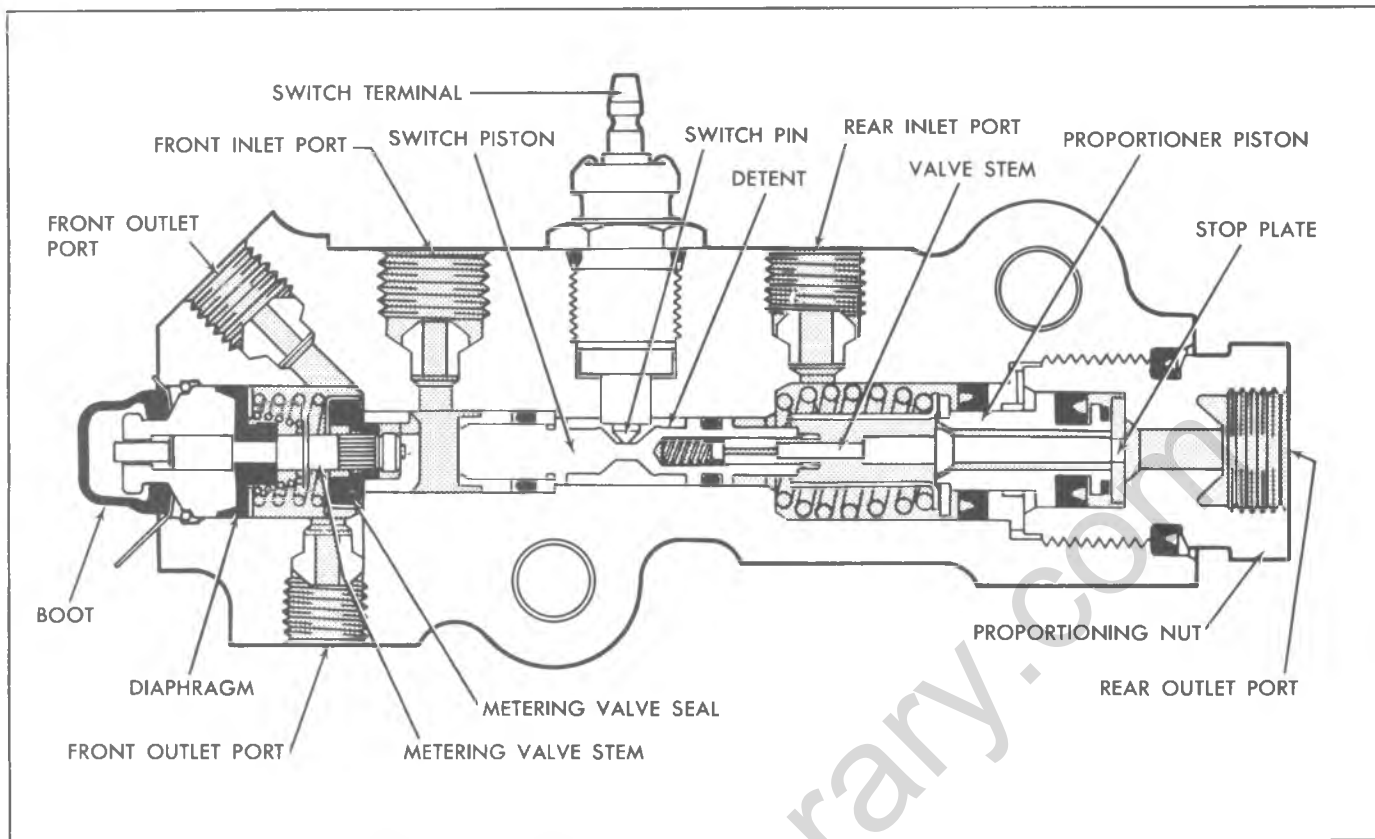

Fig. 10--Combination Valve

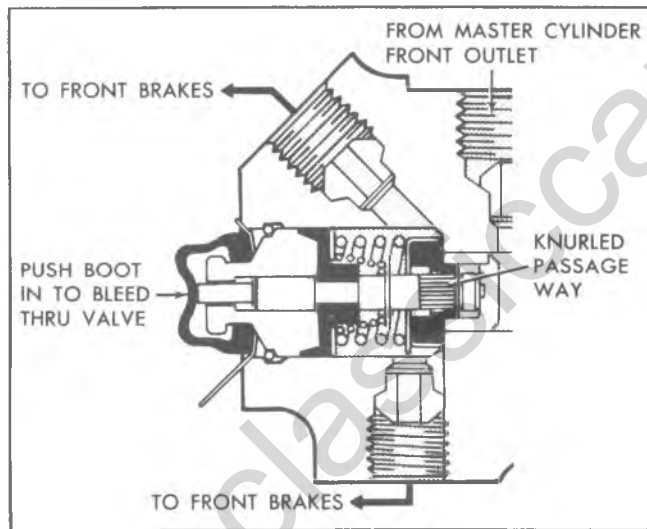

Fig. 11--Brakes Not Applied

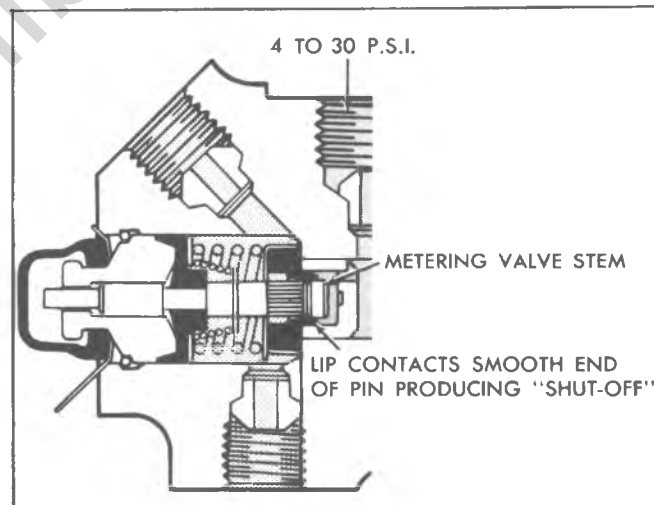

Fig. 12--Shut-Off Point

**Normal Brake Stops (Fig. 15)**

The proportioner does not operate during normal brake stops. Fluid normally flows into the proportioner, through the space between the piston center hole and valve stem, through the stop plate and out to the rear brakes. The spring loads the piston so that it rests against the stop plate for normal brake pressures.

**Proportioning Action (Fig. 16)**

Pressure developed within the valve pushes against the

large end of the piston and when sufficient to overcome the spring load, moves the piston to the left. The piston "Contacts" the spherical stem seat and starts proportioning by restricting pressure through the valve.

**Overhaul and Major Service**

The combination valve is not reparable. If a defect is found in any portion of the valve, the complete valve assembly must be replaced.



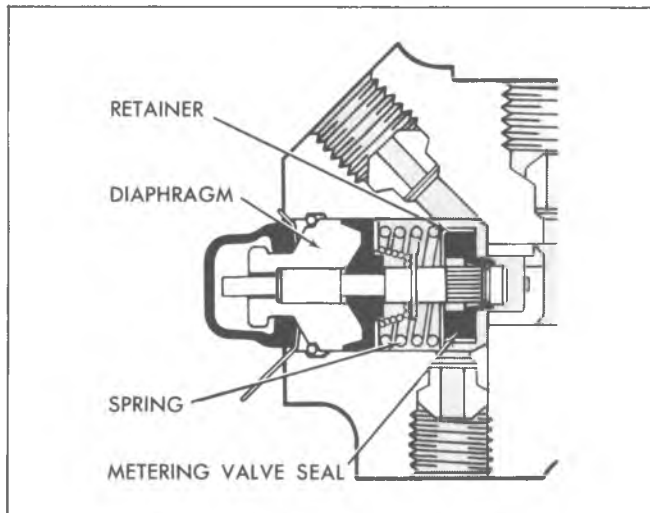

Fig. 13--Hold-Off and Blend Pressure

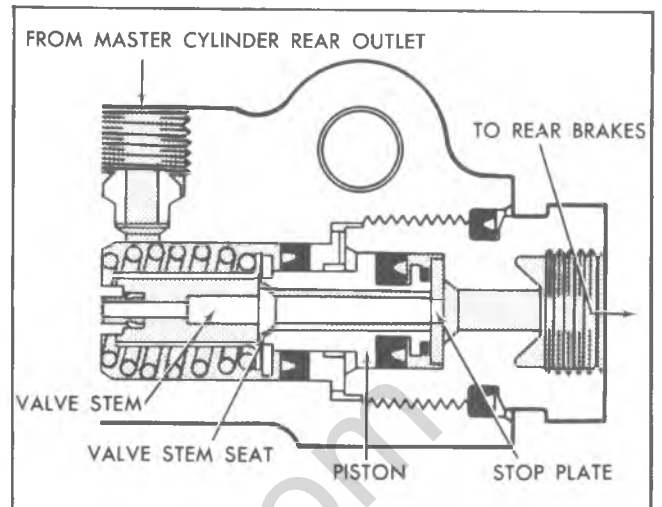

Fig. 15--Normal Brake Stop

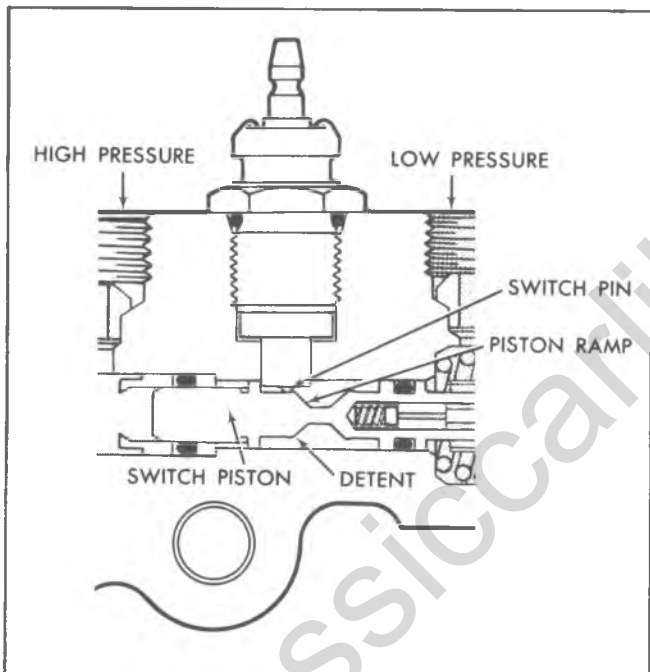

Fig. 14--Rear System Failure

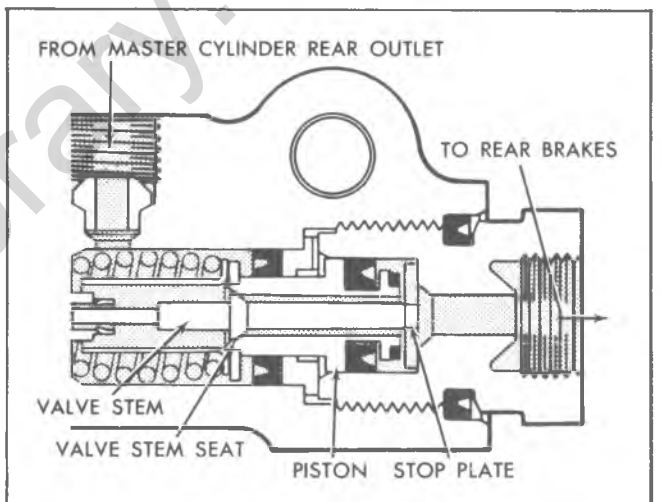

Fig. 16--Proportioning Action

## BRAKE STOPLAMP SWITCH

The brake stoplamp switch is mounted on a flange protruding from the brake pedal support bracket below the instrument panel (fig. 17). When the brake pedal is depressed, the switch plunger (which is spring loaded), follows the brake pedal arm downward until the switch is in the "ON" position. When the brake is released, the brake pedal arm returns the switch plunger to the "OFF" position.

## BRAKE PEDAL

The brake pedal is a lever, pivoted at one end, with the master cylinder push rod attached to the pedal near the pivot point. By this lever arrangement the force applied to the master cylinder piston through the push rod is

multiplied several times over the force applied at the brake pedal (fig. 18).

Proper service of the brake pedal is vital to good brake performance, and pedal operation should be checked each time brakes are inspected. Weak or broken return springs or lack of lubrication can cause sluggish release of the brakes. Wear in the pedal linkage, pivot pins, or bushings, can cause loss of pedal or frequent need for brake adjustment. Pedal free play is the free travel of the pedal before any movement of the master cylinder piston occurs. Too little free play can cause brakes to drag. Too much free play may result in a low pedal. The free play at the brake pedal pad should be 1/16 to 1/4 inch for the standard height pedal.

## OPERATION OF BRAKE MECHANISM

When the brakes are fully released, the master cylinder

## 5-10 BRAKES

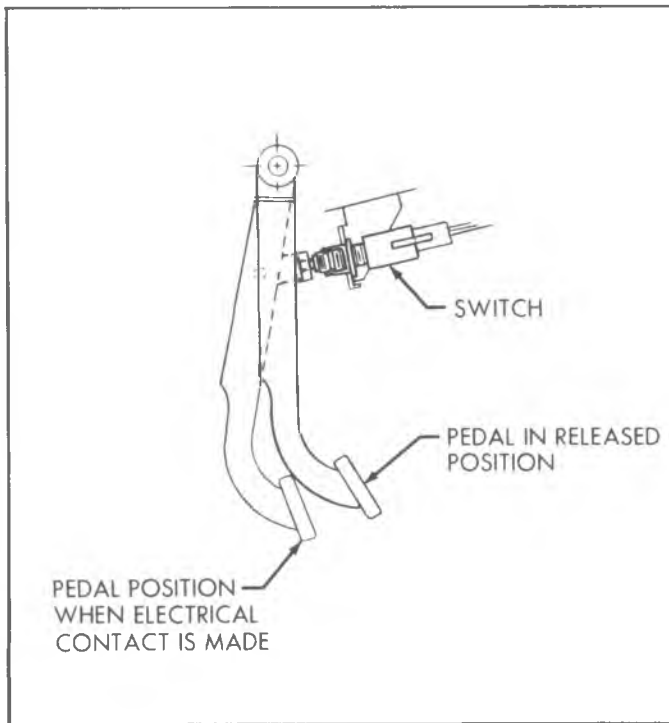

Fig. 17--Stoplamp Switch (Typical)

pistons are held against the push rod retainer, and the primary seals are held just clear of the compensating ports by the piston springs. The pressure chambers are filled with fluid at atmospheric pressure due to the open compensating ports and the flexible reservoir diaphragm.

When the brake pedal is depressed to apply the brakes, the push rod forces the master cylinder pistons and primary seals forward. As this movement starts, the lips of the primary seals cover the compensating ports to prevent escape of fluid into the reservoirs. Continued movement of the pistons builds pressure in the pressure chambers and fluid is then forced through the lines leading to the wheel cylinders. Fluid forced into the wheel cylinders between the cups and pistons causes the pistons and connecting links to move outward and force the brake shoes into contact with the drums.

Movement of all brake shoes into contact with drums is accomplished with very light pedal pressure. Since pressure is equal in all parts of the hydraulic system, effective braking pressure cannot be applied to any one drum until all of the shoes are in contact with their respective drums; therefore, the system is self-equalizing.

When the brake pedal is released, the master cylinder springs force the pedal back until the push rod contacts the retaining ring in the master cylinder. This spring also forces the pistons and primary seals to follow the push rod.

At the start of a fast release, the pistons move faster than the fluid can follow in returning from the lines and wheel cylinders; therefore, a partial vacuum is momentarily created in the pressure chamber. Fluid supplied through the breather ports is then drawn

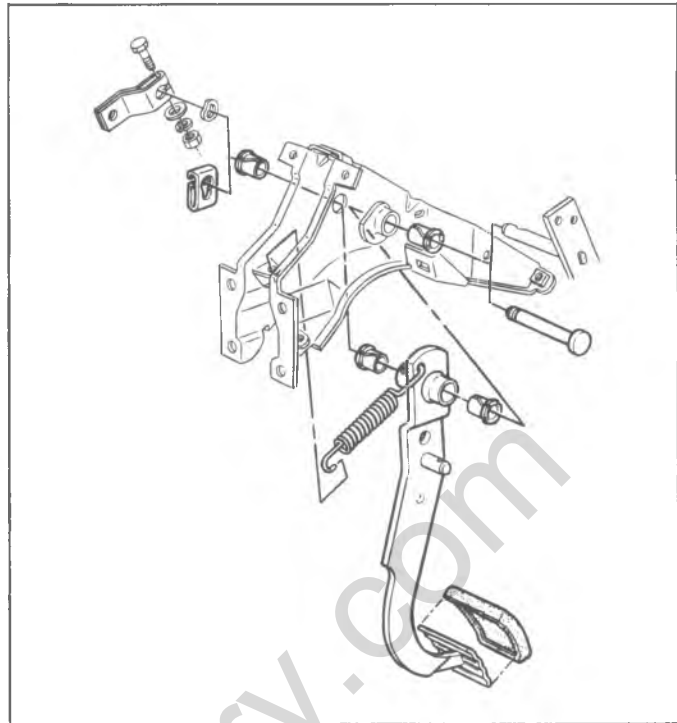

Fig. 18--Brake Pedal (Typical)

through the bleeder holes in piston heads and past the primary seals to keep the pressure chamber filled.

As pressure drops in the master cylinder, the shoe springs retract all brake shoes and the connecting links push the wheel cylinder pistons inward, forcing fluid back to the master cylinder. With the piston bearing against the retaining ring and the lips of the primary seals just clear of the compensating ports, excess fluid which entered through the bleeder holes or was created by expansion due to increased temperature, now returns to the reservoirs through the uncovered compensating ports.

### SINGLE PISTON FRONT DISC BRAKES (Fig. 19)

When fluid is contained in a closed system and pressure is applied to it, this pressure is exerted equally in all directions (fig. 4). In the single piston mechanism, hydraulic pressure acts on two surfaces.

The first, and most obvious, is the piston. The second is in the opposite direction against the bottom of the bore of the caliper housing. Since the area of the piston and bottom of the caliper bore are equal, equal forces are developed.

Hydraulic force in the caliper bore is exerted against the piston which is transmitted to the inner brake shoe and lining assembly and the inner surface of the disc. This tends to pull the caliper assembly inboard, sliding on the four rubber bushings (except Hydro-boost) or on the machined caliper mounting surface of the steering knuckle (Hydro-boost systems). The outer lining, which

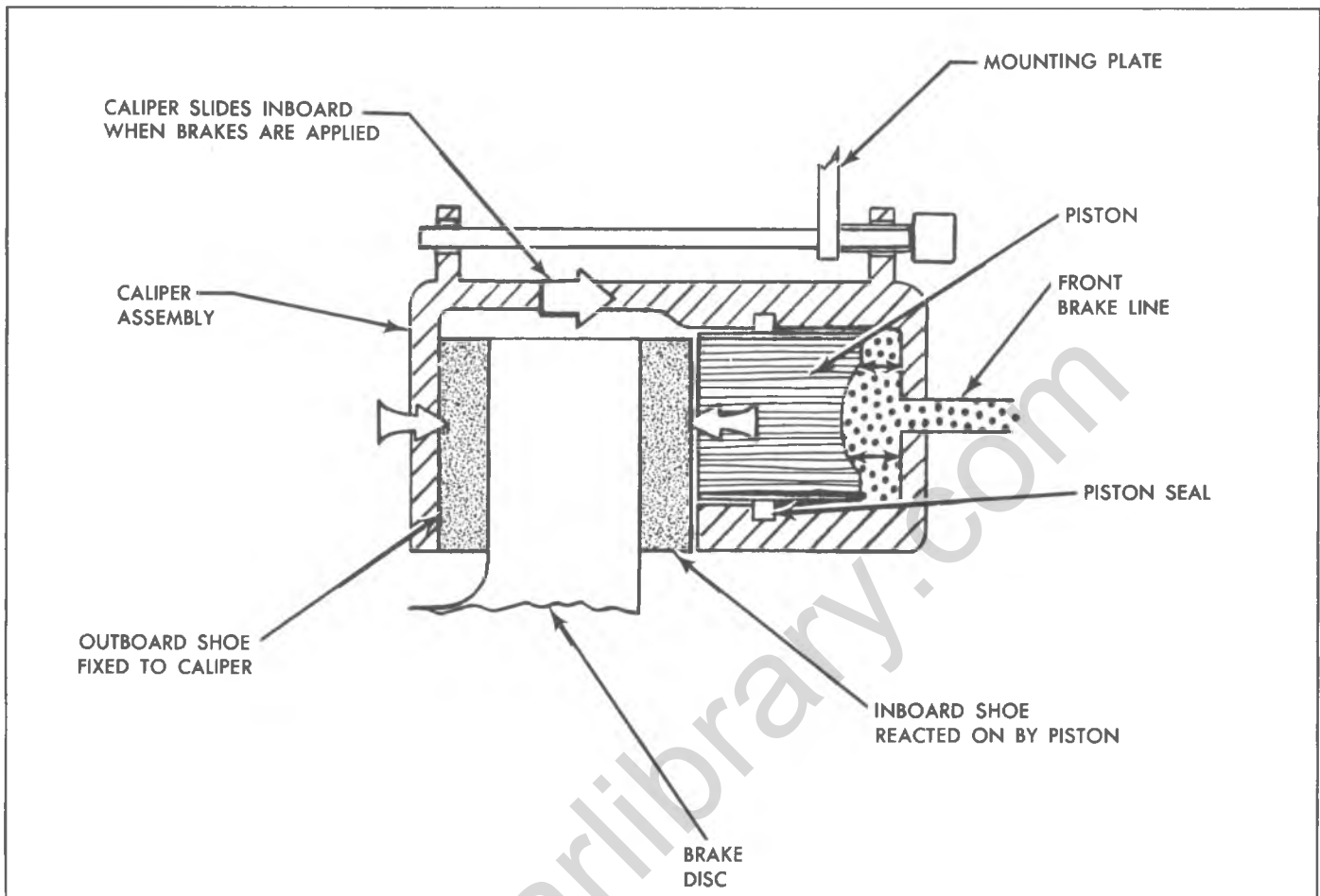

Fig. 19--Disc Brake Operation (Typical)

rests on the caliper housing, then applies a force on the outer surface of the disc and together the two linings brake the vehicle. Since an equal hydraulic force is applied both to the caliper housing and the piston, the force created against the outer surface of the disc is the same as the inner. Since there are equal forces on the linings, no flexing or distortion of the disc occurs regardless of the severity or length of application, and lining wear will tend to be equal.

Note the running clearance of the brake shoe and the brake disc in Figures 20 and 21. When the brake pedal is depressed, the piston being in contact with the other side of the brake shoe, applies force to the inner surface of the disc. This force causes the caliper to move inboard until an equal force is applied to the outer disc surface. The movement that takes place is very slight and would have to be observed very closely to be seen.

As the brake linings wear, the caliper assembly moves inboard and fluid fills the area behind the piston, so that there is not a condition of pedal travel increase with respect to the front brake as the linings wear (fig. 20).

As the driver releases the brake pedal, it is important that the piston immediately release from the shoe and lining. As pointed out earlier, the movement from no

application to full application is very slight, therefore it should be easy to understand that as force is removed, the piston and caliper merely relax into the released position and braking effort is removed.

An important thing to remember about disc brakes is that the lining is in constant contact with the disc (fig. 20) giving the added advantages of improved brake response, reduced pedal travel and faster generation of

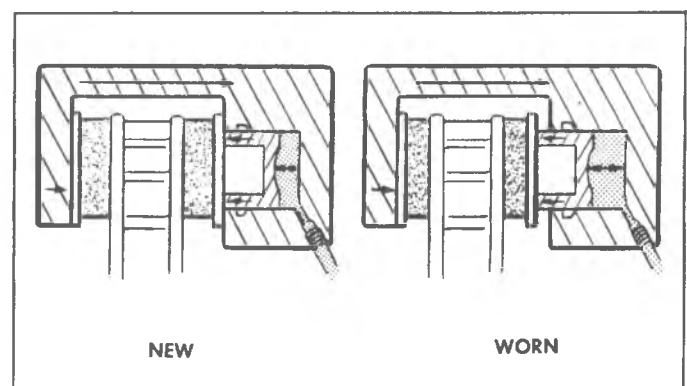

Fig. 20--New and Worn Linings

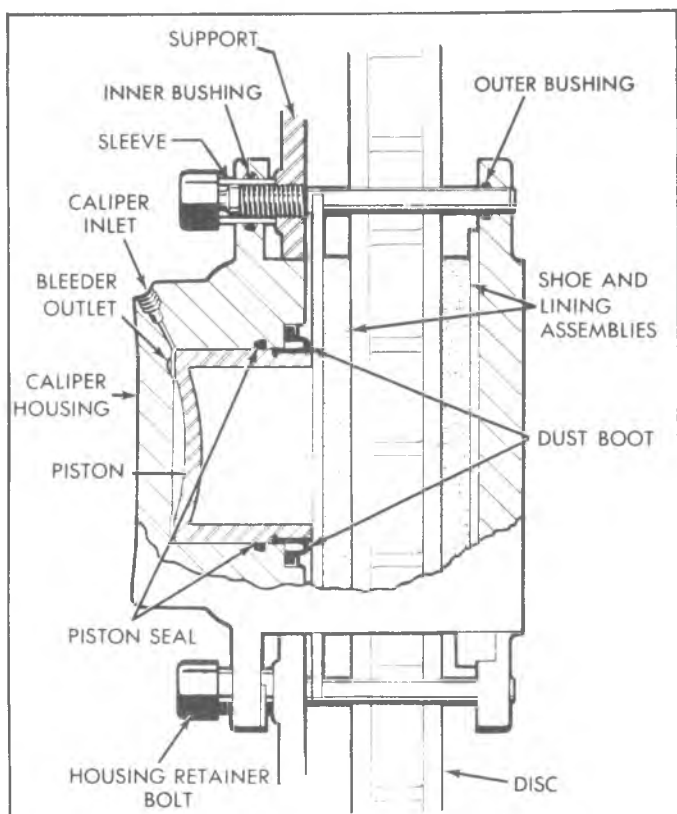

Fig. 21--Disc and Caliper - Single Piston

line pressure. The shoe, being at zero clearance, also "wipes" the disc free of any foreign matter. Disc brakes also have good fade resistance with fast recovery.

The major components of the single piston sliding caliper disc brake are the hub and disc assembly, the shield, the support, the caliper assembly, and the shoe and lining assemblies (fig. 21). The cast iron disc is of the fully ventilated design. Note that between the machined braking surfaces are cooling fins. This design acts to cool the brakes by fanning the air and in addition has many cooling surfaces.

### Hub and Disc

The purpose of the disc is to provide the frictional surfaces required to stop the vehicle.

### Shield

The disc is protected from cross vehicle splash by a shield on the inboard side that is bolted to the steering knuckle.

### Brake Caliper

The caliper provides a means of applying the shoe and lining assemblies to the disc. It is connected to the system by a hydraulic line. On non-Hydro-boost vehicles, the caliper is mounted to the support plate by two housing retainer bolts, two sleeves and four rubber bushings. An inner caliper rubber bushing is installed between each

sleeve and groove in the housing, and an outer caliper rubber bushing is installed between each bolt and groove in the housing. On Hydro-boost vehicles, the caliper is mounted between machined surfaces of the steering knuckle and held in place by a spring and support key. Shoe and lining assemblies are positioned on the caliper so they straddle the disc.

## REAR DRUM BRAKES (Fig. 22)

### DUO-SERVO

The entire rear wheel brake mechanism is mounted on the brake flange plate, which is bolted directly to the axle housing (fig. 22).

The anchor pin is the upper pivot point of the brake shoes. It is located above the wheel cylinder, and is secured to the top of the flange plate.

Two brake shoes are used, a primary shoe toward the front of the vehicle, and a secondary shoe toward the rear. Brake shoe linings are secured to the shoes. The primary shoe lining is shorter than the secondary shoe lining.

The shoes are fitted to the anchor pin at the top and secured by color-coded retracting springs. At the bottom they fit into grooves at each end of the adjuster assembly and are retained in position by a primary to secondary connecting spring located above the adjuster assembly. Each shoe is also attached to the flange plate by means of a hold-down pin, which is retained in position by a hold-down spring and retainer cup.

The adjuster assembly is installed under the primary to secondary shoe connecting spring. A self-adjusting brake shoe mechanism consisting of a link, actuating lever, pawl and pawl return spring is also used. The loop end of the link is attached to the shoe guide plate and the hooked end to the actuating lever.

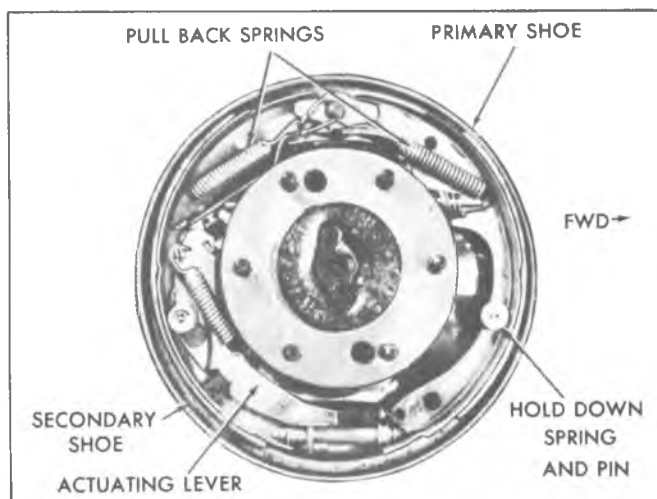

Fig. 22--Rear Drum Brake - Right Side Shown

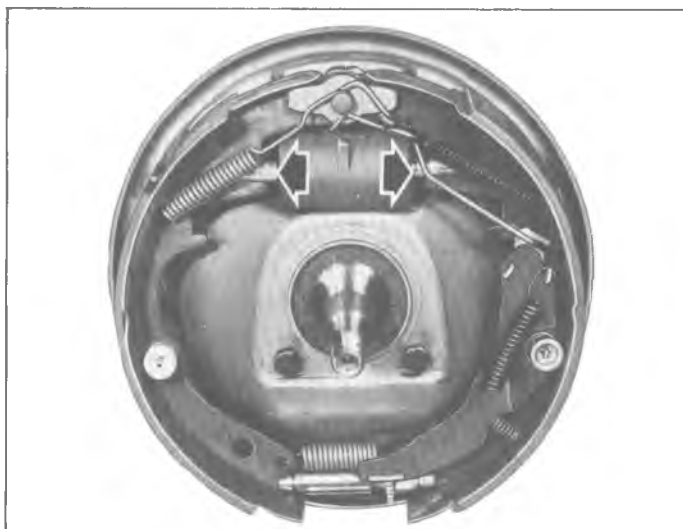

Fig. 23--Brake Operation

### Self Energizing Action (Fig. 23)

The brakes are self-energizing. This means that the brake unit is designed to assist the driver in forcing the shoes against the drum. To see how this is done, let's observe a step-by-step sequence of brake action.

When pressure is applied to the brake pedal, fluid is delivered under pressure from the master cylinder to each of the wheel cylinders. At each wheel cylinder the fluid forces the two pistons outward in the bore. This motion is transmitted from the piston to the shoes by thrust rods or "struts".

This action forces the shoes outward at the top causing the shoes to pivot on the adjusting screw assembly (as the shoes move outward, they also stretch the pull-back springs which are used later to return the shoes to the rest position).

When the shoes expand outward, they contact the drum and tend to rotate with the drum. It is this principle that allows the self-energizing feature to exist. The primary shoe (the first shoe from the anchor pin in the direction of normal rotation), rotating with the drum, moves away from the anchor pin and exerts a rearward force on the adjusting screw.

At the same time this is taking place the secondary shoe is rotating upward until the shoe web contacts the anchor pin.

We can then see that the force applied to the secondary shoe is the sum of the apply force on the primary shoe and the force caused by rotation (friction force) of the primary shoe. This combination of force is the self-energizing feature, and the increased force it applies to the brake shoes results in less physical effort required at the brake pedal.

The increased braking force applied to the secondary shoe accounts for the fact that the secondary shoe lining area is usually larger than that of the primary shoe lining.

When the brakes are applied with the vehicle moving in reverse, the rear shoe becomes, in effect, the primary shoe. The self-energizing action now would be applied to the front shoe, and the rear shoe would move away from the anchor pin.

### Self-Adjusting Action

With the understanding of the operation of the drum brake system, we can apply the same step-by-step sequence to see how the self-adjusting mechanism operates. In the component description given earlier, we found that the actuating lever assembly of the self-adjusting mechanism is mounted on the secondary or rear shoe.

The lever is attached to the web of the secondary shoe by the hold down pin and spring. The deep dished washer, used as the hold down spring seat, passes through the lever and into the shoe web. Thus, the lever is allowed to pivot about this point. Also, this spring type mount keeps the pawl end of the lever in firm contact with the teeth of the adjusting screw star wheel.

### Forward Stops (Fig. 24)

During a forward stop, the shoes expand outward and contact the drum; they rotate with the drum until the secondary or rear shoe contacts the anchor pin. Thus the pivot point for the secondary shoe moves only far enough to place the lining in contact with the drum. Subsequent motion is then in the direction of the anchor pin. When the brakes are released, the secondary shoe is already in contact with the anchor pin, so its only movement is to pivot on the anchor pin, and follow the primary shoe to the rest position. Now, let's see what affect the forward stop has on the self-adjusting mechanism. First, the small amount of movement from the rest position until the shoes contact the drum, is permitted without activating the adjusting mechanism by the slack inherent to this linkage design. Since the

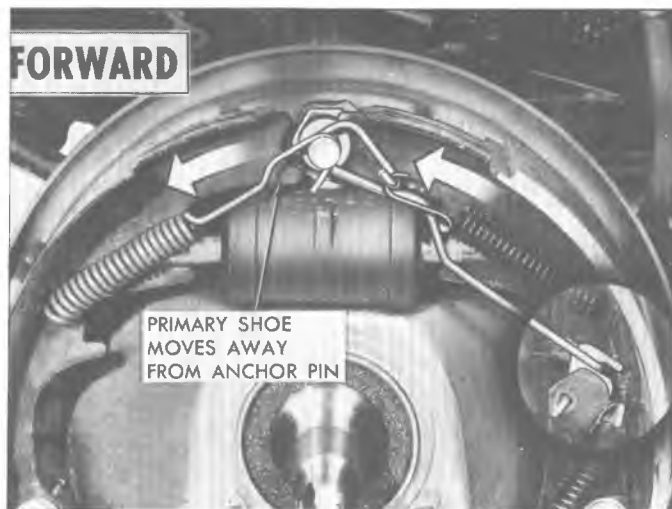

Fig. 24--Reaction During Forward Stop

## 5-14 BRAKES

rotation of the secondary or rear shoe is toward the anchor pin, the effective distance from the pin to the actuating lever is not increased; thus, no adjustment occurs. When the brakes are released, the linkage relaxes with any small degree of motion absorbed by the linkage slack.

### Reverse Stops (Fig. 25)

During a reverse stop, the shoes expand outward to contact the drum, and then rotate with the drum until the primary or front shoe contacts the anchor pin. When there is sufficient clearance between the lining and the drum, this rotation increases the distance from the anchor pin to the secondary or rear shoe hold down pin. Since the wire link between the anchor pin and actuating lever is a fixed length, the movement of the lever pivot point causes the top of the actuating lever to be pulled inward. As the lever pivots on the hold down spring cup, the pawl end rocks down on the adjusting screw star wheel. When the pawl turns the star wheel, it increases the length of the adjusting screw in much the same manner as a service technician using a brake adjusting tool.

As the lever rocks down to turn the star wheel, it also moves outboard to follow the contour of the star wheel. At the same time, the downward motion compresses the lever return spring. When the brakes are released, the pull-back springs return the shoes to their normal position, the lever return spring raises the pawl end of the lever back to its normal position. The pawl slips back over the teeth of the star wheel and takes a new "bite" on another notch.

When there is only a slight clearance between the shoes and drums, such as the condition when the brakes are near to proper adjustment, the shoes rotate only a small amount before the shoes contact the anchor pin. This slight amount of movement is not enough to cause the actuating lever to advance the star wheel.



Fig. 25--Reaction During Reverse Stop

### Over-Ride Mechanism (Fig. 26)

All of the standard equipment self-adjusting mechanisms contain a built-in safety device known as the "over-ride pivot plate and spring". This pivot plate and spring are mounted on the upper end of the actuating lever, acting as a semi-rigid connection between the actuating lever and the wire link. The over-ride mechanism has one major function; to prevent damage to the linkage when, for some reason, the linkage cannot move as dictated by shoe rotation. Two common examples of this condition occurs when; the adjusting screw binds, or the brakes are severely out of adjustment.

If the adjusting screw threads should bind, the self-adjusting mechanism would attempt to continue operating. This would result in damaged parts, or possible reduced brake application on the affected wheel. When this occurs, the actuating lever remains stationary, and the over-ride pivot plate is pulled by the wire link. This motion is absorbed by stretching the over-ride spring. With the adjusting motion dampened by the spring, the component parts remain undamaged.

**NOTE:** One symptom of a bound adjusting screw is "pulling brakes". Inspect the screw when a complaint of brake pull is reported.

The second purpose of the over-ride plate is to prevent excessive actuating lever travel. This condition could occur if the brake adjustment were extremely loose. Should this condition occur, the motion of the actuating lever could allow the pawl end to rock down until it contacted the secondary shoe. Here again, without the over-ride spring, linkage damage or reduced brake efficiency could result.

Equally important to proper brake adjustment is the prevention of adjusting screw "back-off". The self-energizing force transmitted by the adjusting screw tends to compress the screw length. We can thus see the necessity of preventing star wheel "back-off" during the maximum self-energizing condition. To do this, a "stop

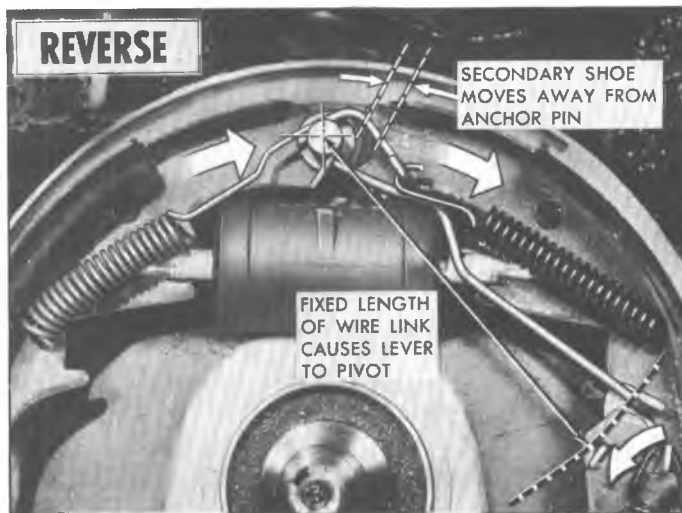

Fig. 26--Override Component Operation

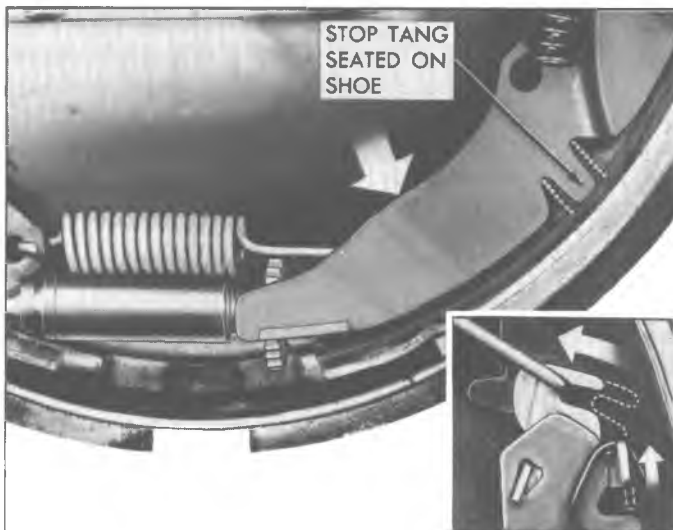

Fig. 27--Actuating Lever Stop Tang

tang" extends down from the under side of the actuating lever to contact the secondary shoe (fig. 27). This limits the actuating lever travel to a maximum of three notches per stroke, which has the effect of maintaining pawl engagement to the star wheel while braking to a stop.

Again, as in the case of a bound adjusting screw, any additional shoe motion is absorbed by the over-ride pivot plate and spring.

**NOTE:** The actuating lever stop is also the mount and guide for the lever return spring.

The actuating lever is held against the secondary shoe by the hold-down spring and cups. The pawl is connected to the actuating lever and held in position by the pawl return spring.

## H-22 (RPO JB9) BRAKES

These brakes are mounted on an assembly consisting of two brackets and a flange plate which bolts to the axle housing.

The brackets take the reaction forces from the shoes and provide a position for the self adjuster screw.

Two brake shoes are used but they are independent of one another--there is essentially two complete, separate brake systems within this brake. Since the two brake systems are separate, the shoes are identical.

The shoes locate on a pad on one bracket and on the head of the adjuster screw. They are connected together by two retractor springs attached at the top of the hold-down pins. Each shoe is located to the flange plate with two hold-down pins, springs, retainers and clips.

## MAINTENANCE AND ADJUSTMENTS

### BRAKE INSPECTION

Every 12 months or 12,000 miles--whichever occurs first:

The adjuster assembly is similar to that used on the duo-servo brake described previously.

### Self Energizing Action

The brakes are self-energizing. This means that the brake unit is designed to assist the driver in forcing the shoes against the drum. To see how this is done, let's observe a step-by-step sequence of brake action.

When pressure is applied to the brake pedal, fluid is delivered under pressure from the master cylinder to each of the wheel cylinders. At each wheel cylinder the fluid forces the two pistons outward in the bore. This motion is transmitted from the piston to the shoes by thrust rods or "struts".

The shoes expand outward, contact the drum and tend to rotate with it (as the shoes move outward, they also stretch the pull back springs which are used later to return the shoes to the rest position). It is this principle that allows the self energizing feature to exist. The location of the pad on the anchor bracket is such that a portion of the force applied to it by the shoe pushes outward on the shoe causing greater drag between the shoe and drum.

### Self-Adjusting Action

The self-adjusting operation principles of this brake are almost identical to those of the duo-servo brake. The major differences are:

1. There are two separate systems, attached as though each shoe were a secondary shoe.
2. With this system, a separate pin and spring holds the adjuster to the shoe instead of using the shoe hold-down pin for both.

### Parking Brake Activating Mechanism

The activating mechanism for the parking brake consists of an operating lever located in back of the secondary shoe, and attached to the shoe by a pivot at the upper end. A strut rod located a few inches below the pivot point, extends forward from this lever to the primary shoe.

The parking brake cable is connected to the lower end of the operating lever. When the parking brake is applied, the cable pulls the lower end of the operating lever forward, causing the strut rod to push the primary shoe forward. At the same time, the upper end of the lever pushes the secondary shoe rearward. The combined action of the lever and the strut rod drives the primary and secondary shoes apart and into contact with the drums.

Inspect drum brake linings or disc brake pads, as well as the other internal brake components at each wheel

## 5-16 BRAKES

(drums, rotors, wheel cylinders, etc.). For convenience, it is recommended that disc brake pads be checked whenever tires are rotated (at 6000 mile intervals). More frequent checks should be made if driving conditions and habits result in frequent brake application. Parking brake adjustment should also be checked whenever brake linings are checked.

**NOTE:** During any inspection period, the remaining lining life expectancy should be determined. This determination should dictate the next inspection period.

### Lining Inspection

#### Drum Brake

Replace whenever the thickness of any part of any lining is worn to within 1/32" of the shoe table or rivet head whichever is applicable.

Another important point to remember, always replace brake shoes in axle sets (right and left side).

#### Disc Brakes

Check both ends of the outboard shoe by looking in at each end of the caliper. These are the points at which the highest rate of wear normally occurs. However, at the same time, check the lining thickness on the inboard shoe to make sure that it has not worn prematurely.

Replace whenever the thickness of any part of any lining is worn to within 1/32" of the shoe or rivet whichever is applicable.

### HYDRAULIC BRAKE FLUID

Brake fluid is a specially blended liquid which provides a means of transmitting hydraulic pressure between the master cylinder and the brake calipers and wheel cylinders. Brake fluid is one of the most important parts of the hydraulic system. Use GM Hydraulic Brake Fluid Supreme No. 11, meeting GM Specification GM4653M (or DOT-3 brake fluids).

Brake fluid must have certain specific qualities such as:

1. Viscosity (free flowing at all temperatures).
2. High boiling point (remain liquid at highest operating temperatures).
3. Non-corrosive (must not attack metal or rubber parts).
4. Water tolerance (must be able to absorb and retain moisture).
5. Lubricating ability (must lubricate piston and seals to reduce wear and internal friction).
6. Low freezing point (must not freeze even at lowest operating temperatures).

If brake fluid becomes contaminated, it may lose some of its original qualities. It is good practice to bleed the brake system until all old fluid is removed when performing major brake work. Old fluid should be bled from the system and replaced with clean brake fluid if any of the hydraulic system parts are corroded or the fluid is discolored or dirty. If any of the rubber parts of the hydraulic system are soft or swollen old fluid should be removed and hydraulic system should be flushed with clean brake fluid. **Do not** reuse old brake fluid at any time.

In the event that improper fluid has entered the system, it will be necessary to service the system as follows:

1. Drain the entire system.
2. Thoroughly flush the system with clean brake fluid.  
**CAUTION:** Use only brake fluid when flushing a system.
3. **Replace all rubber parts of the system, brake hoses and combination valve.**
4. Refill the system.
5. Bleed the system.

### Flushing Brake Hydraulic System

It is recommended that the entire hydraulic system be thoroughly flushed with clean brake fluid whenever new parts are installed in the hydraulic system.

Flushing is also recommended if there is any doubt as to the grade of fluid in the system or if fluid has been used which contains the slightest trace of mineral oil.

Flushing is performed at each bleeder valve in turn, and in the same manner as the bleeding operation except that bleeder valve is opened 1-1/2 turns and the fluid is forced through the lines and bleeder valves until it emerges clear in color. Approximately one quart of fluid is required to flush the hydraulic system thoroughly.

When flushing is completed at all bleeder valves, make certain the master cylinder reservoir is filled to proper level.

### BLEEDING HYDRAULIC SYSTEM

The hydraulic brake system must be bled whenever, any line has been disconnected or air has in some way entered the system. Bleeding of brake system may be performed by one of two methods -- either pressure or manual. Bleeder valves are provided at the calipers and wheel cylinders.

#### Sequence for Bleeding

It is advisable to bleed one valve at a time to avoid allowing fluid level in reservoir to become dangerously low. The correct sequence of bleeding is to bleed the valve, either front or rear system, nearest master cylinder first. This sequence expels air from lines and calipers or wheel cylinders nearest the master cylinder first and eliminates the possibility that air in a line close to the



master cylinder may enter a line farther away after it has been bled.

**CAUTION:** Do not perform bleeding operation while any brake drum is removed or with a caliper removed from the disc.

### Pressure Bleeding (Figs. 28 and 29)

**NOTE:** Pressure bleeding equipment must be of the diaphragm type. That is, it must have a rubber diaphragm between the air supply and the brake fluid to prevent air, moisture, oil and other contaminants from entering the hydraulic system.

1. Clean all dirt from top of master cylinder and remove cylinder cover and rubber diaphragm.

**NOTE:** Make sure brake fluid in bleeder equipment is at operating level and that the equipment is capable of exerting 20 to 30 lbs. hydraulic pressure on the brake system.

2. Install Brake Bleeder Adapter J-23518 on master cylinder. Connect hose from bleeder equipment to bleeder adapter and open release valve on bleeder equipment.

**NOTE:** The combination valve, located near the master cylinder, must be held in the open position while bleeding. This can be accomplished by installing Tool J-23709 with the open slot under the mounting bolt and pushing in on the pin in the end of the valve (fig. 28). Be sure to retorque the mounting bolt after removing Tool J-23709.

3. Install Brake Bleeder Wrench J-21472 on caliper bleeder valve nearest the master cylinder and install one end of bleeder hose on bleeder valve.

**NOTE:** Bleed the valve nearest the master cylinder first, then the next nearest and so on

until all valves have been bled and there is no evidence of air in the system.

4. Pour a sufficient amount of brake fluid into a transparent container to ensure that end of bleeder hose will remain submerged during bleeding. Place the loose end of bleeder hose into the container. Be sure the hose end is submerged in the fluid (fig. 29).
5. Open bleeder valve by turning Tool J-21472 counterclockwise approximately 3/4 of a turn and observe flow of fluid at end of bleeder hose.

**NOTE:** To assist the bleeding operation a rawhide mallet may be used to tap the caliper while fluid is flowing.

6. Close bleeder valve tight as soon as bubbles stop and brake fluid flows in a solid stream from the bleeder hose.

**CAUTION:** See "Caution" on Page 1 of this section.

7. Remove brake bleeder wrench and bleeder hose from bleeder valve.
8. Repeat Steps 3 through 7 on the remaining bleeder valves.
9. Disconnect bleeder equipment from brake bleeder adapter.

**NOTE:** The master cylinder on certain models is tilted. When removing the bleeder adapter on these models, place a clean dry cloth below the cylinder to absorb any fluid spillage as the cover is removed.

10. Remove bleeder adapter. Wipe all areas dry if fluid was spilled during adapter removal.
11. Fill master cylinder reservoirs to within 1/4" of reservoir rims as shown in Figure 30.
12. Install master cylinder diaphragm and cover.

**CAUTION:** When installing the master cylinder

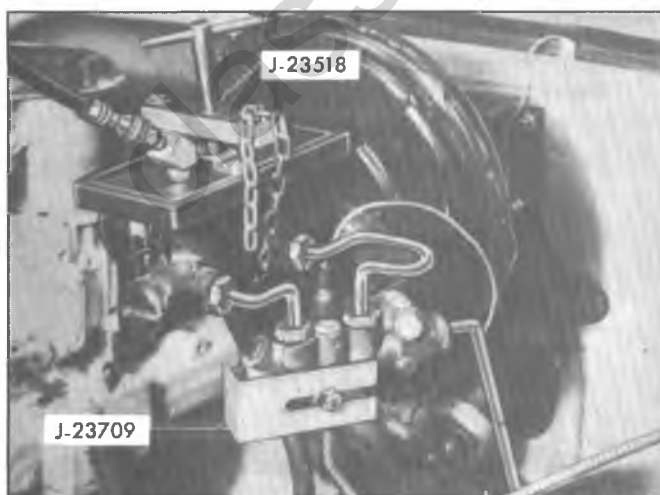

Fig. 28--Brake Bleeder J-23518 and J-23709 (Typical)



Fig. 29--Bleeding Brakes with Tool J-21472

## 5-18 BRAKES

cover, the retaining bail should be slipped over the lower cover bosses (fig. 31). Incorrect installation could result in bail tension loss and fluid leakage.

13. Test operation of brake pedal before moving the vehicle.

### Manual Bleeding

1. Clean all dirt from the top of the master cylinder and remove the cylinder cover and rubber diaphragm.
2. Fill master cylinder (if necessary) and reinstall the cover.
3. Install Brake Bleeder Wrench J-21472 on caliper bleeder valve nearest the master cylinder and install a bleeder hose on the bleeder valve (fig. 29).

NOTE: The combination valve, located near the master cylinder, must be held in the open

position while bleeding. This can be accomplished by installing Tool J-23709 with the open slot under the mounting bolt and pushing in on the pin in the end of the valve (fig. 28). Be sure to retorque the mounting bolt after removing Tool J-23709.

Bleed the valve nearest the master cylinder first, then the next nearest and so on until all valves have been bled and there is no evidence of air.

**CAUTION:** See "Caution" on Page 1 of this section.

4. Pour a sufficient amount of brake fluid into a transparent container to ensure that the end of the bleeder hose will remain submerged during bleeding. Place the loose end of the bleeder hose into the container.

NOTE: Carefully monitor the fluid level at the master cylinder during bleeding. Do not bleed enough fluid at one time to drain the reservoir. Replenish as needed to ensure a sufficient amount of fluid is in the master cylinder at all times.

5. Open bleeder valve by turning Tool J-21472 counterclockwise approximately  $3/4$  of a turn. Have helper depress the brake pedal. Just before the brake pedal reaches the end of its travel, close the bleeder valve tightly and allow the brake pedal to return slowly to the released position. Repeat Step 5 until expelled brake fluid flows in a solid stream without the presence of air bubbles, then close the bleeder valve tightly.

NOTE: To assist the bleeding operation a rawhide mallet may be used to tap the caliper while fluid is flowing.

**CAUTION:** See "Caution" on Page 1 of this section.

6. Remove brake bleeder wrench and hose from the bleeder valve and repeat Steps 2 through 6 on the remaining bleeder valves.
7. Fill the master cylinder to the level shown in Figure 30.
8. Install the master cylinder diaphragm and cover.

**CAUTION:** When installing the master cylinder cover, the retaining bail should be slipped over the lower cover bosses (fig. 31). Incorrect installation could result in bail tension loss and fluid leakage.

NOTE: In order to have a good surge of fluid at the bleeder valve, the brake pedal should be pumped up and pressure held before each opening of the valve.

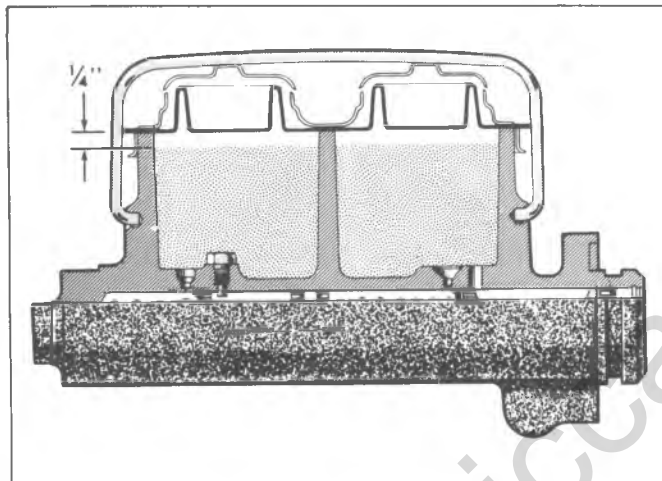

Fig. 30--Correct Fluid Level

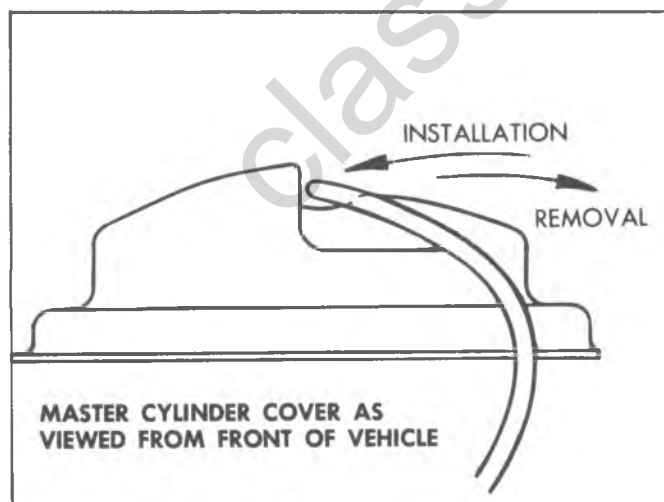

Fig. 31--Master Cylinder Cover Installation

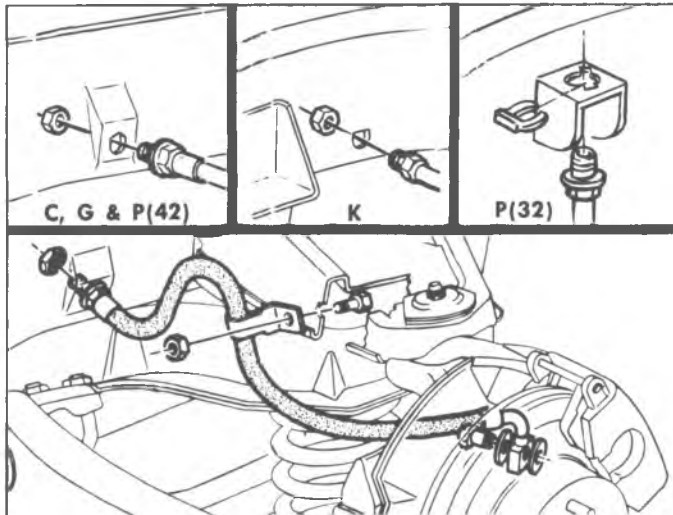

Fig. 32--Brake Hose Frame Support--Typical

## HYDRAULIC BRAKE LINES AND TUBING (Figs. 32 and 33)

### Hydraulic Brake Hose

The flexible hoses which carry the hydraulic pressure from the steel lines to the brake calipers are carefully designed and constructed to withstand all conditions of stress and twist which they encounter during normal vehicle usage.

These hoses require no service other than periodic inspection for damage from road hazards or other like sources. Should damage occur and replacement become necessary, the following procedure should be followed.

#### Removal

1. Clean all dirt and foreign material away from both hose fitting ends.
2. Separate steel line from flex hose. Use a back up wrench on the hose fitting.
3. Remove clip retainer from frame attachment.
4. Remove hose to caliper bolt and remove hose.

#### Installation (Fig. 32)

1. Install the hose to the caliper using new gaskets. Torque the mounting bolt.

**CAUTION:** See Caution on Page 1 of this section.

*Hose line must be installed in caliper locating gate (except "K" models); connector arm in caliper locating gate ("K" series).*

2. Insert hose into frame bracket or frame. This end of hose will properly mate to the bracket or frame in one direction only.
3. Install the clip retainer.
4. Install the steel line to the flex line using a back up wrench on the hose fitting. Inspect to ensure that

hose replacement has not caused the support bracket to loosen; retorque bracket attachment if required.

**CAUTION:** See Caution on Page 1 of this section.

5. Bleed brakes as outlined in this section.

### Hydraulic Brake Tubing (Figs. 34 thru 38)

Hydraulic brake tubing used on all trucks is a double wall steel tubing which resists corrosion and has the physical strength to stand up under the pressures which are developed when applying the brakes. In making up hydraulic brake lines, it is important that the ends of the tubing be flared properly for the compression couplings.

**CAUTION:** When necessary to replace brake tubing, always use double wall steel tubing which is designed to withstand high pressure and resist corrosion. Steel tubing must be equivalent to GM Specification GM123M, be annealed dead soft and super terne coated. **ORDINARY COPPER TUBING IS NOT SATISFACTORY AND SHOULD NOT BE USED.**

*When replacing brake lines, be sure to install new spring steel shielding material over the replacement line in the same areas as on the line removed.*

Safety steel tubing must be double-lap flared at the ends in order to produce a strong leak-proof joint.

Brake Tube Flaring Tool J-2185-45° is used to form the double lap flare. It must be equipped with the proper size die block and upset flare punch for each size tubing to form the double-lap flare (fig. 34).

The proper size die blocks and upset flare punches are as follows:

Tubing Size	Die Block	Upset Flare Punch	Finish Flare Punch
3/16"	J-2185-27	J-2185-3	J-2185-26
1/4"	J-2185-28	J-2185-37	J-2185-26
5/16"	J-2185-29	J-2185-4	J-2185-26

Figure 35 shows two pieces of tubing, one with single-lap flare "A" and the other with double-lap flare "B". It will be noted that the single-lap flare in "A" split the tubing while the one shown in "B" is well-formed and unbroken due to the reinforcement of the double wall.

The following procedure should be followed in making up hydraulic brake lines.

### Double Lap Flaring

1. Cut the tubing to the desired length, using Tool J-8000. Square off ends of tube and ream sharp

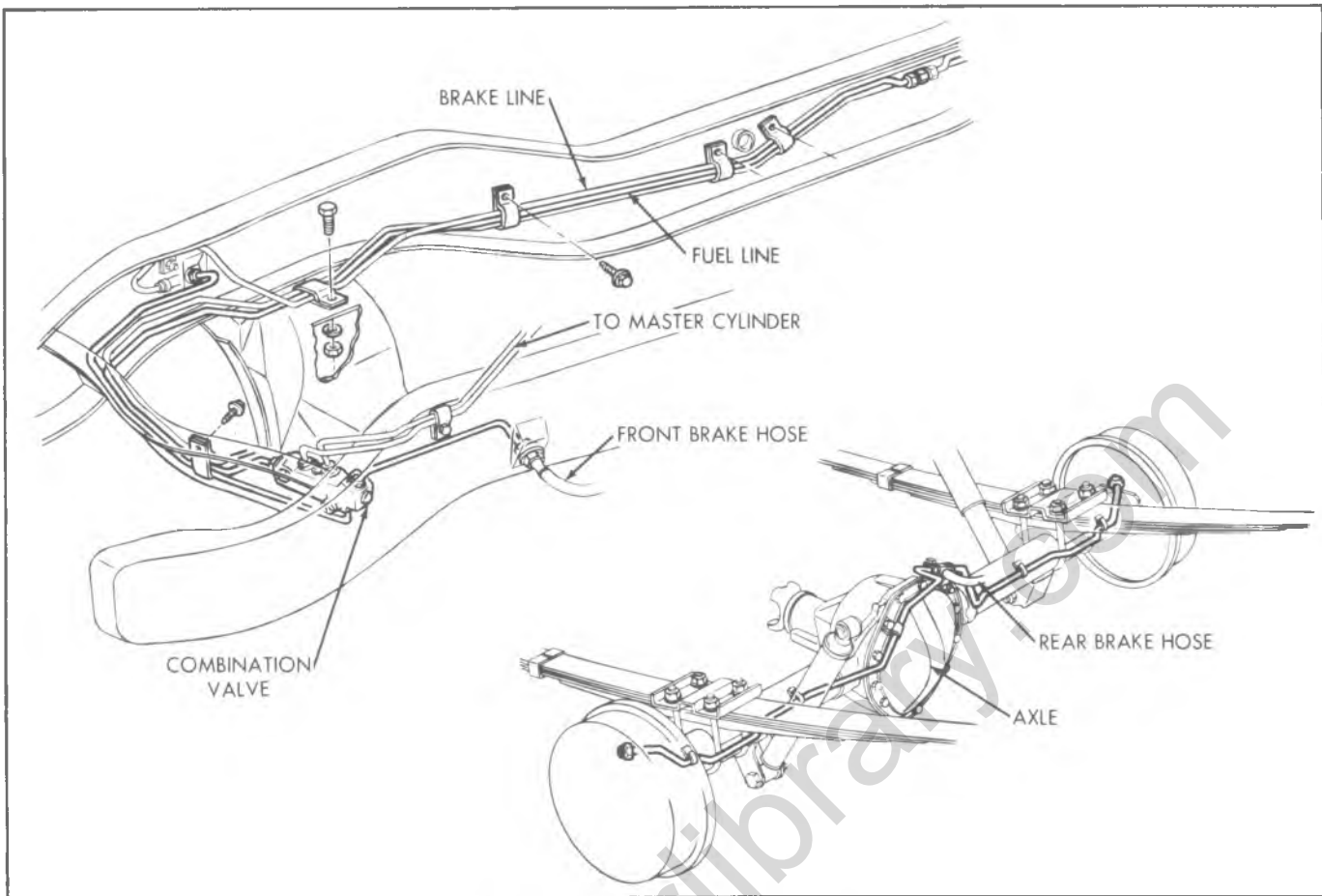

Fig. 33-Brake Line Retainers--Typical

edges with reamer tool provided on the tube cutter.

2. Install compression couplings on tubing and dip end of tubing to be flared in hydraulic brake fluid. This lubrication results in better formation of the flare.
3. Place one-half of the die blocks in the tool body with the counterbored ends toward the ram guide. Now lay the tubing in the block with approximately 1/4" protruding beyond the end.

Fit the other half of the block into the tool body, close the latch plate and tighten the nuts "finger tight."

4. Select the correct size upset flare punch. One end of this punch is hollowed out to gauge the amount of tubing necessary to form a double-lap flare.
5. Slip the punch into the tool body with the gauge end toward the die blocks, install the ram and tap lightly until the punch meets the die blocks and they are forced securely against the stop plate (fig. 36).
6. Using the supplied wrench, draw the latch plate nut down tight to prevent the tube from slipping. Tightening the nuts alternately (beginning with the



Fig. 34-Flaring Tool J-2185

nut at the closed hole in the plate), will prevent distortion of the plate. Remove the punch and the ram. Now reverse the punch and put it back into the tool body. Install the ram and tap it until the upset flare is complete (fig. 37). This completes the first operation. Remove the ram and the punch.

7. To complete the flare, insert the pointed finish flare punch and the ram into the tool body. Tap the ram until a good seat is formed (fig. 38).

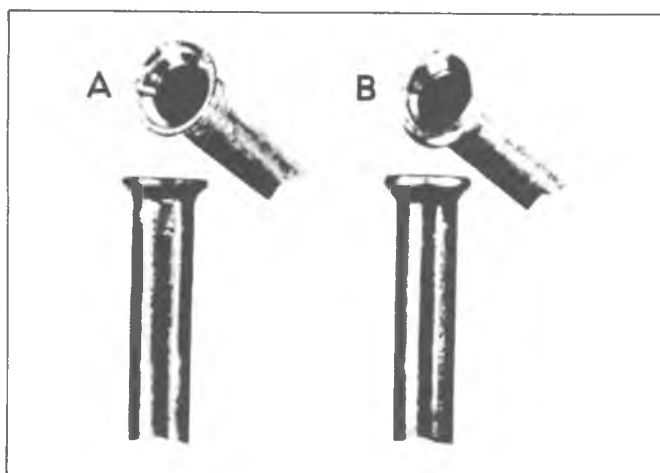

Fig. 35--Single and Double Lap Flare

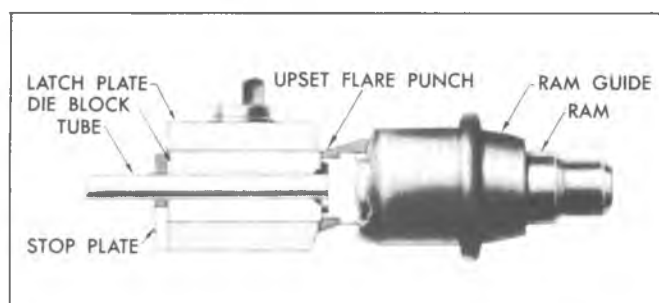

Fig. 36--Positioning Tube

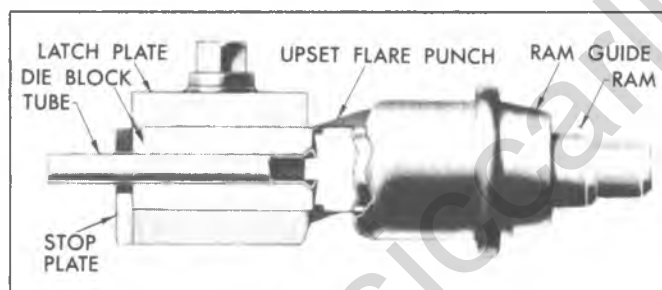

Fig. 37--Flaring Operation

NOTE: The seat should be inspected at intervals during the finishing operation to avoid over-seating.

8. Blow tubing out with compressed air to remove any foreign objects.

## DRUM BRAKE ADJUSTMENT

### Service Brake

Although the brakes are self adjusting a preliminary or initial adjustment may be necessary after the brakes have been relined or replaced, or whenever the length of the adjusting screw has been changed. The final adjustment is made by using the self adjusting feature.

1. With brake drum off, disengage the actuator from the star wheel and rotate the star wheel.

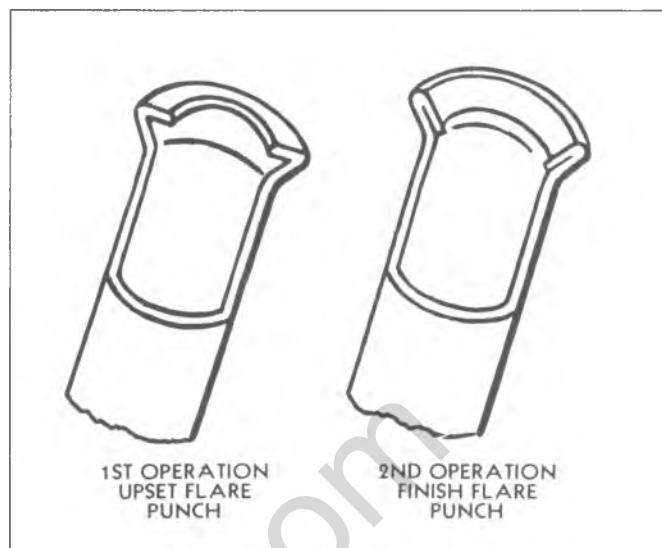

Fig. 38--First and Second Flare

### Recommended Method of Adjustment (Fig. 39)

- a. Use Drum to Brake Shoe Clearance Gauge J-21177 or J-22364 to check the diameter of the drum clearance surface (fig. 39).
- b. Turn the tool to the opposite side and fit over the brake shoes by turning the star wheel until the gauge just slides over the linings (fig. 40).
- c. Rotate the gauge around the brake shoe lining surface to assure proper clearance.

### Alternate Method of Adjustment

- a. Using the brake drum as an adjustment fixture,



Fig. 39--Using Drum-to-Brake Gauge J-21177 or J-22364

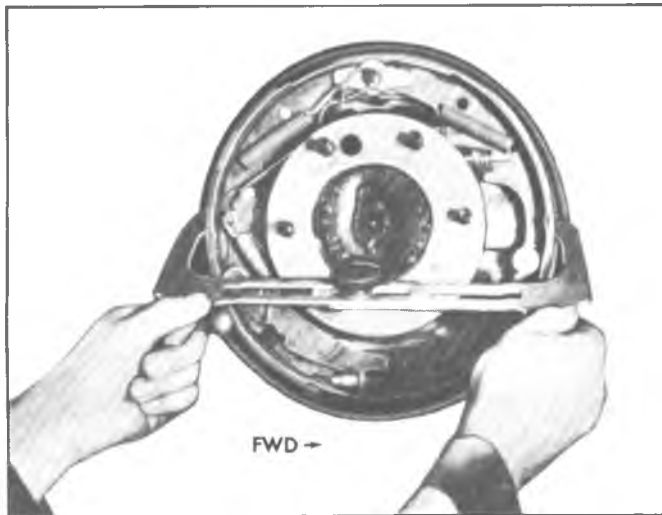

Fig. 40--Setting Lining Clearance with J-21177 or J-22364

turn the star wheel until the drum slides over the brake shoes with a slight drag.

- b. Turn the star wheel 1-1/4 turns to retract the shoes. This will allow sufficient lining to drum clearance so final adjustment may be made as described in Step 3.
2. Install the drum and wheel and remove the vehicle from the jack stands or hoist.

**CAUTION:** If lanced area in drum or flange plate was knocked out, be sure all metal has been removed from brake compartment. Install a new metal hole cover to prevent contamination of the brakes.

Make certain when installing drums that drums are installed in the same position as when removed, with the drum locating tang in line with the locating hole in the axle shaft flange.

3. Make final adjustment by making numerous forward and reverse stops, applying brakes with a firm pedal effort until a satisfactory brake pedal height results.

**CAUTION:** Frequent usage of an automatic transmission forward range to halt reverse vehicle motion may prevent the automatic adjusters from functioning, thereby inducing low pedal heights.

## BRAKE PEDAL ADJUSTMENT

Manual brake vehicles do not incorporate an adjustable push rod. Power brake units incorporate a two-piece push rod. Ordinarily there would be no reason to change the push rod dimension; however, if the rod were inadvertently lengthened or shortened, adjust brake pedal height as shown in Figure 41.

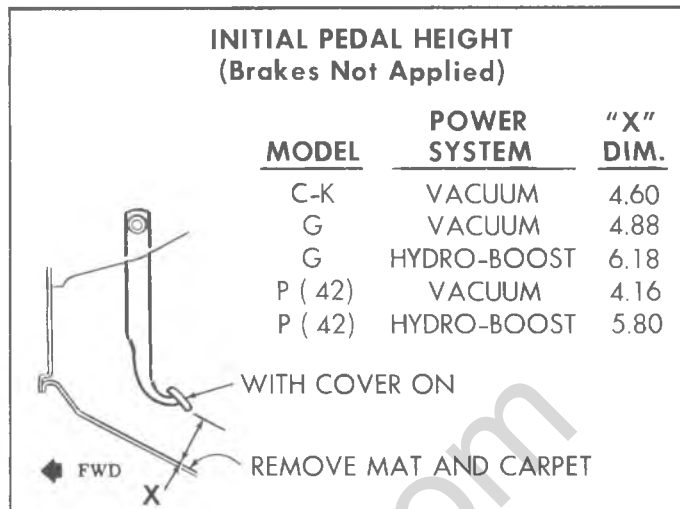

Fig. 41--Brake Pedal Adjustment--Typical

## STOPLAMP SWITCH ADJUSTMENT (Fig. 42)

The stoplamp switch is mounted on a flange protruding from the brake pedal support.

### Adjustment

1. Release the brake pedal to its normal position.
2. Adjust the switch by rotating the switch in its bracket. Electrical contact should be made when the pedal travel (measured at the center of the pedal pad) is 3/8-5/8" (C-K models), approximately 5/8" (P-G models).
3. Tighten switch locknut, if so equipped, and connect electrical harness.

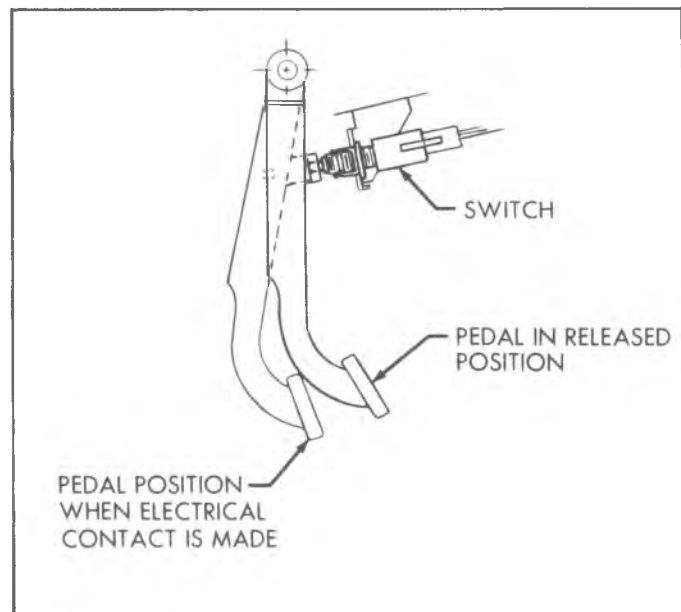

Fig. 42--Stoplamp Switch Adjustment

## PARKING BRAKE—REAR WHEEL

The rear brake assemblies (except RPO H22--where parking brake is mounted on the propeller shaft) serve a dual purpose in that they are utilized both as a hydraulically operated service brake and also as a mechanically operated parking brake. In view of this dual purpose, the service brake must be properly adjusted as a base for parking brake adjustment; conversely the parking brake must be properly adjusted for the service brake to function as intended.

### Inspection

If complete release of the parking brake is not obtained, unless it is forcibly returned to its released position, or if application effort is high, check parking brake assembly for free operation. If operation is sticky or a bind is experienced, correct as follows:

1. Clean and lubricate brake cables and equalizer with Delco Brake Lube #5450032 (or equivalent).
2. Inspect brake assembly for straightness and alignment (replace if necessary).
3. Clean and lubricate parking brake assembly with Delco Brake Lube #5450032 (or equivalent).
4. Checking routing of cables for kinks or binding.

### Adjustment—Foot Pedal Type

**NOTE:** Before adjusting parking brake, check service brake condition and adjustment.

1. Raise vehicle on hoist.
2. Apply parking brake 1 notch from fully released position.
3. Tighten the equalizer nut until a moderate drag is felt when the rear wheels are rotated forward.

**CAUTION:** See *Caution on Page 1 of this section.*

4. Fully release parking brake and rotate the rear wheels. No drag should be present.
5. Remove vehicle from hoist.

### Adjustment—Orscheln Lever Type

1. Turn adjusting knob on parking brake lever counterclockwise to stop.
2. Apply parking brake.
3. Raise vehicle on a hoist.
4. Loosen nut at intermediate cable equalizer and then adjust nut to give light drag at rear wheels.

**CAUTION:** See *Caution on Page 1 of this section.*

5. Readjust parking brake lever knob to give a definite snap-over-center feel.

6. Fully release parking brake and rotate rear wheels. No drag should be present.
7. Remove vehicle from hoist.

## PARKING BRAKE (PROPELLER SHAFT)—INTERNAL EXPANDING

### Adjustment—Drum On

1. Jack up at least one rear wheel. Block wheels and release hand brake.
2. Remove cotter pin and clevis pin connecting pull rod and relay lever. This will assure freedom for full shoe release.

**CAUTION:** *It may be necessary to knock out lanced area in brake drum with punch and hammer to gain entry into adjusting screw through brake drum. Be sure all metal has been removed from parking brake compartment.*

3. Rotate brake drum to bring one of access holes into line with adjusting screw at bottom of shoes.
4. Expand shoes by rotating adjusting screws with screwdriver inserted through hole in drum. Move outer end of screwdriver away from drive shaft. Continue adjustment until shoes are tight against drum and drum cannot be rotated by hand. Back off adjustment ten notches and check drum for free rotation.
5. Place parking brake lever in fully released position. Take up slack in brake linkage by pulling back on cable just enough to overcome spring tension. Adjust clevis of pull rod or front cable to line up with hole in relay levers.
  - a. Insert clevis pin and cotter pin, then tighten clevis locknut.
  - b. Install a new **metal** hole cover in drum to prevent contamination of brake.
  - c. Lower rear wheels. Remove jack and wheel blocks.

**CAUTION:** See *"Caution" on Page 1 of this section.*

### Adjustment—Drum Off

1. With parking brake drum off, use special Tool J-21177 or J-22364, Drum to Brake Shoe Clearance Gauge, to check diameter of drum clearance surface.
2. Turn the tool to the opposite side and fit over brake shoes by turning the star wheel until the gauge just slides over the linings.
3. Rotate the gauge around the brake shoe lining surface to insure proper clearance.
4. Install propeller shaft flange at mainshaft as outlined in transmission section.
5. Lower rear wheels. Remove jack and wheel blocks.

## COMPONENT REPLACEMENT AND REPAIRS

### SHOES AND LININGS—REAR DRUM BRAKES (Fig. 43)

**NOTE:** If brake drums are worn severely, it may be necessary to retract the adjusting screw. To gain access to the adjusting screw star wheel, knock out the lanced area in the brake drum or flange plate using a chisel or similar tool. Release the actuator from the star wheel with a small screwdriver on models with access hole in flange plate or with a wire hook on models with hole in drum. Back off the star wheel with a second screwdriver (as shown in Figures 44 and 45).

**CAUTION:** After knocking out the metal, be sure to remove it from the inside of the drum and clean all metal from the brake compartment. A new metal hole cover must be installed when drum is reinstalled.

Drum brake lining can be inspected through slots in the flange plate. The portion of lining visible through the slot will not necessarily be the area of maximum wear and extra caution is necessary to make sure lining is replaced prior to the point where the remaining thickness, as viewed through the inspection slot, is as follows:

Series 10 (bonded lining), 1/16"

Series 20, 30 (riveted lining), 3/16"

**NOTE:** Riveted linings should be replaced when worn within 1/32" of rivet heads.

#### Removal

**NOTE:** See Section 4 (Rear Suspension and Driveline) for non-demountable type hub and drum removal.

1. Raise the vehicle on hoist.
2. Loosen the parking brake equalizer nut sufficiently to remove all tension from brake cable.
3. Remove brake drums.

**CAUTION:** The brake pedal must not be depressed while drums are removed.

4. Unhook brake shoe pull back springs from anchor pin and link end, using Tool J-8049 (fig. 46).
5. Remove the actuator return spring.
6. Disengage the link end from the anchor pin and then from the secondary shoe.
7. Remove hold-down pins and springs using any suitable tool (fig. 47).
8. Remove the actuator assembly.

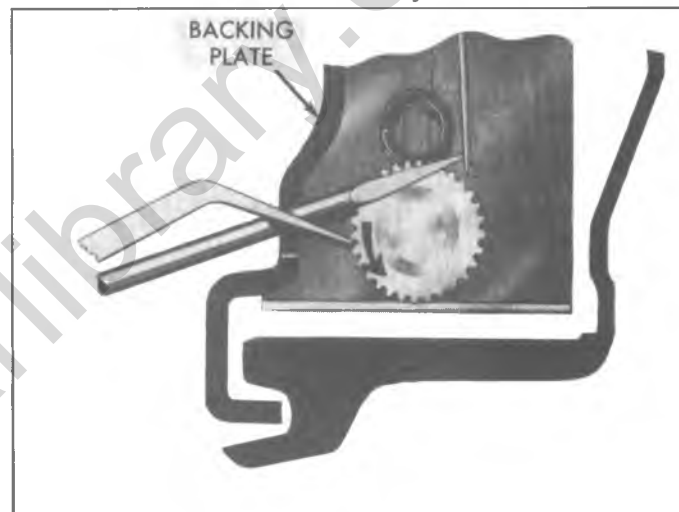

Fig. 44--Flange Plate Access Hole

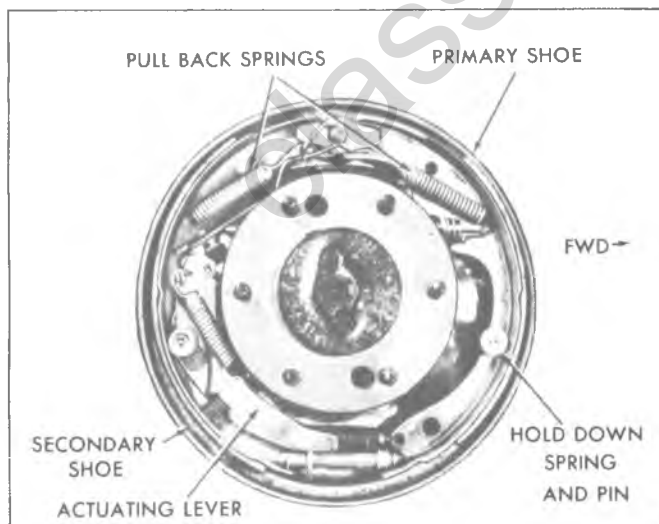

Fig. 43--Rear Brakes

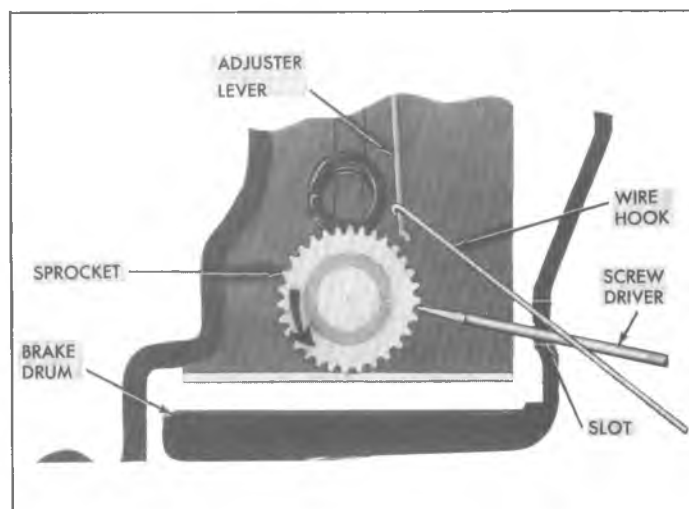

Fig. 45--Brake Drum Access Hole



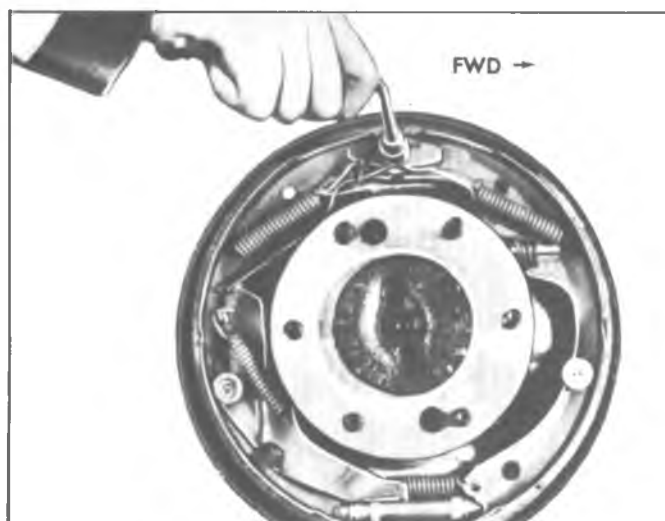

Fig. 46--Unhooking Pull Back Spring

**NOTE:** The actuator, pivot and override spring are an assembly. It is not recommended that they be disassembled for service purposes, unless they are broken. It is much easier to assemble and disassemble the brakes by leaving them intact.

9. Separate the brake shoes by removing adjusting screw and spring.

**CAUTION:** Mark shoe and lining positions if they are to be reinstalled.

10. Remove parking brake lever from secondary brake shoe.

#### Inspection

1. Clean dirt out of brake drum. Inspect drums for roughness, scoring or out-of-round. Replace or recondition drums as necessary.
2. Carefully pull lower edges of wheel cylinder boots away from cylinders and note whether interior is

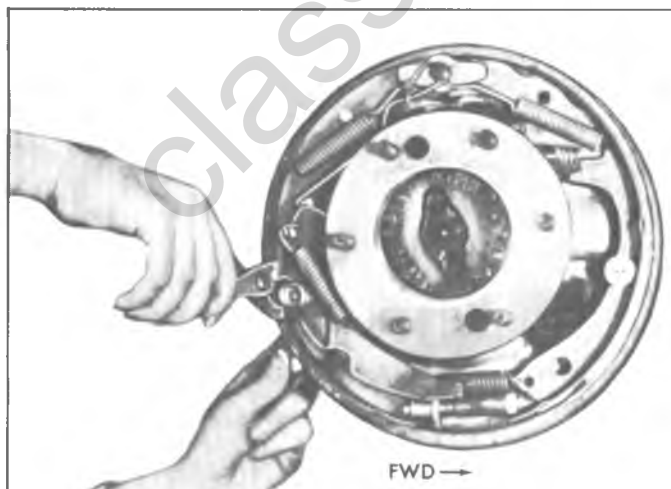

Fig. 47--Removing Hold Down Spring and Pin

wet with brake fluid. Excessive fluid at this point indicates leakage past piston cups requiring overhaul of wheel cylinder.

**NOTE:** A slight amount of fluid is nearly always present and acts as lubricant for the piston.

3. Inspect flange plate for oil leakage past axle shaft oil seals. Install new seals if necessary.
4. Check all brake flange plate attaching bolts to make sure they are tight. Clean all rust and dirt from shoe contact faces on flange plate (fig. 48), using fine emery cloth.

#### Installation

**CAUTION:** Make certain to install recommended shoe and lining assemblies.

1. Inspect new linings and make certain there are no nicks or burrs or bonding material on shoe edge where contact is made with brake flange plate or on any of the contact surfaces.

**CAUTION:** Keep hands clean while handling brake shoes. Do not permit oil or grease to come in contact with linings.

2. Lubricate parking brake cable with Delco Brake Lube #5450032 (or equivalent).
3. Lubricate fulcrum end of parking brake lever and the bolt with Delco Brake Lube #5450032 (or equivalent), then attach lever to secondary shoe with spring washer and lock. Make sure that lever moves freely.

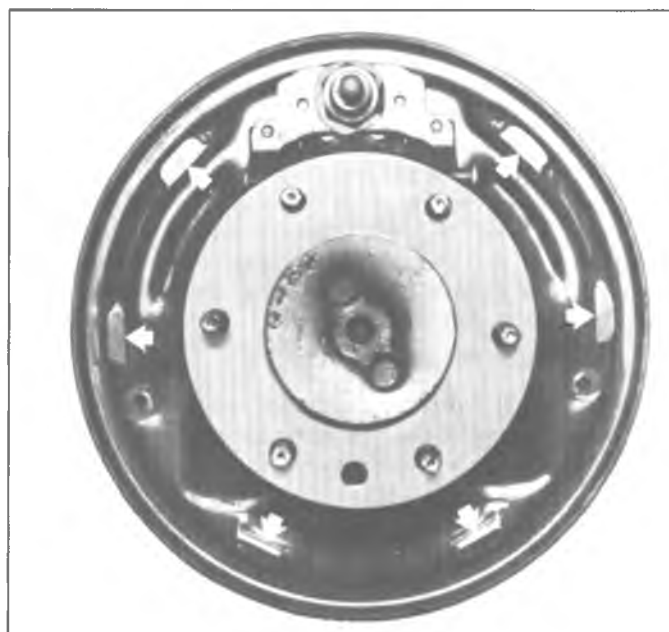

Fig. 48--Flange Plate Contact Surfaces

## 5-26 BRAKES

4. Before installation, make certain the adjusting screw is clean and lubricated properly.

**CAUTION:** Loose adjustment may occur from an adjusting screw that is not properly operating. If the lubricant in the adjusting screw assembly is contaminated or destroyed, the adjusting screw should be thoroughly cleaned and lubricated with Delco Brake Lube # 5450032 (or equivalent).

5. Connect brake shoes together with adjusting screw spring, then place adjusting screw, socket and nut in position.

**CAUTION:** Make sure the proper adjusting screw is used (left hand or right hand). The star wheel should only be installed with the star wheel nearest to the secondary shoe and the adjusting screw spring inserted to prevent interference with the star wheel. Make sure right hand thread adjusting screw is on left side of vehicle and left hand thread adjusting screw is on right side of vehicle. Make certain star wheel lines up with adjusting hole in flange plate.

*If original shoe and lining assemblies are being reinstalled, they must be installed in original positions (as marked at removal).*

6. Install parking brake cable.
7. Secure the primary brake shoe (short lining faces forward) first with the hold down pin and spring. Engage shoes with the wheel cylinder connecting links.
8. Install and secure the actuator assembly and secondary brake shoe with the hold down pin and spring. Position parking brake strut and strut spring.
9. Install guide plate over anchor pin.
10. Install the wire link.

**CAUTION:** Do not hook the wire link over the anchor pin stud with the regular spring hook tool. Fasten the wire link to the actuator assembly first, and then place over the anchor pin stud by hand while holding the adjuster assembly in full down position.

11. Install actuator return spring.

**CAUTION:** Do not pry actuator lever to install return spring. Ease it in place using the end of a screwdriver or other suitable flat tool.

12. If old brake pull back (return) springs are nicked, distorted, or if strength is doubtful, install new springs.
13. Hook springs in shoes using Tool J-8049 by installing the primary spring from the shoe over the anchor pin and then the spring from the secondary shoe over the wire link end (fig. 49).

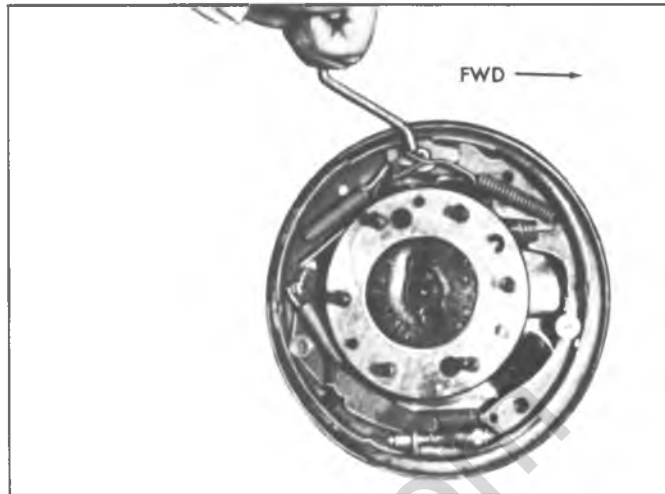

Fig. 49--Installing Pull Back Spring

14. Pry shoes away from the flange plate and lubricate shoe contact surfaces with a thin coating of Delco Brake Lube # 5450032 (or equivalent).

**CAUTION:** Be careful to keep lubricant off facings.

15. After completing installation, make certain the actuator lever functions easily by hand operating the self-adjusting feature (fig. 50).
16. Follow the above procedure for all brakes.
17. Adjust the service brakes and parking brake as outlined under "Maintenance and Adjustments" in this section.
18. Install drum, wheel and tire and lower the vehicle to floor. Test brake operation.

### Relining Brake Shoes

If old brake shoes are to be relined, inspect shoes for distortion and for looseness between the rim and web; these are causes for discarding any shoe. If shoes are serviceable, be governed by the following points in installing new linings:

1. Remove old linings by drilling out rivets. Punching

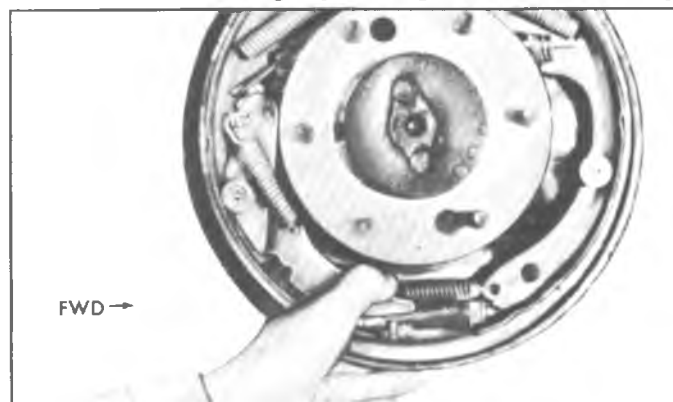

Fig. 50--Checking Actuating Lever

rivets out will distort shoe rim. Thoroughly clean surface of shoe rim and file off any burrs or high spots.

2. Use released brake lining (or equivalent) and the rivets included in lining package which are of the correct size. The rivets must fit the holes with the solid body of rivet extending through the shoe rim, but no farther.

**CAUTION:** *Keep hands clean while handling brake lining. Do not permit oil or grease to come in contact with lining.*

3. Start riveting at center of shoe and lining and work toward the ends. Use a roll set for riveting; a star set might split the tubular end and then the rivet would not fill the hole. The primary lining is shorter than secondary lining, therefore, the rivet holes at each end of the shoe rim are not used.
4. After riveting is completed, lining must seat snugly against shoe with no more than .005" separation midway between rivets. Check with a .004" (Go) and a .006 (No Go) feeler gauge.

## ANCHOR PIN REPLACEMENT

### Removal

1. Raise vehicle on a hoist.
2. Remove wheel and drum as outlined in this section.
3. Remove brake shoe pull back springs, link and guide plate.
4. Disengage anchor pin lock and remove pin from flange plate (Threaded type).

### Installation

1. Position anchor pin to flange plate, install lock washer and torque pin. Lock by peening over washer tabs.

**CAUTION:** *See Caution on Page 1 of this section.*

2. Install brake shoe guide plate, link and pull back springs.
3. Adjust brakes, install drum and wheel as outlined previously in this section.
4. Lower vehicle and test brake operation.

## WHEEL CYLINDER

**CAUTION:** *Always use clean brake fluid to clean wheel cylinder parts. Never use mineral-base cleaning solvents such as gasoline, kerosene, carbon-tetrachloride, acetone, paint thinner or units of like nature as these solvents deteriorate rubber parts, causing them to become soft and swollen in an extremely short time.*

The wheel cylinder boots should be removed from a cylinder body only when they are visibly damaged or

leaking fluid. Wheel cylinders having torn, cut, or heat-cracked boots should be completely overhauled.

## Wheel Cylinder Repair

Wheel cylinders should not be disassembled unless they are leaking or unless new cups and boots are to be installed. It is necessary to remove the wheel cylinder from the flange plate to disassemble, inspect, and overhaul the cylinder.

### Removal

1. Place vehicle on hoist.
2. Remove wheel and tire assembly. Back off brake adjustment, if necessary, and remove drum.
3. Disconnect brake system hydraulic line from cylinder.
4. Remove brake shoe pull back springs.
5. Remove screws securing wheel cylinder to flange plate. Disengage cylinder push rods from brake shoes and remove cylinder.

### Disassembly (Fig. 51)

1. Remove boots from cylinder ends.
2. Remove pistons and cups.

### Inspection and Cleaning

**NOTE:** Staining is not to be confused with corrosion. Corrosion can be identified with pits or excessive bore roughness.

1. Inspect cylinder bore. Check for staining and corrosion. Discard cylinder if corroded.
2. Polish any discolored or stained area with crocus cloth by revolving the cylinder on the cloth supported by a finger. Do not slide the cloth in a lengthwise manner under pressure.

**CAUTION:** *Before washing parts, hands must be clean. Do not wash hands in gasoline or kerosene before cleaning parts. Use soap and water to clean hands.*

3. Wash the cylinder and metal parts in clean brake fluid.
4. Remove excess cleaning fluid from the cylinder. Do not use a rag to dry the cylinder as lint from the rag cannot be kept from the cylinder bore surfaces.
5. Check piston for scratches or other visual damage; replace if necessary.

### Assembly (Fig. 51)

1. Lubricate the cylinder bore with clean brake fluid and insert spring-expander assembly.
2. Install new cups with flat surface toward outer ends of cylinder. Be sure cups are lint and dirt free before insertion. Do not lubricate cups prior to assembly.
3. Install new pistons into cylinder with flat surfaces

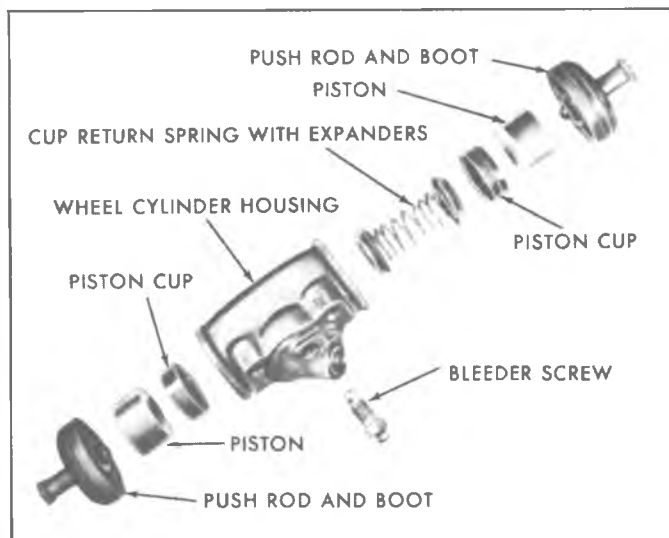

Fig. 51--Wheel Cylinder--Explode

toward center of cylinder. Do not lubricate pistons before installation.

4. Press new boots onto cylinder by hand. Do not lubricate boots prior to installation.

#### Installation

1. Position wheel cylinder to brake flange plate. Install screws and tighten securely.

**CAUTION:** See Caution on Page 1 of this section.

2. Install all push rods and pull back springs.
3. Connect hose or line to wheel cylinder.

**CAUTION:** See Caution on Page 1 of this section.

4. Install drum, wheel and tire assembly.
5. Bleed system as outlined in this section.
6. Remove vehicle from hoist.

#### BRAKE DRUMS

A lanced "knock out" area is provided in the brake flange plate or brake drum for servicing purposes in the event retracting of the brake shoes is required in order to remove the drum.

A small screwdriver or hooked wire may be inserted to disengage the automatic adjuster actuating lever so the star wheel may be turned.

#### Inspecting and Reconditioning

Whenever brake drums are removed, they should be thoroughly cleaned and inspected for cracks, scores, deep grooves and out-of-round. Any of these conditions must be corrected since they can impair the efficiency of brake operation and cause premature failure of other parts.

**WARNING:** A cracked drum is unsafe for further service and must be replaced. Do not attempt to weld a cracked drum.

Smooth up any slight scores by polishing with fine emery cloth. Heavy or extensive scoring will cause excessive brake lining wear, and it will probably be necessary to refinish in order to true up the braking surface.

If the brake linings are slightly worn and the drum is grooved, the drum should be turned just enough to remove grooves. The ridges in the lining should be lightly removed with a lining grinder.

If brake linings are more than half worn but do not need replacement, the drum should be polished with fine emery cloth but should not be turned. At this stage, eliminating all grooves in drum and smoothing the ridges on lining would necessitate removal of too much metal and lining, while if let alone, the grooves and ridges match and satisfactory service can be obtained.

If drum is to be refinished for use with standard size brake facings which are worn very little, only enough metal should be removed to obtain a true smooth braking surface.

A brake drum must not be refinished more than .060" over the maximum standard diameter.

#### Out-Of-Round Or Tapered Drum

A drum that is more than .006 out-of-round on the diameter will result in rough brake application and should be refinished. Out-of-round and the diameter can only be accurately measured with an inside micrometer fitted with proper extension rods.

An out-of-round drum makes accurate brake shoe adjustment impossible and is likely to cause excessive wear of other parts of brake mechanism due to its eccentric action. An out-of-round drum can also cause severe and irregular tire tread wear as well as a pulsating brake pedal. When the braking surface of a brake drum exceeds the factory specification limits in taper and/or being out-of-round, the drum should be turned to true up the braking surface. Out-of-round as well as taper and wear can be accurately measured with an inside micrometer fitted with proper extension rods.

When measuring a drum for out-of-round, taper and wear, take measurements at the open and closed edges of machined surface and at right angles to each other.

#### Micrometer Method (Fig 52)

1. Place the brake drum on a smooth surface.
2. Using micrometers, place the tips at the center of the drum face.
3. While sweeping horizontally and vertically, slowly adjust the micrometer until maximum contact is made. Record this reading.
4. Rotate the drum 45 degrees and repeat Step 3. Continue until 4 readings have been made. The

difference between these 4 readings must not exceed .006.

### Cleaning

New brake drums are given a light coating of rust proofing oil to prevent the formation of rust on the critical braking surfaces during the time that the drums are in storage.

This rust proofing oil must be carefully removed before the drum is placed in service to prevent any of this oil from getting on the brake shoe facings.

It is recommended that a suitable volatile, non-toxic, greaseless type solvent be used to clean the oil from the braking surface of the new brake drums before they are placed in service to insure the cleanest possible surface.

Gasoline or kerosene should not be used as there is danger that a portion of the diluted oil substance may be left on the braking surface.

**NOTE:** All brake drums have a maximum diameter cast into them. This diameter is the maximum wear diameter and not a refinish diameter. Do not refinish a brake drum that will not meet the specifications as shown below after refinishing.

ORIGINAL DIAMETER	MAXIMUM REFINISH DIAMETER	REPLACEMENT (DISCARD) DIAMETER
11.000	11.060	11.090
12.000	12.060	12.090
13.000	13.060	13.090

### SHOE AND LININGS—FRONT DISC BRAKE

The brake linings should be inspected any time that the



Fig. 52--Measuring Drum Diameter

wheels are removed. Check both ends of the outboard shoe by looking in at each end of the caliper. This is the point at which the highest rate of wear normally occurs. At the same time, check the lining thickness on the inboard shoe by looking down through the inspection hole in the top of the caliper--See "Brake Inspection".

The outboard shoes have ears near the outer edge which are bent over at right angles to the shoe. The top ends of the shoe have looped ears with holes in them which the caliper retaining bolts fit through. The large tab at the bottom of the shoe is bent over at a right angle and fits in the cut-out in the outboard section of the caliper.

**NOTE:** Outboard shoes (with formed ears) are designed for original installation only and are fitted to the caliper. The shoes should never be relined or reconditioned for reinstallation.

The inboard shoe and lining has ears on the top ends which fit over the caliper retaining bolts. A special spring inside the hollow piston supports the bottom edge of the inboard shoe.

A spring steel scraper (wear sensor) is riveted to the rear edge of each inner brake shoe (fig. 59). When the shoe lining has worn to within .030" of the rivet heads, the face of the scraper (sensor) contacts the rotor. At this point, an audible high frequency sound (squeal) is emitted to alert the vehicle operator that it is time to replace the brake linings. This warning sound is emitted continuously (provided the wheels are rotating and the brakes are **not** applied). Upon brake application, the warning sound may change or cease completely. If lining wear continues beyond the point at which linings should have been replaced, the warning sound may also cease.

### Removal

1. Remove master cylinder cover and observe brake fluid level in reservoir for front brakes. If reservoir is more than 1/3 full, siphon the necessary amount out to bring the level to 1/3 full; this step is taken to avoid reservoir overflow when the caliper piston is pushed back into its bore.) Discard the brake fluid removed. Never reuse brake fluid.
  2. Raise the vehicle and remove the front wheels.
  3. Push the piston back into its bore. This can be accomplished by using a "C" clamp as shown in Figure 53.
  4. Remove the two mounting bolts which attach the caliper to the support (fig. 54).
  5. Lift the caliper off the disc.
  6. Remove the inboard shoe. Dislodge the outboard shoe and position the caliper on the front suspension arm so that the brake hose will not support the weight of the caliper.
- CAUTION:** Mark shoe positions if they are to be reinstalled.
7. Remove the shoe support spring from the piston.

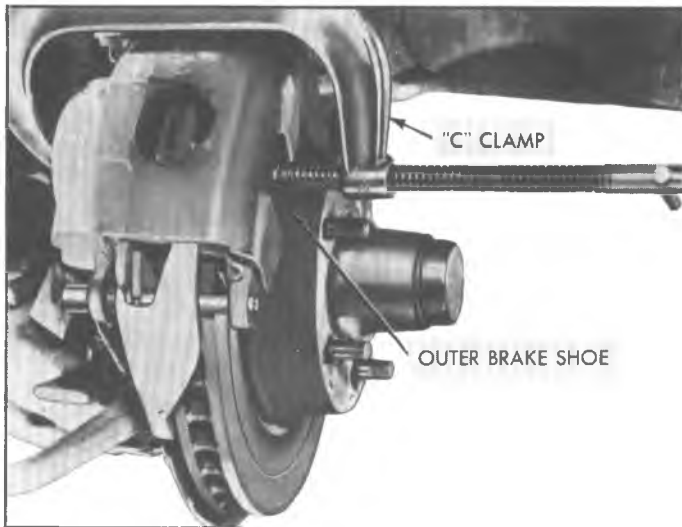

Fig. 53--"C" Clamp for Removal Aid

2. Examine the inside of the caliper for evidence of fluid leakage. If leakage is noted, the caliper should be overhauled.
3. Wipe the inside of the caliper clean, including the exterior of the dust boot. Check the boot for cuts, cracks or other damage.

**CAUTION:** Do not use compressed air to clean the inside of the caliper. This may cause the dust boot to become unseated.

**Installation**

**CAUTION:** If original shoes are being reinstalled, they must be installed in original positions (as marked at removal).

1. Lubricate new sleeves, new rubber bushings, the bushing grooves and the end of the mounting bolts using Delco Silicone Lube #5459912 or equivalent (fig. 55).

**CAUTION:** It is essential that new sleeves and rubber bushings be used and that lubrication instructions be followed in order to ensure the proper functioning of the sliding caliper design.

2. Install the new rubber bushings in the caliper ears.
3. Install the new sleeves to the inboard ears of the caliper.

**NOTE:** Position the sleeve so that the end toward the shoe and lining assembly is flush with the machined surface of the ear.

4. Install the shoe support spring and the "inboard" shoe in the center of the piston cavity as shown in Figure 56.

8. Remove the two sleeves from the inboard ears of the caliper.
9. Remove the four rubber bushings from the grooves in each of the caliper ears.

**Cleaning and Inspection**

**NOTE:** The shoes should be replaced when the lining is worn to approximately 1/32" over the rivet heads. Replace shoes in axle sets.

1. Thoroughly clean the holes and the bushing grooves in the caliper ears and wipe any dirt from the mounting bolts.

**CAUTION:** Do not use abrasives on the bolts since this may damage the plating. If the bolts are damaged or corroded, they should be replaced.

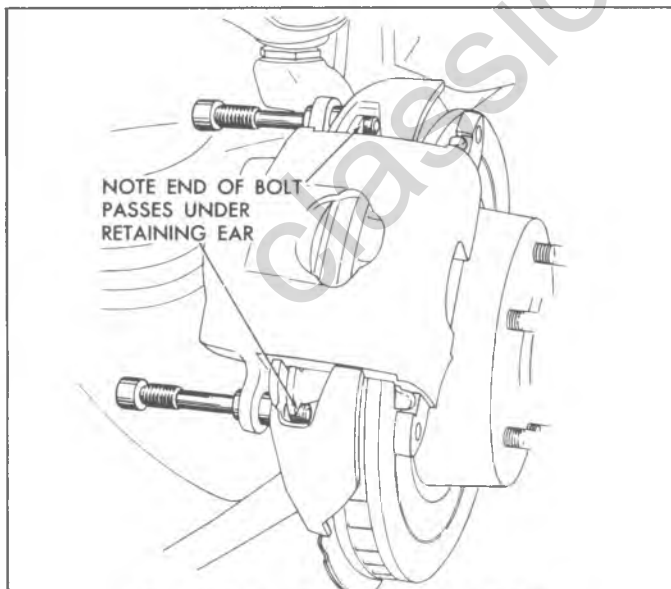

Fig. 54--Caliper Removal and Installation

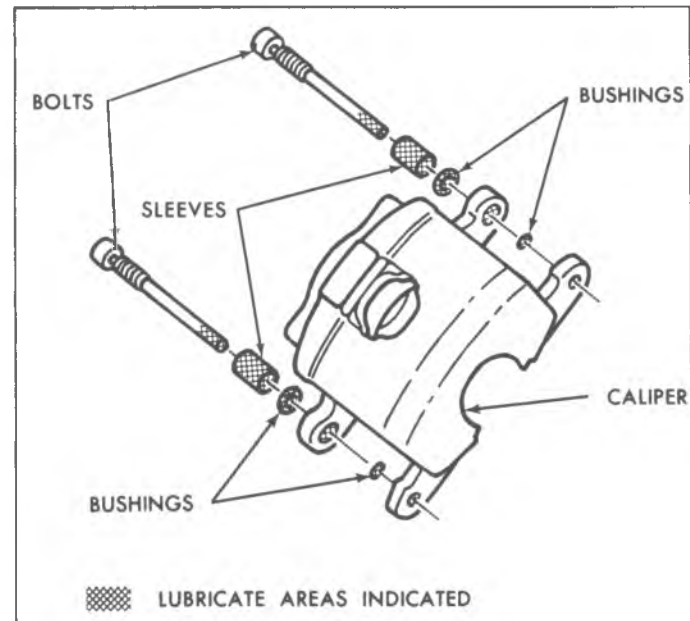

Fig. 55--Lubrication Points

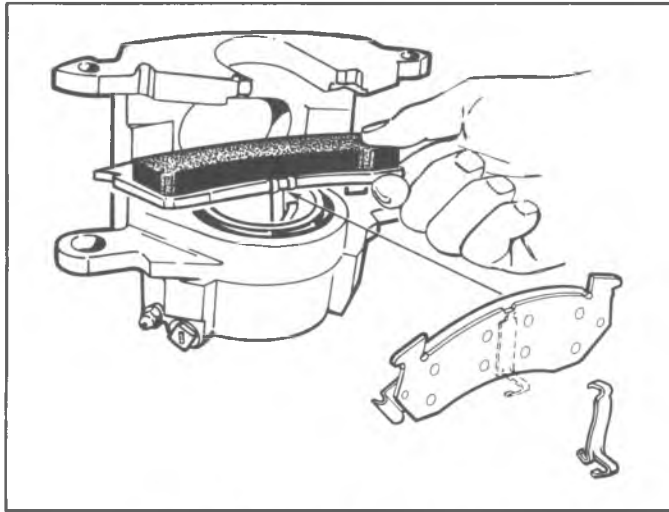

Fig. 56--Installing Support Spring

5. Push down until the shoe lays flat against the caliper (fig. 57).
  6. Position the outboard shoe in the caliper with the ears at the top of the shoe over the caliper ears and the tab at the bottom of the shoe engaged in the caliper cutout.
  7. With both shoes installed, lift up the caliper and rest the bottom edge of the outboard lining on the outer edge of the brake disc to make sure there is no clearance between the tab at the bottom of the outboard shoe and the caliper abutment.
  8. Position the caliper over the brake disc, lining up the holes in the caliper ears with the holes in the mounting bracket.
- NOTE: Make sure that the brake hose is not twisted or kinked.
9. Start the caliper to mounting bracket bolts through the sleeves in the inboard caliper ears and through

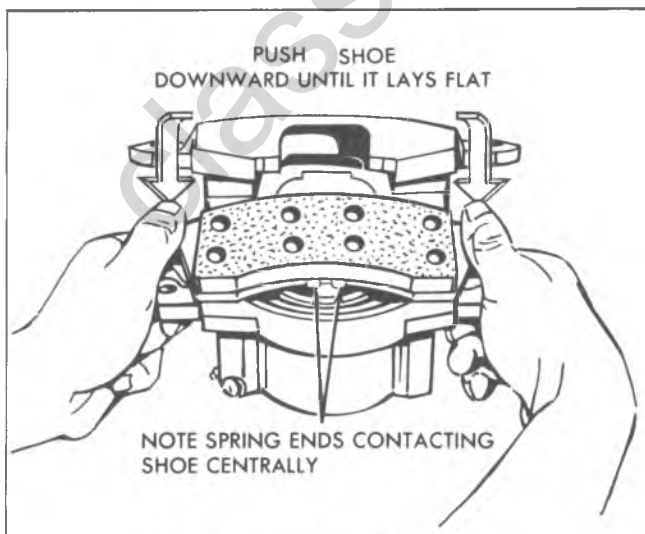

Fig. 57--Installing Shoe to Caliper

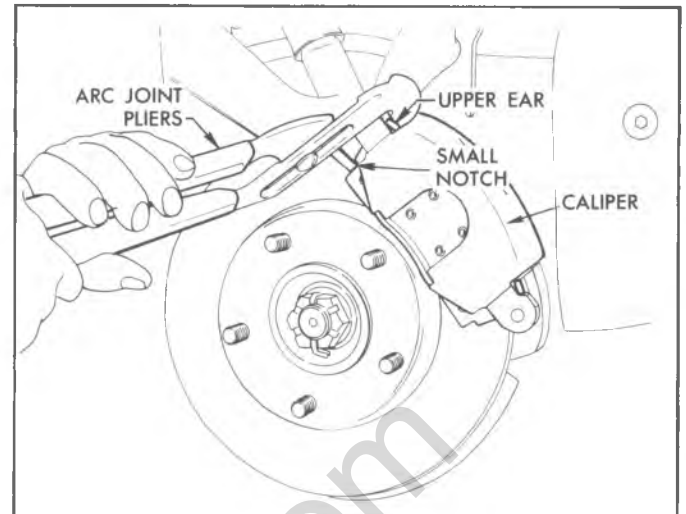

Fig. 58--Fitting Shoe to Caliper

- the mounting bracket, making sure that the ends of the bolts pass under the retaining ears on the inboard shoe.
10. Push the mounting bolts through to engage the holes in the outboard shoes and the outboard caliper ears, threading the mounting bolts into the mounting bracket.
  11. Torque the mounting bolts to 35 ft. lbs.
- CAUTION:** See "Caution" on Page 1 of this section.
12. Pump the brake pedal to seat the linings against the rotors.
  13. Using arc joint pliers, as shown in Figure 58, bend both upper ears of the outboard shoe until no radial clearance exists between the shoe and the caliper housing. Locate pliers on small notch of caliper housing during clinching procedure.

**CAUTION:** If radial clearance exists after initial clinching, repeat Step 13.

NOTE: Outboard shoes (with formed ears) are designed for original installation only and are fitted to the caliper. The shoes should never be relined or re-conditioned for reinstallation.

14. Reinstall the front wheel and lower the vehicle.
15. Add brake fluid to the master cylinder reservoir to bring the fluid level up to within 1/4 inch of the top.

NOTE: Before moving the vehicle, pump the brake pedal several times to make sure that it is firm. Do not move vehicle until a firm pedal is obtained. Check master cylinder fluid level again after pumping the brake pedal.

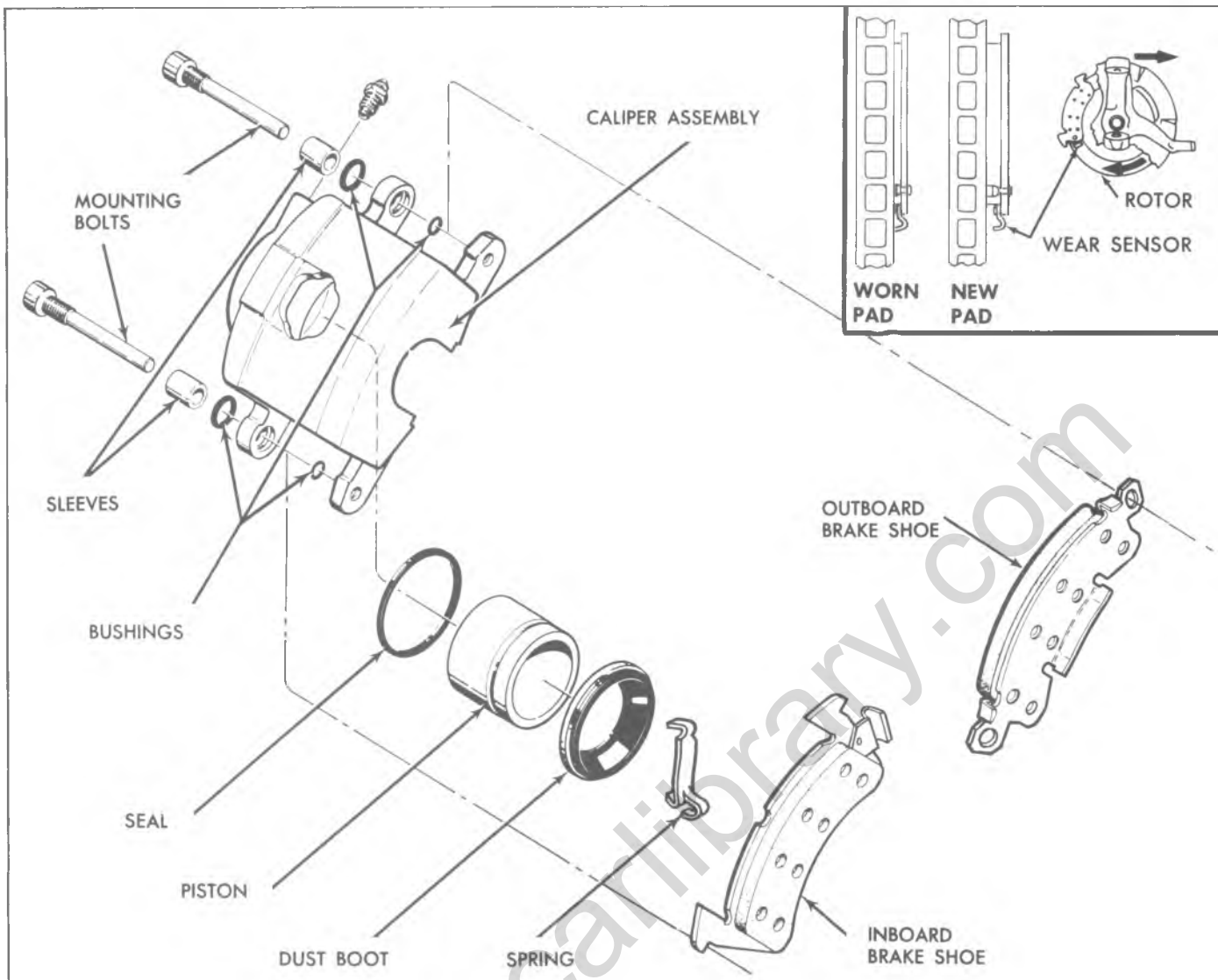

Fig. 59--Caliper Explode

## CALIPER OVERHAUL

**CAUTION:** Always use clean brake fluid to clean any caliper parts. Never use mineral-base cleaning solvents such as gasoline, kerosene, carbon-tetrachloride, acetone, paint thinner or units of like nature as these solvents deteriorate rubber parts, causing them to become soft and swollen in an extremely short time.

### Removal

**CAUTION:** Clean dirt from hose to caliper connection before proceeding with removal.

1. Remove master cylinder cover and observe brake fluid level in reservoir for front brakes. If reservoir is more than 1/3 full, siphon the necessary amount out to bring the level to 1/3 full. This step is taken to avoid reservoir overflow when the caliper piston is pushed back into its bore. Discard the brake fluid removed. Never reuse brake fluid.
2. Raise the vehicle and remove the front wheels.

3. Push the piston back into its bore. This can be accomplished by using a "C" clamp as shown in Figure 53.
4. Remove the hose to caliper bolt and cap or tape the open connections to prevent dirt from entering the hose or caliper. Discard the copper gaskets.
5. Remove the caliper assembly and then remove the brake shoes from the caliper.

**CAUTION:** Mark disc pad locations if pads are to be reinstalled.

### Disassembly

1. Clean the exterior of the caliper using clean brake fluid and place on a clean work surface.
2. Drain the brake fluid from the caliper.



**WARNING:** Do not place the fingers in front of the piston in an attempt to catch or protect it when applying compressed air.

- Using clean shop towels, pad the interior of the caliper and remove the piston by directing compressed air into the caliper inlet hole (fig. 60).

**CAUTION:** Use just enough air pressure to ease the piston out of the bore. Do not blow piston out of the bore.

**NOTE:** An alternate method of removing the piston is to stroke the brake pedal (gently) while the hydraulic lines are still connected. This will push the piston out of the caliper bore.

- Using a screwdriver and caution so as not to scratch the piston bore, pry the dust boot out of the caliper piston bore.
- Using a small piece of wood or plastic, remove the piston seal from its groove in the caliper piston bore.

**CAUTION:** Do not use a metal tool of any kind for this operation as it may damage the bore.

- Remove the bleeder valve from the caliper.
- Remove and discard the sleeves and bushings from the caliper ears.

#### Cleaning and Inspection

**CAUTION:** The dust boot, piston seal, rubber bushings and sleeves are to be replaced each time that the caliper is overhauled. Discard these parts - do not bother to clean and inspect them.

- Clean all parts (other than those mentioned above) in clean brake fluid. Use dry, filtered, compressed air to blow out all passages in the caliper and bleeder valve.

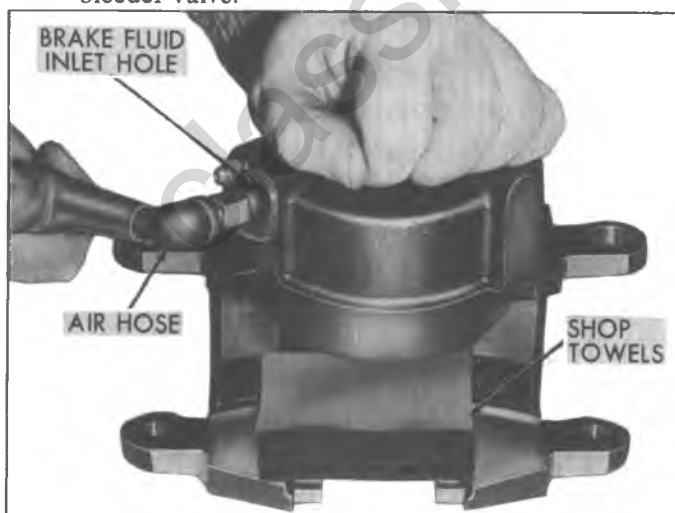

Fig. 60--Removing Piston From Caliper

**CAUTION:** The use of lubricated shop air will leave a film of mineral oil on the metal parts. This may damage rubber parts when they come in contact after reassembly.

- Check the mounting bolts for corrosion or other damage. Do not attempt to clean up the bolts. If they appear corroded - replace them.
- Carefully examine the outside surface of the piston for scoring, nicks, corrosion and worn or damaged chrome plating. If any surface defects are detected, replace the piston.

**CAUTION:** The piston outside diameter is the primary sealing surface in the caliper assembly. It is manufactured and plated to close tolerances. Refinishing by any means or the use of any abrasive is not an acceptable practice.

- Check the bore in the caliper for the same defects as the piston. The piston bore, however, is not plated and stains or minor corrosion can be polished with crocus cloth.

**CAUTION:** Do not use emery cloth or any other form of abrasive. Thoroughly clean the caliper after the use of crocus cloth. If the bore cannot be cleaned up in this manner, replace the caliper.

#### Assembly

- Lubricate the caliper piston bore and the new piston seal with clean brake fluid. Position the seal in the caliper bore groove.
- Lubricate the piston with clean brake fluid and assemble a new boot into the groove in the piston so that the fold faces the open end of the piston as shown in Figure 61.
- Insert the piston into the caliper bore using care not to unseat the seal and force (50 to 100 pounds force required) the piston to the bottom of the bore.



Fig. 61--Installing Boot to Piston

## 5-34 BRAKES

4. Position the dust boot in the caliper counterbore and seat using Boot Installer Tool J-22904 as shown in Figure 62.

**CAUTION:** Check the boot installation to make sure that the retaining ring moulded into the boot is not bent and that the boot is installed below the caliper face and evenly all around.

5. Install the bleeder screw and torque to specifications.

### Installation

**NOTE:** Installation of the caliper and mounting parts (rubber bushings, sleeves, bolts, and shoe and lining assemblies) is the same as for: Brake Shoes and Linings - except for the steps given below.

1. Connect the brake hose to the caliper using new copper gaskets. Torque connector bolt to specifications.

**CAUTION:** Hose must be positioned in the caliper locating gate (between locating beads) to assure proper positioning to caliper.

See "Caution" on page 1 of this section.

2. Bleed the calipers using the method outlined earlier in this section.

### DISC SERVICING

Servicing of the brake disc is extremely critical since accurate control of the disc tolerances is necessary to ensure proper brake operation.

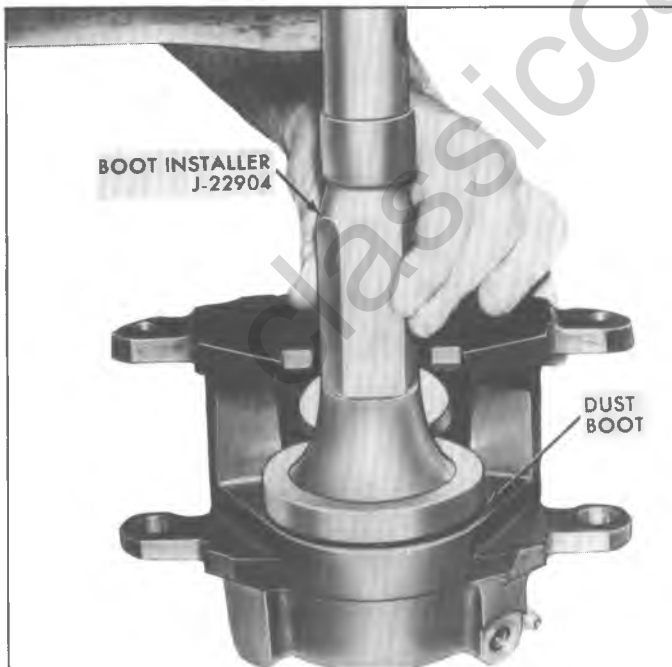

Fig. 62-Installing Boot to Caliper

Brake discs can be refinished if precision equipment is available and a few simple rules are followed. The first thing to do is to determine which of the following will need to be done. RESURFACE, RECONDITION or REPLACE.

**RESURFACE** with a flat sanding disc (with disc rotating) if scoring is light or if the disc surface has severe rust scale.

**RECONDITION** if scoring is deep or if runout, thickness variation, flatness and parallelism are out of specification. Scoring of the brake disc surfaces not exceeding .015 inch in depth, which may result from normal use, is not detrimental to brake operation.

**CAUTION:** Both sides of the disc must be treated in the same manner. If one side needs resurfacing or reconditioning the opposite side should be treated in the same manner.

**REPLACE** if the disc cannot be reconditioned to bring it within specifications and meet the minimum thickness specification after reconditioning.

**CAUTION:** All brake disc have a minimum thickness dimension cast into them. This dimension is the minimum wear dimension and not a refinish dimension. Do not refinish a brake disc that will not meet the specifications as shown below after refinishing:

MINIMUM THICKNESS AFTER REFINISHING	REPLACEMENT (DISCARD) THICKNESS
1.230	1.215
.980	.965

### Minimum Requirements

The disc brake surfaces must meet the following specifications:

1. **BOTH SURFACES MUST BE SQUARE WITH BEARING CUP CENTERLINE WITHIN .003 T.I.R.**

To check, mount the hub and disc to the lathe on the bearing cups—Do not mount on hub surface (fig. 63).

2. **FINISH IS TO BE 20-60 MICRO-INCHES AND MUST NOT BE CIRCUMFERENTIAL (DIRECTIONAL)**

The disc in Figure 64 has a preferred non-directional finish that is achieved with a flat sanding disc.

3. **BOTH SURFACES MUST BE FLAT WITHIN .002 T.I.R.**

This specification must be met to prevent surface taper that could wear shoes on an angle (fig. 65).

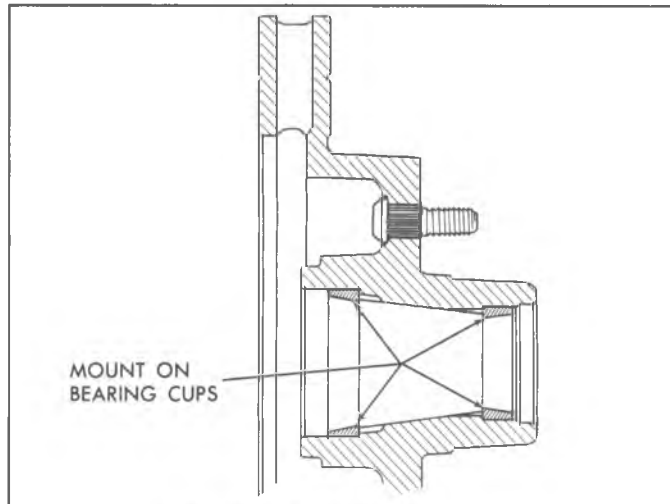

Fig. 63--Hub and Disc Mounting

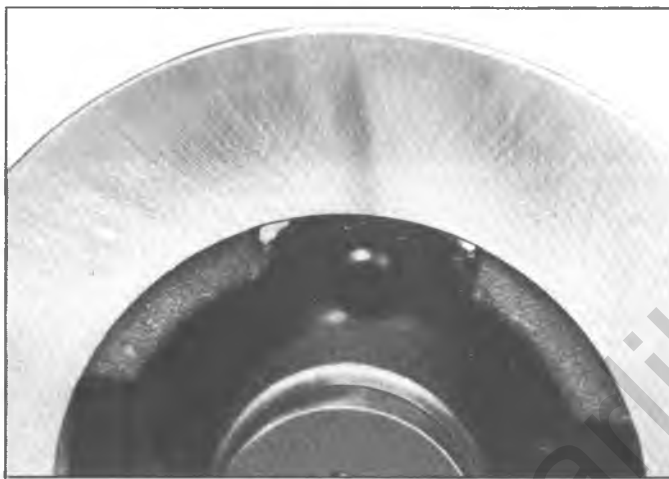

Fig. 64--Disc Non-Directional Finish

4. **MUST BE PARALLEL WITH EACH OTHER WITHIN .003 T.I.R. WHEN CHECKED RADIALLY.**

Disc surfaces, which are not parallel, can cause shoes to wear on an angle (fig. 66).

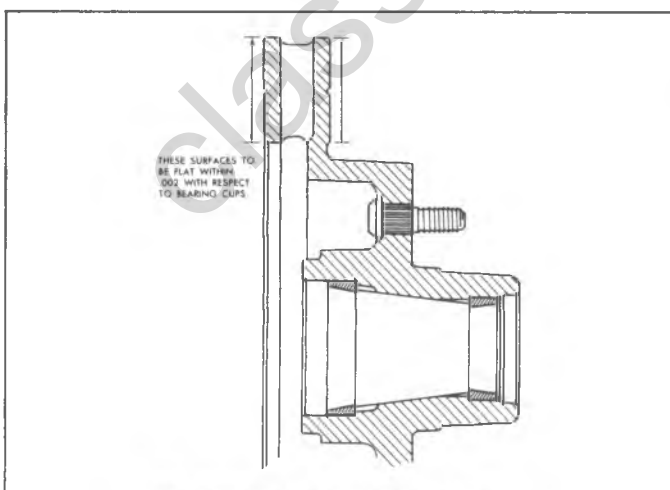

Fig. 65--Checking Surface Flatness

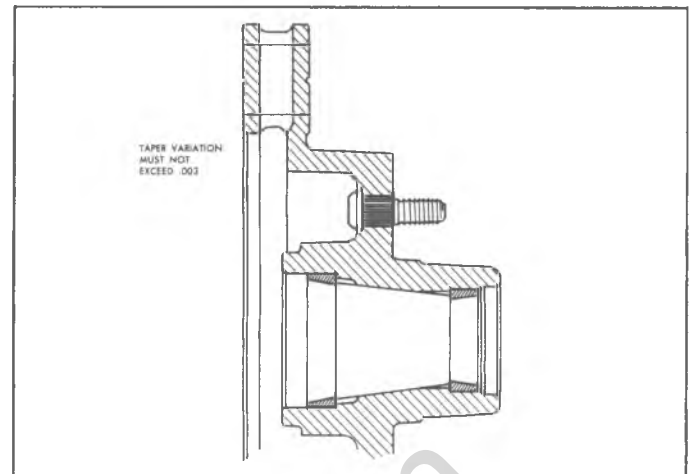

Fig. 66--Checking Surface Parallelism

5. **WHEN MOUNTED ON BEARING CUPS, LATERAL RUN-OUT MUST NOT EXCEED .005 T.I.R. AND MAXIMUM RATE OF CHANGE MUST NOT EXCEED .001 IN 30°.**

Proper lateral runout will prevent disc "wobble" that could knock the piston back into the caliper bore causing increased pedal travel.

To check lateral runout, tighten the wheel bearing adjusting nut until all of the play is out of the bearing. It should be just loose enough to allow the wheel to turn. Mark the disc with chalk every 30° (fig. 67). Fasten a dial indicator to some portion of the suspension so that the point of the stylus contacts the rotor face approximately one inch from the rotor edge. Set the dial at zero and move the rotor one complete rotation, checking the indicator as the rotor moves. After checking the runout, readjust the wheel bearing (See Section 3).

6. **TOTAL CIRCUMFERENTIAL THICKNESS VARIATION AT ANY RADIUS MUST NOT EXCEED .0005 IN 360°.**

Excessive disc thickness variation will cause

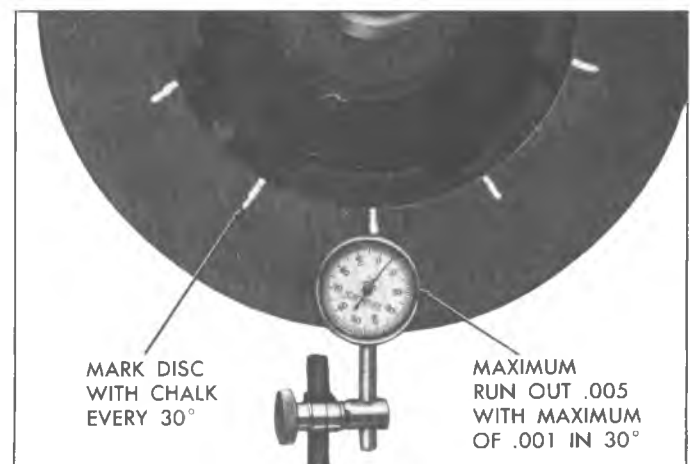

Fig. 67--Checking Lateral Run-Out

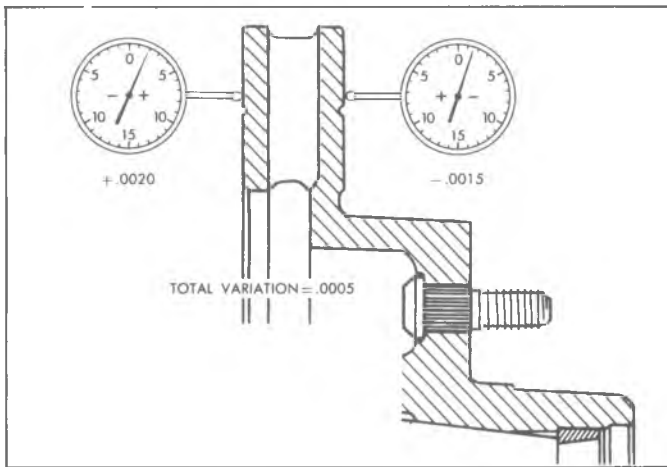

Fig. 68-Checking Circumferential Thickness Variation

brake pedal pulsation.

To check for parallelism, measure the thickness of the rotor at four or more points around the circumference of the rotor. All measurements must be made at the same distance in from the edge of the rotor.

Place indicators opposite each other (fig. 68) and set to zero. As disc is rotated watch each indicator for proper tolerance. A micrometer could be used for this check.

## MASTER CYLINDER

**CAUTION:** Always use clean brake fluid to clean any master cylinder parts. Never use mineral-base cleaning solvents such as gasoline, kerosene, carbon-tetrachloride, acetone, paint thinner or units of like nature as these solvents deteriorate rubber parts, causing them to become soft and swollen in an extremely short time.

### Removal

1. Wipe master cylinder and lines clean with a clean cloth. Place dry cloths below master cylinder areas to absorb any fluid spillage.
2. Disconnect hydraulic lines at master cylinder. Cover line ends with clean lint-free material to prevent foreign matter from entering the system.
3. Disconnect the push rod from the brake pedal (manual brake vehicles).
4. Remove the master cylinder mounting bolts or stud nuts and remove the master cylinder.

### Installation

1. Assemble the push rod through the push rod retainer, if it has been disassembled.
2. Push the retainer over the end of the master cylinder. Assemble new boot over push rod and

press it down over the push rod retainer. Slide new mounting gasket into position. Secure the master cylinder to the dash panel with mounting bolts or stud nuts.

**CAUTION:** See "Caution" on Page 1 of this section.

3. Connect the push rod clevis to the brake pedal with pin and retainer (manual brake vehicles).
4. Connect the brake lines to the master cylinder.

**CAUTION:** See "Caution" on page 1 of this section.

5. Fill the master cylinder reservoirs to the levels shown in Figure 30. Bleed the brake system as outlined in this section.
6. Check brake pedal and stoplamp switch adjustment as outlined earlier in this section.

## MASTER CYLINDER OVERHAUL (Fig. 69)

### Disassembly

1. Remove the small secondary piston stop screw from the bottom of the front fluid reservoir of the master cylinder.

**CAUTION:** When placing the master cylinder in a vise, do not tighten too tightly as damage to the cylinder could result.

2. Place the master cylinder in the vise so that the lock ring can be removed from the small groove in the I.D. of the bore. Remove the lock ring and primary piston assembly. Remove the secondary piston, secondary piston spring and retainer by blowing air through the stop screw hole. If air is not available, a piece of wire may be used. Bend approximately 1/4" of one end of the wire into a right angle. Hook this end under the edge of the secondary piston and pull the secondary piston from the bore.

**NOTE:** The brass tube-fitting insert should not be removed unless visual inspection indicates the insert is damaged.

3. To replace a defective insert the following procedure should be practiced:
  - a. Place the master cylinder in a vise, so that the outlet holes are up. Enlarge the outlet holes in the tube seats using a 13/64" drill. Tape a 1/4" - 20 thread in these holes. Place a heavy washer over the outlet on the master cylinder and thread a 1/4" - 20 x 3/4" hex head bolt into the tube seat. Tighten the bolt until the tube seat is unseated.
  - b. A more preferable way to remove a defective insert involves use of a self-tapping screw and a claw hammer. With a box-end or socket wrench, thread a #6 - 32 x 5/8" long self-tapping screw into the tube-fitting insert. Using the claw end of the hammer, remove the screw and insert.

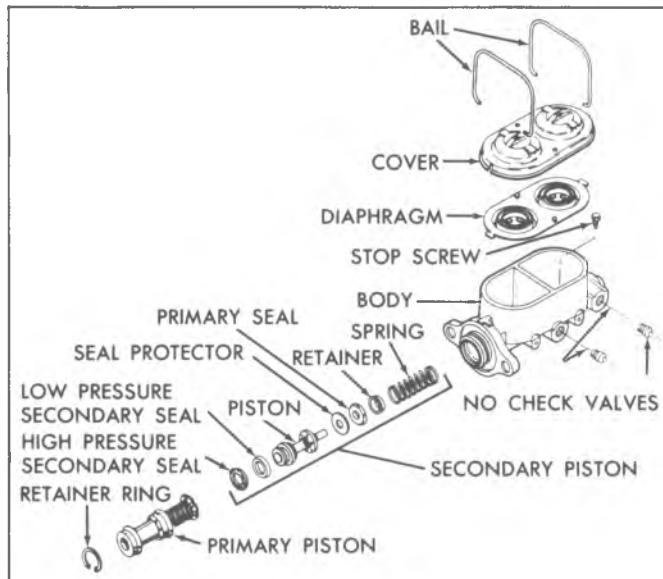

Fig. 69--Master Cylinder--Explode

- Remove the casting from the vise and inspect the bore for corrosion, pits and foreign matter. Be sure the outlet ports are clean. Inspect the fluid reservoirs for foreign matter. Check the bypass and compensating ports to the master cylinder bore to determine if they are unrestricted.
- Remove the primary seal, primary seal protector and secondary seals from the secondary piston.

#### Cleaning

Use clean brake fluid to thoroughly clean all reusable brake parts. Immerse in the cleaning fluid and brush metal parts with hair brush to remove foreign matter. Blow out all passages, orifices and valve holes. Place cleaned parts on clean paper or lintfree clean cloth. If slight rust is found inside either the front or rear half housing assemblies, polish clean with crocus cloth or fine emery paper, washing clean afterwards.

**CAUTION:** Be sure to keep parts clean until re-assembly. Re-wash at re-assembly if there is any occasion to doubt cleanliness - such as parts dropped or left exposed for eight hours or longer.

*IF there is any suspicion of contamination or any evidence of corrosion, completely flush the vehicle hydraulic brake system in accordance with this shop manual. Failure to clean the hydraulic brake system can result in early repetition of trouble. Use of gasoline, kerosene, anti-freeze, alcohol or any other cleaner, with even a trace of mineral oil, will damage rubber parts.*

#### Rubber Parts

Wipe fluid from the rubber parts and carefully inspect

each rubber part for cuts, nicks or other damage. These parts are the key to the control of fluid flow. If the unit is in for overhaul, or if there is any question as to the serviceability of rubber parts, **REPLACE** them.

Badly damaged items, or those which would take extensive work or time to repair, should be replaced. In case of doubt, install new parts. Do not rely on the brake unit being overhauled at an early or proper interval. New parts will provide more satisfactory service, even if the brake unit is allowed to go beyond the desired overhaul period.

#### Assembly

If the brass tube inserts were removed, place the master cylinder in a vise so that the outlet holes are up. Position the new brass tube inserts in the outlet holes, making sure they are not cocked. The recommended method of seating these inserts is to thread a spare brake line tube nut into each outlet and turn the nuts down until the insert bottoms. **Remove the tube nut and check the outlet hole for loose brass burrs, which might have been turned up when the insert was pressed into position.**

Each vehicle application of these cylinders is designed to produce the correct displacement of fluid from both the front and rear chambers under normal, failed and partially failed conditions. Cylinders are designed so that this variable displacement requirement is controlled within each bore size by the secondary piston.

Because the pistons vary in length, it is necessary to mark them with identification rings. It is imperative that exact replacements be made when servicing the master cylinders.

With all of the variables to be found in master cylinders, which look similar externally, it is important that the complete assemblies be properly identified. For this purpose a two-letter metal stamp will be found on the end of each master cylinder. This two-letter stamp indicates the displacement capabilities of that particular master cylinder. It is, therefore, mandatory that when master cylinders are replaced, they are replaced with cylinders bearing the same two-letter stamp.

- Place new secondary seals in the two grooves in the flat end of the secondary piston assembly. The seal which is nearest the flat end will have its lip facing toward this flat end. On Delco units, the seal in the second groove should have its lips facing toward the end of the secondary piston which contains the small compensating holes. On Bendix units, the seal in the second groove is an "O" ring seal.
- Assemble a new primary seal and primary seal protector over the end of the secondary piston opposite the secondary seals, so that the flat side of the seal seats against the flange of the piston which contains the small compensating holes.
- In order to ensure a correct assembly of the primary piston assembly, a complete primary piston assembly is included in the repair kits.

## 5-38 BRAKES

- Coat the bore of the master cylinder with clean brake fluid. Coat the primary and secondary seals on the secondary piston with clean brake fluid. Insert the secondary piston spring retainer into the secondary piston spring. Place the retainer and spring down over the end of the secondary piston so that the retainer locates inside the lips of the primary seal.
- Hold the master cylinder with the open end of the bore so that the spring will seat in against the closed end of the bore. Using a small wooden rod to push the secondary piston to seat.
- Place the master cylinder in a vise with the open end of the bore up. Coat the primary and secondary seals on the primary piston with clean brake fluid. Push the primary piston, secondary piston stop first, into the bore of the master cylinder. Hold the piston down and snap the lock ring into position in the small groove in the I.D. of the bore.

**CAUTION:** Do not tighten vise too tightly as damage to the master cylinder could result.

- Continue to hold the primary piston down. This will also move the secondary piston forward and will ensure that the secondary piston will be forward far enough to clear the stop screw hole, which is in the bottom of the front fluid reservoir. The stop screw is now positioned in its hole and tightened to a torque of 25-40 inch pounds.
- CAUTION:** See "Caution" on Page 1 of this section.
- Install the reservoir diaphragm in the reservoir cover and install the cover on the master cylinder. Assemble the bail wire(s) into position to retain the reservoir cover. The master cylinder is now ready for "Bench Bleeding".

### BENCH BLEEDING MASTER CYLINDER

- Install plugs in both outlet ports.
- NOTE: Plastic plugs that come with a replacement cylinder are recommended for this operation.
- Clamp the master cylinder in a bench vise with the front end tilted slightly down.
- CAUTION:** Do not tighten vise too tightly as damage to the master cylinder could result.
- Fill both reservoirs with clean brake fluid.
  - Insert a rod with a smooth round end to the primary piston and press in to compress the piston return spring.
  - Release pressure on rod. Watch for air bubbles in the reservoir fluid.
  - Repeat Step 5 as long as bubbles appear.

- Reposition master cylinder in vise so that the front end is tilted slightly up.
- Repeat Steps 4-5-6.
- Install diaphragm and cover on reservoir.

### BRAKE COMBINATION VALVE

#### Metering, Warning and Proportioning (Fig. 70)

NOTE: The brake combination valve is a non-adjustable, non-serviceable valve. If defective it must be replaced.

#### Function

##### Metering Valve

This section of the valve operates to "hold-off" hydraulic flow to the front disc brakes until a predetermined pressure is reached. This "hold-off" action allows the rear drum brakes to build up sufficient hydraulic pressure to overcome the force of their retracting springs. This metering or hold-off valve then provides for balanced braking.

NOTE: When bleeding the brakes; the pin in the end of the metering portion of the combination valve must be held in the open position (not allowed to close). This can be accomplished by installing Tool J-23709 under the mounting bolt and depressing the pin in the end of the valve. Be sure to re-torque the mounting bolt after removing Tool J-23709 (fig. 28).

##### Warning Switch

The warning switch is the pressure differential type. It is wired electrically to the warning lamp on the instrument panel to warn the vehicle operator of a pressure differential between the front and rear hydraulic systems. Once the switch is activated "on", it will not "reset" until the defect in the hydraulic system has been repaired. Hydraulic reset to the "off" position occurs with the application of equal front and rear pressures.

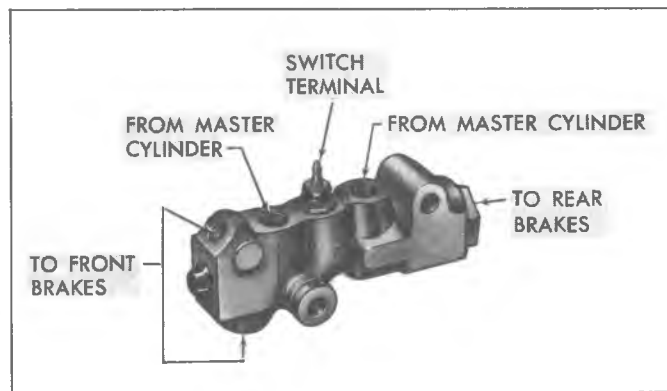

Fig. 70-Combination Valve

### Proportioning Valve

The function of this valve is prevent premature rear wheel slide. Line pressure is allowed to increase normally up to a certain point (determined by vehicle weight and braking distribution). When the predetermined pressure is reached, the valve begins to function and limit the amount of increase in hydraulic pressure passed to the rear brakes. This prevents the rear brakes from locking up before the full effective braking effort is produced by the front disc brakes.

**NOTE:** In the event of "front hydraulic system failure" the proportioning valve has a "by-pass" feature that assures full system pressure to the rear brakes.

### Removal

1. Disconnect electrical lead.
2. Place dry rags below valve to absorb any fluid spillage.
3. Wipe off any dirt and disconnect hydraulic lines from valve--cover open lines to prevent foreign matter from entering the system.
4. Remove mounting screws and remove valve.

### Installation

1. Make sure new switch is clean and free of lint. If any doubt exists, wash the switch in clean brake fluid.
2. Place new switch in position and secure with screws.

**CAUTION:** See "Caution" on Page 1 of this section.

3. Connect hydraulic lines to valve.

**CAUTION:** See "Caution" on Page 1 of this section.

4. Connect switch electrical lead.
5. Bleed the brake system.

### Brake Warning Light Checking

1. Set parking brake and turn the ignition key to "ON".
2. Warning lamp should light.
3. If lamp does not light, bulb is burned out or electrical circuit is defective.
4. Turn ignition key off.
5. Replace bulb or repair circuit as necessary.

### Testing Warning Switch

1. Raise vehicle on a hoist and attach a bleeder hose to a rear brake bleed screw and immerse the other end of hose in a container partially filled with clean brake fluid. Be sure master cylinder reservoirs are full.

**NOTE:** When bleeding the brakes; the pin in the end of the metering portion of the

combination valve must be held in the open position (not allowed to close). This can be accomplished by installing Tool J-23709 under the mounting bolt and depressing the pin a slight amount. Be sure to re-torque the mounting bolt after removing Tool J-23709 (fig. 28).

**CAUTION:** See "Caution" on Page 1 of this section.

2. Turn ignition key "ON". Open bleed screw while helper applies heavy pressure to brake pedal. Warning lamp should light. Close bleed screw before helper releases pedal.

**NOTE:** To "reset" switch, apply heavy pedal force. This force will apply hydraulic pressure which re-centers the switch contact.

3. Attach bleeder hose to front brake bleed screw and repeat Step 2.
4. Turn ignition key off. See Note under Step 2.
5. Lower vehicle to floor.

**NOTE:** If warning lamp does not light during Steps 2 and 3 but does light when the parking brake is set, warning light switch is defective. Do not attempt to repair switch. A defective switch must be replaced with a new combination valve assembly.

**CAUTION:** Caution should be taken to prevent air from entering system during checks on switch.

The recommended checking interval should be 24 months or 24,000 miles, any time major brake work is done or any time a customer complains of excessive pedal travel.

### BRAKE PEDAL—SERVICE BRAKE (Fig. 71)

**NOTE:** The brake pedal mounting is an integral design with the clutch pedal (except automatic transmission), necessitating the removal of the clutch pedal before removing the brake pedal.

### Removal

1. Remove the pull back spring from the body or brake pedal support bracket.
2. **Manual Transmission Vehicles**--Remove the clutch pedal as outlined under "Clutch Pedal" in Section 7.
3. **Automatic Transmission Vehicles**--Remove pedal pivot bolt nut or pivot pin retainer and remove bolt or pin and bushings.
3. **P Models**--Remove the sleeve assembly screw attachment and remove sleeve.

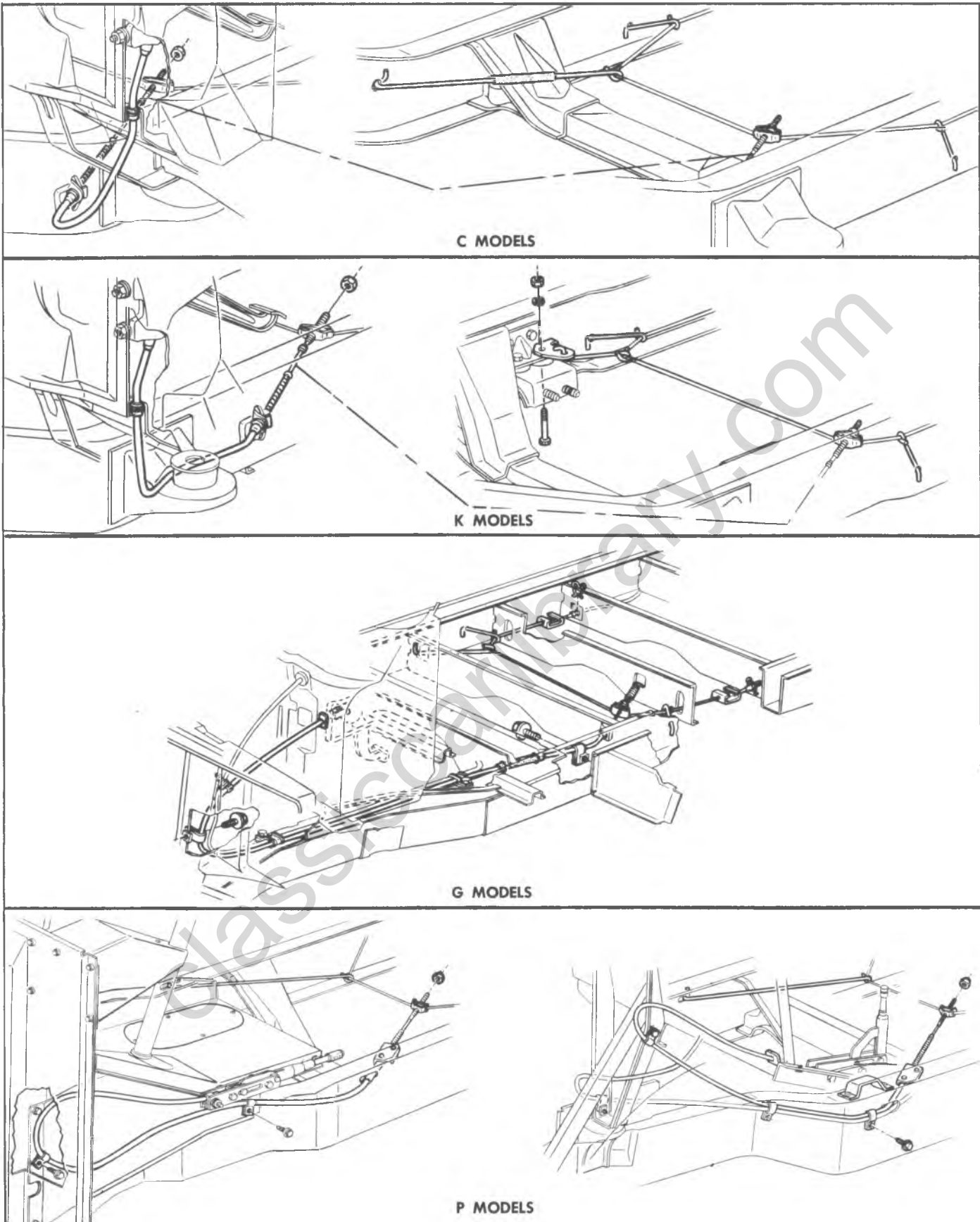

Fig. 73--Parking Brake System (Typical)



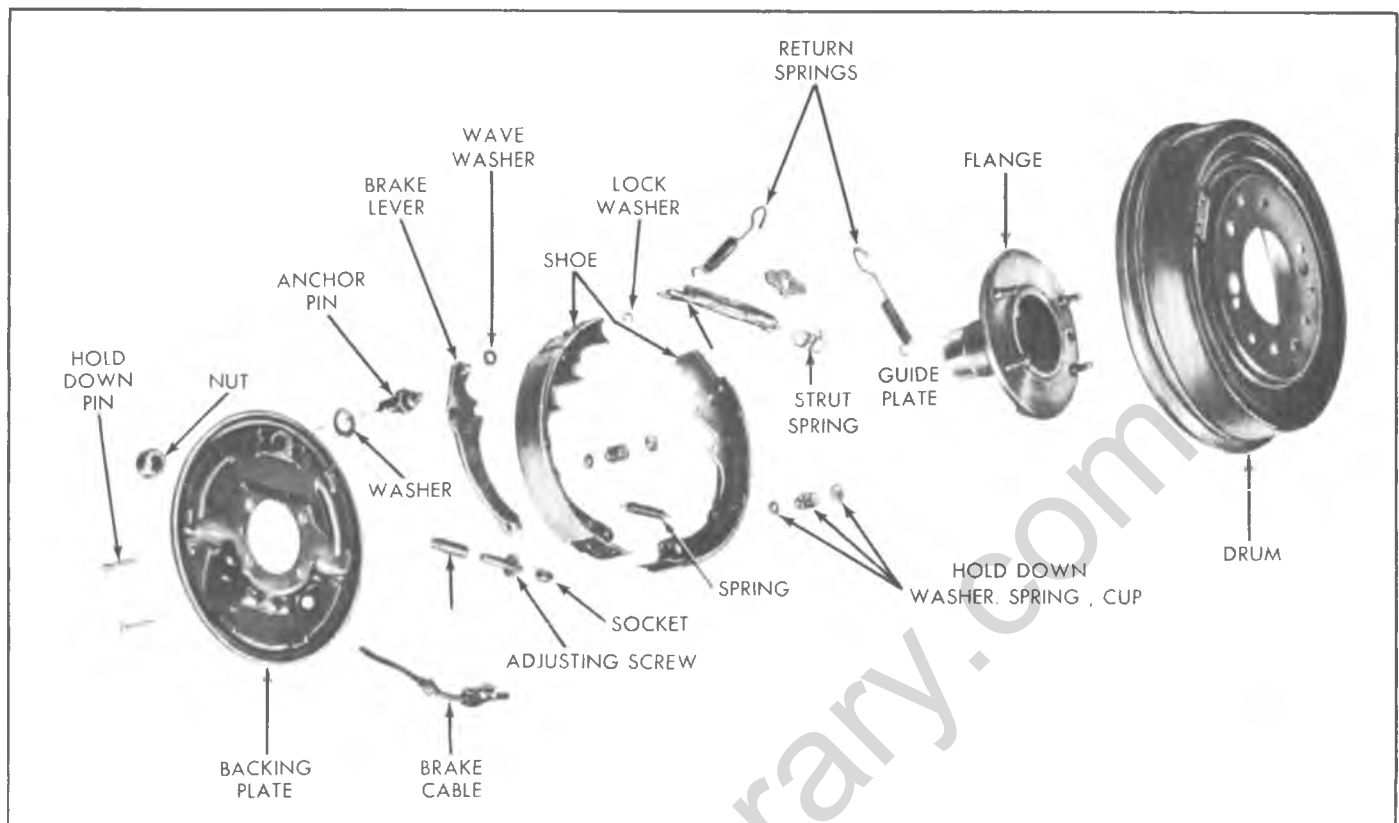

Fig. 74-Internal Expanding Brake Components

tang of washer over reinforcement and side of washer over hex of anchor pin.

**CAUTION:** See "Caution" on Page 1 of this section.

5. Install lever on cable by compressing spring and inserting cable in channel of lever. Release spring.
6. Install primary shoe (short lining) to lever as follows: Place pin in lever, place washer on pin and push pin through hole in primary shoe. Fasten parts together by installing the clip in groove of pin.
- CAUTION:** See "Caution" on Page 1 of this section.
7. Fasten two brake shoes and linings together by installing connecting spring. Move the shoes toward each other and install adjusting screw.
8. Lubricate the flange plate contact surfaces with a very light coat of Delco Brake Lube #5450032 (or equivalent).
9. Place shoe and linings in position on flange plate.  
NOTE: When facing the brake assembly, the shoe with the short lining should be to the left with the lever assembled to it.
10. Pull brake shoes apart and install strut lever and spring between them. The loop on the strut spring should be in the "up" position.
11. Install hold down pins, washers, springs and cups from flange plate to shoes.

12. Place guide plate on anchor pin.
13. Install pull back springs.
14. Remove the "knock out" plug (if necessary) and install a new metal plug in the brake drum adjusting hole.
15. Install the brake drum.
16. Install the propeller shaft.

### REAR BRAKES RPO H-22 (Fig. 75)

Brake shoe adjustment takes place when brakes are applied with a firm pedal effort while the vehicle is backing up. Applying the brakes moves actuators which turn the star wheels and rotate the adjusting screws outward from the anchor brackets. This action adjusts the shoe until clearance between the lining and drum is within proper limits.

Should low pedal heights be encountered, it is recommended that numerous forward and reverse stops be performed with a firm pedal effort until a satisfactory pedal height results.

### Retracting Self Adjusters

Access holes are located in the flange plate. These holes are for service purposes in the event retracting of the brake shoes is required to remove the drum. In order to back off the adjuster, insert a screwdriver, index a corner of the screwdriver blade with the hole in the actuating

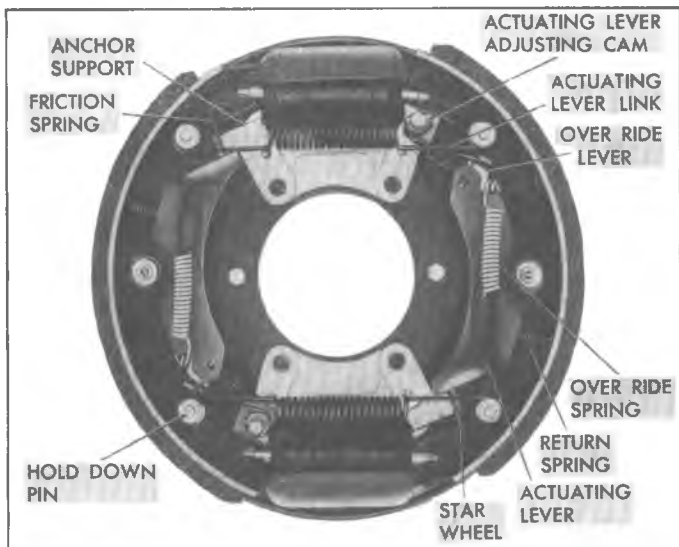

Fig. 75--Rear Brake--Used with RPO H-22

lever and hold the lever away from the star wheel. Using a brake adjusting tool, back off the star wheel.

## Brake Drums, Shoes and Linings

### Removal

1. Raise the vehicle on a hoist.
2. Retract self adjusters if necessary and remove brake drums.
3. Using Tool J-22348, remove the brake shoe pull back springs (fig. 76).
4. Loosen the actuating lever cam cap screw and while holding the star wheel end of the actuating lever past the star wheel, remove the cap screw and cam.
5. Remove the brake shoe hold down springs and pins by compressing the spring with Tool J-22348 and, at the same time, pushing the pin back through the flange plate toward the tool. Then, keeping the spring compressed, remove the lock from the pin with a magnet (fig. 77).
6. Lift off the brake shoe and self adjuster as an assembly.
7. The self adjuster can now be removed from the brake shoe by removing the hold down spring and pin.

**NOTE:** The actuating lever, override lever and spring are an assembly. It is recommended that they not be disassembled for service purposes unless they are broken. It is much easier to assemble and disassemble the brakes leaving them intact.

8. Thread the adjusting screw out of the anchor support and remove and discard the friction spring.
9. Clean all dirt out of brake drum. Inspect drums for roughness, scoring or out-of-round. Replace or recondition drums as necessary.

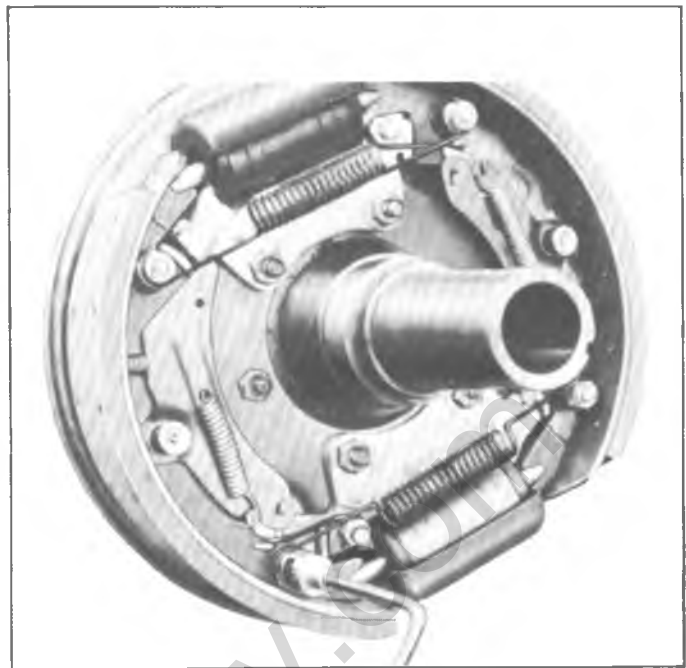

Fig. 76--Removing Pull Pack Spring with Tool J-22348

**NOTE:** See Section on "BRAKE DRUMS".

10. Carefully pull lower edges of wheel cylinder boots away from cylinders. If brake fluid flows out, overhaul of the wheel cylinders is necessary.

**NOTE:** A slight amount of fluid is nearly always present and acts as a lubricant for the piston.

11. Inspect flange plate for oil leakage past axle shaft oil seals. Install seals if necessary.
12. Check all flange plate attaching bolts to make sure they are tight (150 ft. lbs. torque). Clean all dirt

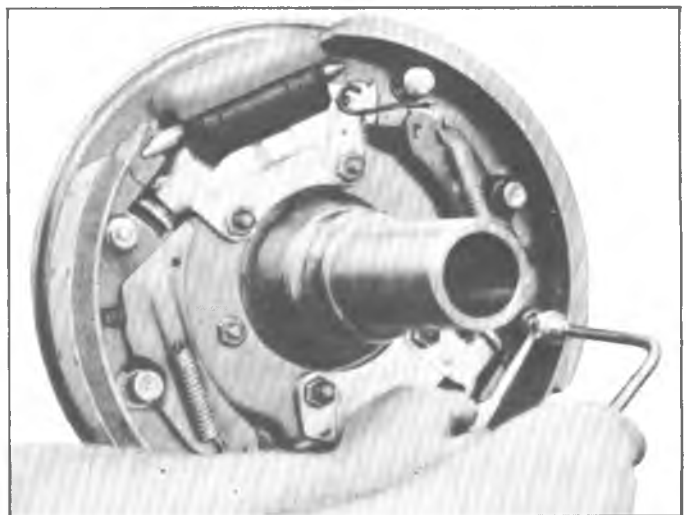

Fig. 77--Removing Hold Down Pins Using J-22348

and rust from shoe contact faces on flange plate using emery cloth.

13. Thoroughly clean adjusting screws and threads in the anchor brackets.

#### Installation

1. Put a light film of Delco Brake Lube #5450032 (or equivalent) on shoe bearing surfaces of brake flange plate and on threads of adjusting screw.
2. Thread adjusting screw completely into anchor bracket without friction spring to be sure threads are clean and screw turns easily. Then remove screw, position a new friction spring on screw and reinstall in anchor bracket.

**CAUTION:** See "Caution" on Page 1 of this section.

3. Assemble self adjuster assembly to brake shoe and position actuating lever link on override lever.
4. Position hold down pins in flange plate.
5. Install brake shoe and self adjuster assemblies onto hold down pins, indexing ends of shoes with wheel cylinder push rods and legs of friction springs.

**NOTE:** Make sure the toe of the shoe is against the adjusting screw (fig. 78).

6. Install cup, spring and retainer on end of hold down pin. Using Tool J-22348, compress the spring. With spring compressed, push the hold down pin back through the flange plate toward the tool and install the lock on the pin.
7. Using Tool J-22348, install brake shoe return springs.
8. Holding the star wheel end of the actuating lever as far as possible past the star wheel, position the

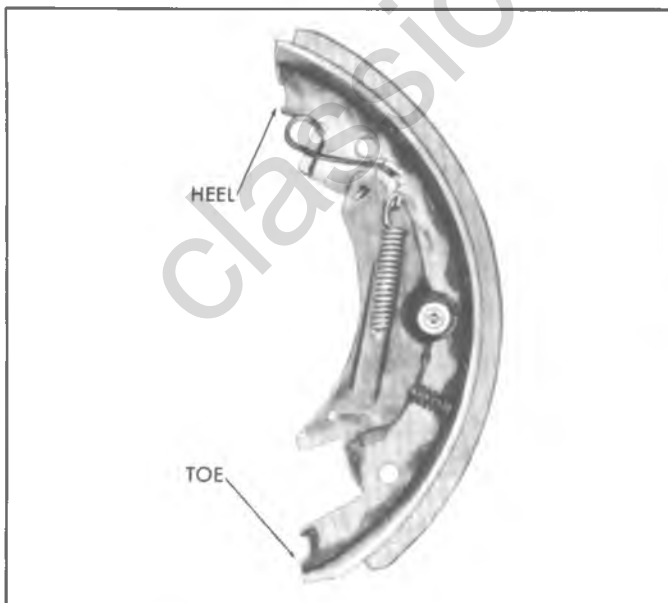

Fig. 78--Brake Shoe and Self Adjuster Assembly



Fig. 79--Measuring Points for Shoe Centering

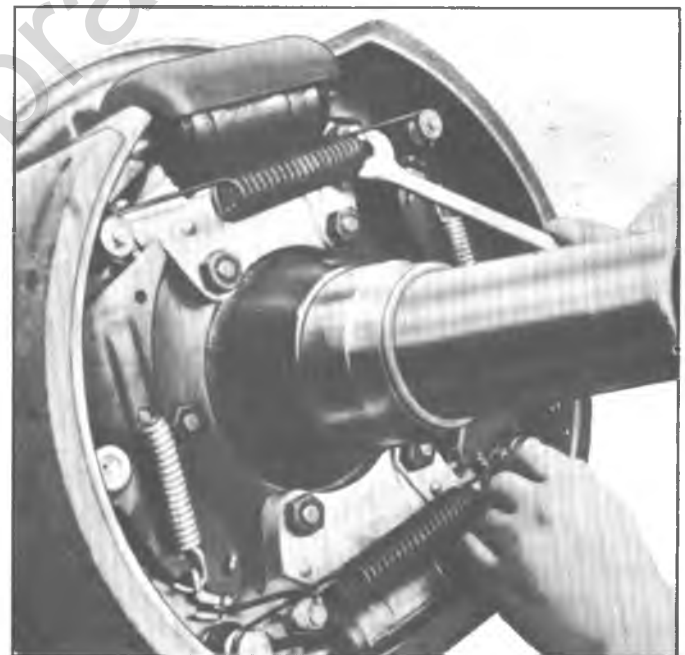

Fig. 80--Positioning Actuator Lever

adjusting lever cam into the actuating lever link and assemble with cap screw.

9. Check the brake shoes for being centered by measuring the distance from the lining surface to the edge of the flange plate at the points shown in Figure 79. To center the shoes, tap the upper or lower end of the shoes with a plastic mallet until the distances at each end become equal.

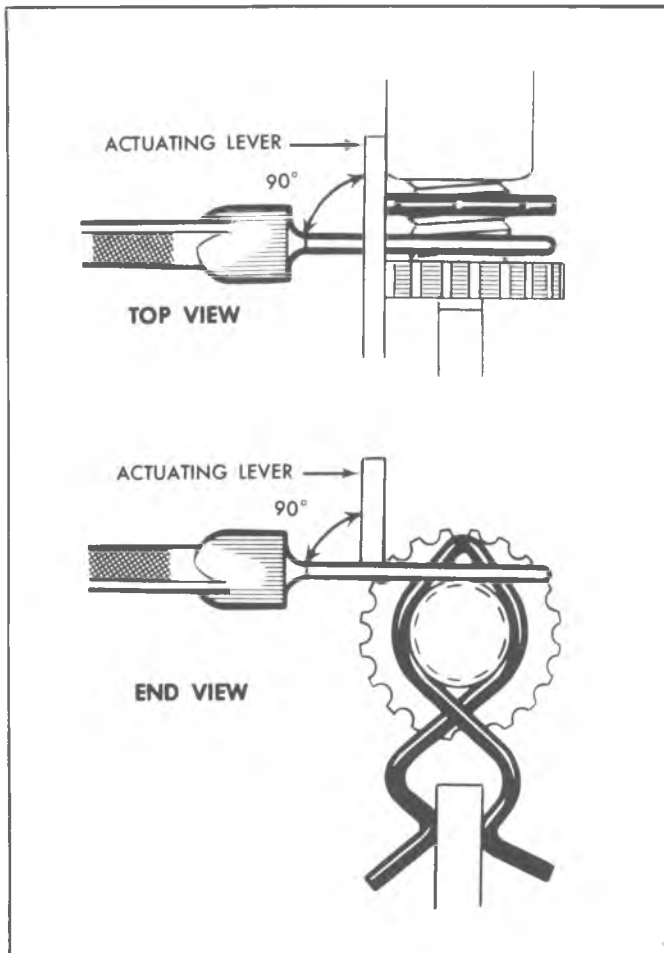

Fig. 81--Pull Gauge Positioning for Correct Actuator Lever Adjustment

10. Locate the adjusting lever .020" to .039" above the outside diameter of the adjusting screw thread by loosening the cap screw and turning the adjusting cam.

NOTE: To determine .020" to .039", turn the adjusting screw 2 full turns out from the fully retracted position. Hold a .060" plug gauge (from J-9789-01 Universal Carburetor Gauge Set) at a 90° angle with the star wheel edge of the actuating lever. Turn the adjusting cam until the actuating lever and threaded area on the adjusting screw just touch the gauge (figs. 80 and 81).

11. Secure the adjusting cam cap screw and retract the adjusting screw.
12. Install brake drums and wheels and remove vehicle from jack stands.
13. Adjust the brakes by making several forward and reverse stops until a satisfactory brake pedal height results.

## DIAGNOSIS

### INSPECTION

At a reasonably frequent interval, the brake system should be inspected for pedal reserve, which is the clearance between the pedal pad and the floorpan. Inspection should be made with the brake pedal firmly depressed while the brakes are cold. Pedal reserve on manual brake vehicles is usually not less than 2-1/4". On power brake-equipped vehicles, the pedal reserve is usually not less than 1-1/2".

NOTE: Heat generated by high speed stops will expand brake drums and increase shoe clearance, thereby permitting the pedal pad to go closer to the floorpan than when the brakes are cold.

Brake shoe linings should not be permitted to wear down until rivets or shoes contact drums because the drums could be scored. As the vehicle mileage approaches the point where relining may be required, it is advisable to remove one or more drums for inspection of linings in order to avoid the possibility of damaging brake drums.

### PRELIMINARY CHECKS

#### External Conditions That Affect Performance

In addition to previously mentioned conditions, the following external conditions may affect brake performance and should be corrected before work is done on the brake mechanism.

#### Tires

Tires having unequal contact and grip on the road could cause unequal braking. Tires should be equally inflated and tread pattern of right and left tires should be approximately equal.

#### Loading

When the vehicle has unequal loading, the most heavily loaded wheels require more braking power than others.

#### Shock Absorbers

Faulty shock absorbers that permit bouncing of the vehicle on quick stops may give the erroneous impression that brakes are too severe.

## General Checks

**NOTE:** If a damaged component or malfunction is discovered while making any of the following brake system checks, repairs must be made before attempting to continue with additional diagnosis.

1. Inspect for excessive tire tread wear and indications of front suspension misalignment. Check tire pressures and for improperly adjusted or worn wheel bearings. Any of these conditions can result in an improper diagnosis.
2. Check master cylinder fluid level. If low, refill to the proper level, pressurize the system, and make an inspection of the entire brake system for leakage. Wheel cylinder leakage can frequently be detected by the presence of brake fluid on the inboard side of the wheel and tire.
3. Power Brake:
  - a. With transmission in Park, stop the engine, and exhaust all vacuum in the system by depressing the pedal several times.
  - b. Depress the brake pedal and hold it in the apply position for one minute with approximately 20 lbs. pedal force. If the pedal gradually falls away or the brake warning light comes on, it is an indication that the hydraulic system is leaking or that there is a malfunction in the master cylinder. Check all tubing, hoses, wheel cylinders, calipers and connections for leakage before replacing the master cylinder.
  - c. If the brake pedal feels spongy, it is an indication of air in the hydraulic system. Bleed the air from the system and recheck the pedal feel.

**NOTE:** Steps (b) and (c) may also be used to check for leakage or the presence of air in a non-vacuum powered brake system.

  - d. Depress the brake pedal and start the engine. If the vacuum system is operating, the brake pedal will tend to fall away when the engine starts and less pedal pressure will be needed to hold it in the applied position. If no action is felt when the engine starts, the vacuum system is inoperative.

## ROAD TESTING

**CAUTION:** A road test should be made only when the operator is sure that the brakes will stop the vehicle.

Road tests are necessary to check brakes for safe, quiet performance. Preliminary inspection should be made in the shop as outlined in the preceding paragraphs. The following tests will aid in the evaluation of brake performance and the need for service. They should be conducted on dry, clean, reasonably smooth and level roadway. Use care not to induce fade unintentionally

with continuous applications during test. Refer to the Troubleshooting Chart for causes and remedies for trouble which may be discovered during testing.

**WARNING:** Before driving any vehicle, push the brake pedal to make sure it will not bottom. Next, make a series of slow speed stops to determine if the brakes are safe for driving.

### Low Speed Test for Effectiveness, Pulls and Noise

Make light and medium stops at from 10 to 15 MPH. Bring the vehicle to a complete stop each time. Observe the effort required to make each stop. Is it too light (grabby) satisfactory or too hard? Check for pulls. Unequal front brakes will cause pulls in the direction of the brake doing the most work. Unequal rear brakes may not cause noticeable pulling during low speed stops. Check for noise. Open the windows and turn off all accessories and listen to determine the type of noise and the wheel from which it is coming.

**NOTE:** Driving along a wall when applying brakes will make noises more audible.

### High Speed Test for Roughness or Pulsations

Make light stops from 60 MPH or maximum legal speed. Check for roughness or pulsations by pedal feel and vehicle vibration.

### High Speed Test for Effectiveness, Pulls and Noise

Make hard stops (just short of skid) from 60 MPH. Bring the vehicle to a complete stop each time. Do not repeat stops within two miles of each other to avoid high brake temperatures. Observe the effort required to make each stop. Is it too light (grabby), satisfactory or too hard? Check for pulls. Unequal brakes will cause pulls in the direction of the brake doing the most work. Check for noise to determine the type and the wheel from which it is coming.

### High Speed Test for Fade

**NOTE:** Fade is a temporary reduction of brake effectiveness resulting from heat.

Make three hard stops (just short of skid) from 60 MPH at 1/2 mile increments or just as fast as possible. Check for pulls and observe the effort required to make the stops. These should be made without strenuous effort. Check pedal reserve after each stop.

### High Speed Test for Delayed Fade

After making previous fade test, let the vehicle stand for 10 minutes. Then, accelerate quickly to 60 MPH and make one hard stop, just short of a skid. Check for pulls and observe the effort required to make the stop. Check pedal reserve.

## DIAGNOSIS—DRUM BRAKES

## LOW PEDAL OR PEDAL GOES TO TOE BOARD

Probable Cause	Remedy
1. Excessive clearance between linings and drum.	1. Adjust brakes.
2. Automatic adjusters not working.	2. Make forward and reverse stops; if pedal stays low, repair faulty adjusters.
3. Leaking conduits.	3. Repair or replace faulty parts.
4. Leaking wheel cylinder.	4. Overhaul wheel cylinder, as outlined previously in this section.
5. Leaking master cylinder.	5. Overhaul master cylinder as outlined previously in this section.
6. Air in system.	6. Bleed system.
7. Plugged master cylinder filler cap.	7. Clean filler cap vent holes; bleed system.
8. Improper brake fluid.	8. Flush system. Replace all rubber parts in the system. Refill with GM Hydraulic Brake Fluid Supreme No. 11 (or Dot-3 brake fluid).
9. Low fluid level.	9. Fill reservoir with GM Hydraulic Brake Fluid Supreme No. 11 (or Dot-3 brake fluid); bleed system.

## SPRINGY, SPONGY PEDAL

Probable Cause	Remedy
1. Air trapped in hydraulic system.	1. Remove air by bleeding.
2. Improper brake fluid.	2. Flush system. Replace all rubber parts in the system. Refill with GM Hydraulic Brake Fluid Supreme No. 11 (or Dot-3 brake fluid).
3. Improper lining thickness or location.	3. Install new lining or replace shoe and lining.
4. Drums worn too thin.	4. Replace drums.
5. Master cylinder filler vent clogged.	5. Clean vent or replace cap; bleed brakes.

## EXCESSIVE PEDAL PRESSURE REQUIRED TO STOP CAR

Probable Cause	Remedy
1. Brake adjustment not correct.	1. Adjust the brakes.
2. Incorrect lining.	2. Install new linings or replace shoe and linings.
3. Grease or fluid soaked lining.	3. Repair grease seal or wheel cylinder. Install new linings.
4. Improper fluid.	4. Flush out system. Replace all rubber parts in the system. Refill with GM Hydraulic Brake Fluid Supreme No. 11 (or Dot-3 brake fluid); bleed system.
5. Frozen master or wheel cylinder pistons.	5. Overhaul master or wheel cylinders as outlined previously in this section.
6. Brake pedal binding on shaft.	6. Lubricate with Delco Brake Lube #5450032 (or equivalent).

## DIAGNOSIS—DRUM BRAKES

### EXCESSIVE PEDAL PRESSURE REQUIRED TO STOP (CONT.)

Probable Cause	Remedy
7. Glazed linings.	7. Sand surface of linings.
8. Bellmouthed, barrel-shaped or scored drums.	8. Replace or resurface drums in left and right hand pairs.

### LIGHT PEDAL PRESSURE—BRAKES TOO SEVERE

Probable Cause	Remedy
1. Brake adjustment not correct.	1. Adjust the brakes.
2. Loose flange plate on front axle.	2. Tighten plates.
3. A small amount of grease or fluid on linings.	3. Replace the linings or shoe and linings.
4. Charred linings.	4. Replace the linings or shoe and linings.
5. Incorrect lining.	5. Install new linings or shoe and linings.
6. Wheel bearings loose.	6. Adjust wheel bearings.
7. Lining loose on shoe.	7. Replace lining or shoe and lining.
8. Excessive dust and dirt in drums.	8. Clean and sand drums and linings.
9. Bellmouthed, barrel-shaped or scored drums.	9. Turn drums in pairs or replace.
10. Loose anchor pin.	10. Retorque; replace if bent or damaged.
11. Bent shoes.	11. Replace shoe and lining assembly.

### BRAKE PEDAL TRAVEL DECREASING

Probable Cause	Remedy
1. Master cylinder compensating port plugged.	1. Open, use air or .015 wire. Remove any burr in bore.
2. Swollen cup in master cylinder.	2. Replace rubber parts. Flush system. Refill with GM Hydraulic Brake Fluid Supreme No. 11 (or Dot-3 brake fluid.)
3. Master cylinder piston not returning.	3. Overhaul master cylinder as outlined previously in this section.
4. Weak shoe retracting springs.	4. Replace springs.
5. Wheel cylinder pistons sticking.	5. Overhaul wheel cylinder as outlined previously in this section.

### PULSATING BRAKE PEDAL

Probable Cause	Remedy
1. Drums out-of-round.	1. Refinish drums.
2. Loose brake drum on hub.	2. Replace drum.
3. Worn or loose wheel bearings.	3. Replace or adjust.
4. Bent rear axle.	4. Replace axle.
5. Drums not concentric with pilot.	5. Refinish to be concentric with pilot (small diameter inside of bolt circle).

## DIAGNOSIS—DRUM BRAKES

## \*BRAKES FADE

Probable Cause	Remedy
1. Incorrect lining.	1. Replace with new lining or shoe and lining assembly.
2. Thin drum.	2. Replace drums.
3. Dragging brakes.	3. Adjust or correct cause.

\*Fade is a temporary reduction of brake effectiveness resulting from heat.

## ALL BRAKES DRAG WHEN ADJUSTMENT IS KNOWN TO BE CORRECT

Probable Cause	Remedy
1. Pedal does not return to stop.	1. Lubricate the pedal with Delco Brake Lube #5450032 (or equivalent).
2. Improper fluid.	2. Replace rubber parts. Flush system and refill with GM Hydraulic Brake Fluid Supreme No. 11 (or Dot-3 brake fluid).
3. Compensating or bypass port of master cylinder closed.	3. Open with compressed air.
4. Use of inferior rubber parts.	4. Overhaul wheel and/or master cylinder using new Delco kits (or equivalent).
5. Brakes do not pull back with hydraulic system disconnected.	5. Check pull back springs; replace if required.

## ONE WHEEL DRAGS

Probable Cause	Remedy
1. Weak or broken shoe retracting springs.	1. Replace the defective brake shoe springs and lubricate the brake shoe ledges with Delco Brake Lube #5450032 (or equivalent).
2. Brake shoe to drum clearance too small or the brake shoe eccentric is not adjusted properly.	2. Adjust.
3. Loose wheel bearings.	3. Adjust wheel bearings.
4. Wheel cylinder pistons cups swollen and distorted or the pistons stuck.	4. Overhaul cylinders as outlined previously in this section.
5. Pistons sticking in wheel cylinder.	5. Clean or replace pistons; clean cylinder bore.
6. Drum out-of-round.	6. Grind or turn both front or rear drums.
7. Obstruction in line.	7. Clean out or replace.
8. Loose anchor pin.	8. Adjust and tighten lock nut.
9. Distorted shoe.	9. Replace
10. Defective lining.	10. Replace with new lining or shoe and lining assembly.



## DIAGNOSIS—DRUM BRAKES

## REAR BRAKES DRAG

Probable Cause	Remedy
1. Maladjustment.	1. Adjust brake shoes and parking brake mechanism.
2. Parking brake cables frozen.	2. Lubricate with Delco Brake Lube #5450032 (or equivalent).

## PULLS TO ONE SIDE

Probable Cause	Remedy
1. Grease or fluid soaked lining.	1. Replace with new linings or shoe and lining assemblies.
2. Adjustment not correct.	2. Adjust the brakes.
3. Loose wheel bearings, loose flange plate on rear axle or front axle or loose spring bolts.	3. Adjust the wheel bearing, tighten the flange plate on the rear and front axles and tighten spring bolts.
4. Linings not of specified kind or primary and secondary shoes reversed.	4. Install new linings or shoe and lining assemblies.
5. Tires not properly inflated or unequal wear of tread. Different tread non-skid design.	5. Inflate the tires to recommended pressures. Rearrange the tires so that a pair of non-skid tread surfaces of similar design and equal wear will be installed on the front wheels, and another pair with like tread will be installed on the rear wheels.
6. Linings charred.	6. Replace with new lining or shoe and lining assemblies.
7. Water, mud, etc., in brakes.	7. Remove any foreign material from all of the brake parts and the inside of the drums. Lubricate the shoe ledges and the rear brake cable ramps with Delco Brake Lube #5450032 (or equivalent).
8. Wheel cylinder sticking.	8. Overhaul or replace wheel cylinder.
9. Weak or broken retracting springs.	9. Check springs—replace bent, open-coiled or cracked springs.
10. Out-of-round drums.	10. Resurface or replace drums in left and right hand pairs.
11. Brake dragging.	11. Check for loose lining. Adjust.
12. Weak chassis springs or loose "U" bolts.	12. Replace springs or tighten "U" bolts.
13. Loose steering.	13. Repair and adjust.
14. Unequal camber.	14. Adjust to specifications.
15. Clogged or crimped hydraulic line.	15. Repair or replace line.
16. Wheel cylinder size different on opposite sides.	16. Replace with correct cylinders.
17. Loose king pin or bushings.	17. Replace king pins or bushings.
18. Bad drum.	18. Refinish drums in pairs.

## DIAGNOSIS—DRUM BRAKES

## ONE WHEEL LOCKS

Probable Cause	Remedy
1. Gummy lining.	1. Replace the linings.
2. Tire tread slick.	2. Match up tire treads from side to side.

## WET WEATHER: BRAKES GRAB OR WON'T HOLD

Probable Cause	Remedy
1. Linings too sensitive to water.	1. Replace the linings.
2. Dirty brakes.	2. Clean.
3. Bent flange plate - opening.	3. Replace flange plate.
4. Scored drums.	4. Grind or turn in pairs.

## BRAKES SQUEAK

Probable Cause	Remedy
1. Flange plate bent or shoes twisted.	1. Replace damaged parts.
2. Lining rivets loose or lining not held tightly against the shoe at the ends.	2. Replace rivets and/or tighten lining by re-riveting.
3. Drums not square or distorted.	3. Turn or grind or replace drums.
4. Shoes scraping on flange plate ledges.	4. Apply Delco Brake Lube #5450032 (or equivalent) to ledges. Replace with new shoe and linings, if distorted.
5. Weak or broken hold down springs.	5. Replace defective parts.
6. Loose wheel bearings.	6. Tighten to proper setting.
7. Loose flange plate, anchor, drum wheel cylinder.	7. Tighten
8. Linings located wrong on shoes.	8. Install linings correctly.
9. Brake drum silencer spring missing or too weak.	9. Install new spring.
	NOTE: Most models do not incorporate silencer springs.

## DIAGNOSIS—DRUM BRAKES

## BRAKES CHATTER

Probable Cause	Remedy
1. Incorrect lining to drum clearance.	1. Readjust to recommended clearances.
2. Loose flange plate.	2. Tighten securely.
3. Grease, fluid, road dust on lining.	3. Clean out dust; replace grease and fluid soaked linings.
4. Weak or broken retractor spring.	4. Replace.
5. Loose wheel bearings.	5. Readjust.
6. Drums out-of-round.	6. Grind or turn drums in pairs.
7. Cocked or distorted shoes.	7. Straighten or replace.
8. Tapered or barrel-shaped drums.	8. Grind or turn in pairs.
9. Drums poorly finished.	9. Refinish.

## SHOE CLICK

Probable Cause	Remedy
1. Shoes lift off flange plate and snap back.	1. Change drums side to side or grind drums (in pairs).
2. Hold down springs weak.	2. Replace springs.
3. Shoe bent.	3. Replace shoe and lining assemblies.
4. Grooves in flange plate pads.	4. Grind - lubricate with Delco Brake Lube #5450032 (or equivalent).

## SNAPPING NOISE IN FRONT END

Probable Cause	Remedy
1. Grooved flange plate pads.	1. Grind pads or replace flange plate.
2. Lack of lubrication on moving parts.	2. Lubricate all rubbing points with Delco Brake Lube #5450032 (or equivalent).
3. Loose drums or flange plates.	3. Tighten.
4. Loose or worn front end parts.	4. Tighten or replace defective parts.

## THUMPING NOISE WHEN BRAKES ARE APPLIED

Probable Cause	Remedy
1. Too much clearance between shoes and anchors.	1. Adjust.
2. Retractor springs unequal - weak.	2. Replace springs.

**DIAGNOSIS—DRUM BRAKES**

**GRINDING NOISE**

Probable Cause	Remedy
1. Shoe hits drum.	1. Switch drums or grind drums.
2. Bent shoe web.	2. Replace shoe and lining assemblies.
3. Foreign material in lining.	3. Remove.
4. Rivets or shoe rubbing drum.	4. Reline - refinish drums, if scored.
5. Lining charred.	5. Replace the linings or shoe and lining assemblies.
6. Rough drum surface.	6. Refinish drums.

**DIAGNOSIS—DISC BRAKES**

**PULLS**

Probable Cause	Remedy
1. Incorrect tire pressures.	1. Inflate evenly on both sides to the recommended pressures. (See owner's manual.)
2. Front end out of line.	2. Check and align to manufacturer's specifications.
3. Unmatched tires on same axle.	3. Tires with approximately the same amount of tread should be used on the same axle.
4. Restricted brake tubes or hoses.	4. Check for soft hoses and damaged lines. Replace with new hoses and new double-walled steel brake tubing.
5. Malfunctioning caliper assembly.	5. Check for stuck or sluggish pistons.
6. Defective or damaged shoe & lining (grease or brake fluid on lining or bent shoe).	6. Install new shoe and lining on complete axle.
7. Malfunctioning rear brakes.	7. Check for inoperative automatic adjusting mechanism, defective lining (grease or brake fluid on lining) or defective wheel cylinders. Repair as necessary.
8. Loose suspension parts.	8. Check all suspension mountings.
9. Loose calipers.	9. Check and torque all bolts to specifications.

**BRAKE ROUGHNESS OR CHATTER (PEDAL PULSATES)**

Probable Cause	Remedy
1. Excessive lateral runout.	1. Check per instructions and resurface the rotor, if not within specifications.
2. Parallelism not within specifications.	2. Check per instructions and resurface the rotor, if not within specifications.
3. Wheel bearings not adjusted correctly.	3. Adjust wheel bearings to correct specifications.
4. Circumferential thickness variation not within specifications.	4. Resurface the rotor if not within specifications.

## DIAGNOSIS—DISC BRAKES

## BRAKE ROUGHNESS, ETC. (CONT.)

Probable Cause	Remedy
4. Rear drums out-of-round.	4. Check runout and if not within specifications, turn the drums. (Not over maximum of .060 on the diameter.)
5. Shoe reversed (steel against iron).	5. Replace rotor and shoe and lining.

## EXCESSIVE PEDAL EFFORT

Probable Cause	Remedy
1. Malfunctioning power brake.	1. Check power brake and repair if necessary.
2. Partial system failure (dual master cylinder).	2. Check front and rear brake system and repair if necessary. Also check brake warning light if a failed system is found and light did not function.
3. Excessively worn shoe and lining.	3. Check and replace in axle sets.
4. Pistons in calipers stuck or sluggish.	4. Remove calipers and rebuild.
5. Fading brakes due to incorrect lining.	5. Remove and replace with original equipment.

## EXCESSIVE PEDAL TRAVEL

Probable Cause	Remedy
1. Partial brake system failure (with dual system master cylinders).	1. Check both front and rear systems for a failure and repair. Also check warning light, if vehicle is so equipped. It should have indicated a failure.
2. Insufficient fluid due to leak in system.	2. Repair leak. Fill reservoirs with GM Hydraulic Brake Fluid Supreme No. 11 (or Dot-3 brake fluid).
3. Incorrect master cylinder push rod adjustment.	3. Adjust clevis where possible.
4. Air trapped in system.	4. Bleed system.
5. Rear brake not adjusting properly.	5. Adjust rear brakes and repair auto adjusters.
6. Bent shoe and lining.	6. Replace axle set of shoe and lining.

## DRAGGING BRAKES

(A very light drag is present in all disc brakes immediately after pedal is released)

Probable Cause	Remedy
1. Master cylinder pistons not returning correctly.	1. With reservoir cover off, check for fluid spurt at bypass holes as pedal is depressed. Adjust push rod, if necessary or rebuild master cylinder.
2. Restricted brake tubes or hoses.	2. Check for soft hoses or damaged tubes and replace with new hoses and new double-walled steel brake tubing.

## DIAGNOSIS—DISC BRAKES

## DRAGGING BRAKES (CONT.)

Probable Cause	Remedy
3. Incorrect parking brake adjustment on rear brakes.	3. Check and readjust to correct specifications.
4. Metering valve installed incorrectly.	4. Port marked "inlet" goes to master cylinder, Port marked "outlet" goes to disc calipers.
5. Check valve installed in outlet to front disc brakes.	5. Check outlet hole and remove check valve, if line is connected to disc brake calipers.

## GRABBING OR UNEVEN BRAKING ACTION

Probable Cause	Remedy
1. All conditions listed under "PULLS".	1. See "PULLS".
2. Malfunction of metering valve or proportioning valve.	2. Replace and bleed system.
3. Malfunction of power brake unit.	3. Check operation and repair, if necessary.
4. Binding brake pedal mechanism.	4. Check and lubricate with Delco Brake Lube #5450032 (or equivalent) if necessary.
5. Metering valve not holding off front brake application.	5. Replace metering valve and bleed system. If vehicle is not equipped with metering valve, check other causes.

## REAR DRUM BRAKES SKIDDING PREMATURELY UNDER HARD BRAKE APPLICATION

Probable Cause	Remedy
1. Proportioning valve not controlling rear line pressure to prevent rear wheel lockup on hard brake applications.	1. Replace proportioning valve and bleed system. If vehicle is not equipped with proportioning valve, check other causes listed under "PULLS" or "GRABBING OR UNEVEN BRAKING ACTION".

# VACUUM POWER BRAKES

## INDEX

General Description .....	5-57
Theory of Operation.....	5-57
Maintenance and Adjustments .....	5-63
Inspection .....	5-63
Lubrication.....	5-64
Bleeding.....	5-64
Air Cleaner Service.....	5-64
Component Part Replacement.....	5-64
Power Brake Unit.....	5-64
Diagnosis.....	5-65

## GENERAL DESCRIPTION

The Power brake Unit is a self-contained hydraulic and vacuum unit, utilizing manifold vacuum and atmospheric pressure for its power.

This unit permits the use of a low brake pedal as well as

less pedal effort than is required with the conventional (nonpower) hydraulic brake system. The unit is mounted on the engine side of the dash panel and directly connected to the brake pedal.

## THEORY OF OPERATION

A power brake is used with the brake system to reduce the braking effort required by the driver. A combined vacuum and hydraulic unit, which utilizes engine manifold vacuum and atmospheric pressure, is used to provide power assisted application of vehicle brakes.

The unit is used in conjunction with a conventional brake system. From the master cylinder connection outward to the wheel units, there is no other change in the brake system.

In addition to the master cylinder connections, the unit requires a vacuum connection to the engine intake manifold (through a vacuum check valve) and a mechanical connection to the brake pedal. The unit is self-contained.

The vacuum power unit contains the power piston assembly, which houses the control valve and reaction mechanism, and the power piston return spring. The control valve is composed of the air valve (valve plunger), the floating control valve assembly, and the push rod. The reaction mechanism consists of a hydraulic piston reaction plate and a series of levers. An air filter, air silencer, and filter retainer are assembled around the valve operating rod filling the cavity inside the hub of the power piston. The push rod or valve operating rod, which operates the air valve, projects out of the end of the power unit housing through a rubber dust guard. A vacuum check valve assembly is mounted in the front housing assembly for connection to the vacuum source.

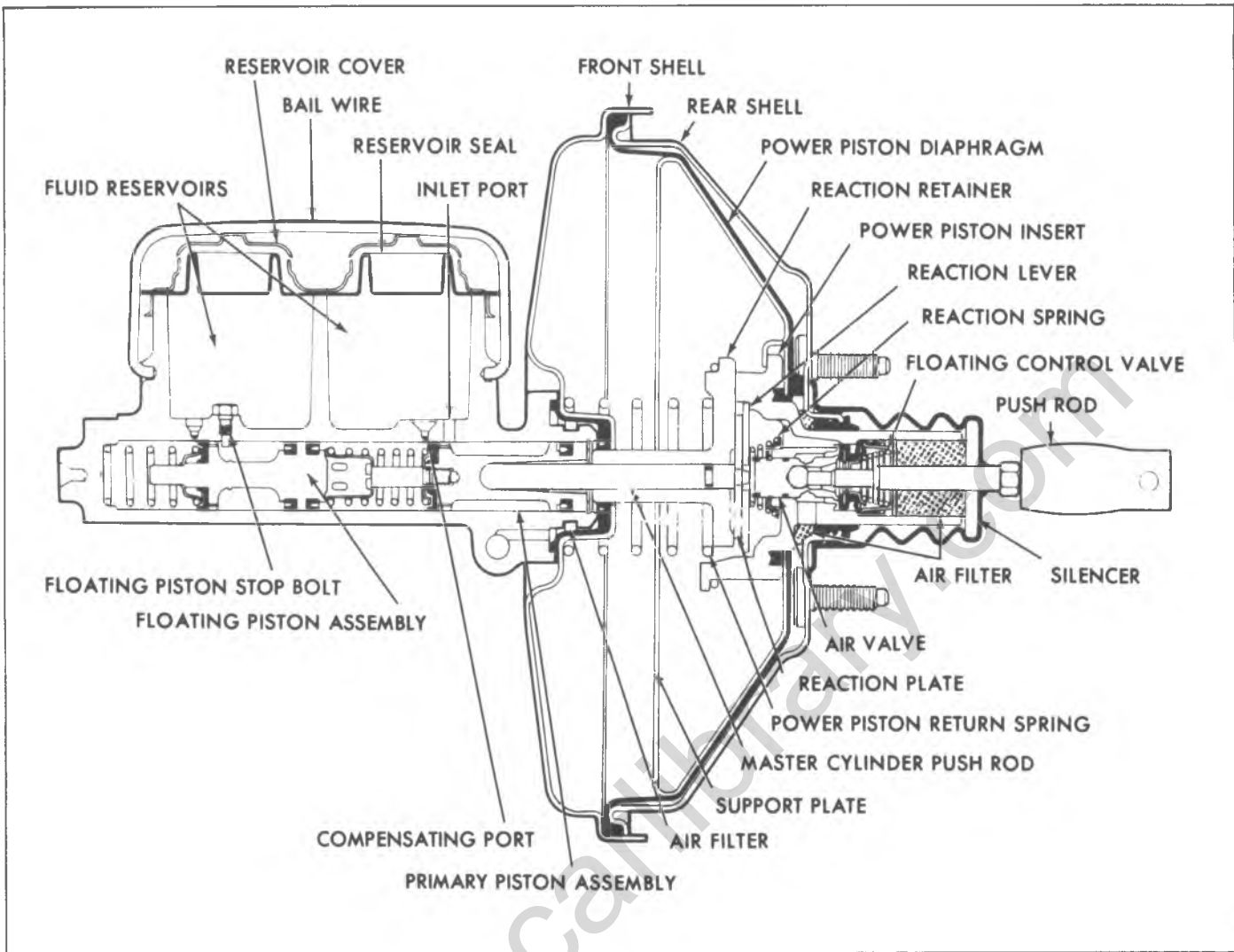

Fig. 82--Typical Power Unit - Released

**RELEASED (Figs. 82 and 83)**

At the released position the air valve is seated on the floating control valve. Air at atmospheric pressure, which enters through the filter element in the tube extension of the power piston, is shut off at the air valve. The floating control valve is held away from the valve seat in the power piston insert. Vacuum is present in the space on

both sides of the power piston. Any air in the system is drawn through a small passage in the power piston, over the valve seat in the power piston insert, and then through a passage in the power piston support plate into the space in front of the power piston. It is then drawn through the check valve and into the engine intake manifold.



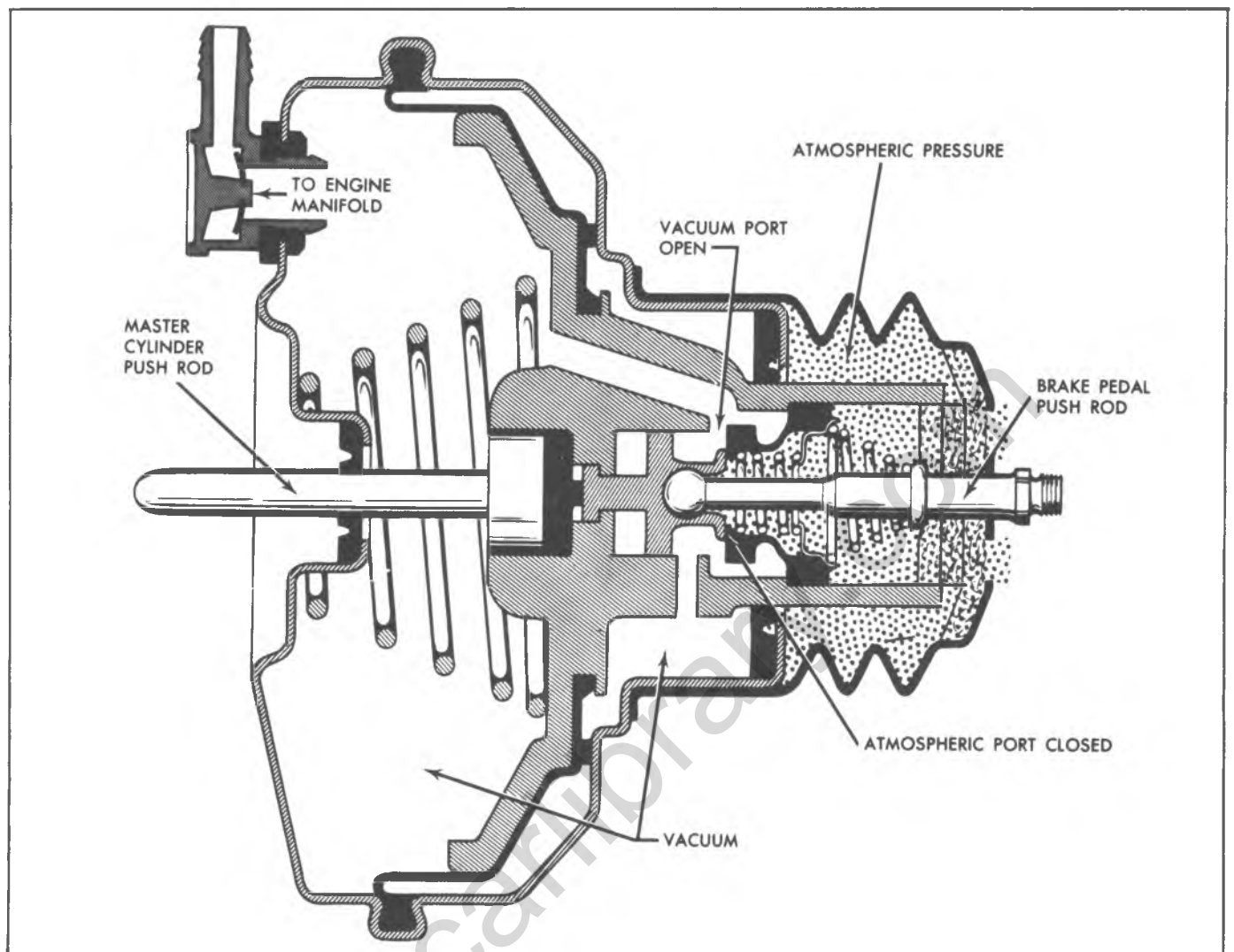

Fig. 83--Typical Circuit - Released

In this position there is vacuum on both sides of the power piston, and the power piston is held against the rear of the housing by the power piston return spring. At rest, the hydraulic reaction plate is held against the reaction retainer. The air valve spring holds the reaction levers against the hydraulic reaction plate and also holds the air valve against its stop in the tube of the power

piston. The floating control valve assembly is held against the air valve seat by the floating control valve spring.

With the power brake at released position, the master cylinder primary seals on both the rear (primary) piston and the floating (secondary) piston are back past the two compensating ports in the bore.

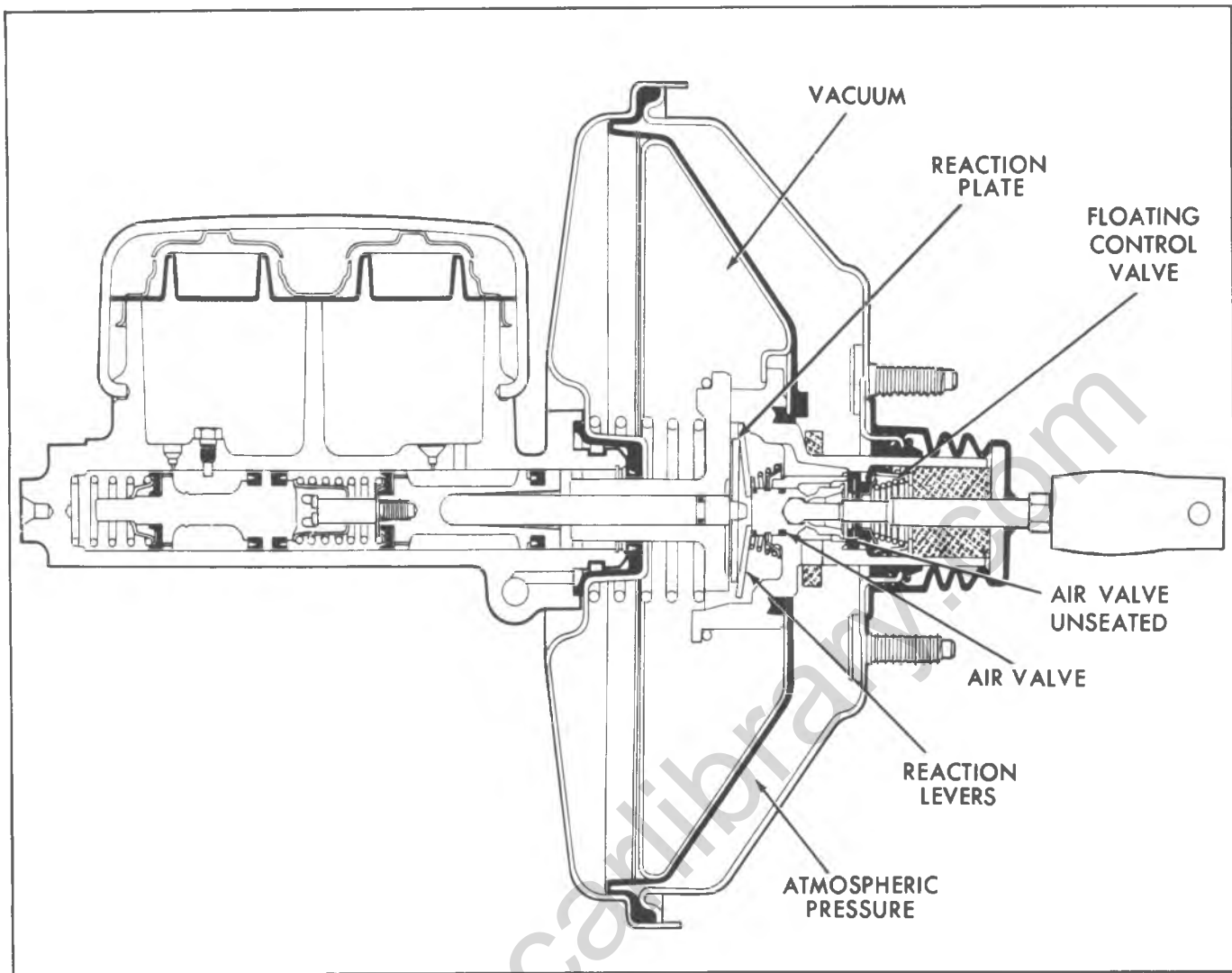

Fig. 84 - Typical Power Unit - Applying

### APPLYING (Figs. 84 and 85)

As the pedal is depressed, the valve operating rod (push rod) carries the air valve away from the floating control valve. The floating control valve will follow until it is in contact with the raised seat in the power piston insert. When this occurs, vacuum is shut off to the rear of the

power piston, and air under atmospheric pressure enters through the air filter and travels past the seat of the air valve and through a passage into the housing at the rear of the power piston. Since there is still vacuum on the front side of the power piston, the atmospheric air pressure at the rear of the piston will force the power piston to travel forward.

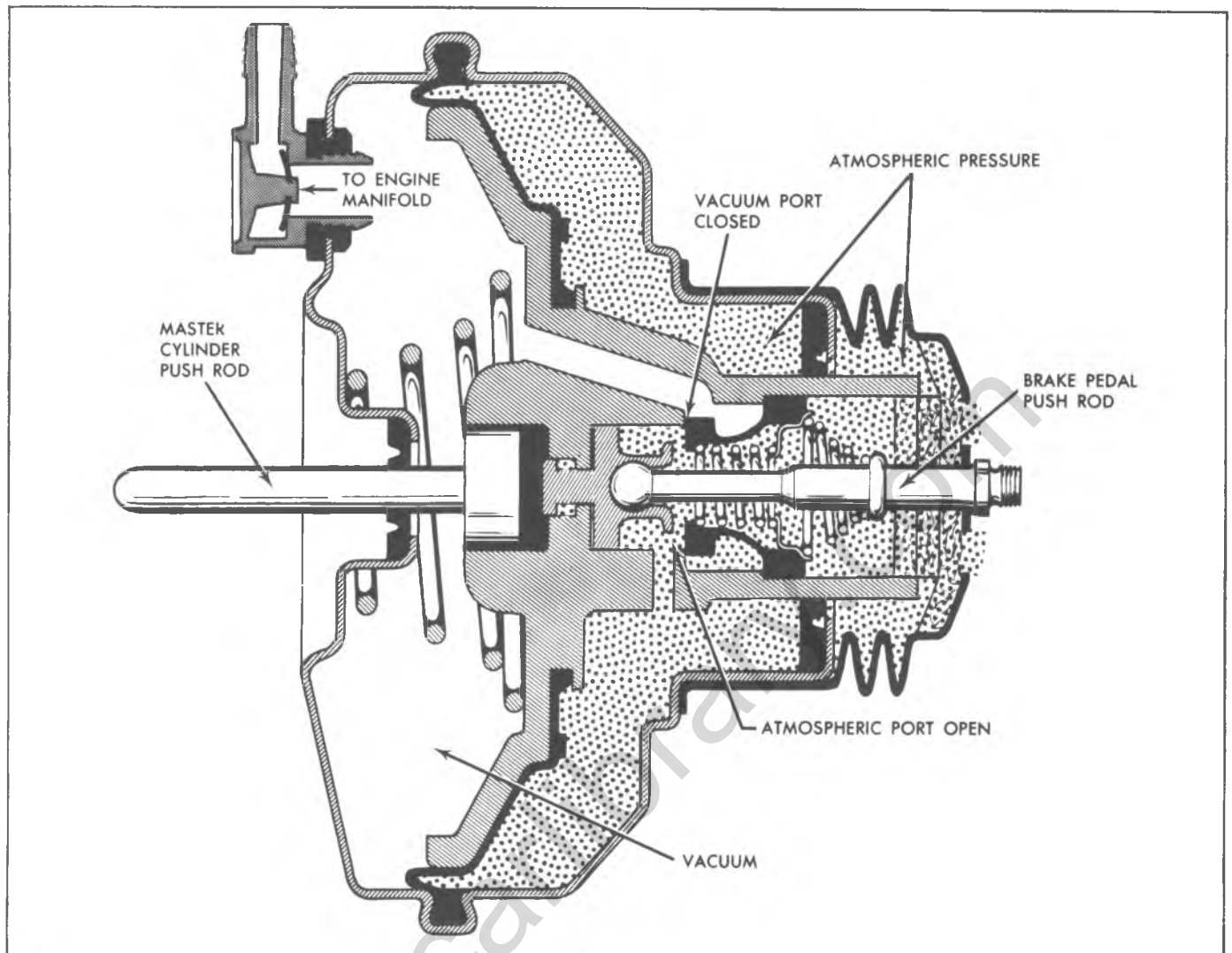

Fig. 85--Typical Circuit - Applying

As the power piston travels forward, the master cylinder piston rod carries the master cylinder primary piston further into the bore of the master cylinder. The force on the master cylinder primary piston spring forces the secondary piston to move forward. As the primary seal, on both the master cylinder primary and the secondary pistons pass the compensating ports in the bore, hydraulic pressure will build up in the lines to the front and rear brakes. As the pressure builds up on the end of

the master cylinder piston, the hydraulic reaction plate is moved off its seat on the power piston and presses against the reaction levers. The levers, in turn, swing about their pivots and bear against the end of the air valve operating rod assembly. In this manner approximately 30% of the load on the hydraulic master cylinder piston is transferred back through the reaction system to the brake pedal. This gives the operator a feel, which is proportional to the degree of brake application.

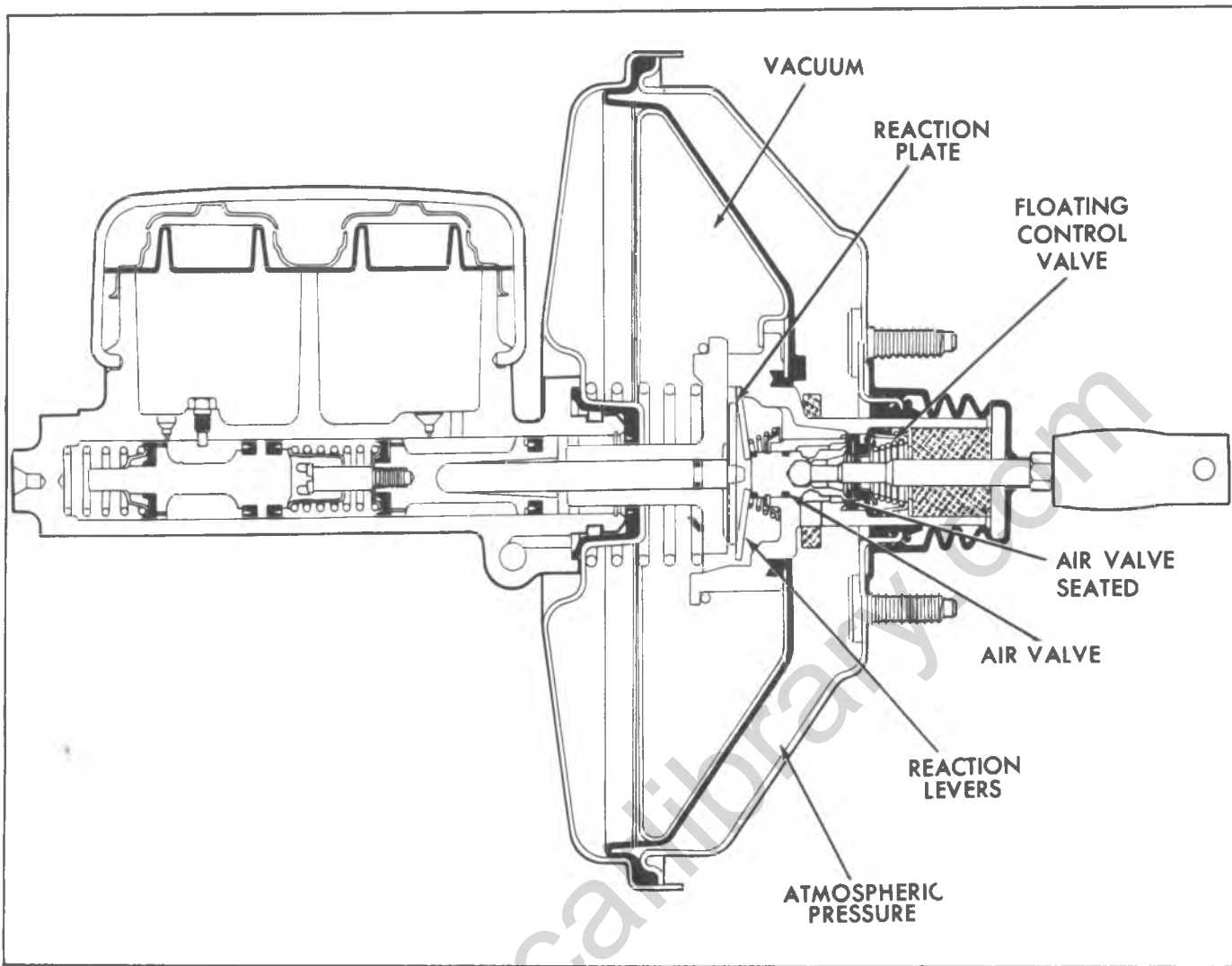

Fig. 86--Typical Power Unit - Holding

### HOLDING (Figs. 86 and 87)

When the desired pedal pressure is reached, the power piston moves forward until the floating control valve, which is still seated on the power piston, again seats on the air valve. The power piston will now remain stationary, until either pressure is applied or released at the brake pedal. As the pressure at the pedal is released, the air valve spring forces the air valve back to its stop on the power piston. As it returns, the air valve pushes the floating control valve off its seat on the power piston insert. The air valve seating on the floating control valve has shut off the outside air source. When it lifts the floating control valve from its seat on the power piston insert, it opens the space at the rear of the power piston to the vacuum source.

Since both sides of the power piston are now under vacuum, the power piston return spring will return the piston to its released position against the rear housing. As the power piston is returned, the master cylinder primary and secondary pistons move back, and the fluid from the wheel cylinders flows back into the master cylinder. If the brake pedal is released quickly, the master cylinder primary and secondary pistons immediately return to the released position. If the fluid in the lines cannot return as quickly as the pistons, this is compensated for by the flow of fluid from the space between the primary and secondary seals through the compensating holes in the pistons. The excess fluid in the system can flow back to the fluid reservoirs through the small compensating ports in the master cylinder bore.

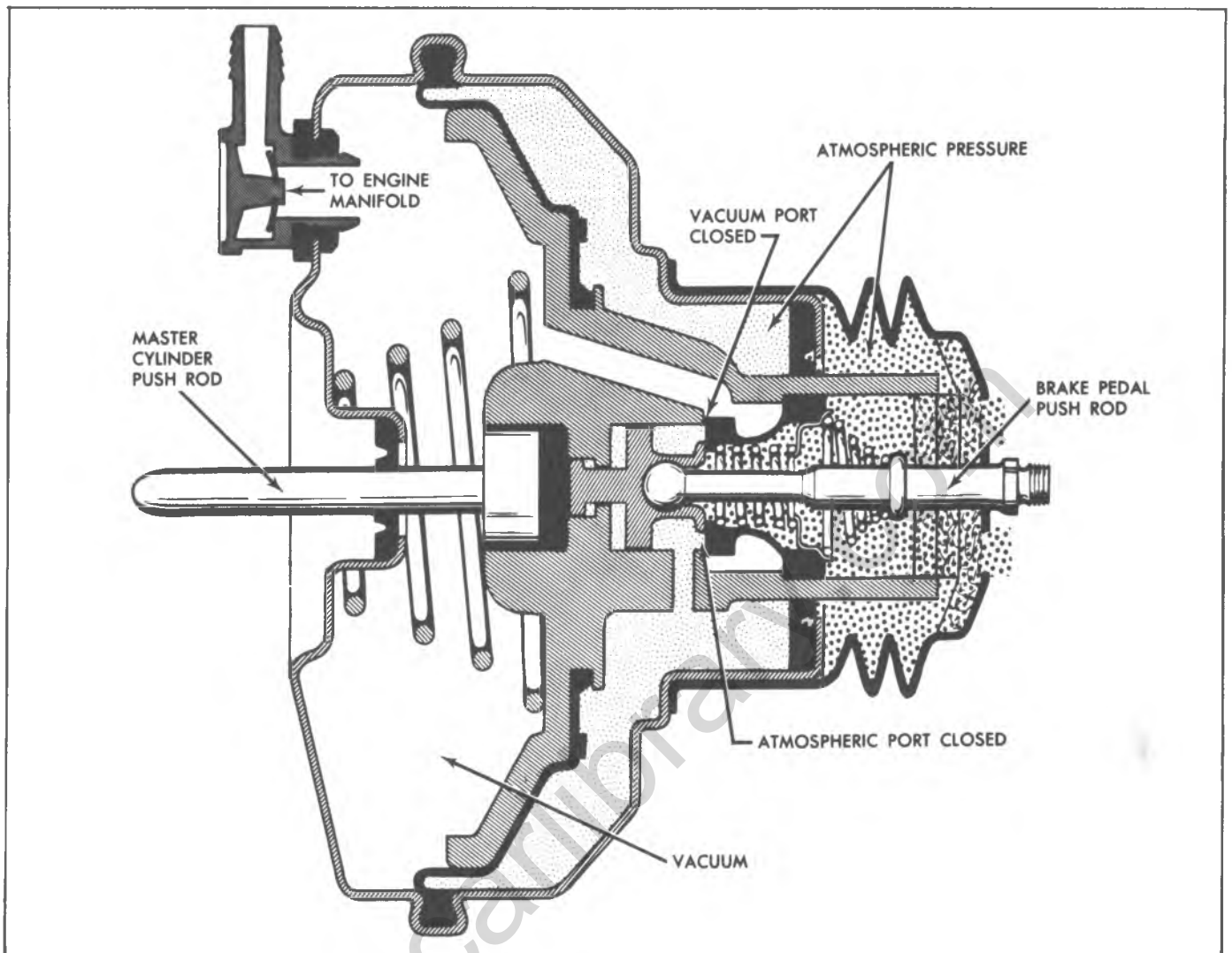

Fig. 87--Typical Circuit - Holding

## VACUUM FAILURE

In case of vacuum source interruption, the brake unit operates in the following manner:

As the pedal is pushed down, the end of the air valve contacts the reaction levers and pushes, in turn, against

the hydraulic reaction plate. Since the hydraulic reaction plate is fastened to the master cylinder piston rod, it forces the piston rod against the master cylinder primary piston, which builds up the hydraulic line pressure. With this condition you have, in effect, a standard brake unit.

## MAINTENANCE AND ADJUSTMENTS

### INSPECTIONS

1. Check vacuum line and vacuum line connections as well as vacuum check valve in front housing of power unit for possible vacuum loss.
2. Inspect all hydraulic lines and connections at the wheel cylinders and master cylinder for possible hydraulic leaks.
3. Check brake assemblies for scored drums, grease or brake fluid on linings, worn or glazed linings, and make necessary adjustments.
4. Check brake fluid level in the hydraulic reservoirs. The reservoirs should be filled to the levels shown in Figure 30.
5. Check for loose mounting bolts at master cylinder and at power section.
6. Check air cleaner filter in power piston extension and replace filter if necessary.
7. Check brake pedal for binding and misalignment between pedal and push rod.

## LUBRICATION

The power brake unit is lubricated at assembly and needs no further lubrication other than maintaining normal reservoir fluid level. The reservoir should be filled as described in this section.

## BLEEDING

The power system may be bled manually or with a pressure bleeder as outlined in this section. Use only GM Hydraulic Brake Fluid Supreme 11 (or DOT-3 brake fluids). Do not use the power assist while bleeding. The

engine should not be running and the vacuum reserve should be reduced to zero by applying the brake several times before starting the bleeding procedure.

## AIR CLEANER SERVICE

Servicing of the air cleaner is recommended and the element replaced when restriction becomes severe enough to affect power brake response. At any other time, if cleaning of the filter is felt necessary, it should be shaken free of dirt or washed in soap and water and thoroughly dried.

# COMPONENT PART REPLACEMENT

## POWER BRAKE UNIT

### Replacement

1. Remove the vacuum hose from check valve.
2. Remove nuts securing the master cylinder to power cylinder.
3. Pull forward on the master cylinder until the cylinder clears the mounting studs on the power unit. Carefully move the master cylinder aside (brake lines attached). Support the cylinder to avoid stress on the brake lines.

**CAUTION:** Move the master cylinder only enough to allow room for removal of the power cylinder.

4. Remove the nuts securing the power unit to dash.
5. Remove the brake pedal push rod to pedal retainer (or bolt, nut and cotter pin on P models) and

disconnect the push rod from the pedal. Remove the power cylinder assembly.

6. If an overhaul is necessary, refer to the applicable model in the "Overhaul" manual.
7. To reassemble, reverse the removal procedure. Be sure to torque the master cylinder and power cylinder nuts to specifications.

**CAUTION:** See "Caution" on Page 1 of this section.

*Always replace the vacuum check valve when replacing or overhauling the power brake unit.*

*It is necessary upon completing reassembly to be sure that the brake lines are properly routed with adequate clearance to adjacent components and that brake operation and stop lamp adjustment is correct.*

## DIAGNOSIS

**NOTE:** The same types of brake troubles are encountered with power brakes as with standard brakes. Before checking the power brake system for source of trouble, refer to trouble diagnosis of standard hydraulic brakes in this manual. After these possible causes have been eliminated, check for cause as outlined below.

### BRAKE SYSTEM LOSES FLUID

Probable Cause	Remedy
1. External leak: leaking-pipe connections, hose, wheel cylinders, stop light switch, master cylinder head nut, etc.	1. Clean parts. Tighten. Replace defective parts.
2. Internal leaks: past secondary seals into power unit. Check vacuum hose for fluid.	2. Rebuild master cylinder.

**NOTE:** Make the following test before checking hard pedal for the cause. With the engine stopped, depress the brake pedal several times to eliminate all vacuum from the system. Apply the brakes, and while holding the foot pressure on the brake pedal, start the engine. If the unit is operating correctly, the brake pedal will move forward when the engine vacuum power is added to the pedal pressure. If this test shows that the power unit is not operating, the trouble may be one of the following:

### NO BOOST—HARD PEDAL

Probable Cause	Remedy
1. Bent, broken, obstructed tube. Collapsed hose.	1. Replace defective parts.
2. Stuck check valve.	2. Replace valve.
3. Air inlet blocked.	3. Replace filter. Open passages.
4. Air valve stuck.	4. Disassemble unit - clean - replace defective parts.
5. Faulty diaphragm.	5. Replace diaphragm.
6. Faulty piston seal.	6. Replace seal.
7. Leaks internally.	7. Rebuild as outlined in the "Overhaul" Manual. Tighten bolts.

## DIAGNOSIS—POWER HYDRAULIC BRAKES

## SLOW BRAKE PEDAL RETURN

Probable Cause	Remedy
1. Excessive seal friction in power unit.	1. Overhaul unit as outlined in the "Overhaul" Manual.
2. Faulty valve action.	2. Overhaul unit.
3. Broken return spring.	3. Replace spring.
4. Excessive pedal pivot friction.	4. Replace pivot bushings and lubricate with Delco Brake Lube #5450032 (or equivalent).

## BRAKES GRABBY

Probable Cause	Remedy
1. Broken valve spring.	1. Overhaul unit.
2. Sticking vacuum valve.	2. Clean and lubricate with Delco Silicone Lube #5459912 (or equivalent).
3. Reaction diaphragm leakage.	3. Overhaul unit.

## BRAKES CHATTER: PEDAL VIBRATES (BELLOWS TYPE)

Probable Cause	Remedy
1. Brake pedal free play not adjusted properly.	1. Adjust brake pedal free play.

## BRAKE PEDAL CHATTER (BELLOWS TYPE)

Probable Cause	Remedy
1. Power brake trigger is out of adjustment or bent.	1. Replace trigger and adjust linkage.
2. Master cylinder push rod is improperly adjusted.	2. Adjust push rod.
3. Power brake trigger rubber collar is missing or damaged.	3. Replace with new collar.
4. Binding inside power unit.	4. Overhaul unit.

**NOTE:** If trouble is determined as being caused by the power booster, refer to the applicable Service or Overhaul Manual for service procedures.



## HYDRO-BOOST INDEX

General Description .....	5-67	Brake Pedal Adjustment.....	5-71
Booster .....	5-67	Stoplamp Switch Adjustment.....	5-71
Accumulator .....	5-68	Component Part Replacement.....	5-72
Caliper .....	5-68	Hydraulic Brake Booster .....	5-72
Theory of Operation.....	5-69	Brake Pedal Rod.....	5-73
Maintenance and Adjustments .....	5-70	Accumulator.....	5-73
Bleeding Hydro-Boost/Power Steering		Shoe and Linings-Disc Brake.....	5-74
Hydraulic System .....	5-70	Caliper Overhaul.....	5-77
Bleeding Brake Hydraulic System .....	5-71	Disc Servicing.....	5-79

**NOTE UNLESS OTHERWISE SPECIFIED IN THE FOLLOWING PAGES, PROCEDURES AND PRACTICES REMAIN THE SAME AS DESCRIBED UNDER "STANDARD BRAKES" IN THIS SECTION.**

### GENERAL DESCRIPTION

All vehicles equipped with RPO JB8 and JB9 incorporate the Bendix Hydro-boost brake apply system. Two basic differences exist between the Hydro-boost and the previously discussed vacuum power brake system:

1. Hydro-boost systems utilize power steering fluid (in place of engine vacuum) to provide power assisted brake applications.
2. Hydro-boost eliminates the need for remote (frame) mounted boosters.

Components peculiar to this system include:

#### BOOSTER

The Hydraulic Brake Booster is a basic open center spool valve and a hydraulic cylinder combined into a single housing. The booster utilizes the hydraulic pressure supplied by the power steering pump to provide a power assist that operates a dual master cylinder brake system.

A typical hydraulic booster assembly is shown in Figure 88. The forward end of the booster includes a flange for

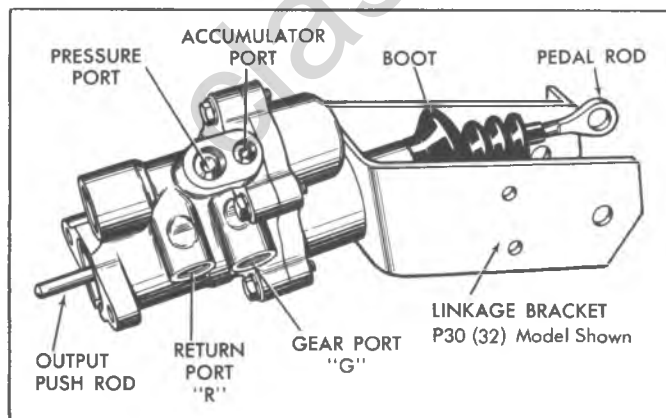

Fig. 88-Bendix Hydraulic Brake Booster

attaching a master cylinder with an output push rod projecting from the booster cylinder bore. When the master cylinder is attached to the booster, the output push rod fits into the primary piston in the master cylinder bore.

**NOTE:** In these service procedures, the term "forward" refers to the master cylinder end of the booster, and the term "rear" refers to the pedal rod end of the booster.

The booster power section (fig. 88) includes four ports; each port contains an aluminum tube seat insert. The ports are as follows:

1. Pressure Port (11/16-18 thread)--The high pressure line from the power steering pump is connected to this port.
2. Gear Port (5/8-18 thread)--The high pressure line leading to the power steering gear is connected to this port which is identified by the letter "G" cast below the port.
3. Return Port (9/16-18 thread)--The return line to the power steering pump reservoir is connected to this port which is identified by the letter "R" cast below the port.
4. Accumulator Port (1/2-20 thread)--The high pressure line to the spring accumulator is connected to this port.

A linkage bracket is attached to the rear of the booster assembly. The input rod end projects from the hub of the booster cover; the pedal rod is inserted into the input rod end. A boot seats on the pedal rod and the hub of the booster.

The external part of the power section consists of a housing and cover which are fastened together by five screws.

The valve bore in the housing contains a spool and

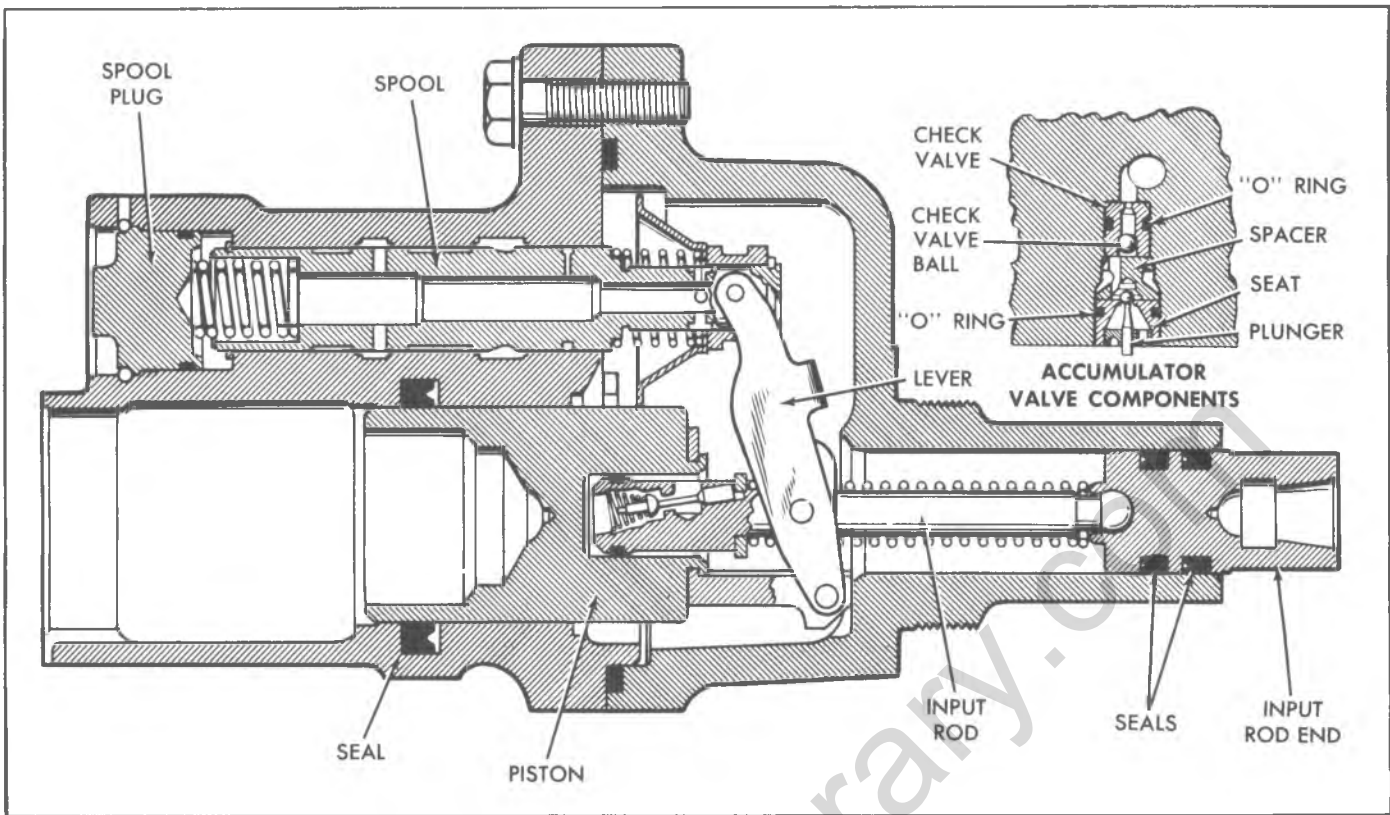

Fig. 89--Cross Section of Booster Components in Released Position

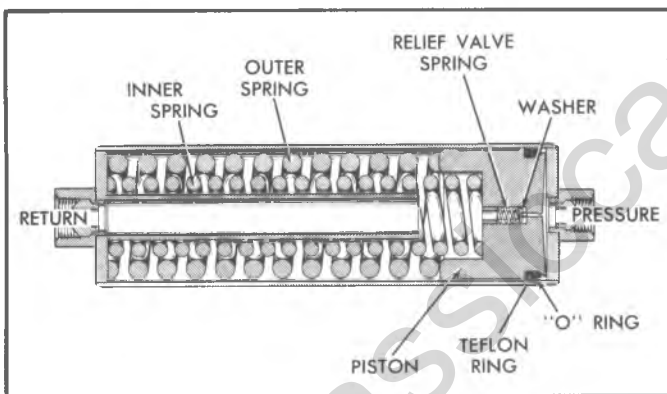

Fig. 90--Cross Sectional View of Accumulator

sleeve assembly with an actuator attached to the rear end of the spool. A piston is inserted through a lip type seal in the hydraulic cylinder of the housing.

The piston is a part of the input rod and piston assembly. Two lip type seals are assembled on the input rod end inside the hub of the cover.

The accumulator valve components, shown in Figure 89, are assembled in the accumulator valve bore which is machined in the housing. This bore is connected to the accumulator port and by a passage to the pressure port.

## ACCUMULATOR

A spring accumulator (fig. 90) is used in conjunction with the hydraulic brake booster. The accumulator is a sealed hydraulic cylinder with a port at each end.

**WARNING:** Do not attempt to disassemble or cut into the accumulator. The accumulator contains springs compressed under high pressure.

## CALIPER

The front disc brake caliper is of the single piston design. The sliding caliper attaches to and slides within its supporting member, the steering arm/knuckle, which is a one-piece casting (fig. 91). The caliper assembly is held in place with a support key and spring. A screw prevents the key from sliding on the steering knuckle.

The linings are riveted to the brake shoes. The inboard and outboard shoe and linings are not interchangeable.

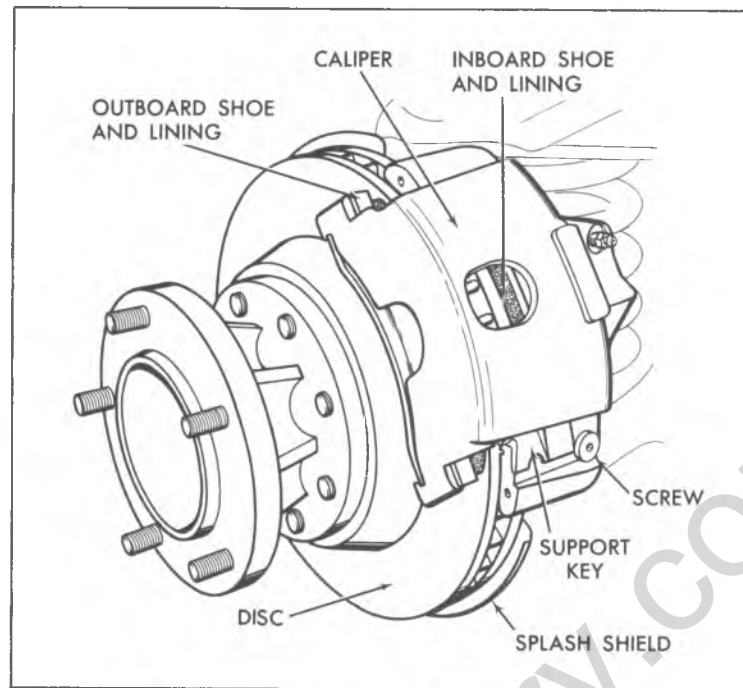

Fig. 91--Disc Brake Caliper Assembly Installed

## THEORY OF OPERATION

A schematic view of a Hydraulic Booster Brake System is shown in Figure 92. Note that the output of the power steering pump is routed to the hydraulic booster power section.

Three output lines are connected to the power section. One line leads to the power steering gear, one to the accumulator, and the other line is a return line back to the reservoir of the power steering pump.

A return line from the accumulator and a return line

from the power steering gear also lead back to the pump reservoir.

### Released Position

When the hydraulic power section is in the released position, most of the power output of the steering pump is routed on through the power section and to the steering gear (fig. 92). A portion of the fluid is diverted into the power section, and returns to the power steering pump reservoir through the return line.

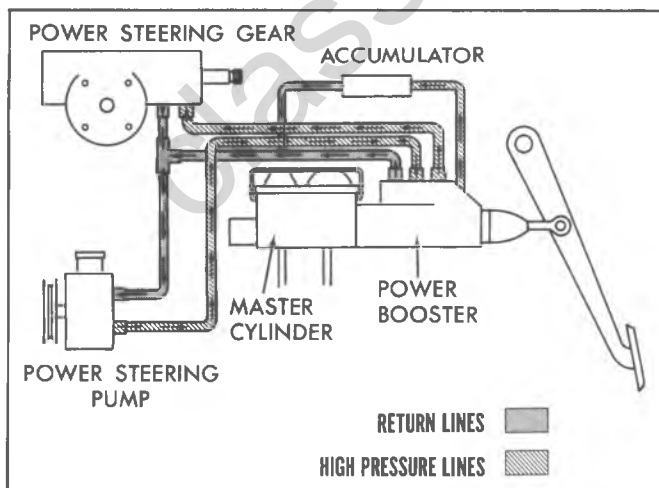

Fig. 92--Brake Booster Hydraulic Schematic

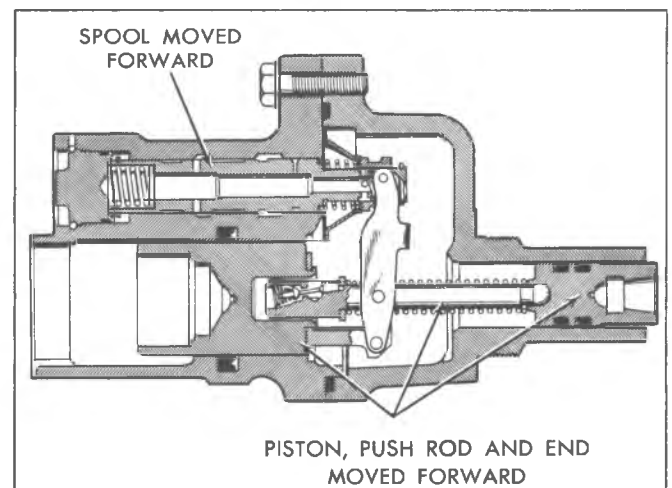

Fig. 93--Booster Assembly in Applied Position

### Applied Position

When the brake pedal is depressed, the input rod and piston move slightly forward. The lever assembly moves the sleeve forward to close off the four holes leading to the open center of the spool. A small additional movement of the lever moves the spool forward in the bore. The forward movement of the spool diverts additional hydraulic fluid into the cavity behind the booster piston to build up hydraulic pressure in this area. This moves the piston and the output rod forward (fig. 93) to activate the master cylinder and apply the brakes. Although some of the fluid from the power steering pump is diverted to activate the hydraulic booster, sufficient fluid continues to flow to the power steering gear for power steering operation.

### Releasing

When the brake pedal is released, the spool and sleeve assembly returns to its normal position, and the excess fluid behind the piston returns to the pump reservoir through the return line.

### Spring Accumulator

The spring accumulator is designed to store sufficient fluid under pressure to provide two or three power assisted brake applications in the event that the flow of

fluid from the power steering pump is interrupted (broken belt, engine failure, power steering pump failure, hose rupture, etc.).

The accumulator is charged with fluid (the accumulator springs are compressed) when the power steering valve is activated by turning the steering wheel or when the hydraulic brake booster is activated by applying the brake (fig. 93).

If the brakes are applied with the power steering pump not operating (because the engine is not running or some failure), the actuator on the end of the spool and sleeve assembly opens the plunger in the accumulator valve bore. This allows the pressurized fluid to enter the booster power section and provide a power assist. Normally, the accumulator should provide three power assisted brake applications under these conditions.

### Manual Brake Application

The design of the hydraulic booster permits the vehicle operator to apply the brakes manually (without a power assist) if fluid under pressure is not available from the power steering pump or accumulator, however, a somewhat greater pedal effort is required to apply the brakes manually.

## MAINTENANCE AND ADJUSTMENTS

### BLEEDING HYDRO-BOOST/POWER STEERING HYDRAULIC SYSTEM

1. Fill the power steering pump reservoir to the proper level with GM Power Steering Fluid (or equivalent) and let the fluid remain undisturbed for two minutes.
2. Start the engine and run for approximately two seconds.
3. Check the fluid level in the reservoir; add fluid if necessary.
4. Repeat the above procedure until the fluid level remains constant after the engine has been run as in Step 2 above.
5. Raise the front end of the vehicle so that the tires are clear of the ground.
6. Start the engine and run at approximately 1500 rpm. Depress and release the brake pedal several times. Turn the steering wheel right and left, lightly contacting the wheel stops.

7. Turn off the engine and check the fluid level in the reservoir; add fluid if necessary.
8. Lower the vehicle, start the engine and run at approximately 1500 rpm. Again, apply and release the brake pedal several times. Turn the steering wheel to full right and left.
9. Turn off the engine and check the fluid level in the reservoir; add fluid if necessary.
10. If the fluid is extremely foamy, allow the vehicle to stand a few minutes with the engine off, and repeat Steps 1 through 9 above.
11. Erratic pedal feel is an indication of excessive air in the power steering system. Allow vehicle to stand a few minutes with engine off and then repeat Steps 1-9 above.

## BLEEDING BRAKE HYDRAULIC SYSTEM

Bleeding of the Hydraulic Brake System is described under "Bleeding Hydraulic System" in the Standard Brake portion of this section.

## BRAKE PEDAL ADJUSTMENT

### C Models

The brake pedal push rod is not adjustable on C models.

### P30(32) Models

1. With the brake pedal pull back spring installed, brake pedal hard into bumper, brake master

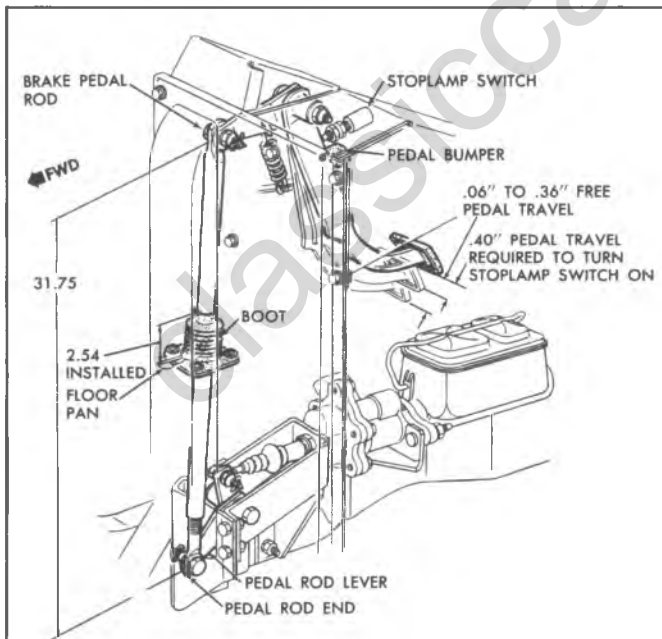

Fig. 94--Brake Pedal and Stop Lamp Adjustment--P30(32) Model

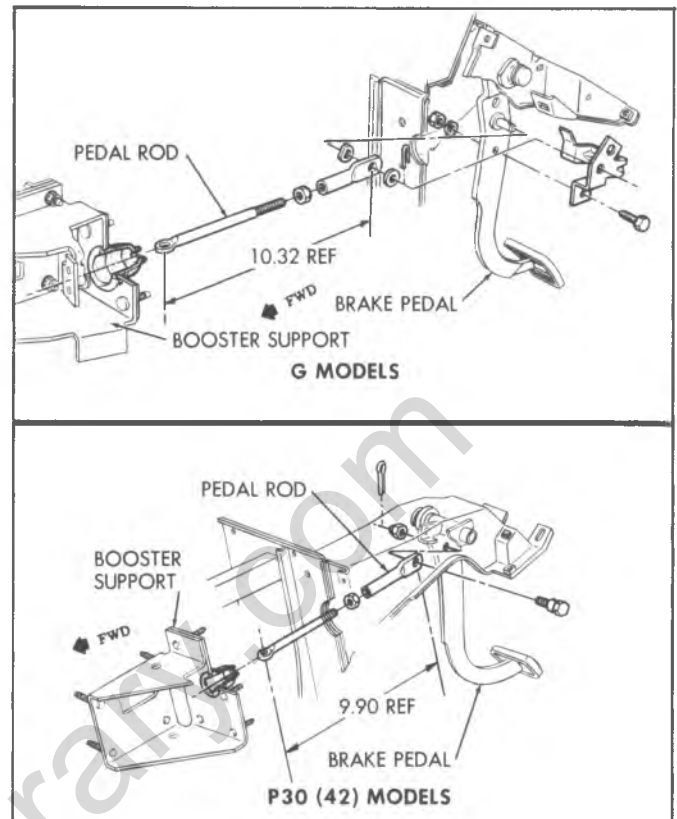

Fig. 95--Brake Pedal Adjustment--P30(42) and G Models

cylinder assembly and brake pedal rod lever at full return, install pre-assembled brake pedal rod assembly (rod, end and boot).

NOTE: Pre-assembled brake pedal rod assembly should be adjusted to dimension shown in Figure 94.

2. Adjust free pedal travel by turning the brake pedal rod end. Free pedal travel should be .06" to .36" (fig. 94).
3. Fasten boot to floorpan assembly and compress boot to 2.54" installed height.

NOTE: Pedal travel in a "power off" situation (engine off-accumulator depleted) should not be more than 6" under a 90# load.

### P30(42) and G Models

1. Adjust the pedal rod to the length shown in Figure 95 and install in the vehicle.
2. Check pedal height and adjust to the dimensions shown in Figure 41.

## STOPLAMP SWITCH ADJUSTMENT

1. Release the brake pedal to its normal position.
2. Loosen the switch locknut. Rotate the switch in its

bracket. Electrical contact should be made when pedal travel is  $3/8 - 5/8''$ .

3. Tighten switch locknut and connect electrical harness.

## COMPONENT PART REPLACEMENT

### HYDRAULIC BRAKE BOOSTER

#### Removal (Fig. 96-98)

1. Depress and release the brake pedal several times (engine not running) to be sure that all pressure is discharged from the accumulator prior to disconnecting the hoses from the booster.
2. **P30(32) Models** - Raise the vehicle on a hoist.
3. Clean all dirt from the booster at the hydraulic line connections and master cylinder.
4. Remove the nuts and lockwashers that secure the master cylinder to the booster and the support bracket. Support the master cylinder, being careful to avoid kinking or bending the hydraulic lines attached to the master cylinder. Cover the end of the master cylinder with a clean cloth.

NOTE: It should not be necessary to disconnect the hydraulic lines from the master cylinder.

5. Disconnect the hydraulic lines from the booster ports. Plug all lines and the booster ports to prevent loss of fluid and to keep out foreign material.
6. **P30(42) and C-G Models** -
  - a. Remove booster pedal push rod cotter pin and washer and disconnect the push rod from the brake pedal (C models) or booster bracket pivot lever (G and P models).
  - b. Remove the booster support bracket on C models, support braces on G and P30(42) models.
  - c. Remove the booster bracket to dash panel or

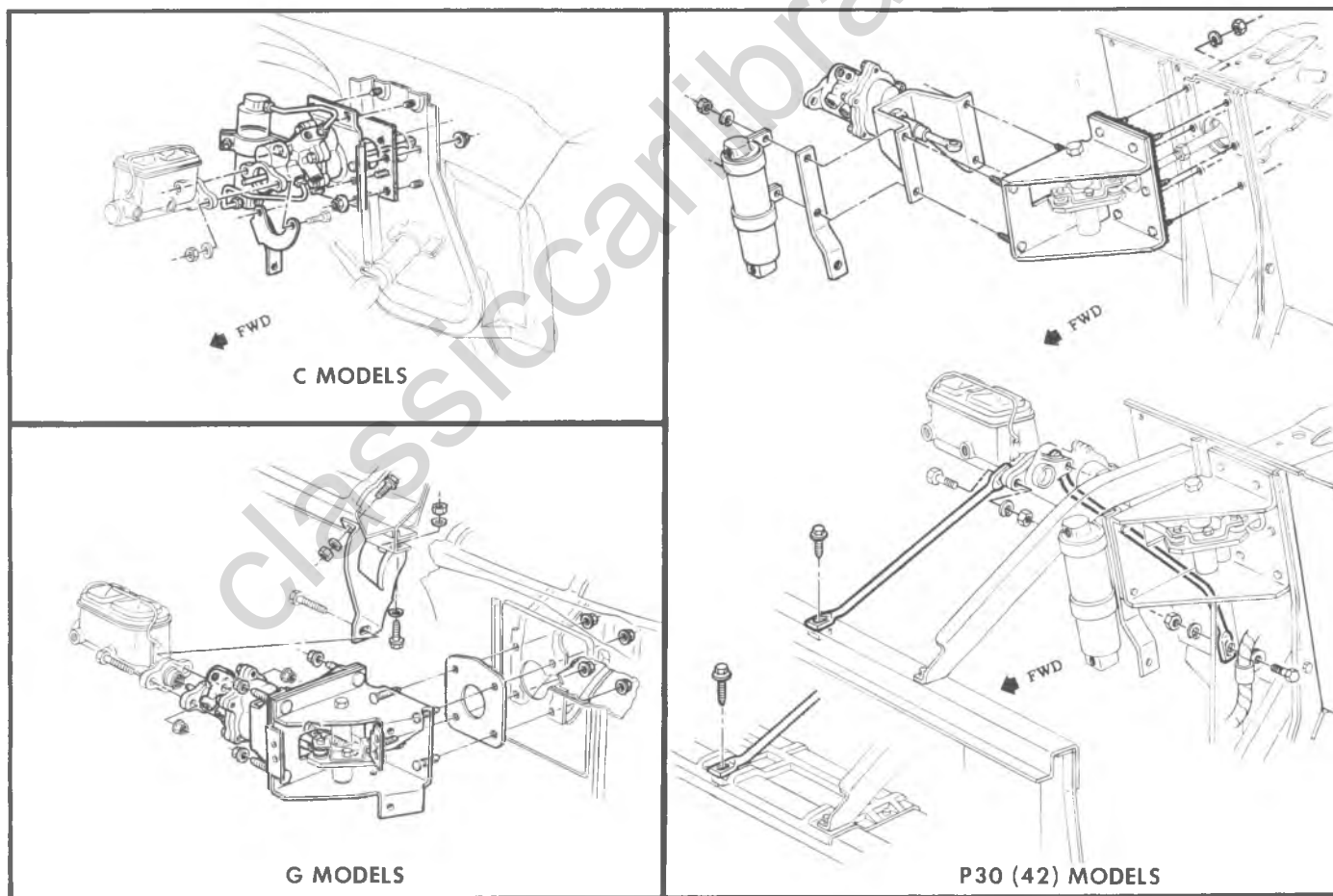

Fig. 96-Booster Installation - Except P30(32) Models

support bracket nuts and remove the booster assembly.

7. **P30(32) Models -**
  - a. Remove the cotter pin, nut, bolt and washers that secure the operating lever to the vertical brake rod.
  - b. Remove the six nuts, lockwashers and bolts that secure the booster linkage bracket to the front and rear support brackets, and remove the booster from the vehicle by sliding the booster off the rear support studs.
  - c. Remove the cotter pin, nut, washer and bolt that secures the operating lever to the pedal rod.
  - d. Remove the brake pedal rod lever nut and bolt and then remove the lever, sleeve and bushings.
8. To install, reverse Steps 1-7 above. Torque all hydraulic lines and attaching bolts to specifications.
 

NOTE: Lubricate pedal rod and linkage pivot bolts, pins, sleeves and bushings with Delco Brake Lube **5450032** (or equivalent).

**CAUTION:** See "Caution" on Page 1 of this section.
9. Bleed the booster/power steering hydraulic system as described under "Maintenance and Adjustment".
10. Check brake pedal and stoplamp switch adjustment.

## BRAKE PEDAL ROD

### P30(32) Models

#### Replacement (Fig. 94)

1. Remove the cotter pin, nut, special washers and bolt at the brake pedal lever end of rod; discard the cotter pin.
2. Remove the boot to floorpan screws.
3. Raise the vehicle on a hoist.
4. Remove the cotter pin, nut, special washers and bolt at the lower end of the rod and remove the pedal rod assembly. Discard the cotter pin.
5. To install a new rod, adjust the rod length to 31.75" (center of upper attachment to center of lower attachment).
6. Lubricate the pedal rod bolts and special washers with Delco Brake Lube #5450032 (or equivalent).
7. Install the rod up through the floorpan opening and install the lower pivot bolt, special washers and nut. Tighten the nut to 22-30 ft. lbs. and install a NEW cotter pin.
8. Push the boot up to the floorpan.
9. Lower the vehicle from the hoist.
10. Install the rod upper pivot bolt, special washers and nut. Tighten the nut to 22-30 ft. lbs. and install a NEW cotter pin.

11. Fasten the boot to the floorpan and compress the boot to 2.54" installed height; tighten the boot screws to 13-18 in. lbs. Refer to Figure 94.
12. Adjust brake pedal and stoplamp switch as outlined under "Maintenance and Adjustments".

### P30(42) and G Models

#### Replacement (Fig. 95)

1. **G Models** - Remove the brake pedal striker screw and remove the striker. Remove the cotter pin and washer and disconnect the pedal rod from the brake pedal.
2. **P30(42) Models** - Remove the cotter pin nut and bolt to disconnect the pedal rod from the brake pedal.
3. Remove the pedal rod retainer bolt (at the rod pivot) and remove the retainer.
4. Remove the cotter pin and washer and remove the pedal rod.
5. To install a new rod, adjust the rod length to 9.90" on P30(42) models or 10.32" on G Models. Reverse Steps 1-4 above.

NOTE: Lubricate pivot points with Delco Brake Lube #5450032 (or equivalent).

**CAUTION:** See "Caution" on Page 1 of this section.

6. Check brake pedal and stoplamp switch adjustments as outlined under "Maintenance and Adjustments".

## ACCUMULATOR

**WARNING:** Do not attempt to disassemble the accumulator or cut into the accumulator under any circumstances. The accumulator contains springs compressed under high pressure.

#### Removal (Fig. 99)

1. Depress and release the brake pedal several times (engine not running) to be sure that all residual pressure is discharged from the accumulator.
2. **P30(32) Models** - Raise the vehicle on a hoist.
3. Clean all dirt from the accumulator hydraulic lines.
4. Disconnect the hydraulic line from each end of the accumulator. Plug each line and the accumulator ports to prevent leakage and to keep out foreign material.
5. Remove the accumulator bracket attachments and remove the accumulator from the vehicle.

#### Installation

1. Secure the new accumulator to the vehicle with the

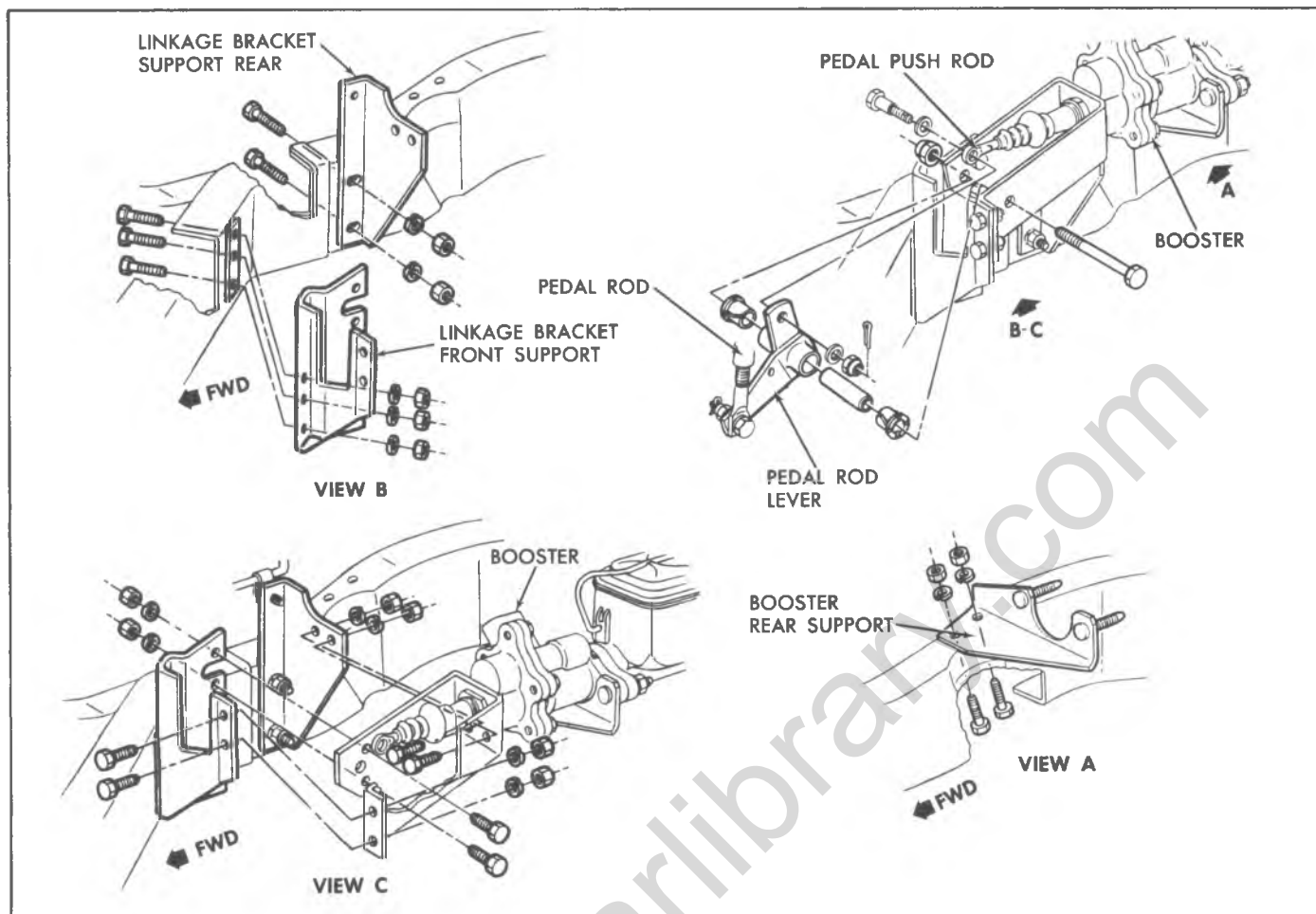

Fig. 97-Booster Installation - P30(32) Models

bolt and bracket; torque the nut to 14-22 ft. lbs. Be sure that the new accumulator is in the same position as the old accumulator (the high pressure port has 1/2-20 threads, and the return line port has 5/8-18 threads).

2. Remove the plugs from the hydraulic lines, and connect the lines to the accumulator ports; torque the 5/8" nut to 140-190 in. lbs., the 1/2" nut to 120-165 in. lbs.
3. **P30(32) Models** - Lower the vehicle from the hoist.
4. Bleed the booster/power steering hydraulic system as described under "Maintenance and Adjustments".

### SHOE AND LININGS--DISC BRAKE

The brake linings should be inspected any time the wheels are removed. Check both ends of the outboard shoe by looking in at each end of the caliper. This is the point at which the highest rate of wear normally occurs. At the same time, check the lining thickness on the inboard shoe by looking down through the inspection hole in the top of the caliper; see "Brake Inspection" portion of this section. The inboard shoe is installed with

the ends of the shoe resting in the steering knuckle. The large tab at the bottom of the outboard shoe is bent over at a right angle and fits in the cutout in the outboard section of the caliper.

**NOTE:** The inboard shoe does not incorporate a lining wear sensor as with standard disc brakes.

### Removal

1. Remove master cylinder cover and observe brake fluid level in front reservoir. If reservoir is more than 1/3 full, siphon the necessary amount out to bring the level to 1/3 full. This step is taken to avoid reservoir overflow when the caliper piston is pushed back into its bore. Discard the brake fluid removed. Never reuse brake fluid.
2. Raise the front of the vehicle on a hoist and remove the front wheels.
3. Push the piston back into its bore. This can be accomplished by using a "C" clamp as shown in Figure 100.



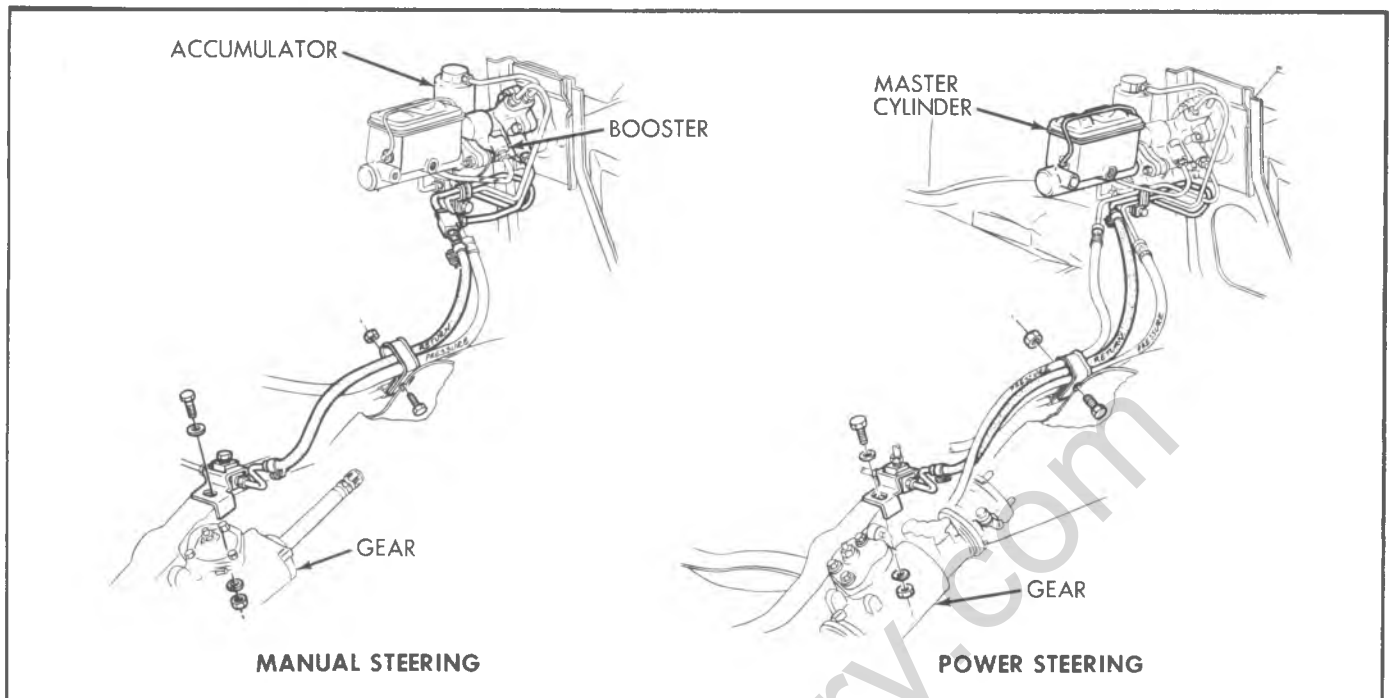

Fig. 98--Hydraulic Line Routing--C Model Shown as Typical

4. Remove the bolt at the caliper support key. Using a brass punch, remove the key and spring (fig. 101).
5. Lift the caliper off the disc and support in a raised position with a heavy wire (fig. 102).

**CAUTION:** Do not support the weight of the caliper on the brake hose.

6. Remove the inboard shoe from the steering knuckle. Remove and discard the inboard shoe clip. Remove the outboard shoe from the caliper. It may be necessary to tap the shoe to loosen it in the caliper housing.

**CAUTION:** Mark disc pad positions if pads are to be reinstalled.

#### Cleaning and Inspection

**NOTE:** The shoes should be replaced when the lining is worn to approximately 1/32" thickness over the rivet heads. Replace shoes in axle sets.

1. Examine the inside of the caliper for evidence of fluid leakage. If leakage is noted, the caliper should be overhauled.
2. Wipe the inside of the caliper clean, including the exterior of the dust boot. Check the boot for cuts, cracks or other damage.

**CAUTION:** Do not use compressed air to clean the inside of the caliper.

3. Use a wire brush to remove any rust or corrosion from the machined surfaces of the steering knuckle and caliper. It is important to clean those areas of

the caliper and spindle assembly that are in contact during the sliding action of the caliper.

#### Installation

**CAUTION:** If original disc pads are being reinstalled, they must be installed in original positions (as marked at removal).

1. Lubricate the caliper and steering knuckle sliding surfaces and the support spring with Delco Silicone Lube #5459912 (or equivalent).
2. Install a NEW inboard shoe clip in the steering knuckle. Be sure the tabs are positioned correctly and the loop-type spring positioned away from the rotor. Install the lower end of the inboard shoe into the groove provided in the steering knuckle (against the spring clip). Slide the upper end of the shoe into position. Be sure the clip remains in position.
3. Position the outboard shoe in the caliper with the ears at the top of the shoe over the caliper ears and the tab at the bottom of the shoe engaged in the caliper cutout. If assembly is difficult, a "C" clamp may be used. Be careful not to mar the lining.
4. With both shoes installed, lift up the caliper and rest the bottom edge of the outboard lining on the outer edge of the brake disc to make sure there is no clearance between the tab at the bottom of the outboard shoe and the caliper abutment. The outboard shoe should fit tightly in the caliper and should not rattle.
5. Position the caliper over the brake disc, guiding the upper caliper groove onto the mating surface of the

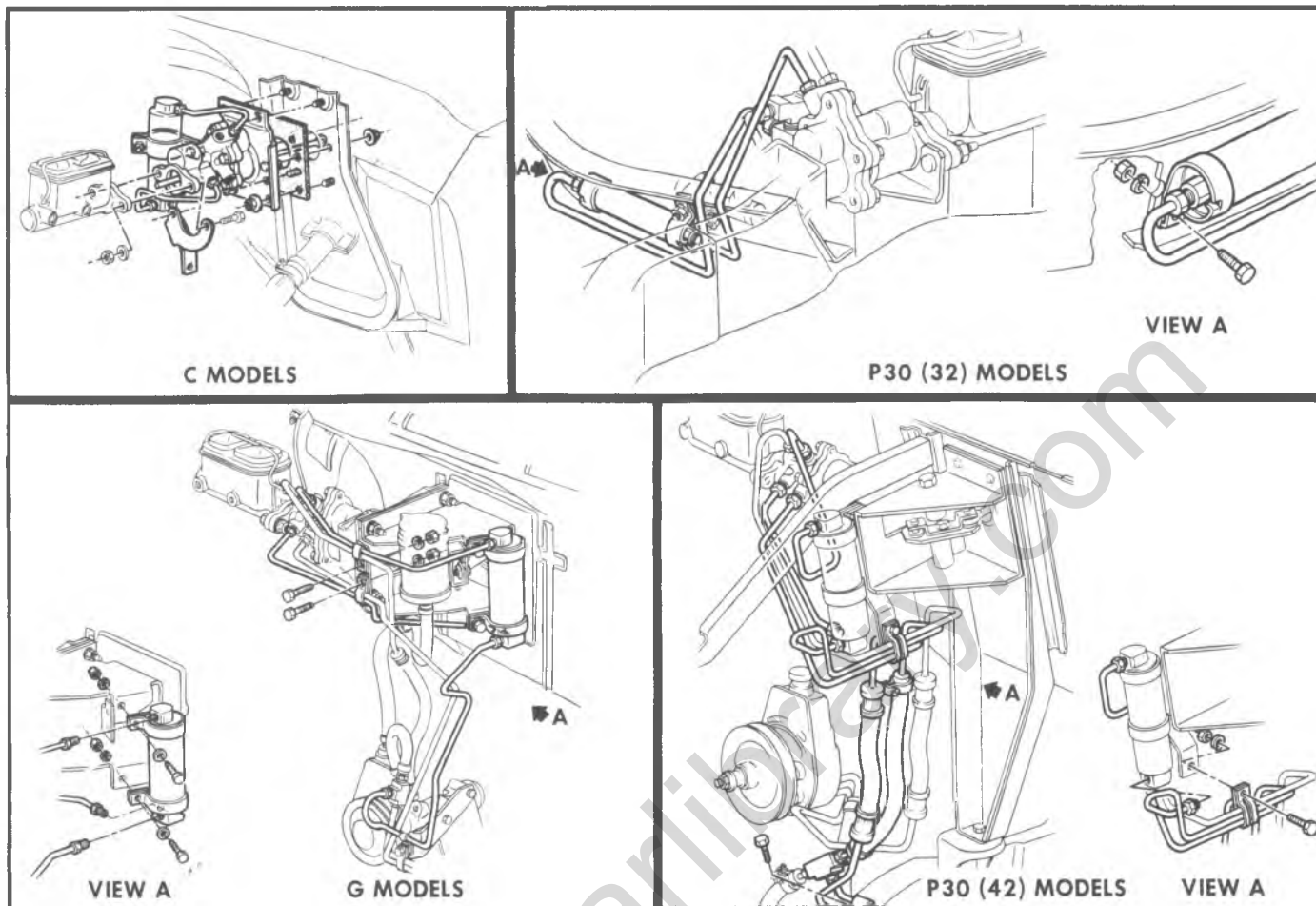

Fig. 99--Accumulator Installation

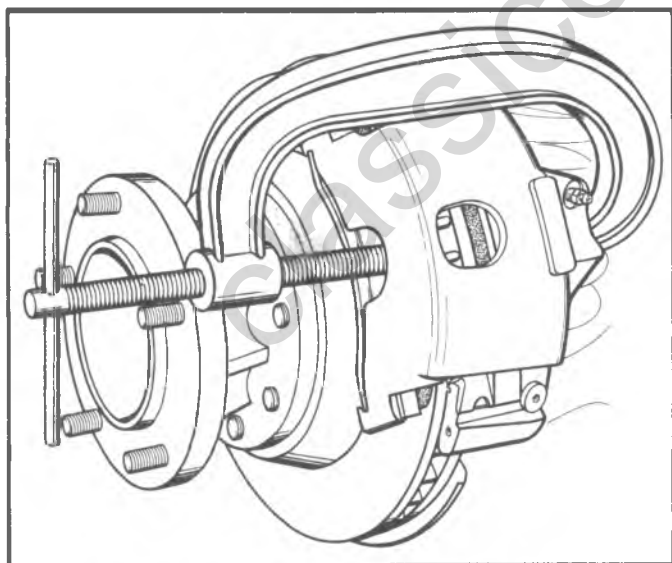

Fig. 100--Pushing Piston into Bore Using a "C" Clamp

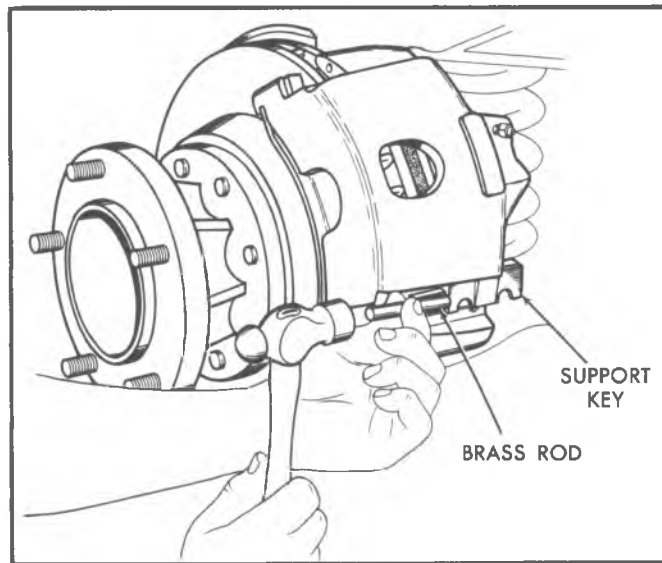

Fig. 101--Removing the Caliper Support Key

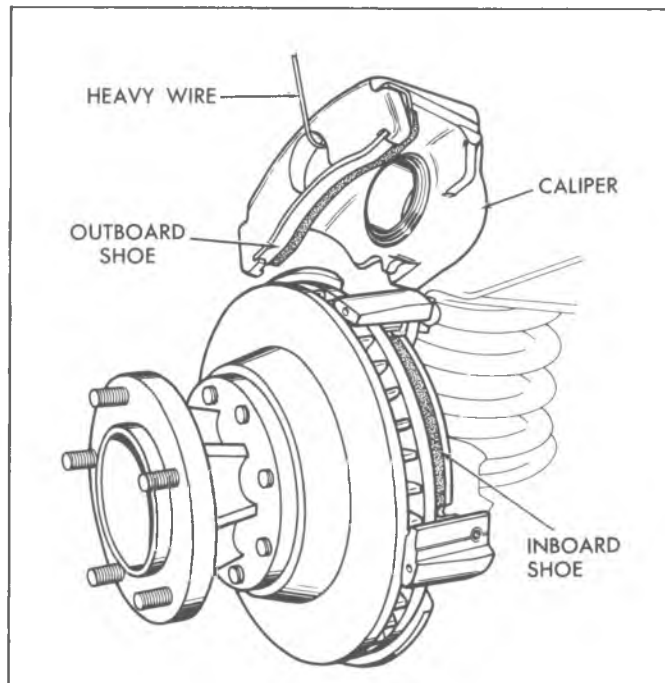

Fig. 102--Removing Caliper from the Disc

steering knuckle. Position the caliper to the lower steering knuckle sliding surface.

NOTE: Make sure that the brake hose is not twisted or kinked.

6. Place the spring over the caliper support key, install the assembly between the steering knuckle and lower caliper groove. Tap into place (until the key retaining screw can be installed) using a brass punch and a light hammer (fig. 103).
7. Install the screw and torque to 12 to 18 ft. lbs.  
**CAUTION:** The bolt boss must fit fully into the circular cutout in the key.  
See "Caution" on Page 1 of this section.
8. Reinstall the front wheel and tire assembly.
9. Add brake fluid to the master cylinder reservoir to bring the fluid level up to within 1/4 inch of the top.

NOTE: Before moving the vehicle, pump the brake pedal several times to make sure that it is firm. Do not move vehicle until a firm pedal is obtained. Check master cylinder fluid level again after pumping the brake pedal.

## CALIPER OVERHAUL

**CAUTION:** Always use clean brake fluid to clean caliper parts. Never use mineral-base cleaning solvents such as gasoline, kerosene, carbon tetrachloride, acetone, paint thinner or units of like nature as these solvents deteriorate rubber parts, causing them to become soft and swollen in an extremely short time.

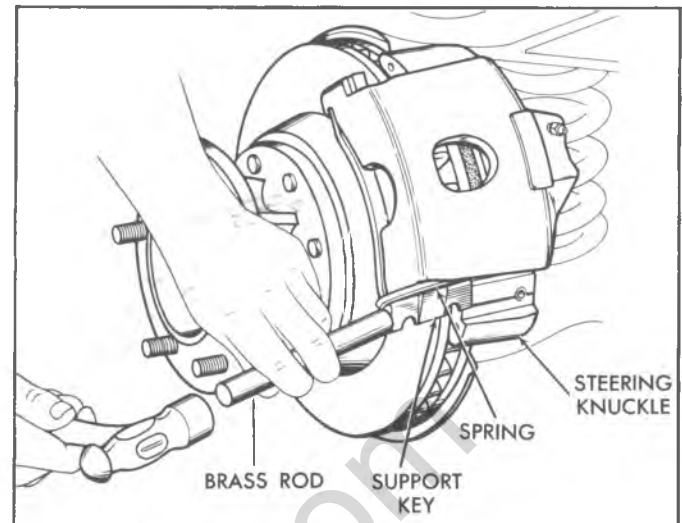

Fig. 103--Installing the Caliper Support Key

## Removal

**CAUTION:** Clean dirt from hose to caliper connection before proceeding with removal.

1. Remove the hose to caliper bolt and cap or tape the open connections to prevent dirt from entering the hose or caliper. Discard the copper gaskets.
2. Remove the caliper assembly as described under "Shoe and Linings-Removal".

## Disassembly (Fig. 104)

1. Clean the exterior of the caliper using clean brake fluid and place on a clean work surface.
2. Drain the brake fluid from the caliper.

**WARNING:** Do not place the fingers in front of the piston in an attempt to catch or protect it when applying compressed air.

3. Using clean shop cloths, pad the interior of the

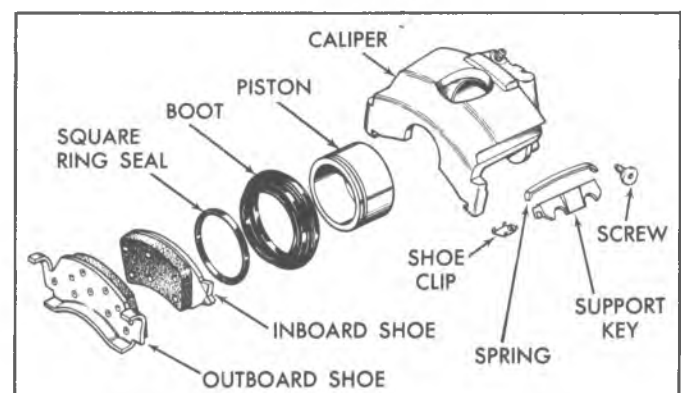

Fig. 104--Brake Caliper Assembly

caliper and remove the piston by directing compressed air into the caliper inlet hole (fig. 105).

**CAUTION:** Use just enough air pressure to ease the piston out of the bore. Do not blow piston out of the bore. If the piston is seized or cocked or does not come out readily, release the air pressure and use a soft (brass) hammer to rap sharply on and around the end of the piston. Reapply air pressure to remove the piston.

**NOTE:** An alternate method of removing the piston is to stroke the brake pedal (gently) while the hydraulic lines are still connected. This will push the piston out of the caliper bore.

4. Remove the boot from the piston bore.
5. Using a small piece of wood or plastic, remove the square ring seal from the piston bore.

**CAUTION:** Do not use a metal tool of any kind for this operation as it may damage the bore.

6. Remove the bleeder valve from the caliper.

#### Cleaning and Inspection

**CAUTION:** The dust boot and piston seal are to be replaced whenever the caliper is overhauled. Discard these parts.

1. Clean all parts (other than those mentioned above) in clean brake fluid. Use dry, filtered, compressed air to blow out all passages in the caliper and bleeder valve.

**CAUTION:** The use of lubricated shop air will leave a film of mineral oil on the metal parts. This may damage rubber parts when they come in contact after reassembly.

2. Check the sliding surfaces of the caliper, steering knuckle and support spring for rust or corrosion. Clean up any surface defects with crocus cloth.

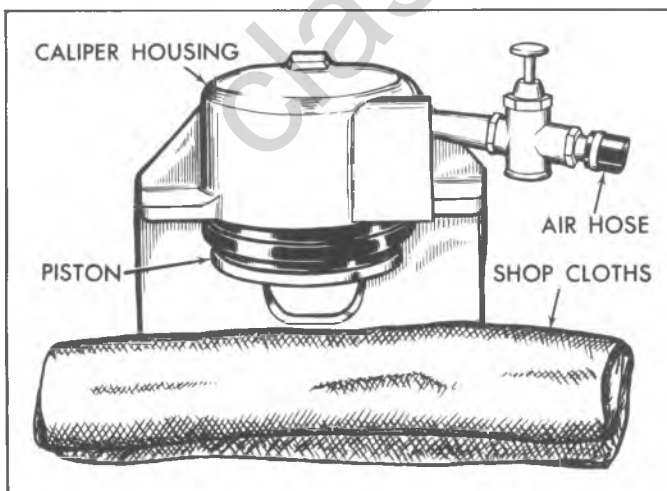

Fig. 105--Removing the Caliper Piston

3. Carefully examine the outside surface of the piston for scoring, nicks, corrosion and worn or damaged plating. If any surface defects are detected, replace the piston.

**CAUTION:** The piston outside diameter is the primary sealing surface in the caliper assembly. It is manufactured and plated to close tolerances. Refinishing by any means or the use of any abrasive is not an acceptable practice.

4. Check the bore in the caliper for the same defects as the piston. The piston bore, however, is not plated and stains or minor corrosion can be polished with crocus cloth.

**CAUTION:** Do not use emery cloth or any other form of abrasive. Thoroughly clean the caliper after the use of crocus cloth. If the bore cannot be cleaned up in this manner, replace the caliper.

#### Assembly

1. Lubricate the caliper piston bore and the NEW piston seal with the clean brake fluid. Position the square ring seal in the caliper bore groove.
2. Lubricate both sealing lips of the dust boot and the piston with a light film of clean brake fluid. Place the new boot over Piston Installer Tool J-24548. This is most easily accomplished by placing the boot large diameter over the tool first, then riding the smaller diameter onto the tool. The large diameter lip must then be slid off the tool to make ready for installation into the bore groove. Install the boot (large bead) into the piston bore groove by reaching inside of Tool J-24548 and pressing the boot bead into the groove (fig. 106).

**CAUTION:** Be sure boot is fully seated in the groove before proceeding.

3. Place the piston inside of Tool J-24548, force the piston halfway into the piston bore using a wood

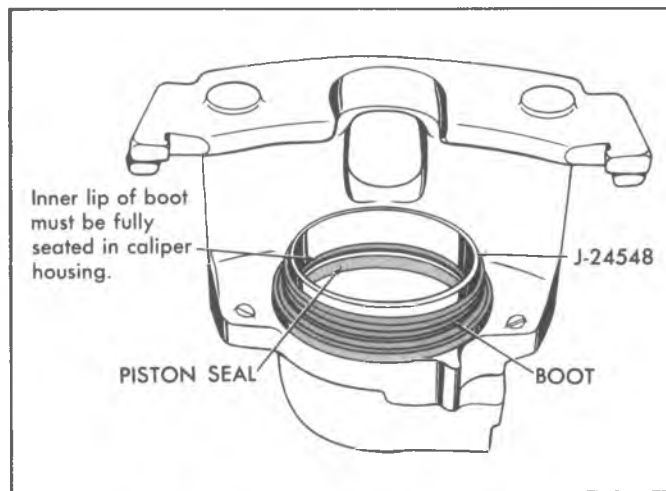

Fig. 106--Installing Caliper Piston Boot

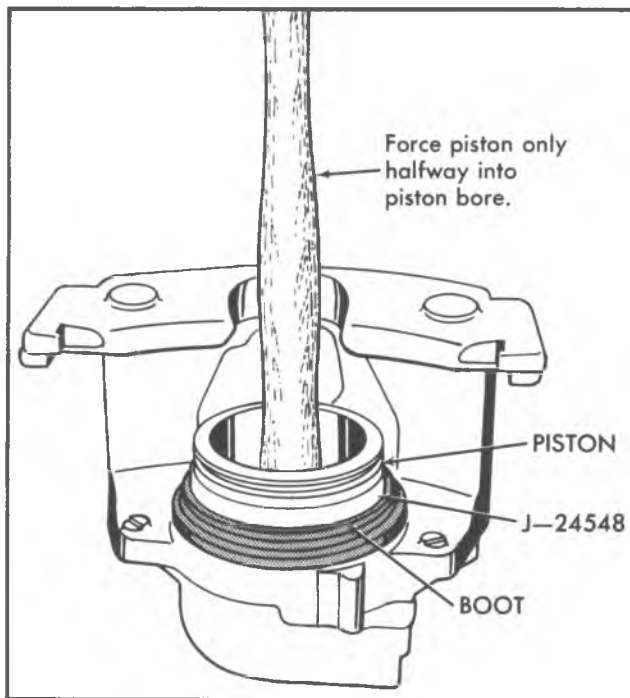

Fig. 107--Installing Piston in Caliper

hammer handle or "C" clamp (fig. 107); remove Tool J-24548. Check to be sure the boot was not unseated at piston installation. Make sure the outer bead of the boot is seated in the piston outer groove.

### Installation

NOTE: Installation of the caliper and mounting parts is the same for: "Shoe and Lining-Disc Brake" except for steps given below:

1. Connect the brake hose to the caliper using NEW copper gaskets.

**CAUTION:** *Hose must be properly positioned to prevent hose twist or misalignment.*

2. Bleed the caliper assemblies as outlined earlier in this section.

### DISC SERVICING

Disc servicing is performed in the same manner as described under "Disc Servicing" in the "Standard Brake" portion of this section. If refinishing is required, the following disc thickness dimensions must be adhered to:

MINIMUM THICKNESS AFTER REFINISHING	REPLACEMENT (DISCARD) THICKNESS
1.480	1.465

## DIAGNOSIS - HYDRO - BOOST SYSTEM

*NOTE: Before checking the hydraulic power booster for the source of trouble, refer to the trouble diagnosis procedures for Standard Brakes. After these possible causes have been eliminated, check for the probable cause and remedy as outlined below:*

### NO BOOST - HARD PEDAL

#### Preliminary Check

With the engine stopped, depress the brake pedal several times to eliminate all accumulator reserve from the system.

Hold the brake pedal depressed with medium pressure (25 to 35 lbs.), start the engine. If the unit is operating correctly, the brake pedal will fall slightly and then push back against the driver's foot, remaining at about the same position. If the booster is not operating correctly, the trouble may be one of the following causes:

Probable Cause	Remedy
1. Loose or broken power steering pump belt.	1. Tighten or replace the belt.
2. No fluid in power steering reservoir.	2. Fill reservoir and check for external leaks.
3. Leaks in power steering, booster or accumulator hoses.	3. Replace defective parts.
4. Leaks at tube fittings, power steering, booster or accumulator connections.	4. Tighten fittings or replace tube seats, if defective.
5. External leakage at accumulator.	5. Replace accumulator.
6. Faulty booster piston seal causing leakage at booster flange vent.	6. Replace all booster seals.
7. Faulty booster input rod seal with leakage at input rod end.	7. Replace all booster seals.
8. Faulty booster cover seal with leakage between housing and cover.	8. Replace all booster seals.
9. Faulty booster spool plug seal.	9. Replace all booster seals.
10. Internal leakage in booster.	10. Replace booster.
11. Contamination in power steering fluid.	11. Flush power steering system and replace with new fluid.

## DIAGNOSIS - HYDRO - BOOST SYSTEM

### SLOW BRAKE PEDAL RETURN

Probable Cause	Remedy
1. Excessive seal friction in booster.	1. Replace all booster seals.
2. Faulty spool action.	2. Clean spool and replace all booster seals.
3. Broken piston return spring.	3. Replace spring.
4. Restriction in return line from booster to pump reservoir.	4. Replace line.
5. Broken spool return spring.	5. Replace spring.
6. Excessive pedal pivot friction.	6. Lubricate pivot bushings with Delco Brake Lube #5450032 (or equivalent) or replace bushings.

### GRABBY BRAKES

Probable Cause	Remedy
1. Broken spool return spring.	1. Replace spring.
2. Faulty spool action caused by contamination in system.	2. Inspect, clean and replace all booster seals.

### BOOSTER CHATTERS - PEDAL VIBRATES

Probable Cause	Remedy
1. Power steering pump belt slips.	1. Tighten belt.
2. Low fluid level in power steering pump reservoir.	2. Fill reservoir and check for external leaks.
3. Faulty spool operation caused by contamination in system.	3. Inspect, clean and replace all booster seals.
4. Excessive contamination in power steering fluid.	4. Flush power steering fluid from system and replace with new power steering fluid.

## DIAGNOSIS - HYDRO - BOOST SYSTEM

### ACCUMULATOR LEAKDOWN - SYSTEM DOES NOT HOLD CHARGE

#### Preliminary Check

Start engine and turn the steering wheel until the wheels contact the wheel stops lightly. Hold for a maximum of five seconds. Then release the steering wheel and turn off the engine.

Depress and release the brake pedal. There should be a minimum of three power assisted brake applications before a hard pedal is obtained.

Re-start the engine and turn the steering wheel until the wheels contact the wheel stops lightly. There should be a light hissing sound as the accumulator is charged. Hold steering wheel lightly against stop for a maximum of five seconds. Then release the steering wheel, and turn off the engine.

Wait one hour and apply brake pedal (do not re-start the engine). There should still be a minimum of three power assisted brake applications before obtaining a hard pedal.

If either of these preliminary checks shows that the accumulator is not holding its charge, the trouble may be one of the following causes.

Probable Cause	Remedy
1. External leakage at accumulator welds.	1. Replace accumulator.
2. External leakage at accumulator fittings.	2. Tighten or replace fittings, as necessary.
3. Internal leakage in accumulator (past piston seal or relief valve).	3. Perform Accumulator Leakage Test as described below.
4. Internal leakage at booster accumulator valve (if accumulator is not leaking externally or internally).	4. Replace all booster seals and accumulator valves.

#### Accumulator Leakage Test

Start the engine and turn the steering wheel until the wheels contact the wheel stops lightly. Hold for a maximum of five seconds. Release the steering wheel, and turn off the engine.

**CAUTION:** Do not disconnect the fitting from the pressure side of the accumulator (this is the end connected to the booster) because the accumulator contains fluid under pressure.

Remove the fitting from the return end of the accumulator. This is the end connected to the power steering pump reservoir. Cap the line to the pump reservoir.

Allow excess fluid to drain from the accumulator. Then re-start the engine, and hold the wheels lightly against the wheel stops. There should be no continuous flow of fluid out of the accumulator return port. If there is a continuous flow, either the accumulator piston seal or the relief valve is leaking, and the accumulator should be replaced.



## SPECIAL TOOLS



Fig. 108--Special Tools

classiccarylbrary.com

## SECTION 6

# ENGINE

### CONTENTS OF THIS SECTION

Engine Tune-Up.....	6-1	Engine Mechanical (V8).....	6-45
Theory of Operation.....	6-15	Diagnosis.....	6-67
Engine Mechanical (In Line).....	6-20	Special Tools.....	6-74

## ENGINE TUNE-UP

### INDEX

General Description.....	6-1	Choke Adjustment.....	6-7
Mechanical Checks and Adjustments.....	6-1	Instrument Check-Out.....	6-8
Spark Plug Removal.....	6-1	Instrument Hook-Up.....	6-8
Test Compression.....	6-2	Check and Adjust Dwell.....	6-8
Service and Install Spark Plugs.....	6-2	Check Dwell Variation.....	6-8
Service Ignition System.....	6-2	Check and Adjust Timing.....	6-8
Service Battery and Battery Cables.....	6-3	Adjust Idle Speed.....	6-8
Service Delcotron and Regulator.....	6-5	Idle Mixture Adjustment Procedure.....	6-10
Service Belts.....	6-5	Additional Checks and Adjustments.....	6-12
Service Manifold Heat Valve.....	6-5	Cylinder Balance Test.....	6-12
Tighten Manifold.....	6-5	Battery.....	6-12
Service Fuel Lines and Fuel Filter.....	6-5	Ignition.....	6-12
Service Cooling System.....	6-5	Carburetor.....	6-13
Service Crankcase Ventilation.....	6-6	Fuel Pump.....	6-13
Service Air Injection Reactor System.....	6-6	Cooling System.....	6-13
Service Exhaust Gas Recirculation Valve.....	6-7	Cylinder Head Torque and Valve Adjustment.....	6-14

## GENERAL DESCRIPTION

The engine tune-up is important to the modern automotive engine with its vastly improved power and performance. Emission system requirements, interrelated system functions, improved electrical systems and other advances in design, make today's engines more sensitive and have a decided effect on power, performance and fuel consumption.

It is seldom advisable to attempt a tune up by correction of one or two items only. Time will normally be saved and more lasting results assured if the technician will follow a definite and thorough procedure of analysis and correction of all items affecting power, performance and economy.

The tune-up will be performed in two parts. The first part will consist of mechanical checks and adjustments; the second part will consist of an instrument checkout

that can be performed with any one of the units of service equipment available for this purpose. Always follow the instructions provided by the manufacturer of the particular equipment to be used.

Additional checks and adjustments are included in the latter part of this section for use as required. Many of these operations can be used to isolate and correct trouble located during the tune-up. Where conditions are uncovered requiring major corrective action, refer to the appropriate section of this manual or the Chassis Overhaul Manual for detailed service information.

Typical illustrations and procedures are used except where specific illustrations or procedures are necessary to clarify the operation. Illustrations showing bench operations are used for clarification, however, all operations can be performed on the vehicle.

## MECHANICAL CHECKS AND ADJUSTMENTS

### SPARK PLUG REMOVAL

Remove any foreign matter from around spark plugs by

blowing out with compressed air, then disconnect wires and remove plugs. To disconnect wire at spark plug,

## 6-2 ENGINE

grasp the boot portion of the wire and apply only enough force to remove the boot. Do not pull on plug wire.

### TEST COMPRESSION (FIG. 1)

The compression check is important because an engine with low or uneven compression cannot be tuned successfully. It is essential that improper compression be corrected before proceeding with the engine tune up.

1. Remove air cleaner and block throttle and choke in wide open position.
2. Hook up starter remote control cable and insert compression gauge firmly in spark plug port.

**CAUTION:** *Whenever the engine is cranked remotely at the starter, with a special jumper cable or other means, the distributor primary lead must be disconnected from the negative post on the coil.*

3. Crank engine through at least four compression strokes to obtain highest possible reading.
4. Check and record compression of each cylinder.
5. If one or more cylinders read low or uneven, inject about a tablespoon of engine oil on top of pistons in low reading cylinders (through spark plug port). Crank engine several times and recheck compression.
  - If compression comes up but does not necessarily reach normal, rings are worn.
  - If compression does not improve, valves are burned, sticking or not seating properly.
  - If two adjacent cylinders indicate low compression and injecting oil does not increase compression, the cause may be a head gasket

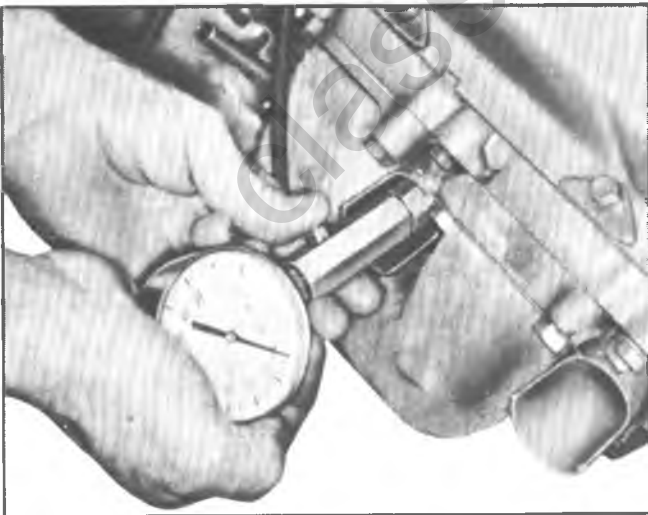

Fig. 1—Checking Compression

leak between the cylinders. Engine coolant and/or oil in cylinders could result from this defect.

**NOTE:** If a weak cylinder cannot be located with the compression check, see "Cylinder Balance Test" under "Additional Checks and Adjustments" in this section.

### SERVICE AND INSTALL SPARK PLUGS (FIG. 2)

1. Inspect each plug individually for badly worn electrodes, glazed, broken or blistered porcelains and replace plugs where necessary.
2. Clean serviceable spark plugs thoroughly, using an abrasive-type cleaner such as sand blast. File the center electrode flat.
3. Inspect each spark plug for make and heat range. All plugs must be of the same make and number.
4. Adjust spark plug gaps to specifications using a round feeler gauge.

**CAUTION:** *Never bend the center electrode to adjust gap. Always adjust by bending ground or side electrode.*

5. If available, test plugs with a spark plug tester.
6. Inspect spark plug hole threads and clean before installing plugs. Corrosion deposits can be removed with a 14 mm. x 1.25 SAE spark plug tap (available through local jobbers). (Use grease on tap to catch chips.)

**CAUTION:** *Use extreme care when using tap to prevent cross threading. Also crank engine several times to blow out any material dislodged during cleaning operation.*

7. Install spark plugs and torque to specifications.

**NOTE:** The following are some of the greatest causes of unsatisfactory spark plug performance.

- Installation of plugs with insufficient torque to fully seat.
  - Installation of the plugs using excessive torque which changes gap settings.
  - Installation of plugs on dirty seat.
  - Installation of plugs to corroded spark plug hole threads.
8. Connect spark plug wiring.

### SERVICE IGNITION SYSTEM

1. Remove distributor cap, clean cap and inspect for cracks, carbon tracks and burned or corroded terminals. Replace cap where necessary (fig. 3).
2. Clean rotor and inspect for damage or deterioration. Replace rotor where necessary.
3. Replace brittle, oil soaked or damaged spark plug wires. Install all wires to proper spark plug. Proper

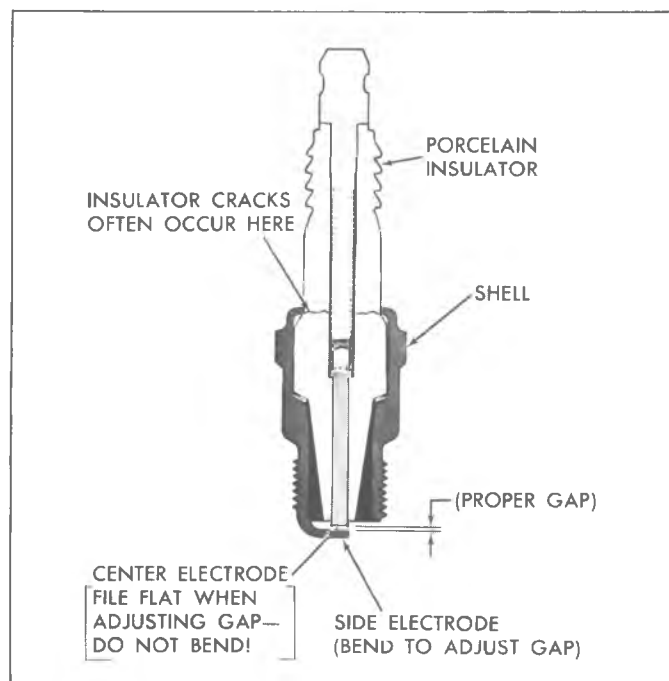

Fig. 2—Spark Plug Detail

positioning of spark plug wires in supports is important to prevent cross-firing.

4. Tighten all ignition system connections.
5. Replace or repair any wires that are frayed, loose or damaged.

### Distributor (Figs. 4 or 5)

1. Check the distributor centrifugal advance mechanism by turning the distributor rotor in a clockwise direction as far as possible, then releasing the rotor to see if the springs return it to their retarded position. If the rotor does not return readily, the distributor must be disassembled and the cause of the trouble corrected.
2. Check to see that the vacuum control operates freely by turning the movable breaker plate counterclockwise to see if the spring returns to its retarded position. Any stiffness in the operation of the vacuum control will affect the ignition timing. Correct any interference or binding condition noted.
3. Examine distributor points and clean or replace if necessary.
  - Contact points with an overall gray color and only slight roughness or pitting need not be replaced.
  - Dirty points should be cleaned with a clean point file.

Use only a few strokes of a clean, fine-cut contact file. The file should not be used on other metals and should not be allowed to become greasy or dirty. Never use emery cloth or sandpaper to clean contact

points since particles will embed and cause arcing and rapid burning of points. Do not attempt to remove all roughness nor dress the point surfaces down smooth. Merely remove scale or dirt.

- Clean cam lobe with cleaning solvent and rotate cam lubricator wick 180°.

NOTE: Where prematurely burned or badly pitted points are encountered, the ignition system and engine should be checked to determine the cause of trouble so that it can be eliminated. Unless the condition causing point burning or pitting is corrected, new points will provide no better service than the old points. Refer to Section 6Y for an analysis of point burning or pitting.

- Check point alignment (fig. 6) then, adjust distributor contact point gap to .019" (new points) or .016" (used points). Breaker arm rubbing block must be on high point of lobe during adjustment.

NOTE: If contact points have been in service, they should be cleaned with a point file before adjusting with a feeler gauge.

- Check distributor point spring tension (contact point pressure) with a spring gauge hooked to breaker lever at the contact and pull exerted at 90 degrees to the breaker lever. The points should be closed (cam follower between lobes) and the reading taken just as the points separate. If not within limits, replace.

Excessive point pressure will cause excessive wear on the points, cam and rubbing block. Weak point pressure permits bouncing or clattering, resulting in arcing and burning of the points and an ignition miss at high speed.

4. Install rotor and distributor cap. Press all wires firmly into cap towers.

### SERVICE BATTERY AND BATTERY CABLES

1. Measure the specific gravity of the electrolyte in each cell (fig. 7). If it is below 1.230 (corrected to 80°F.) recharge with a slow rate charger, or if desired, further check battery.
2. Connect a voltmeter across the battery terminals and measure the terminal voltage of the battery during cranking (disconnect the coil primary lead at the negative terminal during this check to prevent engine from firing). If the terminal voltage is less than 9.0 volts at room temperature, approximately 80° ± 20°F., the battery should be further checked. See Section 6Y for further tests.
3. Inspect for signs of corrosion on battery, cables and surrounding area, loose or broken carriers, cracked or bulged cases, dirt and acid, electrolyte leakage

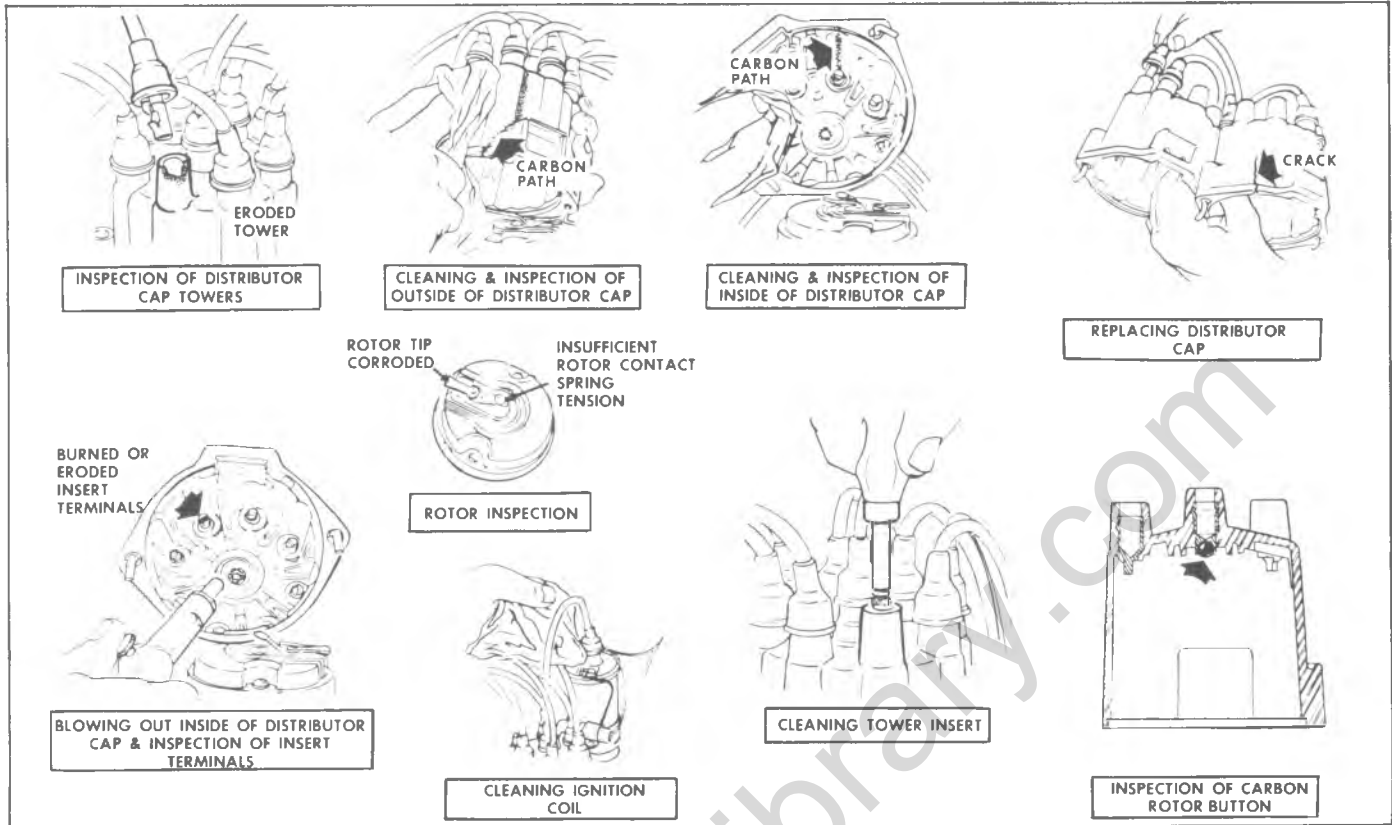

Fig. 3—Cleaning and Inspecting Distributor Cap, Rotor and Coil

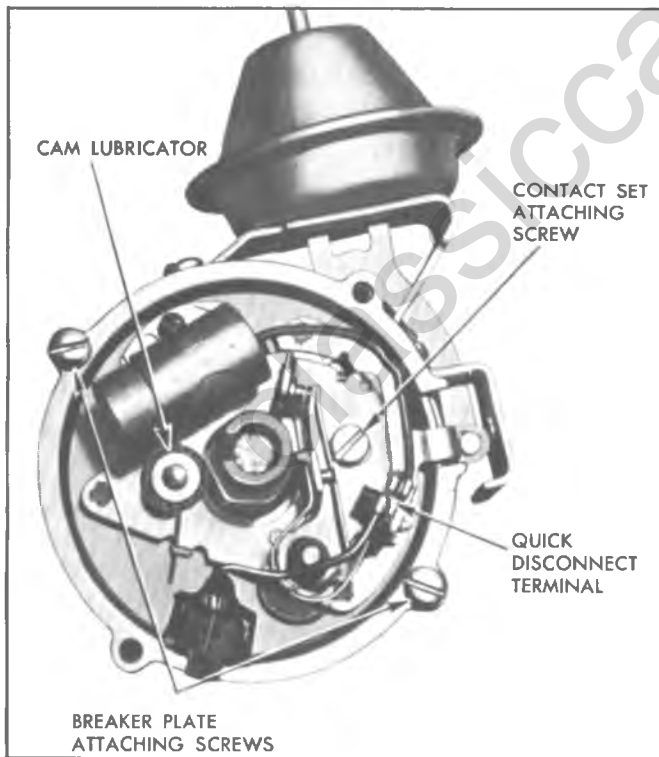

Fig. 4—Distributor (In Line)

and low electrolyte level. Fill cells to proper level with colorless, odorless, drinking water.

The top of the battery should be clean and the battery hold-down bolts properly tightened. Particular care should be taken to see that the top of the battery is kept clean of acid film and dirt. When cleaning batteries, wash first with a dilute ammonia or soda solution to neutralize any acid present and then flush off with clean water. Keep vent plugs tight so that the neutralizing solution does not enter the cell. The hold down bolts should be kept tight enough to prevent the battery from shaking around in its holder, but they should not be tightened to the point where the battery case will be placed under a severe strain.

To insure good contact, the battery cables should be tight on the battery. If the battery cable terminals are corroded, the cables should be cleaned separately with a soda solution and wire brush.

If the battery has remained undercharged, check for loose or defective fan belt, defective Delcotron, high resistance in the charging circuit, oxidized regulator contact points, or a low voltage setting.

If the battery has been using too much water, the voltage output is too high.

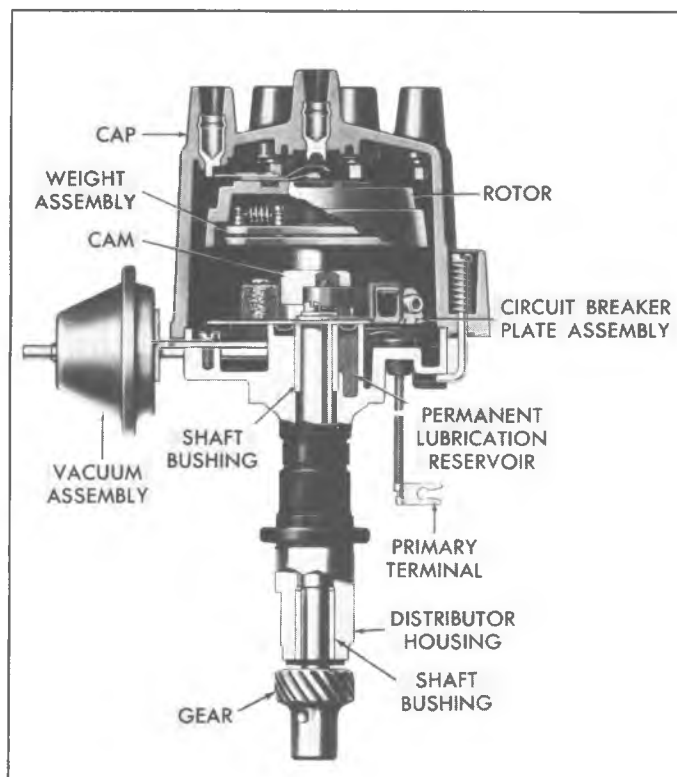

Fig. 5—Distributor (V8)

## SERVICE DELCOTRON AND REGULATOR

The Delcotron and regulator tests during tune up consist of the above battery tests; the condition of the battery will indicate the need for further tests and adjustments as outlined in Section 6Y.

## SERVICE BELTS (FIG. 8)

Inspect belt condition.

Check and adjust if necessary for correct tension of belt, as follows:

- Using a strand tension gauge, check the belt tension.
- If belt is below the minimum, adjust until the specified tension, is reached. (See Tune Up Chart in Specification section.)

## SERVICE MANIFOLD HEAT VALVE (FIG. 9 or 10)

Check manifold heat control valve for freedom of operation. If shaft is sticking, free it up with GM Manifold Heat Control Solvent or its equivalent.

NOTE: Tap shaft end to end to help free it up.

## TIGHTEN MANIFOLD

Tighten intake manifold bolts to specifications in the sequence outlined on Torque Sequence Chart located at end of Engine Mechanical section. A slight leak at the

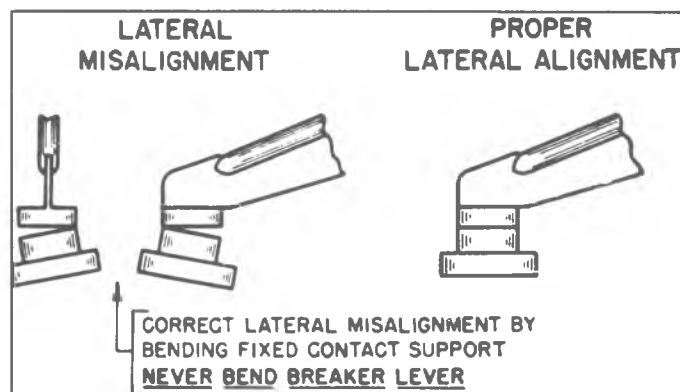

Fig. 6—Point Alignment

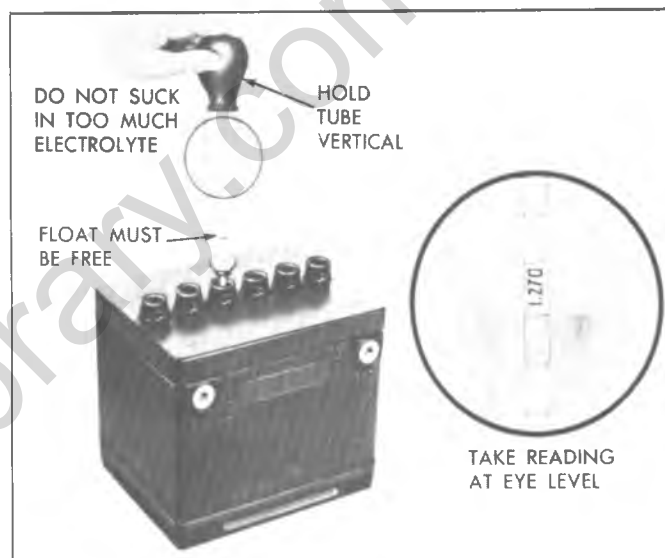

Fig. 7—Testing Specific Gravity of Battery

intake manifold destroys engine performance and economy.

## SERVICE FUEL LINES AND FUEL FILTER

1. Inspect fuel lines for kinks, bends or leaks and correct any defects found. Refer to Section 8 for the correct fabrication and replacement procedures for fuel lines.
2. Inspect filter and replace if plugged.

NOTE: If a complaint of poor high speed performance exists on the vehicle, fuel pump tests described in Section 6M should be performed.

## SERVICE COOLING SYSTEM

1. Inspect cooling system for leaks, weak hoses, loose hose clamps and correct coolant level, and service as required.

NOTE: A cooling system pressure test, as

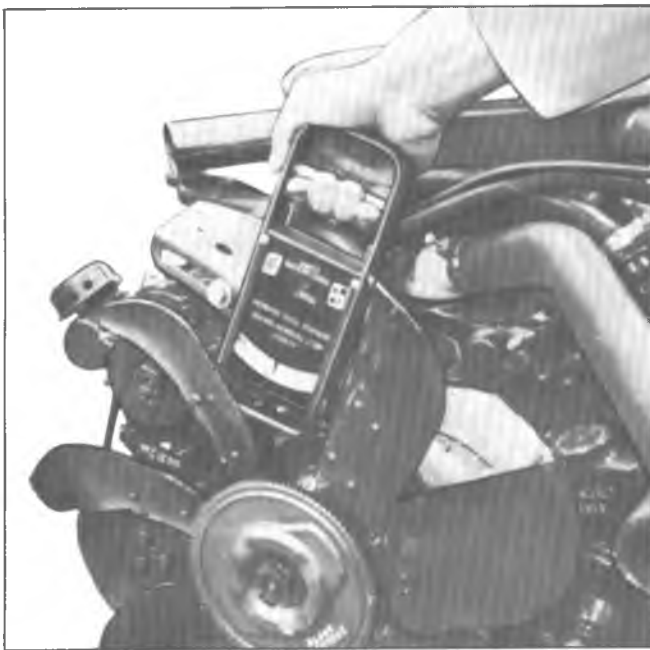

Fig. 8—Checking Fan Belt Tension

described in “Additional Checks and Adjustments” in this section, may be performed to detect internal or external leaks within the cooling system.

### SERVICE CRANKCASE VENTILATION (FIG. 11)

All engines have a “Closed Positive” ventilation system utilizing manifold vacuum to draw fumes and contaminating vapors into the combustion chamber where they are burned. Since it affects every part of the engine, crankcase ventilation is an important function and should be understood and serviced properly.

In a “Closed Positive” ventilation system, air is drawn through the engine crankcase (through a regulating valve) (fig. 12) into the manifold, drawing crankcase vapors and fumes with it to be burned. The “Closed Positive” ventilation system draws clean air from the carburetor air cleaner and has a nonvented oil filler cap.

1. Ventilation valve should be tested (using tester such as AC CT-3, or equivalent) and/or replaced at intervals specified in Section 0.
2. Inspect for deteriorated or plugged hoses.
3. Inspect all hose connections.
4. Remove flame arrestor and wash in solvent, then dry with compressed air.
5. Inspect ventilation filter (fig. 13) and replace if necessary.

### SERVICE AIR INJECTION REACTOR SYSTEM

Inspect air injection reactor system for evidence of leaks,

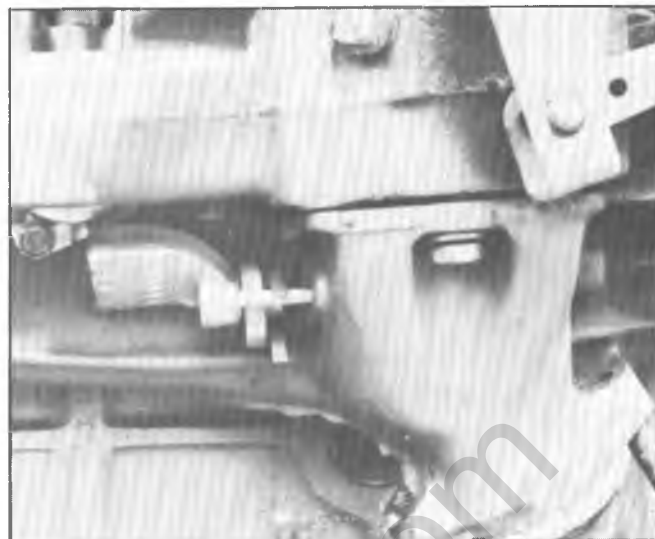

Fig. 9—Manifold Heat Control Valve (L6)

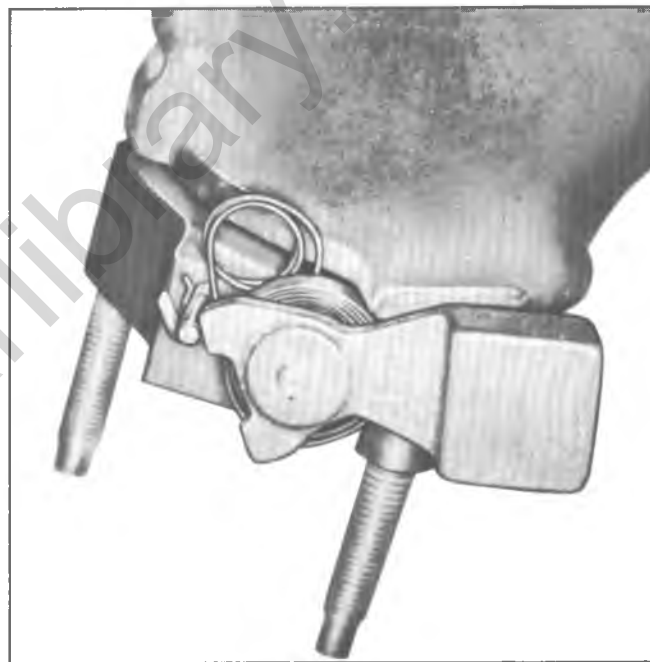

Fig. 10—Manifold Heat Control Valve (Typical V8)

deteriorated hoses, cracked air manifolds or tubes and loose hose clamps. Inspect air injection pump belt condition and tension. Make all necessary repairs as outlined in “Section 6T”.

Because of the relationship between “Engine Tune Up” and “Unburned Exhaust Gases”, the condition of Engine Tune Up should be checked whenever the Air Injection Reactor System seems to be malfunctioning. Particular care should be taken in checking items that affect fuel-air ration such as the crankcase ventilation system, the carburetor and the carburetor air cleaner. Carburetors and distributors for engines with the Air Injection Reactor System and Controlled Combustion System are



designed, particularly, for these engines; therefore, they must not be interchanged with or replaced by a carburetor or distributor designed for different applications.

### SERVICE EXHAUST GAS RECIRCULATION (EGR) VALVE

The valve should be removed and inspected at intervals

as specified in Section 0. Perform necessary service operations as specified in Section 6T.

### CHOKE ADJUSTMENT

Inspect choke valve, choke rod, choke coil and housing for proper alignment, bends and binding — make necessary corrections to assure proper choke operation; then adjust choke as outlined in Section 6M.

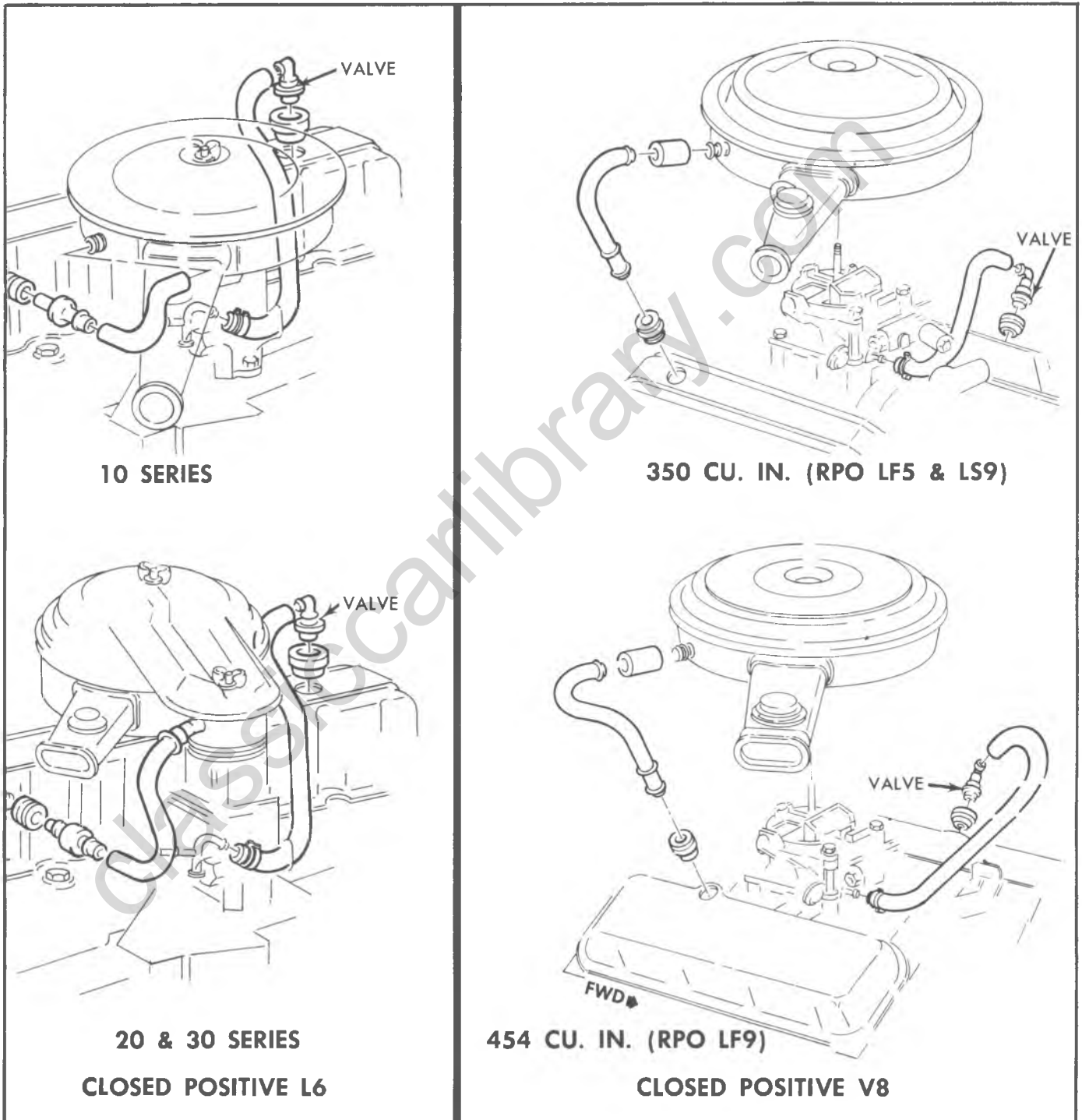

Fig. 11—Crankcase Ventilation Systems

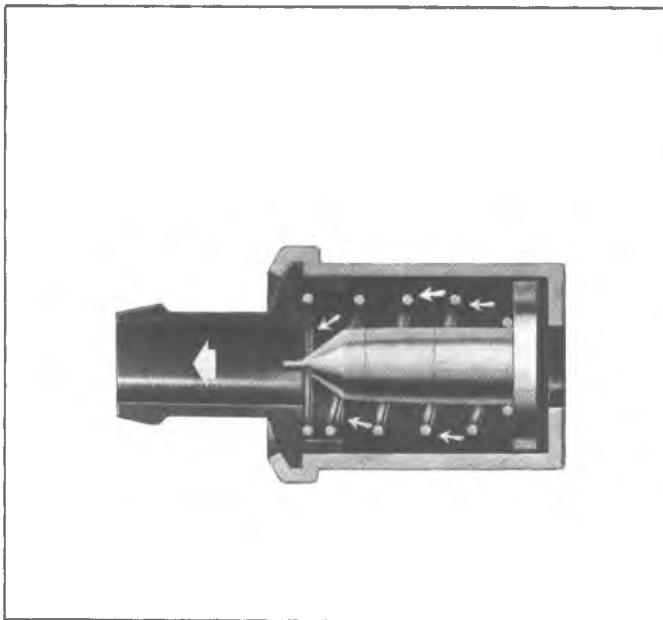

Fig. 12—Crankcase Ventilation Valve



Fig. 13—Crankcase Ventilation Filter

## INSTRUMENT CHECK-OUT

### INSTRUMENT HOOK-UP

Connect vacuum gauge, dwell meter, tachometer and timing light as recommended by the manufacturer of the equipment being used.

### CHECK AND ADJUST DWELL

1. Start engine then check ignition dwell.
2. If dwell is not within specifications, adjust dwell as follows:

### V8 Engine

- With engine running at idle, raise the adjustment screw window and insert an Allen wrench in the socket of the adjusting screw (fig. 14).
- Turn the adjusting screw as required until the specified dwell reading is obtained.
- Close access cover fully to prevent the entry of dirt into the distributor.

### In Line Engine

- Remove distributor cap and recheck point setting. If dwell is still not within specifications check the distributor as outlined in Section 6Y.

### CHECK DWELL VARIATION

Slowly accelerate engine to 1750 rpm and note dwell reading. Return engine to idle and note dwell reading. If dwell variation exceeds specifications, check for worn

distributor shaft, worn distributor shaft bushing or loose breaker plate.

### CHECK AND ADJUST IGNITION TIMING (FIG. 15)

1. Disconnect the distributor spark advance hose and plug the vacuum source opening.
2. Start engine and run at idle speed. (See tune up chart in Specification section.)
3. Aim timing light at timing tab.

NOTE: The markings on the tabs are in 2° increments (the greatest number of markings on the "Before" side of the "O"). The "O" marking is TDC and all BTDC settings fall on the "Before" (advance) side of "O".

4. Adjust the timing by loosening the distributor clamp and rotating the distributor body as required, then tighten the clamp and recheck timing.
5. Stop engine and remove timing light and reconnect the spark advance hose.

### ADJUST IDLE SPEED (FIG. 16)

Emission system requirements necessitate the division of the Series 10-30 trucks into two groups as follows:

- a. Light Duty Emission Vehicles - Includes all 10 Series; C-K20 Suburban Models; All G20 Series and G30 Sportvan Models.
- b. Heavy Duty Emission Vehicles - Includes all C-K-P20 Series (Except C-K20 Suburban Models); all

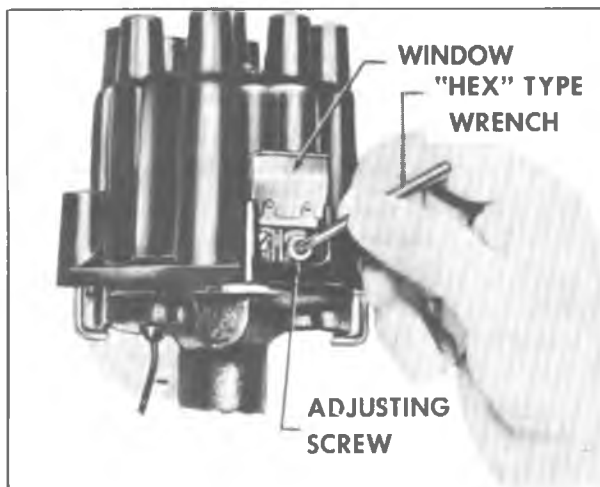

Fig. 14—Setting Point Dwell (Typical V8)

C-P30 Series and all G30 Series (Except Sportvan Models).

NOTE: Idle speed will increase as new engines loosen up during the first few hundred miles of operation. Idle speed should be reset during tune-up as specified in the following procedures.

With engine running at operating temperature, air cleaner installed, choke valve in fully open position, air

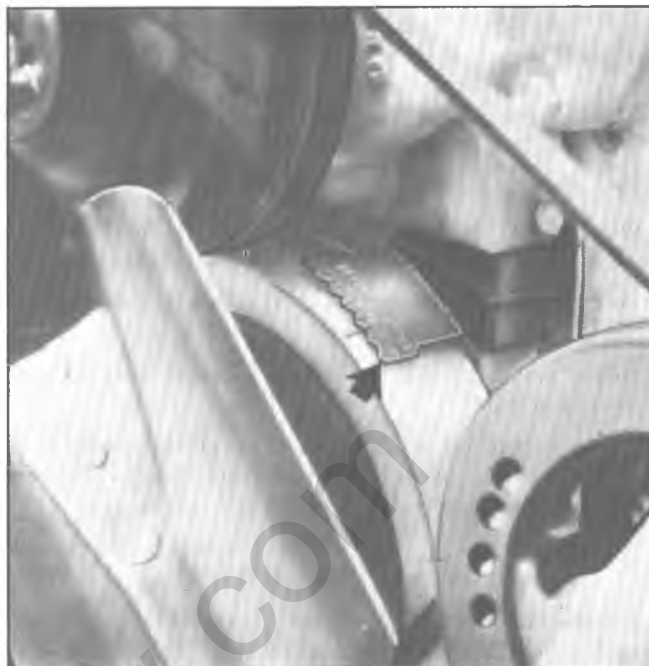

Fig. 15—Ignition Timing Marks

conditioning "off", parking brake on and drive wheels blocked - adjust idle speed as follows (See "Tune-up" Decal Figure 17.):

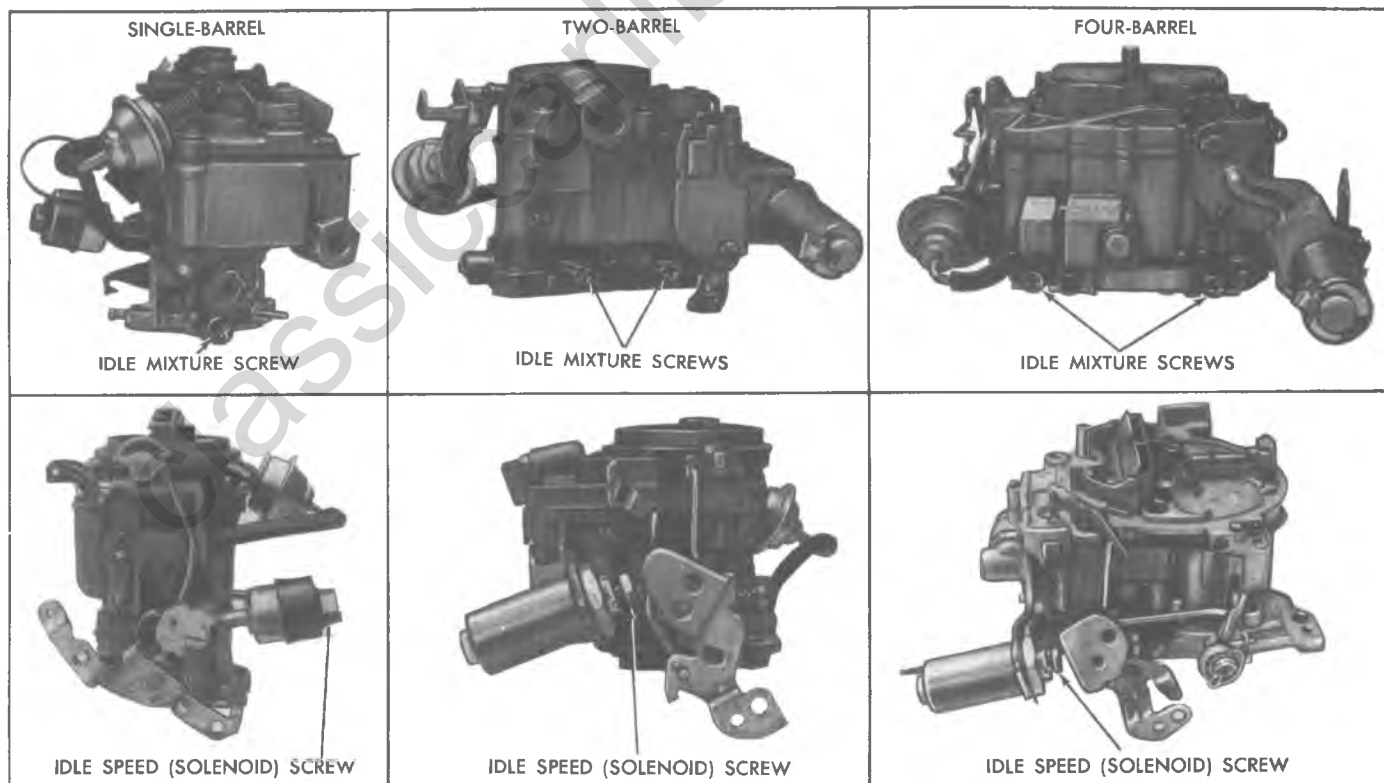

Fig. 16—Idle Speed and Mixture Screws

## 6-10 ENGINE

NOTE: All carburetors are equipped with idle mixture limiter caps (fig. 16). These caps permit limited adjustment (1/2 to 3/4 turn clockwise) to lean the idle mixture. Do not remove mixture screw caps.

### • 250 Cu. In. (Single-Barrel Carburetor)

On 250 cu. in. vehicles so equipped, disconnect "Fuel Tank" line from Evaporation Emission vapor canister.

Disconnect the distributor spark advance hose and plug the vacuum source opening.

Adjust Idle Stop Solenoid (turn solenoid body, using hex nut) to obtain:

600 rpm on all Heavy-Duty Vehicles and 850 rpm on all Light-Duty vehicles equipped with manual transmission (in neutral).

600 rpm on Light-Duty vehicles equipped with automatic transmissions (in "Park").

Place transmission in "park" or neutral and adjust carburetor fast idle speed to obtain 1800 rpm with cam follower on top step of cam.

Reconnect "Fuel Tank" line to vapor canister and reconnect distributor spark advance hose.

### • 292 Cu. In. (Single-Barrel Carburetor)

On vehicles so equipped, disconnect "Fuel Tank" line from evaporation Emission vapor canister.

Disconnect the distributor spark advance hose and plug the vacuum source opening.

Place transmission in neutral and adjust Idle Stop Solenoid (turn solenoid body, using hex nut) to obtain 600 rpm on all vehicles with automatic transmission in "Park" and manual transmission in neutral.

Reconnect "Fuel Tank" line to canister and reconnect distributor spark advance hose.

### • 350 Cu. In. (Four-Barrel Carburetor)

On vehicles so equipped, disconnect "Fuel Tank" line from Evaporation Emission vapor canister.

Disconnect the distributor spark advance hose and plug the vacuum source opening.

On Heavy-Duty vehicles, adjust carburetor Idle Stop Solenoid Screw to obtain 600 rpm with automatic transmission in "Park" and manual transmission in neutral.

On Light Duty vehicles, adjust Idle Stop Solenoid Screw to obtain 600 rpm with automatic transmission in Drive; 900 rpm with manual transmission in neutral.

On Light-Duty vehicles with automatic transmission, reconnect distributor spark advance hose. Adjust fast idle screw to obtain 1600 rpm with screw on top step of fast idle cam.

On Light-Duty vehicles with manual transmission, adjust fast idle screw to obtain 1300 rpm with screw on top step of fast idle cam and distributor spark advance hose disconnected.

Reconnect "Fuel Tank" line to vapor canister and reconnect distributor spark advance hose.

### • 454 Cu. In. (Four-Barrel Carburetor)

On vehicles so equipped, disconnect "Fuel Tank" line from Evaporation Emission vapor canister.

Disconnect the distributor spark advance hose and plug the vacuum source opening.

Adjust Idle Stop Solenoid Screw to obtain:

700 rpm on all Heavy Duty vehicles - automatic transmission in "Park"; manual transmission in neutral.

600 rpm on Light-Duty vehicles with automatic transmission (in Drive).

800 rpm on Light-Duty vehicles with manual transmission (in neutral).

On Light Duty vehicles with automatic transmission, reconnect distributor spark advance hose. Adjust fast idle screw to obtain 1600 rpm with screw on top step of fast idle cam.

On Light-Duty vehicles with manual transmission, adjust fast idle screw to obtain 1500 rpm with screw on top step of fast idle cam and distributor spark advance hose disconnected.

Reconnect "Fuel Tank" line to vapor canister and reconnect distributor spark advance hose.

XB		VEHICLE EMISSION CONTROL INFORMATION		AIR-GR EXHAUST EMISSION CONTROL		TRANSMISSION	
350 CU. IN. 4 BR. CARB GM 154		GENERAL MOTORS CORPORATION		GM		AUTOMATIC	MANUAL
MAKE IDLE SPEED AND TIMING ADJUSTMENTS WITH ENGINE AT NORMAL OPERATING TEMP. CHOKE OPEN, AIR COND. OFF, AIR CLEANER INSTALLED, AND DISTR. VACUUM LINE DISCONNECTED AND PLUGGED. RECONNECT DISTR. VACUUM LINE WHEN ADJUSTMENTS ARE COMPLETED. SET PARKING BRAKE AND BLOCK DRIVE WHEELS.							
1. DISCONNECT FUEL TANK HOSE FROM VAPOR CANISTER. 2. SET IDLE MIXTURE AND TIMING AT SPECIFIED RPM. 3. ADJUST CARBURETOR SOLENOID SCREW TO SPECIFIED RPM. 4. WITH TRANSMISSION IN PARK OR NEUTRAL, ADJUST FAST IDLE SCREW TO SPECIFIED SPEED ON TOP STEP OF CAM. VAC. SPARK CONN. FOR AUTO. TRANS. 5. RECONNECT FUEL TANK HOSE TO VAPOR CANISTER. 6. IDLE MIXTURE PRESET AT FACTORY. DO NOT REMOVE CAPS. 7. IF CARBURETOR IS REPAIRED OR IDLE MIXTURE SCREW CAPS HAVE BEEN REMOVED, RESET IDLE MIXTURE BY USING 1/2 TURN RICH FROM LEAN ROLL METHOD. INSTALL REPLACEMENT IDLE MIXTURE SCREW CAPS PROVIDED FROM DEALER. 8. REMOVAL OF MIXTURE SCREW CAPS AND ALTERING TO OTHER THAN SPECIFIED IDLE MIXTURE SETTING MAY VIOLATE FEDERAL AND/OR CALIFORNIA AND OTHER STATE LAWS.							
		TIMING (° BTDC @RPM)		12 @400		7 @900	
		SPARK PLUG-GAP		.015		.021	
		SOLENOID SCREW (RPM)		AUTO (IN DRIVE)		900	
		FAST IDLE SCREW (RPM)		1600		1300	
		IDLE MIXTURE SETTING		1/2 TURN RICH FROM LEAN ROLL			
		SEE OWNER'S MANUAL FOR ADDITIONAL INFORMATION					
		AUTO		MAN		T	
		1		2		3	
		4		5		6	
		7		8		9	
		10		11		12	
		13		14		15	
		16		17		18	
		19		20		21	
		22		23		24	
		25		26		27	
		28		29		30	
		31		32		33	
		34		35		36	
		37		38		39	
		40		41		42	
		43		44		45	
		46		47		48	
		49		50		51	
		52		53		54	
		55		56		57	
		58		59		60	
		61		62		63	
		64		65		66	
		67		68		69	
		70		71		72	
		73		74		75	
		76		77		78	
		79		80		81	
		82		83		84	
		85		86		87	
		88		89		90	
		91		92		93	
		94		95		96	
		97		98		99	
		100		101		102	
		103		104		105	
		106		107		108	
		109		110		111	
		112		113		114	
		115		116		117	
		118		119		120	
		121		122		123	
		124		125		126	
		127		128		129	
		130		131		132	
		133		134		135	
		136		137		138	
		139		140		141	
		142		143		144	
		145		146		147	
		148		149		150	
		151		152		153	
		154		155		156	
		157		158		159	
		160		161		162	
		163		164		165	
		166		167		168	
		169		170		171	
		172		173		174	
		175		176		177	
		178		179		180	
		181		182		183	
		184		185		186	
		187		188		189	
		190		191		192	
		193		194		195	
		196		197		198	
		199		200		201	
		202		203		204	
		205		206		207	
		208		209		210	
		211		212		213	
		214		215		216	
		217		218		219	
		220		221		222	
		223		224		225	
		226		227		228	
		229		230		231	
		232		233		234	
		235		236		237	
		238		239		240	
		241		242		243	
		244		245		246	
		247		248		249	
		250		251		252	
		253		254		255	
		256		257		258	
		259		260		261	
		262		263		264	
		265		266		267	
		268		269		270	
		271		272		273	
		274		275		276	
		277		278		279	
		280		281		282	
		283		284		285	
		286		287		288	
		289		290		291	
		292		293		294	
		295		296		297	
		298		299		300	
		301		302		303	
		304		305		306	
		307		308		309	
		310		311		312	
		313		314		315	
		316		317		318	
		319		320		321	
		322		323		324	
		325		326		327	
		328		329		330	
		331		332		333	
		334		335		336	
		337		338		339	
		340		341		342	
		343		344		345	
		346		347		348	
		349		350		351	
		352		353		354	
		355		356		357	
		358		359		360	
		361		362		363	
		364		365		366	
		367		368		369	
		370		371		372	
		373		374		375	
		376		377		378	
		379		380		381	
		382		383		384	
		385		386		387	
		388		389		390	
		391		392		393	
		394		395		396	
		397		398		399	
		400		401		402	
		403		404		405	
		406		407		408	
		409		410		411	
		412		413		414	
		415		416		417	
		418		419		420	
		421		422		423	
		424		425		426	
		427		428		429	
		430		431		432	
		433		434		435	
		436		437		438	
		439		440		441	
		442		443		444	
		445		446		447	
		448		449		450	
		451		452		453	
		454		455		456	
		457		458		459	
		460		461		462	
		463		464		465	
		466		467		468	
		469		470		471	
		472		473		474	
		475		476		477	
		478		479		480	
		481		482		483	
		484		485		486	
		487		488		489	
		490		491		492	
		493		494		495	
		496		497		498	
		499		500		501	
		502		503		504	
		505		506		507	
		508		509		510	
		511		512		513	
		514		515		516	
		517		518		519	
		520		521		522	
		523		524		525	
		526		527		528	
		529		530		531	
		532		533		534	
		535		536		537	
		538		539		540	
		541		542		543	
		544		545		546	
		547		548		549	
		550		551		552	
		553		554		555	
		556		557		558	
		559		560		561	
		562		563			

Before suspecting the carburetor as the cause of poor engine performance or rough idle, check ignition system including distributor, set ignition timing, check PCV system and compression pressures. Also, check all vacuum hoses and connections for leaks and carburetor attachment bolt torques.

The Federal Government has defined Light and Heavy Duty Vehicles for emission purposes as follows.

**Light Duty Vehicles:**

6000 lb. GVW or less or designed for transportation of persons and having a capacity of 12 or less.

C, K, P10 All

C, K20 Suburban

G10, 20 All

G30 Sportvan

**Heavy Duty Vehicles:**

More than 6000 lb. GVW or designed for transportation of persons and having a capacity of greater than 12.

C20, 30 All (except Suburban)

K20, All (except Suburban)

G30 Van

P20, 30 All

At 24,000 mile intervals for light duty vehicles and 12,000 mile intervals for heavy duty vehicles, or in case of major carburetor overhaul, or when poor idle quality exists after performing the checks in the previous paragraph, idle mixture may be adjusted. To properly set idle mixture to achieve the smoothest idle while maintaining emission levels within the standards prescribed by Federal Law, the following procedure must be followed:

1. Refer to Specifications for idle speed settings.
2. Set parking brake and block drive wheels.
3. Disconnect fuel tank vent hose from vapor canister, (All Light Duty and on Heavy Duty if equipped) and disconnect and plug distributor vacuum hose at vacuum advance unit.
4. With engine at normal operating temperature (not hot), air conditioning off, and air cleaner installed, place transmission selector in Drive for light duty and in Neutral for heavy duty (automatic transmission) or neutral (manual transmission).
5. Break off tab on mixture cap using a needle nose pliers.
6. Adjust idle RPM to the higher of the two idle speeds specified, with idle stop solenoid energized and extended (example 650/600). If not equipped with idle stop solenoid, set idle speed with speed screw.
7. Equally richen (turn out) mixture screws until maximum idle speed is achieved. Reset speed if necessary to the higher specified idle speed.

8. Equally lean (turn in) mixture screws until the lower specified idle speed is achieved (example 650/600).
9. Connect fuel tank vent hose and distributor vacuum advance hose.

## ALTERNATE IDLE MIXTURE ADJUSTMENT PROCEDURE

To be used only if reliable CO meter is available.

**NOTE:** CO Meter must be capable of low level, accurate readings. Meters with an accuracy of  $\pm 2\%$  of full scale reading and scale divisions of 0.2% CO, or less, will be suitable.

Idle mixture screws have been preset at the factory and capped. Do not remove caps.

Before suspecting the carburetor as the cause of poor engine performance or rough idle, check ignition system including distributor, set ignition timing, check PCV system, and compression pressures. Also, check all vacuum hoses and connections for leaks and check carburetor attachment bolt torques.

At 24,000 mile intervals for light duty vehicles and 12,000 mile intervals for heavy duty vehicles, or in the case of high idle CO, major carburetor overhaul, or when poor idle quality exists after performing the checks in the previous paragraph, idle mixture may be adjusted. To properly set idle mixture to achieve the smoothest idle while maintaining emission levels within the standards prescribed by Federal Law, the following procedure **MUST** be followed:

1. Refer to Specifications for idle CO values.
2. Set parking brake and block drive wheels.
3. Disconnect fuel tank vent hose from vapor canister (all light duty and on heavy duty if equipped) and disconnect and plug distributor vacuum hose at vacuum advance unit.
4. With engine at normal operating temperature (not hot), air conditioning off and air cleaner installed, place transmission selector in Drive for light duty vehicles and Neutral for heavy duty vehicles (automatic transmission) or Neutral (manual transmission).
5. Connect CO meter to exhaust system tailpipe.
6. Set curb idle speed to specified RPM with idle stop solenoid energized and extended. (If not equipped with idle stop solenoid, set idle speed with speed screw).
7. Record idle CO. If idle CO exceeds value shown in Specifications, proceed as follows. If idle CO is within limits and engine idles smoothly, no further adjustment is required.
8. Turn each idle mixture cap (clockwise) in equal amounts until idle CO is at or below percent shown in Specifications. **DO NOT REMOVE CAPS.** Reset idle speed if necessary, with air cleaner in place.

9. Connect fuel tank vent hose and distributor vacuum advance hose.

## ADDITIONAL CHECKS AND ADJUSTMENTS

### CYLINDER BALANCE TEST (FIG. 18)

It is often difficult to locate a weak cylinder. A compression test, for example, will not locate a leaky intake manifold, a valve not opening properly due to a worn camshaft, or a defective spark plug.

With the cylinder balance test, the power output of one cylinder may be checked against another, using a set of grounding leads. When the power output of each cylinder is not equal, the engine will lose power and run roughly.

Perform a cylinder balance test as follows:

1. Connect the tachometer and vacuum gauge.
2. Start engine and run at 1500 rpm.
3. Ground large clip of grounding leads and connect individual leads to all spark plugs except the pair being tested.

Divide the firing order in half and arrange one half over the other. The cylinders to be tested together appear one over the other.

#### L6 Firing Order

$$1-5-3-6-2-4 = 1-5-3 = 1-6, 5-2, 3-4 \\ 6-2-4$$

#### V8 Firing Order

$$1-8-4-3-6-5-7-2 = 1-8-4-3 = 1-6, 8-5, 4-7, 3-2 \\ 6-5-7-2$$

4. Operate engine on each pair of cylinders in turn and note engine rpm and manifold vacuum for

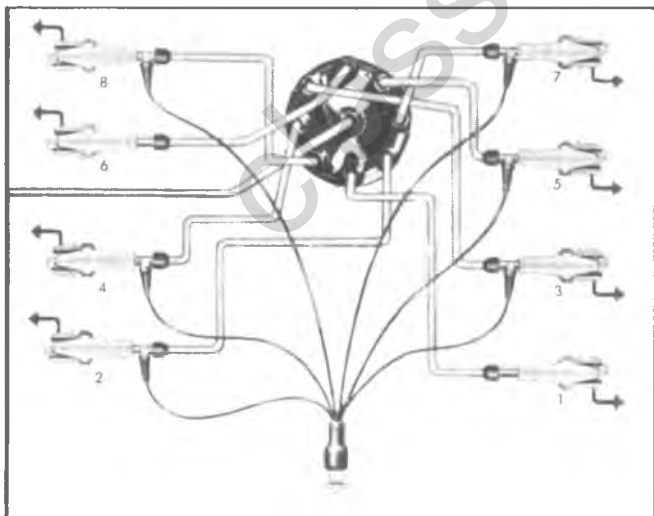

Fig. 18—Cylinder Balance Test

each pair. A variation of more than 1 inch of vacuum or 40 rpm between pairs of cylinders being tested indicates that the cylinders are off balance.

### BATTERY

The battery should be checked with special testing equipment and to the equipment manufacturers specifications. See Section 6Y for complete information on battery tests.

### IGNITION

The following additional ignition checks may be made with any of several pieces of equipment available for uncovering the source of engine difficulties. The specific operating instructions of the equipment manufacturer should be followed.

- Cranking voltage
- Ignition switch
- Distributor resistance
- Secondary resistance
- Ignition output and secondary leakage

#### Cranking Voltage (Fig. 19)

1. Disconnect coil primary lead at the coil negative terminal to prevent engine from firing during cranking.
2. Connect voltmeter between primary terminal of coil (resistance wire side) and ground.
3. Operate starting motor.
  - a. If voltage is 9 volts or more and cranking speed is satisfactory, the battery, starter, cables, starter switch and ignition circuit to coil (by-passing resistance wire) are in good condition.
  - b. If below 9 volts, check circuit until difficulty is located.

**Meter reading below specification**—Weak battery; defective cables, connections, switch or starter; defective ignition circuit to coil.

**Cranking speed below normal**—Excessive resistance in cables or starting motor; excessive mechanical drag in engine.

**Uneven cranking speed**—Uneven compression, defective starter to starter drive.

#### Ignition Switch

With voltmeter connected as described for the Cranking Voltage Test, turn ignition switch to ON. Voltage should drop to 5 to 7 volts as current is now passing through high resistance wire connected between ignition switch

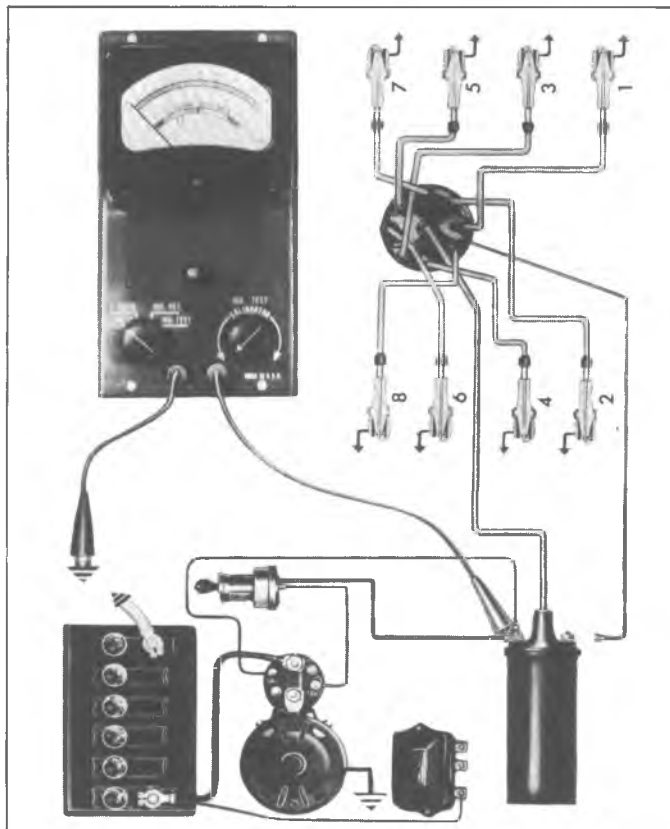

Fig. 19—Testing Cranking Voltage

and (+) positive terminal of coil. If battery voltage of 12 volts is obtained, the starter solenoid is by-passing the high resistance wire connected between ignition switch and (+) positive terminal of coil, thus the starter solenoid is not functioning properly to by-pass the ignition resistance wire or the ignition circuit is incorrectly wired.

NOTE: The voltage drop (12 to 5-7 volts) will only take place when the points are closed. If the points are open, the path through the resistance wire will not be completed.

### Distributor Resistance

Use equipment as directed by manufacturer. Excessive resistance in primary circuit must be eliminated before continuing with test procedure.

### Secondary Resistance

Use equipment as directed by manufacturer.

- Uniform "normal readings" as specified by manufacturer indicate all secondary circuit components are in good condition.
- If all readings are "below normal", check for corroded coil tower terminal, poorly connected or broken coil wire, center cap electrode or rotor tip burned, or an open secondary in coil.
- If readings are "higher than normal" at two or



Fig. 20—Cooling System Pressure Check

more plugs adjacent in firing order, cross firing is occurring in distributor cap or between spark plug cables concerned.

- If meter reads off scale to left, the coil polarity is reversed. Check for reversed coil primary wires, wrong coil or reversed vehicle battery connections.

### Ignition Output and Secondary Leakage

Use equipment as directed by manufacturer.

- GOOD readings indicate both ignition output and secondary insulation are good.
- If all readings are BAD or if ignition test calibrator cannot be adjusted to Set Line, check for high resistance in primary circuit, defective distributor points, coil or condenser.
- If readings are BAD when certain plug wires are lifted off, check for cracks or carbon tracks in distributor cap or defective insulation on those plug wires being lifted off.

## CARBURETOR

Refer to Section 6M to perform adjustments such as float level, pump rod and vacuum break.

## FUEL PUMP

If the owner has complained of poor high speed performance, the fuel pump may be at fault. Too low a pump pressure or volume will cause a high speed "miss" because of lack of fuel delivered to the carburetor, while too high a pressure will cause carburetor flooding. Check fuel pump as outlined in Section 6M.

## COOLING SYSTEM

The following test may be performed with pressure testing equipment available commercially for this purpose. This test provides an excellent means of detecting internal or external leaks within the cooling system.

1. Remove radiator cap.
2. Apply a test pressure of 3 pounds higher than the radiator cap (fig. 20), i.e. 18 pounds for a 15 pound cap.
3. If the pressure will not hold, there is either an internal or external leak in the system.

## CYLINDER HEAD TORQUE AND VALVE ADJUSTMENT

Retorquing the cylinder head bolts is not necessary unless a gasket has been replaced, or a leak is suspected. Valve lash must always be adjusted after the head has been torqued.

### Valve Adjustment

1. Remove rocker arm cover(s) and gasket(s).

**CAUTION:** Do not pry rocker arm cover loose. Gaskets adhering to cylinder head and rocker arm cover may be sheared by bumping end of rocker arm cover rearward with palm of hand or a rubber mallet.

2. Adjust valves on L-6 engines as follows:
  - a. Mark distributor housing, with chalk, at number one and number six positions (plug wire) then disconnect plug wires at spark plugs and coil and remove distributor cap and plug wire assembly (if not previously done).
  - b. Crank engine until distributor rotor points to number one cylinder position and breaker points are open. The following valves can be adjusted with engine in number one firing position:
    - Number one cylinder-Exhaust and Intake
    - Number two cylinder-Intake
    - Number three cylinder-Exhaust
    - Number four cylinder-Intake
    - Number five cylinder-Exhaust
  - c. Back out adjusting nut until lash is felt at the push rod then turn in adjusting nut until all lash is removed. This can be determined by checking push rod end play while turning adjusting nut (fig. 21). When play has been removed, turn adjusting nut in one full additional turn (to center lifter plunger).
  - d. Crank engine until distributor rotor points to number six position and breaker points are open.

The following valves can be adjusted with engine in number six firing position:

- Number two cylinder-Exhaust
- Number three cylinder-Intake
- Number four cylinder-Exhaust
- Number five cylinder-Intake
- Number six cylinder-Intake and Exhaust

3. Adjust valves on V-8 engines using the following procedures:
  - a. Crank engine until mark on torsional damper lines up with center or "0" mark on the timing tab and the engine is in the number 1 firing position. This may be determined by placing fingers on the number 1 cylinder valve as the mark on the damper comes near the "0" mark on the front cover. If the valves are not moving, the engine is in the number 1 firing position. If the valves move as the mark comes up to the timing tab, the engine is in number 6 firing position and crankshaft should be rotated one more revolution to reach the number 1 position.
  - b. Valve adjustment is made by backing off the adjusting nut (rocker arm stud nut) until there is play in the push rod and then tighten nut to just remove all push rod to rocker arm clearance. This may be determined by rotating push rod with fingers as the nut is tightened (fig. 22). When push rod does not readily move in relation to the rocker arm, the clearance has been eliminated. The adjusting nut should then be tightened an additional 1 turn to place the



Fig. 21—Valve Adjustment (L6 Engine)



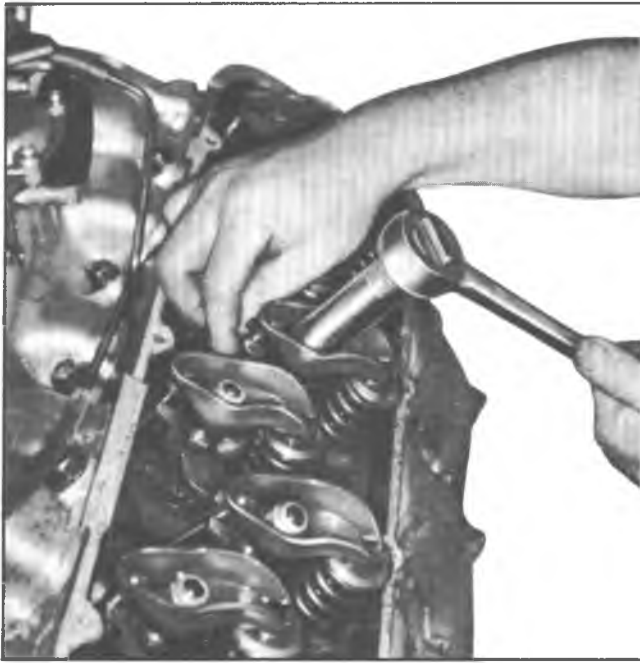

Fig. 22—Valve Adjustment (V8 Engine)

- hydraulic lifter plunger in the center of its travel. No other adjustment is required.
- c. With the engine in the number 1 firing position as determined above, the following valves may be adjusted.

Exhaust - 1, 3, 4, 8

Intake - 1, 2, 5, 7

- d. Crank the engine one revolution until the pointer "0" mark and torsional damper mark are again in alignment. This is number 6 firing position. With the engine in this position the following valves may be adjusted.

Exhaust - 2, 5, 6, 7

Intake - 3, 4, 6, 8

4. Clean gasket surfaces on cylinder head(s) and rocker arm cover(s) with degreaser, then install rocker arm cover(s), using new gasket(s), and torque bolts to specifications.
5. Install distributor cap and spark plug wire assembly.
6. Install rocker arm cover as outlined.
7. Adjust carburetor idle speed.

## THEORY OF OPERATION

All engines operate on the 4-stroke cycle principle (Fig. 1D and 2D). During this cycle the piston travels the length of its stroke four times. As the piston travels the length of its stroke (up or down) the crankshaft is rotated halfway (180 degrees). To accomplish one cycle of the 4-stroke cycle, the crankshaft rotates two complete turns; the camshaft, which controls the valves, is driven by the crankshaft at half crankshaft speed. Valve action, intake and exhaust, occurs once in each 4-stroke cycle and the piston acts as an air pump during the two remaining strokes.

### Intake Stroke

The intake valve is opened as the piston moves down in the cylinder (Fig. 3D). The piston traveling downward in the cylinder creates an area of pressure lower than that of the atmosphere surrounding the engine. Atmospheric pressure will cause air to flow into this low pressure area. By directing the air flow through the carburetor, a measured amount of vaporized fuel is added. When the piston reaches the bottom of the intake stroke, the cylinder is filled with air and vaporized fuel. The exhaust valve is closed during the intake stroke.

### Compression Stroke

When the piston starts to move upward, the compression stroke begins (Fig. 4D). The intake valve closes, trapping the air-fuel mixture in the cylinder. The upward movement of the piston compresses the mixture to a fraction of its original volume; exact pressure depends

principally on the amount of carburetor throttle opening and also on the compression ratio of the engine.

### Power Stroke

The power stroke is produced by igniting the compressed air-fuel mixture. When the spark plug arcs, an explosion does not occur. Instead, the mixture ignites and burns very rapidly during the power stroke. The extremely high temperature expands the gases, creating a very high pressure on the top of the piston which drives the piston down. This downward motion of the piston is transmitted through the connecting rod and is converted to rotary motion by the crankshaft. Both the intake and exhaust valves are closed during the power stroke (Fig. 5D).

### Exhaust Stroke

The exhaust valve opens just before the piston completes the power stroke (Fig. 6D). Pressure in the cylinder at this time causes the exhaust gas to rush into the exhaust manifold. The upward movement of the piston on its exhaust stroke expels most of the remaining exhaust gas.

As the piston pauses momentarily at the top of the exhaust stroke, the inertia of the exhaust gas tends to remove any remaining gas in the combustion chamber; however, a small amount of exhaust gas always remains to be mixed with the incoming mixture - this unexpelled gas is captured in the clearance area between the piston and the cylinder head.

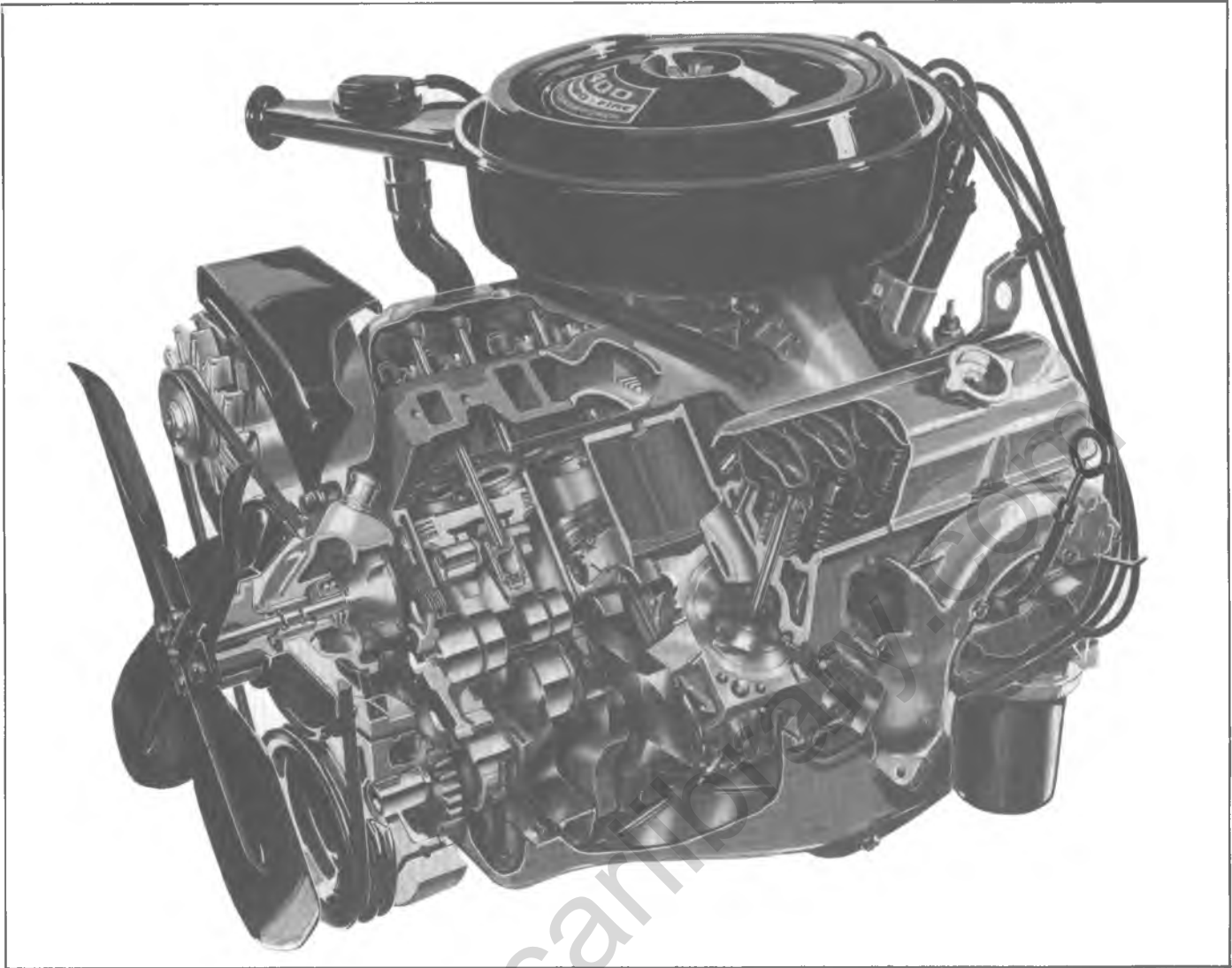

Fig. 1D—Sectional View of Eight-Cylinder Engine

## Combustion

The power delivered from the piston to the crankshaft is the result of a pressure increase in the gas mixture above the piston. This pressure increase occurs as the mixture is heated, first by compression, and then -- on the down stroke -- by burning. The burning fuel supplies heat that raises temperature and at the same time also raises pressure. Actually, about 75 per cent of the mixture in the cylinder is composed of nitrogen gas that does not burn but expands when heated by the burning of the combustible elements, and this expanding nitrogen supplies most of the pressure on the piston.

The fuel and oxygen must burn smoothly within the combustion chamber to take full advantage of this heating effect. Maximum power would not be delivered to the piston if an explosion took place, because the entire force would be spent in one sharp hammer-like blow, occurring too fast for the piston to follow.

Instead, burning must take place evenly as the flame moves across the combustion chamber. Burning must be

completed by the time the piston is about half-way down so that maximum pressure will be developed in the cylinder at the time the piston sends its greatest force to the crankshaft. This will be when the mechanical advantage of the connecting rod and crankshaft is at a maximum.

At the beginning of the power stroke, as the piston is driven downward by this pressure the volume above the piston increases, which would normally allow the pressure in the cylinder to drop. However, the combustion process is still occurring and this continues to raise the temperature of the gases, expanding them and maintaining a continuous pressure on the piston as it travels downward. This provides a smooth application of power throughout the effective part of the power stroke to make the most efficient use of the energy released by the burning fuel.

An internal combustion engine actually runs on heated air, the air being composed mainly of inert nitrogen. The fuel is used, not to cause explosions, but to cause

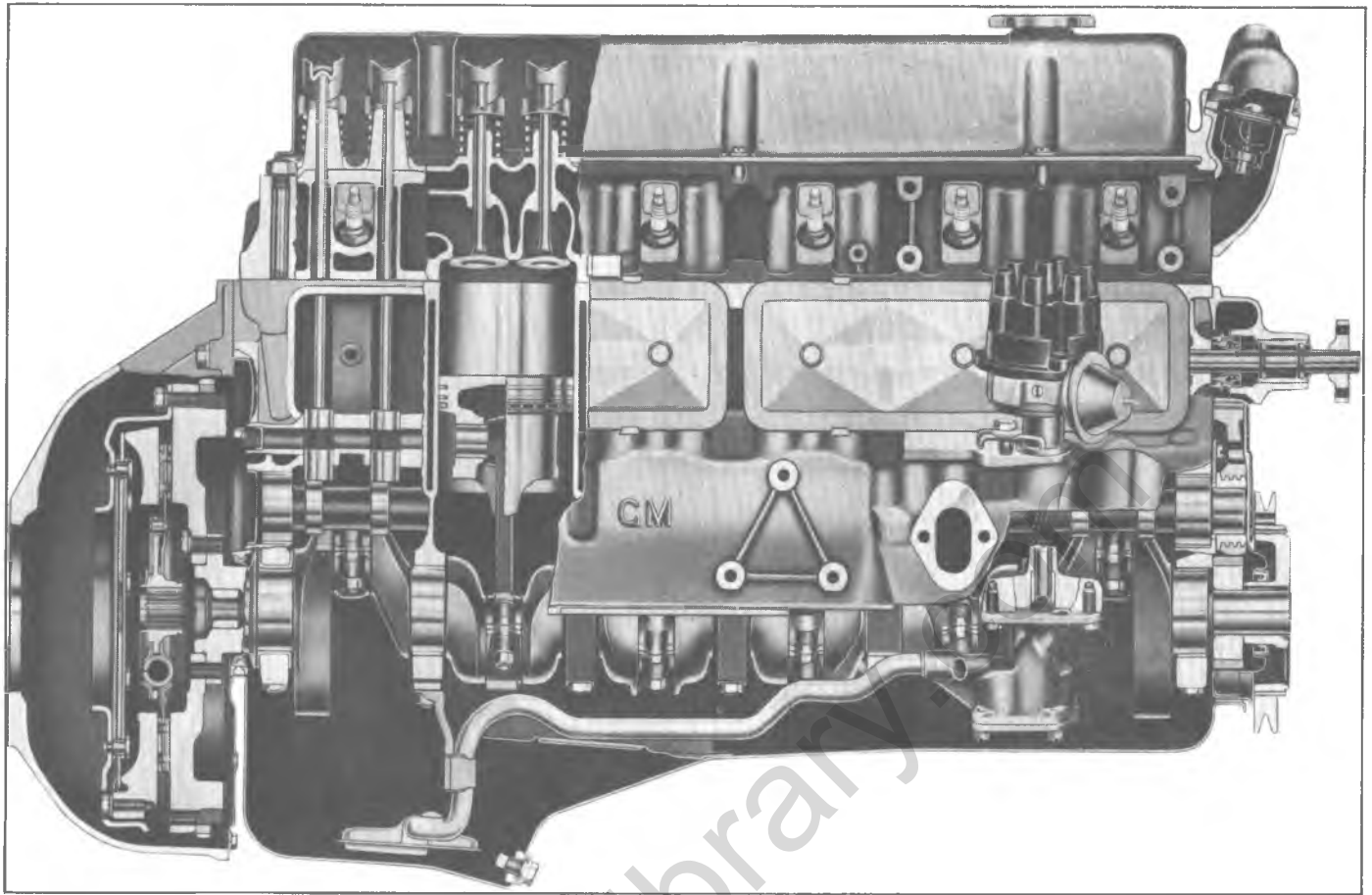

Fig. 2D—Sectional View of Six-Cylinder Engine

high pressure within the cylinder to push the piston down smoothly during the power stroke.

### Compression Ratio

The compression ratio is a comparison of the volume of the cylinder and combustion chamber when the piston is all the way down, to the volume remaining when the piston is all the way up.

The main advantage of a **high** compression ratio is that it enables the engine to develop more power from a given charge of fuel. The combustion pressure exerted downward on the piston is always 3 or 4 times as great as the compression pressure. Consequently, an increase in compression pressure (input) means at least three times as great an increase in combustion pressure (output).

### Valve Timing

As in most 4-stroke cycle engines, the intake valve begins to open before the piston reaches the top, and the exhaust valve remains open until after top dead center. This means that both valves are open for a short period of time. This condition is called valve overlap (Fig. 7D). The valve timing is arranged this way to use the inertia of the gas in evacuating and in filling the cylinders.

When the air-fuel mixture and exhaust gases move in or out of the cylinder, its weight gives it momentum in the established direction. When a valve opens, the initial air

flow is slow. Valve timing allows for this lag in starting and stopping in the flow. In order to pack the maximum air-fuel mixture into the cylinder, each valve opens earlier and closes later than would be necessary if the mixture were weightless.

On the intake stroke, the exhaust valve stays open a little after top center to take advantage of the momentum of the exhaust gases rushing out through the valve, even though the piston has started down. With the exhaust valve still open, the cylinder continues to empty itself because of this momentum.

On the compression stroke, the intake valve stays open past bottom center because incoming gases will continue to pack their way in for a short time after the piston reverses direction, due to their momentum.

On the power stroke, the exhaust valve opens before bottom center to get the exhaust gases started out of the cylinder.

On the exhaust stroke, the intake valve opens before top center to start the air fuel mixture moving into the cylinder.

Valve timing is not variable with speed and load as is ignition timing. Except for very small variations due to the stack of tolerances in the valve train (Fig. 8D), valves always open and close at the same time in the cycle. There is, however, one particular speed for a given engine at which the air-fuel mixture will pack itself into

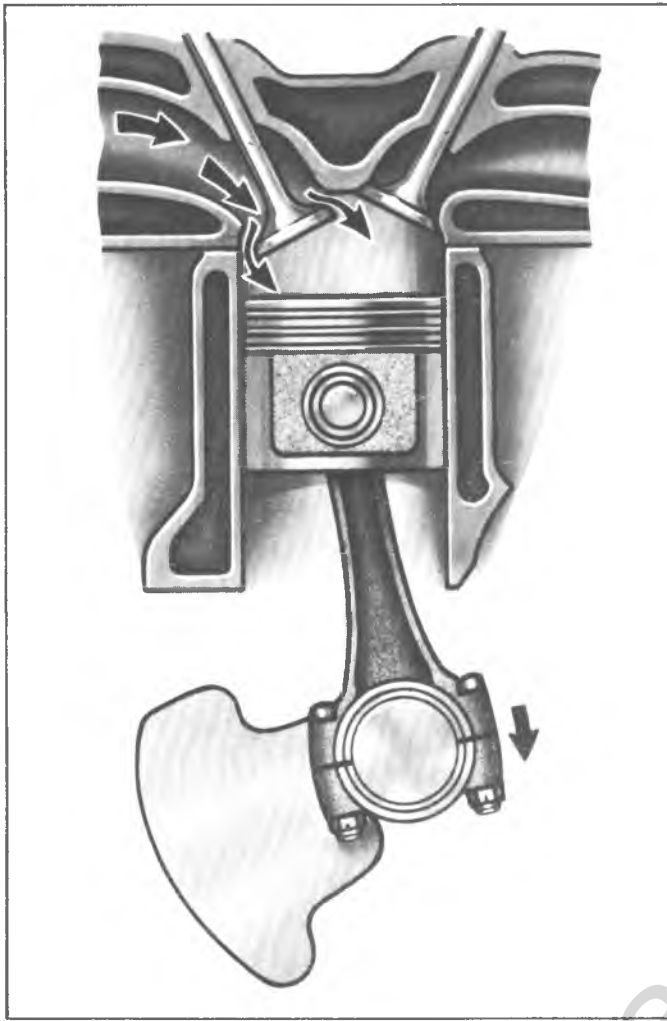

Fig. 3D—Piston Intake Stroke

the cylinders most effectively. This is the speed at which the engine puts out its peak torque. At low engine speeds, compression is somewhat suppressed due to the slight reverse flow through the valves just as they open or

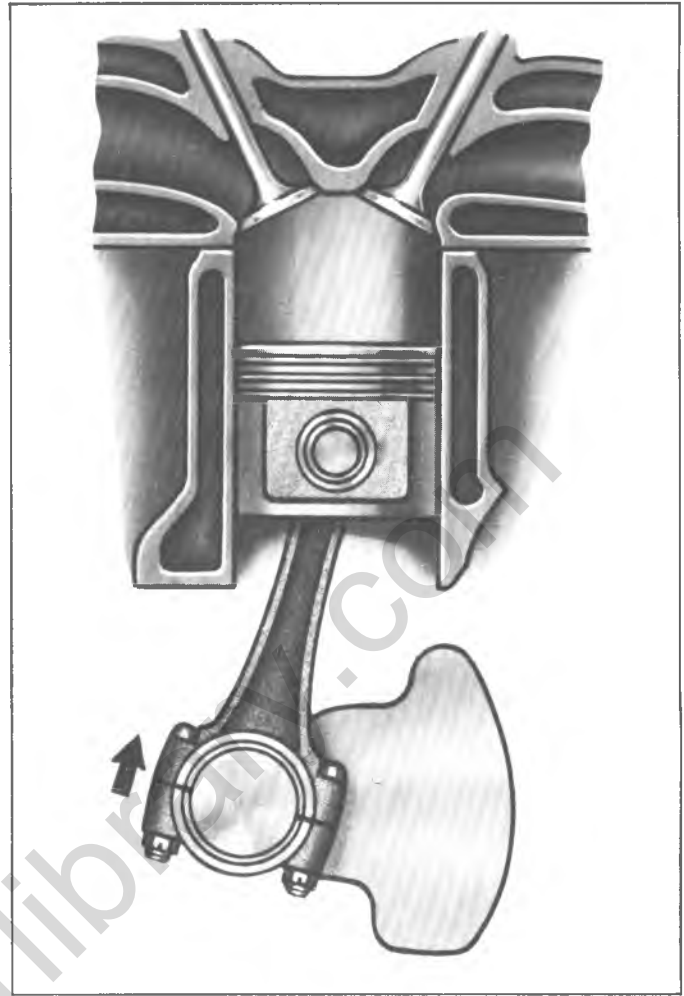

Fig. 4D—Piston Compression Stroke

close, when the mixture is not moving fast enough to take advantage of the time lag. At very high speeds, the valve timing does not allow quite enough time during the opening and closing periods for effective packing of the air-fuel mixture into the cylinders.

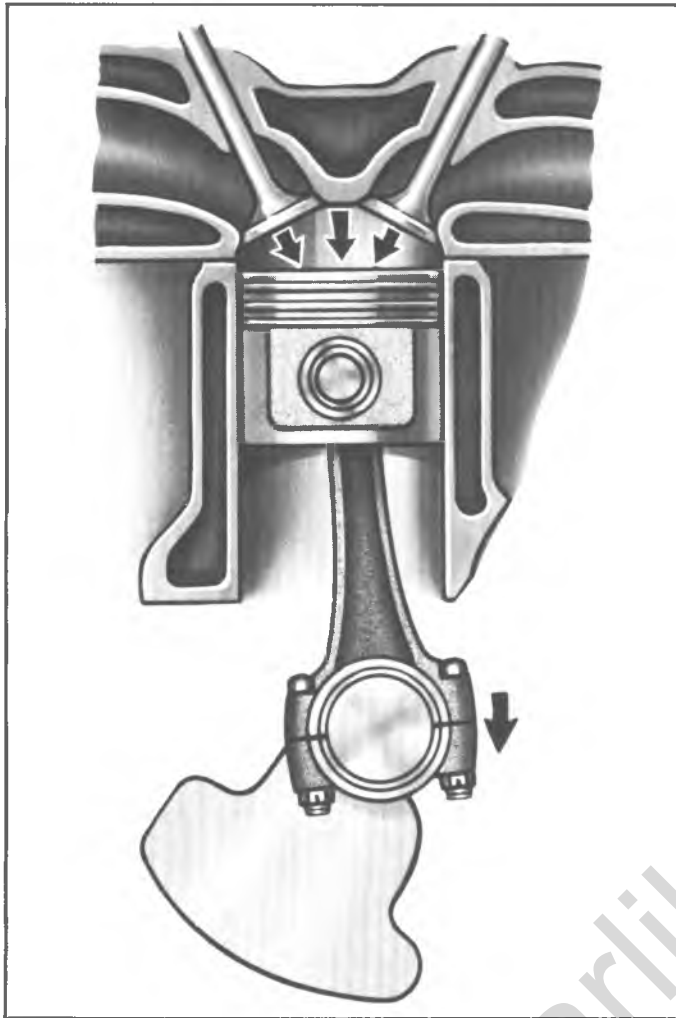

Fig. 5D—Piston Power Stroke

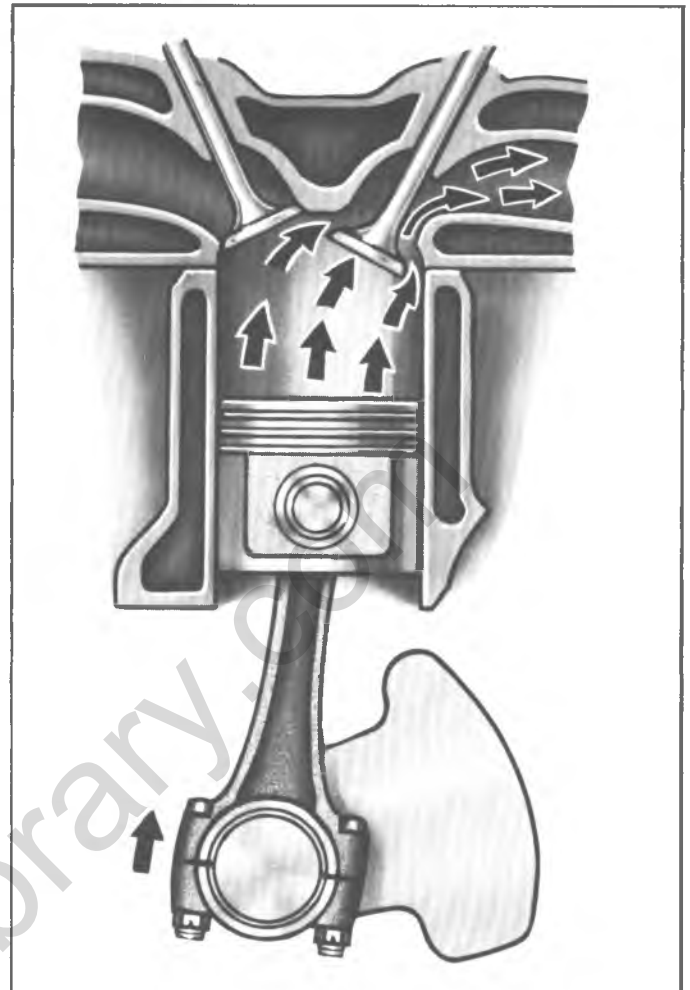

Fig. 6D—Piston Exhaust Stroke

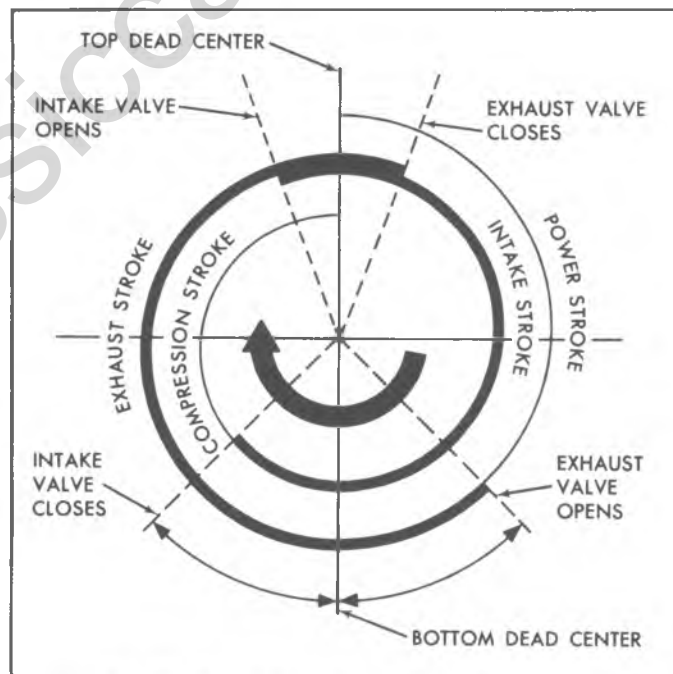

Fig. 7D—Typical Valve Overlap (720-degree spiral)

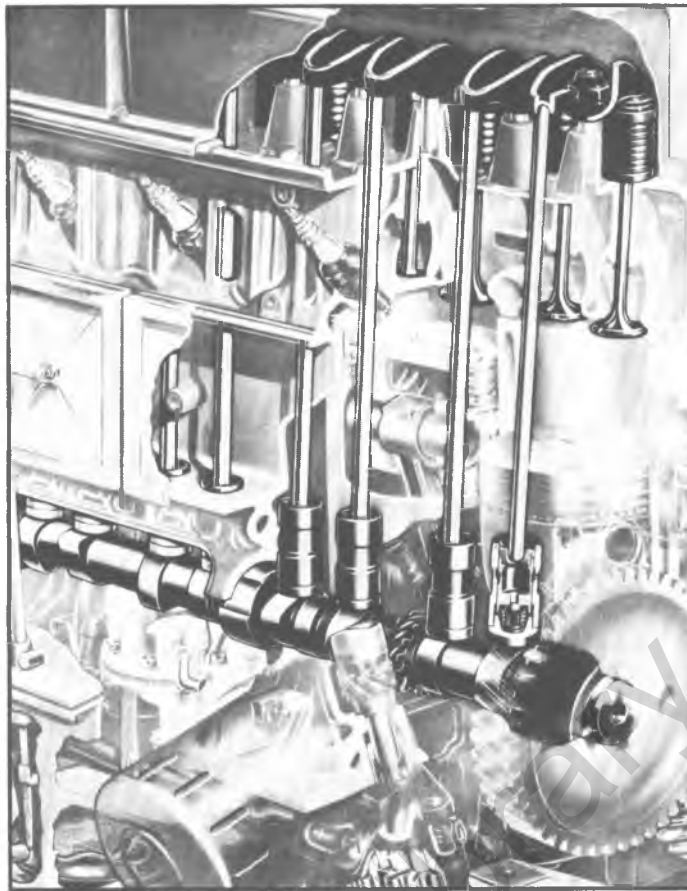

Fig. 8D—Valve System Components

## ENGINE MECHANICAL

### IN-LINE ENGINES

#### INDEX

General Description .....	6-21	Installation and Adjustment.....	6-27
Component Replacement and Adjustment.....	6-21	Valve Lifters.....	6-27
Engine Assembly.....	6-21	Locating Noisy Lifters .....	6-27
Removal (C, K and P Series).....	6-21	Removal.....	6-28
Removal (G Series).....	6-23	Installation .....	6-28
Installation (C, K and P Series) .....	6-24	Valve Stem Oil Seal and/or Valve Spring.....	6-28
Installation (G Series) .....	6-25	Replacement .....	6-28
Manifold Assembly.....	6-26	Cylinder Head Assemblies.....	6-28
Removal.....	6-26	Removal.....	6-28
Installation .....	6-26	Installation .....	6-29
Rocker Arm Cover .....	6-26	Oil Pan .....	6-29
Removal.....	6-26	Removal.....	6-29
Installation .....	6-26	Installation .....	6-29
Valve Mechanism .....	6-27	Oil Pump.....	6-29
Removal.....	6-27	Removal.....	6-29

Installation .....	6-29	Measuring Lobe Lift .....	6-33
Oil Seal (Rear Main) .....	6-30	Removal .....	6-34
Replacement .....	6-30	Installation .....	6-34
Torsional Damper .....	6-30	Timing Gears .....	6-35
Removal .....	6-30	Replacement .....	6-35
Installation .....	6-31	Flywheel .....	6-35
Crankcase Front Cover .....	6-32	Removal .....	6-35
Removal .....	6-32	Repair .....	6-36
Installation .....	6-32	Installation .....	6-36
Oil Seal (Front Cover) .....	6-33	Engine Mounts .....	6-36
Replacement .....	6-33	Checking Engine Mounts .....	6-36
Camshaft .....	6-33	Replacement (Front) .....	6-37
		Replacement (Rear) .....	6-37

## GENERAL DESCRIPTION

The In-Line engines covered in this section are the 250 and 292 cu. in. L6 engines used in 10-30 Series truck vehicles (fig. 1L).

This section covers the removal and installation of engine assemblies, the removal, installation and adjustment of some sub-assemblies and replacement of some components. For service to all components and sub-assemblies (after removal) and removal of some sub-assemblies, refer to Section 6 of the Chassis Overhaul Manual.

Because of the interchangeability and similarity of many engine sub-assemblies and parts, regardless of which truck vehicle they are used in, typical illustrations and procedures are used (except where specific illustrations or procedures are necessary to clarify the operation). Although illustrations showing bench operations are used, most single operations, when not part of a general overhaul, should be performed (if practical) with the engine in the vehicle.

## COMPONENT REPLACEMENT AND ADJUSTMENT

### Engine Assembly

#### Removal (C, K and P Series)

1. Disconnect battery cables and drain cooling system.
2. Remove the air cleaner.
3. Perform the following preliminary operations.
  - ON CS 10-20-30, KS 10-20 SERIES:
    - Remove the hood as outlined in Section 11.
    - Remove the radiator and shroud as outlined in Section 13.
  - ON PS 10-20-30 SERIES:
    - Remove the engine box and hood as outlined in Section 11.
    - Remove the battery.
    - Remove the radiator and shroud as outlined in Section 13.
4. Disconnect wires at:
  - Starter Solenoid.
  - Delcotron.
  - Temperature Switch.
  - Oil Pressure Switch.
  - Coil.
  - Vacuum Advance Solenoid (if so equipped).

#### 5. Disconnect:

- Accelerator linkage at manifold bellcrank.
- Fuel line (from tank) at fuel pump.
- Heater hoses at engine connection.
- Oil pressure gauge line (if so equipped).
- Vacuum lines at engine (as required).
- Evaporation Emission System lines at carburetor.
- Power steering pump at engine bracket and lay aside (if so equipped).
- Ground straps at engine.
- Exhaust pipe at manifold.

NOTE: Hang exhaust pipe at frame with wire.

#### 6. Remove fan and pulley as outlined in Section 6K.

#### 7. Remove clutch cross-shaft (if so equipped).

#### 8. Perform the following operations:

- Remove the rocker arm cover as outlined.
- Attach lifting device or chain to engine lifting brackets and take engine weight off mounts.

#### ON ALL SERIES EXCEPT CS 10-20-30:

- Support transmission and disconnect from engine. Refer to Section 7.

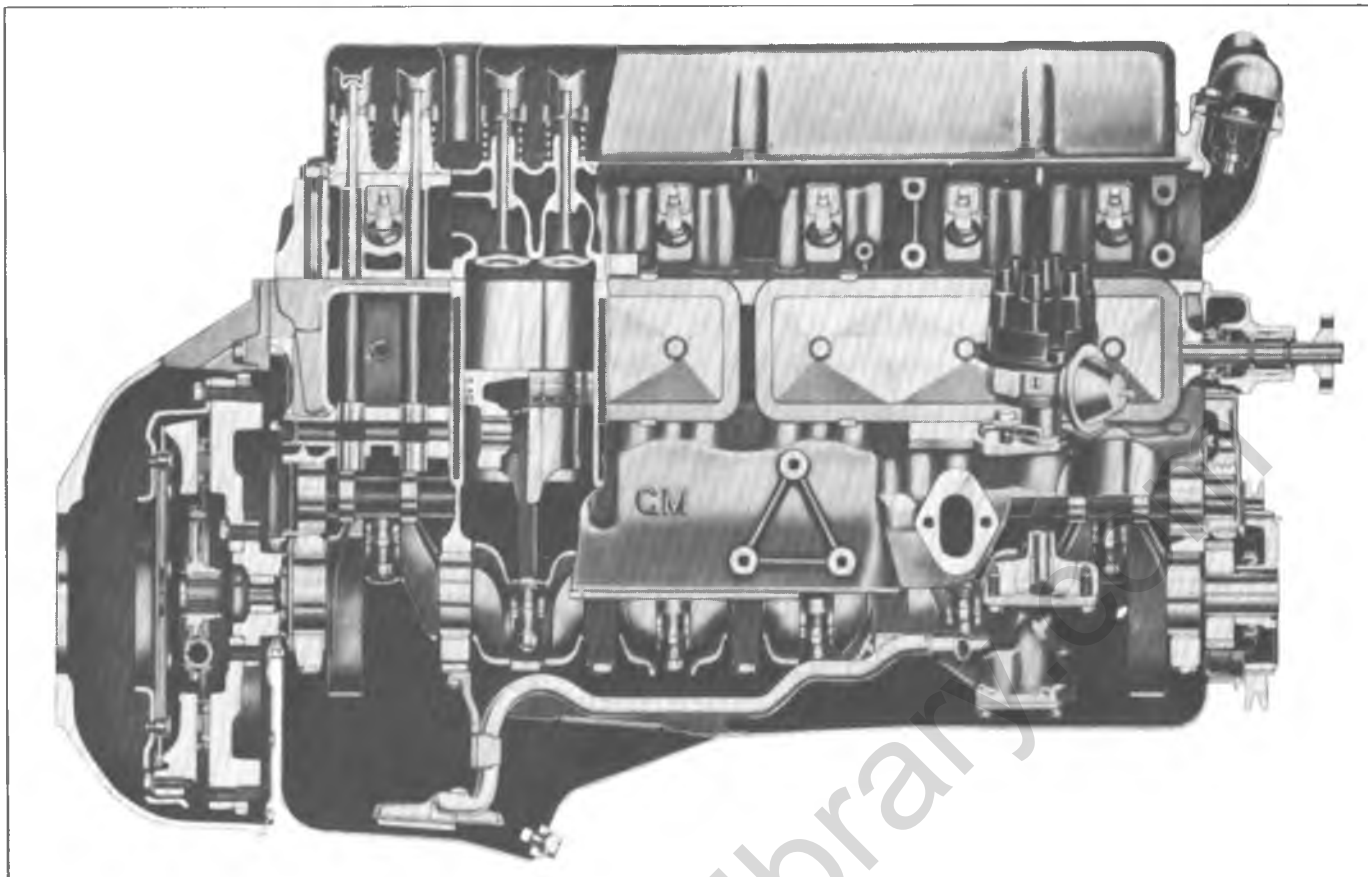

Fig. 1L—Six-Cylinder

- Remove engine mount bolts.

## ON CS 10-20-30:

- Remove propeller shaft as outlined in Section 4.

**NOTE:** If plug for propeller shaft opening in transmission is not available, drain transmission.

- Disconnect TCS switch at transmission.
- Disconnect speedometer cable at transmission.
- Disconnect shift linkage at transmission.
- Disconnect clutch linkage (as required).
- Remove engine mount bolts.
- Transmission cooler lines (if so equipped).

## 9. Remove engine from vehicle as follows:

**CAUTION:** Check often during engine removal to be sure all necessary disconnects have been made.

## ON CS 10-20-30 SERIES:

- On vehicles with automatic or four speed transmission, remove rear mount crossmember.
- Raise engine and transmission assembly and pull forward until removed.

## ON KS 10-20 SERIES:

- Raise engine and pull forward until disconnected from transmission.

- Continue to raise engine until removed from vehicle.

## ON PS 10-20-30 SERIES:

- Raise engine and push forward to clear cross-member and disconnect from transmission.
- Remove engine from vehicle.

## 10. If engine is to be mounted in an engine stand perform the following:

## ON CS 10-20-30:

- Remove synchromesh transmission and clutch (if so equipped).
  - a. Remove clutch housing rear cover bolts.
  - b. Remove bolts attaching the clutch housing to engine block then remove transmission and clutch housing as a unit.

**NOTE:** Support the transmission as the last mounting bolt is removed and as it is being pulled away from the engine, to prevent damage to clutch disc.

- c. Remove starter and clutch housing rear cover.
- d. Loosen clutch mounting bolts a turn at a time (to prevent distortion of clutch cover) until the



spring pressure is released. Remove all bolts, clutch disc and pressure plate assembly.

- Remove automatic transmission (if so equipped).
- a. Lower engine, secured by the hoist, and support engine on blocks.
- b. Remove starter and converter housing under pan.
- c. Remove flywheel-to-converter attaching bolts.
- d. Support transmission on blocks.
- e. Disconnect throttle linkage and vacuum modulator line.
- f. Remove transmission-to-engine mounting bolts.
- g. With the hoist attached, remove blocks from the engine only and slowly guide the engine from the transmission.

ON ALL SERIES EXCEPT CS 10-20-30:

- Remove clutch housing.
- Loosen clutch mounting bolts a turn at a time (to prevent distortion of clutch cover) until the spring pressure is released. Remove all bolts, clutch disc and pressure plate assembly.

11. Mount engine in engine stand and remove lifting device and lifting adapter.

#### Removal (G Series)

1. Remove vehicle grille as outlined in Section 13.
2. Drain cooling system and disconnect heater hoses at engine; disconnect radiator hoses at engine.
3. Disconnect automatic transmission cooler lines at radiator.
4. Remove fan guard and radiator - position headlamp wiring out of way.
5. Remove radiator upper tie bar and center support.
6. Disconnect battery cables at battery and at radiator support baffle.
7. Disconnect engine wiring harness at dash mounted fuse panel; at cowl attachments, and position loose harness assembly on engine.
8. Disconnect oil pressure gauge, if so equipped.
9. Raise vehicle on a hoist and disconnect:
  - Fuel line (from tank) at fuel pump.
  - Engine ground strap(s).
  - Battery cables at frame-mounted clip - lay cables across engine.
  - Speedometer cable at transmission.
  - Exhaust pipe at manifold and at pipe hangers - then remove exhaust system from vehicle.
  - Transmission at crossmember.
10. Disconnect clutch linkage and/or transmission

linkage and remove cross shaft as outlined in Section 7.

11. Remove propeller shaft as outlined in Section 4 - install plug in transmission extension.
  12. Remove engine mount through bolts.
  13. Remove crossmember-to-engine mount bracket (right side only) attaching bolts, but do not remove bracket at this time.
  14. Lower vehicle on hoist - leave vehicle on hoist and approximately 12 inches off the floor.
  15. Working from inside the vehicle - remove the engine access cover.
  16. Remove air cleaner assembly.
  17. Disconnect linkage from carburetor throttle lever, disconnect carburetor fuel inlet line and remove carburetor from manifold.
  18. Disconnect power brake vacuum line at inlet manifold.
  19. Disconnect spark plug wires from plugs and position wires out of the way.
  20. Remove the ignition coil and the engine rear lifting bracket.
  21. Position Tool J-24680-2 (fig. 2L) to the engine and install with provided bolts (fig. 3L).
  22. Attach lifting device to Tool J-24680-2 (fig. 4L).
  23. With the aid of an assistant, raise the engine slightly to remove weight from engine mounts; then remove the right mount frame bracket and mount.
  24. With assistant inside the vehicle, continue raising the engine while moving the engine assembly forward and out of vehicle (fig. 5L).
- CAUTION:** Check often when removing the engine to make sure that all disconnects have been made, and that engine does not interfere with surrounding components as it is being withdrawn from vehicle.
25. Remove synchromesh transmission and clutch (if so equipped).

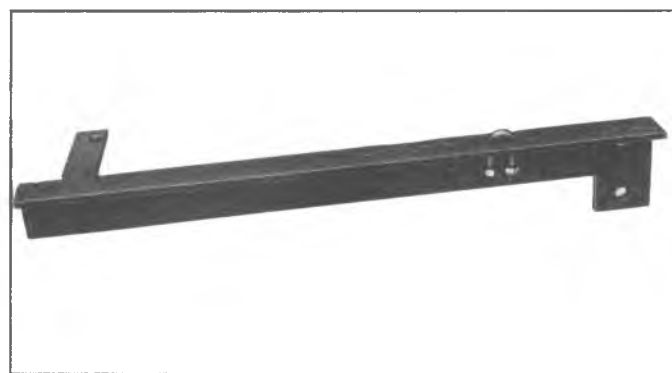

Fig. 2L—Engine Lifting Tool J-24680-2



Fig. 3L—Tool J-24680-2 Installed on Engine

- a. Remove clutch housing rear cover bolts.
- b. Remove bolts attaching the clutch housing to engine block, then remove transmission and clutch housing as a unit.

NOTE: Support the transmission as the last mounting bolt is removed and as it is being pulled away from the engine, to prevent damage to clutch disc.

- c. Remove starter and clutch housing rear cover.
  - d. Loosen clutch mounting bolts a turn at a time (to prevent distortion of clutch cover) until the spring pressure is released. Remove all bolts, clutch disc and pressure plate assembly.
26. Remove automatic transmission (if so equipped).
- a. Lower engine, secured by the hoist, and support engine on blocks.
  - b. Remove starter and converter housing underpan.
  - c. Remove flywheel-to-converter attaching bolts.
  - d. Support transmission on blocks.
  - e. Disconnect detent cable on Turbo Hydra-Matic.
  - f. Remove transmission-to-engine mounting bolts.
  - g. With the hoist attached, remove blocks from the engine only and slowly guide the engine away from the transmission.
27. Mount engine in engine stand and remove lifting device and lifting adapter.

#### Installation (C, K and P Series)

1. If engine was mounted in an engine stand, attach lifting adapter to engine lift brackets then using lifting device, remove engine from stand and perform the following:

ON CS 10-20-30:

- Install synchromesh transmission and clutch (if so equipped).



Fig. 4L—Lifting Device Installed to J-24680-2



Fig. 5L—Removing Engine Assembly

- a. Install the clutch assembly on flywheel as outlined in Section 7.
  - b. Install clutch housing rear cover and starter.
  - c. Install the transmission and clutch housing as outlined in Section 7.
  - d. Install clutch housing rear cover bolts and torque to specifications.
    - Install automatic transmission (if so equipped).
- a. Position engine adjacent to the transmission and align the converter with the flywheel.
  - b. Bolt transmission to engine then raise engine and transmission assembly and install flywheel to converter bolts.
  - c. Install converter housing underpan and starter.
  - d. Connect throttle linkage.

ON ALL SERIES EXCEPT CS 10-20-30:

- Install clutch assembly and clutch housing as outlined in Section 7.

## 2. Install engine in vehicle as follows:

**ON ALL SERIES EXCEPT CS 10-20-30:**

- Install engine, and lower until transmission shaft lines up with clutch.
- Push engine rearward and rotate crankshaft until transmission shaft and clutch engage.
- Install the engine mount bolts and torque to specifications.
- Connect transmission to engine.

**ON CS 10-20-30 SERIES:**

- Lower engine and transmission assembly and push rearward until engine mounts line up.
- On vehicles with automatic or four speed transmissions, install rear mount crossmember.
- Install the engine mount bolts and torque to specifications.
- Install the propeller shaft as outlined in Section 4.

**ON ALL SERIES:**

- Remove the lifting device and lifting adapter from engine lift brackets.
3. Connect transmission linkage (as required).
  4. Install clutch cross-shaft (as required).
  5. Install fan and pulley as outlined in Section 6K.
  6. Connect:
    - Transmission cooler lines (if so equipped).
    - Exhaust pipe at manifold.
    - Power steering pump (as required).
    - Vacuum lines at engine (as required).
    - Oil pressure gauge line (as required).
    - Heater hoses at engine connection.
    - Fuel line at fuel pump.
    - Accelerator linkage at manifold bellcrank.
    - TCS switch at transmission.
    - Evaporation Emission System hoses at canister.
  7. Connect wires at:
    - Coil
    - Oil Pressure Switch
    - Temperature Switch
    - Delcotron
    - Starter Solenoid
    - Vacuum Advance Solenoid
  8. Complete installation as follows:
    - **ON PS 10-20-30 SERIES:**
      - Install the radiator and shroud as outlined in Section 13.

- Install the battery.
- Install the floor panel and engine box as outlined in Section 1B.

**ON CS 10-20-30, KS 10-20 SERIES:**

- Install the radiator and shroud as outlined in Section 13.
  - Install the hood as outlined in Section 11.
9. Install the air cleaner, connect battery cables, fill cooling system and crankcase then start engine and check for leaks.

**Installation (G Series)**

1. If engine was mounted in an engine stand, attach Tool J-24680-2 to engine (fig. 2L), then using lifting device, remove engine from stand and perform the following:
  - Install synchromesh transmission and clutch (if so equipped).
    - a. Install the clutch assembly on flywheel as outlined in Section 7.
    - b. Install clutch housing rear cover and starter.
    - c. Install the transmission and clutch housing as outlined in Section 7.
    - d. Install clutch housing bolts and torque to specifications.
  - Install automatic transmission (if so equipped).
    - a. Position engine adjacent to the transmission and align the converter with the flywheel.
    - b. Bolt transmission to engine and then raise engine and transmission assembly and install flywheel to converter bolts.
    - c. Install converter housing underpan and starter.
    - d. Connect throttle linkage and detent cable on Turbo Hydra-Matic.
2. Raise engine assembly and with the aid of an assistant guide the engine assembly into position within the vehicle.
3. Install right crossmember-to-engine mount bracket, loosely install attaching bolts. Lower engine onto mount bracket and install engine mount through bolts.
4. Remove lifting device from Tool J-24680-2.
5. Raise vehicle on hoist and connect:
  - Transmission at crossmember.
  - Install exhaust system at pipe hangers and at manifold.
  - Speedometer cable at transmission.
  - Engine ground strap(s).
  - Fuel line (from tank) at fuel pump.
  - Battery cables at frame-mounted clip.

## 6-26 ENGINE

- Torque engine mount through bolts and crossmember frame bracket.
- Connect clutch linkage and/or transmission linkage and cross shaft as outlined in Section 7.
- Remove plug from transmission extension and install propeller shaft as outlined in Section 4.
- Lower vehicle on a hoist.
- Connect oil pressure gauge, if so equipped.
- Connect engine wiring harness at cowl attachments and at dash mounted fuse panel.
- Install radiator upper tie bar and center support.
- Install radiator then position headlamp wiring along upper tie bar and install fan guard.
- Connect automatic transmission cooler lines at radiator.
- Connect heater hoses at engine; connect radiator hoses at engine and connect coolant recovery hose to radiator overflow tube.
- Install vehicle grille as outlined in Section 13.
- Working from inside the vehicle, install power brake vacuum line at inlet manifold.
- Remove Tool J-24680-2 from engine and install ignition coil and air cleaner support and rear lift bracket.
- Install spark plug wires.
- Install carburetor to manifold and connect Idle Stop Solenoid electrical lead, throttle linkage and fuel inlet line.
- Install air cleaner assembly.
- Connect battery cables to battery and to radiator baffle.
- Check engine oil level (add oil if required) fill coolant system, start engine and check and adjust to ensure proper operation.
- Install the engine access cover.

### Manifold Assembly

#### Removal

- Remove air cleaner.
- Disconnect both throttle rods at bellcrank and remove throttle return spring.
- Disconnect fuel and vacuum lines and choke cable at carburetor.
- Disconnect crankcase ventilation hose at rocker arm cover.
- Disconnect exhaust pipe at manifold flange and discard packing.
- Remove manifold attaching bolts and clamps then remove manifold assembly and discard gaskets.
- Check for cracks in manifold castings.

- Separate manifolds by removing one bolt and two nuts at center of assembly.
- Disconnect exhaust gas recirculation valve hose.

#### Installation

- Clean gasket surfaces on cylinder head and manifolds.
- Lay a straight edge along the full length of the exhaust port faces and measure any gaps between the straight edge and the port faces. If at any point a gap of .015 or more exists, it is likely the manifold has distorted to a point where it will not seat properly. If a good exhaust seal is to be expected, the exhaust manifold must be replaced.
- Reinstall the one bolt and two nuts at the center of the manifold to finger tight.
- Position new gasket over manifold end studs on the cylinder head.
- Install manifold assembly bolts and clamps while holding manifold assembly in place by hand.
- Clean, oil and torque all manifold assembly-to-cylinder head bolts and nuts to specifications.
- Complete torqueing the inlet to exhaust manifold bolt and two nuts at the center of the manifold to specifications.
- Connect exhaust pipe to manifold using a new packing.
- Connect crankcase ventilation hose at rocker arm cover.
- Connect exhaust gas recirculation valve hose.
- Connect fuel and vacuum lines at carburetor.
- Connect throttle rods at bellcrank and install throttle return spring.
- Install air cleaner, start engine, check for leaks and adjust carburetor idle speed.

### Rocker Arm Cover

#### Removal

- Disconnect crankcase ventilation hose(s) at rocker arm cover.
- Remove air cleaner.
- Disconnect temperature wire from rocker arm cover clips.
- Remove air injection hose at check valve of AIR pipe (if so equipped).
- Remove rocker arm cover.

#### Installation

- Clean gasket surfaces on cylinder head and rocker gasket, install rocker arm cover and torque to specifications.
- Connect temperature wire at rocker arm cover clips.
- Install air cleaner.

4. Connect crankcase ventilation hoses.
5. Install air injection hose.

## Valve Mechanism

### Removal

1. Remove rocker arm cover as outlined.
2. Remove rocker arm nuts, rocker arm balls, rocker arms and push rods.

**NOTE:** Place rocker arms, rocker arm balls and push rods in a rack so that they may be reinstalled in the same location.

### Installation and Adjustment

**NOTE:** Whenever new rocker arms and/or rocker arm balls are being installed, coat bearing surfaces of rocker arms and rocker arm balls with "Molykote" or its equivalent.

1. Install push rods. Be sure push rods seat in lifter socket.
2. Install rocker arms, rocker arm balls and rocker arm nuts. Tighten rocker arm nuts until all lash is eliminated.
3. Adjust valves when lifter is on base circle of camshaft lobe as follows:
  - a. Mark distributor housing, with chalk, at number one and number six cylinder positions (plug wire) then disconnect plug wires at spark plugs and coil and remove distributor cap and plug wire assembly (if not previously done).
  - b. Crank engine until distributor rotor points to number one cylinder position and breaker points are open. The following valves can be adjusted with engine in number one firing position.

Number one cylinder-Exhaust and Intake

Number two cylinder-Intake

Number three cylinder-Exhaust

Number four cylinder-Intake

Number five cylinder-Exhaust

- c. Back out adjusting nut until lash is felt at the push rod then turn in adjusting nut until all lash is removed. This can be determined by checking push rod side play while turning adjusting nut (fig. 6L). When play has been removed, turn adjusting nut in one full additional turn (to center lifter plunger).
- d. Crank engine until distributor rotor points to number six position and breaker points are open. The following valves can be adjusted with engine in number six firing position:

Number two cylinder-Exhaust

Number three cylinder-Intake

Number four cylinder-Exhaust

Number five cylinder-Intake

Number six cylinder-Intake and Exhaust

4. Install distributor cap and spark plug wire assembly.
5. Install rocker arm cover as outlined.
6. Adjust carburetor idle speed.

## Valve Lifters

Hydraulic valve lifters very seldom require attention. The lifters are extremely simple in design. Readjustments are not necessary, and servicing of the lifters requires only that care and cleanliness be exercised in the handling of parts.

### Locating Noisy Lifters

Locate a noisy valve lifter by using a piece of garden hose approximately four feet in length. Place one end of the hose near the end of each intake and exhaust valve with the other end of the hose to the ear. In this manner, the sound is localized making it easy to determine which lifter is at fault.

Another method is to place a finger on the face of the valve spring retainer. If the lifter is not functioning properly, a distinct shock will be felt when the valve returns to its seat.

The general types of valve lifter noise are as follows:

1. Hard Rapping Noise — Usually caused by the plunger becoming tight in the bore of the lifter body to such an extent that the return spring can no longer push the plunger back up to working position. Probable causes are:



Fig. 6L—Valve Adjustment

## 6-28 ENGINE

- a. Excessive varnish or carbon deposit causing abnormal stickiness.
  - b. Galling or "pickup" between plunger and bore of lifter body, usually caused by an abrasive piece of dirt or metal wedging between plunger and lifter body.
2. Moderate Rapping Noise — Probable causes are:
    - a. Excessively high leakdown rate.
    - b. Leaky check valve seat.
    - c. Improper adjustment.
  3. General Noise Throughout the Valve Train — This will, in most cases, be caused by either insufficient oil supply or improper adjustment.
  4. Intermittent Clicking — Probable causes are:
    - a. A microscopic piece of dirt momentarily caught between ball seat and check valve ball.
    - b. In rare cases, the ball itself may be out-of-round or have a flat spot.
    - c. Improper adjustment.

In most cases, where noise exists in one or more lifters, all lifter units should be removed, disassembled, cleaned in a solvent, reassembled, and reinstalled in the engine. If dirt, varnish, carbon, etc. is shown to exist in one unit, it more than likely exists in all the units, thus it would only be a matter of time before all lifters caused trouble.

### Removal

1. Remove valve mechanism as outlined.
2. Mark distributor housing, with chalk, at number one and number six cylinder position (plug wire) then disconnect plug wires at spark plugs and coil and remove distributor cap and plug wire assembly.
3. Crank engine until distributor rotor points to number one position, then disconnect distributor primary lead at coil and remove distributor.
4. Remove push rod covers (discard gaskets).
5. Remove valve lifters.

NOTE: Place valve lifters in a rack so that they may be reinstalled in the same location.

### Installation

1. Install valve lifters.

NOTE: Whenever new valve lifters are being installed, coat foot of valve lifters with "Molykote" or its equivalent.
2. Install push rod covers, using new gaskets, and torque to specifications.
3. Install distributor, positioning rotor to number one cylinder position, then connect primary lead at coil.
4. Install and adjust valve mechanism as outlined.
5. Adjust ignition timing and carburetor idle speed.

## Valve Stem Oil Seal and/or Valve Spring

### Replacement

1. Remove rocker arm cover as outlined.
2. Remove spark plug, rocker arm and push rod on the cylinder(s) to be serviced.
3. Install air line adapter Tool J-23590 to spark plug port and apply compressed air to hold the valves in place.
4. Using Tool J-5892 to compress the valve spring, remove the valve locks, valve cap, valve shield and valve spring and damper (fig. 3L).
5. Remove the valve stem oil seal.
6. To replace, set the valve spring and damper, valve shield and valve cap in place. Compress the spring with Tool J-5892 and install oil seal in the lower groove of the stem, making sure the seal is flat and not twisted.

NOTE: A light coat of oil on the seal will help prevent twisting.

7. Install the valve locks and release the compressor tool, making sure the locks seat properly in the upper groove of the valve stem.

NOTE: Grease may be used to hold the locks in place while releasing the compressor tool.

8. Install spark plug and torque to specifications.
9. Install and adjust valve mechanism as outlined.

## Cylinder Head Assemblies

### Removal

1. Remove manifold assembly as outlined.
2. Remove valve mechanism as outlined.
3. Drain cooling system (block).

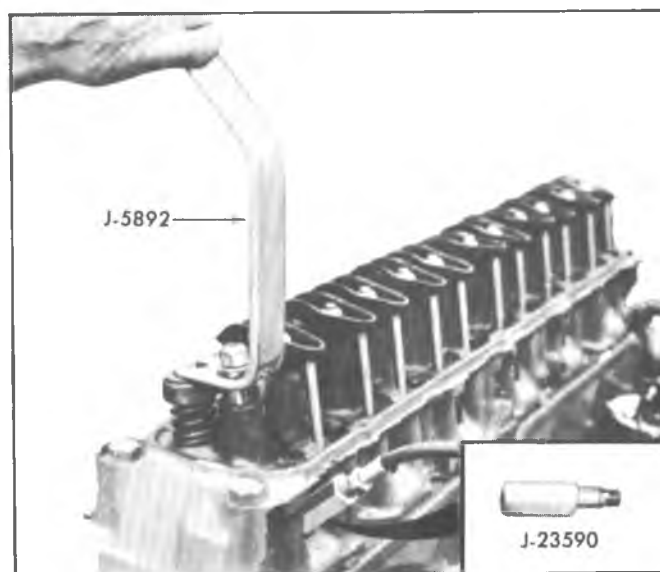

Fig. 7L—Compressing Valve Spring

4. Remove fuel and vacuum line from retaining clip at water outlet then disconnect wires from temperature sending units.
5. Disconnect air injection hose at check valve.
6. Disconnect radiator upper hose at water outlet housing and battery ground strap at cylinder head.
7. Remove coil.
8. Remove cylinder head bolts, cylinder head and gasket. Place cylinder head on two blocks of wood to prevent damage.

### Installation

**CAUTION:** *The gasket surfaces on both the head and the block must be clean of any foreign matter and free of nicks or heavy scratches. Cylinder bolt threads in the block and threads on the cylinder head bolt must be cleaned. (Dirt will affect bolt torque). Do not use gasket sealer on composition steel asbestos gaskets.*

1. Place the gasket in position over the dowel pins with the bead up.
2. Carefully guide cylinder head into place over dowel pins and gasket.
3. Coat threads of cylinder head bolts with sealing compound and install finger tight.
4. Tighten cylinder head bolts a little at a time in the sequence shown on the torque sequence chart until the specified torque is reached.
5. Connect air injection hose at check valve.
6. Install coil.
7. Connect radiator upper hose and engine ground strap.
8. Connect temperature sending unit wires and install fuel and vacuum lines in clip at water outlet.
9. Fill cooling system.
10. Install manifold assembly as outlined.
11. Install and adjust valve mechanism as outlined.
12. Install and torque rocker arm cover.

### Oil Pan

#### Removal

1. Disconnect battery ground cable.
2. Raise vehicle on a hoist and disconnect starter at engine block - leave electrical connections intact and position starter out of way.
3. Remove bolts securing engine mounts to crossmember brackets - then, using a suitable jack with a flat piece of wood to protect oil pan, raise engine sufficiently to insert 2" x 4" wood block between engine mounts and crossmember brackets (fig. 8L).
4. Drain engine oil and remove flywheel (convertor) cover.



Fig. 8L—Engine Blocked for Oil Pan Removal

5. Remove engine mount spacer on C Series vehicles.
6. Remove oil pan bolts and withdraw oil pan from engine.

#### Installation

1. Discard old gaskets and seals, thoroughly clean all gasket sealing surfaces.
  2. Install new rear seal in rear main bearing cap.
  3. Install new front seal on crankcase front cover, pressing tips into holes provided in cover.
  4. Install new side gaskets on cylinder block (fig. 9L).
- NOTE: DO NOT USE SEALER.**
5. Position oil pan to block, making sure that seals and gaskets remain in place, install and torque pan screws to specifications.
  6. Raise engine as outlined above and remove blocks used to support engine.
  7. Lower engine, install and torque mount-to-crossmember bracket bolts.
  8. Install starter and flywheel (convertor) cover.
  9. Install engine mount spacer on C Series vehicles.
  10. Fill engine with specified quantity of oil, then start engine and check for leaks.

### Oil Pump

#### Removal

1. Remove oil pan as outlined.
2. Remove two flange mounting bolts, pickup pipe bolt, then remove pump and screen as an assembly.

#### Installation

1. Align oil pump drive shafts to match with distributor tang, then install oil pump to block

## 6-30 ENGINE

positioning flange over distributor lower bushing. Use no gasket.

**NOTE:** Oil pump should slide easily into place, if not, remove and reposition slot to align with distributor tang.

2. Install oil pan as outlined.

### Oil Seal (Rear Main)

#### Replacement

**NOTE:** Always replace the upper and lower seal as a unit. Install seal with lip facing front of engine.

The rear main bearing oil seal can be replaced (both halves) without removal of the crankshaft. Extreme care should be exercised when installing this seal to protect the sealing bead located in the channel on the outside diameter of the seal. An installation tool (fig. 10L) can be used to protect the seal bead when positioning seal as follows:

1. With the oil pan and oil pump removed, remove the rear main bearing cap.
2. Remove oil seal from the bearing cap by prying from the bottom with a small screw driver (fig. 11L).
3. To remove the upper half of the seal, use a small hammer to tap a brass pin punch on one end of seal until it protrudes far enough to be removed

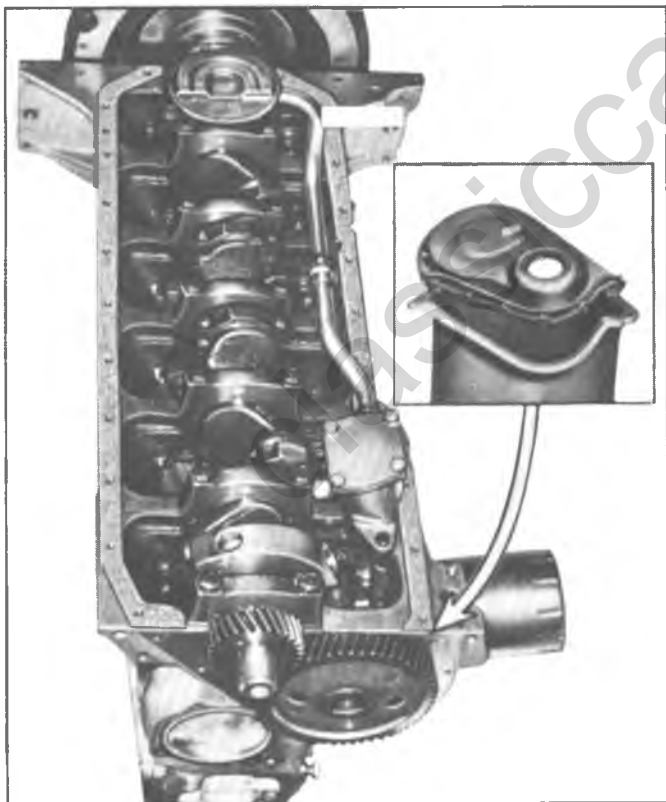

Fig. 9L—Oil Pan Gasket and Seal Location

4. Clean all sealant and foreign material from cylinder case bearing cap and crankshaft, using a non-abrasive cleaner.
5. Inspect components for nicks, scratches, burrs and machining defects at all sealing surfaces, case assembly and crankshaft.
6. Coat seal lips and seal bead with light engine oil — keep oil off seal mating ends.
7. Position tip of tool between crankshaft and seal seat in cylinder case.
8. Position seal between crankshaft and tip of tool so that seal bead contacts tip of tool.

**NOTE:** Make sure that oil-seal lip is positioned toward front of engine (fig. 13L).

9. Roll seal around crankshaft using tool as a “shoe-horn” to protect seal bead from sharp corner of seal seat surface in cylinder case.

**CAUTION:** Installation tool must remain in position until seal is properly positioned with both ends flush with block.

10. Remove tool, being careful not to withdraw seal.
11. Install seal half in bearing cap, again using tool as a “shoe-horn”, feeding seal into cap using light pressure with thumb and finger.
12. Install bearing cap to case with sealant applied to the cap-to-case interface, being careful to keep sealant off the seal split line (fig. 14L).
13. Install the rear main bearing cap (with new seal) and torque to specifications.

### Torsional Damper

#### Removal

1. Drain radiator and disconnect radiator hoses at radiator.
2. Remove radiator core, as outlined in Section 13.
3. Remove fan belt and (if so equipped) accessory drive pulley and belt. If so equipped, remove retaining bolt.
4. Install Tool J-23523 to damper and turn puller

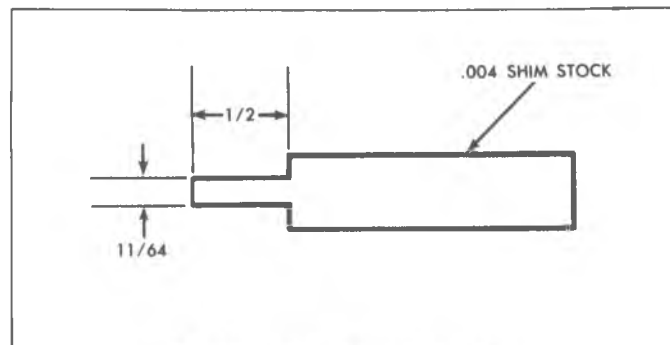

Fig. 10L—Oil Seal Installation Tool





Fig. 11L—Removing Oil Seal (Lower Half) Typical

screw to remove damper (fig. 15L). Remove tool from damper.

### Installation

**CAUTION:** The inertia weight section of the torsional damper is assembled to the hub with a rubber type material. The installation procedures (with proper tool) must be followed or movement of the inertial weight section on the hub will destroy the tuning of the torsional damper.

1. Coat front seal contact area (on damper) with engine oil.
2. Install torsional damper as follows:

#### DRIVE ON TYPE (Without retaining bolt)

- a. Attach damper installer Tool J-22197 to damper. Tighten fingers of tool to prevent inertia weight from moving (fig. 16L).

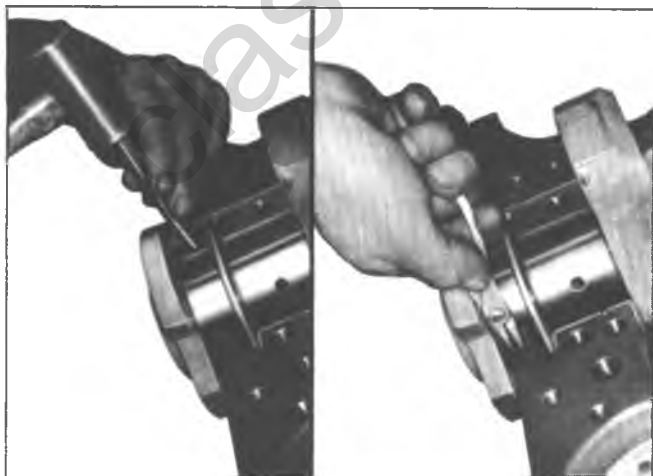

Fig. 12L—Removing Oil Seal (Upper Half) Typical

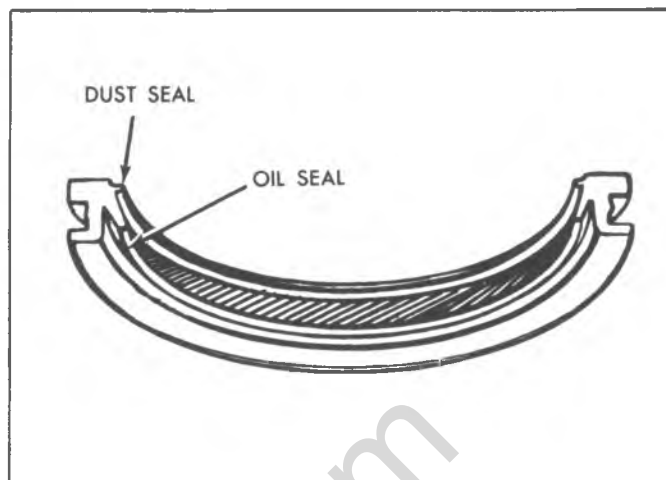

Fig. 13L—Crankshaft Oil Seal (Rear Main)

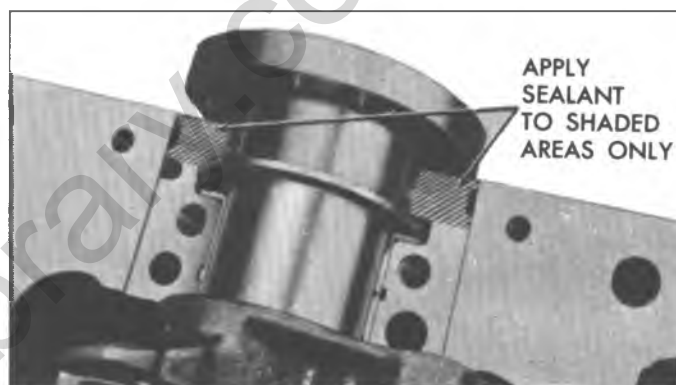

Fig. 14L—Sealing Bearing Cap

- b. Position damper on crankshaft and drive into position, using J-5590, until it bottoms against crankshaft gear (fig. 16L). Remove installer tool.

#### PULL ON TYPE (With retaining bolt)

- a. Install 7/16 threaded end of Tool J-23523 into crankshaft.

**CAUTION:** Install tool in crankshaft so that at least 1/2" of thread engagement is obtained.

- b. Position damper on crankshaft, aligning damper with key on crankshaft.
- c. Install plate, thrust bearing and nut to complete tool installation.
- d. Pull damper into position as shown in Figure 17L.
- e. Remove tool from crankshaft.
3. Install fan belt and adjust, using strand tension gauge.
4. If so equipped, install accessory drive pulley and belt.
5. Install radiator core as outlined in Section 13.
6. Connect radiator hoses.
7. Fill cooling system and check for leaks.

## Crankcase Front Cover

### Removal

1. Remove torsional damper as outlined.
2. Remove the two, oil pan-to-front cover attaching screws.
3. Remove the front cover-to-block attaching screws.
4. Pull the cover slightly forward only enough to permit cutting of oil pan front seal.
5. Using a sharp knife or other suitable cutting tool, cut oil pan front seal flush with cylinder block at both sides of cover (fig. 18L).
6. Remove front cover and attached portion of oil pan front seal. Remove front cover gasket.

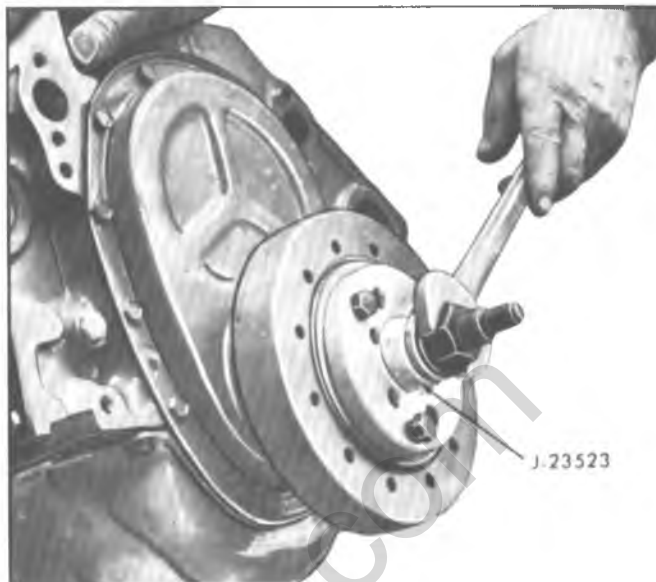

Fig. 17L—Installing Torsional Damper (Pull on Type)

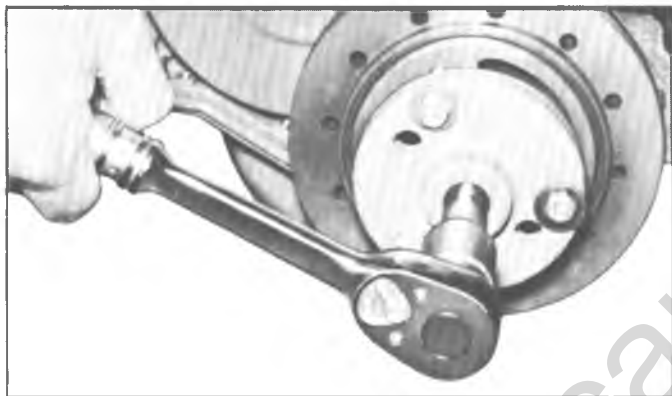

Fig. 15L—Removing Torsional Damper

### Installation

1. Clean gasket surfaces on block and crankcase front cover.
2. Cut tabs from the new oil pan front seal (fig. 19L) use a sharp instrument to ensure a clean cut.
3. Install seal to front cover, pressing tips into holes provided in cover.
4. Coat the gasket with gasket sealer and place in position on cover.

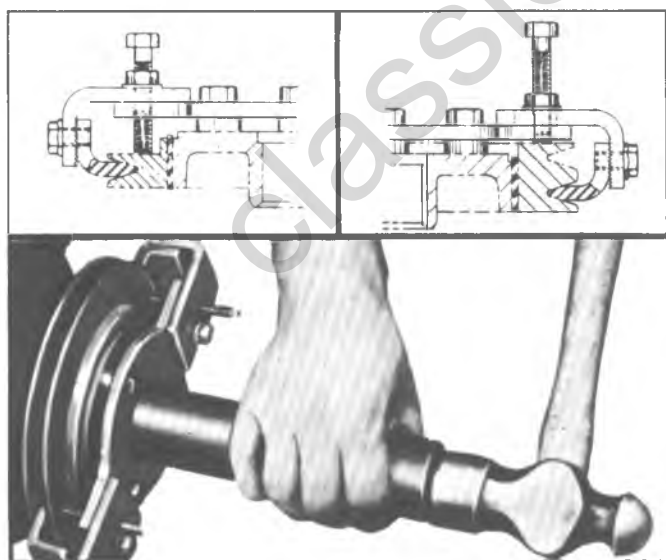

Fig. 16L—Installing Torsional Damper (Drive on Type)



Fig. 18L—Cutting Tabs on Oil Pan Front Seal

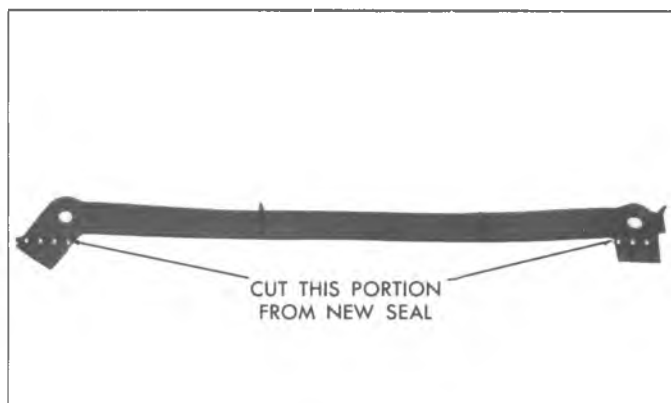

Fig. 19L—Oil Pan Front Seal Modification

5. Apply a 1/8 inch bead of silicone rubber sealer part #1051435 (or equivalent) to the joint formed at the oil pan and cylinder block (fig. 20L).
6. Install centering tool J-23042 in crankcase front cover seal.
 

NOTE: It is important that centering tool be used to align crankcase front cover so that torsional damper installation will not damage seal and so that seal is positioned evenly around balancer.
7. Install crankcase front cover to block. Install and partially tighten the two, oil pan-to-front cover screws.
8. Install the front cover-to-block attaching screws.
9. Remove centering Tool J-23042 and torque all cover attaching screws to specifications.
10. Install torsional damper as outlined.

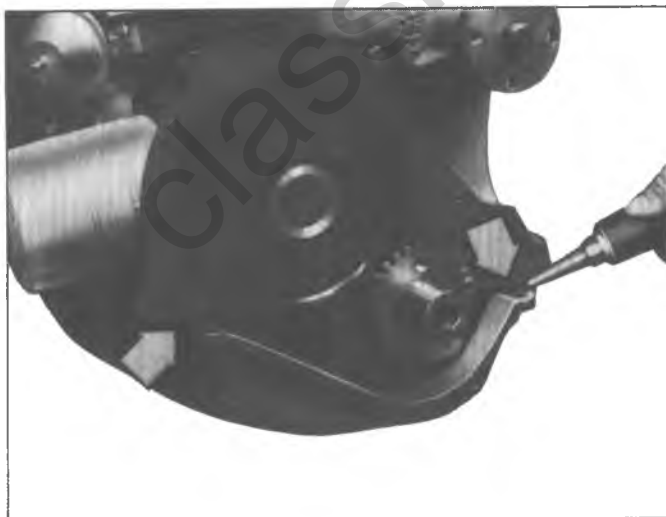

Fig. 20L—Applying Front Cover Sealer

## Oil Seal (Front Cover)

### Replacement

#### With Cover Removed

1. With cover removed, pry seal out of cover from the front with a large screw driver being careful not to distort cover.
2. Install new seal so that open end of the seal is toward the inside of cover, and drive it into position with Tool J-23042 (fig. 22L).

**CAUTION:** Support cover at sealing area. (Tool J-971 may be used as support).

#### Without Cover Removed

1. With crankshaft pulley and hub or damper removed, pry old seal out of cover from the front with a large screw driver, being careful not to damage the seal surface on the crankshaft.
2. Install new seal so that open end of seal is toward the inside of cover and drive it into position with Tool J-23042 (fig. 23L).

## Camshaft

### Measuring Lobe Lift

NOTE: Procedure is similar to that used for checking valve timing. If improper valve operation is indicated, measure the lift of each push rod in consecutive order and record the readings.

1. Remove valve mechanism as outlined.
2. Position indicator with ball socket adapter (Tool J-8520) on push rod (fig. 24L).
3. Rotate the crankshaft slowly in the direction of rotation until the lifter is on the heel of the cam

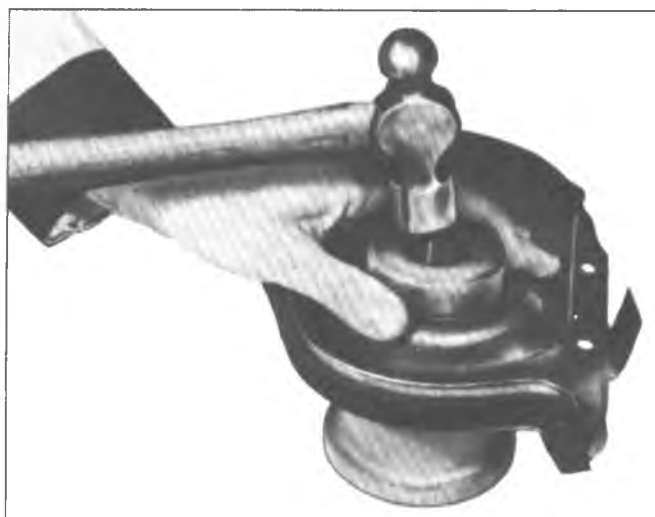

Fig. 22L—Installing Oil Seal (Cover Removed)

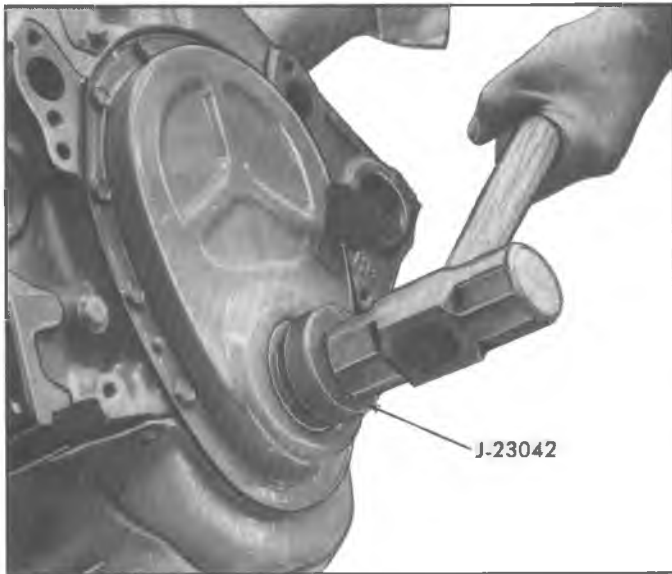

Fig. 23L—Installing Oil Seal (Cover Installed)  
(Typical)

lobe. At this point, the push rod will be in its lowest position.

- Set dial indicator on zero, then rotate the crankshaft slowly, or attach an auxiliary starter switch and “bump” the engine over, until the push rod is in the fully raised position.

**CAUTION:** Whenever the engine is cranked remotely at the starter, with a special jumper cable or other means, the distributor primary lead must be disconnected from the negative post on the coil.

- Compare the total lift recorded from the dial indicator with specifications.
- Continue to rotate the crankshaft until the indicator reads zero. This will be a check on the accuracy of the original indicator reading.
- If camshaft readings for all lobes are within specifications, remove dial indicator assembly.
- Install and adjust valve mechanism as outlined.

#### Removal

- Remove valve lifters as outlined.
- Remove crankcase front cover as outlined.
- Remove grille as outlined in Section 13.
- Remove fuel pump as outlined in Section 6M.
- Align timing gear marks then remove the two camshaft thrust plates screws by working through holes in the camshaft gear (fig. 25L).
- Remove the camshaft and gear assembly by pulling it out through the front of the block.

NOTE: Support camshaft carefully when

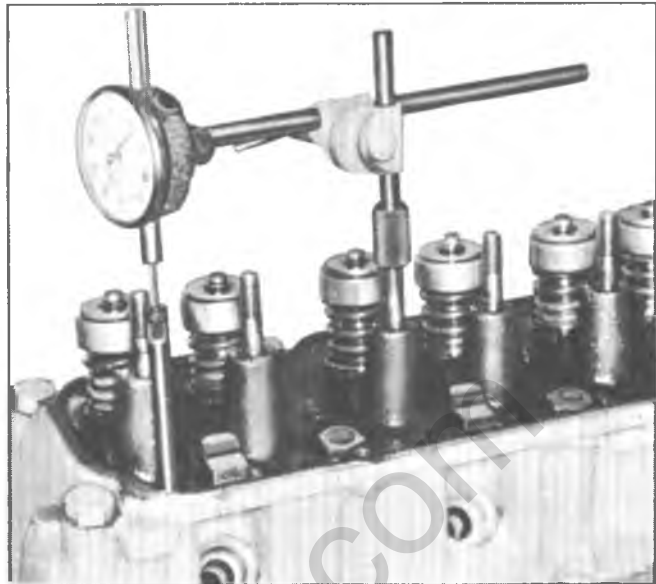

Fig. 24L—Measuring Camshaft Lobe Lift

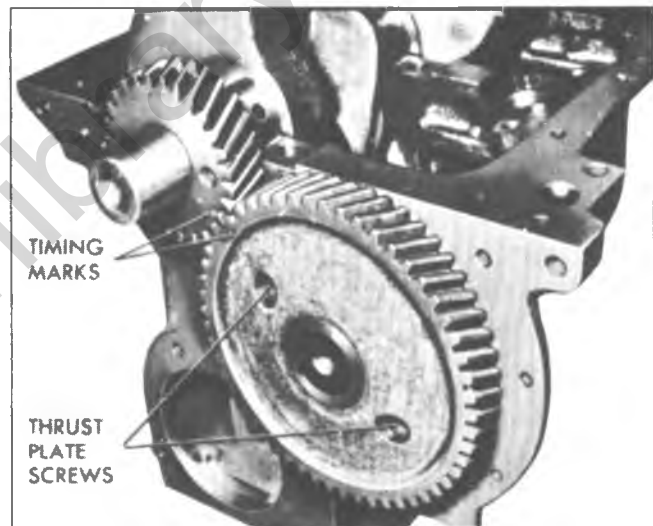

Fig. 25L—Timing Gear Alignment Marks

removing so as not to damage camshaft bearings.

#### Installation

- Install the camshaft and gear assembly in the engine block, being careful not to damage camshaft bearings or camshaft.
- Turn crankshaft and camshaft so that the valve timing marks on the gear teeth will line up (fig. 25L). Push camshaft into position. Install camshaft thrust plate to block screws and torque to specifications.
- Check camshaft and crankshaft gear runout with a dial indicator (fig. 26L). The camshaft gear run out should not exceed .004" and the crankshaft gear run out should not exceed .003".

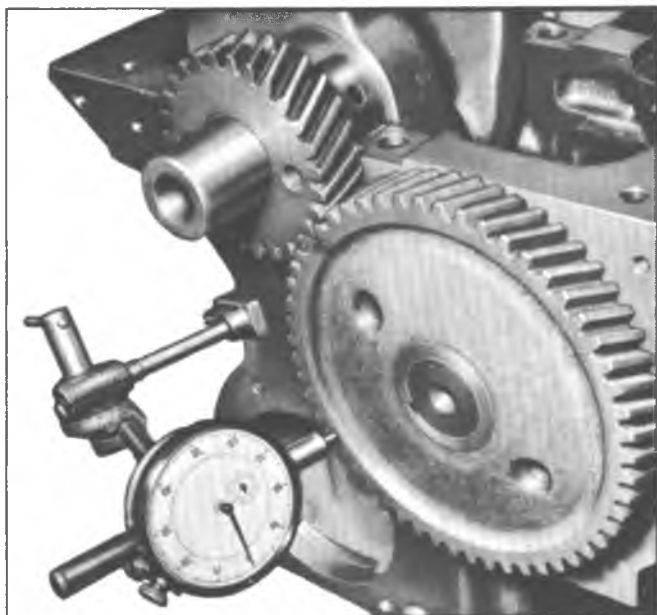

Fig. 26L—Checking Camshaft Gear Runout

4. If gear run out is excessive, the gear will have to be removed and any burrs cleaned from the shaft or the gear will have to be replaced.
5. Check the backlash between the timing gear teeth with a dial indicator (fig. 27L). The backlash should be not less than .004" nor more than .006".
6. Install fuel pump as outlined in Section 6M.
7. Install grille as outlined in Section 13.
8. Install crankcase front cover as outlined.
9. Install valve lifters as outlined.

## Timing Gears

### Replacement

With camshaft removed, crankshaft gear may be removed using Tool J-8105 (fig. 28L). To install crankshaft gear use Tool J-5590 (fig. 29L). For camshaft gear replacement, refer to "Camshaft Disassembly" in the Chassis Overhaul Manual.

## Flywheel

### Removal

**(All Except 292 cu. in. Engines)**

1. Remove transmission and/or clutch housing and clutch from engine.
2. Remove flywheel retaining bolts and remove flywheel.

**(292 cu. in. Engines)**

1. Remove transmission and/or clutch housing and clutch from engine.
2. Mark relationship of flywheel and crankshaft so

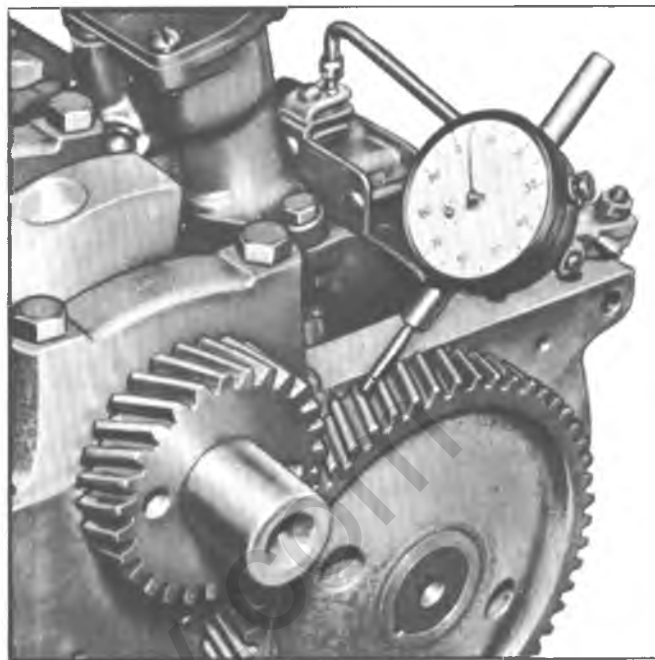

Fig. 27L—Checking Timing Gear Backlash

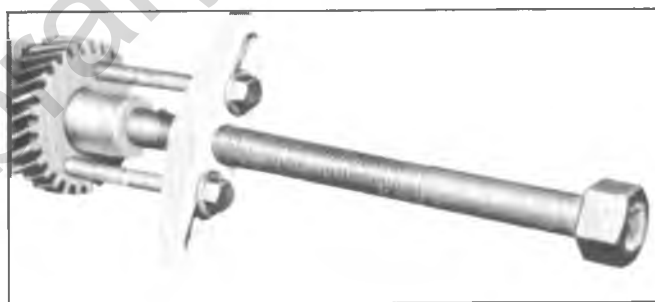

Fig. 28L—Removing Crankshaft Gear

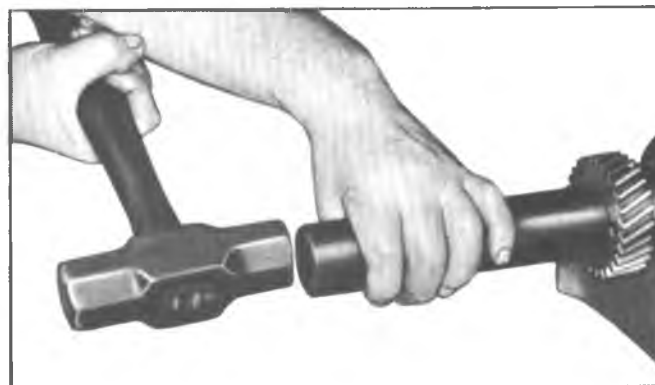

Fig. 29L—Installing Crankshaft Gear

that dowel holes can be aligned in their original positions on assembly.

3. Remove engine oil pan and rear main bearing cap.
4. Remove flywheel retaining bolts and drive crankshaft dowels out of flywheel and crankshaft. Rotate

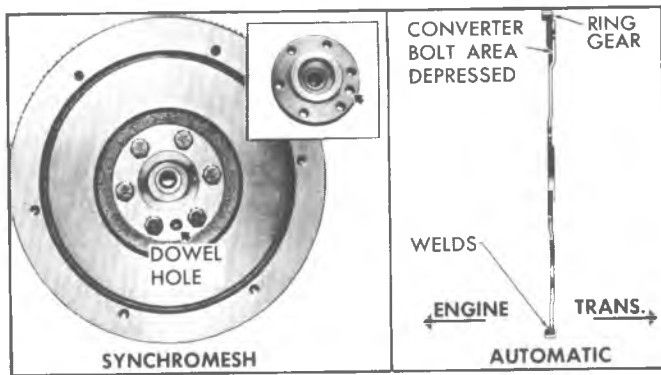

Fig. 30L—Flywheel Installation (Typical)

crankshaft as necessary so dowels clear cylinder block.

5. Remove flywheel and discard used dowel pins.

### Repair

Only repair recommended at flywheel used with conventional clutch is replacement of starter gear in event gear is worn or otherwise damaged.

Use torch to heat the gear around entire circumference, then drive the gear off flywheel, using care not to damage the flywheel.

Uniformly heat the flywheel gear to temperature which will expand gear to permit installation (temperature must not exceed 400°F.).

As soon as gear has been heated, install on flywheel with chamfered teeth toward engine side of flywheel.

**CAUTION:** NEVER heat starter gear to Red Heat as this will change metal structure.

### Installation

(All Except 292 cu. in. Engines)

1. Clean the mating surfaces of flywheel and crankshaft to make certain there are no burrs.
2. Install flywheel on crankshaft and position to align dowel hole of crankshaft flange and flywheel (fig. 30L).
3. Install flywheel retaining bolts and torque to specifications.

(292 cu. in. Engine)

1. Clean the mating surfaces of flywheel and crankshaft to make certain there are no burrs.
2. Install flywheel on crankshaft and position to align dowel holes of crankshaft flange and flywheel.
3. Install flywheel retaining bolts and torque to specifications.

NOTE: The interference fit dowel pins used on 292 cu. in. engines must be replaced with an oversize dowel pin when installing the flywheel.

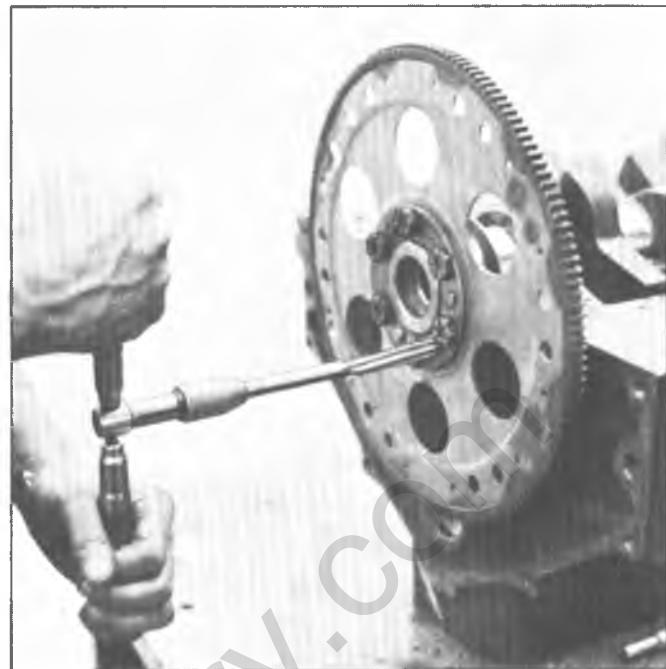

Fig. 31L—Reaming Flywheel Dowel Pin Holes

4. When installing the original flywheel, ream the dowel pin holes with Tool J-22808-2. When installing a new flywheel, first ream the dowel pin holes with Tool J-22808-2 and then finish reaming them with Tool J-22808-1 (fig. 31L).
5. Install oversize dowel pins flush with flywheel retaining bolt surface.
6. Install rear main bearing cap and torque bolts to specifications. Install oil pan with new gaskets and seals. Torque oil pan retaining screws to specifications.

### Engine Mounts

Engine mounts (fig. 32L-38L) are the non-adjustable type and seldom require service. Broken or deteriorated mounts should be replaced immediately, because of the added strain placed on other mounts and drive line components.

#### Checking Engine Mounts

##### Front Mount

Raise the engine to remove weight from the mounts and to place a slight tension in the rubber. Observe both mounts while raising engine. If an engine mount exhibits:

- a. Hard rubber surface covered with heat check cracks;
- b. Rubber separated from a metal plate of the mount; or
- c. Rubber split through center.

Replace the mount, if there is relative movement between a metal plate of the mount and its attaching

points, lower the engine on the mounts and tighten the screws or nuts attaching the mount to the engine, frame, or bracket.

### **Rear Mount**

Raise the vehicle on a hoist. Push up and pull down on the transmission tailshaft while observing the transmission mount. If the rubber separates from the metal plate of the mount or if the tailshaft moves up but not down (mount bottomed out) replace the mount. If there is relative movement between a metal plate of the mount and its attaching point, tighten the screws or nuts attaching the mount to the transmission or crossmember.

### **Front Mount Replacement**

#### **C, K and P Series**

1. Remove frame bracket to mount bolt.
2. Raise engine enough to clear mount.
3. Remove mount and install new mount.
4. Install new mount and torque bolts to specifications.
5. Lower engine then install frame bracket to mount bolt and torque to specifications.

#### **G Series**

1. Raise vehicle on hoist.
2. On manual transmission equipped vehicles.
  - a. Disconnect clutch rod at outboard lever on clutch cross shaft.
  - b. Remove the two bolts securing clutch cross shaft bracket to frame side rail, and position clutch linkage away from engine mount.
3. Remove mount-to-bracket through-bolt.
4. Raise engine sufficiently to clear mount. Remove bolts securing mount to frame bracket.
5. Install new mount to frame bracket, and torque bolts to specifications.
6. Lower engine to align mount with engine bracket. Install through bolt and torque to specifications.
7. On manual transmission equipped vehicles.
  - a. Position clutch cross shaft between frame side rail and ball stud on engine bracket. Install and torque frame bolts.
  - b. Connect clutch rod at outboard lever on clutch cross shaft.
8. Lower vehicle on hoist and check operation of clutch.

### **Rear Mount Replacement**

#### **C, K and P Series**

1. Raise and support vehicle.
2. Bend mount bolt french lock tabs away from bolt head, then remove mount bolts, lower mount and spacer.
3. Raise engine enough to clear upper mount assembly and remove upper mount from frame member.

NOTE: On models using a propeller shaft brake of any type, it is necessary to remove screws from transmission hole cover to allow the engine to raise because of the limited clearance between the brake and transmission hole cover.

4. Place new upper mount in place on frame member, then lower engine to within 1/4 inch of mount.
5. Align mount so that guide dowel enters hole in mount, install bolt through french lock, lower mount and spacer, then install bolt up through frame, upper mount and thread into engine bell housing loosely.
6. Lower engine completely and tighten mount bolt, then bend tabs of french lock to lock the bolt in place.

#### **G Series**

1. Raise vehicle on hoist and support transmission so as not to interfere with support crossmember removal.
2. Remove bolts securing rear mount to support crossmember.
3. Remove support crossmember retaining bolts from underbody cross rail and withdraw support from vehicle.
4. Remove bolts securing mount to transmission extension.
5. Install new rear mount and torque bolts to specifications.
6. Position support crossmember to cross rail, install bolts then loosely install crossmember-to-mount retaining bolts.
7. Remove support from rear of transmission, torque remaining bolts to specifications and lower vehicle on hoist.

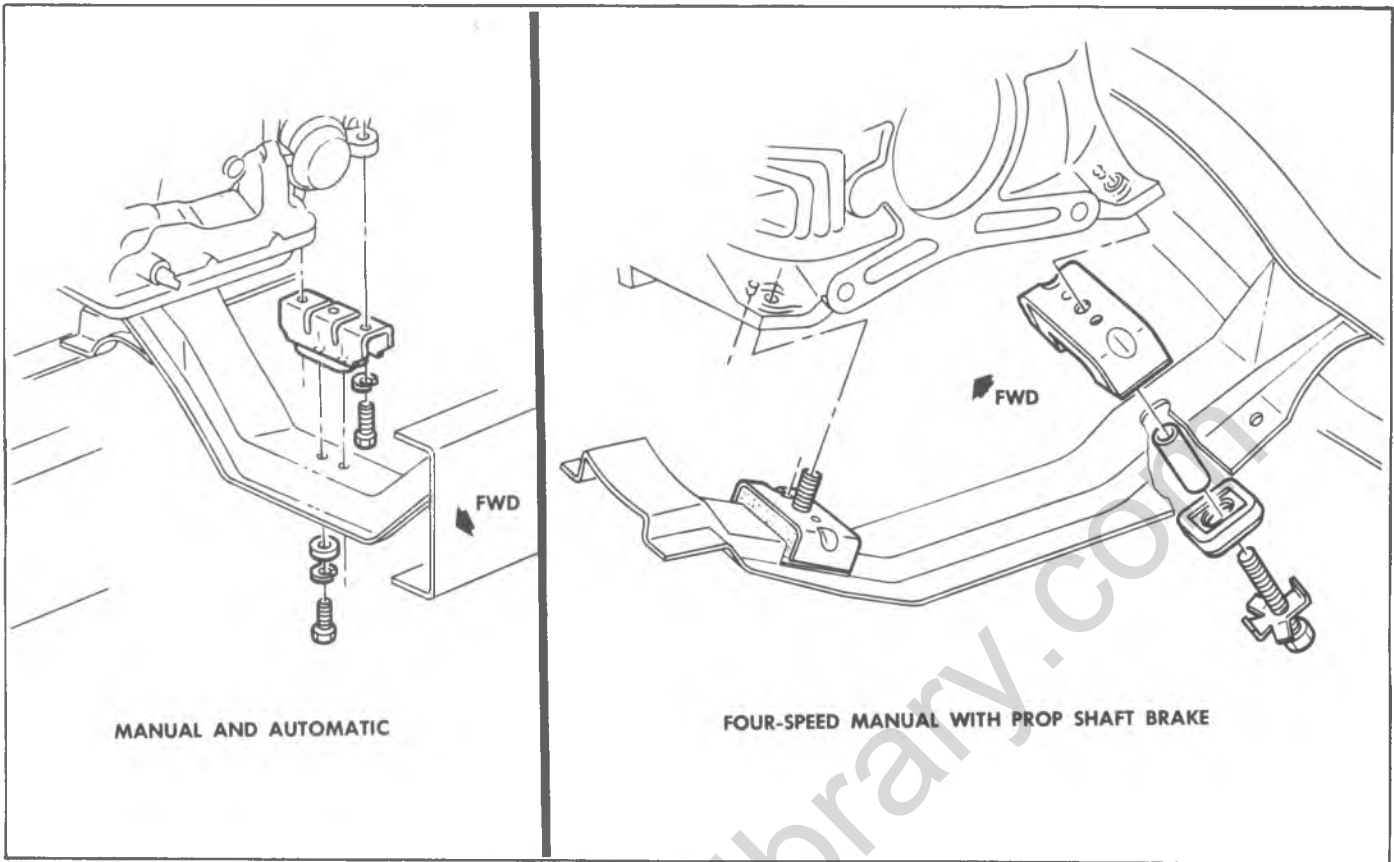

Fig. 32L—P Series Engine Rear Mount



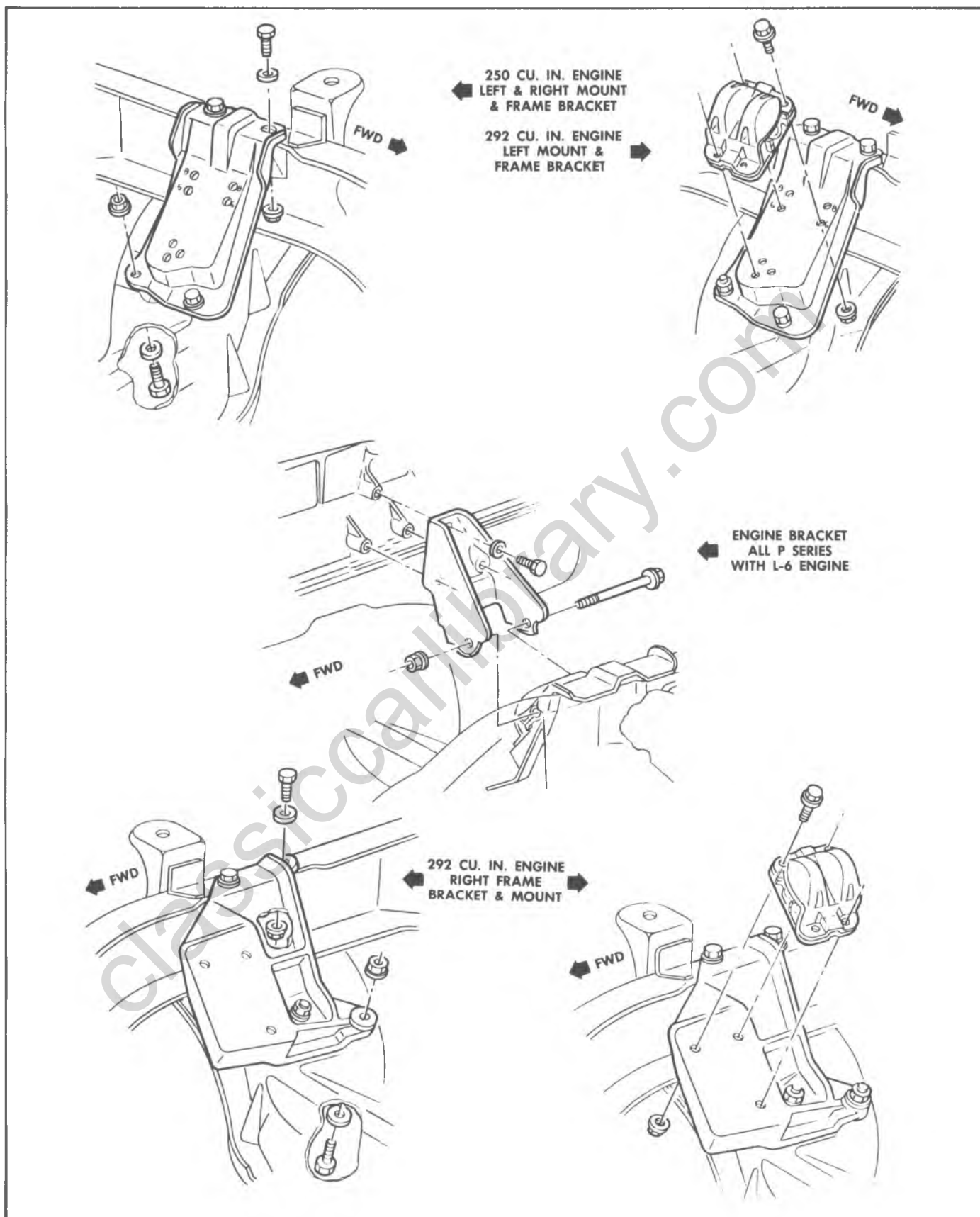

Fig. 33L—P Series Engine Front Mount

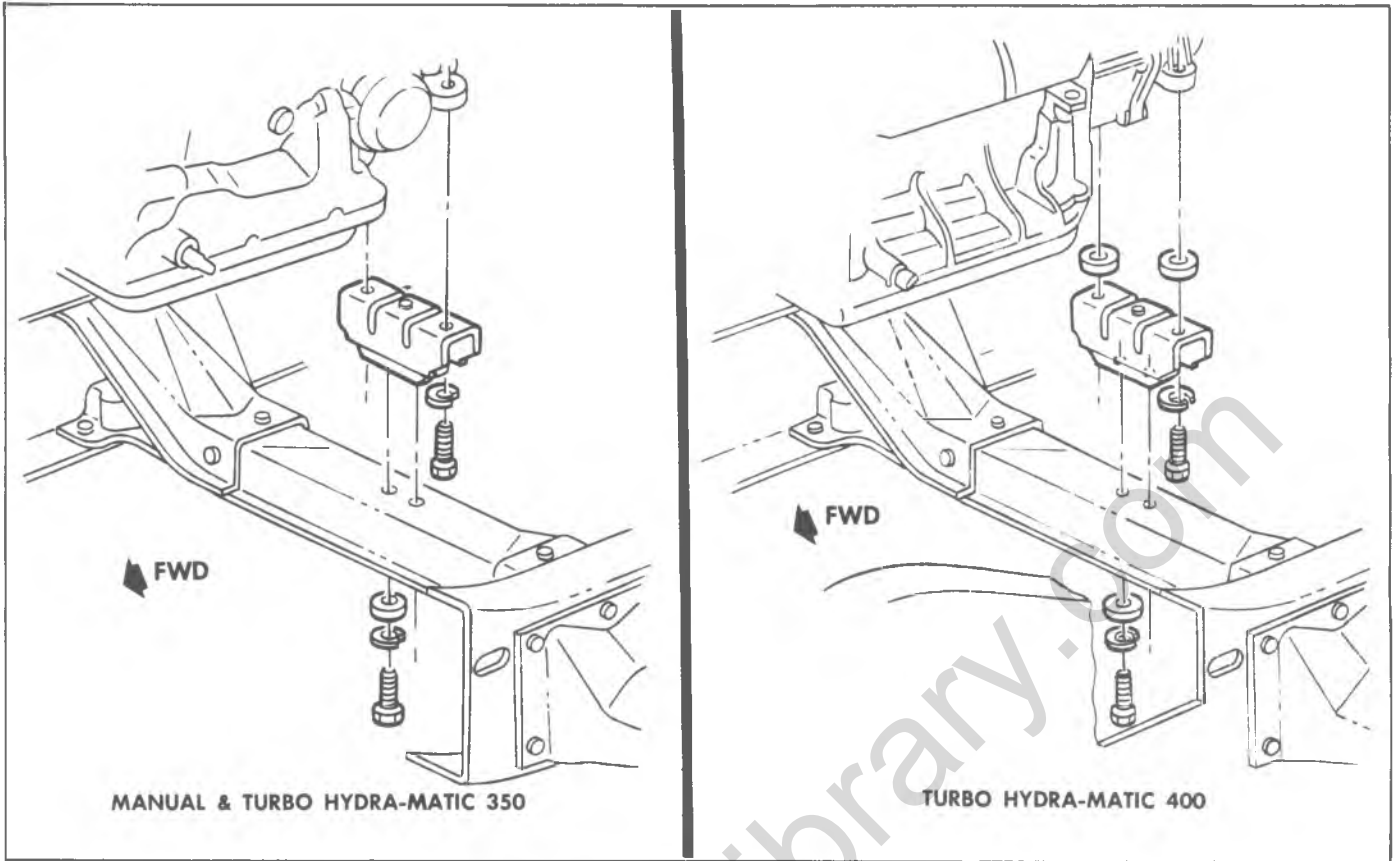

Fig. 34L-C Series Engine Rear Mount

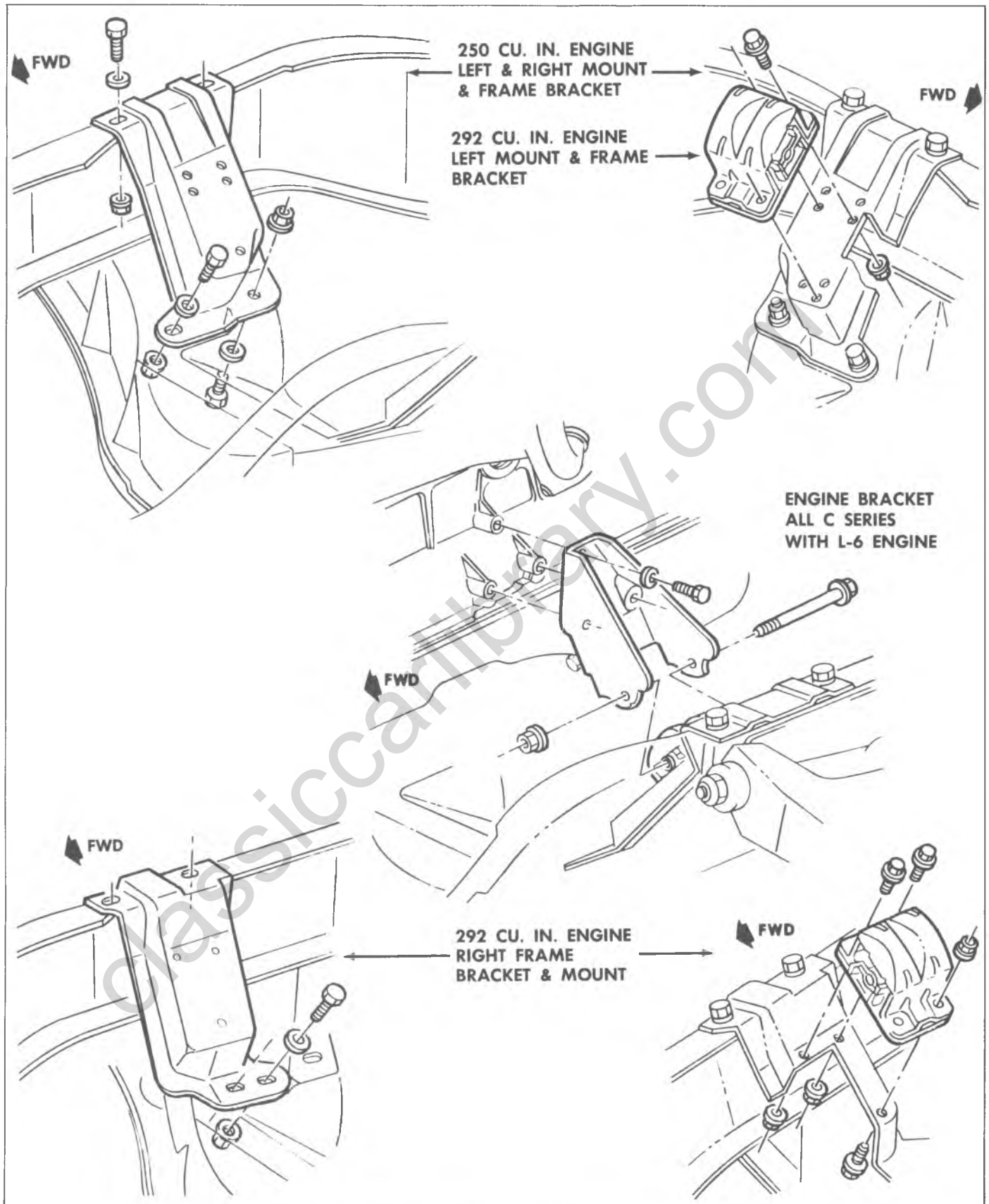

Fig. 35L—C Series Engine Front Mount

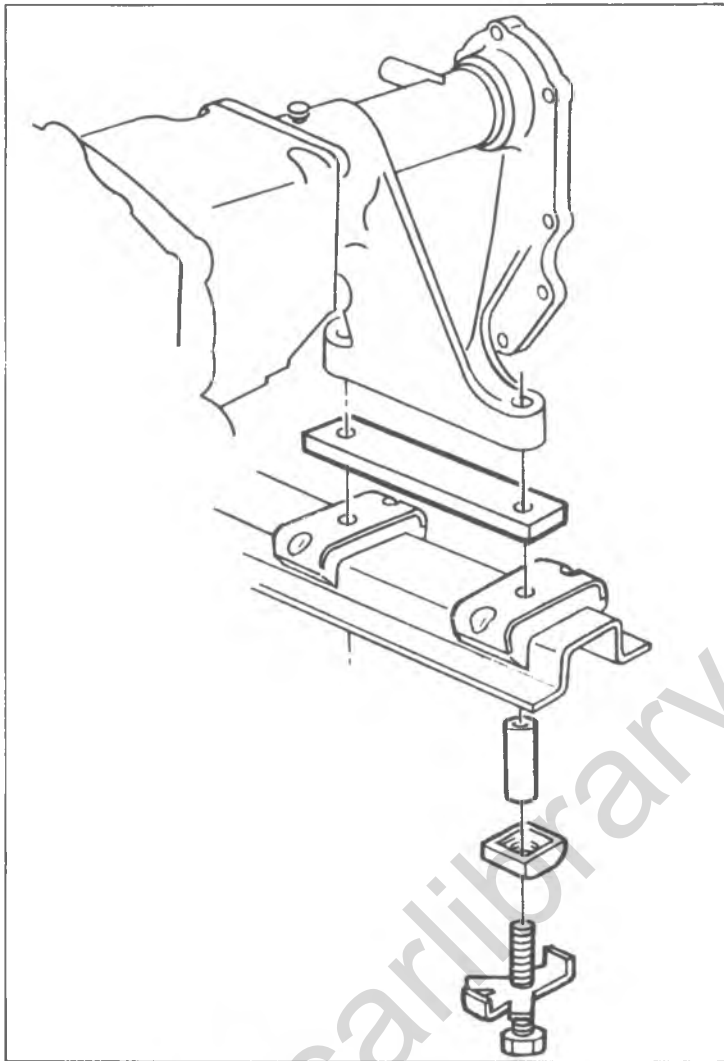

Fig. 36L-K Series Engine Rear Mount

classiccarlibrary.com

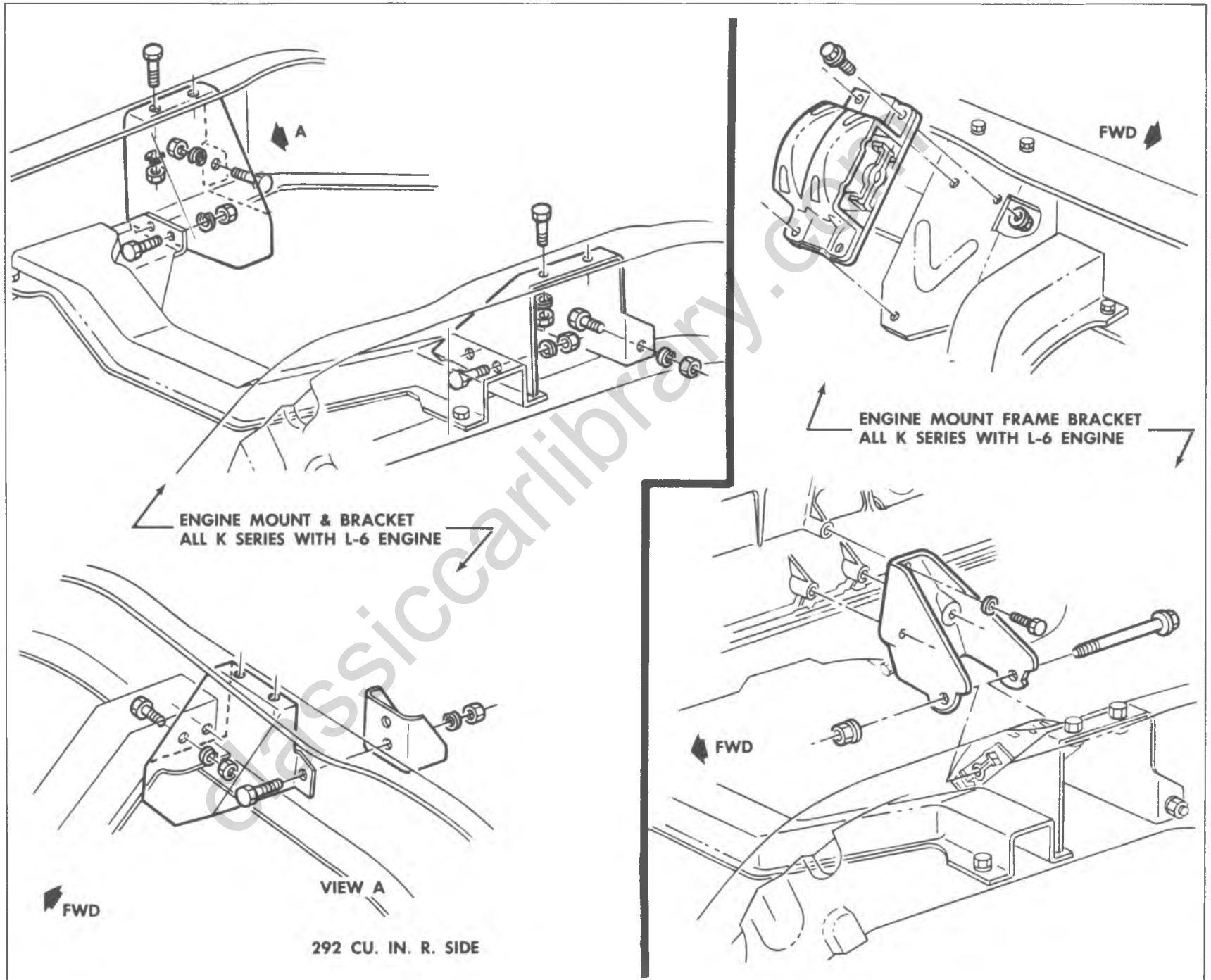

Fig. 37L—K Series Engine Front Mount

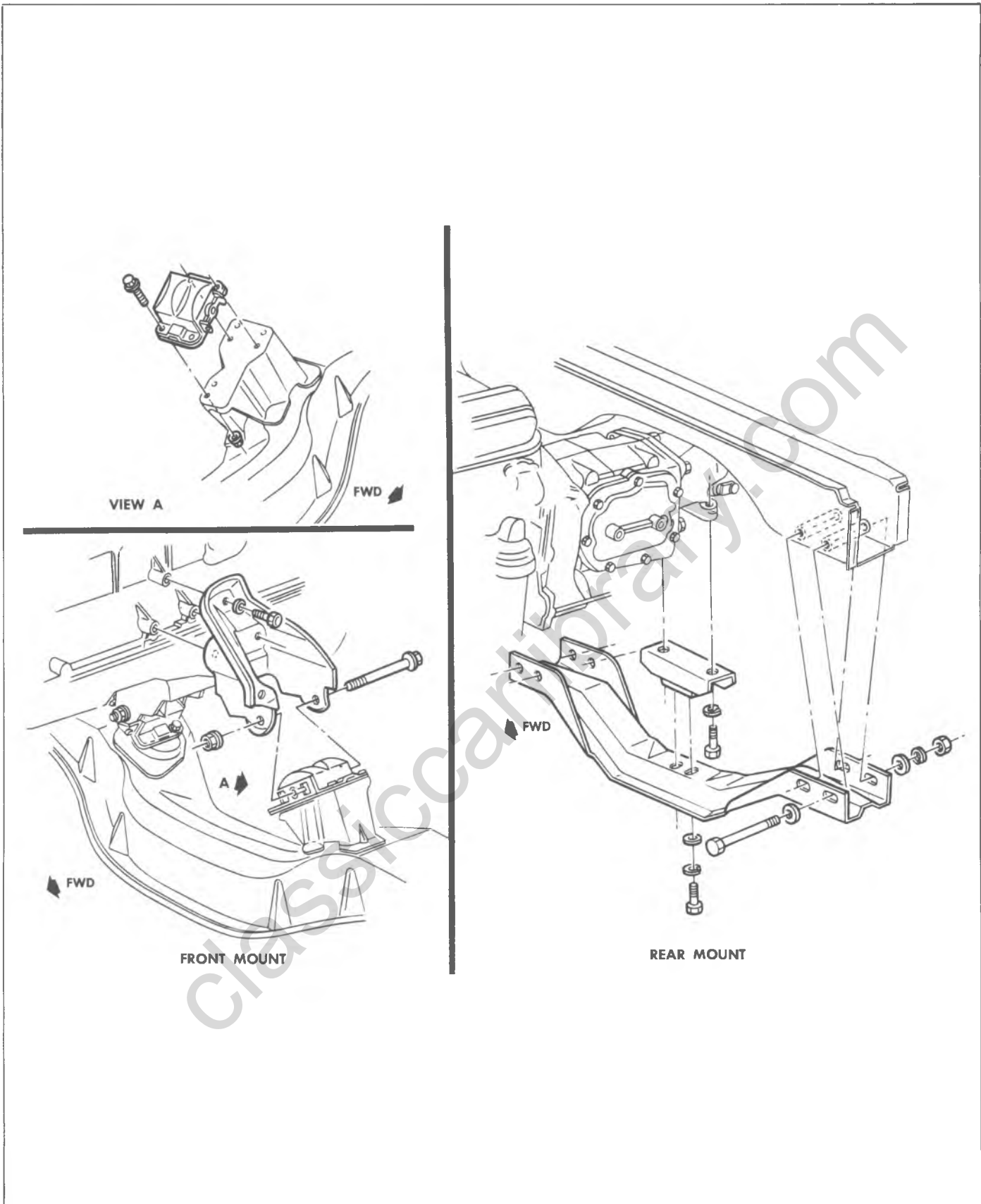

Fig. 38L-G Series Engine Mounts

# ENGINE MECHANICAL

## V-8 ENGINES

### INDEX

General Description .....	6-45	Installation .....	6-54
Component Replacement and Adjustment .....	6-45	Oil Pump .....	6-54
Engine Assembly .....	6-45	Removal .....	6-54
Removal .....	6-45	Installation .....	6-54
Installation .....	6-48	Oil Seal (Rear Main) .....	6-54
Intake Manifold .....	6-50	Replacement .....	6-54
Removal .....	6-50	Torsional Damper .....	6-55
Installation .....	6-50	Removal .....	6-55
Exhaust Manifold .....	6-50	Installation .....	6-55
Removal .....	6-50	Crankcase Front Cover .....	6-56
Installation .....	6-50	Removal .....	6-56
Rocker Arm Cover .....	6-51	Installation .....	6-56
Removal .....	6-51	Oil Seal (Front Cover) .....	6-57
Installation .....	6-51	Replacement .....	6-57
Valve Mechanism .....	6-51	Timing Chain and/or Sprockets .....	6-58
Removal .....	6-51	Replacement .....	6-58
Installation and Adjustment .....	6-51	Camshaft .....	6-58
Valve Lifters .....	6-51	Measuring Lobe Lift .....	6-58
Locating Noisy Lifters .....	6-51	Removal .....	6-60
Removal .....	6-52	Installation .....	6-60
Installation .....	6-52	Flywheel .....	6-60
Valve Stem Oil Seal and/or Valve Spring .....	6-52	Removal .....	6-60
Replacement .....	6-52	Repair .....	6-60
Cylinder Head Assembly .....	6-53	Installation .....	6-60
Removal .....	6-53	Engine Mounts .....	6-60
Installation .....	6-53	Checking Engine Mounts .....	6-60
Oil Pan .....	6-53	Replacement (Front) .....	6-61
Removal .....	6-53	Replacement (Rear) .....	6-61

### GENERAL DESCRIPTION

The V8 engines covered in this section are the 350, and 454 cu. in. engines used in 10-30 Series truck vehicles. In order to avoid repetition and to identify the engines involved in a particular procedure, the 350 cu. in. V8 engines are identified as "Small V8's". The 454 cu. in. engine is identified as "Mark IV V8".

This section covers the removal and installation of engine assemblies; the removal, installation and adjustment of some sub-assemblies and replacement of some components. For service to all components and sub-assemblies (after removal) and removal of some sub-

assemblies, refer to Section 6 of the Chassis Overhaul Manual.

Because of the interchangeability and similarity of many engines, engine sub-assemblies and parts regardless of which truck vehicle they are used in, typical illustrations and procedures are used (except where specific illustrations or procedures are necessary to clarify the operation). Although illustrations showing bench operations are used, most single operations, when not part of a general overhaul, should be performed (if practical) with the engine in the vehicle.

### COMPONENT REPLACEMENT AND ADJUSTMENT

#### Engine Assembly

##### Removal

##### C, K and P Series

1. Disconnect battery cables and drain cooling system.
2. Remove the air cleaner.

3. Perform the following preliminary operations:

- Remove the hood as outlined in Section 11.
- Remove the radiator and shroud as outlined in Section 13.

## 6-46 ENGINE

4. Disconnect wires at:
  - TCS Solenoid (if so equipped)
  - Starter Solenoid
  - Delcotron
  - Temperature Switch
  - Oil Pressure Switch
  - Coil
5. Disconnect:
  - Accelerator linkage at manifold bellcrank
  - Fuel line (from tank) at fuel pump.
  - Heater hoses at engine connection.
  - Oil pressure gauge line (if so equipped).
  - Vacuum or air lines at engine (as required).
  - Power steering pump with hoses attached and lay aside (if so equipped).
  - Ground straps at engine.
  - Exhaust pipe at manifold.
  - TCS switch at transmission (if so equipped).

NOTE: Hang exhaust pipe at frame with wire.

6. Remove fan and pulley as outlined in Section 6K.
7. Remove clutch cross-shaft.
8. Perform the following operations:
9. Attach lifting device to engine lift brackets and take weight off engine mounts.

### ON ALL SERIES EXCEPT CE 10-20-30:

- Support transmission and disconnect from engine.
- Disconnect speedometer cable at transmission.
- Disconnect shift linkage at transmission.
- Disconnect clutch linkage (as required).
- Remove engine mount bolts.

10. Remove engine from vehicle as follows:

**CAUTION:** Check often during engine removal to be sure all necessary disconnects have been made.

### ON CE 10-20-30 SERIES:

- On vehicles with automatic or four speed transmissions, remove rear mount crossmember.
- Raise engine and transmission assembly and pull forward until removed.

### ON KE 10-20 SERIES:

- Raise engine and pull forward until disconnected from transmission.
- Continue to raise engine until removed from vehicle.

11. If engine is to be mounted in an engine stand perform the following:

### ON CE 10-20-30 SERIES:

- Remove synchromesh transmission and clutch (if so equipped).
  - a. Remove clutch housing rear cover bolts.
  - b. Remove bolts attaching the clutch housing to engine block then remove transmission and clutch housing as a unit.

NOTE: Support the transmission as the last mounting bolt is removed and as it is being pulled away from the engine, to prevent damage to clutch disc.

- c. Remove starter and clutch housing rear cover.
  - d. Loosen clutch mounting bolts a turn at a time (to prevent distortion of clutch cover) until the spring pressure is released. Remove all bolts, clutch disc and pressure plate assembly.
- Remove automatic transmission (if so equipped).
    - a. Lower engine, secured by the hoist, and support engine on blocks.
    - b. Remove starter and converter housing under pan.
    - c. Remove flywheel-to-converter attaching bolts.
    - d. Support transmission on blocks.
    - e. Disconnect throttle linkage and vacuum modulator line.
    - f. Remove transmission-to-engine mounting bolts.
    - g. With the hoist attached, remove blocks from the engine only and slowly guide the engine from the transmission.

### ON ALL SERIES EXCEPT CE10-20-30:

- Remove clutch housing.
- Loosen clutch mounting bolts a turn at a time (to prevent distortion of clutch cover) until the spring pressure is released. Remove all bolts, clutch disc and pressure plate assembly.



12. Mount engine in engine stand and remove lifting device and lifting adapter.

### G Series

1. Remove vehicle grille as outlined in Section 13.
2. Drain cooling system and disconnect heater outlet hose at radiator and inlet hose at heater core tube.
3. Disconnect radiator lower hose at radiator; disconnect radiator upper hose at engine.
4. Disconnect automatic transmission cooler lines at radiator.
5. Remove fan shroud and radiator - position headlamp wiring out of the way.
6. Remove radiator upper tie bar and center support.
7. Disconnect battery cables at battery and at radiator support baffle - position cables over engine.
8. Disconnect engine wiring harness at dash mounted fuse panel; at cowl attachments, and position loose harness assembly on engine.
9. Disconnect oil pressure gauge, if so equipped.
10. Raise vehicle on a hoist and disconnect:
  - Fuel line (from tank) at fuel pump.
  - Engine ground strap(s).
  - Speedometer cable at transmission.
  - Exhaust pipe at manifolds.
  - Transmission at crossmember.
11. Disconnect clutch linkage and/or transmission linkage and remove cross shaft as outlined in Section 7.
12. Remove propeller shaft as outlined in Section 4 - install plug in transmission extension.
13. Remove engine mount-to-crossmember bracket attaching bolts (both sides of engine).
14. Remove engine mount through bolts; then raise engine and remove bracket and mount as an assembly.
15. Position blocks between engine mount brackets and crossmember to support engine; then lower engine onto supports.
16. Lower vehicle on hoist - heavy vehicle on hoist and approximately 12 inches off the floor.
17. Working from inside the vehicle - remove the engine access cover.
18. Remove the engine air cleaner assembly.
19. Disconnect power brake vacuum line at inlet manifold.
20. Disconnect linkage from carburetor throttle lever, disconnect carburetor fuel inlet line and remove carburetor and choke assembly from manifold.
21. Remove the two forward center inlet manifold bolts (numbers 3 and 4) (fig. 1V).

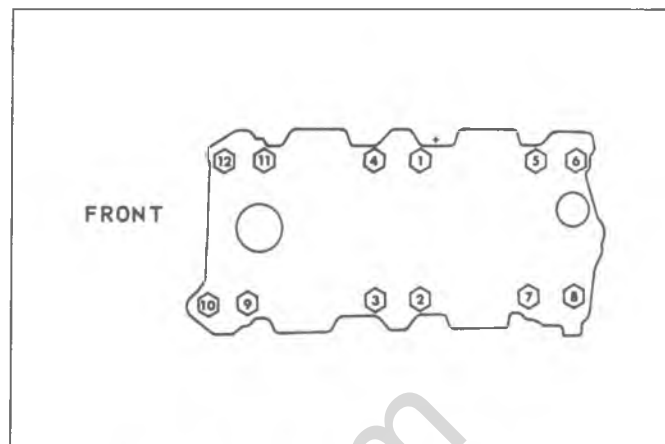

Fig. 1V—Inlet Manifold Attaching Bolts

22. Position Tool J-24680-1 (fig. 2V) to the engine and install with provided bolts (fig. 3V).
23. Attach lifting device to Tool J-24680-1, and with the



Fig. 2V—Engine Lifting Tool J-24680-1



Fig. 3V—Tool J-24680-1 Installed on Engine

aid of an assistant inside the vehicle, raise the engine while moving the engine assembly forward and out of the vehicle (fig. 4V).

**CAUTION:** Check often when removing the engine to make sure that all disconnects have been made, and that engine does not interfere with surrounding components as it is being withdrawn from vehicle.

24. Remove synchromesh transmission and clutch (if so equipped).

- a. Remove clutch housing rear cover bolts.
- b. Remove bolts attaching the clutch housing to engine block, then remove transmission clutch housing as a unit.

**NOTE:** Support the transmission as the last mounting bolt is removed and as it is being pulled away from the engine, to prevent damage to clutch disc.

- c. Remove starter and clutch housing rear cover.
  - d. Loosen clutch mounting bolts a turn at a time (to prevent distortion of clutch cover) until the spring pressure is released. Remove all bolts, clutch disc and pressure plate assembly.
25. Remove automatic transmission (if so equipped).
- a. Lower engine secured by the hoist, and support engine on blocks.
  - b. Remove starter and converter housing underpan.
  - c. Remove flywheel-to-converter attaching bolts.
  - d. Support transmission on blocks.
  - e. Disconnect throttle linkage and detent cable on Turbo Hydra-Matic.

- f. Remove transmission-to-engine mounting bolts.
- g. With the hoist attached, remove blocks from the engine only and slowly guide the engine away from the transmission.

### Installation

1. If engine was mounted in an engine stand, attach lifting adapter to engine then using lifting device, remove engine from stand and perform the following:

#### ON CE 10-20-30:

- Install synchromesh transmission and clutch (if so equipped).
  - a. Install the clutch assembly on flywheel as outlined in Section 7.
  - b. Install clutch housing rear cover and starter.
  - c. Install the transmission and clutch housing as outlined in Section 7.
  - d. Install clutch housing rear cover bolts and torque to specifications.
- Install automatic transmission (if so equipped).
  - a. Position engine adjacent to the transmission and align the converter with the flywheel.
  - b. Bolt transmission to engine then raise engine and transmission assembly and install flywheel to converter bolts.
  - c. Install converter housing underpan and starter.
  - d. Connect throttle linkage and vacuum modulator line.

#### ON ALL SERIES EXCEPT CE 10-20-30:

- Install clutch assembly and clutch housing as outlined in Section 7.

2. Install engine in vehicle as follows:

#### ON ALL SERIES EXCEPT CE 10-20-30:

- Install engine and lower until transmission lines up with clutch.
- Push engine rearward and rotate crankshaft until transmission shaft and clutch engage.
- Install the engine mount bolts and torque to specifications.
- Connect transmission to engine.

#### ON CE 10-20-30 SERIES:

- Lower engine and transmission assembly and push rearward until engine mounts line up.
- On vehicles with automatic or four speed transmissions, install rear mount crossmember.
- Install the engine mount bolts and torque to specifications.
- Install the propeller shaft as outlined in Section 4.

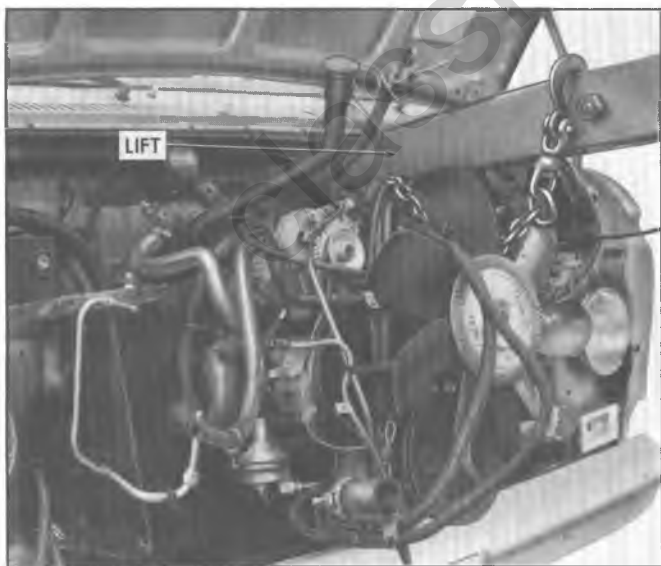

Fig. 4V—Removing Engine Assembly

**ON ALL SERIES:**

- Remove the lifting device from engine lift brackets.
3. Connect transmission linkage (as required).
  4. Install clutch cross-shaft.
  5. Install fan and pulley as outlined in Section 6K.
  6. Connect:
    - Exhaust pipe at manifold.
    - Power steering pump (as required).
    - Vacuum lines at engine (as required).
    - Oil pressure gauge line (as required).
    - Heater hoses at engine connection.
    - Fuel line at fuel pump.
    - Choke cable at carburetor.
    - Accelerator linkage at manifold bellcrank.
    - TCS switch at transmission.
  7. Connect wires at:
    - Coil
    - Oil Pressure Switch
    - Temperature Switch
    - Delcotron
    - Starter Solenoid
    - CEC Solenoid
  8. Complete installations as follows:
    - Install the radiator and shroud as outlined in Section 13.
    - Install the hood as outlined in Section 11.
  9. Install the air cleaner, connect battery cables, fill cooling system and crankcase then start engine and check for leaks.

**G Series**

1. If engine was mounted in an engine stand, attach Tool J-24680-1 to engine (fig. 3V), then using lifting device, remove engine from stand and perform the following.
  - Install manual transmission and clutch (if so equipped).
  - a. Install the clutch assembly on flywheel as outlined in Section 7.
  - b. Install clutch housing rear cover and starter.
  - c. Install the transmission and clutch housing as outlined in Section 7.
  - d. Install clutch housing rear cover bolts and torque to specifications.
    - Install automatic transmission (if so equipped).
  - a. Position engine adjacent to the transmission and align converter with the flywheel.
  - b. Bolt transmission to engine then raise engine and transmission assembly and install flywheel to converter bolts.
- c. Install converter housing underpan and starter.
- d. Connect throttle valve linkage and vacuum modulator. Connect detent cable on Turbo Hydra-Matic.
2. Raise engine assembly, and with the aid of an assistant, guide the engine assembly into position within the vehicle.
3. Position blocks between engine mount brackets and crossmember to support engine; then lower engine onto supports.
4. Remove lifting device from Tool J-24608-1.
5. Raise vehicle on a hoist, support engine and install the engine mount and crossmember bracket; install and torque mount through bolts.
6. Connect the following components:
  - Transmission at crossmember.
  - Exhaust pipe at manifolds.
  - Speedometer cable at transmission.
  - Engine ground strap(s).
  - Fuel line (from tank) at fuel pump.
7. Connect clutch linkage and/or transmission linkage and cross shaft as outlined in Section 7.
8. Remove plug from transmission extension and install propeller shaft as outlined in Section 4.
9. Lower vehicle on a hoist.
10. Connect oil pressure gauge, if so equipped.
11. Connect engine wiring harness at cowl attachments and at dash mounted fuse panel.
12. Install radiator upper tie bar and center support.
13. Install radiator, radiator shroud and headlamp wiring harness.
14. Connect transmission cooler lines at radiator.
15. Connect radiator hoses and heater hoses, connect coolant recovery hose to radiator overflow tube.
16. Install vehicle grille as outlined in Section 13.
17. Working from inside the vehicle, install power brake vacuum line at inlet manifold.
18. Remove tool J-25680-1 from inlet manifold and install and torque the two inlet manifold bolts.
19. Install carburetor to manifold and connect idle stop solenoid electrical lead, throttle linkage and fuel inlet line.
20. Install air cleaner assembly.
21. Connect battery cables to battery and to radiator baffle.
22. Check engine oil level (add oil if required) fill coolant system start engine and check and adjust to ensure proper operation.

23. Install the engine access cover.

## Intake Manifold

### Removal

1. Drain radiator and remove air cleaner.
2. Disconnect:
  - Battery cables at battery.
  - Radiator upper hose and heater hose at manifold.
  - Water pump by-pass at water pump.
  - Accelerator linkage at pedal lever.
  - Fuel line and choke cable at carburetor.
  - Crankcase ventilation lines (as required).
  - Spark advance hose and governor line (if so equipped) at distributor.
3. Remove distributor cap and mark rotor position with chalk, then remove distributor.
4. Remove (as required) oil filler bracket, air cleaner bracket, air compressor and bracket, coil, accelerator return spring and bracket, and accelerator bellcrank.
5. Remove manifold attaching bolts, then remove manifold and carburetor as an assembly. Discard gaskets and seals.
6. If manifold is to be replaced, transfer:
  - Carburetor and carburetor attaching bolts.
  - Temperature sending unit.
  - Water outlet and thermostat (use new gasket).
  - Heater hose and water pump by-pass adapters.
  - EGR Valve (use new gasket).

### Installation

1. Clean gasket and seal surfaces on manifold, block, and cylinder heads.
2. Install manifold seals on block and gaskets on cylinder heads (fig. 5V). Use sealer at water passages and where seals butt to gaskets.
3. Install manifold and torque bolts to specifications in the sequence outlined on the torque sequence chart.
4. Install (if removed) oil filler bracket, air cleaner bracket, air compressor and bracket, coil, accelerator return spring and bracket and accelerator bellcrank.
5. Install distributor, positioning rotor at chalk mark, then install distributor cap.
6. Connect:
  - Spark advance hose and governor line (if so equipped) at distributor.
  - Crankcase ventilation lines (as required).
  - Fuel line and choke cable at carburetor.

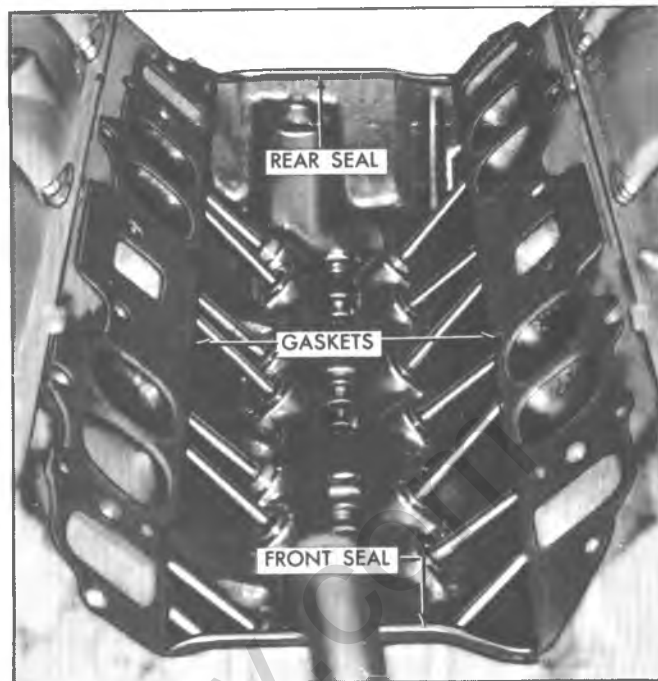

Fig. 5V—Intake Manifold Gasket and Seal Location

- Accelerator linkage at pedal lever.
  - Water pump by-pass at water pump (use new gasket).
  - Battery cables at battery.
7. Adjust choke cable and accelerator linkage as outlined.
  8. Install air cleaner.
  9. Fill with coolant, start engine, adjust ignition timing and carburetor idle speed and check for leaks.

## Exhaust Manifold

### Removal

1. On vehicles so equipped, remove carburetor heater.
2. On Small V8 engine, remove the spark plug wiring heatshields.
3. On "Mark IV V8" engines, remove spark plugs.
4. Disconnect exhaust pipe from manifold and hang exhaust pipe from frame with wire.
5. Remove end bolts then remove center bolts and remove manifold.

### Installation

1. Clean mating surfaces on manifold and head, then install manifold in position and install bolts (finger-tight).
2. Torque manifold bolts to specifications in the sequence shown on torque chart at end of section.
3. Connect exhaust pipe to manifold. Use new gasket or packing.

4. On "Mark IV V8" engines, install spark plugs. Torque plugs to specifications.
  5. On vehicles so equipped, install carburetor heater.
  6. On Small V8 engine, install spark plug wiring heatshields.
  7. Start engine and check for leaks.
3. Adjust valves when lifter is on base circle of camshaft lobe as follows:
    - a. Crank engine until mark on torsional damper lines up with center or "O" mark on the timing tab fastened to the crankcase front cover and the engine is in the number 1 firing position. This may be determined by placing fingers on the number 1 valve as the mark on the damper comes near the "O" mark on the crankcase front cover. If the valves are not moving, the engine is in the number 1 firing position. If the valves move as the mark comes up to the timing tab, the engine is in number 6 firing position and should be turned over one more time to reach the number 1 position.
    - b. With the engine in the number 1 firing position as determined above, the following valves may be adjusted.
 

Exhaust — 1, 3, 4, 8  
Intake — 1, 2, 5, 7
    - c. Back out adjusting nut until lash is felt at the push rod then turn in adjusting nut until all lash is removed. This can be determined by checking push rod side play while turning adjusting nut (fig. 6V). When play has been removed, turn adjusting nut in one full additional turn (to center lifter plunger).
    - d. Crank the engine one revolution until the pointer "O" mark and torsional damper mark are again in alignment. This is number 6 firing position. With the engine in this position the following valves may be adjusted.
 

Exhaust — 2, 5, 6, 7  
Intake — 3, 4, 6, 8

## Rocker Arm Cover

### Removal

1. Remove air cleaner.
2. Disconnect crankcase ventilation hoses at rocker arm covers.
3. Disconnect electrical wiring harness from left rocker arm clips.
4. On vehicles so equipped, remove carburetor heater from right exhaust manifold.
5. Remove rocker arm cover.

**CAUTION:** Do not pry rocker arm cover loose. Gaskets adhering to cylinder head and rocker arm cover may be sheared by bumping end of rocker arm cover rearward with palm of hand or a rubber mallet.

### Installation

1. Clean gasket surfaces on cylinder head and rocker arm cover with degreaser then, using a new gasket, install rocker arm cover and torque to specifications.
2. Install carburetor heater (if removed).
3. Connect electrical wiring harness at clips on left rocker arm cover.
4. Connect crankcase ventilation hoses (as required).
5. Install air cleaner, start engine and check for leaks.

## Valve Mechanism

### Removal

1. Remove rocker arm covers as outlined.
2. Remove rocker arm nuts, rocker arm balls, rocker arms and push rods.

**NOTE:** Place rocker arms, rocker arm balls and push rods in a rack so they may be reinstalled in the same locations.

### Installation and Adjustment

**NOTE:** Whenever new rocker arms and/or rocker arm balls are being installed, coat bearing surfaces of rocker arms and rocker arm balls with "Molykote" or its equivalent.

1. Install push rods. Be sure push rods seat in lifter socket.
2. Install rocker arms, rocker arm balls and rocker arm nuts. Tighten rocker arm nuts until all lash is eliminated.

## Valve Lifters

Hydraulic valve lifters very seldom require attention. The lifters are extremely simple in design, readjustments are not necessary, and servicing of the lifters requires only that care and cleanliness be exercised in the handling of parts.

### Locating Noisy Lifters

Locate a noisy valve lifter by using a piece of garden hose approximately four feet in length. Place one end of the hose near the end of each intake and exhaust valve with the other end of the hose to the ear. In this manner, the sound is localized making it easy to determine which lifter is at fault.

Another method is to place a finger on the face of the valve spring retainer. If the lifter is not functioning properly, a distinct shock will be felt when the valve returns to its seat.

The general types of valve lifter noise are as follows:

1. **Hard Rapping Noise**—Usually caused by the plunger becoming tight in the bore of the lifter body to such an extent that the return spring can no longer push the plunger back up to working position. Probable causes are:
  - a. Excessive varnish or carbon deposit causing abnormal stickiness.
  - b. Galling or “pick-up” between plunger and bore of lifter body, usually caused by an abrasive piece of dirt or metal wedging between plunger and lifter body.
2. **Moderate Rapping Noise**—Probable causes are:
  - a. Excessively high leakdown rate.
  - b. Leaky check valve seat.
  - c. Improper adjustment.
3. **General Noise Throughout the Valve Train**—This will, in most cases, be caused by either insufficient oil supply or improper adjustment.
4. **Intermittent Clicking**—Probable causes are:
  - a. A microscopic piece of dirt momentarily caught between ball seat and check valve ball.
  - b. In rare cases, the ball itself may be out-of-round or have a flat spot.
  - c. Improper adjustment.

In most cases where noise exists in one or more lifters all lifter units should be removed, disassembled, cleaned in a solvent, reassembled, and reinstalled in the engine. If dirt, corrosion, carbon, etc. is shown to exist in one unit, it more likely exists in all the units, thus it would only be a matter of time before all lifters caused trouble.

#### Removal

1. Remove intake manifold as outlined.
2. Remove valve mechanism as outlined.
3. Remove valve lifters.

**NOTE:** Place valve lifters in a rack so that they may be reinstalled in the same location.

#### Installation

1. Install valve lifters.

**NOTE:** Whenever new valve lifters are being installed, coat foot of valve lifters with “Molykote” or its equivalent.

2. Install intake manifold as outlined.
3. Install and adjust valve mechanism as outlined.

### Valve Stem Oil Seal and/or Valve Spring Replacement

#### Replacement

1. Remove rocker arm cover as outlined.
2. Remove spark plug, rocker arm and push rod on the cylinder(s) to be serviced.

3. Install air line adapter Tool J-23590 to spark plug port and apply compressed air to hold the valves in place.
4. Using Tool J-5892 to compress the valve spring, remove the valve locks, valve cap and valve spring and damper (fig. 7V).
5. Remove the valve stem oil seal.
6. Assemble as follows:

#### SMALL V8 ENGINES

- a. Set the valve spring and damper, valve shield and valve cap in place. Compress the spring with Tool J-5892 and install oil seal in the lower groove of the stem, making sure the seal is flat and not twisted.

**NOTE:** A light coat of oil on the seal will help prevent twisting.

- b. Install the valve locks and release the compressor tool making sure the locks seat properly in the upper groove of the valve stem.

**NOTE:** Grease may be used to hold the locks in place while releasing the compressor tool.

#### MARK IV V8 ENGINES

- a. Install new valve stem oil seal (coated with oil) in position over valve guide.

**NOTE:** Seal installation instructions are supplied with each service kit. Install seal following procedures outlined on the supplied instruction sheet.

- b. Set the valve spring and damper and valve cap in place.

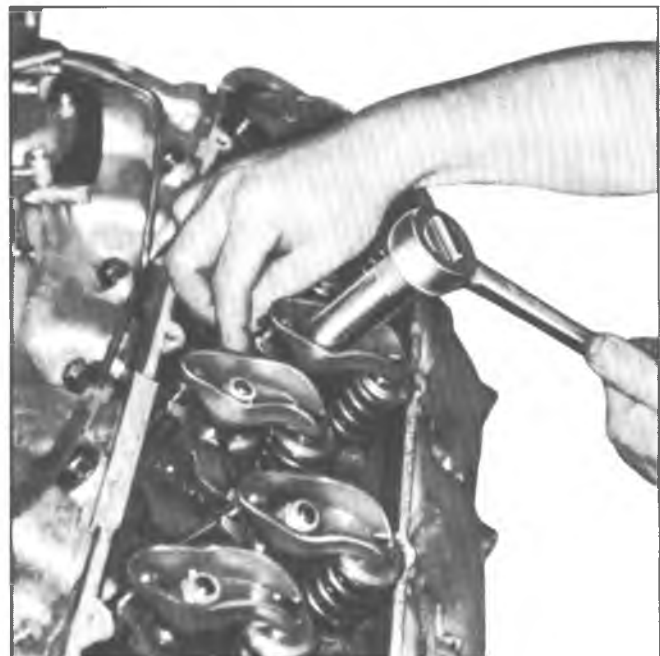

Fig. 6V—Valve Adjustment

- c. Compress the spring with Tool J-5892 and install the valve locks then release the compressor tool, making sure the locks seat properly in the groove of the valve stem.

**NOTE:** Grease may be used to hold the locks in place while releasing the compressor tool.

7. Install spark plug and torque to specifications.
8. Install and adjust valve mechanism as outlined.

## Cylinder Head Assembly

### Removal

1. Remove intake manifold as outlined.
2. Remove exhaust manifolds as outlined.
3. Remove valve mechanism as outlined.
4. Drain cylinder block of coolant.
5. Remove cylinder head bolts, cylinder head and gasket. Place cylinder head on two blocks of wood to prevent damage.

### Installation

**CAUTION:** The gasket surfaces on both the head and the block must be clean of any foreign matter and free of nicks or heavy scratches. Cylinder bolt threads in the block and threads on the cylinder head bolts must be clean. (Dirt will affect bolt torque).

1. On engines using a STEEL gasket, coat both sides of a new gasket with a good sealer. Spread the sealer thin and even. One method of applying the

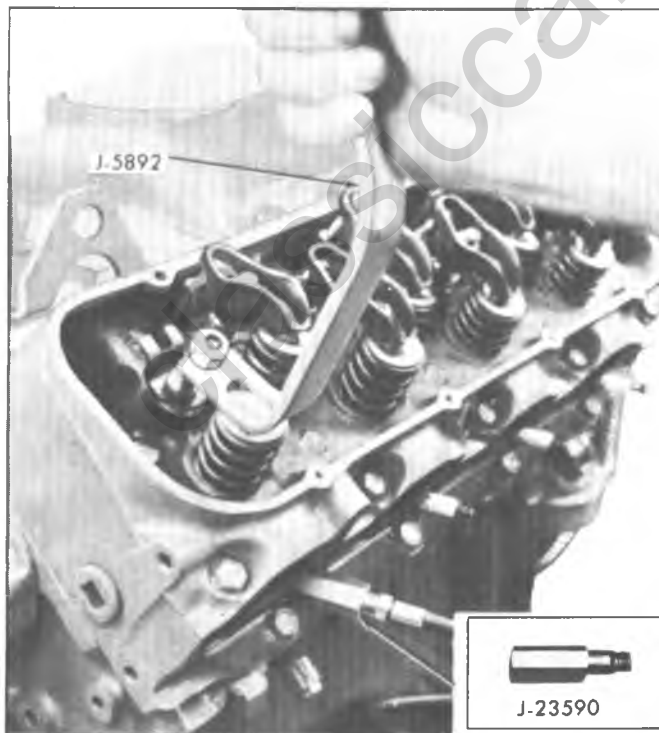

Fig. 7V—Compressing Valve Spring

sealer that will assure the proper coat is with the use of a paint roller. Too much sealer may hold the gasket away from the head or block.

**CAUTION:** Use no sealer on engines using a composition STEEL ASBESTOS gasket.

2. Place the gasket in position over the dowel pins with the bead up.
3. Carefully guide the cylinder head into place over the dowel pins and gasket.
4. Coat threads of cylinder head bolts with sealing compound and install bolts finger tight.
5. Tighten each cylinder head bolt a little at a time in the sequence shown in the torque sequence chart until the specified torque is reached.
6. Install exhaust manifolds as outlined.
7. Install intake manifold as outlined.
8. Install and adjust valve mechanism as outlined.

## Oil Pan

### Removal

1. Drain engine oil.

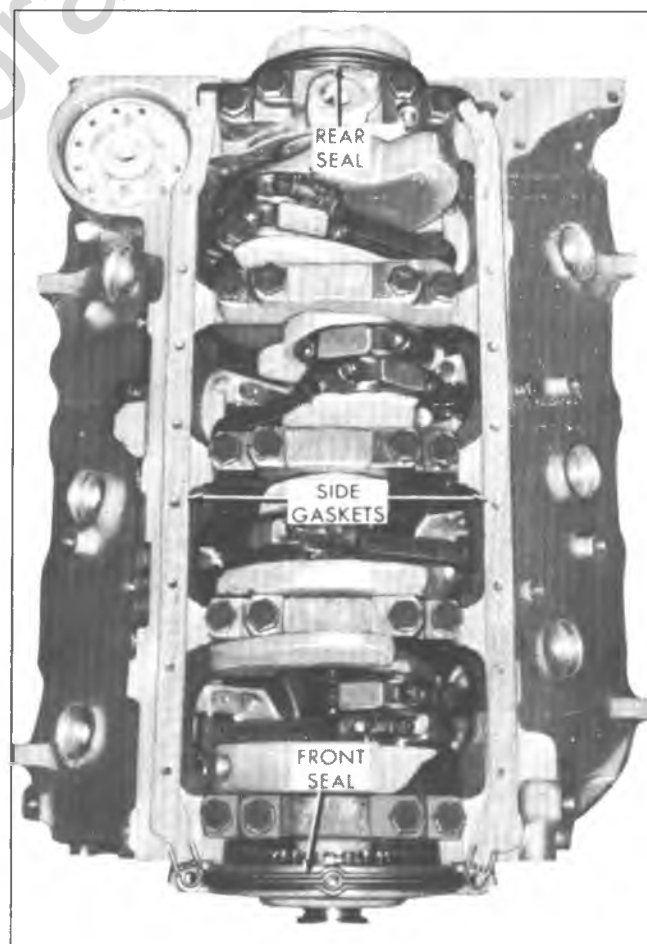

## 6-54 ENGINE

2. Remove oil dip stick and tube.
3. On vehicles so equipped remove exhaust crossover pipe.
4. On vehicles equipped with automatic transmission remove converter housing under pan.
5. Remove starter brace and inboard bolt, swing starter aside.
6. Remove oil pan and discard gaskets and seals.

### Installation

1. Thoroughly clean all gasket and seal surfaces on oil pan, cylinder block, crankcase front cover and rear main bearing cap.
2. Install new oil pan side gaskets on cylinder block using gasket sealer as a retainer. Install new oil pan rear seal in rear main bearing cap groove, with ends butting side gaskets. Install new oil pan front seal in groove in crankcase front cover with ends butting side gaskets (fig. 8V).
3. Install oil pan and torque bolts to specifications.
4. Install starter brace and attaching bolts. Torque bolts to specifications.
5. Install converter housing under pan (if removed).
6. Install exhaust crossover pipe (if removed).
7. Install oil dip stick tube and dip stick.
8. Fill with oil, start engine and check for leaks.

## Oil Pump

### Removal

1. Remove oil pan as outlined.
2. Remove pump to rear main bearing cap bolt and remove pump and extension shaft.

### Installation

1. Assemble pump and extension shaft to rear main bearing cap, aligning slot on top end of extension shaft with drive tang on lower end of distributor drive shaft.
2. Install pump to rear bearing cap bolt and torque to specifications.

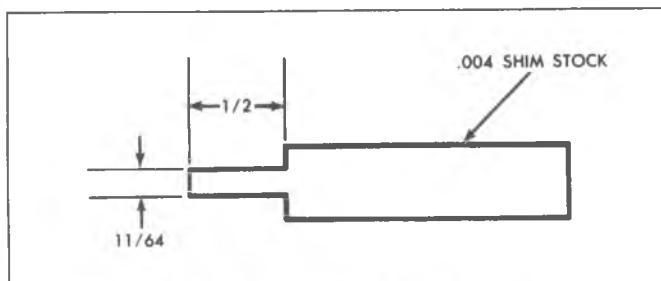

Fig. 9V—Oil Seal Installation Tool

NOTE: Installed position of oil pump screen is with bottom edge parallel to oil pan rails.

3. Install oil pan as outlined.

## Oil Seal (Rear Main)

### Replacement

NOTE: Always replace the upper and lower seal as a unit. Install seal with lip facing front of engine.

The rear main bearing oil seal can be replaced (both halves) without removal of the crankshaft. Extreme care should be exercised when installing this seal to protect the sealing bead located in the channel on the outside diameter of the seal. An installation tool (fig. 9V) can be used to protect the seal bead when positioning seal as follows:

1. With the oil pan and oil pump removed, remove the rear main bearing cap.
2. Remove oil seal from the bearing cap by prying from the bottom with a small screw driver (fig. 10V).
3. To remove the upper half of the seal, use a small hammer to tap a brass pin punch on one end of seal until it protrudes far enough to be removed with pliers (fig. 11V).
4. Clean all sealant and foreign material from cylinder case bearing cap and crankshaft, using a non-abrasive cleaner.
5. Inspect components for nicks, scratches, burrs and machining defects at all sealing surfaces, case assembly and crankshaft.
6. Coat seal lips and seal bead with light engine oil - keep oil off seal mating ends.
7. Position tip of tool between crankshaft and seal seat in cylinder case.



Fig. 10V—Removing Oil Seal (Lower Half)



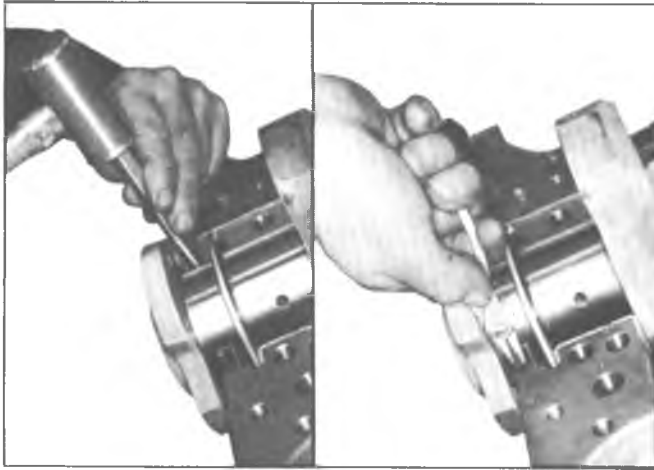

Fig. 11V—Removing Oil Seal (Upper Half)

8. Position seal between crankshaft and tip of tool so that seal bead contacts tip of tool.

**NOTE:** Make sure that oil-seal lip is positioned toward front of engine (fig. 12V).

9. Roll seal around crankshaft using tool as a "shoehorn" to protect seal bead from sharp corner of seal seat surface in cylinder case.

**CAUTION:** Installation tool must remain in position until seal is properly positioned with both ends flush with block.

10. Remove tool, being careful not to withdraw seal.
11. Install seal half in bearing cap, again using tool as a "shoehorn", feeding seal into cap using light pressure with thumb and finger.
12. Install bearing cap to case with sealant applied to the cap-to-case interface being careful to keep sealant off the seal split line (fig. 13V).

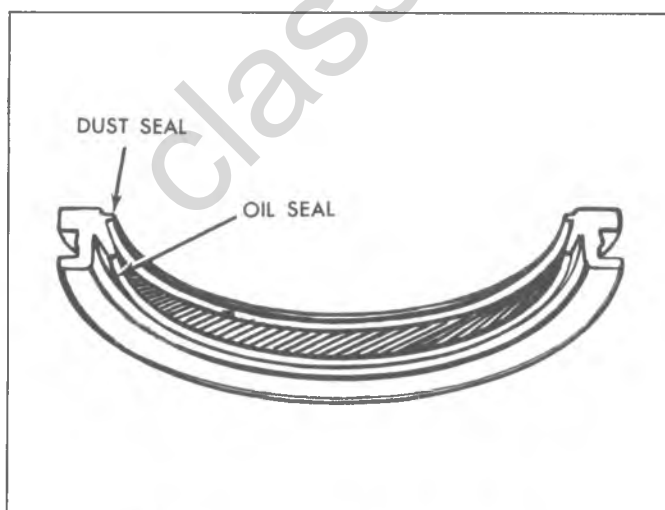

Fig. 12V—Crankshaft Oil Seal (Rear Main)

13. Install the rear main bearing cap (with new seal) and torque to specifications.

## Torsional Damper

### Removal

1. Remove fan belt, fan and pulley.
2. Remove the radiator shroud assembly as outlined in Section 13.

**NOTE:** If additional operations (such as camshaft removal) are not being performed, the radiator removal will not be necessary.

3. Remove accessory drive pulley then remove damper retaining bolt.
4. Install Tool J-23523 on damper then, turning puller screw, remove damper (fig. 14V).

**NOTE:** Tool J-23523 has holes forming two patterns. A two bolt and a three bolt pattern. The holes for the two bolt pattern must be elongated for use on the Mark IV V8 engines.

### Installation

**CAUTION:** The inertial weight section of the torsional damper is assembled to the hub with a rubber type material. The installation procedures (with proper tool) must be followed or movement of the inertia weight section on the hub will destroy the tuning of the torsional damper.

1. Coat front cover seal contact area (on damper) with engine oil.
  2. Place damper in position over key on crankshaft.
  3. Pull damper onto crankshaft as follows:
    - a. Install appropriate threaded end of Tool J-23523 into crankshaft.
- CAUTION:** Install tool in crankshaft so that at least 1/2" of thread engagement is obtained.
- b. Install plate, thrust bearing and nut to complete tool installation.
  - c. Pull damper into position as shown in Figure 15V.
  - d. Remove tool from crankshaft then install damper retaining bolt and torque to specifications.

4. Install accessory drive pulley.
5. Install radiator shroud as outlined in Section 13.
6. Install fan and pulley to water pump hub and tighten securely.
7. Install fan belt and adjust to specifications using strand tension gauge.
8. Fill cooling system, start engine and check for leaks.

## Crankcase Front Cover

### Removal

#### Small V8 Engine

1. Remove torsional damper as outlined.
2. Remove water pump as outlined in Section 6K.
3. Remove crankcase front cover attaching screws and remove front cover and gasket, then discard gasket.

#### Mark IV V8 Engine

1. Remove torsional damper and water pump as outlined.
2. Remove the two, oil pan-to-front cover attaching screws.
3. Remove the front cover-to-block attaching screws.
4. Pull the cover slightly forward only enough to permit cutting of oil pan front seal.
5. Using a sharp knife or other suitable cutting tool, cut oil pan front seal flush with cylinder block at both sides of cover (fig. 16V).
6. Remove front cover and attaching portion of oil pan front seal. Remove front cover gasket.

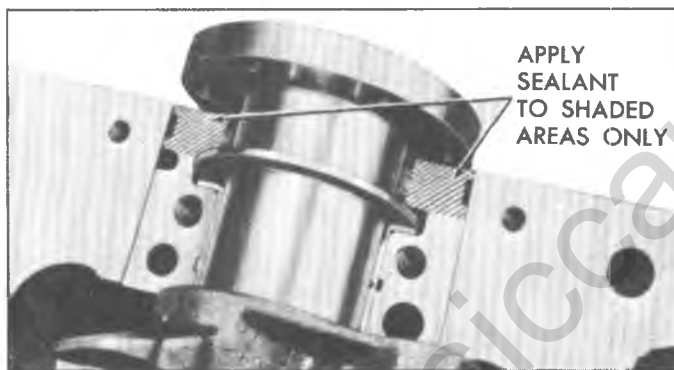

Fig. 13V—Sealing Bearing Cap

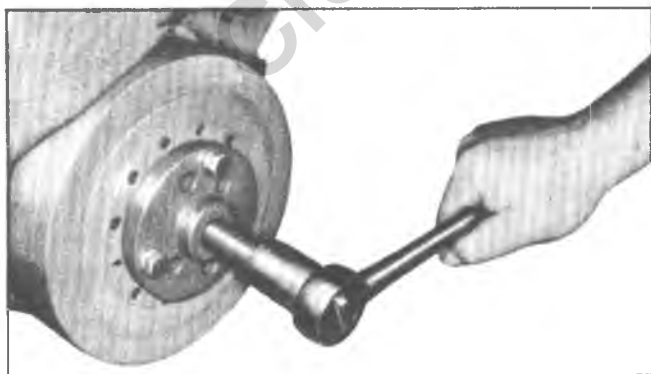

Fig. 14V—Removing Torsional Damper

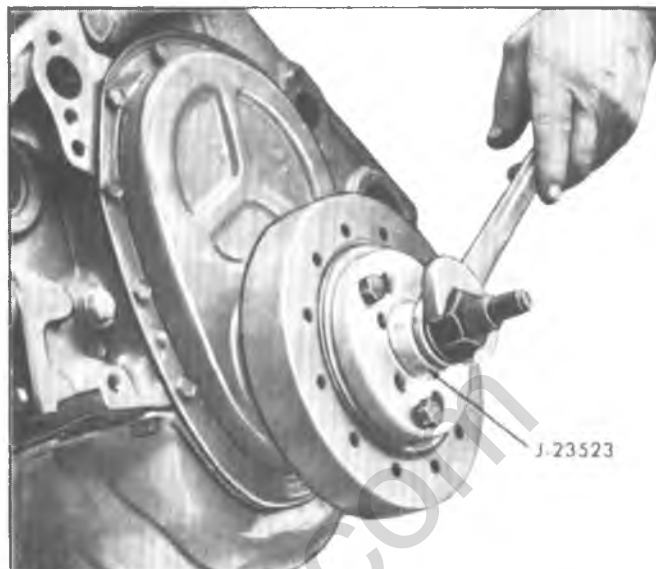

Fig. 15V—Installing Torsional Damper

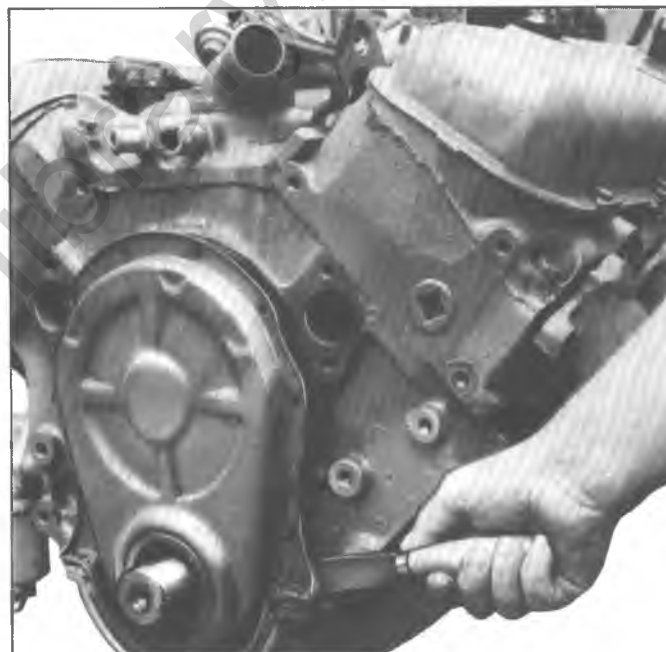

Fig. 16V—Cutting Tabs on Oil Pan Front Seal

### Installation

#### Small V8 Engine

1. Clean gasket surface on block and crankcase front cover.
2. Use a sharp knife or other suitable cutting tool, to remove any excess oil pan gasket material that may be protruding at the oil to engine block junction.
3. Apply a 1/8 inch bead of silicone rubber sealer, part # 1051435 (or equivalent) to the joint formed at the oil pan and cylinder block.
4. Coat the cover gasket with gasket sealer and place in position on cover.
5. Install cover-to-oil pan seal, lightly coat bottom of

seal with engine oil, and position cover over crankshaft end.

6. Loosely install the cover-to-block, upper attaching screws.
7. Tighten screws alternately and evenly while pressing downward on cover so that dowels in block are aligned with corresponding holes in cover.

**NOTE:** Position cover so that dowels enter holes in cover without binding. Do not force cover over dowels so that cover flange or holes are distorted.

8. Install remaining cover screws and torque to specifications.
9. Install torsional damper as outlined.

#### Mark IV V8 Engine

1. Clean gasket surface on block and crankcase front cover.
2. Cut tabs from the new oil pan front seal (fig. 17V), use a sharp instrument to ensure a clean cut.
3. Install seal to front cover, pressing tips into holes provided in cover.
4. Coat the gasket with gasket sealer and place in position on cover.
5. Apply a 1/8 inch bead of silicone rubber sealer, part #1051435 (or equivalent) to the joint formed at the oil pan and cylinder block (fig. 18V).
6. Position crankcase front cover over crankshaft.
7. Press cover downward against oil pan until cover is aligned and installed over dowel pins on block.
8. Install and partially tighten the two, oil pan-to-front cover attaching screws.
9. Install the front cover-to-block attaching screws.
10. Torque all screws to specifications.
11. Install torsional damper and water pump as outlined.

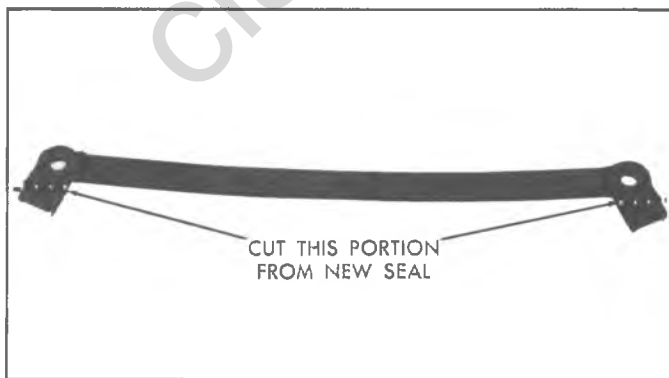

Fig. 17V—Oil Pan Front Seal Modification



Fig. 18V—Applying Front Cover Sealer

#### Oil Seal (Front Cover)

##### Replacement

##### With Cover Removed

1. With cover removed, pry oil seal out of cover from the front with a large screw driver.
2. Install new seal so that open end of the seal is toward the inside of cover and drive it into position with Tool J-23042 on Small V8 engines or Tool J-22102 on Mark IV V8 engines (fig. 19V).

**CAUTION:** Support cover at seal area. (Tool J-971 may be used as support).

##### Without Cover Removed

1. With torsional damper removed, pry seal out of cover from the front with a large screw driver,



Fig. 19V—Installing Oil Seal (Cover Removed)

## 6-58 ENGINE

being careful not to damage the surface on the crankshaft.

2. Install new seal so that open end of seal is toward the inside of cover and drive it into position with Tool J-23042 on Small V8 engines or Tool J-22102 on Mark IV V8 engines (fig. 20V).

## Timing Chain and/or Sprockets

### Replacement

1. Remove torsional damper and crankcase front cover as outlined.
2. Crank engine until marks on camshaft and crankshaft sprockets are in alignment (fig. 21V).
3. Remove camshaft sprocket to camshaft bolts.
4. Remove camshaft sprocket and timing chain together. Sprocket is a light press fit on camshaft. If sprocket does not come off easily, a light blow on the lower edge of the sprocket (with a plastic mallet) should dislodge the sprocket.
5. If crankshaft sprocket is to be replaced on Small V8 engines remove sprocket using Tool J-5825 (fig. 22V). Install new sprocket using bolt and nut from J-23523 (fig. 23V). On Mark IV V8 engines remove sprocket using Tool J-1619 (fig. 24V). Install new sprocket using bolt and nut from Tool J-23523 (fig. 23V).
6. Install timing chain on camshaft sprocket. Hold the sprocket vertically with the chain hanging down and align marks on camshaft and crankshaft sprockets (fig. 25V).

NOTE: Do not attempt to drive sprocket on camshaft as expansion plug at rear of engine can be dislodged.

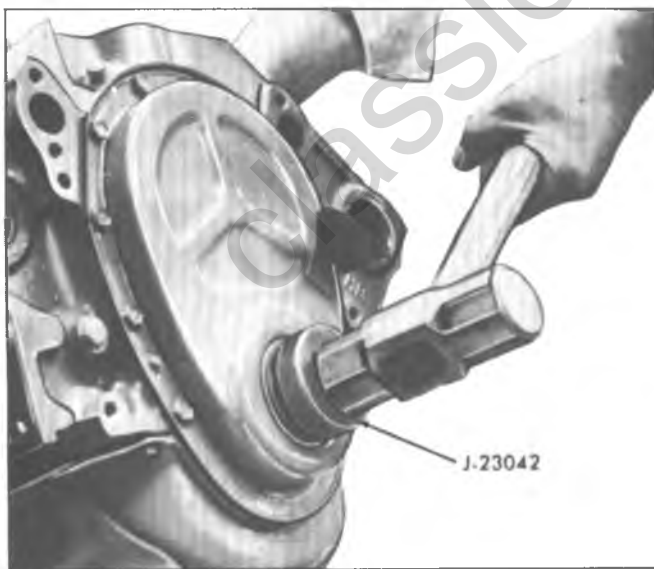

Fig. 20V—Installing Oil Seal (Cover Installed)

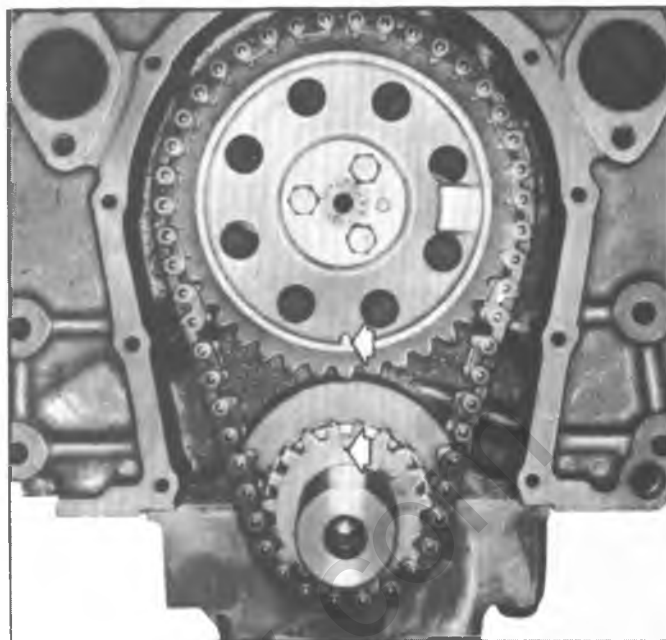

Fig. 21V—Timing Sprocket Alignment Marks

7. Draw camshaft sprocket onto camshaft, using the three mounting bolts. Torque to specifications.
8. Lubricate timing chain with engine oil.
9. Install crankcase front cover and torsional damper as outlined.

## Camshaft

### Measuring Lobe Lift

NOTE: Procedure is similar to that used for checking valve timing. If improper valve operation is indicated, measure the lift of each push rod in consecutive order and record the readings.

1. Remove the valve mechanism as outlined.
2. Position indicator with ball socket adapter (Tool J-8520) on push rod (fig. 26V).

NOTE: Make sure push rod is in the lifter socket.

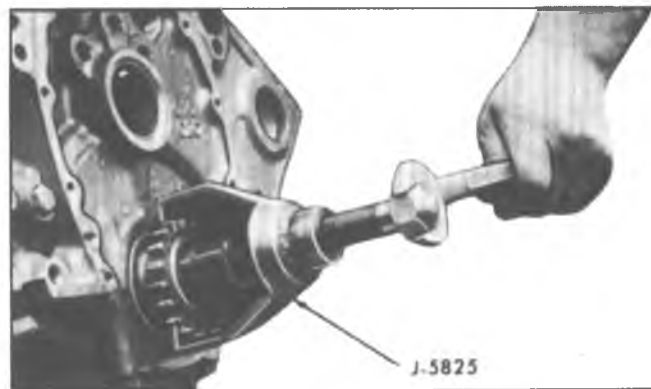

Fig. 22V—Removing Crankshaft Sprocket (Small V8)

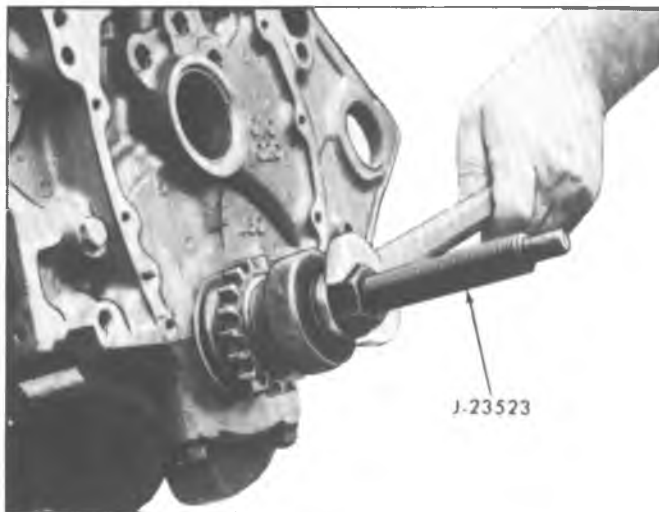

Fig. 23V—Installing Crankshaft Sprocket

3. Rotate the crankshaft slowly in the direction of rotation until the lifter is on the heel of the cam lobe. At this point, the push rod will be in its lowest position.
4. Set dial indicator on zero, then rotate the crankshaft slowly, or attach an auxiliary starter switch and "bump" the engine over, until the push rod is in fully raised position.

**CAUTION:** Whenever the engine is cranked remotely at the starter, with a special jumper cable or other means, the distributor primary lead must be disconnected from the negative post on the coil.

5. Compare the total lift recorded from the dial indicator with specifications.
6. Continue to rotate the engine until the indicator

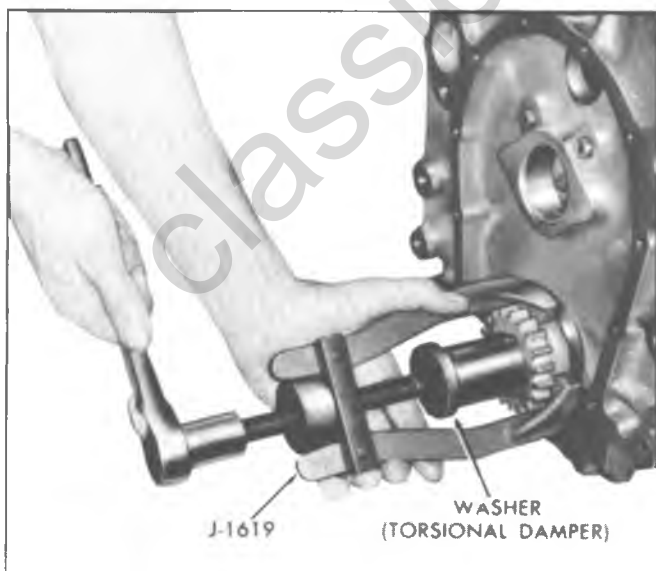

Fig. 24V—Removing Crankshaft Sprocket (Mark IV V8)

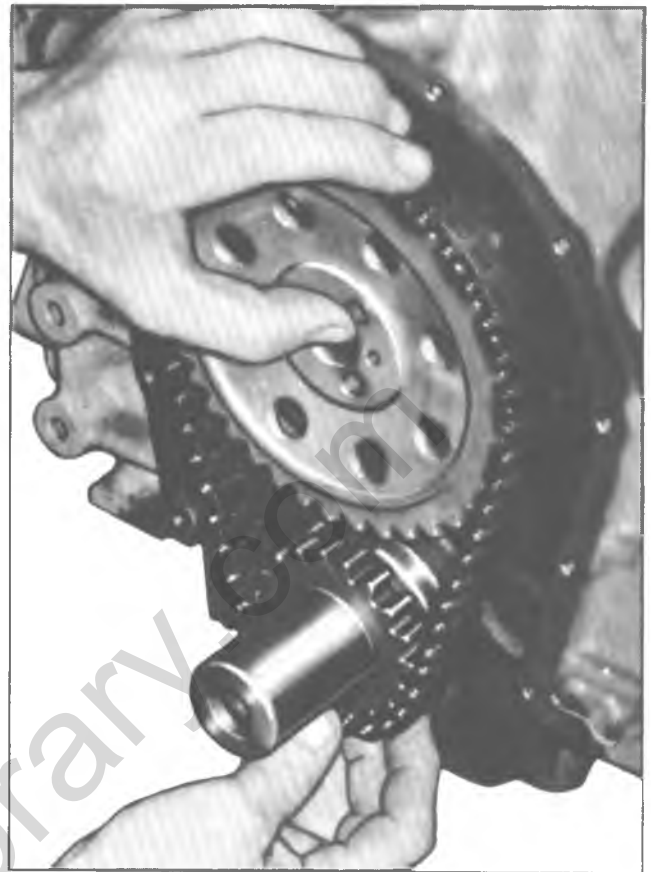

Fig. 25V—Installing Timing Chain

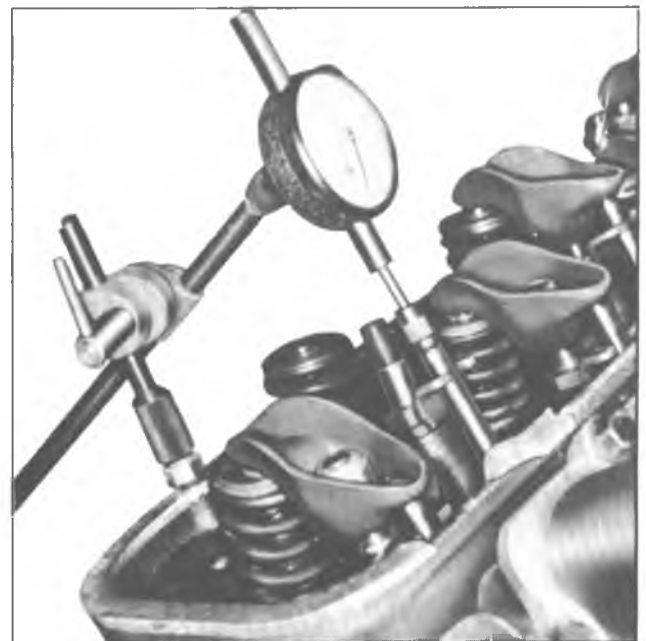

Fig. 26V—Measuring Camshaft Lobe Lift

reads zero. This will be a check on the accuracy of the original indicator reading.

7. If camshaft readings for all lobes are within specifications, remove dial indicator assembly.
8. Install and adjust valve mechanism as outlined.

### Removal

1. Remove valve lifters as outlined.
2. Remove crankcase front cover as outlined.
3. Remove grille (if necessary) as outlined in Section 13.
4. Remove fuel pump push rod as outlined in Section 6M.
5. Complete camshaft removal as follows:  
NOTE: Sprocket is a light fit on camshaft. If sprocket does not come off easily a light blow on the lower edge of the sprocket (with a plastic mallet) should dislodge the sprocket.
6. Install two 5/16" x 18 x 4" bolts in camshaft bolt holes then remove camshaft (fig. 27V).

**CAUTION:** All camshaft journals are the same diameter and care must be used in removing camshaft to avoid damage to bearings.

### Installation

NOTE: Whenever a new camshaft is installed coat camshaft lobes with "Molykote" or its equivalent.

1. Lubricate camshaft journals with engine oil and install camshaft.
2. Install timing chain on camshaft sprocket. Hold the sprocket vertically with the chain hanging down, and align marks on camshaft and crankshaft sprockets. (Refer to fig. 21V and 25V).
3. Align dowel in camshaft with dowel hole in camshaft sprocket then install sprocket on camshaft.

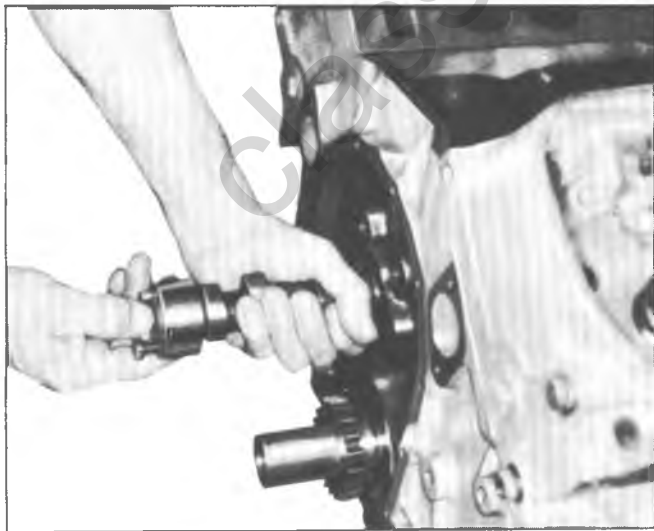

Fig. 27V—Removing Camshaft

4. Draw the camshaft sprocket onto camshaft using the mounting bolts. Torque to specifications.
5. Lubricate timing chain with engine oil.
6. Install fuel pump push rod as outlined in Section 6M.
7. Install grille as outlined in Section 13.
8. Install crankcase front cover as outlined.
9. Install valve lifters as outlined.

### Flywheel

#### Removal

With transmission and/or clutch housing and clutch removed from engine, remove the flywheel.

#### Repair

Only repair recommended at flywheel used with conventional clutch is replacement of starter gear in event gear is worn or otherwise damaged.

Use torch to heat the gear around entire circumference, then drive the gear off flywheel, using care not to damage the flywheel.

Uniformly heat the flywheel gear to temperature which will expand gear to permit installation (temperature must not exceed 400°F.).

As soon as gear has been heated, install on flywheel with chamfered teeth toward engine side of flywheel.

**CAUTION:** NEVER heat starter gear to Red Heat as this will change metal structure.

#### Installation

1. Clean the mating surfaces of flywheel and crankshaft to make certain there are no burrs.
2. Install flywheel on crankshaft and position to align dowel hole of crankshaft flange and flywheel (fig. 28V).  
NOTE: On Automatic Transmission equipped engines, the flywheel must be installed with the flange collar to transmission side (fig. 28V).
3. Coat thread end of bolts with sealer then install bolts and torque to specifications.

### Engine Mounts

Engine mounts (fig. 29V - 34V) are the non-adjustable type and seldom require service. Broken or deteriorated mounts should be replaced immediately, because of the added strain placed on other mounts and drive line components.

#### Checking Engine Mounts

##### Front Mount

Raise the engine to remove weight from the mounts and to place a slight tension in the rubber. Observe both

mounts while raising engine. If an engine mount exhibits:

- Hard rubber surface covered with heat check cracks;
- Rubber separated from a metal plate of the mount; or
- Rubber split through center.

Replace the mount. If there is relative movement between a metal plate of the mount and its attaching points, lower the engine on the mounts and tighten the screws or nuts attaching the mount to the engine, frame, or bracket.

#### Rear Mount

Raise the vehicle on a hoist. Push up and pull down on the transmission tailshaft while observing the transmission mount. If the rubber separates from the metal plate of the mount or if the tailshaft moves up but not down (mount bottomed out) replace the mount. If there is relative movement between a metal plate of the mount and its attaching point, tighten the screws or nuts attaching the mount to the transmission or crossmember.

#### Front Mount Replacement

- Remove distributor cap.
- Remove mount retaining bolt from below frame mounting bracket.
- Raise front of engine and remove mount-to-engine bolts and remove mount.

**CAUTION:** Raise engine only enough for sufficient clearance. Check for interference between rear of engine and cowl panel.

- Replace mount to engine and lower engine into place.

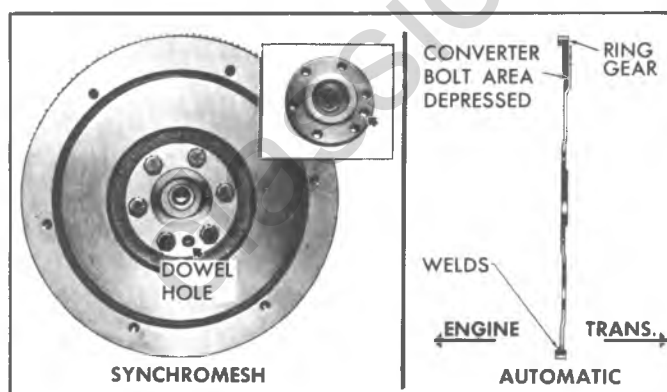

Fig. 28V—Flywheel Installation (Typical)

- Install retaining bolt and torque all bolts to specifications.

#### Rear Mount Replacement

- Support engine weight to relieve rear mounts.
- Remove crossmember-to-mount bolts.
- On P Series with manual transmission and propeller shaft parking brake, remove mount attaching bolts from frame outrigger and clutch housing and remove rear mounting cushions.
- Remove mount-to-transmission bolts, then remove mount.
- On P Series with manual transmission and propeller shaft parking brake, install new mounting cushions and bolts.
- Install new mount on transmission.
- While lowering transmission, align and start crossmember-to-mount bolts.
- Torque bolts to specifications then bend lock tabs to bolt head as applicable.

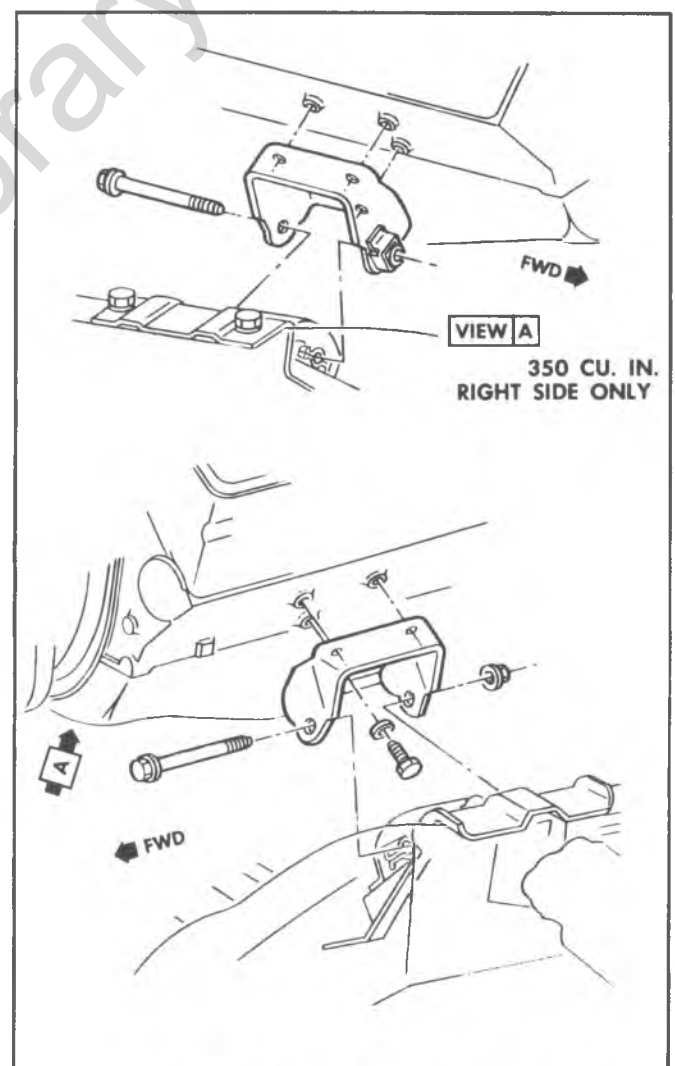
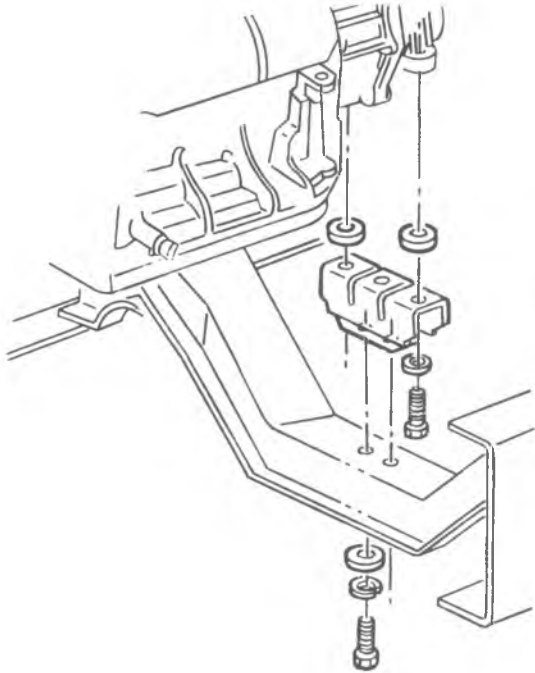
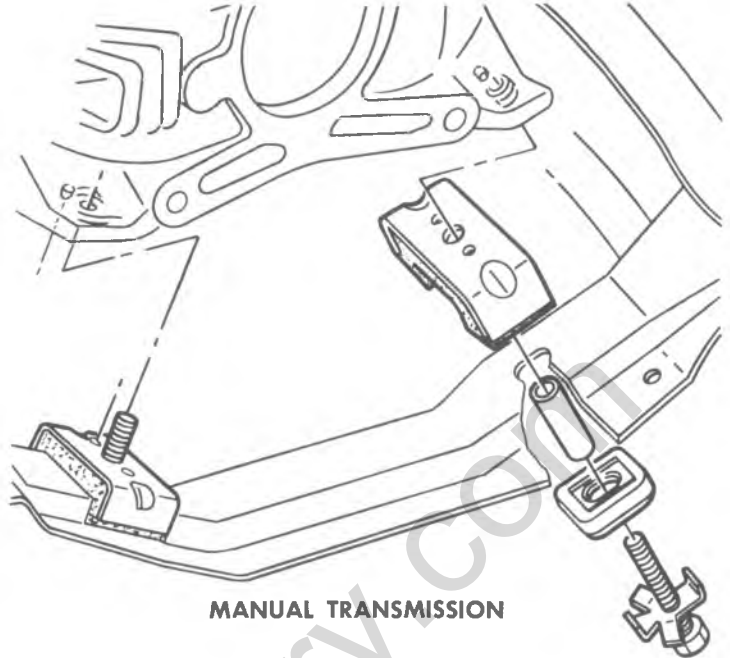

Fig. 29V—P Series Engine Mount Bracket



ALL TURBO HYDRA-MATIC 400  
(EXCEPT MOBILE HOME CHASSIS)

WITHOUT PROPELLER SHAFT PARKING BRAKE



MANUAL TRANSMISSION

WITH PROPELLER SHAFT PARKING BRAKE

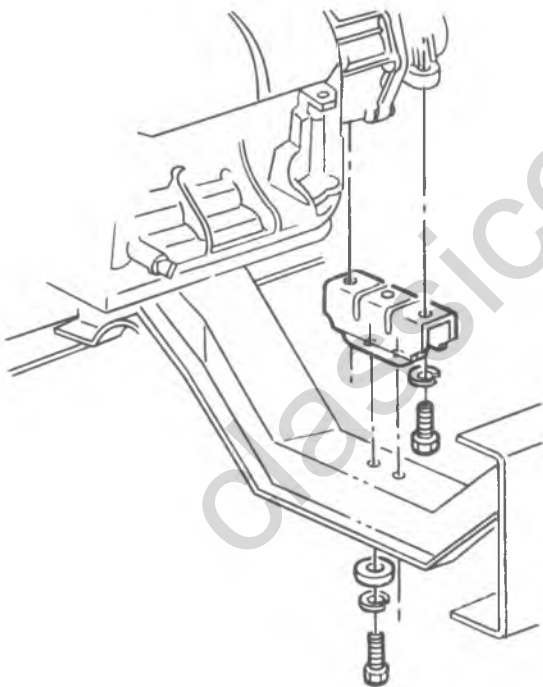

ALL MANUAL TRANSMISSION  
ALL TURBO HYDRA-MATIC 350  
ALL MOBILE HOME CHASSIS

WITHOUT PROPELLER SHAFT PARKING BRAKE

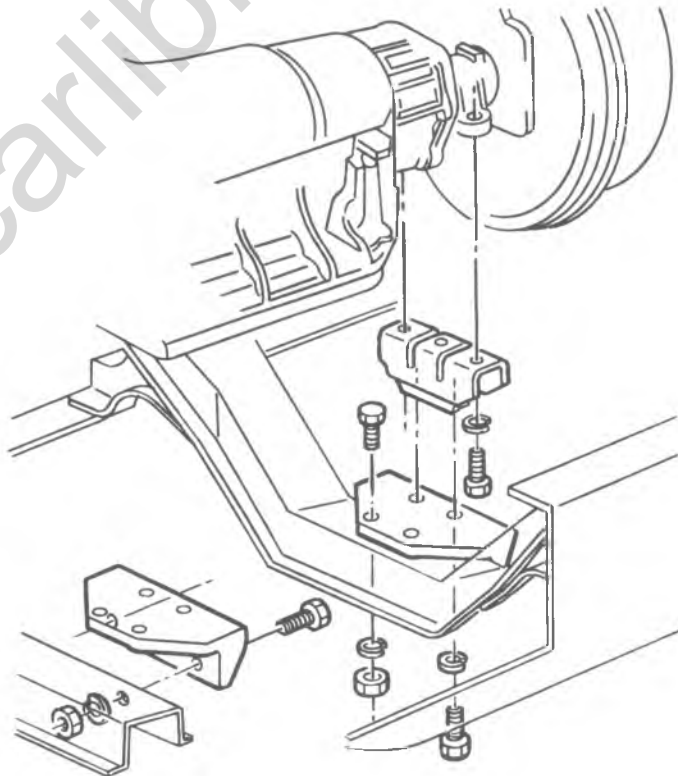

AUTOMATIC TRANSMISSION

WITH PROPELLER SHAFT PARKING BRAKE

Fig. 30V-P Series Engine Rear Mount



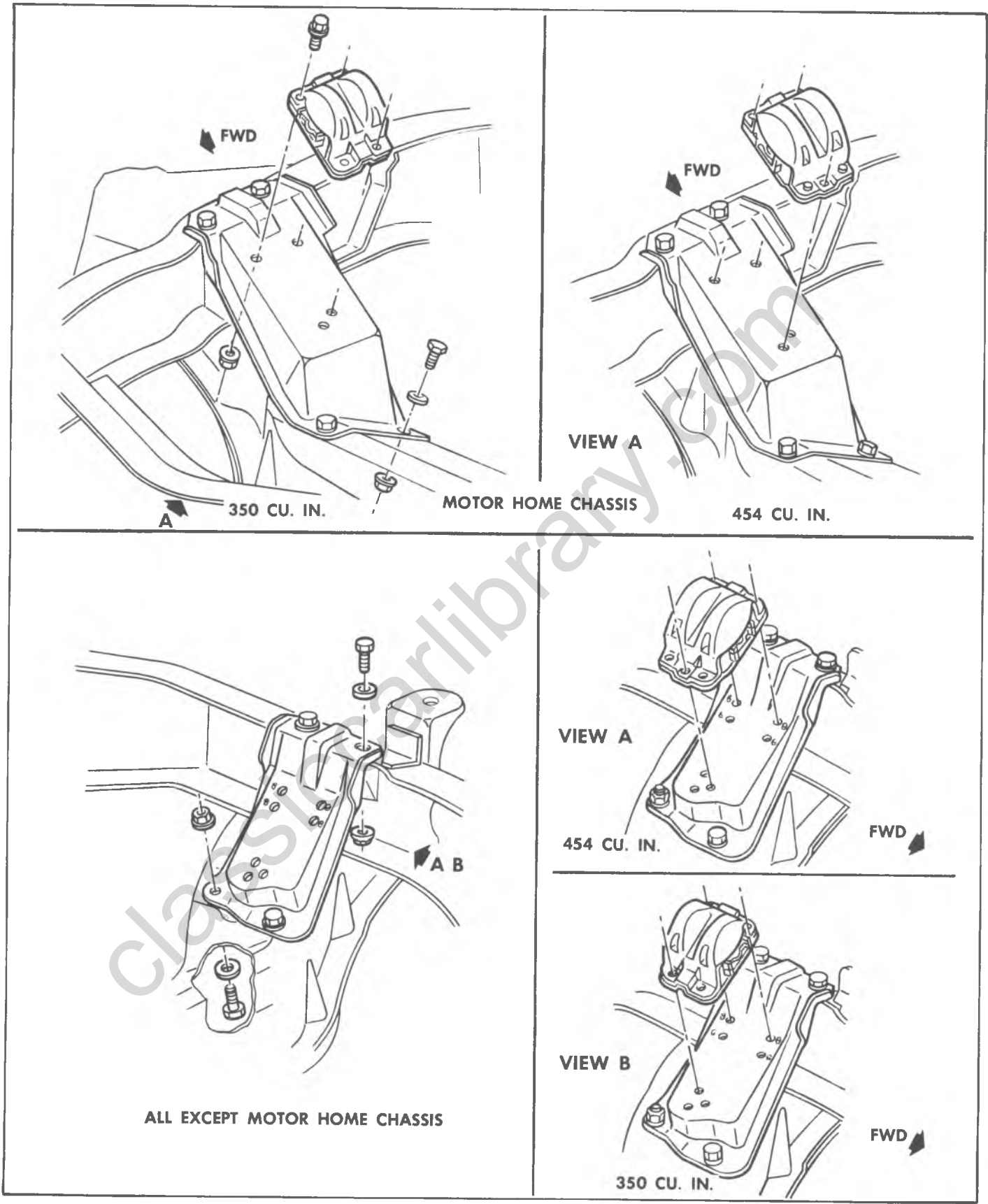

Fig. 31V-P Series Engine Front Mount

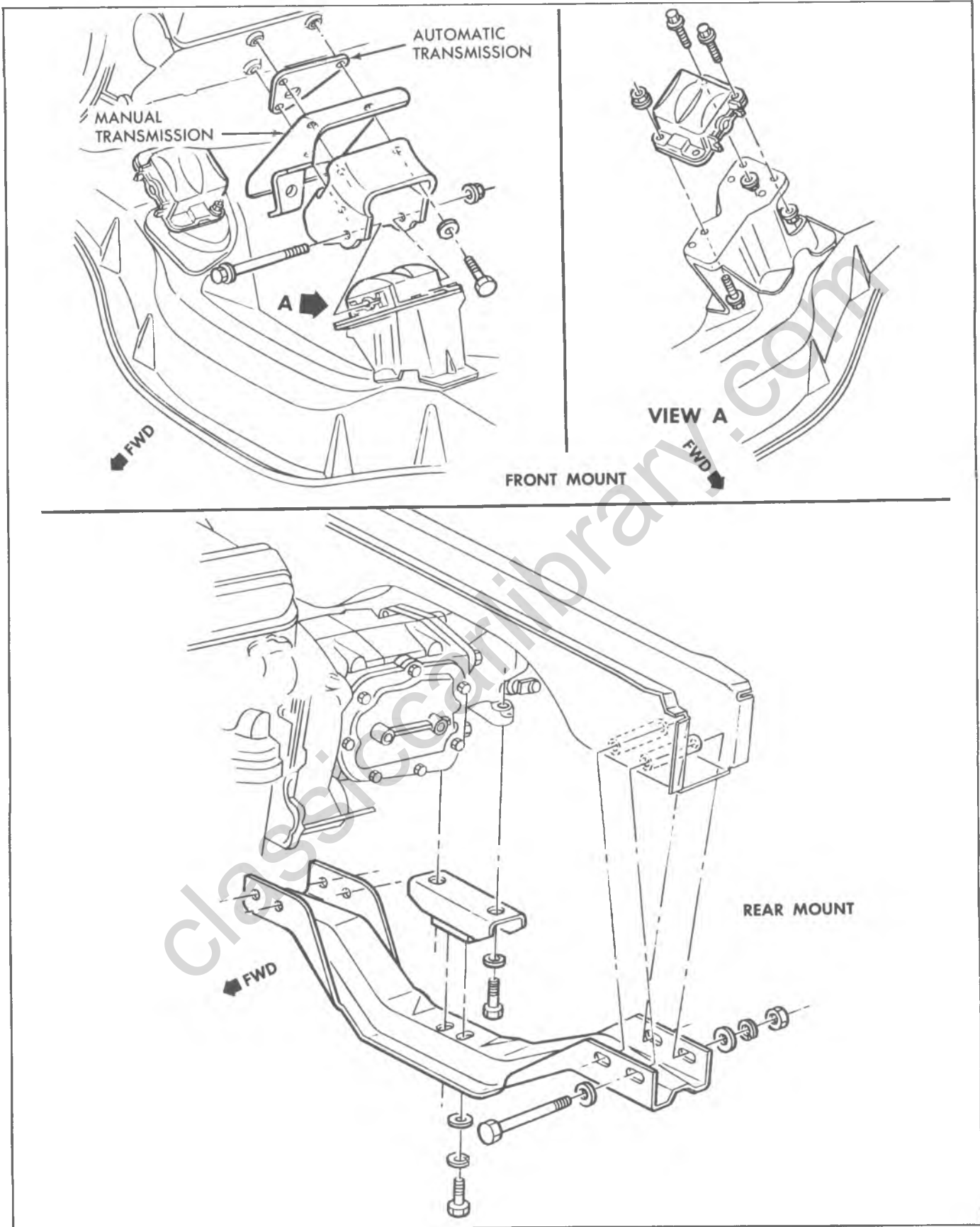

Fig. 32V—G Series Engine Mounts

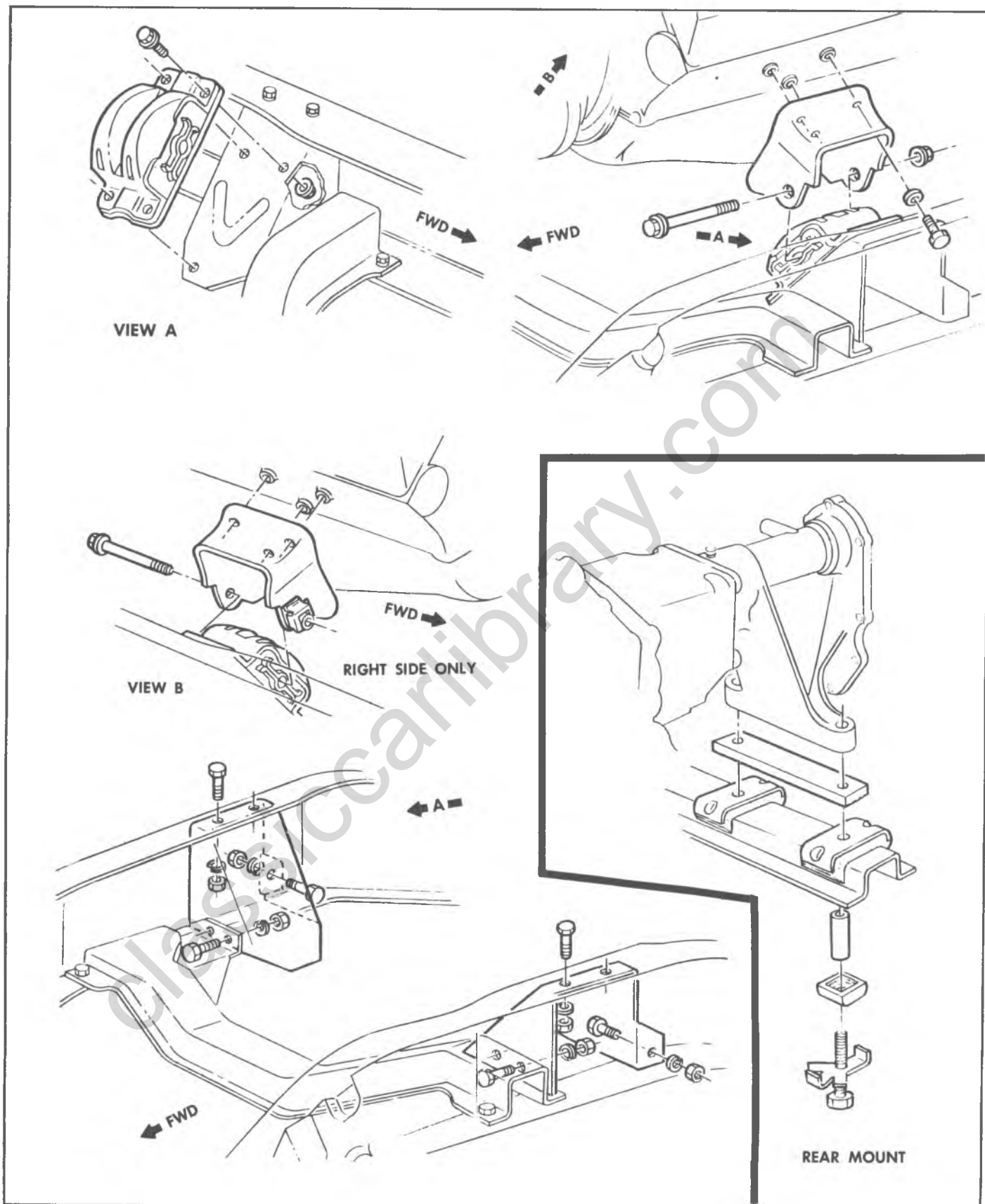

Fig. 33V-K Series Engine Mounts

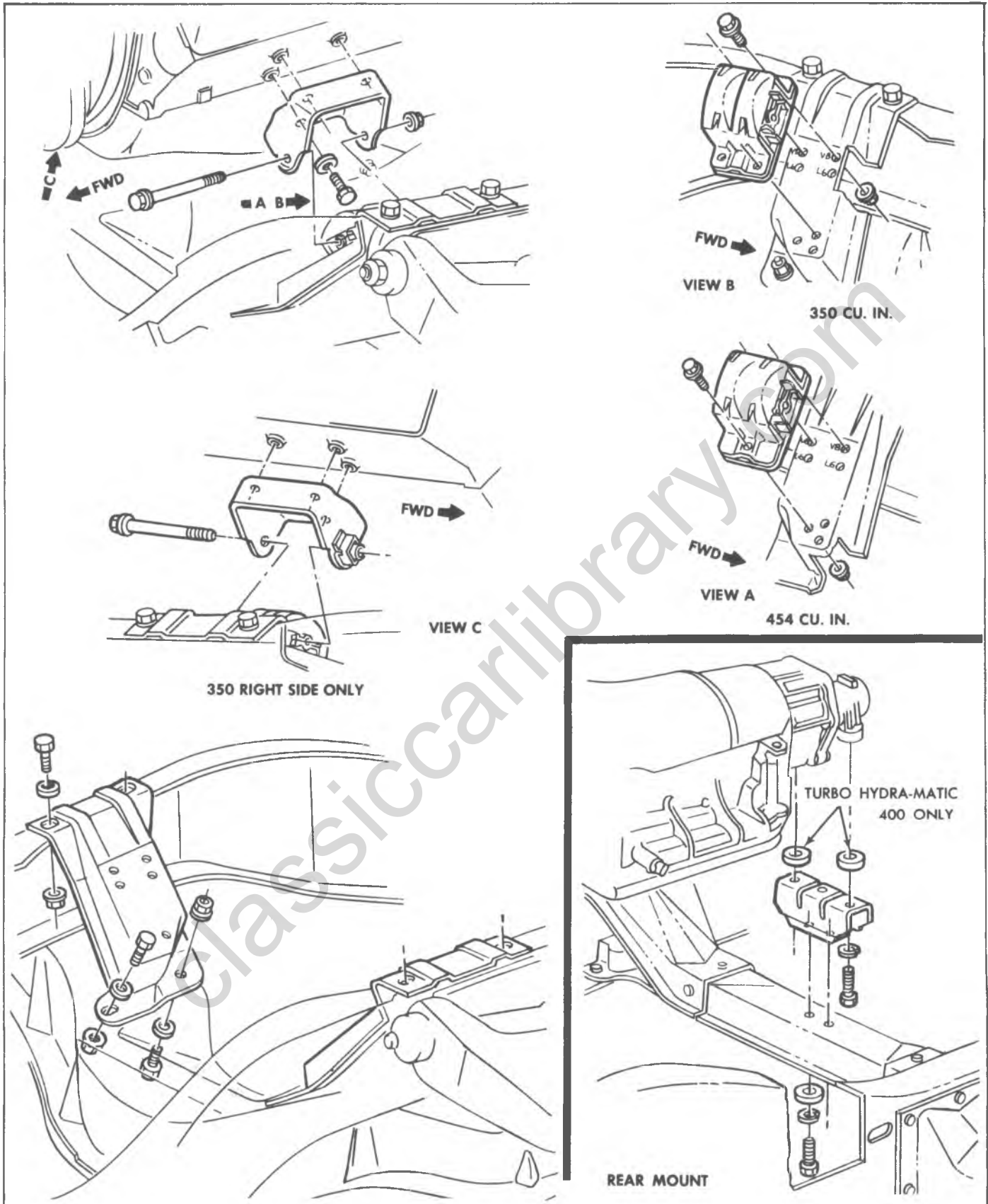

Fig. 34V—C Series Engine Mounts

# DIAGNOSIS

## ENGINE FAILS TO START

### CAUSE

- a. Corroded or loose battery terminal connections and/or weak battery.
- b. Broken or loose ignition wires and/or faulty ignition switch.
- c. Excessive moisture on plugs, caps or ignition system.
- d. Damaged distributor rotor, cracked distributor cap and/or corroded distributor contact points.
- e. Fouled spark plugs and/or improper spark plug gap.
- f. Weak or faulty coil.
- g. Carburetor flooded and/or fuel level in carburetor bowl not correct.
- h. Dirt and water in gas line or carburetor.
- i. Sticking choke.
- j. Faulty fuel pump.
- k. Faulty solenoid or starting motor.
- l. Park or neutral switch inoperative.

## ENGINE LOPES WHILE IDLING

### CAUSE

- a. Air leaks between intake manifold and head.
- b. Blown head gasket.
- c. Worn timing chain or sprockets.
- d. Worn camshaft lobes.
- e. Overheated engine.
- f. Plugged crankcase vent valve.
- g. Faulty fuel pump.
- h. Leaky exhaust gas recirculation valve.

## ENGINE MISSES WHILE IDLING

### CAUSE

- a. Spark plugs damp or gap incorrectly set.
- b. Excessive moisture on ignition wires and cap.
- c. Leaks in ignition wiring.
- d. Ignition wires making poor contact.
- e. Uneven compression.
- f. Burned, pitted or incorrectly set contact points.
- g. Faulty coil or condenser.
- h. Worn distributor cam or cracked distributor cap.

- i. Incorrect carburetor idle adjustment and/or dirty jets or plugged passages in carburetor.
- j. Foreign matter, such as dirt or water, in gas line or carburetor.
- k. Air leak at carburetor mounting gasket.
- l. Choke inoperative.
- m. Faulty spark advance mechanism.
- n. Burned, warped, pitted, or sticking valves.
- o. Incorrect valve lifter clearance.
- p. Low compression.
- q. Leak in exhaust gas recirculation valve.

### ENGINE MISSES AT VARIOUS SPEEDS

#### CAUSE

- a. Dirt and water in gas line or carburetor.
- b. Fouled carburetor jets.
- c. Incorrect ignition timing.
- d. Points dirty, pitted or incorrectly spaced.
- e. Excessive play in distributor shaft.
- f. Insufficient spring tension on points.
- g. Distributor cam lobe worn.
- h. Weak coil or condenser.
- i. Spark plugs dirty or damp and/or gap set too wide.
- j. Insufficient point dwell.
- k. Detonation or pre-ignition.
- l. Excessively worn fuel pump diaphragm.
- m. Weak valve spring.
- n. Worn camshaft lobes.
- o. Engine overheating.
- p. Sub-standard fuel.
- q. Leak in exhaust gas recirculation valve.
- r. Carbon tracked distributor cap or rotor.

### ENGINE STALLS

#### CAUSE

- a. Carburetor idle speed set too low and/or idle mixture too rich or too lean.
- b. Carburetor needle valve and seat inoperative.
- c. Incorrect carburetor float level and/or carburetor flooding.
- d. Dirt or water in gasoline or carburetor.
- e. Choke improperly adjusted or sticking.
- f. Faulty ignition system.
- g. Spark plugs damp or dirty and/or gap incorrectly set.

- h. Faulty coil or condenser.
- i. Distributor points burned, pitted, dirty, or incorrectly set.
- j. Distributor advance inoperative.
- k. Exhaust system restricted.
- l. Leaks in carburetor mounting gasket or intake manifold.
- m. Incorrect valve lifter clearance.
- n. Burned, warped, or sticking valves.
- o. Low compression.
- p. Engine overheating.
- q. Loose, corroded, or leaking wiring connections (bulkhead connector, etc.)
- r. Leak in exhaust gas recirculation valve.

## ENGINE HAS NO POWER

### CAUSE

- a. Weak coil or condenser.
- b. Incorrect ignition timing.
- c. Excessive play in distributor shaft or distributor cam worn.
- d. Insufficient point dwell.
- e. Spark plugs dirty or gap incorrectly set.
- f. Carburetor not functioning properly.
- g. Improper carburetor float level.
- h. Carburetor fuel mixture too rich or too lean.
- i. Foreign matter, such as dirt or water, in gas line or carburetor.
- j. Faulty fuel pump.
- k. Valve spring weak and/or valves sticking when hot.
- l. Valve timing incorrect.
- m. Incorrect valve lifter clearance.
- n. Worn camshaft lobes.
- o. Pistons incorrectly fitted in block.
- p. Blown cylinder head gasket.
- q. Low compression.
- r. Flow control valve inoperative (Power Steering).
- s. Clutch slipping.
- t. Brakes dragging.
- u. Engine overheating.
- v. Transmission regulator valve sticking (Hydra-Matic).
- w. Sub-standard fuel.

**EXTERNAL ENGINE OIL LEAKAGE****CAUSE**

- a. Improperly seated or broken fuel pump gasket.
- b. Improperly seated or broken push rod cover gasket.
- c. Improperly seated or broken oil filter gasket.
- d. Broken or improperly seated oil pan gasket.
- e. Gasket surface of oil pan bent or distorted.
- f. Improperly seated or broken timing chain cover gasket.
- g. Worn timing chain cover oil seal.
- h. Worn or improperly seated rear main bearing oil seal.
- i. Loose oil line plugs.
- j. Engine oil pan drain plug improperly seated.
- k. Camshaft rear bearing drain hole plugged.
- l. Loose rocker arm cover, gasket broken, or cover distorted or bent.

**EXCESSIVE OIL CONSUMPTION DUE TO OIL ENTERING  
COMBUSTION CHAMBER THROUGH HEAD AREA**

**CAUSE**

- a. Intake valve seals damaged, missing or loose.
- b. Worn valve stems or guides.
- c. Plugged drain back holes in head.
- d. Intake manifold side gasket leak at cylinder head inlet port.

**EXCESSIVE OIL CONSUMPTION DUE TO OIL ENTERING  
COMBUSTION CHAMBER BY PASSING PISTON RINGS**

**CAUSE**

- a. Oil level too high.
- b. Excessive main or connecting rod bearing clearance.
- c. Piston ring gaps not staggered.
- d. Incorrect size rings installed.
- e. Piston rings out of round, broken or scored.
- f. Insufficient piston ring tension due to engine overheating.
- g. Ring grooves or oil return slots clogged.
- h. Rings sticking in ring grooves of piston.
- i. Ring grooves worn excessively in piston.
- j. Compression rings installed upside down.
- k. Excessively worn or scored cylinder walls.
- l. Oil too thin.
- m. Mis-match of oil ring expander and rail.



**NO OIL PRESSURE WHILE IDLING****CAUSE**

- a. Faulty oil gauge sending unit.
- b. Oil pump not functioning properly. (Regulator ball stuck in position by foreign material).
- c. Excessive clearance at main and connecting rod bearings.
- d. Loose camshaft bearings.
- e. Leakage at internal oil passages.

**NO OIL PRESSURE WHILE ACCELERATING****CAUSE**

- a. Low oil level in oil pan.
- b. Leakage at internal oil passages.
- c. Oil pump suction screen loose or fallen off.

**BURNED, STICKING OR BROKEN VALVES****CAUSE**

- a. Weak valve springs.
- b. Improper valve lifter clearance.
- c. Improper valve guide clearance and/or worn valve guides.
- d. Out-of-round valve seats or incorrect valve seat width.
- e. Deposits on valve seats and/or gum formation on stems or guides.
- f. Warped valves or faulty valve forgings.
- g. Exhaust back pressure.
- h. Improper spark timing.
- i. Excessive idling.

**NOISY VALVES****CAUSE**

- a. Incorrect valve lifter clearance.
- b. Excessively worn, dirty or faulty valve lifters.
- c. Worn valve guides.
- d. Excessive run-out of valve seat or valve face.
- e. Worn camshaft lobes.
- f. Pulled or loose rocker arm studs.
- g. Bent push rods.
- h. Broken valve spring.

**NOISY PISTONS AND RINGS****CAUSE**

- a. Excessive clearance between piston and bore.

- b. Improper fit of piston pin.
- c. Excessive accumulation of carbon in heads or piston tops.
- d. Connecting rods improperly aligned.
- e. Excessive clearance between rings and grooves.
- f. Rings broken.

### **BROKEN PISTONS AND/OR RINGS**

#### **CAUSE**

- a. Undersize pistons installed.
- b. Wrong type and/or size rings installed.
- c. Cylinder bores tapered or eccentric.
- d. Connecting rods improperly aligned.
- e. Excessively worn ring grooves.
- f. Pins improperly assembled.
- g. Insufficient ring gap clearance.
- h. Engine overheating.
- i. Fuel of too low octane rating.
- j. Too much spark advance.

### **NOISY CONNECTING RODS**

#### **CAUSE**

- a. Connecting rods improperly aligned.
- b. Excessive bearing clearance.
- c. Eccentric or out-of-round crankshaft journals.
- d. Insufficient oil supply.
- e. Low oil pressure.
- f. Connecting rod bolts not tightened correctly.

### **NOISY MAIN BEARINGS**

#### **CAUSE**

- a. Low oil pressure and/or insufficient oil supply.
- b. Excessive bearing clearance.
- c. Excessive crankshaft end play.
- d. Eccentric or out-of-round crankshaft journals.
- e. Sprung crankshaft.
- f. Excessive belt tension.
- g. Loose torsional damper.

### **NOISY VALVE LIFTERS**

- a. Broken valve springs.
- b. Worn or sticking rocker arms.
- c. Worn or bent push rods.
- d. Valve lifters incorrectly fitted to bore size.

- e. Faulty valve lifter plunger or push rod seat.
- f. Plungers excessively worn causing fast leakdown under pressure.
- g. Excessively worn camshaft lobes.
- h. Valve lifter oil feed holes plugged causing internal breakdown.
- i. Faulty valve lifter check ball. (Nicked, flat spot, or out of round).
- j. Rocker arm retaining nut installed upside down.
- k. End of push rod excessively worn or flaked.

## TORQUE SPECIFICATIONS

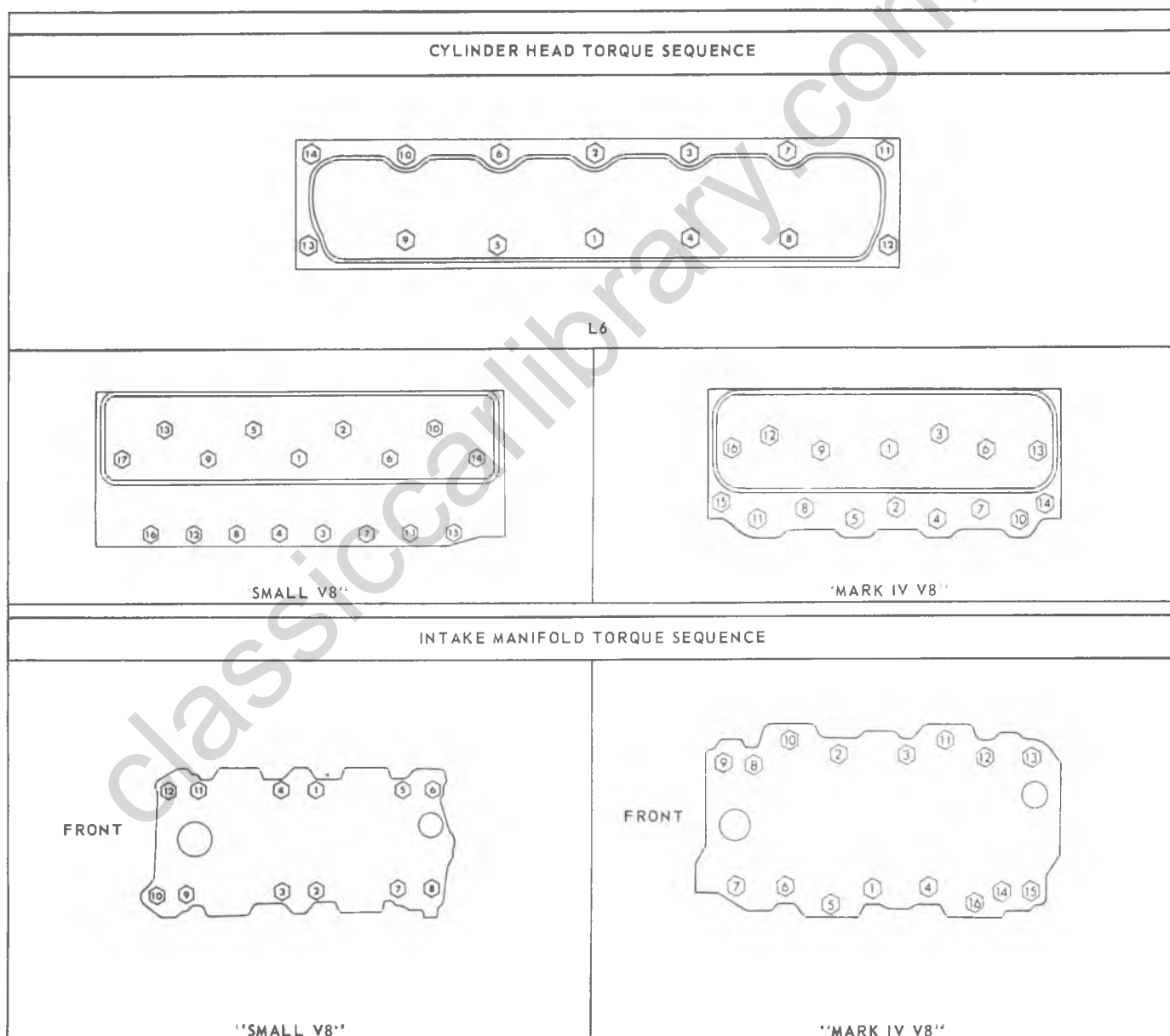

Fig. 1T—Torque Sequence



## SECTION 6K

# ENGINE COOLING

### INDEX

General Description .....	6K-1	Heater Core.....	6K-9
Theory of Operation.....	6K-2	Fan Belt Adjustment.....	6K-9
Maintenance and Adjustments .....	6K-7	Radiator Cap.....	6K-9
Coolant Level.....	6K-7	Thermostat.....	6K-9
Coolant System Checks.....	6K-7	Replacement.....	6K-9
Periodic Maintenance .....	6K-8	Thermostatic Fan Clutch Replacement.....	6K-9
Cleaning.....	6K-8	Water Pump.....	6K-10
Reverse Flushing.....	6K-8	Removal .....	6K-10
Radiator .....	6K-8	Installation .....	6K-11
Cylinder Block and Cylinder Head.....	6K-8	Diagnosis.....	6K-11

## GENERAL DESCRIPTION

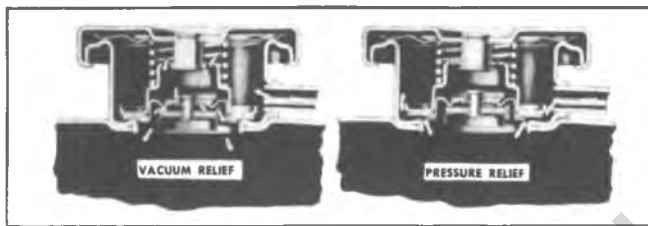

Fig. 1—Radiator Pressure Cap

All trucks have pressure type engine cooling systems with thermostatic control of coolant circulation. The cooling system is sealed by a pressure type radiator filler cap.

The pressure type radiator filler cap (fig. 1) is designed to operate the cooling system at higher than atmospheric pressure. The higher pressure raises the boiling point of the coolant which increases the efficiency of the radiator.

The radiator filler cap contains a pressure relief valve and a vacuum relief valve. The pressure relief valve is held against its seat by a spring which when compressed, allows excessive pressure to be relieved out the radiator overflow.

The vacuum valve is also held against its seat by a spring which when compressed, opens the valve relieving the vacuum created when the system cools.

The cooling system's water pump is of the centrifugal vane impeller type (figs. 2 and 3). The bearings are permanently lubricated during manufacture and are sealed to prevent the loss of lubricant or the entry of dirt and water. The pump requires no care other than to make certain the air vent at the top of the housing and

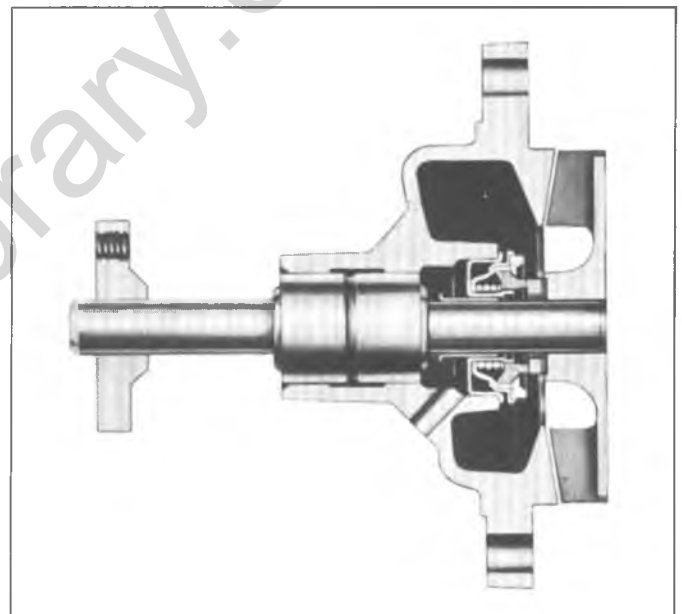

Fig. 2—Water Pump—Typical L-6

the drain holes in the bottom do not become plugged with dirt or grease.

Water pump components are not serviced separately; therefore, in the event of water pump failure, it will be necessary to replace the complete assembly — removal and installation procedures are covered in this section. For radiator service refer to Section 13 of this manual. Radiator fan shroud replacement is covered in Section 11 of this manual.

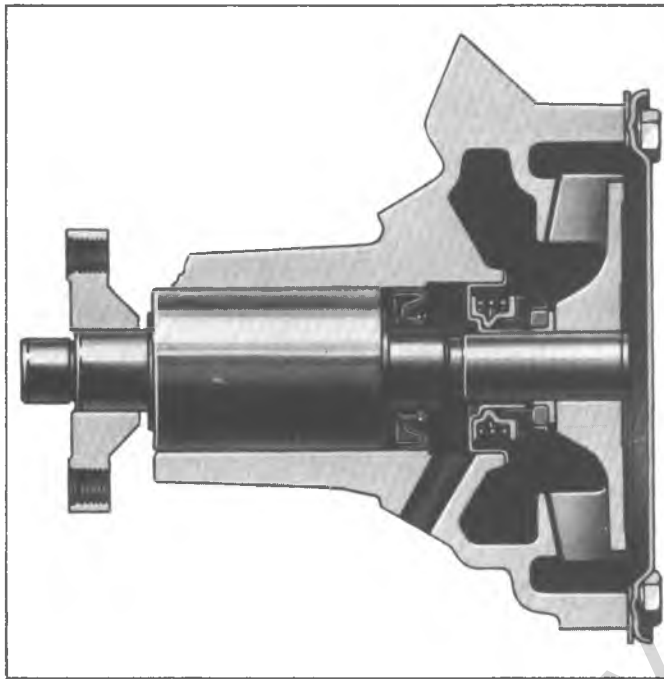

Fig. 3—Water Pump—Typical V-8

## THEORY OF OPERATION

The engine cooling system is designed to maintain the engine at its most efficient operating temperature at all engine speeds and all driving conditions. During combustion of the air-fuel mixture, combustion gas temperatures may be as high as 4500 degrees. The cylinder walls, cylinder heads and pistons absorb some but not all of the heat. They, in turn, must be provided with some means of cooling to prevent permanent damage. Temperatures higher than the limit imposed by the oil properties will destroy the lubricating characteristics of the oil and lead to subsequent engine failure. It is desirable to operate the engine at a temperature as close as possible to the limit imposed by the oil properties. Removing too much heat would lower the thermal efficiency; therefore, the cooling system functions to remove approximately 35 percent of the heat produced during combustion.

### COOLING SYSTEM CIRCULATION

#### Six-Cylinder Engine

The water pump discharges coolant into the water jacket chamber between the front face of the block and the number one cylinder (Fig. 4). Coolant then flows through the block, toward the rear, passing through two large cast openings into the cylinder head, to cool the valve seats, and forward to the water outlet at the front of the head. Some coolant is directed through a small hole in the cylinder head gasket to an area around each spark plug. During engine warm-up, when the thermostat is closed, coolant is redirected to the water pump through a

coolant by-pass in the cylinder head and block. Coolant circulation, after normal operating temperatures are reached (thermostat open), flows through the coolant outlet and the pellet-type thermostat to the radiator.

#### Eight-Cylinder Engine

The water pump discharges coolant to each bank of cylinders. The coolant flow is from the front of each bank around each cylinder and toward the rear of the block. Large passages connecting the block to cylinder head directs coolant over and around the alternately spaced inlet and exhaust ports, as well as around the exposed exhaust valve guide inserts. Smaller circular holes permit metered amounts of coolant to pass from the cylinder block to cored passages surrounding the spark plugs.

On "Small V8" engines during warm up (thermostat closed), coolant is redirected, through a small passage located in the front of the right cylinder head and block to a mating hole in the extreme lower portion of the water pump runner.

On "Mark IV" engines during warm up (thermostat closed), coolant is redirected to the water pump by way of a recirculating passage in the intake manifold which is connected externally to the pump body.

Coolant circulation after normal operating temperatures are obtained (thermostat open), is directed from the intake manifold through the coolant outlet and thermostat to the radiator.

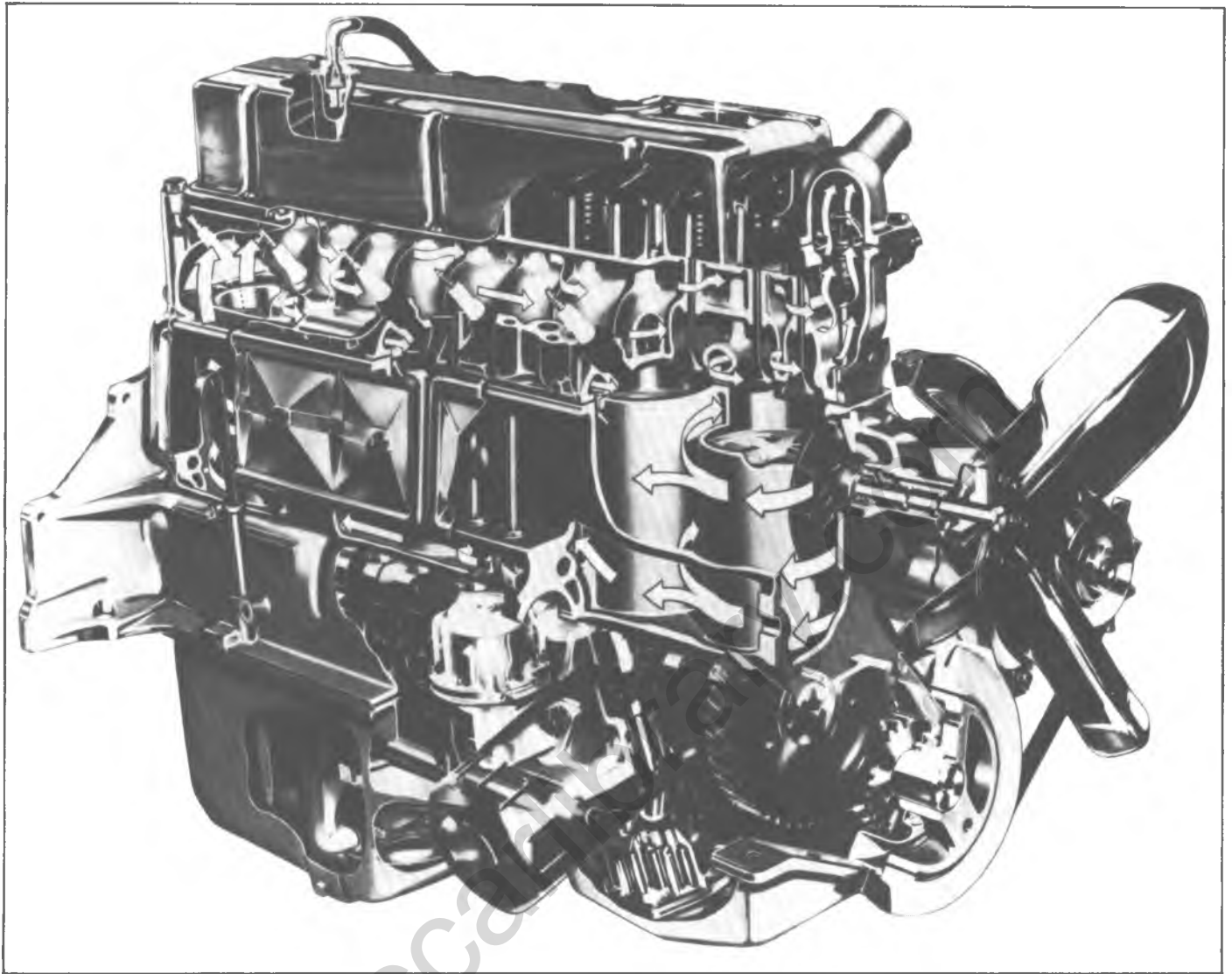

Fig. 4—Engine Coolant Circulation (Six-Cylinder)

## COMPONENTS

### Water Pump

The cooling system water pump is of the centrifugal vane impeller type. The impeller turns on a steel shaft that rotates on a double row of permanently lubricated ball bearings, which are sealed during manufacture to prevent loss of lubricant and to prevent entry of dirt and water.

The pump inlet is connected to the bottom of the radiator by means of a rubber hose. Pump outlet is separate from the pump and is located in the thermostat housing which is connected to the top of the radiator by a rubber hose.

### Radiator

Radiators are designed to hold a large volume of coolant so that the coolant is also exposed to a large volume of air. The object being to transfer heat produced during

combustion to the coolant and then to transfer heat in the coolant to air flowing passed the radiator.

Radiators are of the cross-flow type (Fig. 5). The water flows horizontally from the input (left) tank through the individual cores to the output (right) tank.

Radiators used on vehicles equipped with automatic transmission may, in some instances, have oil coolers into the right (output) tank. Inlet and outlet fittings for transmission fluid circulation are positioned vertically on the tank.

### Radiator Cap

The pressure type radiator filler cap is designed to operate the cooling system at higher than atmospheric pressure. The higher pressure raises the boiling point of the coolant, which increases the efficiency of the radiator.

The radiator filler cap contains a pressure relief valve and a vacuum relief valve. The pressure relief valve is

## 6K-4 ENGINE COOLING

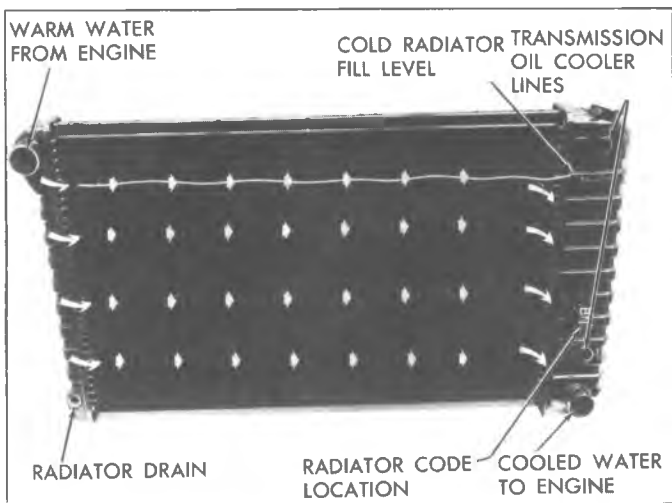

Fig. 5—Typical Cross-Flow Radiator

held against its seat by a spring, which, when compressed, allows excessive pressure to be relieved out the radiator overflow. The vacuum valve is also held against its seat by a spring which, when compressed, opens the valve to relieve the vacuum created when the system cools.

### Fan

The cooling fan is located on the end of the water pump shaft and is driven by the same belt that drives the pump. In some instances a fan shroud surrounds the fan. This shroud increases the cooling system efficiency by ensuring that all air pulled in by the fan passes through the radiator. Basically there are two types of fans: a fixed drive fan (which rotates at water pump - engine rpm - speed) and the automatic fan clutch.

Automatic fan clutches, Figure 6, are hydraulic devices used to vary the speed in relation to the engine temperature. Automatic fan clutches are used with many engines, especially those equipped with factory installed air conditioning units. Automatic fan clutches permit the use of a high delivery fan to insure adequate cooling at reduced engine speeds while eliminating overcooling, excessive noise, and power loss at high speeds.

The automatic fan clutch has two modes of operation, the engaged mode and the disengaged mode. The disengaged mode (engine cold or high speed driving) occurs when the silicone fluid is contained in the reservoir area of the fan clutch. As the temperature of the engine rises so does the temperature of the bimetallic coil. This bimetallic coil is connected to the arm shaft in such a way that as the temperature rises the shaft moves the arm exposing an opening in the pump plate. This opening allows the silicone fluid to flow from the reservoir into the working chamber of the automatic fan clutch.

The silicone fluid is kept circulating through the fan clutch by wipers located on the pump plate. A hole is located in front of each wiper, Figure 7. The speed differential between the clutch plate and the pump plate

develops high pressure areas in front of the wipers, thus the fluid is forced back into the reservoir. But as the temperature rises the arm uncovers more of the large opening and allows more of the silicone fluid to re-enter the working chamber.

The automatic fan clutch becomes fully engaged when the silicone fluid, circulating between the working chamber and the reservoir, reaches a sufficient level in the working chamber to completely fill the grooves in the clutch body and clutch plate.

The resistance of the silicone fluid to the shearing action caused by the speed differential between the grooves transmits torque to the clutch body. The reverse situation occurs when the temperature drops. The arm slowly closes off the return hole thus blocking the fluid flow from the reservoir into the working chamber.

The continuous action of the wipers removes the silicone fluid from the grooves in the working chamber and reduces the shearing action. Thus, less torque is transmitted to the clutch body and the speed of the fan decreases.

The temperature at which the automatic fan clutch engages and disengages is controlled by the setting of the bimetallic coil. This setting is tailored to satisfy the cooling requirements of each model.

## FAN CLUTCH DIAGNOSTIC PROCEDURE

### 1. NOISE

Fan noise is sometimes evident under the following normal conditions: a. when clutch is engaged for maximum cooling, and b. during first few minutes after start-up until the clutch can re-distribute the silicone fluid back to its normal disengaged operating condition after overnight settling.

However, fan noise or an excessive roar will generally occur continuously under all high engine speed conditions (2500 r.p.m. and up) if the clutch assembly is locked up due to an internal failure. If the fan cannot be rotated by hand or there is a rough grating feel as the fan is turned, the clutch should be replaced.

### 2. LOOSENESS

Under various temperature conditions, there is a visible lateral movement that can be observed at the tip of the fan blade. This is a normal condition due to the type of bearing used. Approximately 1/4" maximum lateral movement measured at the fan tip is allowable. This is not cause for replacement.

### 3. SILICONE FLUID LEAK

The operation of the unit is generally not affected by small fluid leaks which may occur in the area around the bearing assembly. However, if the degree of leakage appears excessive, proceed to item 4.



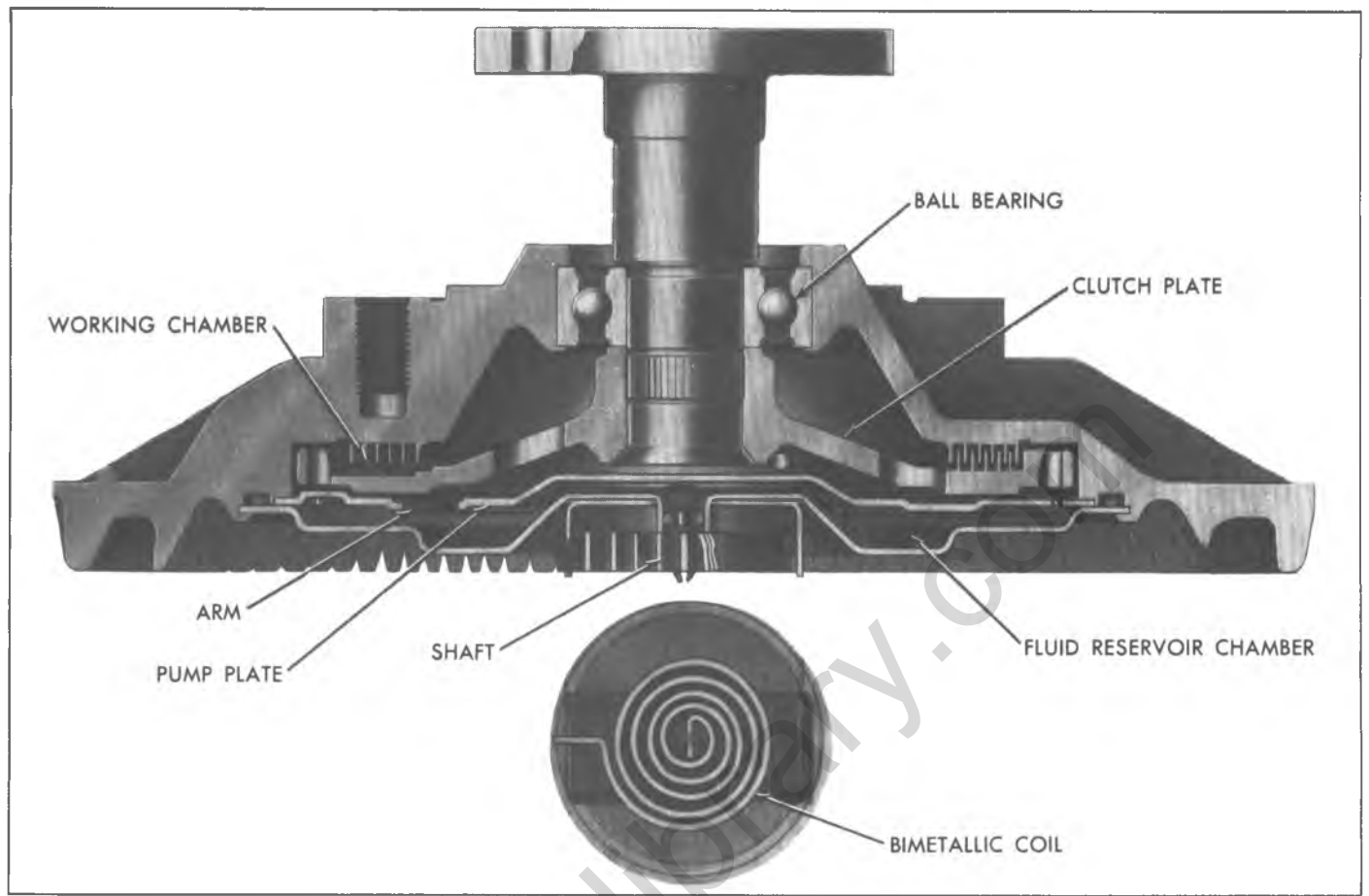

Fig. 6—Automatic Fan Clutch

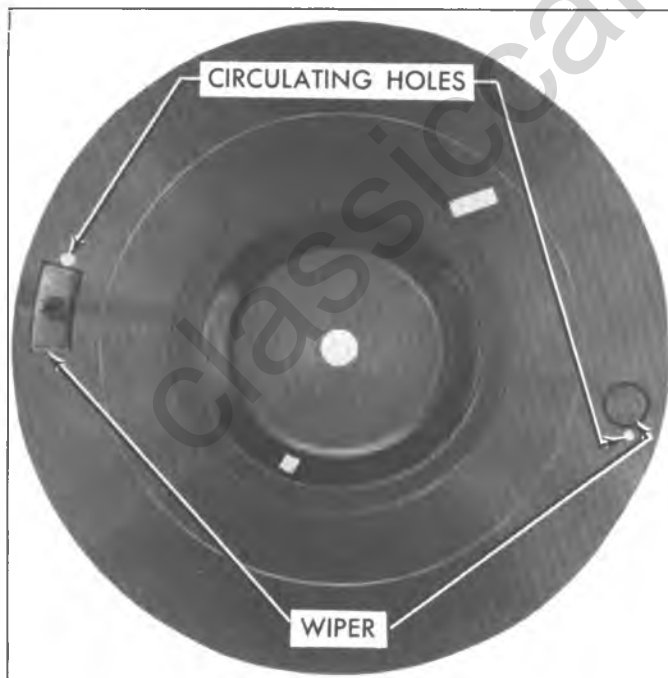

Fig. 7—Fan Clutch Pump Plate

#### 4. ENGINE OVERHEATING

- A. Start with a cool engine to ensure complete fan clutch disengagement. Refer to Item b, paragraph 1.
- B. If the fan and clutch assembly free-wheels with no drag (revolves over 5 times when spun by hand), the clutch should be replaced. If clutch performs properly with a slight drag go to step C.

NOTE: Testing a fan clutch by holding the small hub with one hand and rotating the aluminum housing in a clockwise/counter-clockwise motion will cause the clutch to free-wheel, which is a normal condition when operated in this manner. This should not be considered a test by which replacement is determined.

- C. Use dial type thermometer, J6742-01, or similar type.

NOTE: J6742-01 reads to 180 degrees F, therefore, allow approximately 3/16" pointer movement for each 10 degrees over 180 degrees.

**CAUTION:** Check for adequate clearance

## 6K-6 ENGINE COOLING

between fan blades and thermometer sensor before starting engine.

Position thermometer so that the thermometer sensor is centered in the space between the fan blades and radiator. This can be achieved by inserting the sensor through one of the existing holes in the fan shroud or fan guard, or by placing between the radiator and the shroud. On some models, it may be necessary to drill a 3/16" hole in the fan shroud to insert J6742-01.

- D. Cover radiator grille sufficiently to induce a high engine temperature. Start engine and turn on air conditioning if equipped. Maintain a position in front of the vehicle to observe the thermometer reading. With a rod, broom handle, or etc., push on the accelerator linkage to maintain approximately 3000 r.p.m. Use tachometer if available.
- E. Observe thermometer reading when clutch engages. It will take approximately 5 to 10 minutes for the temperature to become high enough to allow engagement of the fan clutch. This will be indicated by an increase or roar in fan air noise and by a drop in the thermometer reading of approximately 5-15 degrees F. If the clutch did not engage between 165-190 degrees F., the unit should be replaced.

NOTE: Be sure fan clutch was disengaged at beginning of test.

**CAUTION:** Do not continue test past a thermometer reading of 190 degrees F to prevent engine overheating.

If no sharp increase in fan noise or temperature drop was observed and the fan noise level was constantly high from start of test to 190 degrees F, the unit should be replaced.

- F. As soon as the clutch engages, remove the radiator grille cover and turn off the air conditioning to assist in engine cooling. The engine should be run at approximately 1500 r.p.m.
- G. After several minutes the fan clutch should disengage, as indicated by a reduction in fan speed and roar.

### Thermostat

A pellet-type thermostat is used in the coolant outlet passage to control the flow of engine coolant, to provide fast engine warm-up and to regulate coolant temperatures. A wax pellet or powder element in the thermostat expands when heated and contracts when cooled (Fig. 8). The pellet is connected through a piston to a valve. When the pellet is heated, pressure is exerted against a rubber diaphragm which forces the valve to open. As the pellet is cooled, the contraction allows a spring to close the valve. Thus, the valve remains closed while the coolant is cold, preventing circulation of coolant through the radiator, but allowing the coolant to circulate throughout the engine to warm it quickly and evenly.

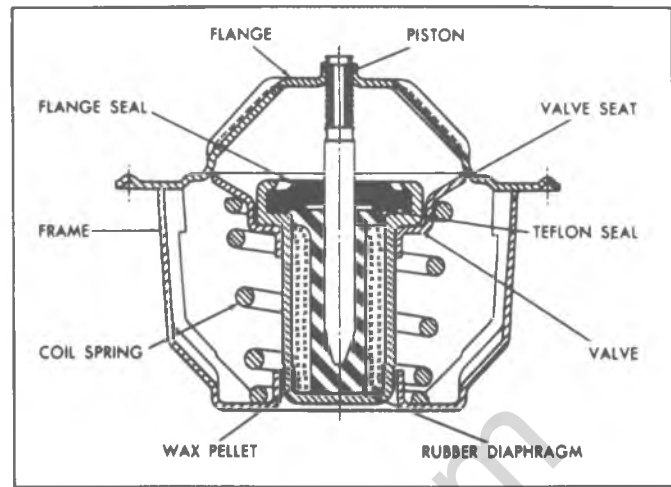

Fig. 8—Sectional View of Thermostat

As the engine becomes warm, the pellet expands and the thermostat valve opens, permitting the coolant to flow through the radiator where heat is passed through the radiator walls. This opening and closing of the thermostat valve permits enough coolant to enter the radiator to keep the engine within operating temperature limits.

### Coolant

Regardless of whether freezing temperatures are or are not expected, cooling system protection should be maintained at least to -20°F. to provide adequate corrosion protection and proper temperature indicating light operation. With glycol content less than require-

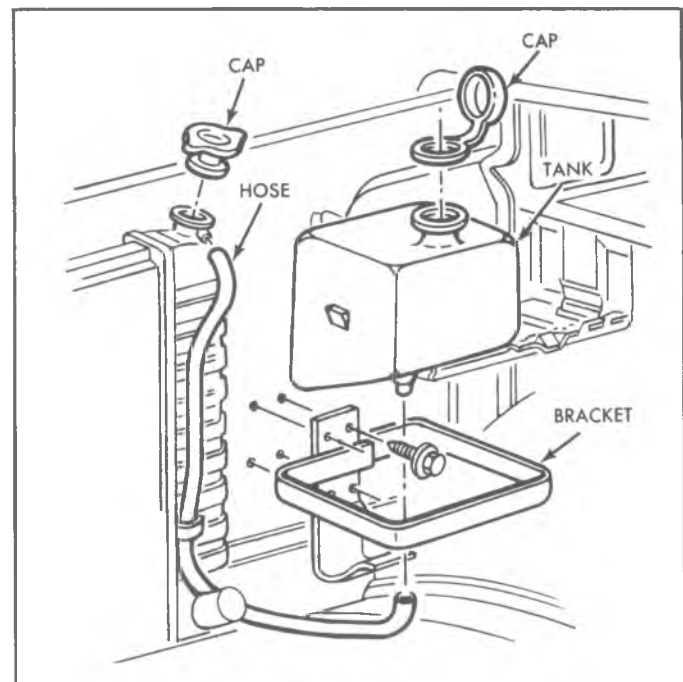

Fig. 9—Coolant Recovery System (Typical)

ment for -20°F. protection, coolant boiling point is less than the temperature indicating light setting. When adding solution due to loss of coolant for any reason or in areas where temperatures lower than -20°F. may occur, a sufficient amount of an ethylene glycol base coolant that meets GM Specification 1899-M should be used.

Every two years the cooling system should be serviced by flushing with plain water, than completely refilled with a fresh solution of water and a high-quality, inhibited (permanent-type) glycol base coolant meeting GM Specification 1899-M and providing freezing protection at least to -20°F. At this time, also add GM Cooling

System Inhibitor and Sealer or equivalent. In addition, Cooling System Inhibitor and Sealer should be added every fall thereafter. GM Cooling System Inhibitor retards the formation of rust or scale and is compatible with aluminum components.

NOTE: Alcohol or methanol base coolants or plain water are not recommended for engine coolant at any time.

### Coolant Recovery System

The coolant recovery system supplements the standard cooling system in that additional coolant is available from a translucent plastic reservoir (Fig. 9).

## MAINTENANCE AND ADJUSTMENTS

### Engine Cooling System

The recovery type cooling system is standard on all 10-30 series trucks and is designed to maintain the engine at proper operating temperatures. The recovery tank collects coolant that expands with rising temperature that would otherwise overflow from the system. When the system temperature drops, the coolant is drawn from the recovery tank back into the radiator by the suction created by coolant contraction. The cooling system has been filled at the factory with a high-quality, inhibited, year-around coolant that meets the standards of General Motors Specification 1899-M. This coolant solution provides freezing protection to -20°F (-35°F. in Canada), and it has been formulated to be used for two full calendar years or 24,000 miles, whichever first occurs, of normal operation without replacement.

### Cooling System Care

Check the coolant level in the translucent coolant recovery tank and in the radiator at least as frequently as engine oil changes.

NOTE: Do not remove radiator cap when coolant is hot and under pressure.

Level should be at the "full cold" mark on the recovery tank and at the bottom of the radiator filler neck when the system is cold. If the recovery tank is empty or coolant is below the "full cold" mark the radiator level should be checked and coolant added to the radiator and recovery tank as needed. Use a 50/50 mixture of high quality ethylene glycol antifreeze and water for coolant additions. If regular additions are required see your dealer for a cooling system check.

NOTE: If recommended quality antifreeze is used, supplemental inhibitors or additives claiming to provide increased capability are not necessary. They may be detrimental to the efficient operation of the system, and represent an unnecessary operating expense.

All truck cooling systems are pressurized with a 15 lb. pressure cap which permits safe engine operation at cooling temperatures of up to 256°F. with a 33% glycol solution.

When the radiator cap is removed or loosened, the system pressure drops to atmospheric, and the heat which had caused water temperature to be higher than 212°F, will be dissipated by conversion of water to steam. Inasmuch as the steam may form in the engine water passages, it will blow coolant out of the radiator upper hose and top tank, necessitating coolant replacement. Engine operating temperatures higher than the normal boiling point of water are in no way objectionable so long as the coolant level is satisfactory when the engine is cool.

### Coolant System Checks

1. Test for restriction in the radiator, by warming the engine up and then turning the engine off and feeling the radiator. The radiator should be hot along the left side and warm along the right side with an even temperature rise from right to left. Cold spots in the radiator indicate clogged sections.
2. Water pump operation may be checked by running the engine while squeezing the radiator upper hose. A pressure surge should be felt. Check for a plugged vent-hole in pump.

NOTE: A defective head gasket may allow exhaust gases to leak into the cooling system. This is particularly damaging to the cooling system as the gases combine with the water to form acids which are harmful to both the radiator and engine.

**WARNING:** If you siphon coolant from the radiator, do not use mouth to start siphoning action. The coolant solution is **POISONOUS** and can cause death or serious illness if swallowed.

3. To check for exhaust leaks into the cooling system, drain coolant from the system until the coolant level stands just above the top of the cylinder head, then disconnect the radiator upper hose and remove the thermostat and fan belt. Start the engine and quickly accelerate several times. At the same time note any appreciable water rise or the appearance of bubbles which are indicative of exhaust gases leaking into the cooling system.

## Periodic Maintenance

It is the owner's responsibility to keep the freeze protection at a level commensurate with the area in which the vehicle will be operated. Regardless of climate, system protection should be maintained at least to -20°F., to provide adequate corrosion protection. When adding solution due to loss of coolant for any reason or in areas where temperatures lower than -20°F. may occur, a sufficient amount of an ethylene glycol base coolant that meets GM Specification 1899-M should be used.

Every two years the cooling system should be serviced by flushing with plain water, then completely refilled with a fresh solution of water and high-quality inhibited (permanent-type) glycol base coolant meeting GM Specification 1899-M, and providing freezing protection at least to -20°F. At this time, also add GM Cooling System Inhibitor and Sealer or equivalent. In Addition, Cooling System Inhibitor and Sealer should be added every fall thereafter. GM Cooling System Inhibitor retards the formation of rust or scale and is compatible with aluminum components.

**NOTE:** Alcohol or methanol base coolants or plain water are not recommended for your cooling system at any time.

Two common causes of corrosion are: (1) air suction—Air may be drawn into the system due to low liquid level in the radiator, leaky water pump or loose hose connections; (2) exhaust gas leakage—Exhaust gas may be blown into the cooling system past the cylinder head gasket or through cracks in the cylinder head and block.

## Cleaning

A good cleaning solution should be used to loosen the rust and scale before reverse flushing the cooling system. There are a number of cleaning solutions available and the manufacturer's instructions with the particular cleaner being used should always be followed.

An excellent preparation to use for this purpose is GM Cooling System Cleaner or its equivalent. The following directions for cleaning the system applies only when this type cleaner is used.

**WARNING:** If you siphon coolant from the radiator, do not use mouth to start siphoning action. The coolant solution is **POISONOUS** and can cause death or serious illness if swallowed.

1. Drain coolant from the cooling system, including the cylinder block.

**NOTE:** The V8 cylinder block drain plugs are located on both sides of the block about halfway back and on the lower edge near the oil pan rail.

The 6-cylinder block drain is located on the left side of the engine at about centerline of the block and adjacent to the flywheel housing.

2. Remove thermostat and replace thermostat housing.
3. Add the liquid portion (No. 1) of the cooling system cleaner.
4. Fill the cooling system with water to a level of about 3 inches below the top of the overflow pipe.
5. Cover the radiator and run the engine at moderate speed until engine coolant temperature reaches 180 degrees.
6. Remove cover from radiator and continue to run the engine for 20 minutes. Avoid boiling.
7. While the engine is still running, add the powder portion (No. 2) of the cooling system cleaner and continue to run the engine for 10 minutes.

**WARNING: BE CAREFUL NOT TO SCALD YOUR HANDS.**

8. At the end of this time, stop the engine, wait a few minutes and then open the engine block drain cocks. Also, remove lower hose connection.

**NOTE:** Dirt and bugs may be cleaned out of the radiator air passages by blowing out with air pressure from the back of the core. Do not bend radiator fins.

## Reverse Flushing

Reverse flushing should always be accomplished after the system is thoroughly cleaned as outlined above. Flushing is accomplished through the system in a direction opposite to the normal flow. This action causes the water to get behind the corrosion deposits and force them out.

## Radiator

1. Remove the radiator upper and lower hoses and replace the radiator cap.
2. Attach a lead-away hose at the top of the radiator.
3. Attach a new piece of hose to the radiator outlet connection and insert the flushing gun in this hose.
4. Connect the water hose of the flushing gun to a water outlet and the air hose to an air line.
5. Turn on the water and when the radiator is full, turn on the air in short blasts, allowing the radiator to fill between blasts of air.

**CAUTION:** Apply air gradually as a clogged radiator will stand only a limited pressure.

6. Continue this flushing until the water from the lead-away hose runs clear.

## Cylinder Block and Cylinder Head

1. With the thermostat removed, attach a lead-away hose to the water pump inlet and a length of new hose to the water outlet connection at the top of the engine.

**NOTE:** Disconnect the heater hose and cap connections at engine when reverse flushing engine.

2. Insert the flushing gun in the new hose.
3. Turn on the water and when the engine water jacket is full, turn on the air in short blasts.
4. Continue this flushing until the water from the lead-away hose runs clear.

#### Heater Core

1. Remove water outlet hose from heater core pipe.
2. Remove inlet hose from engine connection.
3. Insert flushing gun and flush heater core. Care must be taken when applying air pressure to prevent damage to the core.

#### Fan Belt Adjustment

1. Loosen bolts at Delcotron mounting.
2. Pull Decotron away from engine until desired tension reading is obtained with a strand tension gauge. Refer to "Engine Tune Up Specifications".
3. Tighten all Delcotron bolts securely.

#### Radiator Cap

The radiator cap should be washed with clean water and pressure checked at regular tune-up intervals. Inspect rubber seal on cap for tears or cracks. Install radiator cap on tester (fig. 4). If the pressure cap will not hold pressure or does not release at the proper pressure, replace the cap.

#### Thermostat

The thermostat consists of a restriction valve actuated by a thermostatic element. This is mounted in the housing at the cylinder head water outlet above the water pump. Thermostats are designed to open and close at predetermined temperatures and if not operating properly should be removed and tested as follows:

#### Replacement

1. Remove radiator to water outlet hose.
2. Remove thermostat housing bolts and remove water outlet and gasket from thermostat housing (fig. 11).



Fig. 10—Pressure Checking Radiator Cap

3. Inspect thermostat valve to make sure it is in good condition.
4. Place thermostat in a 33% glycol solution 25° above the temperature stamped on the thermostat valve.
5. Submerge the valve completely and agitate the water thoroughly. Under this condition the valve should open fully.
6. Remove the thermostat and place in a 33% glycol solution 10° below temperature indicated on the valve.
7. With valve completely submerged and water agitated thoroughly, the valve should close completely.
8. At the end of this time, stop the engine, wait a few minutes and then open the drain cocks.
9. Refill cooling system.

#### Thermostatic Fan Clutch

##### Replacement

All mating surfaces (water pump hub and fan clutch hub) should be inspected for smooth mating surfaces and reworked as necessary to eliminate burrs or other imperfections. Except for the fan belt, components should be assembled to the engine (See Water Pump Removal and Installation Procedures). Radial run-out should be checked as follows:

1. Secure the fan blade to prevent rotation. (See Figure 12.)
2. Mount a dial indicator (.001 graduations) to the engine and place the indicator pointer on the fan blade spider. Preferably on the longest band or space on the spider. (See Figure 13.)
3. Rotate the water pump pulley in one direction and note the total amount of indicator needle



Fig. 11—Replacing Thermostat



Fig. 12—Securing Fan Blade

movement. This represents the total radial run-out. Mark the point on the pulley at which the highest reading is obtained.

4. If the total indicator reading is less than .006 inch, the assembly is within specification. Install fan belt and adjust.

If the total indicator run-out exceeds .006 inch, proceed to Step 5.

5. Divide the total indicator reading in half and obtain this thickness from shim stock (1/2 x 3/4) and rework per Figure 8. Place this shim pack between the water pump pulley and fan clutch hub at the bolt closest to the point marked on the pulley in Step 3. If the mark on the pulley is between two bolts so that it is difficult to determine which bolt is closest, place two shim packs; one under each bolt on either side of the mark. (See Figure 15.)

**Bolt Torque Sequence**

- a. When one shim pack is used, first, torque the bolt over which the shim pack has been placed; second, the bolt opposite the first; and finally, the other two. Recommended torque is 25 lbs. ft.

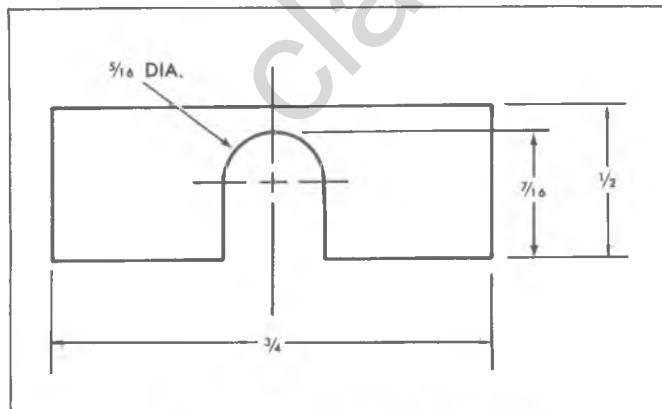

Fig. 14—Shim Fabrication Dimensions



Fig. 13 —Checking Run-Out

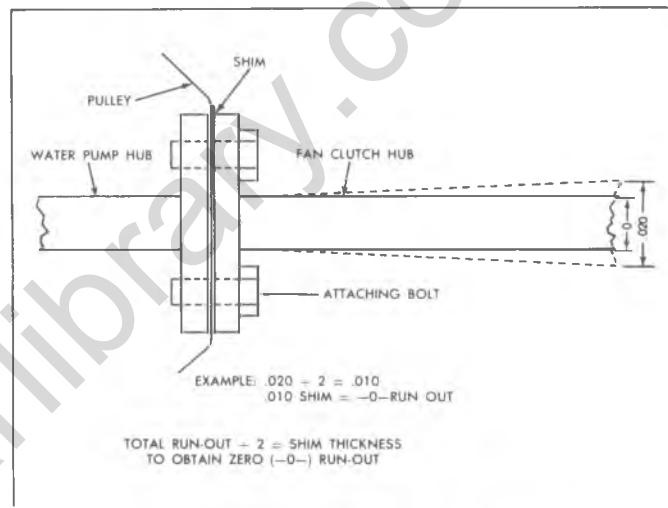

Fig. 15—Determining Shim Placement

- b. When two shim packs are used, each bolt must be torqued partially; then to full torque alternating between opposite bolts; then the other two bolts in the same manner. Recommended torque is 25 lbs. ft.

NOTE: Excessive run-out may result if the above sequence and recommended torque is not used.

6. Recheck total indicator run-out to verify that run-out is within .006 inch. Install fan belt and adjust.

**Water Pump**

**Removal**

**WARNING:** If you siphon coolant from the radiator, do not use mouth to start siphoning action. The coolant solution is **POISONOUS** and can cause death or serious illness if swallowed.

1. Drain coolant from the radiator and break loose the fan pulley bolts.
2. Disconnect heater hose, radiator lower hose and bypass hose (as required) at water pump.
3. Loosen Delcotron and remove fan belt then remove fan bolts, fan and pulley.

**CAUTION:** *If a fan blade is bent or damaged in any way, no attempt should be made to repair and reuse the damaged part. A bent or damaged fan assembly should always be replaced with a new fan assembly.*

It is essential that fan assemblies remain in proper balance and proper balance cannot be assured once a fan assembly has been bent or damaged. A fan assembly that is not in proper balance could fail and fly apart during subsequent use creating an extremely dangerous condition.

**NOTE:** Thermostatic fan clutches must be kept in an "in-car" position. When removed from the car the assembly should be supported so that the clutch disc remains in a

vertical plane to prevent silicone fluid leakage.

4. Remove pump to cylinder block bolts and remove pump and old gasket from engine.

**NOTE:** On in line engines, pull the pump straight out of the block first, to avoid damage to impeller.

#### Installation

1. Install pump assembly on cylinder block then, using a new, sealer coated, pump-to-block gasket tighten bolts securely.
2. Install pump pulley and fan on pump hub and tighten bolts securely.

**NOTE:** A guide stud (5/16"-24 x 1" bolt with the head removed) installed in one hole of the fan will aid in aligning hub, pulley and fan. Remove stud after starting the remaining three bolts.

3. Connect hoses and fill cooling system.
4. Install fan belt and adjust as previously outlined.
5. Start engine and check for leaks.

## DIAGNOSIS

If the cooling system requires frequent addition of coolant in order to maintain the proper level in the radiator, check all units and connections in the cooling system for evidence of leakage. Inspection should be made with cooling system cold. Small leaks which may show dampness or dripping can easily escape detection when the engine is hot, due to the rapid evaporation of coolant. Tell-tale stains of grayish white or rusty color, or dye stains from anti-freeze, at joints in cooling system are almost always sure signs of small leaks even though there appears to be no damage.

Air may be drawn into the cooling system through leakage at the water pump seal. Gas may be forced into the cooling system through leakage at the cylinder head gasket even though the leakage is not sufficient to allow water to enter the combustion chamber.

### COOLING SYSTEM CHECKS

To check for exhaust leaks into the cooling system, drain the system until the coolant level stands just above the top of the cylinder head, then disconnect the radiator upper hose and remove the thermostat and fan belt. Start the engine and quickly accelerate several times. At the same time note any appreciable water rise or the appearance of bubbles which are indicative of exhaust gases leaking into the cooling system.

Water pump operation may be checked by running the engine while squeezing the radiator upper hose. A pressure surge should be felt. Check for a plugged vent-hole in pump.

Test for restriction in the radiator, by warming the engine up and then turning the engine off and feeling the radiator. The radiator should be hot along the left side and warm along the right side, with an even temperature rise from right to left. Cold spots in the radiator indicate clogged sections.

An operational check of the thermostat can be made by hanging thermostat on a hook in a 33% glycol solution 25° above the temperature stamped on the thermostat valve. Submerge the valve completely and if the valve should open. Remove the thermostat and place in a 33% glycol solution 10° below temperature indicated on the valve. With valve completely submerged and water agitated thoroughly, the valve should close completely.

### Coolant Loss

1. Check for crack in block. Pull engine oil dip-stick to check for water in crankcase.

## 6K-12 ENGINE COOLING

2. Remove rocker arm covers and check for cracked cylinder head.
3. Remove cylinder heads and check gaskets. While heads are off, check for cracks in heads or block.

### Overheating

1. Check to see that the radiator cap seats in radiator filler neck and releases at specified pressure (15 lb.).
2. Check coolant level.
3. Check temperature sending unit and/or gauge.
4. Check engine thermostat.
5. Check fan belt for excessive looseness.
6. Check for punctures in radiator, ruptured or

disconnected hoses, loose pressure cap or use of low boiling point antifreeze. These conditions prevent cooling system from maintaining proper pressure.

7. Clean debris from radiator and/or condenser.
8. Check engine operation to make sure tune-up is not needed. Improper timing may cause overheating.
9. Check for driving conditions which may cause overheating. Prolonged idling, start and stop driving in long lines of traffic on hot days, climbing steep grades on hot days, etc. will occasionally cause coolant to boil.
10. Clean cooling system.
11. Remove cylinder heads and check water passages in heads and block for obstructions.

Classiccarlibrary.com



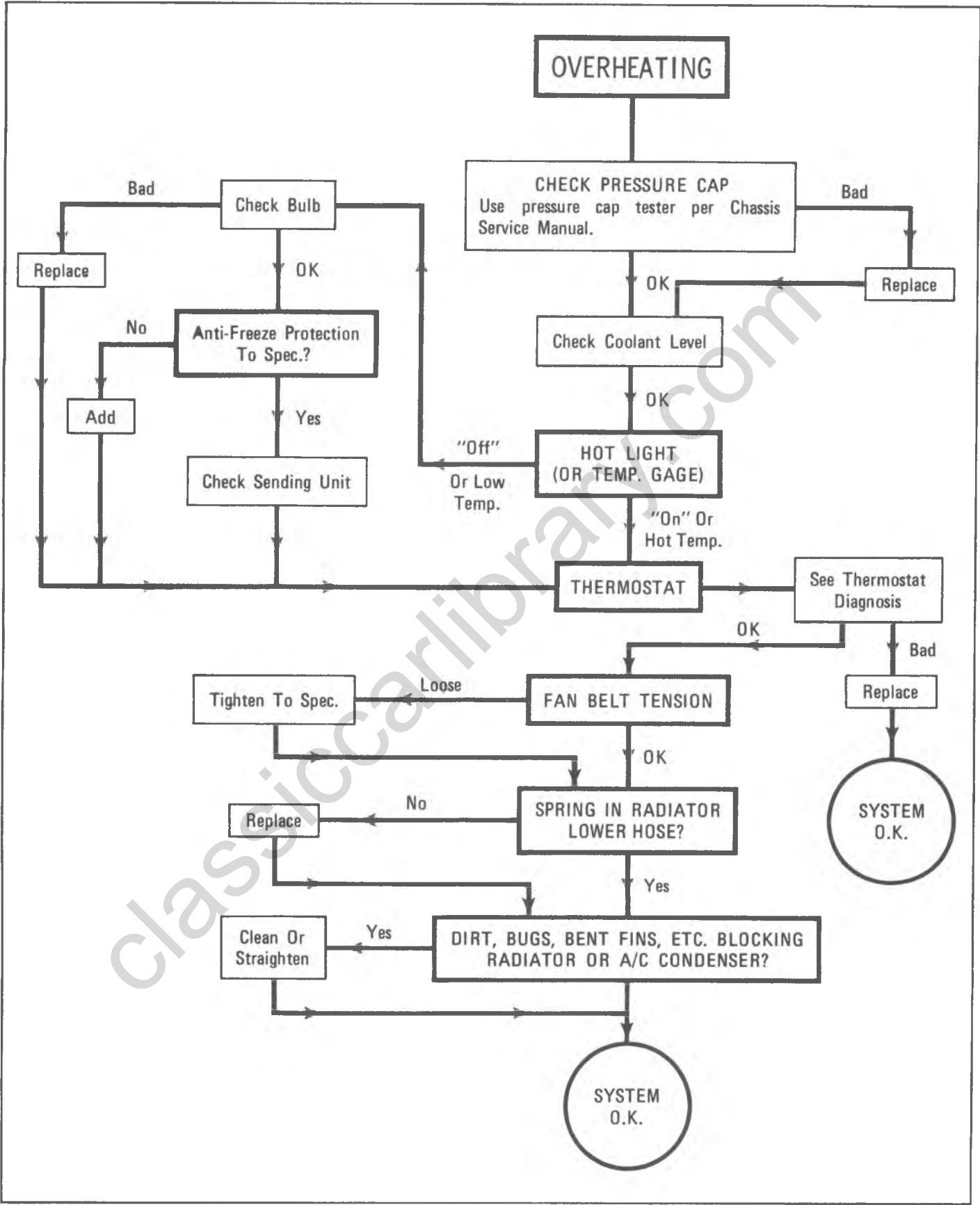

Fig. 16—Overheating Chart

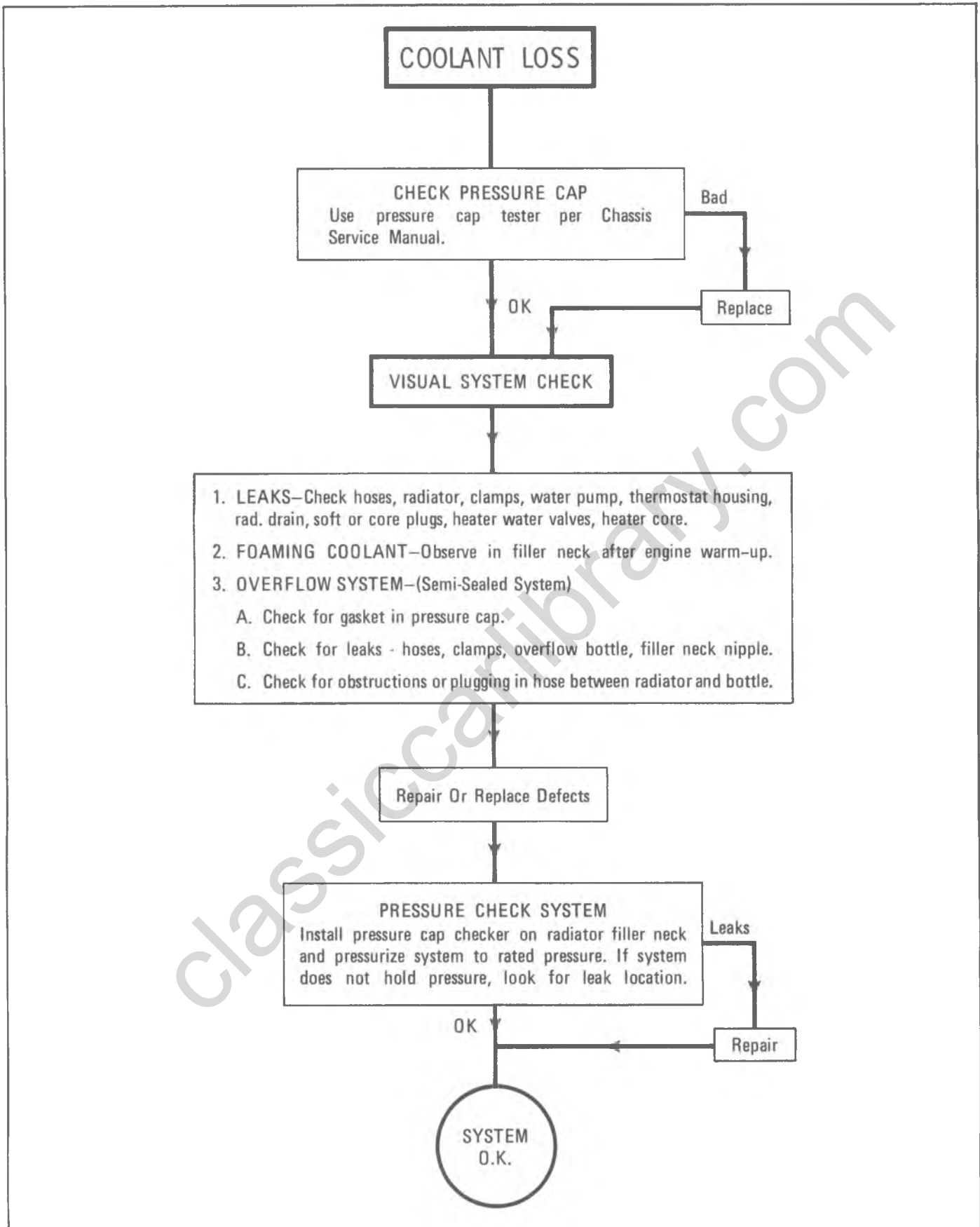

Fig. 17—Coolant Loss Chart

## SECTION 6M

# ENGINE FUEL

NOTE: Also refer to "Emission Control Systems Booklet" and "Maintenance Schedule Folder" for warranty and maintenance information.

### CONTENTS OF THIS SECTION

Description .....	6M-1	Service Operations .....	6M-24
Theory of Operation .....	6M-2	Diagnosis .....	6M-39
Maintenance and Adjustments .....	6M-15	Special Tools .....	6M-64

## DESCRIPTION

This Section of the 1974 Truck Service Manual covers the above "Contents" items as they relate to carburetors and the engine fuel system. This service section also includes, carburetor removal and installation and external adjustments for all 10-30 series trucks, in addition to, maintenance procedures for choke coils, throttle linkage, accelerator and choke controls, air cleaners and fuel filters. For carburetor identification, overhaul procedures, assembly and disassembly of components, and internal carburetor adjustments, refer to Section 6M, of the Overhaul Manual, under the carburetor being serviced. In addition to carburetor adjustment specifications, also refer to Specifications at the end of the manual for carburetor application and type.

Carburetors used with 10-30 Trucks are designed to meet the particular requirements of engine, transmission and vehicles. Carburetors that look alike are not always interchangeable. (Refer to carburetor part number and/or specifications). Service procedures for the various carburetors are similar, therefore, typical illustrations and procedures are used except where specific illustrations or procedures are necessary to clarify the operation.

### MODEL MV (1bbl.) CARBURETOR

The Model MV carburetor is a single bore down-draft carburetor using a triple venturi in conjunction with a plain tube nozzle.

Fuel flow through the main metering system is controlled by a fixed orifice jet. The power enrichment system is used to provide good performance during moderate to heavy accelerations.

The Model MV carburetor has an automatic choke system. The vacuum diaphragm unit is mounted externally on the air horn. The choke coil is mounted on the manifold and is connected to the choke valve shaft by a rod.

An integral fuel inlet filter is mounted in the fuel bowl

behind the fuel inlet nut to give maximum filtration of incoming fuel.

Other features of the Model MV include an aluminum throttle body, and a thick throttle body to bowl insulator gasket. The carburetor has internally balanced venting through a vent hole in the air horn, which leads from the bowl into the bore beneath the air cleaner.

The carburetor model identification is stamped on a vertical portion of the float bowl adjacent to the fuel inlet nut. If replacing the float bowl, follow the instructions contained in the service package to transfer the identification.

An electrically operated idle stop solenoid is used on all MV models. The solenoid mounts on the carburetor float bowl and replaces the normal carburetor idle stop screw. The curb idle speed setting is made by turning the electrically operated idle stop solenoid in the boss located on the carburetor bowl. See "Idle Stop Solenoid Adjustment".

The idle mixture screw has a limiter cap installed. The mixture screw is pre-set at factory and capped and no further adjustment is required.

An Exhaust Gas Recirculation system (E.G.R.) is used on all Light Duty Emission applications for 1974 to control oxides of nitrogen. The vacuum supply port necessary to operate the recirculation valve is located in the throttle body and connects through a channel to a tube which is located at the top of the air horn casting. See Idle System for port location and operation.

### MODEL 2GV (2 bbl.) SAE 1-1/2 CARBURETOR

The Model 2G, 2GV (large bore 1-1/2") carburetors include the features:

1. The carburetors are calibrated to meet current engine requirements.
2. The internal float bowl vent hole located in the air horn is enlarged for improved float bowl venting

## 6M-2 ENGINE FUEL

and vapor handling. As there are no external vents, the carburetor is completely internally balanced.

3. Plastic main well inserts in the main fuel wells provide improved fuel metering for the main metering system. The use of the plastic main well inserts provide improved fuel control in the off-idle, transfer and part throttle ranges of operation.

The plastic main well inserts surround the main fuel discharge nozzles and are removable for carburetor disassembly and cleaning purposes.

4. An exhaust gas recirculation system (E.G.R.) is used on all applications to control oxides of nitrogen emissions. The vacuum supply necessary to operate the exhaust gas recirculation valve is obtained through timed vacuum ports in the throttle body which connects through a channel to a tube which is located beneath the spark tube at the side of the float bowl.

As the throttle valve is opened beyond the idle position, the first E.G.R. port is exposed to manifold vacuum, to supply a signal to the E.G.R. valve located on the engine manifold. The second port in the throttle body is located mid-way between the top of the valve and the throttle body casting and is positioned higher to act as an air bleed for the lower port, thereby, modulating the amount of vacuum signal supplied by it.

As the throttle valve is opened further in the part throttle range, at higher air flows, the vacuum signal decreases at the lower port. The upper port then ceases to function as an air bleed and is gradually exposed to manifold vacuum to supplement the signal at the lower port. In this way, the E.G.R. valve operation is timed for precise metering of exhaust gases to the intake manifold, so that the right amount can be added to the inlet mixtures, for proper control of the oxides of nitrogen.

The exhaust gas recirculation system does not operate during the normal curb engine idle.

5. The steps on the fast idle cam have been revised to improve engine performance during the warm-up period.
6. A pump fill passage in the accelerator pump system has been added to give improved pump performance.

### MODEL 4MV (4 bbl.) QUADRAJET CARBURETOR

The Model 4MV carburetor has many features including

the following:

1. All models are calibrated to assist in meeting emission requirements.
2. The highest step on the fast idle cam length improves choke engine operation during the warm-up period.

NOTE: Light Duty Emissions Only:

An exhaust gas recirculation system is used to control oxides of nitrogen emissions. Dual punched ports are located in the carburetor throttle body bore to supply a vacuum signal for operation of the exhaust gas recirculation valve.

Two punched ports, one just above the throttle valve and one mid-way between the throttle valve and upper surface of the throttle body are located in the primary bore.

As the primary throttle valve is opened beyond the idle position, the first vacuum port for the E.G.R. system is exposed to manifold vacuum to supply a vacuum signal to the E.G.R. valve. To control the vacuum signal at the lower port, the upper port bleeds air into the vacuum channel and modulates the amount of vacuum signal supplied by the lower E.G.R. port. In this manner, the E.G.R. valve can be timed for precise metering of exhaust gases to the intake manifold dependent upon location of the ports in the carburetor bore and by the degree of throttle valve opening.

As the primary throttle valve is opened further in the port throttle range at higher air flows the vacuum signal decreases at the lower ports. At this time the upper port ceases to function as an air bleed and is gradually exposed to manifold vacuum to supplement the vacuum signal at the lower port and help maintain correct E.G.R. valve position.

The upper and lower vacuum ports connect to a cavity in the throttle body which, in turn, through a passage supply the vacuum signal to the E.G.R. tube pressed into the front corner of the throttle body. The tube in the throttle body is connected by a hose to the E.G.R. valve located on the engine manifold.

The E.G.R. valve remains closed during periods of engine idle and deceleration to prevent rough idle from excessive exhaust gas contamination in the idle air/fuel mixtures.

## THEORY OF OPERATION

### INDEX

Theory of Operation.....	6M-2	Atomization .....	6M-3
What is a Carburetor.....	6M-3	Metering.....	6M-4
Purpose of a Carburetor.....	6M-3	Air Measurement.....	6M-5

Fuel Metering.....	6M-5	Float System.....	6M-9
Venturi Principle.....	6M-6	Idle System.....	6M-10
Distribution.....	6M-7	Main Metering System.....	6M-11
Fuel-Air Requirements .....	6M-7	Power System.....	6M-12
Power vs. Economy .....	6M-8	Pump System .....	6M-12
Cold Starts.....	6M-9	Choke System .....	6M-13
Basic Carburetor Systems .....	6M-9		

## WHAT IS A CARBURETOR

A carburetor is a metering device which mixes fuel with air in the correct proportion and delivers them to the engine cylinders as a combustible mixture. The design of a carburetor is based on the application of natural principles to the job of providing compatible air-fuel mixtures to meet exhaust emission standards and driveability for the varying engine requirements. Just as it is necessary to understand the range of fuel mixtures required for each operational phase, so must the serviceman basically understand the natural forces applied by the design for delivery of these mixtures.

## PURPOSE OF A CARBURETOR

The purpose of a carburetor on a gasoline engine is to meter, atomize, and distribute the fuel throughout the air flowing into the engine (Fig. 1). These functions are designed into the carburetor and are carried out by the carburetor automatically over a wide range of engine operating conditions, such as varying engine speeds, load, and operating temperature.

The carburetor also regulates the amount of air-fuel mixture which flows to the engine. It is this mixture flow regulation which gives the driver control of the engine speed.

Regardless of engine speed or load, the carburetor must automatically perform its three basic functions.

The automotive carburetor is an intricate device;

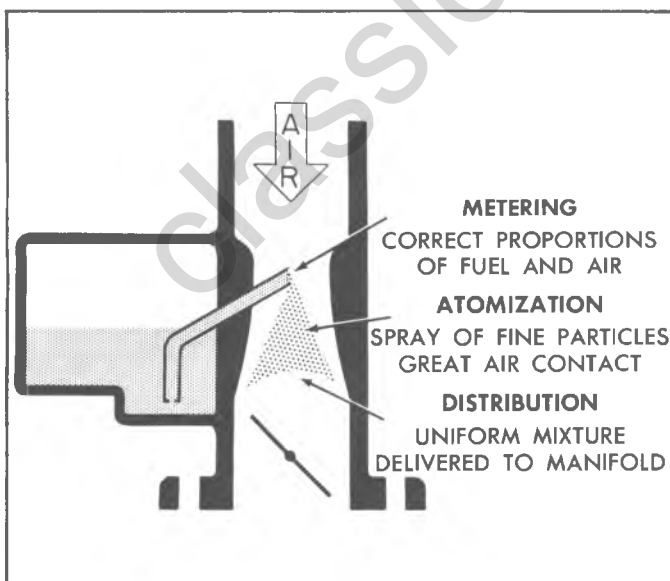

Fig. 1--Basic Functions

however, when studied one phase at a time, the functions of the carburetor are easily understood.

As mentioned above, the three main functions of the carburetor are to meter, atomize and distribute the fuel.

## ATOMIZATION

The engine's source of fuel for power is gasoline. Before gasoline can be used as fuel for an engine, it must be atomized which means breaking the fuel into fine particles so that it can be mixed with air to form a combustible mixture. Contrary to popular belief, gasoline in its liquid state is not combustible; only gasoline vapor will burn. A common example of this is a cigarette lighter which works fine indoors but then can't be lit after you've been outdoors in the cold for awhile. At warmer temperatures, fuels vaporize quickly and so can be ignited easily but at lower temperatures, evaporation is slower and accordingly ignition is impossible or, at least, difficult because of insufficient vapor.

While this analogy is quite simple, it is an illustration of the basic problems of carburetor design; that is, the provision of combustible fuel mixtures over a broad range of temperature and operating conditions. The complexity of design problems continues to mount each year due to a constant effort to reduce exhaust emissions and at the same time improve operating conditions.

To be combustible, gasoline must vaporize. Vaporization is the act of changing from a liquid to a gas and this change of state occurs only when the liquid absorbs enough heat to boil. This is what happens in a tea kettle to change water to water vapor, or steam. Heat is transferred to the water, raising its temperature until it finally reaches the boiling point, at which time the water changes to steam and is carried off to atmosphere in this gaseous form. At sea level, the water will boil at 212°F but at high altitudes, less heat is required for water to boil due to lower atmospheric pressure. This is known as the temperature-pressure relationship; that is, as the pressure is reduced, the boiling point is reduced. This law, combined with a process known as atomization, has important applications in the transformation of liquid gasoline to a vapor for use in combustion.

In a carburetor (Fig. 2), gasoline is discharged into the incoming air stream as a spray and the spray is then atomized, or torn into fine droplets to form a mist. The resulting air-fuel mixture is drawn into the intake manifold. At this point, the change of state occurs and the fuel "mist" vaporizes as the result of several factors.

Since the pressure in the intake manifold is far less than

## 6M-4 ENGINE FUEL

atmosphere, the boiling point of the gasoline is lowered considerably. At this reduced pressure, latent heat absorbed from the many air particles surrounding each fuel particle causes some vaporization, which is further aided by heat on the intake manifold floor.

Because complete fuel vaporization is the result of many factors (ambient temperature, fuel temperature, manifold vacuum, and intake manifold temperature), it is easy to see that anything which reduces any one of these factors will adversely effect vaporization and thus reduce fuel economy and increase exhaust emissions. Some examples would be cold weather, an inoperative exhaust heat control valve, and high overlap camshafts and/or heavy throttle demands. While the effects from lower temperatures are obvious, reduction of manifold vacuum either by valve timing or heavy throttle operation are highly detrimental to fuel economy due to the higher pressures (and boiling points) resulting in the intake manifold which reduces the amount of fuel vaporization which will occur by the time the charge enters the combustion chamber. Fuel not vaporized at the time of induction is, to a large extent, exhausted unburned from the combustion chamber and can cause high hydrocarbon exhaust emissions.

We know that gasoline, for combustion, must be vaporized or as the change of state can be loosely considered, absorbed by air. However, this requirement is further limited by the amount of air that the fuel vapor is absorbed by. Combustible mixtures in an engine are limited by the following proportions, or ratios, of air to gasoline: eight parts air to one part gasoline is the richest mixture that will fire regularly and a mixture of 18 1/2 parts air to one part gasoline is the leanest mixture that will fire without missing in an engine. Mixtures leaner than 18.5:1 tend to cause misfire. From an automotive standpoint these ratios represent the mixture extremes that an engine can tolerate, but these

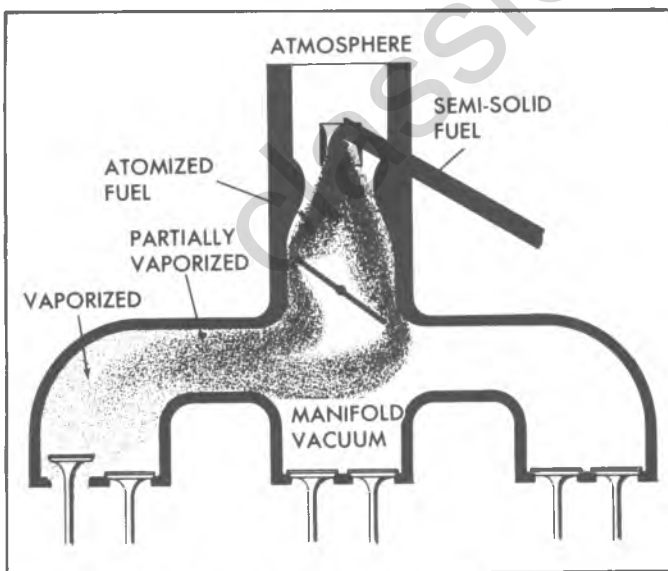

Fig. 2--Fuel Transition--Atomization and Vaporization

limits do not provide the two conditions most sought. The most desired ratios are a mixture that will produce the most power per pound of gasoline and a mixture that will provide the best economy or most miles per pound of fuel with the least exhaust emissions.

For those who may be wondering why we are speaking in terms of "pounds" of fuel instead of our more usual gallon measure, let's take a moment for clarification. Actually the reason we speak in terms of pounds rather than gallons is so that the ratio, or air-fuel mixture proportion, terms can be smaller numbers. For example, for most efficient (and economical) combustion, 9000 gallons of air are required to burn one gallon of gasoline, hence an air-fuel ratio of 9000:1 by volume.

Obviously, proportions with such numerical differences would be difficult to comprehend and extremely awkward to work with for experimentation and design.

By using weight as the base, let's make the same comparison (Fig. 3). A gallon of gasoline weighs about six pounds whereas 100 gallons of air are needed to produce one pound of air. Converting our volume air-fuel ratio to weight, we find that 9000 gallons of air weighs 90 pounds (100 gals. equals 1 lb., therefore 9000 divided by 10090 lbs.) and one gallon of gasoline weighs 6 pounds. 90 divided by 6 equals 15 therefore we arrive at an air-fuel ratio of 15:1 by weight.

## METERING

Good combustion demands a correct mixture ratio between fuel and air. To release all possible energy by combustion, the right amount of fuel must be mixed with a given amount of air. The metering job of the carburetor is to furnish the proper air-fuel ratio for all

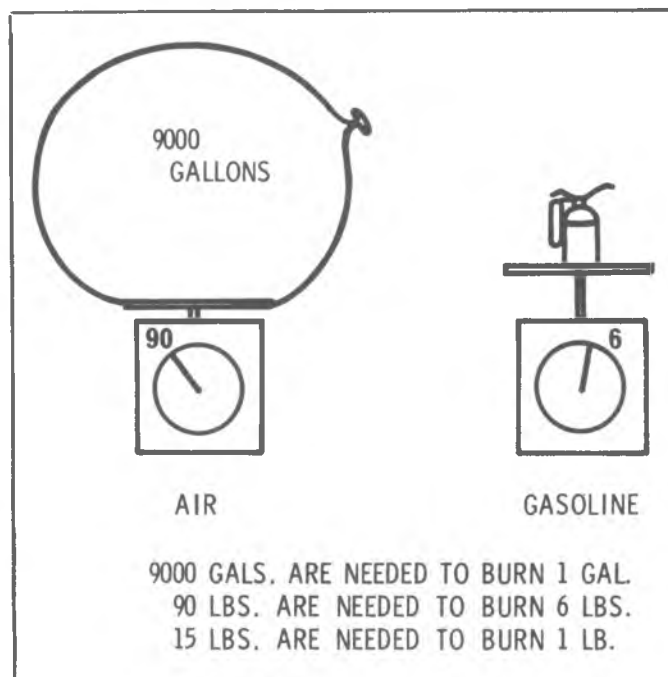

Fig. 3--Air-Fuel Weight Ratio

conditions, so that the engine operation will neither be too lean for power requirements nor too rich for economy (Fig. 4), while still meeting prime requirements of low emissions.

## AIR MEASUREMENT

Air flow through a pipe will create a pressure drop within the pipe proportional to the speed of the air. Thus, for a given pipe size, the pressure difference between the outside air and the pressure within the pipe provides a direct means of measuring the amount of air flowing through the pipe.

The simplest means of measuring the pressure difference between atmosphere and the pressure inside the pipe, is to insert a U-tube partially filled with water into the pipe as illustrated (Fig. 5). Since one end is open to atmosphere, the water level will rise on the low pressure (or pipe side) because water will flow toward an area of lower pressure. Actually, the water is being pushed into a state of balance by the weight of the air at the end of the U-tube open to atmosphere vacuum. A common example of the force exerted by the weight of air is a drinking straw (Fig. 6). As you suck on a straw, the air within the straw is removed, thus creating a low pressure or vacuum. The weight, or pressure, of the air on the surface of the liquid in the glass then forces the liquid up the straw to fill the void. The important thing to understand is that fluid is not pulled by the vacuum but is rather pushed into the vacuum or low pressure area by the weight of the air pressing on the surface of the liquid.

The difference in pressure, or vacuum, is expressed by measuring the distance between the two heads of water in the U-tube, or inches of water. Low vacuum is generally expressed in inches of water but higher vacuum, such as manifold vacuum, is usually measured

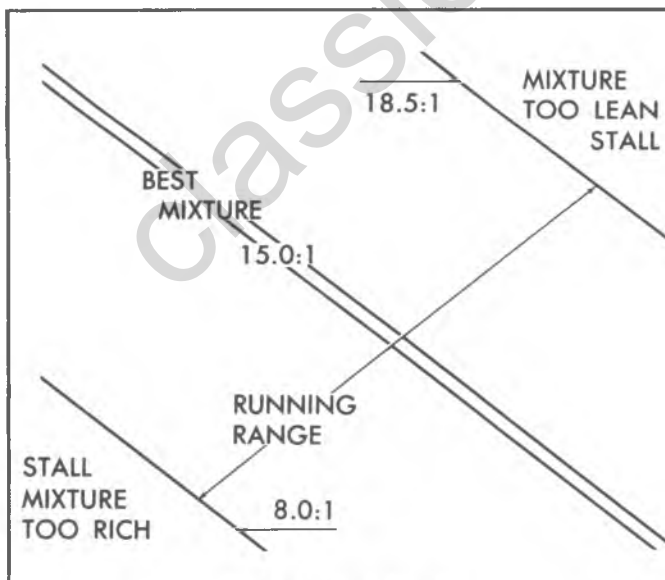

Fig. 4--Metering Limits

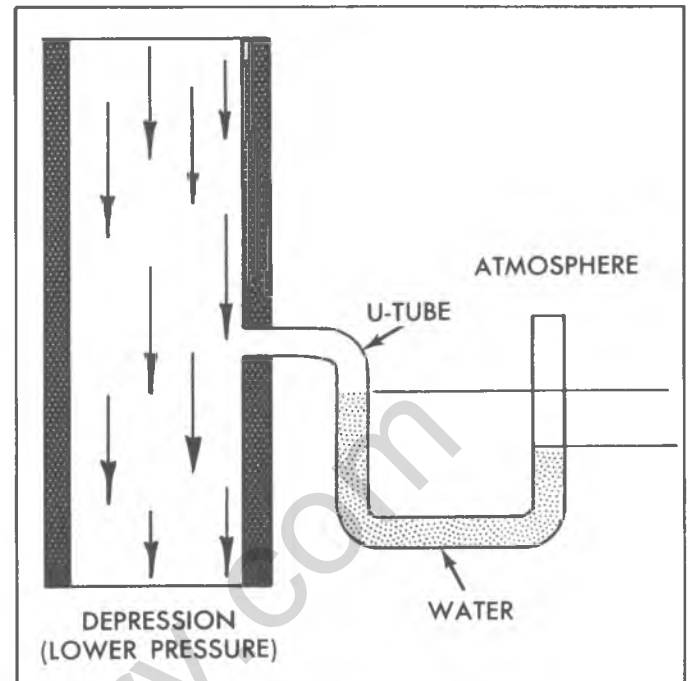

Fig. 5--Air Flow Measurement

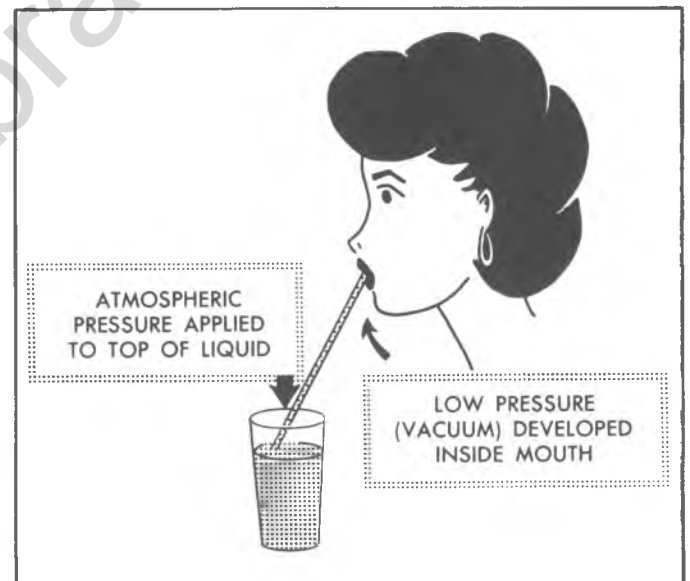

Fig. 6--Vacuum Principle

in inches of mercury because mercury is approximately 13 1/2 times heavier than water and thus provides a more convenient valve for measuring the larger pressure differences.

## FUEL METERING

As shown in measurement of air flow with the U-tube, fluids flow when there is a difference in pressure and will always flow toward the lower pressure. If the fluid level in the U-tube were higher, the reduced pressure within the pipe would cause the fluid to flow into the pipe.

## 6M-6 ENGINE FUEL

Further, if a means were provided to maintain the fluid level at a desired height in the U-tube, the amount of fluid flow would be proportional to the pressure difference caused by the air flow through the pipe. Carburetors operate on the basic principle of pressure difference.

A basic carburetor is an adaptation of the U-tube (Fig. 7). The fuel side, open to atmospheric pressure, inside of air cleaner (internal venting), is enlarged to create a reservoir and fitted with a float valve to maintain a constant level of fuel. To control the quantity of fuel delivered, a jet or metering orifice is screwed into the base of the main nozzle. A streamlined restriction, known as a venturi, is added to the air intake side to create an additional pressure drop for a given rate of air flow, dictated by upper diameter of the pipe. Finally, a throttle valve is added to control the volume of air-fuel mixture admitted.

Applying the basic carburetor to an engine, air flow is initiated by the pumping action of the pistons and the intake and exhaust valve action. As the piston moves downward during the admission or intake stroke, the inlet valve is open causing air to rush in through the carburetor and manifold to fill the space left by the downward piston travel. At engine operating speeds, especially with multi-cylinder engines, the air flow through the carburetor is nearly constant. The amount of air flow, and accordingly the fuel picked up, is controlled by the opening allowed by the throttle valve.

### VENTURI PRINCIPLE (FIG. 8)

To obtain a greater pressure drop at the tip of the nozzle to cause the fuel to flow, the principle of increasing the air velocity to create a low pressure area is used. A device called the "venturi" is used to increase the air velocity and lower the pressure at the discharge nozzle. The increased pressure differential between that of the fuel bowl and at the carburetor throat increases fuel flow

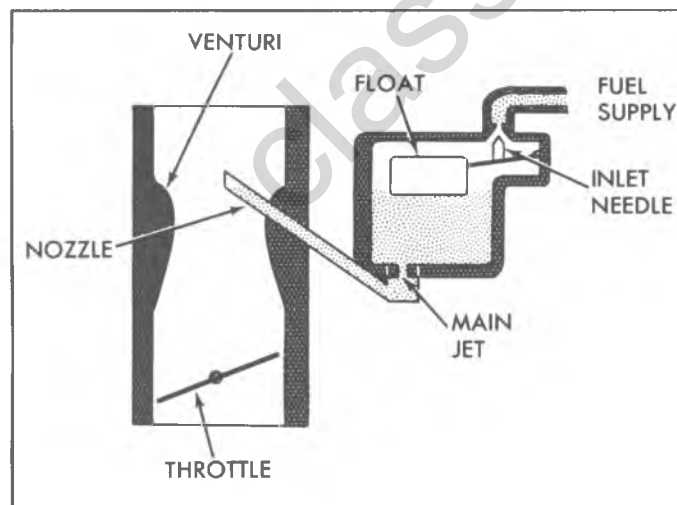

Fig. 7--Basic Carburetor

sufficiently, at a given air flow, so that the resulting air-fuel proportions result in a combustible mixture.

For example, a carburetor with a 1 1/2" pipe will supply the volume of air required for a given displacement engine. However, the pressure drop within the carburetor throat is insufficient to cause enough fuel to flow into the carburetor at the desired speed to create a combustible fuel mixture due to the large weight difference between air and gasoline. By necking down the inner diameter of the carburetor throat into a venturi, the air flow is forced to speed up at the restriction area, thus further reducing air pressure and increasing fuel flow proportionately to achieve the desired mixture.

To be most effective, the venturi must be designed for a certain curvature and length. The venturi design can be tailored to provide fuel flow under any condition of air flow. However, a small venturi may restrict high speed engine operation and a large venturi will not provide enough pressure differential for low speed operation. The production venturi size is usually a compromise to provide adequate low and high speed operation.

The carburetor discharge nozzle is located in the center of the venturi throat to take advantage of the maximum pressure drop and promote atomization of the fuel. The large venturi, cast in the carburetor bore, is called the primary or main venturi.

Most carburetors use a primary and one or most boost venturis. The boost venturi is usually located over the primary with its discharge end in the low pressure area of the primary. The purpose of the boost venturi is to further lower the pressure at the nozzle. Additional boost

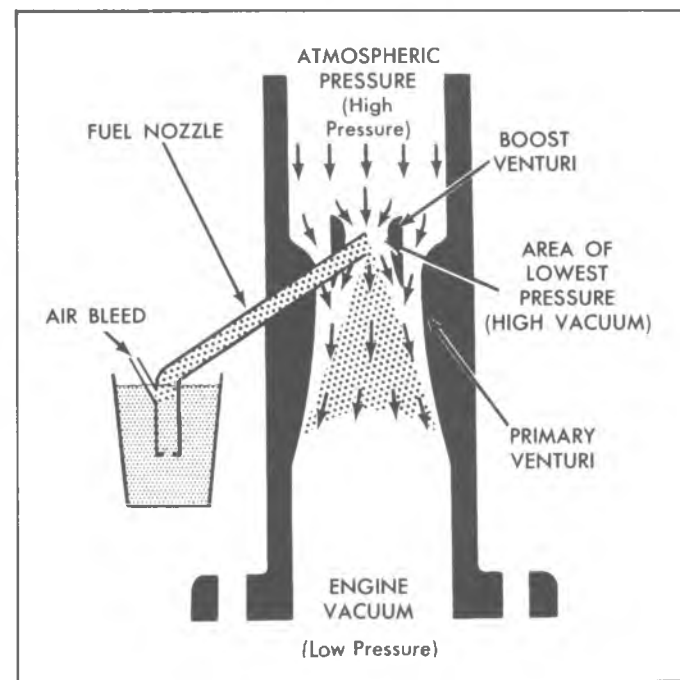

Fig. 8--Venturi Principle



venturis may be used for finer control of pressure drop but at high speed they tend to restrict air flow to the engine.

Because actual venturi size is a compromise, two- and four-barrel carburetors are used where requirements are extreme. A two-barrel carburetor allows use of smaller venturi for improved low speed operation yet gives relatively good high speed operation due to the larger throttle area provided by the two throttle valves. The primary side of a four-barrel carburetor is designed much the same as the two-barrel carburetor with small venturi for low speed economy. The secondary side of a four-barrel carburetor uses large bores and venturi for extremely good high speed breathing. The secondary side of the four-barrel carburetor operates only at high degree primary throttle openings or when performance is required.

## DISTRIBUTION

For good combustion and smooth engine operation, the air and fuel must be thoroughly and uniformly mixed, delivered in equal quantities to each cylinder and evenly distributed within the combustion chamber.

Good distribution requires good vaporization. A gaseous mixture will travel much more easily around corners in the manifold and engine, while liquid particles, being relatively heavy, will try to continue in one direction and will hit the walls of the manifold or travel on to another cylinder.

As an example, consider a six cylinder engine with the carburetor mounted at the center of the manifold. The mixture for cylinder 4, 5, and 6 will initially travel towards the rear of the engine.

If 5 is on the intake stroke, the mixture will be drawn sharply around the corner to 5 at right angles to the original direction (Fig. 9). The large drops of gasoline won't make such a sharp turn and will continue in their path to the rear of the manifold, where they will

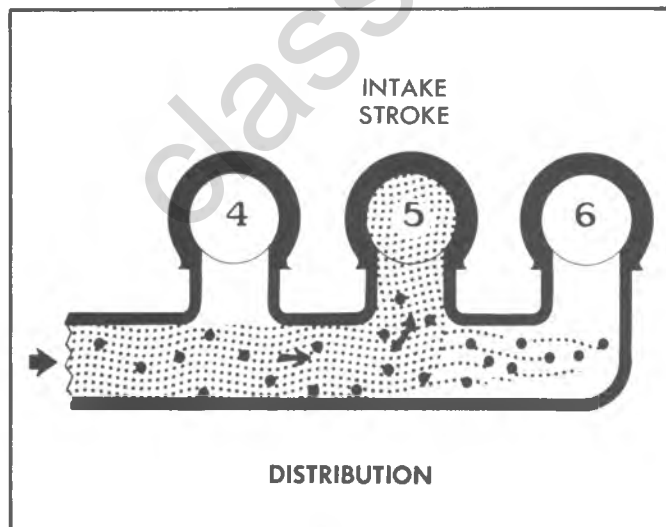

Fig. 9--Distribution

receives a leaner mixture and 6 receives a richer mixture than originally entered the manifold.

To compensate for these problems, manifolds are tailored to the engines to minimize the sharp corners and provide as smooth a flow as possible. The carburetor's principal job in distribution is to break up the fuel as finely as possible and furnish a uniformly vaporized mixture to the manifold.

## FUEL-AIR REQUIREMENTS

(Fig. 10)

As previously mentioned, we know that without regard for efficiency, an air-fuel mixture within the range of 8-to-1 and 18 1/2-to-1 must be provided for an automobile engine to run. More practically the air-fuel ratio should be utilized which would allow peak power output, minimum emissions, and peak fuel economy.

Unfortunately, no single air-fuel ratio can provide both the above peak conditions. Tests prove the best power output is obtained using a 12.5-13.5:1 mixture whereas best fuel economy results using a 15.0-16.0:1 mixture. Since an automobile engine must be able to provide both requirements, obviously no compromise fuel ratio would be satisfactory. Therefore a carburetor must be able to quickly match varying engine requirements with the best possible fuel mixture to meet the demand. This means that fuel ratios must be provided not only for the demand but caused by light speed variations and changing engine load conditions such as a moderate grade.

One of the reasons that the air-fuel ratio must be varied is because of imperfect conditions within the combustion chamber. Exhaust gases remaining in the cylinder dilute the fresh charge. The fuel and air are not perfectly mixed, miniature droplets of unvaporized fuel being

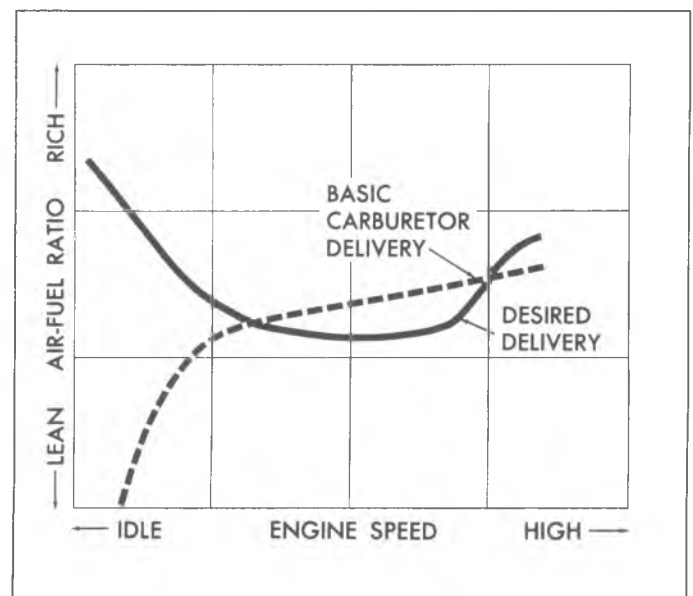

Fig. 10--Air-Fuel Flow

## 6M-8 ENGINE FUEL

carried along by the mixture of air and evaporated fuel. The intake manifold itself does not deliver exactly equal air-fuel mixtures to all cylinders. The air-fuel ratio must therefore be adjusted, depending on such factors as engine speed and whether power or economy is desired.

### POWER VS. ECONOMY

If maximum power is desired, it is necessary to burn all the oxygen in the air, since the power-production ability of an engine is limited by the amount of air it can take in. Additional fuel must therefore be added to insure that each molecule of oxygen combined with the necessary fuel. Thus, the mixture required for maximum power usually falls in the range from 12 to 13.5-to-1, being "richer" in gasoline than the theoretical ratio.

On the other hand, for maximum economy and least emissions, it is desirable to burn all of the fuel, in order to extract as much energy as possible with minimum residual. Because of the imperfect combustion conditions, additional air is required to insure that each molecule of fuel can be combined with the necessary oxygen. As a result, the actual air-fuel ratio for maximum economy tends to be somewhat "leaner" in gasoline than that calculated for chemically perfect combustion.

The best air-fuel ratio for any given operating condition varies from engine to engine due to differences in manifolding, combustion chamber design, valve timing, ignition timing, and other engine design factors. The optimum mixture can best be determined by operating an engine on a dynamometer where power, speed, and fuel consumption may be measured over a wide range of conditions.

Tests made at speeds throughout the engine's operating range reveal that the air-fuel ratio for maximum power remains nearly constant at all except low speeds (Fig.

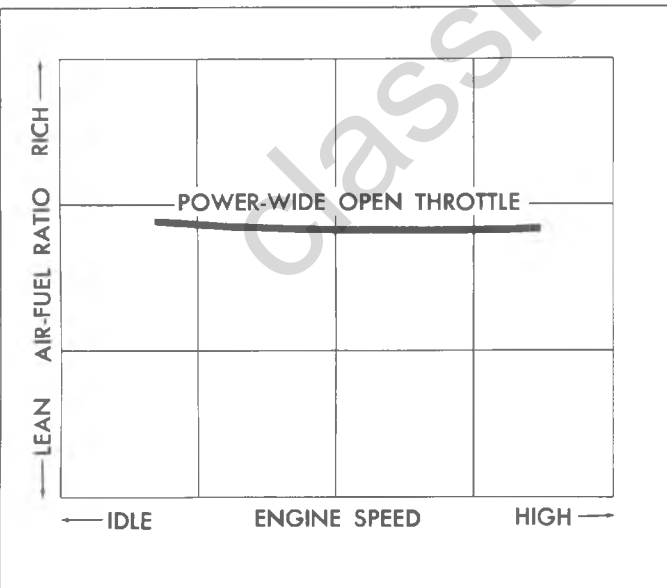

Fig. 11--Air-Fuel Flow--Full Throttle

11). Here, some slight enrichment is necessary due to the effect of exhaust-gas dilution in the cylinder and the poor mixing and distribution from the lower velocity air flow into the engine.

Similarly, the leaner air-fuel ratios for maximum economy at part throttle (Fig. 12) are found to be essentially equal throughout most of the operating range. Again, enrichment is necessary at low speeds and during idling; for the latter, the air-fuel ratio usually falls in the range from 11-to-1 to 12.5-to-1. Richer mixtures are also used at high operating speeds and loads, where more power is required.

It is usually desirable to operate the engine so that the best fuel mileage can be secured during normal cruising,

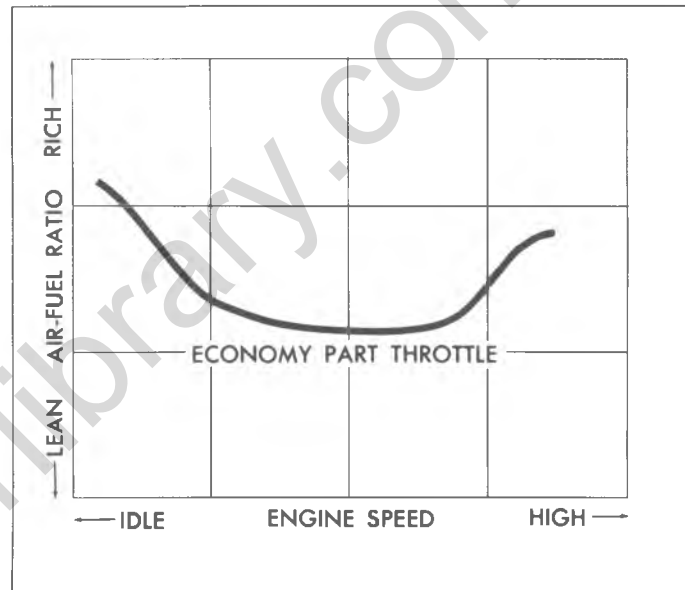

Fig. 12--Air-Fuel Flow--Idle, Part Throttle

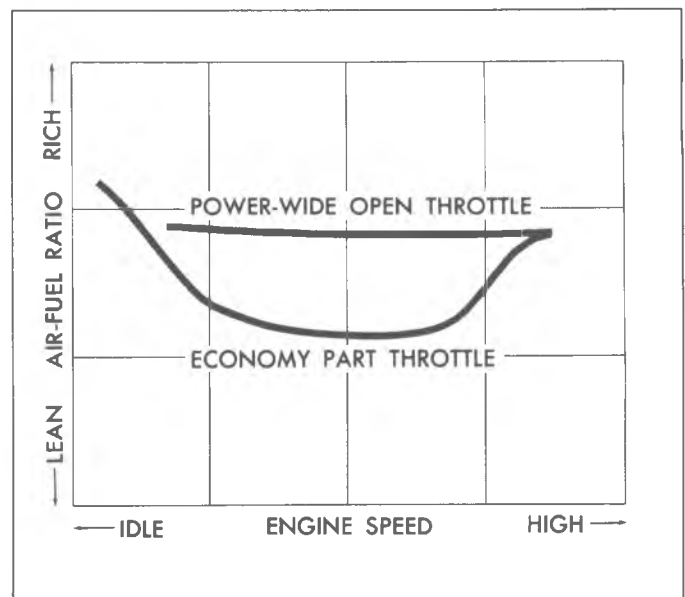

Fig. 13--Air-Fuel Flow--Complete Air

while maximum power should be available when the throttle is opened for acceleration or top speed (Fig. 13).

Through this point, we have covered the engine's general requirements insofar as the need for both a vaporized mixture and the proportions, or ratio, of the air-fuel vapor for efficient combustion. This leaves only one question which needs clarification before we end this discussion of air-fuel requirements, that is, "Why are richer fuel mixtures needed for cold starts "

## COLD STARTS

Recall for a moment that the cigarette lighter could be ignited easily indoors but after exposure to colder air, the lighter failed to light. It was concluded that the lighter failed to light because there was too little fuel vapor or actually the air-fuel ratio was too lean to burn.

Preheating to increase fuel vaporization to correct the air-fuel ratio is the answer in the case of the cigarette lighter but this would be impractical from a time and cost standpoint for automotive use.

We are all aware that a choke is used on carburetors to restrict the air flow and thereby enrich the fuel mixture. Because of this, many assume that a richer mixture is actually burned during cold engine operation but this is definitely not the case. Although the air-fuel ratio may vary fuel is always burned at a 15:1 ratio. While this may seem contrary to actual conditions, the key is the term "vaporize." Since only vaporized fuel burns and the vaporization rate is sharply reduced at lower temperatures, a rich fuel charge must be admitted so that the total resultant fuel vapor reaching the cylinders will be rich enough to create a combustible mixture.

The extra fuel (that which did not vaporize) is minimized, or in some engines is discharged from the port unburned as waste during the exhaust cycle and burned in the exhaust system. While this represents a considerable waste of fuel, it is necessary to provide combustible fuel mixtures until the engine is warmed up.

While the discussion of engine air-fuel requirements has been brief, the following points should be remembered:

- Only vaporized gasoline will burn
- Air-Fuel ratios are referenced in terms of weight
- Vaporization rates reduce as temperature declines
- Gasoline always burns at a 15-to-1 ratio; extra fuel is not burned but lost as waste.

## BASIC CARBURETOR SYSTEMS

The carburetor performs a comparatively simple job but it does so under such varied conditions that it is necessary to have several systems to alter its functions so that it can adjust to various situations. Most carburetors contain the following six basic systems:

- Float System
- Idle System
- Main Metering System

- Power System
- Pump System
- Choke System

## Float System

(Fig. 14)

Fuel in the carburetor float bowl must be maintained at a specified level for correct fuel metering under all driving conditions. The float system accomplishes this by using a float pontoon and attached leverage arm which exerts force against a needle valve, shutting off fuel flow when the specified level is reached in the carburetor bowl. Fuel enters the inlet and fills the carburetor bowl through the valve orifice (needle seat).

As the level in the bowl rises, the buoyant action of the float seats the needle valve. When fuel is being used from the bowl, the float drops sufficiently to allow the needle to unseat and fuel to enter past the needle to maintain the specified level in the float bowl.

The liquid level controlled by the float setting is an important part of the calibration of the carburetor. The effects of a low liquid level causes poor performance in the main metering system and could cause loss of power. High liquid level can result in premature main metering delivery and fuel spillage during normal car maneuvering, each of which causes excessive fuel consumption and an over-rich condition. The fuel level is controlled by a float and adjusted by bending a tab on the float arm. Accuracy of this adjustment may be measured by checking the physical relationship of the float to a particular area on the fuel bowl.

The float system is perhaps one of the most important

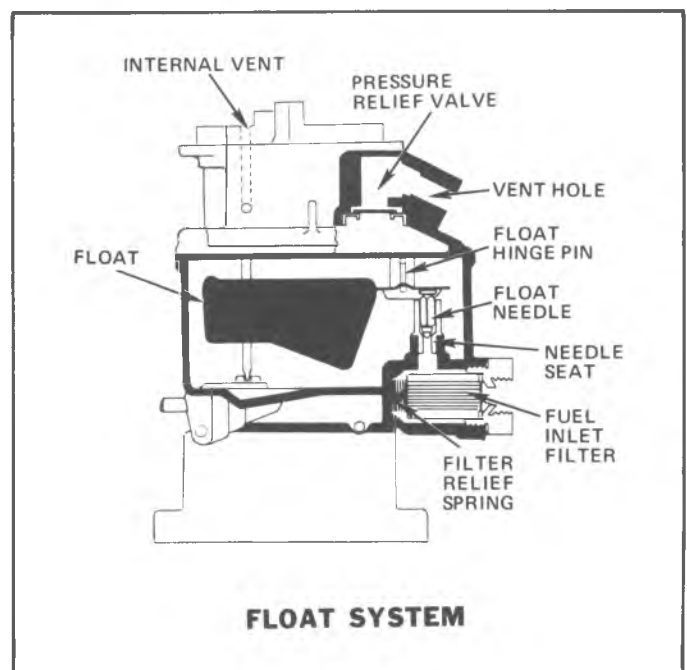

Fig. 14--Float System

## 6M-10 ENGINE FUEL

systems in the carburetor, as the correct operation of all other systems depends on the proper level of fuel in the float bowl.

### Idle System

(Fig. 15)

During engine idle and low speed operation, air flow through the carburetor is very slight due to the throttle blade being nearly closed and is insufficient to meter fuel properly from the main discharge nozzle. To offset this condition, the idle system is used to provide the proper mixture ratios required during engine idle and low speed operation. The idle system consists of an idle tube, idle passages, idle air bleeds, off-idle discharge ports, idle mixture adjusting needle and the idle mixture needle discharge port.

In the idle speed position, the throttle valve is slightly open, allowing a small amount of air to pass between the wall of the carburetor bore and the edge of the throttle valve. Since there is not enough air flow for venturi action, the fuel is made to flow by the application of manifold vacuum directly through the idle system to the fuel in the carburetor bowl.

The low pressure below the throttle valve (manifold vacuum) will cause the fuel to flow through the idle tube, into the idle passage, where it is mixed with air from the air bleed. This is the first stage of atomizing the fuel. The mixture continues down the passage, past the off-idle

ports. At this point these ports act as air bleeds to further break up the mixture. The mixture flows past the mixture screw into the carburetor bore and into the engine intake manifold. The mixture screw controls the idle mixture and is turned in to lean the mixture and out to richen it. Mixture screws are now locked after flow test at the manufacturing plant by means of limiter caps which attach over the mixture screws. These caps must not be tampered with in the field due to the effect on exhaust emissions.

As the throttle valve is opened, additional air flows through the carburetor. Since air flow is still insufficient to draw fuel from the main nozzle, the increased air flow results in excessively lean mixtures. To compensate for this problem off-idle ports are added to the carburetor (inset Fig. 15) just above the closed throttle position. When the throttle is opened during slow speed or off-idle operation (Fig. 15), the off-idle ports are exposed to manifold vacuum and begin discharging extra fuel mixture for off-idle requirements. Thus, the off-idle ports have a dual purpose. At idle they act as air bleeds but during the off-idle range they change to fuel mixture feeds.

Both the idle and off-idle ports are designed to provide a smooth transition between idling and cruising speeds of 25 to 40 mph for passenger cars, depending on carburetor design. At these speeds, the throttle opening and air flow are sufficient to permit the main metering system to begin to supply fuel.

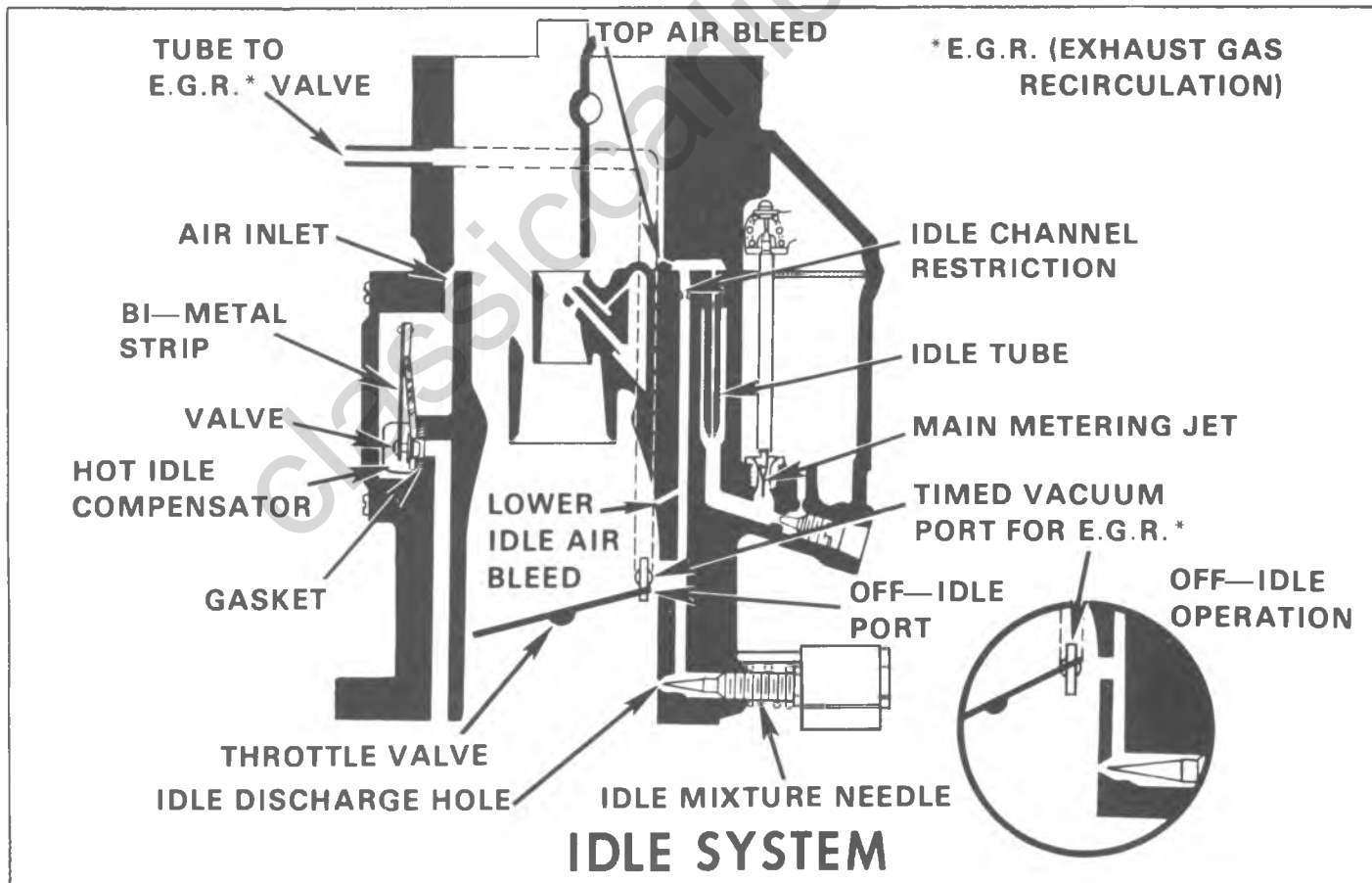

Fig. 15--Idle System (Monojet Shown)

The point at which fuel flow starts from the main nozzle is the transfer point (Fig. 16). This means that the carburetor is passing from idle to main metering system. The idle port discharge however, does not cease at this point but rather diminishes as main nozzle discharge increases. Thus, the two systems interact and produce a smooth fuel-air flow at all engine speeds.

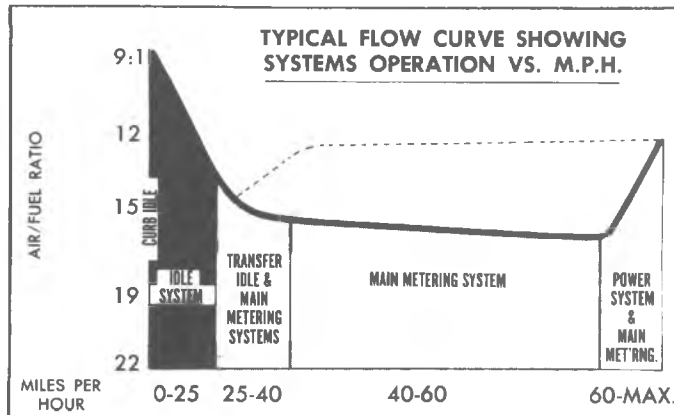

Fig. 16--Typical Systems Operation

## Main Metering System

(Fig. 17)

The main metering system controls the economy range

of the carburetor. It consists of a main jet, main well and main nozzle with air bleeds in it. The main jet is a very accurately machined orifice, which controls the fuel flow through the main well in which the nozzle is located. An air bleed in the main well and the air bleeds in the main nozzle keep the mixture constant throughout the operating range of the main metering system.

As the throttle valve is opened, air velocity through the venturi system increases which in turn decreases the pressure in the venturi at the main fuel nozzle. This action causes the fuel to pass through the main metering jet into the main well where it rises in the main well passage and idle pickup tube. As the fuel enters the nozzle, it is mixed with air through calibrated holes in the nozzle. Air is bled into the main well by the air bleeds. This air aids in breaking up the fuel for improved distribution. The mixture continues through the main discharge nozzle and enters the air stream at the boost venturi. At this point it is mixed with the incoming air and is carried past the throttle valve and into the manifold for distribution to the engine cylinders.

The main metering jet and the air bleeds are pre-calibrated to maintain the desired air-fuel ratios throughout the main metering range. Therefore, no adjustments are necessary in the main metering system.

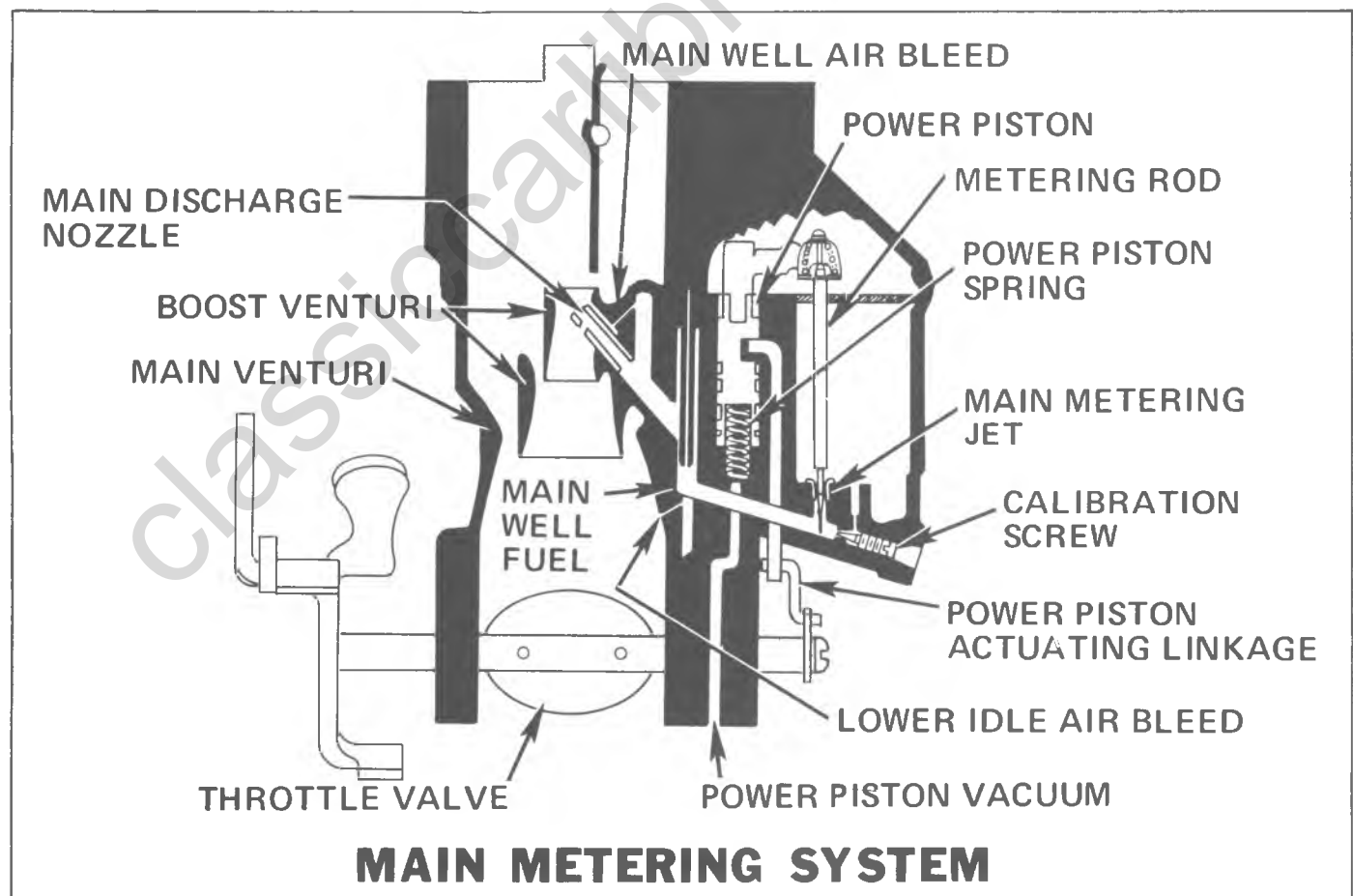

Fig. 17--Main Metering System (Monojet Shown)

## Power System

(Fig. 18)

As discussed previously, richer fuel mixtures are needed for high speed operation since maximum engine power requires the use of all available air for combustion. The power system is used to supplement the main metering system and provide the power enrichment according to the amount of throttle opening and engine load.

The power system consists of: a power valve, power piston and spring, and power restriction. The power valve controls a fuel passage which bypasses the main metering jet from the bowl to the main well. The power piston is located above the valve and determines when the valve will open.

The power piston is spring loaded and normally held in the closed position by high manifold vacuum conditions.

Under conditions of power, manifold vacuum will be low which means vacuum will decrease on top of the piston allowing the spring to corce the power piston down, opening the valve to increase the fuel flow to the main nozzle. This has the same effect as enlarging the main jet. A calibrated power restriction is used in the passage between the power valve and the main well to control the amount of enrichment.

While this system is constantly operative only at speeds approaching wide open throttle and above, sudden throttle openings at slow and mid-range speeds will cause momentary opening of the power valve, due to resultant manifold vacuum decreases. Power valve springs generally are calibrated to allow opening to begin at 8" to 9" average and full opening when manifold vacuum falls below 4" to 6" average. There is no adjustment required for the power system.

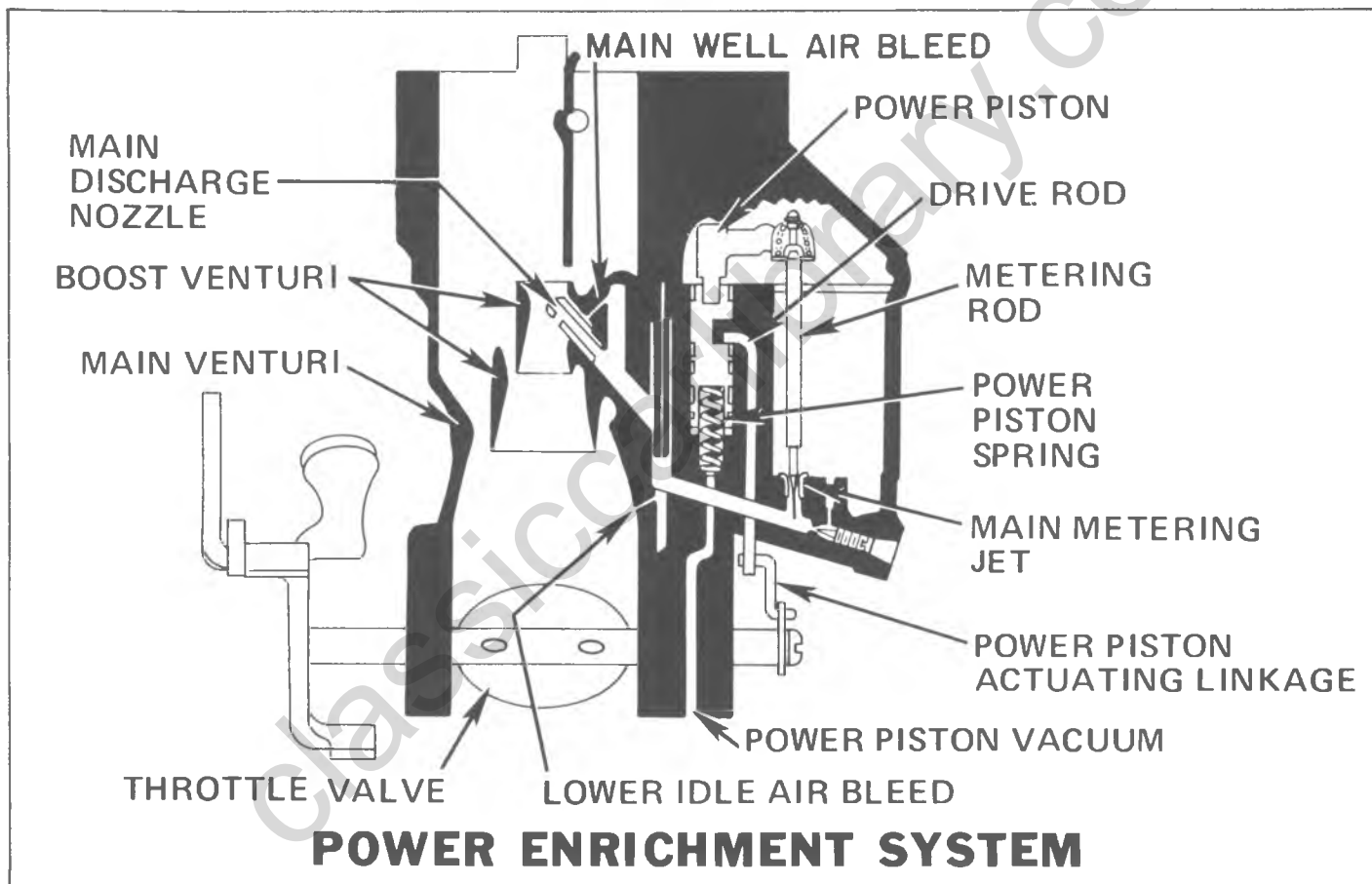

Fig. 18--Power System (Monojet Shown)

## Pump System

(Fig. 19)

When the throttle is opened rapidly, the air flow and manifold vacuum change almost instantly. Because of the great difference in weight between air and fuel, any sudden change in throttle opening results in an immediate increase in air intake but the fuel, having greater weight tends to lag behind. The result of this is momentary leanness. The accelerator pump provides the

extra fuel necessary to overcome this leanness and give smooth operation during transient operations. This is accomplished by discharging extra fuel into the venturi air stream whenever the throttle valve is opened. The pump system utilizes a pump plunger that is linked to the throttle lever by mechanical linkage.

When the pump plunger moves upward in the pump well, as happens during throttle closing, fuel from the float bowl enters the pump well through a slot in the top of the pump well, or through an inlet check valve in

earlier design carburetors. It flows past the pump cup seal into the bottom of the pump well. The pump plunger is the floating type of which the cup moves up and down on the pump plunger head. Some models may use the fixed cup, ball vapor vent design. When the pump plunger is moved upward, the flat on the top of the cup unseats from the flat on the plunger head and allows free movement of fuel through the inside of the cup into the bottom of the pump well. During a shut down soak period this also vents any vapors which may be in the bottom of the pump well so that a solid charge of fuel can be maintained in the fuel well beneath the plunger head. At the same time, the discharge check

valve seats to prevent air from leaking into the discharge passage. When the throttle valves are opened, the connecting linkage forces the pump plunger downward. The pump cup seats instantly and fuel is forced through the pump discharge passage, where it unseats the pump discharge check valve and passes on through the passage to the pump jets where it sprays into the venturi area of each bore.

The accelerator pump system is an accessory device which has no function other than momentary operation at the time of throttle position changes. The pump is purely mechanical and not affected by air flow.

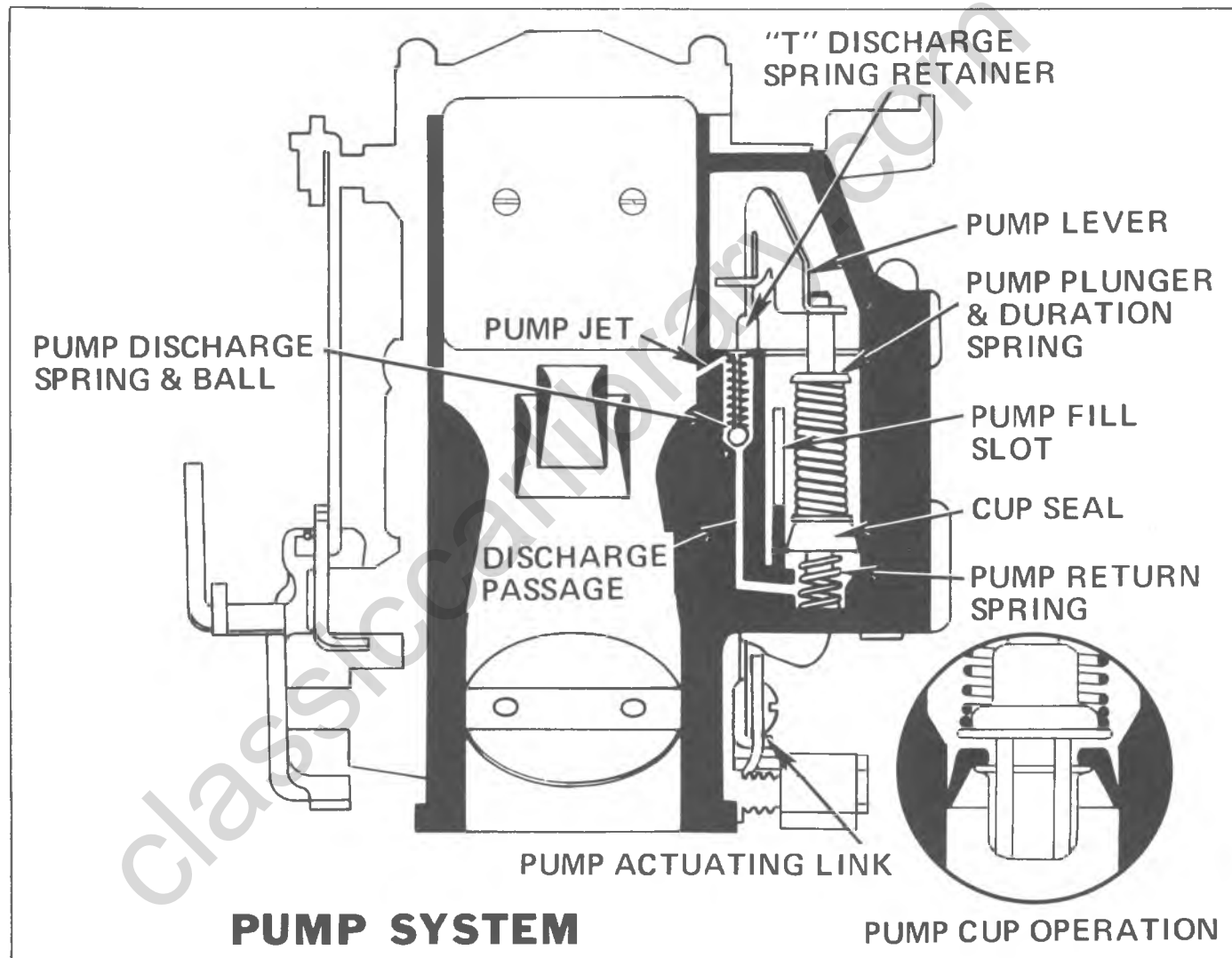

Fig. 19--Pump System (Monojet Shown)

### Choke System

(Fig. 20)

The necessary requirements for good fuel vaporization are missing or are inadequate when starting a cold engine. To overcome this condition, plus condensation of the fuel on the cold manifold, it is necessary to meter extremely rich mixtures from the carburetor (2:1 to 1:1

air-fuel ratios) in order to provide sufficient combustible mixtures to the cylinders for quick starting. This enrichment is obtained by the addition of a choke valve in the air horn above the main metering system; starting fuel to flow through these systems.

The choke system consists of a choke valve located in the primary air horn, a vacuum break diaphragm unit, fast idle cam, choke linkage and a thermostatic coil which is

## 6M-14 ENGINE FUEL

located on the engine manifold. The coil is connected to the choke valve by a rod. The choke operation is controlled by a combination of intake manifold vacuum, the off-set choke valve, thermostatic coil characteristics, atmospheric temperature, and exhaust manifold heat.

The remote thermostatic coil located on the engine manifold is calibrated to hold the choke valve closed when starting a cold engine, air velocity against the off-set choke valve causes the valve to open slightly, against the torque of the thermostatic coil. When the engine is started, manifold vacuum applied to the vacuum diaphragm unit mounted on the carburetor air horn will open the choke valve to a point where the engine will operate without loading (rich) or stalling (lean). The choke valve will remain in this position until the engine begins to warm up.

Through application of exhaust manifold heat, the thermostatic coil relaxes gradually until the choke valve is fully open. Opening of the choke valve is controlled by air flow through the carburetor air horn, past the off-set choke valve and manifold heat acting upon the thermostatic coil. As the engine is accelerated during

warm-up, the corresponding drop in manifold vacuum and low air flow against the off-set choke valve, allows the thermostatic coil to momentarily close the choke, providing a richer mixture.

During warm-up it is necessary to provide a faster idle to prevent engine stalling. This is accomplished by a fast idle cam which is connected by a rod to a lever on the choke shaft. The idle screw on the throttle lever contacts graduated steps on the fast idle cam to provide a faster idle than normal, to prevent engine stalling during the warm-up period. When the engine is fully warm and the choke valve is wide open, the fast idle cam rotates so that the idle screw rests on the low step on the fast idle cam where normal curb idle is obtained. Some carburetors have separate fast and curb idle air adjustment screws. If the engine becomes flooded during the starting period, the choke valve can be partially opened manually to allow increased air flow through the carburetor. This is accomplished by depressing the accelerator pedal to the floor. The unloader projection on the throttle lever contacts the edge of the fast idle cam and, in turn, partially opens the choke valve. The extra air leans out the fuel mixture enough so the engine will start.

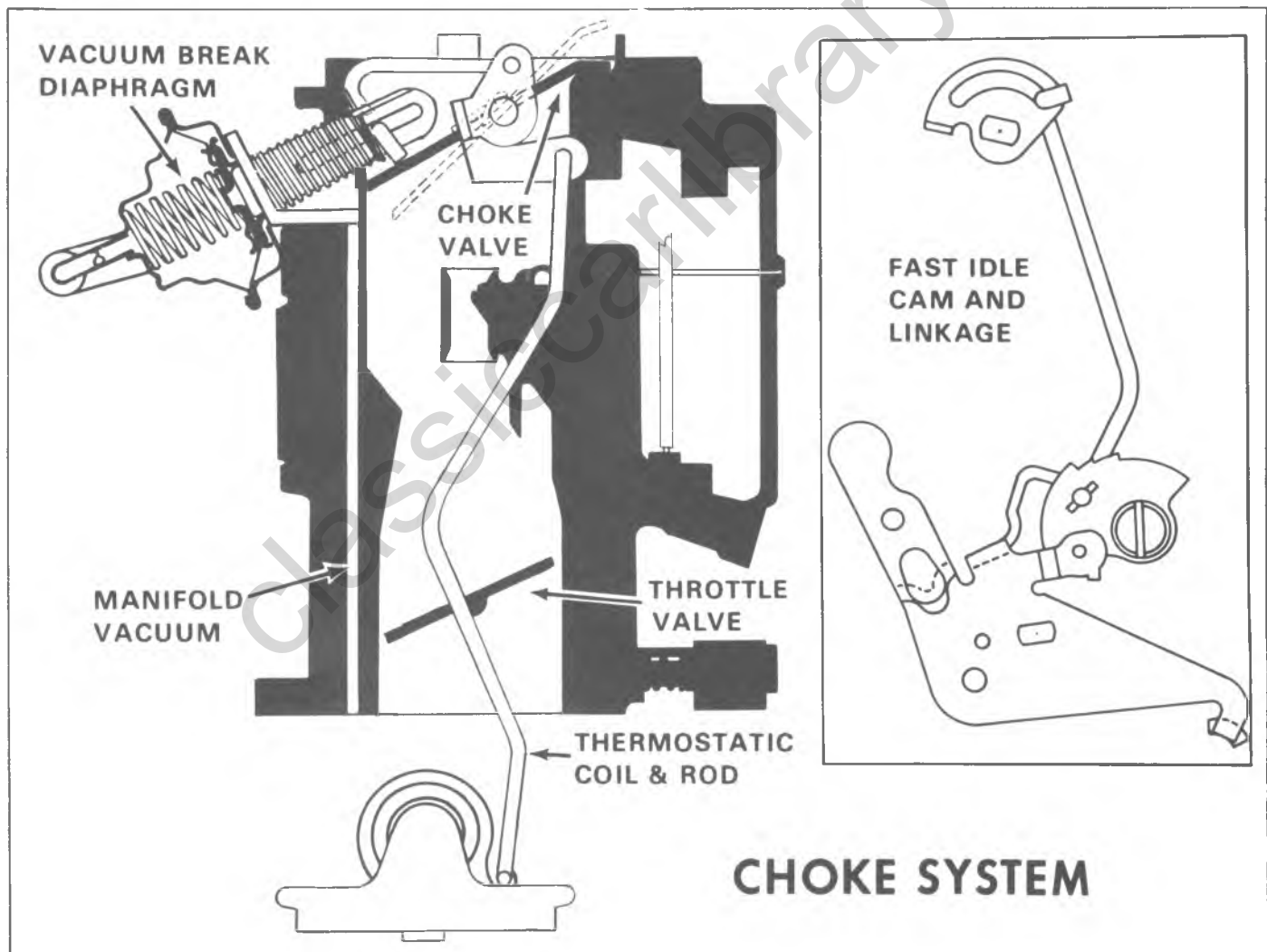

Fig. 20--Choke System (Monojet Shown)



## MAINTENANCE AND ADJUSTMENTS

**NOTE:** Also refer to the "Emission Control Systems" Booklet for required maintenance and warranty information.

**Timing Points (Dwell), Idle Speed** - These adjustments must be performed accurately, following the specifications shown on the label under the hood. Adjustments must be made with test equipment known to be accurate.

Proper functioning of the carburetor is particularly essential to control of emissions. Correct mixtures for emission compliance and idle quality have been preset. Plastic idle mixture limiters have been installed on the idle mixture screws to preclude unauthorized adjustment. These idle limiters are not to be removed unless made necessary by some major carburetor repair or replacement which affects the idle screw adjustment.

**CHOKE**-Choke mechanism should be checked for free operation. A binding condition may have developed from petroleum gum formation on the choke shaft or from damage. Choke shafts can usually be cleaned without disassembly by using United Delco X-66 Carburetor and Combustion Chamber Conditioner or equivalent.

**BOLTS, CARBURETOR TO MANIFOLD**-Carburetor attaching bolts and/or nuts should be carefully adjusted to correct torque to compensate for compression of gasket at first 4 months or 6,000 miles of vehicle operation only.

**FILTER-CARBURETOR AND/OR FUEL PUMP**-A clogged carburetor or fuel pump filter may restrict fuel flow or bypass foreign material into carburetor depending upon type used. Replace clogged filters. Also replace filters each 12,000 miles or 12 months, whichever occurs first.

**VACUUM ADVANCE SOLENOID, AND HOSES**-The vacuum portion of this valve should be checked, with the transmission in neutral, by using a vacuum gauge attached to the valve (or solenoid) distributor connector. With the engine at fast idle, the vacuum gauge should read zero. The electrical portion of the solenoid or valve may be checked by applying 12 volts across its electrical terminals, which should result in a vacuum reading on the gauge — a vacuum reading should be obtained only while the solenoid or valve is not energized. An inoperative or leaking solenoid or valve should be replaced.

All hoses and wires should be carefully inspected for correct routing and to make certain that they are intact.

**IDLE STOP SOLENOID**-The idle stop solenoid should be checked to assure that it permits the throttle plate to close further when the ignition switch is turned "off." An inoperative solenoid should be replaced.

### PRELIMINARY CHECKS (ALL CARBURETORS)

1. Thoroughly warm-up engine. If the engine is cold, allow to run for at least 15 minutes.
2. Inspect torque of carburetor to intake manifold bolts and intake manifold to cylinder head bolts to exclude the possibility of air leaks.
3. Inspect manifold heat control valve (if used) for freedom of action and correct spring tension.
4. Check and adjust choke as required, using procedures specified in this section.
5. Adjust idle speed and idle mixture as outlined in this section and in Section 6, "Engine Tune-up".

### EXTERNAL ADJUSTMENTS (ALL CARBURETORS)

#### INDEX

Adjustments.....	6M-15	Automatic Choke Coil Assemblies.....	6M-26
Removal.....	6M-24	Choke Coil Replacement.....	6M-26
Test Before Installation.....	6M-25	Additional External Settings and Adjustments.....	6M-26
Installation.....	6M-25	Throttle Linkage Adjustment.....	6M-27
Fuel Filter Maintenance.....	6M-26		

### ROCHESTER MV, 2GV AND 4MV ADJUSTMENTS

#### IDLE MIXTURE ADJUSTMENT PROCEDURE

Idle mixture screws have been preset at the factory and capped. Do not remove caps unless adjustment is required.

Before suspecting the carburetor as the cause of poor engine performance or rough idle, check ignition system including distributor, set ignition timing, check PCV system and compression pressures. Also, check all vacuum hoses and connections for leaks and check

carburetor attachment bolt torques.

The Federal Government has defined Light and Heavy Duty Vehicles for emission purposes as follows:

Light Duty Vehicles:

6000 lb. GVW or less or designed for transportation of persons and having a capacity of 12 or less.

C, K, P 10 all

C, K20 Suburban

## 6M-16 ENGINE FUEL

G10, 20 All

G30 Sportvan

Heavy Duty Vehicles:

More than 6000 lb. GVW or designed for transportation of persons and having a capacity of greater than 12.

C20, 30 All (exc. Suburban)

K20 All (exc. Suburban)

G30 Van

P20, 30 All

At 24,000 mile intervals for light duty vehicles and 12,000 mile intervals for heavy duty vehicles, or in case of major carburetor overhaul, or when poor idle quality exists after performing the checks in the previous paragraph, idle mixture may be adjusted. To properly set idle mixture to achieve the smoothest idle while maintaining emission levels within the standards prescribed by Federal law, the following procedure must be followed:

1. Refer to Specifications for idle speed settings.
2. Set parking brake and block drive wheels.

3. Disconnect fuel tank vent hose from vapor canister, (All Light Duty and on Heavy Duty if equipped) and disconnect and plug distributor vacuum hose at vacuum advance unit.
4. With engine at normal operating temperature (not hot), air conditioning off, and air cleaner installed, place transmission selector in Drive for light duty and in Neutral for heavy duty (automatic transmission) or neutral (manual transmission).
5. Break off tab on mixture cap using a needle nose pliers.
6. Adjust idle RPM to the higher of the two idle speeds specified, with idle stop solenoid energized and extended (example 650/600). If not equipped with idle stop solenoid, set idle speed with speed screw.
7. Equally richen (turn out) mixture screws until maximum idle speed is achieved. Reset speed if necessary to the higher specified idle speed.
8. Equally lean (turn in) mixture screws until the lower specified idle speed is achieved (example 650/600).
9. Connect fuel tank vent hose and distributor vacuum advance hose.

Classiccarlibrary.com

## IDLE MIXTURE ADJUSTMENT SPECIFICATIONS LIGHT DUTY EMISSION VEHICLES

### GM 102 250 cu. in. - Federal

Exhaust Emission Control System  
Timing (°BTC @ RPM)  
Solenoid Adj. (RPM)  
Lean Drop Idle Mixture (RPM)

### Transmission

<u>Automatic</u>	<u>Manual</u>
CCS-EGR	AIR-EGR
8° @ 600	8° @ 850
600 (DR)	850 (N)
650/600 (DR)	950/850 (N)

### GM 102 250 cu. in. - California

AIR-EGR Exhaust Emission Control  
Timing (°BTC @ RPM)  
Solenoid Adj. (RPM)  
Lean Drop Idle Mixture (RPM)

### Transmission

<u>Automatic</u>	<u>Manual</u>
N/A	8° @ 850
	850 (N)
	950/850 (N)

### GM 104-2 350 cu. in. 2bbl - Federal

AIR-EGR Exhaust Emission Control  
Timing (°BTC @ RPM)  
Solenoid Screw (RPM)  
Lean Drop Idle Mixture (RPM)

### Transmission

<u>Automatic</u>	<u>Manual</u>
8° @ 600	4° @ 900
600 (DR)	900 (N)
650/600 (DR)	1000/900 (N)

### GM 104-4 350 cu. in. 4bbl Fed. (Exc. C-K 10 & 20 Suburban and G20 & 30 Sportvans)

	<u>Auto. Exc. Versavan (COPO)</u>	<u>Auto. Versavan (COPO)</u>	<u>Manual</u>
Exhaust Emission Control System	CCS-EGR	AIR-EGR	AIR-EGR
Timing (°BTC @ RPM)	8° @ 600	8° @ 600	8° @ 900
Solenoid Screw (RPM)	600 (DR)	600 (DR)	900 (N)
Lean Drop Idle Mixture (RPM)	650/600 (DR)	630/600 (DR)	950/900 (N)

### GM 104-4 350 cu. in. 4bbl Fed. C-K 10 & 20 Suburbans and G20 & 30 Sportvans

	<u>Auto. Manual</u>	<u>Exc. Suburban</u>	<u>Manual Suburban</u>
AIR-EGR Exhaust Emission Control	Auto.	Exc. Suburban	Suburban
Timing (°BTC @ RPM)	12° @ 600	8° @ 900	6° @ 900
Solenoid Screw (RPM)	600 (DR)	900 (N)	900 (N)
Lean Drop Idle Mixture (RPM)	630/600 (DR)	950/900 (N)	950/900 (N)

### GM 104-4 350 cu. in. 4bbl Cal.

	<u>Auto. Exc. Suburban</u>	<u>Auto. Suburban</u>	<u>Manual</u>
AIR-EGR Exhaust Emission Control	Suburban	Suburban	Manual
Timing (°BTC @ RPM)	8° @ 600	6° @ 600	4° @ 900
Solenoid Screw (RPM)	600 (DR)	600 (DR)	900 (N)
Lean Drop Idle Mixture (RPM)	630/600 (DR)	630/600 (DR)	950/900 (N)

### GM 105 454 cu. in. - Federal

AIR-EGR Exhaust Emission Control  
Timing (°BTC @ RPM)  
Solenoid Screw (RPM)  
Lean Drop Idle Mixture (RPM)

### Transmission

<u>Automatic</u>	<u>Manual</u>
10° @ 600	10° @ 800
600 (DR)	800 (N)
630/600 (DR)	850/800 (N)

### GM 105 454 cu. in. - California

AIR-EGR Exhaust Emission Control  
Timing (°BTC @ RPM)  
Solenoid Screw (RPM)  
Lean Drop Idle Mixture (RPM)

### Transmission

<u>Automatic</u>	<u>Manual</u>
10° @ 600	10° @ 800
600 (DR)	800 (N)
630/600 (DR)	850/800 (N)

HEAVY DUTY EMISSION VEHICLES

FAMILY	ENGINE (CID)	IDLE SPEED (RPM)	TIMING (°BTC)	LEAN DROP SETTINGS (RPM)
GM111	250	600	6	700/600
GM112	292	600	8	700/600
GM113	350/4bb1	600	4	750/600
GM115	454	700	8	800/700

ALTERNATE PROCEDURE IDLE MIXTURE ADJUSTMENT

TO BE USED ONLY IF RELIABLE CO METER IS AVAILABLE

NOTE: CO Meter must be capable of low level, accurate readings. Meters with an accuracy of ±2% of full scale reading and scale divisions of 0.2% CO, or less, will be suitable.

Idle mixture screws have been preset at the factory and capped. Do not remove caps.

Before suspecting the carburetor as the cause of poor engine performance or rough idle, check ignition system including distributor, set ignition timing, check PCV system, and compression pressures. Also, check all vacuum hoses and connections for leaks and check carburetor attachment bolt torques.

at 24,000 mile intervals for light duty vehicles and 12,000 mile intervals for heavy duty vehicles or in the case of high idle CO, major carburetor overhaul, or when poor idle quality exists after performing the checks in the previous paragraph, idle mixture may be adjusted. To properly set idle mixture to achieve the smoothest idle while maintaining emission levels within the standards prescribed by Federal Law, the following procedure MUST be followed:

1. Refer to Specifications for idle CO values.
2. Set parking brake and block drive wheels.
3. Disconnect fuel tank vent hose from vapor canister (all light duty and on heavy duty if equipped) and

disconnect and plug distributor vacuum hose at vacuum advance unit.

4. With engine at normal operating temperature (not hot), air conditioning off and air cleaner installed, place transmission selector in Drive for light duty vehicles and Neutral for heavy duty vehicles (automatic transmission) or Neutral (manual transmission).
5. Connect CO meter to exhaust system tailpipe.
6. Set curb idle speed to specified RPM with idle stop solenoid energized and extended. (If not equipped with idle stop solenoid, set idle speed with speed screw).
7. Record idle CO. If idle CO exceeds value shown in Specifications, proceed as follows. If idle CO is within limits and engine idles smoothly, no further adjustment is required.
8. Turn each idle mixture cap (clockwise) in equal amounts until idle CO is at or below percent shown in Specifications. DO NOT REMOVE CAPS. Reset idle speed if necessary, with air cleaner in place.
9. Connect fuel tank vent hose and distributor vacuum advance hose.

IDLE CO ADJUSTMENT SPECIFICATIONS

NOTE: Idle Speed and Timing Adjustment Specifications are the same for both lean drop and idle CO settings.

LIGHT DUTY EMISSION VEHICLES

	Max. Acceptable CO Level (%)	If Over Max. Acceptable Level Reset to (% or Less)
GM 102 (250 cu. in.)	.3	.3 or below
GM 104-2 (350 cu. in.)	.5	.5 or below
GM 104-4 (350 cu. in.)	.5	.5 or below
GM 105 (454 cu. in.)	.5	.5 or below

## HEAVY DUTY EMISSION VEHICLES

Engine Family	Max. Acceptable	If Over Max.
	CO Level (%) @ Level	Acceptable Level Reset to (% or Less)
GM 111 (250 cu. in.)	2.0	2.0
GM 112 (292 cu. in.)	0.3	0.3
GM 113 (350 cu. in. 4bb1)	0.5	0.5
GM 115 (454 cu. in.)	0.5	0.5

**FAST IDLE ADJUSTMENTS (Figs. 1C, 2C and 3C) ROCHESTER MV AND 4MV**

NOTE: The fast idle adjustment must be set with transmission in "Neutral."

1. Position fast idle lever on high step of fast idle cam.
2. Be sure choke is properly adjusted and in wide open position - engine warm.
3. Set fast idle to specified rpm as follows:

NOTE: Manual Transmission: Disconnect vacuum advance.

- a. Adjust fast idle screw on Rochester 4MV (Fig. 2C).
- b. Bend fast idle tang on throttle lever as required on Rochester MV to specified speed (Fig. 1C).

**FAST IDLE ADJUSTMENT-ALL 2 BBL.**

NOTE: The two barrel carburetors are preset to the approximate fast idle RPM noted in specifications, listed under "Fast Idle (Running) RPM adjustment", when low step idle is set. (Also note Low Idle RPM in specifications).

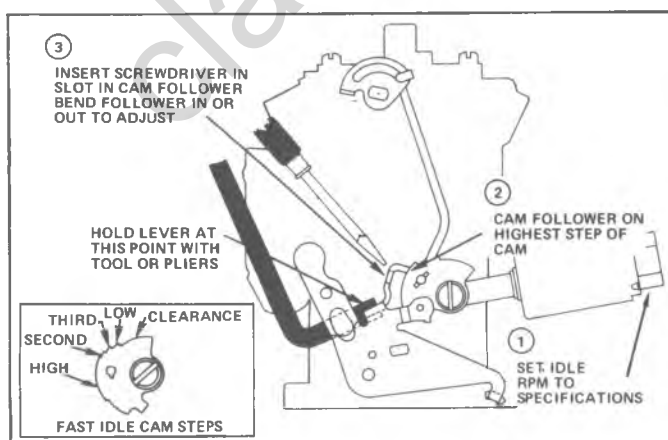

Fig. 1C--Fast Idle Adjustment (Rochester MV)

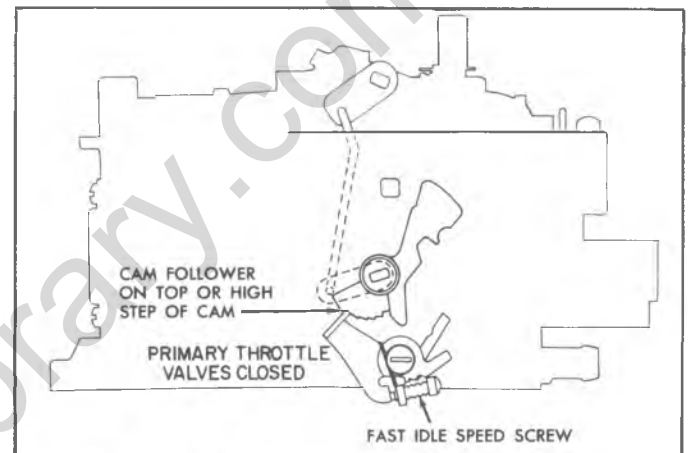

Fig. 2C--Fast Idle Adjustment (Rochester 4MV)

**CHOKE ROD (FAST IDLE CAM) ADJUSTMENTS MV (Fig. 4C)**

NOTE: Make sure that the fast idle adjustment is made previous to choke rod adjustment.

Automatic choke models with steps on fast idle cam. With fast idle adjustment made:

1. Place fast idle cam follower on second step of the

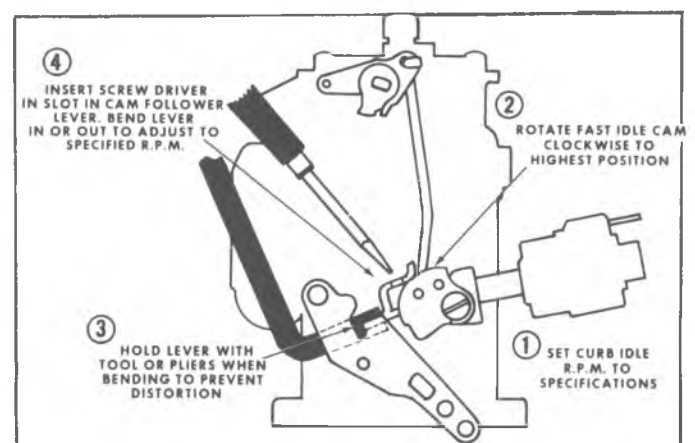

Fig. 3C--Fast Idle Adjustment (Manual Choke)

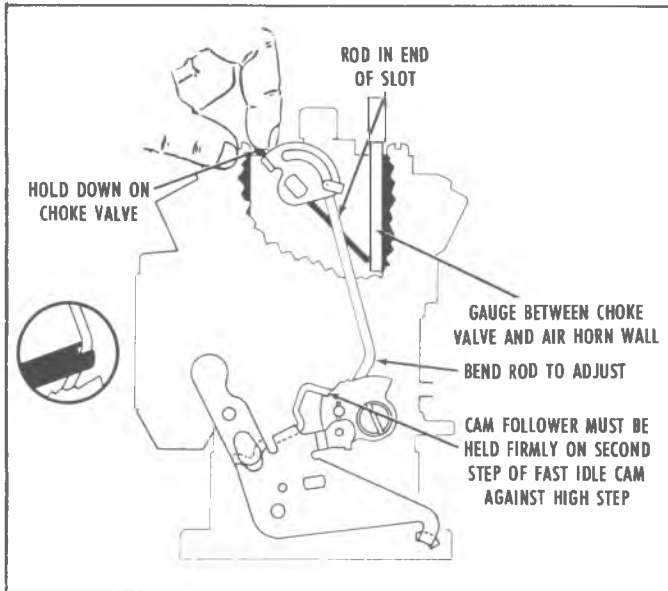

Fig. 4C--Choke Rod (Fast Idle Cam) Adjustment (MV)

fast idle cam and hold firmly against the rise to the high step.

2. Rotate choke valve toward direction of closed choke by applying force to choke coil lever.
3. Bend choke rod at point shown to give specified opening between the lower edge of choke valve (at center of valve) and inside air horn wall.

**2GV (Fig. 5C)**

Turn stop screw in until it just contacts bottom step of fast idle cam. Then turn screw in one full turn. Place idle screw on second step of fast idle cam against shoulder of high step. With screw in this position, hold choke valve toward closed position with a rubber band and check clearance between upper edge of choke valve and air horn wall. Adjust to specified dimension by bending tang on choke lever and collar assembly.

**4MV (Fig. 6C)**

With the cam follower on second step of fast idle cam

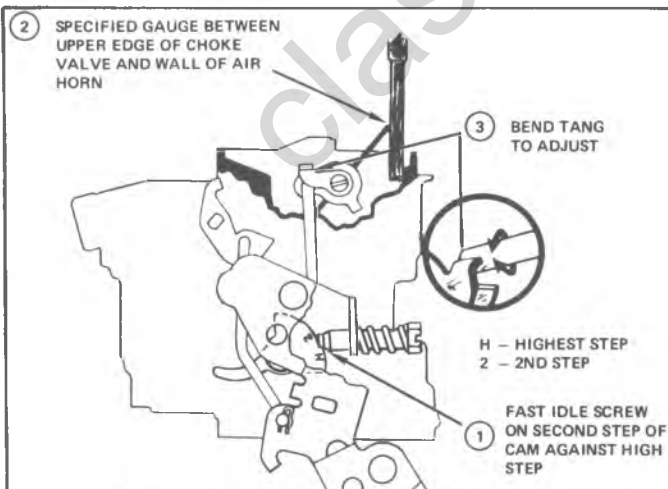

Fig. 5C--Choke Rod (Fast Idle Cam) Adjustment (2GV)

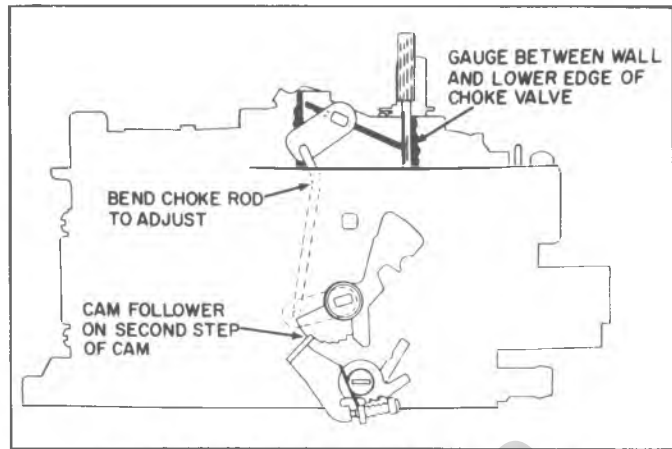

Fig. 6C--Choke Rod (Fast Idle Cam) Adjustment (4MV)

and against the high step, rotate the choke valve toward the closed position by turning the external choke lever counterclockwise. Dimension between the lower edge of choke valve, at choke lever end, should be as specified. Bend choke rod to adjust (Fig. 6C).

**CHOKE VACUUM BREAK ADJUSTMENTS MV (Fig. 7C)**

The following procedure for adjusting the vacuum break diaphragm unit is used to insure correct initial choke valve opening after engine starting:

1. Remove air cleaner assembly from vehicle.
2. Using an outside vacuum source, apply vacuum to the vacuum break diaphragm until the plunger is fully seated.
3. With the vacuum break diaphragm in the fully seated position, push the choke valve toward the closed position.

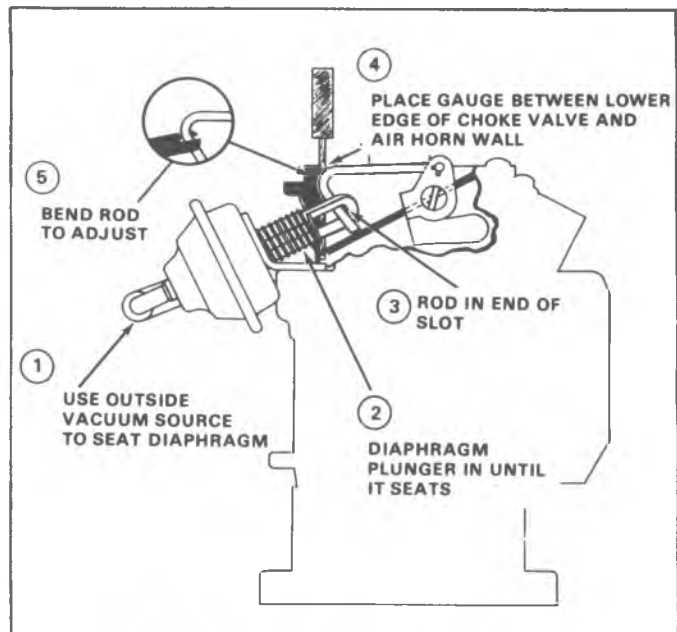

Fig. 7C--Vacuum Break Adjustment (MV)

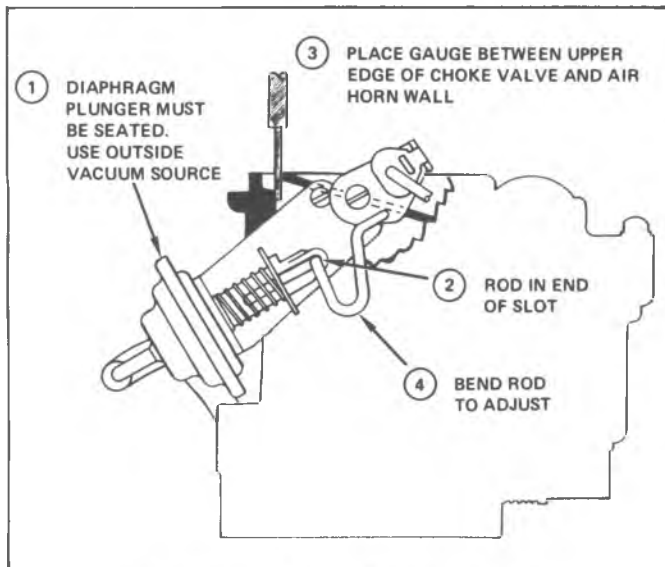

Fig. 8C--Vacuum Break Adjustment (2GV)

4. With the choke valve held in this position, place specified gauge between the lower edge of the choke valve and air horn wall.
5. Dimension should be as specified; if not, bend the vacuum break rod at point shown, to adjust.

### 2GV (Fig. 8C)

Refer to Figure 8C and follow steps under MV.

### 4MV (Fig. 9C)

1. Seat choke vacuum break diaphragm using outside vacuum source.
2. Open throttle valve slightly so cam follower will clear steps of fast idle cam. Then rotate vacuum break lever counterclockwise (towards direction of closed choke). A rubber band may be used to hold

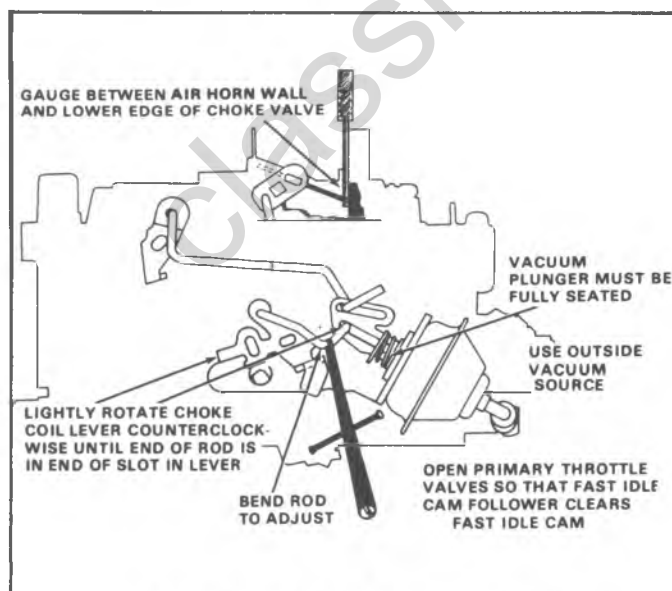

Fig. 9C--Vacuum Break Adjustment (4MV)

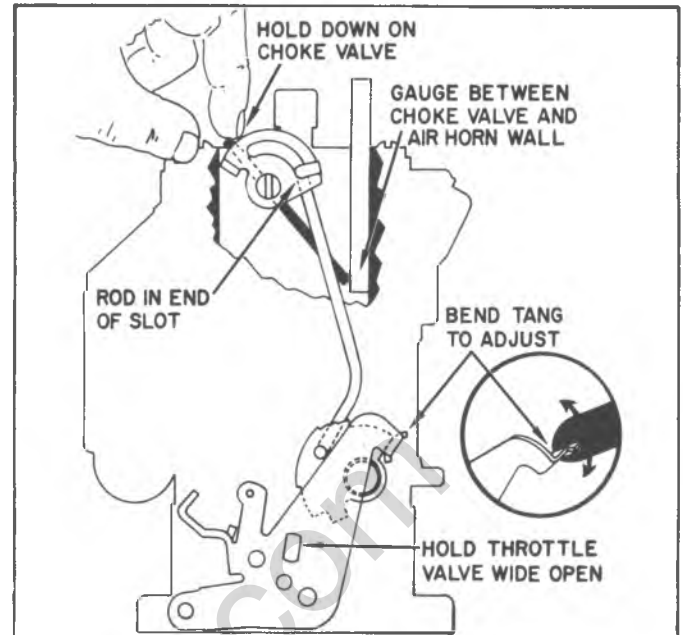

Fig. 10C--Unloader Adjustment (MV)

in place. The end of vacuum break rod should also be in outer end of slot in vacuum break diaphragm plunger.

3. Measure the distance between lower edge of choke valve and inside air horn wall.
4. To adjust to specified dimension, bend vacuum break link at point shown.

## CHOKE UNLOADER ADJUSTMENT

### MV (Fig. 10C)

1. Hold choke valve in closed position by applying a light force to the choke operating lever.
2. Rotate throttle lever to wide open throttle valve position.
3. Bend unloader tang on throttle lever to obtain specified dimension between lower edge of choke plate (at center) and air horn wall.

### 2GV (Fig. 11C)

With the throttle valves held wide open and the choke valve held toward the closed position with a rubber band, bend the unloader tang on the throttle lever to obtain specified clearance between the upper edge of the choke valve and air horn wall.

## CHOKE COIL ROD ADJUSTMENT

### MV (Fig. 12C)

1. Disconnect thermostatic coil rod from upper choke lever and hold choke valve completely closed.
2. With thermostatic coil rod disconnected, push downward on rod to end of travel.
3. With rod held in this position, the top of rod should

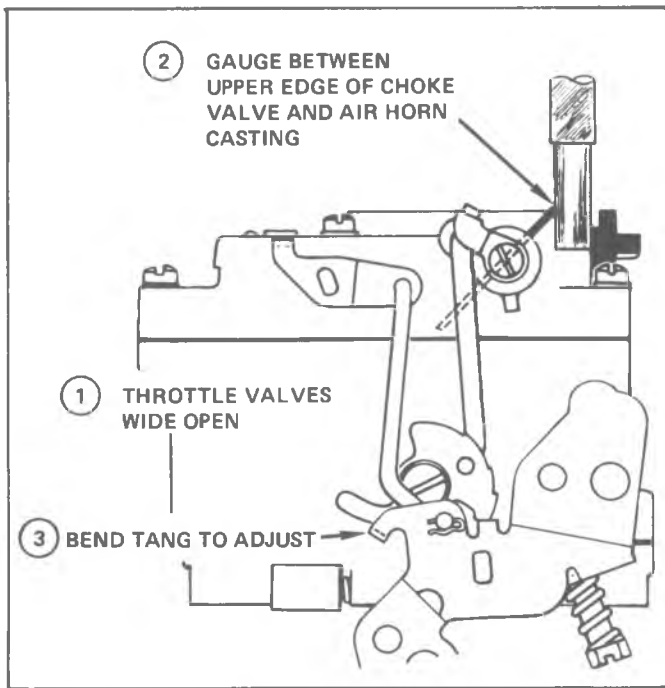

Fig. 11C-Choke Unloader (2GV)

be even with bottom of hole in choke lever.

- To adjust, bend rod at point shown.

### 2GV (Fig. 13C)

- Hold choke valve completely open.
- With the thermostatic coil rod disconnected from upper lever, push downward on rod to end of travel.
- With the rod in the fully downward position, bottom of rod should be even with the bottom of slotted hole in lever as shown.
- To adjust, bend lever at point shown with screwdriver end.

### 4MV (Fig. 14C)

- Hold choke valve completely closed by rotating choke coil lever counterclockwise.
- With the thermostatic coil rod disconnected, with cover removed, push downward on coil rod so that the rod contacts bracket surface.
- The coil rod must fit in choke lever notch, as shown.
- Bend choke coil rod at point shown to adjust.
- Install choke coil spring cover.
- Insert coil rod into choke coil lever slot and install retaining clip.
- Make sure that the choke valve operates freely and coil rod does not bind on choke cover from the full open to full closed position.

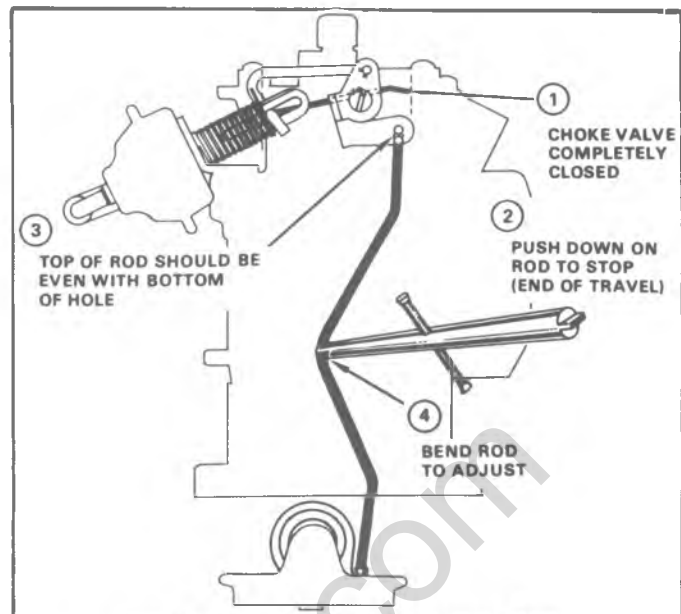

Fig. 12C-Choke Coil Rod Adjustment (MV)

### AIR VALVE DASHPOT ADJUSTMENT 4MV (Fig. 15C)

- Completely seat choke vacuum break diaphragm using an outside vacuum source.
- With choke diaphragm seated and air valve fully closed, measure the distance between the end of slot in vacuum break plunger lever and air valve.
- Adjust to specifications by bending rod as shown.

### ACCELERATOR PUMP ROD ADJUSTMENT 2GV (Fig. 16C)

Back out idle stop screw and completely close throttle valves in bore. Place gauge on top of air horn ring. Bend the pump rod at lower angle to obtain specified dimension to top of pump rod.

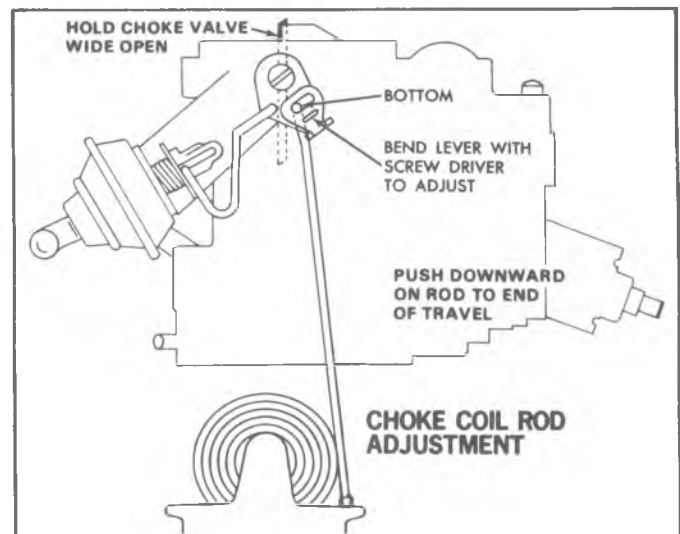

Fig. 13C-Choke Coil Rod Adjustment (2GV)



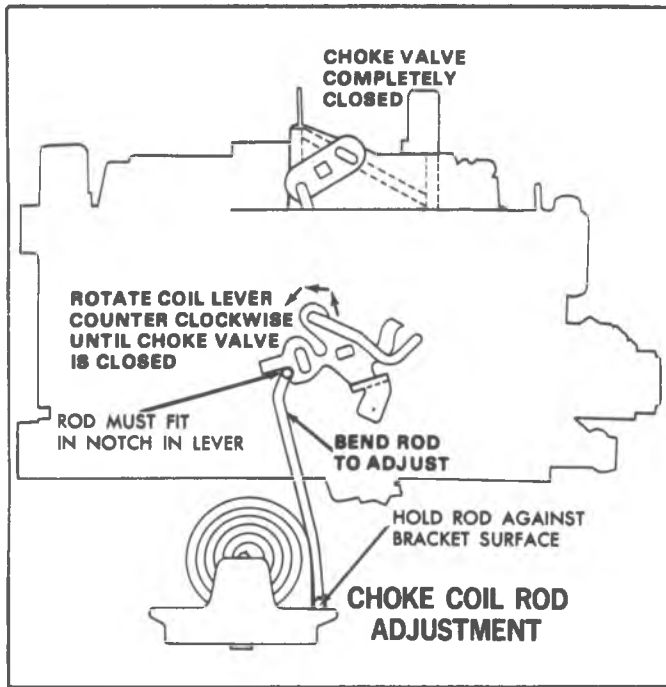

Fig. 14C-Choke Coil Rod Adjustment (4MV)

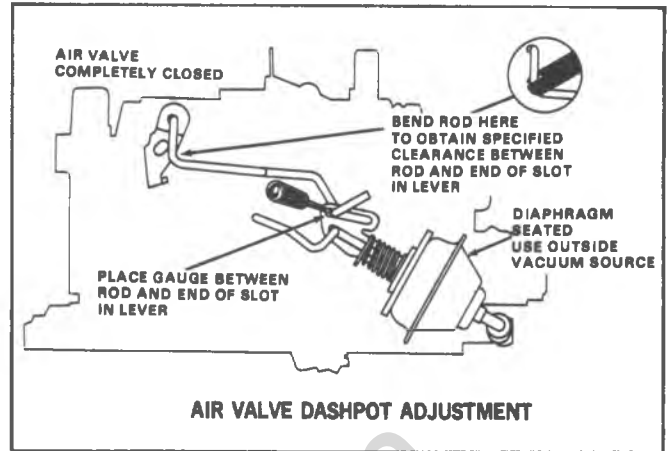

Fig. 15C-Air Valve Dashpot Adjustment (4MV)

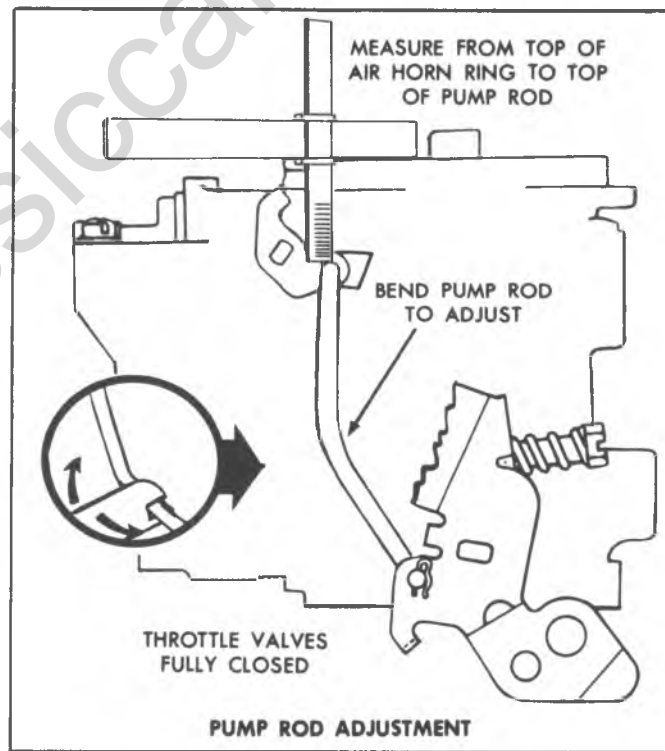

Fig. 16C-Accelerator Pump Rod Adjustment (2GV)

# SERVICE OPERATIONS

## (INCLUDING ADDITIONAL EXTERNAL SETTINGS AND ADJUSTMENTS)

### INDEX

Carburetor Removal..... 6M-24  
 Accelerators and Choke Controls ..... 6M-27  
 Air Cleaners ..... 6M-30

Fuel Pumps..... 6M-37  
 Special Tools ..... 6M-64

### ALL CARBURETORS

#### REMOVAL (Figs. K1, K2 and K3)

Flooding, stumble on acceleration and other performance complaints are, in many instances, caused by the presence of dirt, water, gum and varnish caused by stale fuel from prolonged vehicle storage, or other foreign matter in the carburetor. To aid in diagnosing the cause of the complaint, the carburetor should be carefully removed from the engine without draining the fuel from the bowl. The contents of the fuel bowl may then be examined for contamination as the carburetor is disassembled. Check filter.

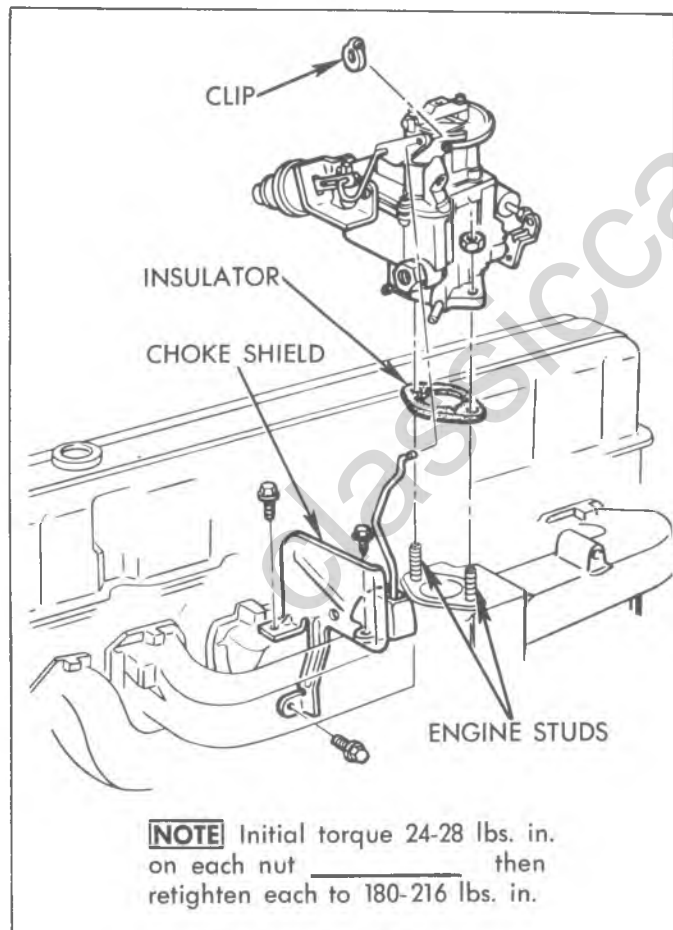

Fig. K1--Choke Coil Rod, L-6

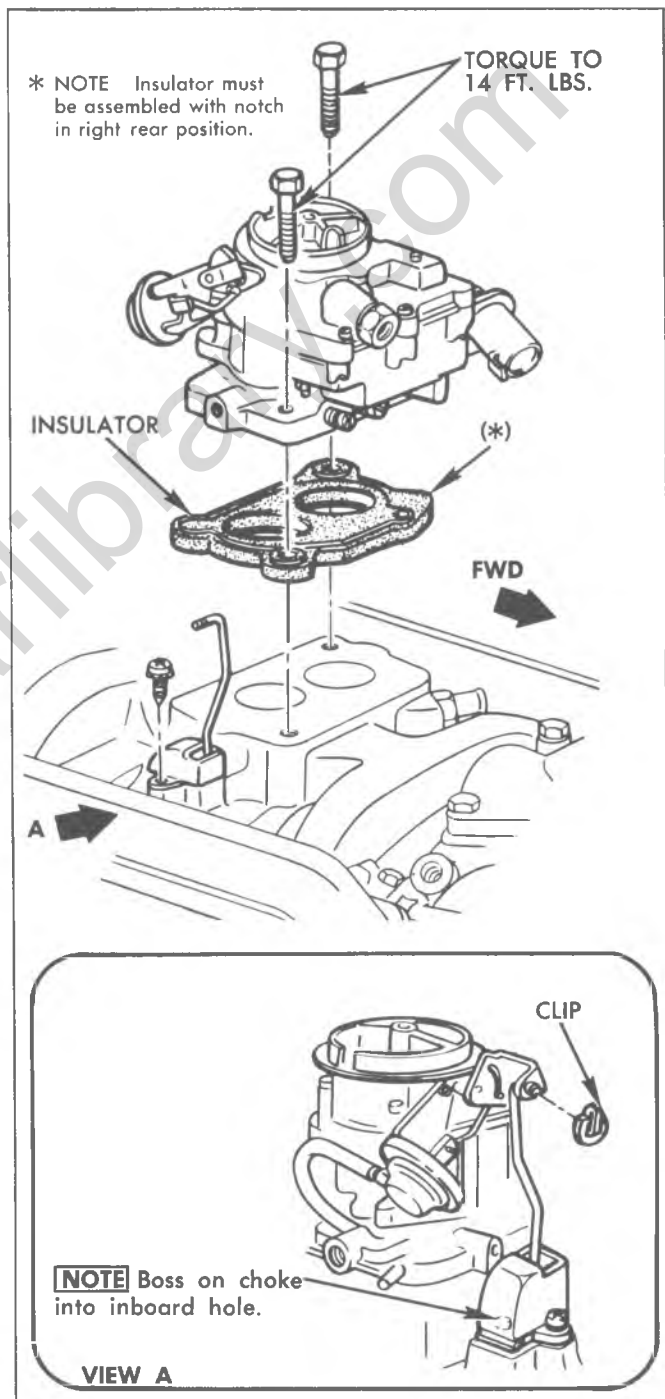

Fig. K2--Choke Coil Rod, 2Bbl. Carb. V-8

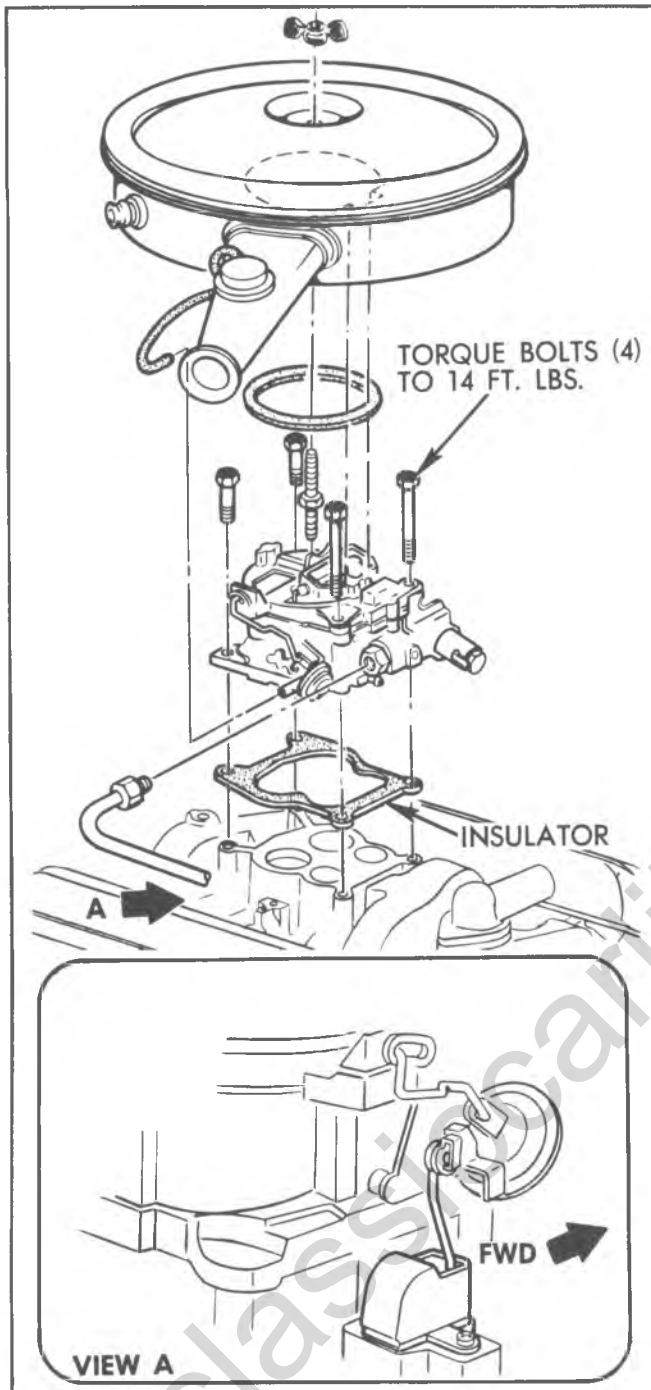

Fig. K3-Choke Coil Rod, 4MV Rochester

1. Remove air cleaner and gasket.
2. Disconnect fuel and vacuum lines from carburetor.
3. Disconnect choke coil rod.
4. Disconnect accelerator linkage.
5. If equipped with automatic transmission, disconnect TV linkage.
6. Remove vacuum hoses.
7. Remove idle stop electrical wiring from solenoid (if so equipped).

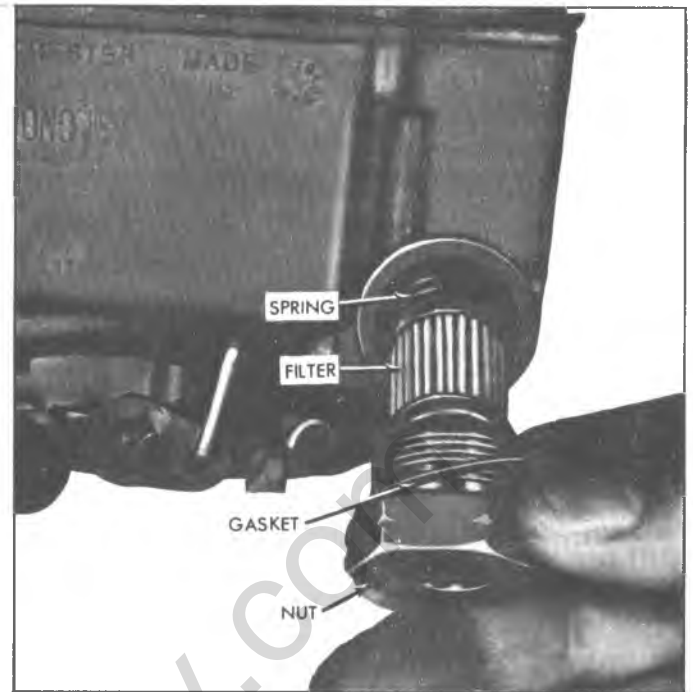

Fig. K4-Fuel Filter (Paper-Type) (Typical)

8. Remove carburetor attaching nut and/or bolts, gasket or insulator and remove carburetor.

### TEST BEFORE INSTALLATION

It is good shop practice to fill the carburetor bowl before installing the carburetor. This reduces the strain on the starting motor and battery and reduces the possibility of backfiring while attempting to start the engine. A fuel pump clamped to the bench, a small supply of fuel and the necessary fittings enable the carburetor to be filled and the operation of the float and intake needle and seat to be checked. Operate the throttle lever several times and check the discharge from the pump jets before installing the carburetor.

### INSTALLATION

1. Be certain throttle body and intake manifold sealing surfaces are clean.
2. Install new carburetor to manifold flange gasket or insulator (as required).
3. Install carburetor over manifold studs or holes.
4. Start vacuum and fuel lines at carburetor.
5. Install attaching nuts and/or bolts and tighten to specified torque shown.
6. Tighten fuel lines and install vacuum lines securely.
7. Connect and adjust accelerator and TV linkage.
8. Connect idle stop wiring connector to solenoid.
9. Connect choke coil rod.
10. Install air cleaner, adjust curb idle and low idle speeds per decal. (See specifications for idle stop

## 6M-26 ENGINE FUEL

solenoid adjustment and idle mixture adjustment; also, "Additional external settings and adjustments".)

### FUEL FILTER MAINTENANCE

1. Disconnect fuel line connection at inlet fuel filter nut.
2. Remove inlet fuel filter nut from carburetor with a box wrench or socket.
3. Remove filter element and spring (fig. K4).
4. Check paper element by blowing on fuel inlet end.

If filter does not allow air to pass freely, replace element. No attempt should be made to clean filters.

**NOTE:** Element should be replaced if plugged or if flooding occurs. A plugged filter will result in a loss of engine power or rough (pulsating) engine feel, especially at high engine speeds.

5. Install element spring, and install element in carburetor. Bronze filters must have small section of cone facing out.
6. Install new gasket on inlet fitting nut and install nut in carburetor and tighten securely.
7. Install fuel line and tighten connector.

### AUTOMATIC CHOKE COIL ASSEMBLIES

Refer to "External Adjustments" for choke coil adjustment procedures and typical installed views.

#### Choke Coil Replacement

##### In-Line Engines (Fig. K1)

**NOTE:** The following procedures refer to all IN-LINE engines.

1. Remove air cleaner and disconnect choke rod upper clip.
2. Remove bolt attaching choke coil to manifold, and remove choke coil and choke rod as an assembly.
3. Disconnect choke rod from choke coil.
4. Connect choke rod to new choke coil and install assembly on manifold.
5. Install bolt and tighten securely.
6. Adjust and connect choke rod as outlined.
7. Start and warm-up the engine then check operation of choke and install air cleaner.

##### V8 Engines (Figs. K2-K3)

1. Remove air cleaner and disconnect choke rod upper clip.
2. Remove choke coil as follows:

#### WITH ROCHESTER 4MV AND 2GV CARBURETORS

Remove the choke coil shield by prying with a screw driver on the small tangs at base of shield, then lift shield carefully over rod.

Remove choke rod, bracket screw and choke coil assembly.

3. Install a new choke coil assembly being sure the locator is in the hole of the intake manifold and install mounting screw.

4. Complete installation as follows:

#### WITH ROCHESTER 4MV AND 2GV CARBURETORS

Install the choke rod and adjust as necessary (without choke coil shield installed).

Disconnect choke rod upper end and lower choke coil shield over choke rod and install over choke coil.

5. Be sure choke valve moves freely from full open to full closed position.
6. Start and warm up the engine and check operation of the choke.
7. Install the air cleaner.

### ON-THE-VEHICLE ADJUSTMENTS

Final curb idle and fast idle settings should be made on the vehicle using a tachometer. All idle speeds in 1974 are to be set with the air conditioning in the OFF position unless otherwise indicated. Idle speed and mixture settings must be made with the air cleaner installed. Warm engine to normal operating temperature, choke valve and thermostatic air cleaner valve must be in full open positions. Idle settings must follow procedure shown on the, "Vehicle Emission Control Information" sticker, sometimes referred to as tuneup sticker.

#### IDLE STOP SOLENOID (CURB IDLE-LOW IDLE) ADJUSTMENT

With engine at normal operating temperature, air cleaner installed, choke open, and air conditioning off, if so equipped.

**CAUTION:** Set parking brakes and block the drive wheels.

1. Disconnect fuel tank hose vapor canister.
2. Disconnect distributor vacuum hose at the distributor. Plug hose lead-to carburetor.
3. With engine running;

#### ONE BARREL CARBURETORS

**CAUTION:** During adjustment, do not turn the solenoid more than one complete turn without first disconnecting the electrical wiring.

- Turn the solenoid clockwise to increase RPM, counterclockwise to decrease RPM. Refer to Specifications, Section 6M, under "Other Adjustments", column No. 2, for curb idle speed (Idle Stop Solenoid-Energized).
- Set low idle speed (with solenoid de-energized) to 450 RPM by using an allen head wrench (located at the end of this solenoid). Turn to adjust.

## TWO BARREL AND FOUR BARREL CARBURETORS

- Disconnect electrical connection at the end of the idle stop solenoid.
- Adjust carburetors low idle (Adjustment screw on low step of cam) to Specifications in Column No. 2, Note (3).
- Set dwell and timing and recheck low idle speed.
- Reconnect electrical connector to the solenoid. Open the throttle momentarily and adjust the solenoid plunger screw to the specified curb idle speed (RPM). See Specifications, Section 6M, under "Other Adjustments".

## ACCELERATOR AND CHOKE CONTROLS

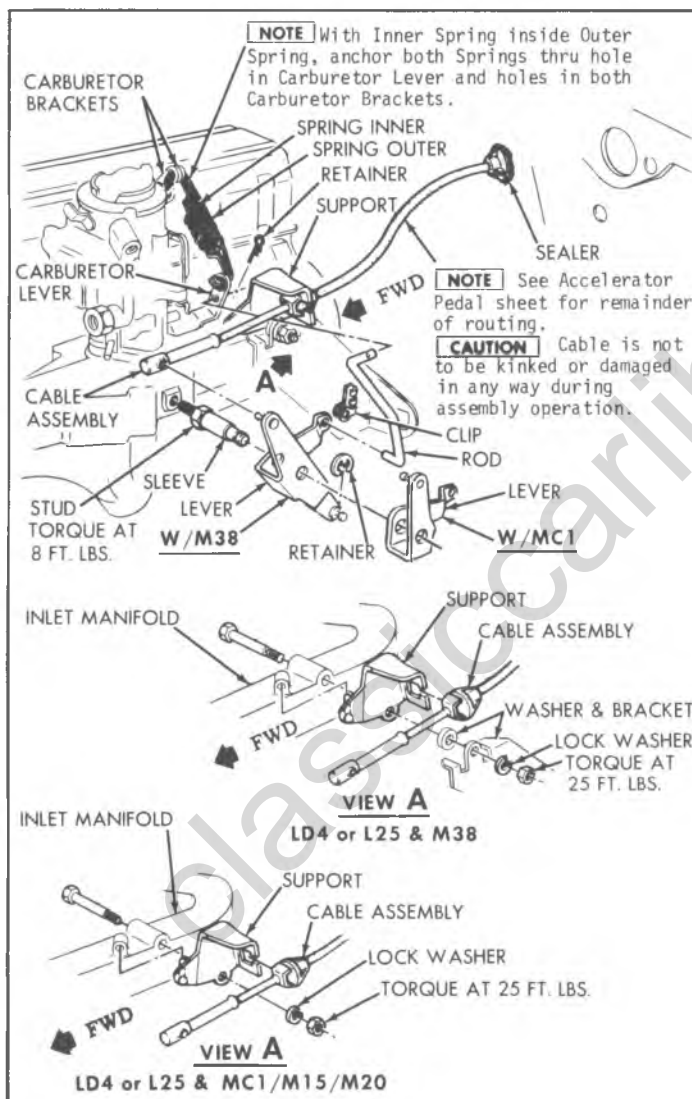

Fig. K5--Accelerator Controls, CS and KS 10 thru 30 Series

### THROTTLE LINKAGE (Fig. K5 thru K18)

The throttle control system is of the cable type. There are no throttle linkage adjustments, a reference between the bottom of the accelerator pedal roller and floor pan should be used only as a check for bent bracket assemblies. Check torque references in Figures K5 thru K18. Check for correct opening and closing positions by operating accelerator pedal in car. Cable routing attachment, carburetor positioning for proper assembly should be noted by some of the following illustrations.

**NOTE:** If any binding is present, check for correct routing of cable or pedal interference with carpets.

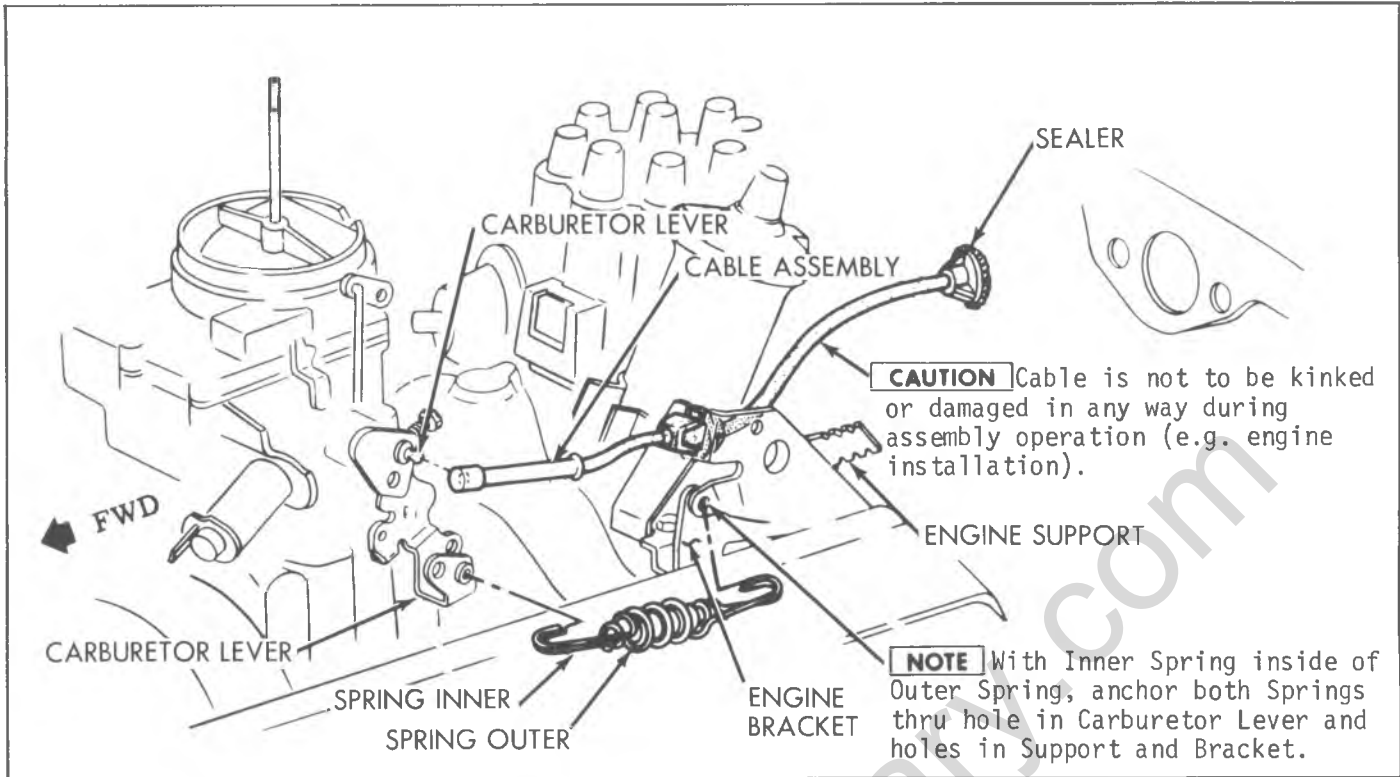

Fig. K6--Accelerator Controls and Cable, CS and KS

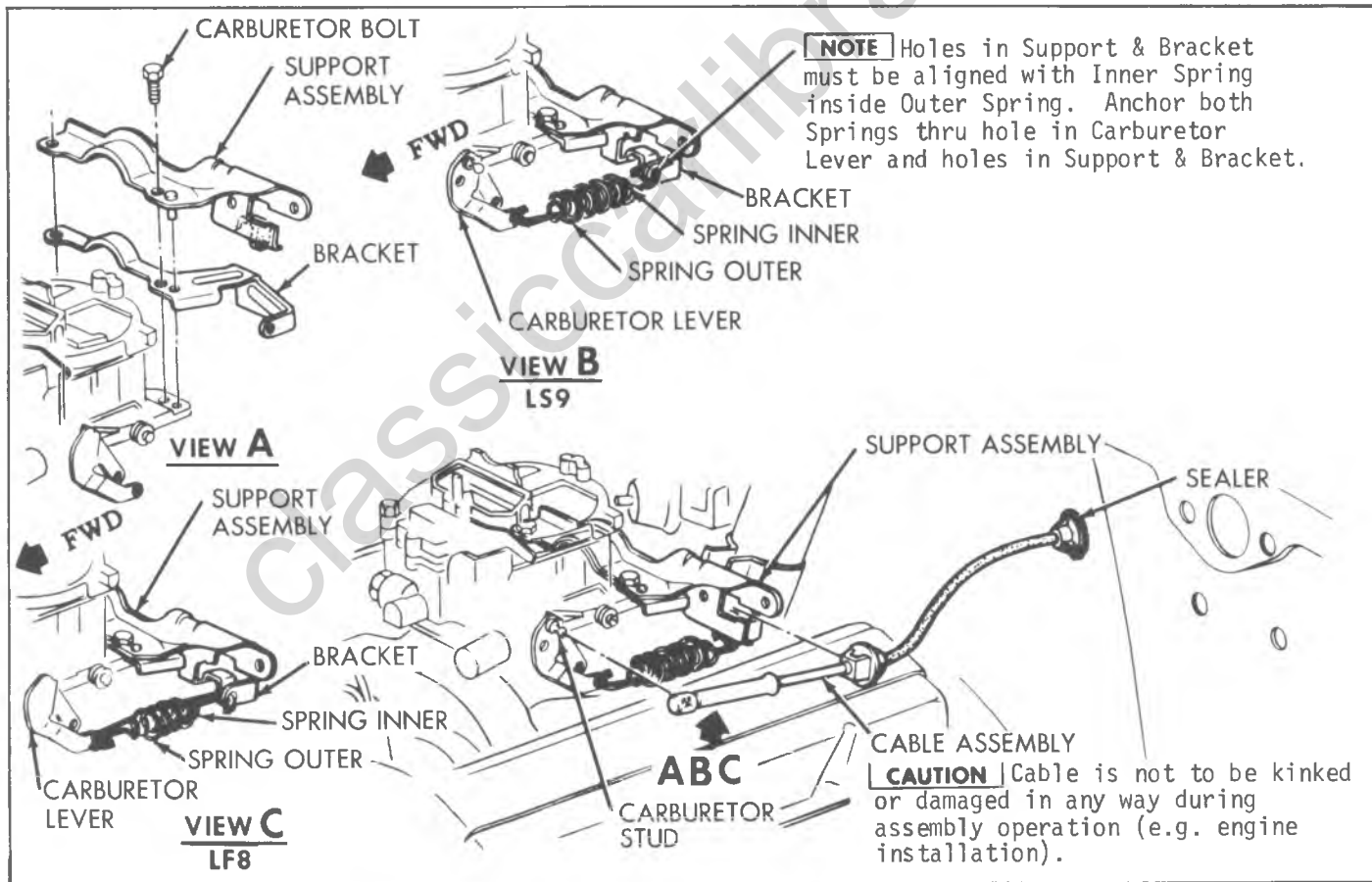

Fig. K7--Accelerator Controls CE-KE 10 and 20 and CE-30 Series w/307 Engine

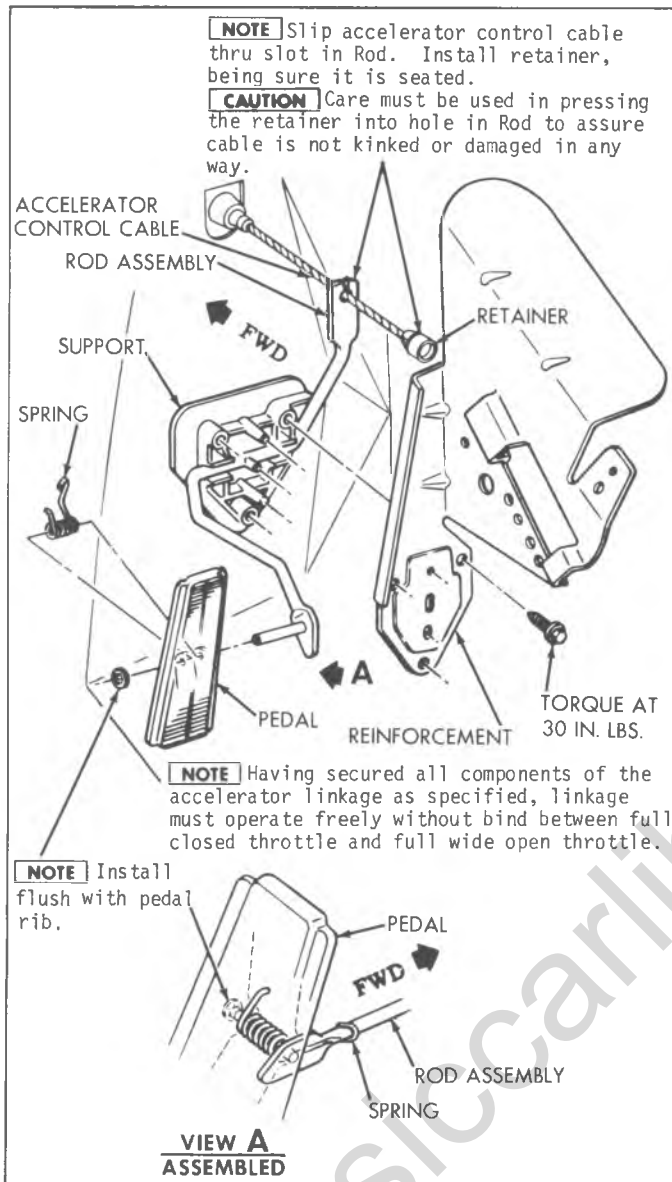

Fig. K8—Accelerator Pedal and Controls, C, K P10 thru 30 Series

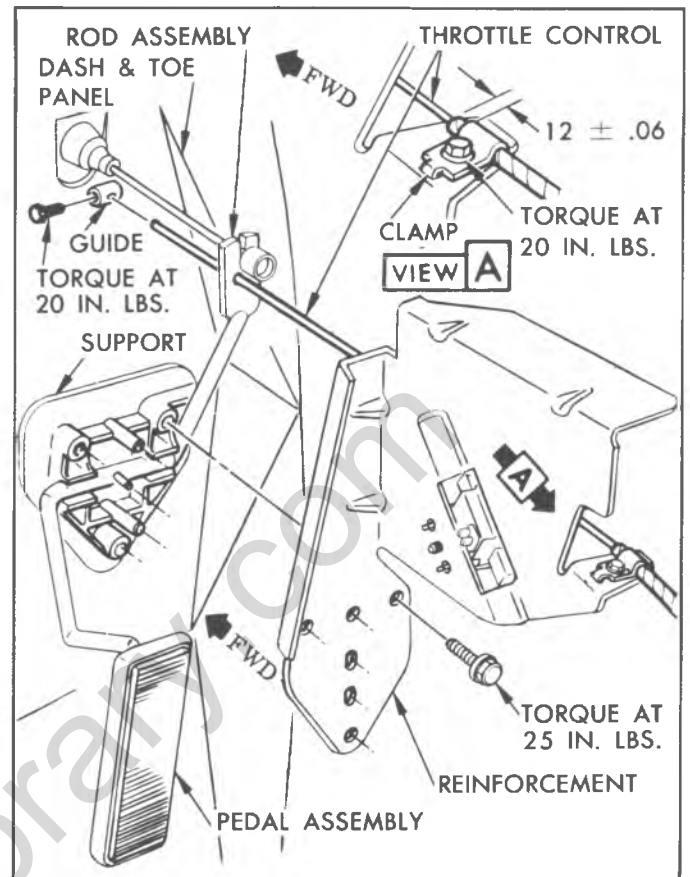

Fig. K9—Accelerator Controls (Manual Throttle) C-K

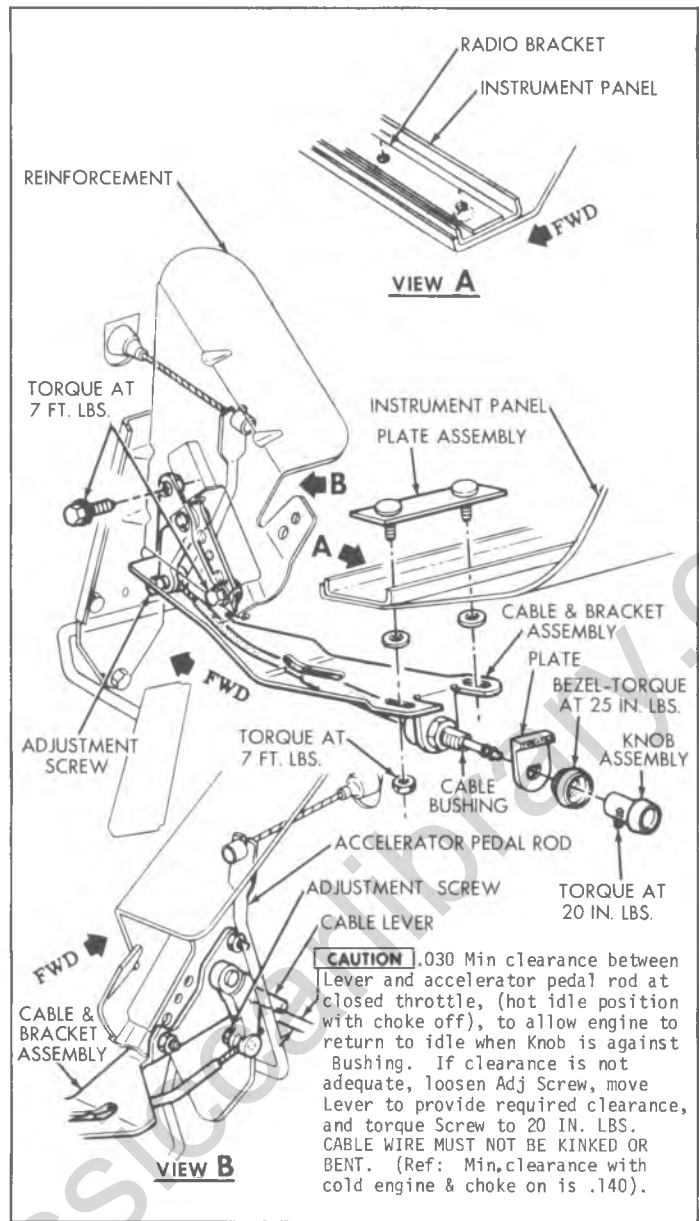

Fig. K10—Hand Throttle Controls, C-K

## AIR CLEANERS

### INDEX

General Description.....	6M-30	Element Replacement.....	6M-31
Maintenance and Service Procedures .....	6M-31	Part Replacement.....	6M-32

## GENERAL DESCRIPTION

Air cleaners on all models operate primarily to remove dust and dirt from air before it is drawn into the carburetor and engine. The air cleaner also helps to

reduce engine noise and quenches any flame that may be caused by engine backfiring through the carburetors.

Two types of air cleaners are used on trucks. They are



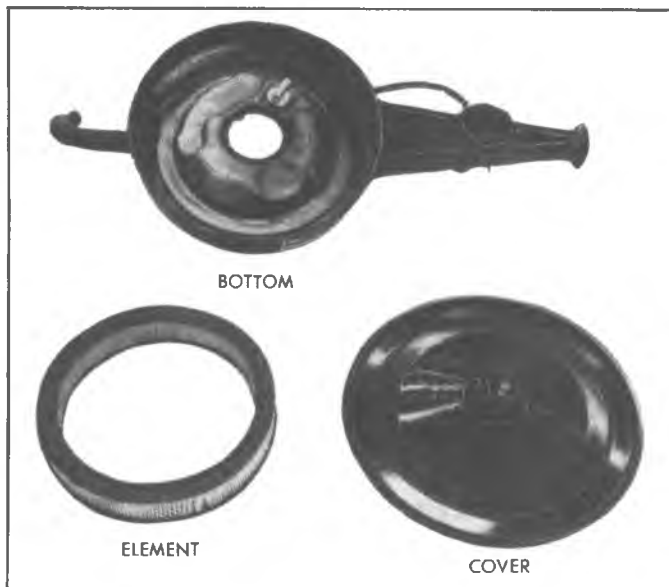

Fig. 1A--Paper Element Air Cleaner

the oil wetted paper element air cleaner, and the polywrap element air cleaner.

The oil wetted paper element air cleaner (fig. 1A) consists of an accordion pleated oiled paper filter supported by wire mesh with a plastisol seal on both top and bottom

## MAINTENANCE AND SERVICE

**CARBURETOR AIR CLEANER ELEMENT**-Under normal operating conditions, the carburetor air cleaner should be replaced every 24,000 miles on V-8 engines and 12,000 miles on L-6 engines. Operation of vehicle in dusty areas will cause rapid clogging or element and enrichment of carburetor mixture. Under these conditions, the element must be replaced more frequently.

**THERMOSTATICALLY CONTROLLED AIR CLEANER**-The air cleaner should be inspected to make certain that all hoses and ducts are intact and correctly installed. Operational function should be checked by inspecting position of valve in air intake. With engine stopped, valve should be open. At underhood temperature below 100 degrees F, with engine running, valve should be partially or fully closed. As engine underhood temperature rises, the valve should open.

### PAPER ELEMENT REPLACEMENT (PAPER FILTER ONLY)

NOTE: See below part replacement.

1. Remove air cleaner cover.
2. Remove element.
3. Disconnect vacuum signal hose and CCV hose. Discard air cleaner element and gasket.

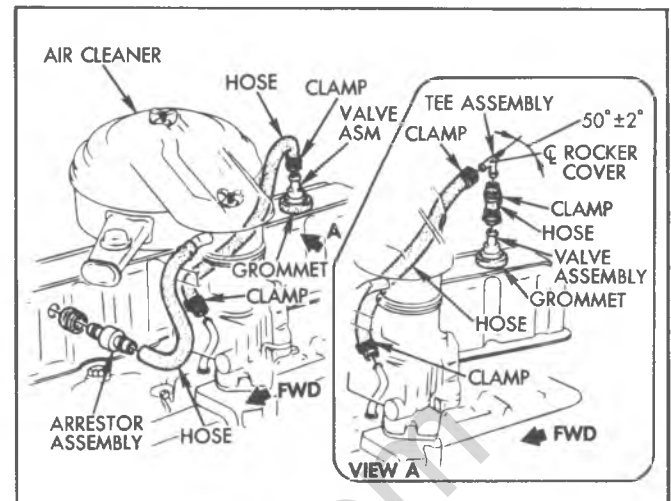

Fig. 2A--Engine Ventilation, (L-6)

The polywrap element air cleaner consists of a paper element in addition to a polyurethane band.

Air temperature is automatically controlled by a thermostatic valve which selects warmed air from the heat stove and/or cooler air from the engine compartment.

4. Clean bottom section of air cleaner, gasket surfaces and air cleaner cover thoroughly.

NOTE: Check air cleaner cover seal for tears or cracks.

5. Install bottom section of air cleaner with a new air cleaner gasket. Align heat stove tube.
6. Install new paper element in bottom section of air cleaner with either end up.
7. Install air cleaner cover. (Do not over-torque wing nut).

### POLYWRAP ELEMENT REPLACEMENT (PAPER FILTER WITH POLYURETHANE BAND)

NOTE: See below part replacement.

The replacement period for the polywrap paper element is the same as for the above "paper element only". However, each time the polywrap paper element is replaced, also, the polyurethane band should be cleaned, as outlined below, inspect and reoil or replace.

#### Cleaning the Polyurethane Band

1. Remove the polyurethane band from the paper filter.

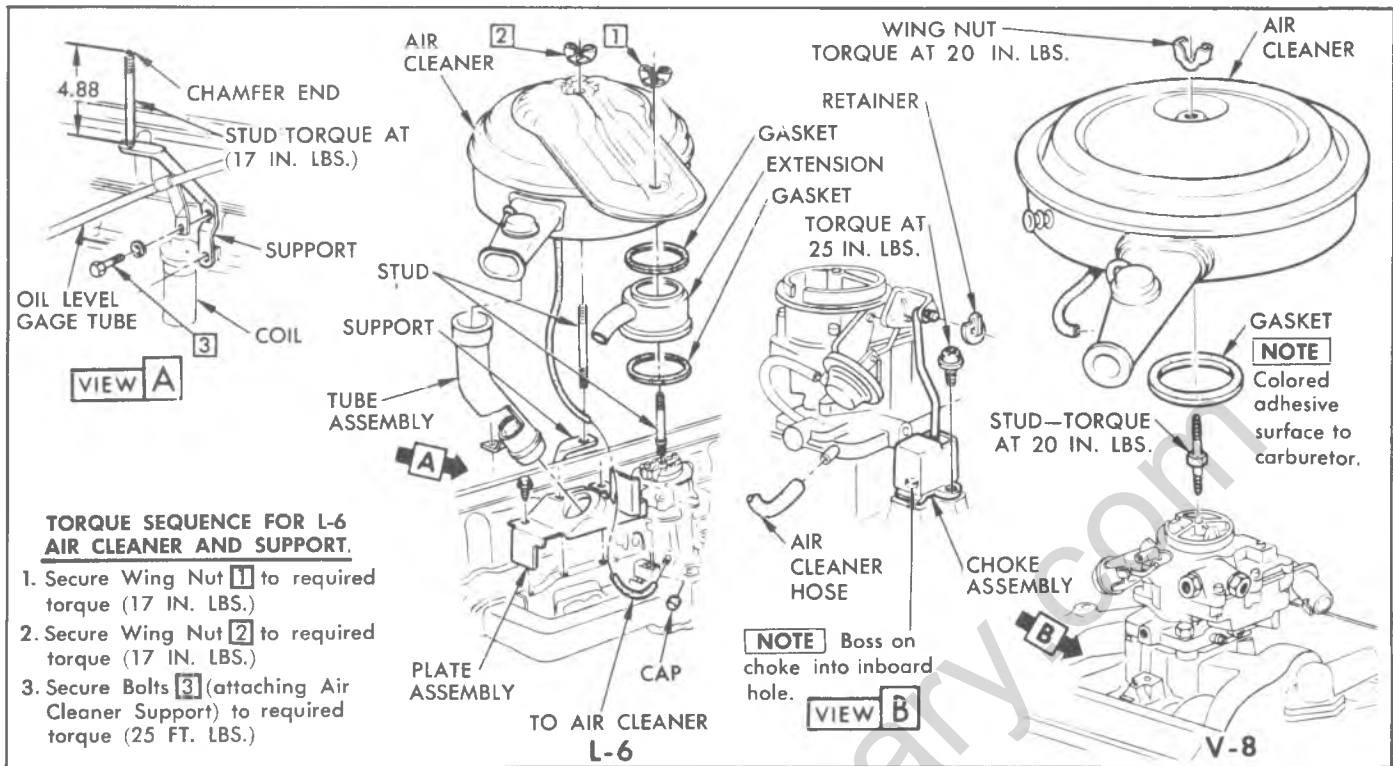

Fig. 3A--Air Cleaner and Heat Stove, Truck (Base L6 and V8) except P and G Series

2. If not torn, wash the polyurethane band in kerosene or mineral spirits then squeeze out excess solvent (as dry as possible) (Fig. 8A).

**NOTE:** Never use a hot degreaser or any solvent containing acetone or similar solvent; also, never shake, swing or wring the element to remove excess solvent as this may tear the polyurethane material. Instead, "squeeze" the excess solvent from the element.

3. Inspect the polywrap band for tears and replace if necessary.
4. Dip the band into light engine oil and squeeze out excess oil.
5. Install the polyurethane band around the outer surface of the paper filter (Fig. 9A).

## PART REPLACEMENT

It should be noted that different type paper elements are used; one with the polyurethane band and another type used for paper element replacement without a polyurethane band.

## THERMOSTATICALLY CONTROLLED AIR CLEANER

This system (fig. 10A and 11A) is designed to improve carburetor operation and engine warm-up characteristics. It achieves this by keeping the air entering the carburetor at a temperature of at least 100 degrees F or more.

The thermostatic air cleaner system includes a temperature sensor, a vacuum motor, and control damper assembly mounted in the air cleaner, vacuum control hoses, manifold heat stove and connecting pipes. The vacuum motor is controlled by the temperature sensor. The vacuum motor operated the air control damper assembly to regulate the flow of hot air and underhood air to carburetor. The hot air is obtained from the heat stove on the exhaust manifold.

## Inspection Visual

1. Check for proper and secure connections of heat pipe and hoses.
2. Check for kinked or deteriorated hoses. Repair or replace as required.

## Operational

1. Remove air cleaner cover and install temperature gauge (Tool J-22973) as close as possible to sensor (fig. 12A).

Reinstall cover without wing nut. (Temperature must be below 85 degrees F before proceeding).

2. With the engine "OFF", observe damper door position through snorkel opening. Snorkel passage should be open. Fig. 11A, View A. If not, check for binds in linkage.
3. Start and idle engine. With air temperature below 85 degrees F, snorkel passage should be closed. Fig. 11A, View B. When damper door begins to open

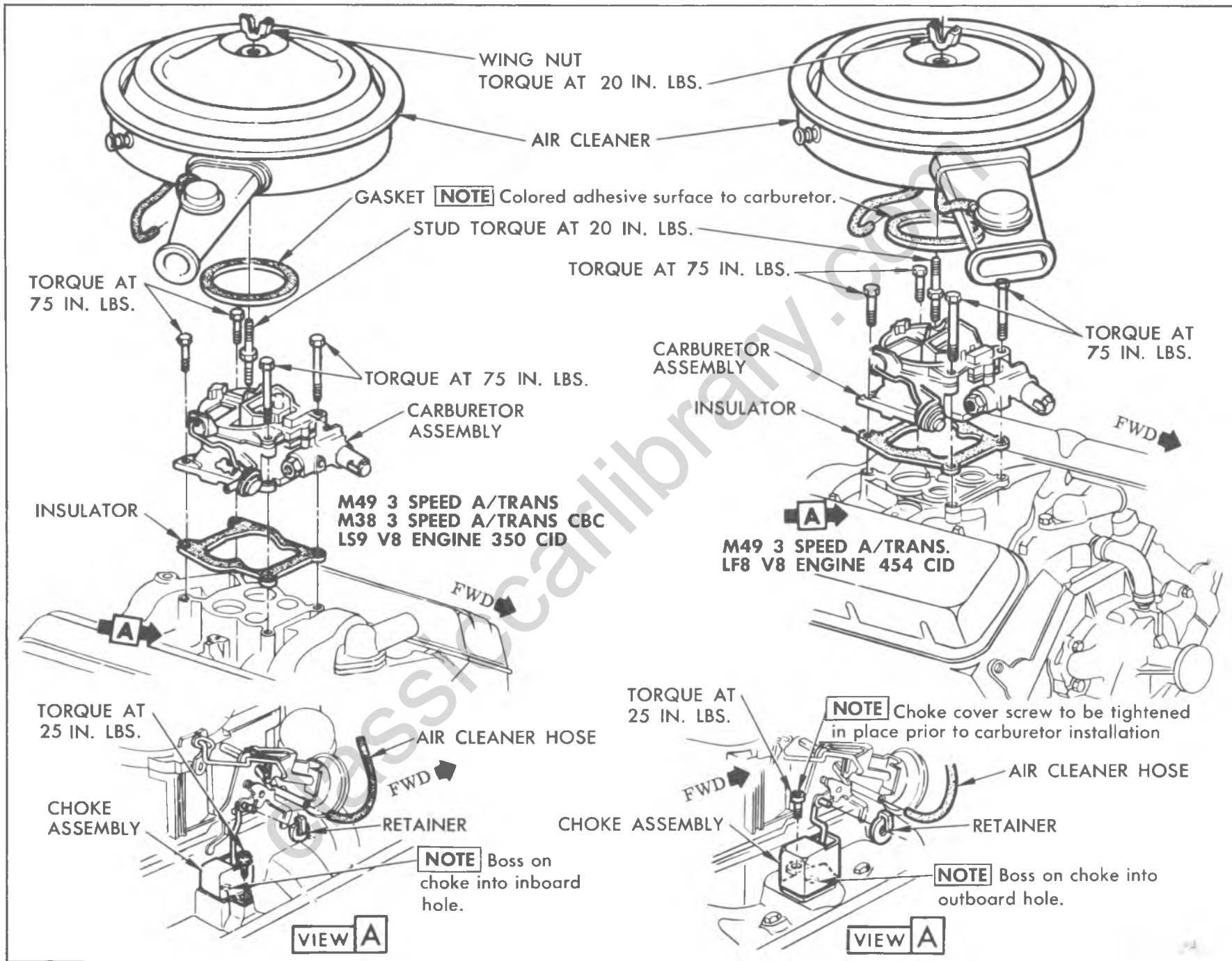

Fig. 4A--Carburetor, Air Cleaner and Choke, C-K Series

## 6M-34 ENGINE FUEL

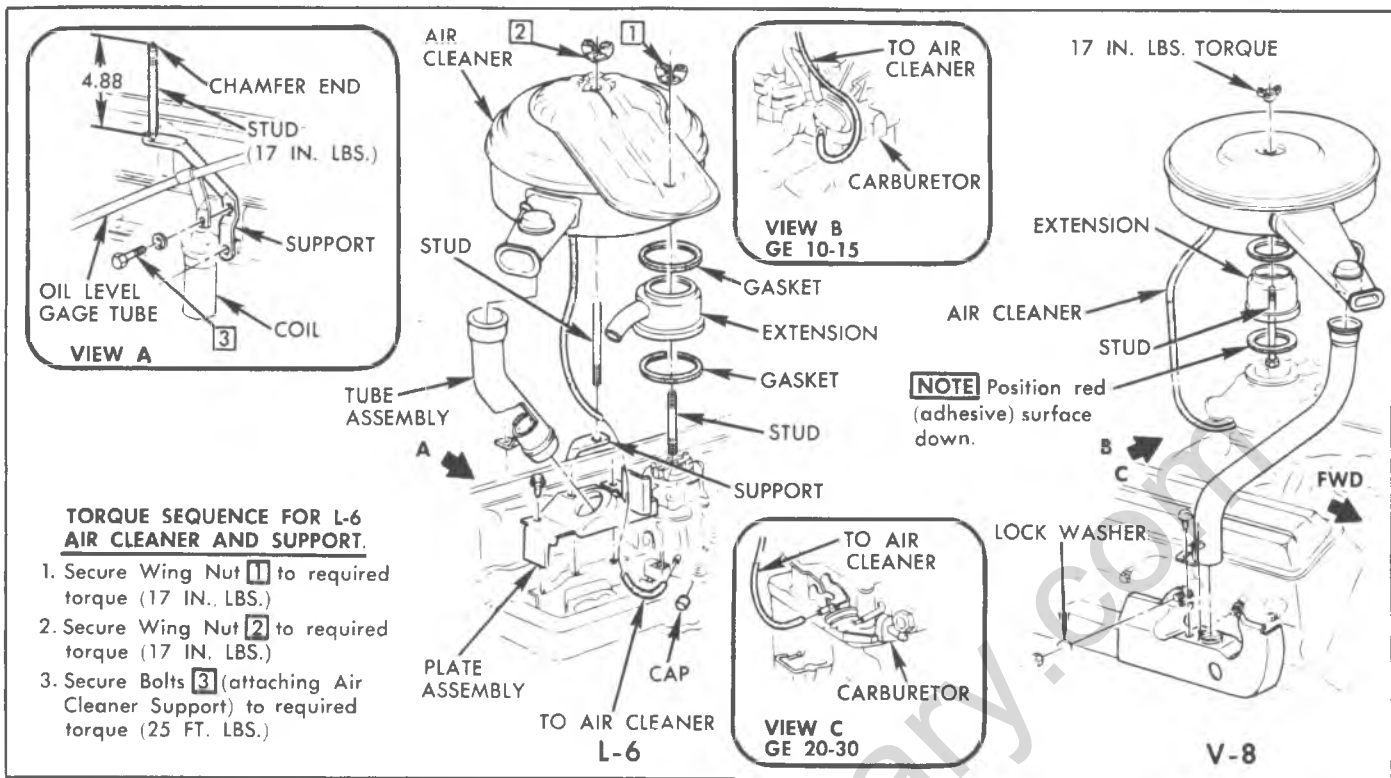

Fig. 5A--Air Cleaner and Heat Stove G-Van L-6 and V-8

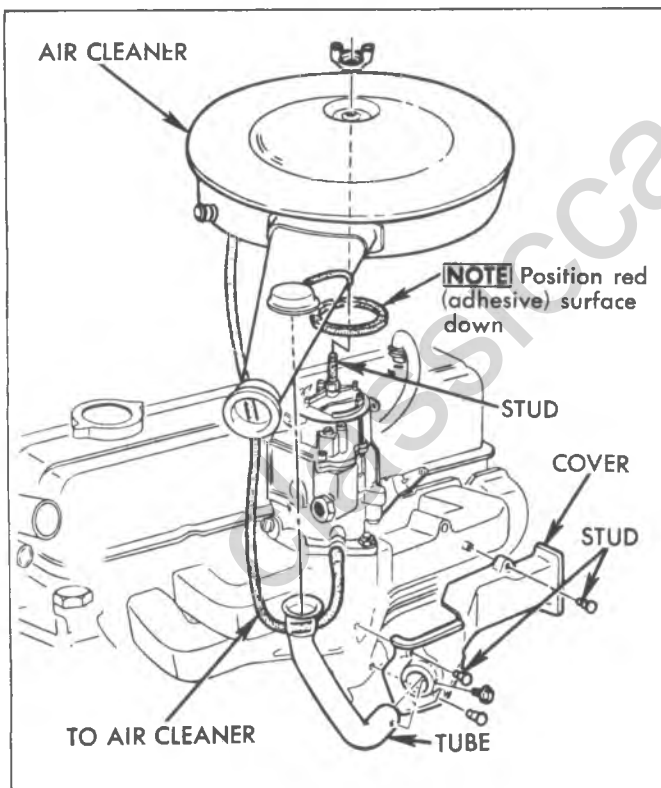

Fig. 6A--Air Cleaner, Heat Stove and Tube-CS 10 (03)

snorkel passage, remove air cleaner cover and observe thermometer reading. It should be between 85 degrees F and 115 degrees F.

4. If damper door does not close completely or does not open at correct temperature, continue with the following vacuum motor check:
  - a. Turn off engine. Disconnect diaphragm assembly vacuum hose at sensor unit.
  - b. Apply at least 9 in. Hg. of vacuum to diaphragm assembly through the hose. This can be done by mouth. Damper door should completely close snorkel passage when vacuum is applied. If not check to see if linkage is hooked up correctly and for a vacuum lean.
  - c. With vacuum applied, bend or clamp hose to trap vacuum in diaphragm assembly (fig. 13a).

Damper door should remain in position (closed snorkel passage). If it does not, there is a vacuum leak in diaphragm assembly. Replace diaphragm assembly.
5. If vacuum motor check is found satisfactory, replace sensor unit.

## VACUUM MOTOR REPLACEMENT

### Removal

1. Remove air cleaner from engine.

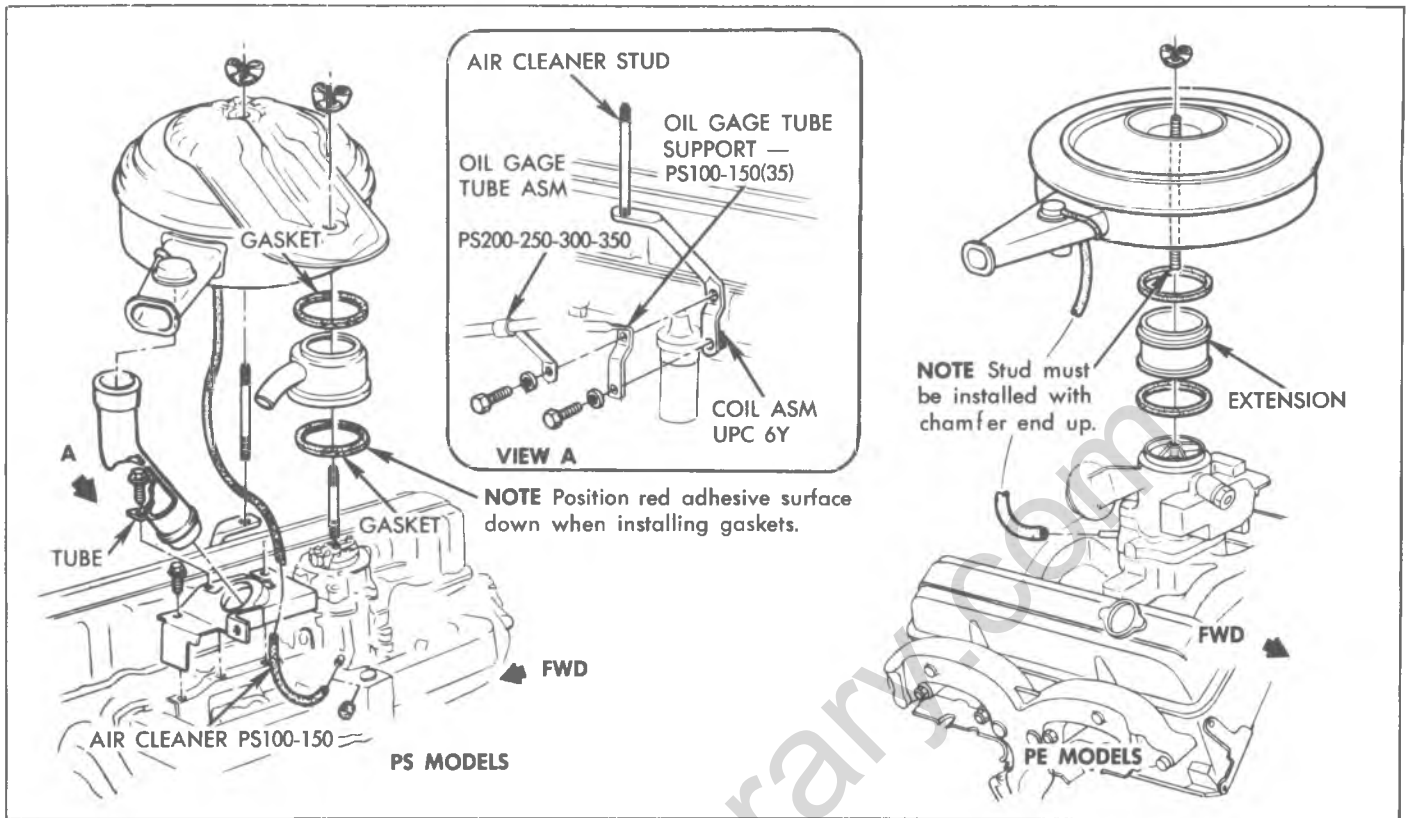

Fig. 7A--Air Cleaner and Heat Stove, P Series



Fig. 8A—Cleaning the Polyurethane Band

2. Drill out spot welds fastening vacuum motor retaining strap to snorkel tube.
3. Remove vacuum motor by lifting and unhooking linkage rod from damper door.

**Replacement**

1. Drill 7/64" hole in snorkel tube at center of vacuum motor retaining strap (fig. 14a).

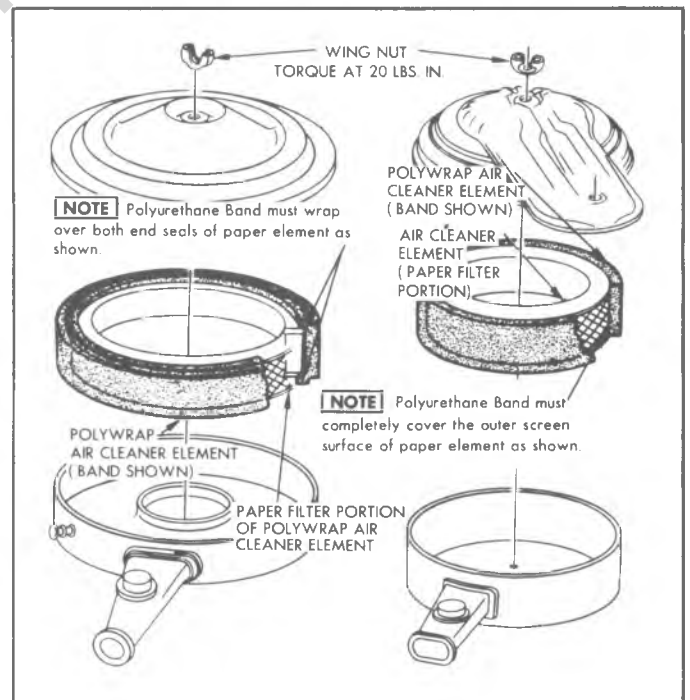

Fig. 9A—Installing the Polyurethane Band

2. Connect vacuum motor linkage to damper door. Fasten retaining strap to air cleaner with sheet metal screw.

## 6M-36 ENGINE FUEL

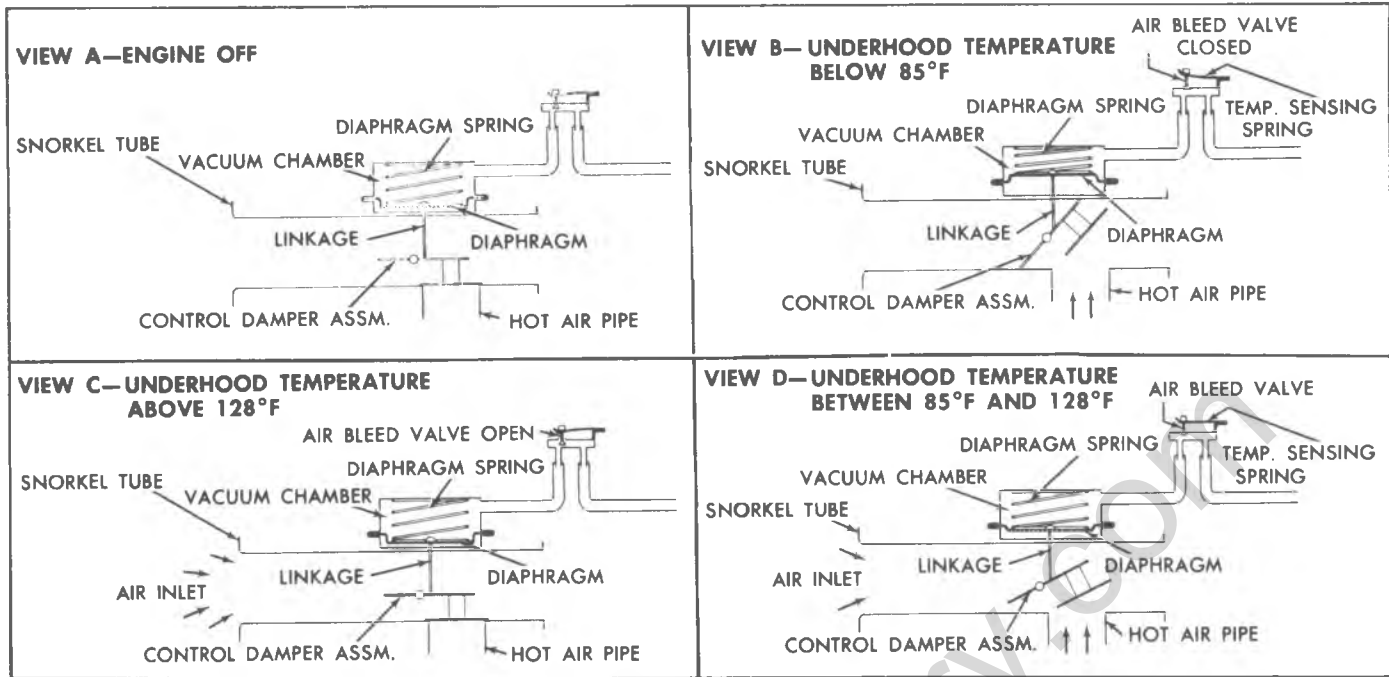

Fig. 11A--Air Cleaner Operation

3. Replace air cleaner on engine and check operation of vacuum motor and control damper assembly.

## TEMPERATURE SENSOR REPLACEMENT

### Removal

1. Remove engine air cleaner and disconnect vacuum hose at sensor.
2. Pry up tabs of sensor retaining clip (fig. 15a).

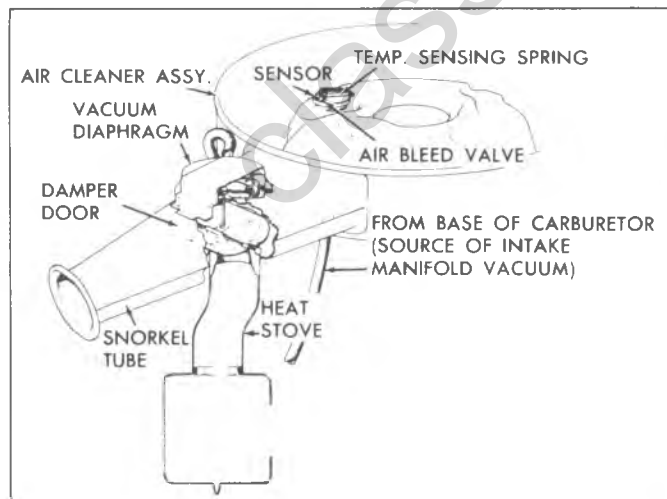

Fig. 10A--Thermostatically Controlled Air Cleaner

NOTE: Observe position of sensor, new sensor must be installed in this same position.

3. Remove clip and sensor from air cleaner.

### Replacement

1. Install sensor and gasket assembly in air cleaner in position as noted above.
2. Press retaining clip on sensor. Support the sensor on its side to prevent damage to the control mechanism in the center.
3. Install air cleaner on engine and connect vacuum hoses.



Fig. 12A--Temperature Gauge Installation



Fig. 13A-Checking Vacuum Diaphragm

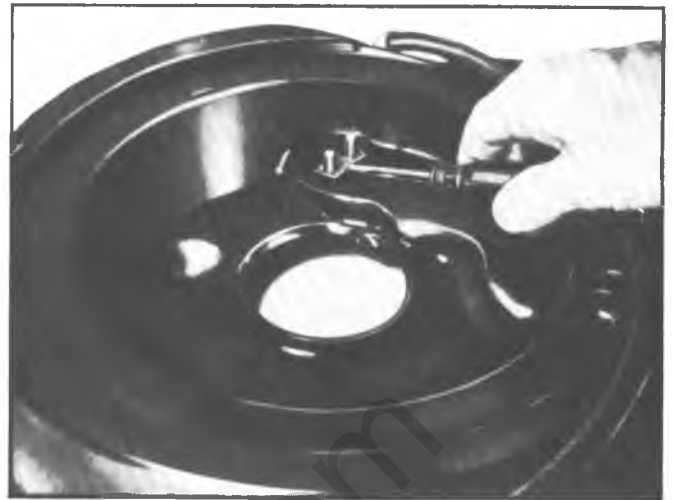

Fig. 15A-Removing Sensor Unit

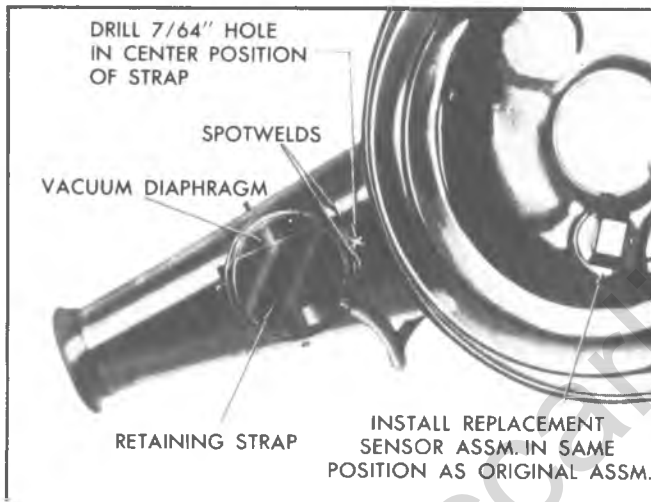

Fig. 14A-Vacuum Diaphragm Replacement

## FUEL PUMP

### INDEX

General Description.....	6M-37	Test .....	6M-38
Service Procedures.....	6M-37	Removal.....	6M-39
Inspection .....	6M-37	Installation.....	6M-39

## GENERAL DESCRIPTION

The fuel pump (fig. 1P and 2P) used on all vehicles covered in this manual is the diaphragm type. The pump is actuated by an eccentric located on the engine camshaft. On in-line engine, the eccentric actuates the rocker arm. On V-8 engines, a push rod (located between the camshaft eccentric and fuel pump) actuates the pump

rocker arm. Because of design, this pump is serviced as an assembly only.

### INSPECTION

The fuel pump (fig. 3P) should be checked to make sure

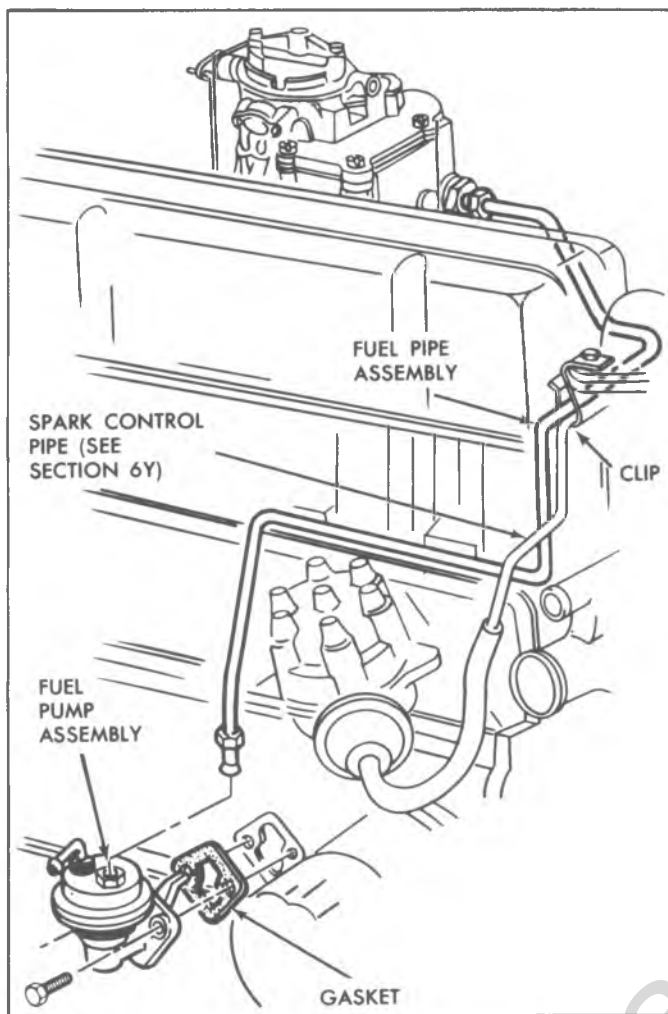

Fig. 1P--Fuel Pump and Pipe, L-6

the mounting bolts and inlet and outlet connections are tight.

### TEST

Always test pump while it is mounted on the engine and be sure there is gasoline in the tank.

The larger line from the tank to the pump is the suction side of the system and the line from the pump to the carburetor is the pressure side of the system. A leak on the pressure side, therefore, would be made apparent by dripping fuel, but a leak on the suction would not be apparent except for its effect of reducing volume of fuel on the pressure side.

1. Tighten any loose line connections and look for bends or kinks in lines.
2. Disconnect fuel pipe at carburetor. Disconnect distributor to coil primary wire so that engine can be cranked without firing. Place suitable container at end of pipe and crank engine a few revolutions. If little or no gasoline flows from open end of pipe then fuel pipe is clogged or pump is inoperative.

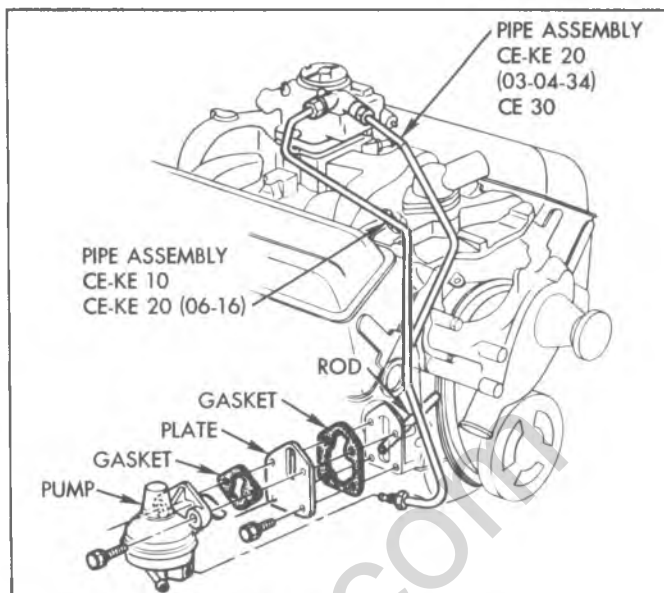

Fig. 2P--Fuel Pump and Pipe, V-8

Before removing pump disconnect fuel pipe at gas tank and outlet pipe and blow through them with an air hose to make sure they are clear. Reconnect pipes and retest while cranking engine.

**CAUTION:** Whenever the engine is cranked remotely at the starter, with a special jumper cable or other means the distributor primary lead must be disconnected from the negative post on the coil and the ignition switch must be in the "ON" position. Failure to do this will result in a damaged grounding circuit in the ignition switch.

3. If fuel flows from pump in good volume from pipe at carburetor, check fuel delivery pressure to be

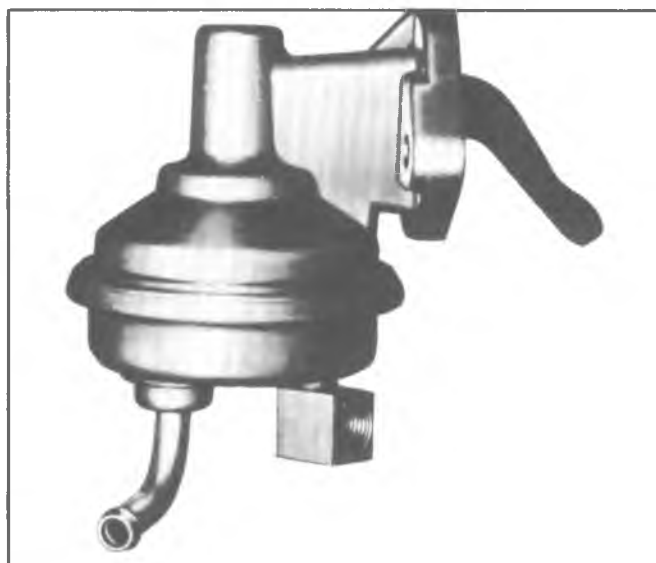

Fig. 3P--Fuel Pump (Non-Serviceable)



certain that pump is operating within specified limits as follows:

- a. Attach a fuel pump pressure test gauge to disconnect end of pipe.
- b. Run engine at approximately 450-1,000 rpm (on gasoline in carburetor bowl) and note reading on pressure gauge.
- c. If pump is operating properly the pressure will be within specifications and will remain constant at speeds between 450-1,000 rpm. If pressure is too low, too high, or varies significantly at different speeds, the pump should be replaced.

## REMOVAL

**NOTE:** When connecting fuel pump outlet pipe fitting always double wrench to avoid possible damage of pump.

1. Disconnect fuel inlet and outlet pipes at fuel pump.
2. Remove fuel pump mounting bolts and remove pump and gasket.
3. On V8 engines if push rod is to be removed, remove pipe plug and push rod (454 cu. in. engines), and fuel pump adapter and gasket and push rod 350 and 400 cu. in. engines).

## INSTALLATION

1. On V8 engines, if fuel pump push rod has been

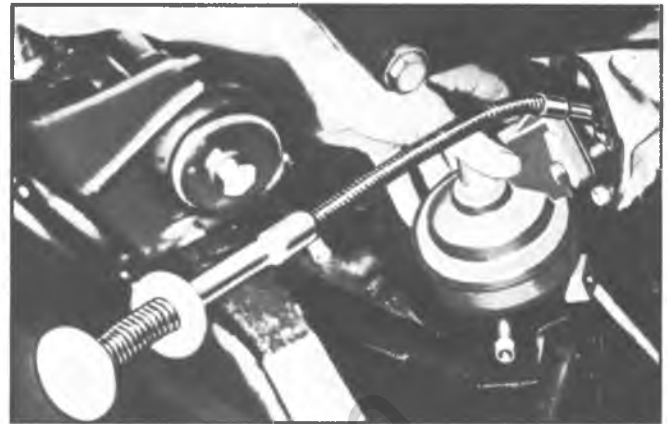

Fig. 4P--Installing V-8 Engine Fuel Pump

removed, install push rod and pipe fitting or fuel pump adapter using gasket sealer on gasket or pipe fitting.

2. Install fuel pump using a new gasket and tighten securely. Use sealer on fuel pump mounting bolt threads.

**NOTE:** On V8 engines, a pair of mechanical fingers or heavy grease may be used to hold fuel pump push rod while installing fuel pump (fig. 4P).

3. Connect fuel pipes to pump.
4. Start engine and check for leaks.

# CARBURETOR DIAGNOSIS

## MODELS M-MV, 2G-2GV, 4M-4MV

### INDEX

Rochester Monojet (1 bbl.) Carburetor ..... 6M-40  
 Rochester 2GV (2 bbl.) Carburetor ..... 6M-48

Rochester 4MV (4 bbl.) Carburetor..... 6M-55  
 Fuel Pump ..... 6M-63

### PROPER CARBURETOR OPERATION IS DEPENDENT UPON THE FOLLOWING

1. Fuel Supply
2. Linkage and emission control systems.
3. Engine compression.
4. Ignition system firing voltage
5. Ignition spark timing
6. Secure intake manifold
7. Engine temperature
8. Carburetor adjustments

### ANY PROBLEMS IN THE ABOVE AREAS CAN CAUSE THE FOLLOWING

1. No start or hard starting - (hot or cold)
2. Rough engine idle and stalling
3. Hesitation on acceleration
4. Loss of power on acceleration and top speed
5. Engine to run uneven or surge
6. Poor fuel economy
7. Excessive emissions

**BEFORE PROCEEDING WITH CARBURETOR DIAGNOSIS, CHECK THE PRECEDING ITEMS FIRST.**

## ROCHESTER CARBURETOR DIAGNOSIS MODELS M, MV-2G, 2 GV-4M, 4MV.

NOTE: These problems can be caused by many things other than carburetor. Check the following engine tune-up items before proceeding with carburetor items.

Engine compression, spark plugs, ignition point gap and condition, ignition timing, fuel pump pressure and volume, plugged fuel filters or fuel lines and intake manifold for vacuum leaks. Make sure all emission control parts are installed and operating properly. This includes all emission systems solenoids and hoses where used.

Problems of roughness slight hesitation, surge or poor fuel economy should not be diagnosed before an allowable engine break in period.

### ALL MODELS M, MV — SINGLE BARREL

#### Problem:

ENGINE CRANKS (TURNS OVER) WILL NOT START OR STARTS HARD WHEN COLD.

POSSIBLE CAUSE	
Improper starting procedure used.	Check with the customer to determine if proper starting procedure is used, as outlined in the owner's manual.
No fuel in gas tank	Add fuel. Check fuel gauge for proper operation.
Choke valve not closing sufficiently when cold.	Adjust the choke thermostatic coil. <u>Use procedure H or I.</u>
Choke valve or linkage binding or sticking.	Realign the choke valve or linkage as necessary. If caused by dirt and gum, clean with automatic choke cleaner. <u>Do not oil choke linkage.</u> If parts are replaced, check adjustments using procedure D, E or F.
No fuel in carburetor.	<ol style="list-style-type: none"> <li>1. Remove fuel line at carburetor. Connect hose to fuel line and run into metal container. Remove the high tension coil wire from center tower on distributor cap and ground. Crank over engine — if there is no fuel discharge from the fuel line, check for kinked or bent lines. Disconnect fuel line at tank and blow out with air hose, reconnect line and check again for fuel discharge. If none, replace fuel pump. Check pump for adequate flow, as outlined in service manual.</li> <li>2. If fuel supply is o.k., check the following:               <ol style="list-style-type: none"> <li>a. Inspect fuel filters. If plugged replace.</li> <li>b. If filters are o.k., remove air horn and check for a bind in the float mechanism or a sticking float needle. If o.k., adjust float as specified. <u>Use procedure A.</u></li> </ol> </li> </ol>
Engine Flooded. NOTE: To check for flooding, remove the air cleaner, with the engine off, and look into the carburetor bores. Fuel will be dripping off nozzles and/or the carburetor will be very wet.	Check to determine if customer is using proper carburetor unloading procedure. Depress the accelerator to the floor and check the carburetor to determine if the choke valve is opening. If not, adjust the throttle linkage and unloader, as specified. <u>Use procedure G.</u>
Carburetor flooding	NOTE: Before removing the carburetor air horn, use the following procedure which may eliminate the flooding. <ol style="list-style-type: none"> <li>1. Remove the fuel line at the carburetor and plug. Crank and run the engine until the fuel bowl runs dry. Turn off the engine and connect fuel line. Then re-start and run engine. This will usually flush dirt past the carburetor float needle and seat.</li> <li>2. If dirt is in fuel system, clean the system and replace fuel filters as necessary. If excessive dirt is found, remove the carburetor unit. Disassemble and clean.</li> </ol>

## ROCHESTER CARBURETOR DIAGNOSIS — MODELS M, MV

POSSIBLE CAUSE	CORRECTIVE ACTION
Carburetor flooding (continued)	<ol style="list-style-type: none"> <li>3. Check float needle and seat for proper seal. If a needle and seat tester is not available, apply mouth suction to the needle seat with needle installed. If the needle is defective, replace with a factory matched set.</li> <li>4. Check float for being loaded with fuel, bent float hanger or binds in the float arm.</li> </ol> <p>NOTE: A solid float can be checked for fuel absorption by lightly squeezing between fingers. If wetness appears on surface or float feels heavy (Check with known good float), replace the float assembly.</p> <ol style="list-style-type: none"> <li>5. Adjust float. <u>Use procedure A.</u></li> </ol>

**Problem:** ENGINE STARTS AND STALLS

Engine does not have enough fast idle speed when cold.	Check and re-set the fast idle setting and fast idle cam. <u>Use procedure C and D.</u>
Choke vacuum break unit is not adjusted to specification or unit is defective.	<ol style="list-style-type: none"> <li>1. Adjust vacuum break to specification. <u>Use procedure E or F.</u></li> <li>2. If adjusted O.K., check the vacuum break for proper operation as follows: On the externally mounted vacuum break unit, connect a piece of hose to the nipple on the vacuum break unit and apply suction by mouth or use tool J-23417 to apply vacuum. Plunger should move inward and hold vacuum. If not, replace the unit. On the integral vacuum break unit remove cover and visually check diaphragm and vacuum channel. If diaphragm is leaking, replace.</li> </ol> <p>NOTE: Always check the fast idle cam adjustment before adjusting vacuum break unit. <u>Use procedure D.</u></p>
Choke coil rod out of adjustment.	Adjust choke coil rod. <u>Use procedure H or I.</u>
Choke valve and/or linkage sticking or binding.	<ol style="list-style-type: none"> <li>1. Clean and align choke valve and linkage. Replace if necessary.</li> <li>2. Re-adjust if part replacement is necessary. <u>Use procedure D, E or F.</u></li> </ol>
Idle speed setting	Adjust idle speed to specifications on decal in engine compartment.
Not enough fuel in carburetor.	<ol style="list-style-type: none"> <li>1. Check fuel pump pressure and volume.</li> <li>2. Check for partially plugged fuel inlet filter. Replace if dirty.</li> <li>3. Remove air horn and check float adjustments. <u>Use procedure A.</u></li> </ol>
Carburetor flooding. NOTE: Check by using procedure outlined under carburetor flooding, Page 1.	<ol style="list-style-type: none"> <li>1. Check float needle and seat for proper seal. If a needle and seat tester is not available, mouth suction can be applied to the needle seat with needle installed. If needle is defective, replace with a factory matched set.</li> <li>2. Check float for being loaded with fuel, bent float hanger or binds in the float arm.</li> </ol>

## 6M-42 ENGINE FUEL

### ROCHESTER CARBURETOR DIAGNOSIS — MODELS M, MV

POSSIBLE CAUSE	CORRECTIVE ACTION
Carburetor flooding (continued)	<p>NOTE: A solid float can be checked for fuel absorption by lightly squeezing between fingers. If wetness appears on surface or float feels heavy (check with known good float, replace the float assembly.</p> <ol style="list-style-type: none"> <li>3. Check float adjustments. <u>Use procedure A.</u></li> <li>4. If excessive dirt is found in the carburetor, clean the fuel system and carburetor. Replace fuel filters as necessary.</li> </ol>

## Problem: ENGINE IDLES ROUGH AND STALLS

Idle speed setting.	Re-set idle speed per instructions on decal in engine compartment.
Manifold vacuum hoses disconnected or improperly installed.	Check all vacuum hoses leading into the manifold or carburetor base for leaks or being disconnected. Install or replace as necessary.
Carburetor loose on intake manifold.	Torque carburetor to manifold bolts (10-14 ft. lbs.).
Intake manifold is loose or gaskets are defective.	Using a pressure oil can, spray light oil or kerosene around manifold legs and carburetor base. If engine RPM changes, tighten or replace the manifold gaskets or carburetor base gaskets as necessary.
Hot idle compensator not operating (where used.)	Normally the hot idle compensator should be closed when engine is running cold and open when engine is hot (approx. 140°F at comp.) replace if defective.
Carburetor flooding. NOTE: Check by using procedure outlined under "carburetor flooding", page 1.	<ol style="list-style-type: none"> <li>1. Remove air horn and check float adjustment. <u>Use procedure A.</u></li> <li>2. Check float needle and seat for proper seal. If a needle and seat tester is not available, mouth suction can be applied to the needle seat with needle installed. If the needle is defective, replace with a factory matched set.</li> <li>3. Check float for being loaded with fuel, bent float hanger or binds in the float arm.</li> </ol> <p>NOTE: A solid float can be checked for fuel absorption by lightly squeezing between fingers. If wetness appears on surface or float feels heavy (check with known good float), replace the float assembly.</p> <ol style="list-style-type: none"> <li>4. If excessive dirt is found in the carburetor, clean the fuel system and carburetor. Replace fuel filters as necessary.</li> </ol>

## Problem: ENGINE HESITATES ON ACCELERATION

Defective accelerator pump system  NOTE: A quick check of the pump system can be made as follows. With the engine off, remove air cleaner and look into the carburetor bores and observe pump stream, while briskly opening throttle valve. A full stream of fuel should emit from pump jet and strike near the center of the venturi area.	<ol style="list-style-type: none"> <li>1. Remove air horn and check pump cup. If cracked, scored or distorted, replace the pump plunger.</li> <li>2. Check the pump discharge ball for proper seating and location. The pump discharge ball is located in a cavity next to the pump well. To check for proper seating, remove air horn and gasket and fill cavity with fuel. No "leak down" should occur. Restake and replace check ball if leaking. Make sure discharge ball, spring, and retainer are properly installed.</li> </ol>
---	--

## ROCHESTER CARBURETOR DIAGNOSIS — MODELS M, MV

POSSIBLE CAUSE	CORRECTIVE ACTION
Dirt in pump passages or pump jet.	Clean and Blow out with compressed air.
Fuel level.	Check for sticking float needle or binding float. Free up or replace parts as necessary. Check and reset float level to specification. <u>Use procedure A.</u>
Leaking air horn to float bowl gasket.	Torque air horn to float bowl using proper tightening procedure. <u>Use procedure J.</u>
Carburetor loose on manifold.	Torque carburetor to manifold bolts. (10-14 ft. lbs.).

**Problem:** NO POWER ON HEAVY ACCELERATION  
OR AT HIGH SPEED

Carburetor throttle valve not going wide open. (Check by pushing accelerator pedal to floor).	Adjust throttle linkage to obtain wide open throttle in carburetor.
Dirty or plugged fuel filters.	Replace with a new filter element.
Power system not operating.	Check power piston for free up and down movement. If power piston is sticking check power piston and cavity for dirt, or scores. Check power piston spring for distortion. Clean or replace as necessary.
Metering rod not adjusted to specification.	Adjust metering rod. <u>Use procedure B.</u>
Float level too low.	1. Check and reset float level to specification. <u>Use procedure A.</u>
Float not dropping far enough into float bowl.	Check for binding float hanger and for proper float alignment in float bowl.
Main metering jet or metering rod dirty, plugged or incorrect part.	<ol style="list-style-type: none"> <li>1. If the main metering jets are plugged or dirty and excessive dirt is in the fuel bowl. The carburetor should be completely disassembled and cleaned.</li> <li>2. Check the jet or rod for being the correct part. Consult the parts list for proper usage. The last two digits stamped on the jet face are the same as the last two digits of the part number. The metering jet and rod can be identified using chart. <u>Use procedure K.</u></li> </ol>

**Problem:** ENGINE STARTS HARD WHEN HOT

Choke valve not opening completely.	<ol style="list-style-type: none"> <li>1. Check for binding choke valve and/or linkage. Clean and free-up or replace parts as necessary. <u>Do not oil choke linkage.</u></li> <li>2. Check and adjust choke thermostatic coil. <u>Use procedure H or I.</u></li> </ol>
Engine flooded - Carburetor flooding.	See procedure under "Engine cranks, will not start". Pg. 1
No fuel in carburetor.	<ol style="list-style-type: none"> <li>1. Check fuel pump. Run pressure and volume test.</li> <li>2. Check float needle for sticking in seat, or binding float.</li> </ol>
Leaking float bowl.	Fill bowl with fuel and look for leaks.

**Problem:** ENGINE RUNS UNEVEN OR SURGES

POSSIBLE CAUSE	CORRECTIVE ACTION
Fuel Restriction	Check all hoses and fuel lines for bends, kinks or leaks. Straighten and secure in position. Check all fuel filters. If plugged or dirty - replace.
Dirt or water in fuel system.	Clean fuel tank and lines. Remove and clean carburetor.
Fuel level	Adjust float. <u>Use procedure A.</u> Check for free float and float needle valve operation.
Main metering rod not adjusted to specification.	Remove carburetor air horn and gasket. Adjust metering rod. <u>Use procedure B.</u>
Metering rod bent or incorrect part. Main metering jet defective, loose or incorrect part.	Replace as necessary. See identification chart. <u>Use procedure B and K.</u>
Power system in carburetor not functioning properly. Power valve or piston sticking in down position.	Free up or replace as necessary.
Vacuum leakage	It is absolutely necessary that all vacuum hoses and gaskets are properly installed, with no air leaks. The carburetor and manifold should be evenly tightened to specified torque.

**Problem:** POOR FUEL ECONOMY

Engine needs complete tune-up.	Check engine compression. Examine spark plugs, (if dirty or improperly gapped, clean and re-gap or replace). Check ignition point dwell, condition, readjust ignition points if necessary and check and reset ignition timing. Clean or replace air cleaner element if dirty. Check for restricted exhaust system and intake manifold for leakage, make sure all vacuum hoses are connected correctly. Make sure T.C.S. valve is operating properly.
Choke valve not fully opening.	1. Clean choke and free up linkage. 2. Check choke coil for proper adjustment. Reset to specifications. <u>Use procedure H or I.</u>
Fuel leaks.	Check fuel tank, fuel lines and fuel pump for any fuel leakage.
Main metering rod not adjusted to specification.	Remove carburetor air horn and gasket. Adjust metering rod. <u>Use procedure B.</u>
Metering rod bent or incorrect part. Main metering jet defective, loose or incorrect part.	Replace as necessary. See identification chart. <u>Use procedure B and K.</u>
Power system in carburetor not functioning properly. Power valve or piston sticking in up position.	Free up or replace as necessary.
High fuel level in carburetor or carburetor flooding.	1. Check for dirt in the needle and seat. Test using suction by mouth or needle seat tester. If defective, replace needle and seat assembly with factory matched set. 2. Check for loaded float. 3. Re-set carburetor float to specifications. <u>Use procedure A.</u> 4. If excessive dirt is present in the carburetor bowl, the carburetor should be cleaned.

## ROCHESTER CARBURETOR DIAGNOSIS — MODELS M, MV

POSSIBLE CAUSE	CORRECTIVE ACTION
Fuel being pulled from accelerator system into venturi through pump jet.	Run engine at RPM where nozzle is feeding fuel. Observe pump jet. If fuel is feeding from jet, check pump discharge ball for proper seating by filling cavity above ball with fuel to level of casting. No "leak down" should occur with discharge ball in place. Re-stake or replace leaking check ball, defective spring, or retainer.
Air bleeds or fuel passages in carburetor dirty or plugged.	Clean carburetor or overhaul as necessary.

Classiccarlibrary.com

**A**

② WITH GASKET REMOVED, GAUGE FROM TOP OF CASTING TO TOP OF INDEX POINT AT TOE OF FLOAT

① HOLD FLOAT RETAINING PIN FIRMLY IN PLACE — PUSH DOWN ON END OF FLOAT ARM, AGAINST TOP OF FLOAT NEEDLE

③ BEND HERE TO ADJUST FLOAT UP OR DOWN

**FLOAT LEVEL ADJUSTMENT**

**B**

③ HOLD POWER PISTON DOWN AND SWING METERING ROD HOLDER OVER FLAT SURFACE (GASKET REMOVED) OF BOWL CASTING NEXT TO CARBURETOR BORE

⑤ BEND HERE TO ADJUST

BENDING TOOL

④ SPECIFIED PLUG GAUGE — SLIDE FIT

① REMOVE METERING ROD BY HOLDING THROTTLE VALVE WIDE OPEN. PUSH DOWNWARD ON METERING ROD AGAINST SPRING TENSION, THEN SLIDE METERING ROD OUT OF SLOT IN HOLDER AND REMOVE FROM MAIN METERING JET.

② BACK OUT IDLE SPEED SCREW AND IDLE STOP SOLENOID — HOLD THROTTLE VALVE COMPLETELY CLOSED

**METERING ROD ADJUSTMENT**

**C**

③ INSERT SCREWDRIVER IN SLOT IN CAM FOLLOWER. BEND FOLLOWER IN OR OUT TO ADJUST.

② PLACE CAM FOLLOWER ON HIGH STEP OF CAM

① ADJUST CURB IDLE SPEED WITH IDLE SPEED SCREW OR IDLE STOP SOLENOID (SEE DECAL)

MANUAL CHOKE MODEL ROTATE SMOOTH CAM TO HIGHEST POSITION

**FAST IDLE ADJUSTMENT**

**D**

③ GAUGE BETWEEN LOWER EDGE OF CHOKE VALVE AND INSIDE AIR HORN WALL

② HOLD DOWN ON CHOKE VALVE WITH ROD IN END OF SLOT

④ BEND ROD TO ADJUST

① WITH FAST IDLE ADJUSTMENT MADE, CAM FOLLOWER MUST BE HELD FIRMLY ON SECOND STEP OF FAST IDLE CAM AGAINST HIGH STEP

NOTE: MANUAL CHOKE MODELS WITH SMOOTH CONTOUR CAM.

USE THE SAME PROCEDURE AS ABOVE EXCEPT FOR STEP (1). AS THERE ARE NO STEPS ON MANUAL CHOKE CAM, THE INDEX LINE ON SIDE OF CAM SHOULD BE LINED UP WITH CONTACT POINT OF THE FAST IDLE CAM FOLLOWER TANG.

**FAST IDLE CAM ADJUSTMENT (CHOKE ROD)**

**E**

④ PLACE GAUGE BETWEEN LOWER EDGE OF CHOKE VALVE AND AIR HORN WALL

⑤ BEND ROD TO ADJUST

③ ROD IN END OF SLOT

② DIAPHRAGM PLUNGER IN UNTIL IT SEATS

① USE OUTSIDE VACUUM SOURCE TO SEAT DIAPHRAGM

**VACUUM BREAK ADJUSTMENT STANDARD — 6 CYL.**



SERVICE PROCEDURES — MODELS M, MV

**F**

**VACUUM BREAK ADJUSTMENT  
4 CYL.**

**G**

**UNLOADER**

**H**

**CHOKE COIL ROD ADJUSTMENT  
CHOKE COIL ROD ADJUSTMENT  
STANDARD — 6 CYL.**

**I**

**CHOKE COIL ROD ADJUSTMENT  
4 CYL.**

**J**

**AIR HORN TIGHTENING SEQUENCE**

**K**

### MAIN METERING JETS

The main metering jet used in the single bore Monojet differs from other models and should not be interchanged. It can be identified by 5 radial lines which are stamped opposite the identification number on the jet face.

Example:

The number stamped on the jet face indicates the orifice size. It can be two or three digits dependent upon the size of the orifice. The jet size can be determined by subtracting 100 from the last three digits of the part number.

Part No.	Stamped On Jet	Part No.	Stamped On Jet
7034192	92	7034204	104
7034195	95	7034205	105
7034198	98	7034206	106

### MAIN METERING RODS

The metering rod used in the Monojet carburetor can be identified as follows. A three digit number is stamped on the shank of the metering rod in the area shown. The number denotes the diameter of the rod at Point "A".

Example:

DIAMETER "A"  
Stamped No. 060      Diameter "A" .060"

## ROCHESTER CARBURETOR DIAGNOSIS MODELS 2G, 2GV — TWO BARREL

### Problem:

ENGINE CRANKS (TURN OVER)  
WILL NOT START OR STARTS HARD WHEN COLD

POSSIBLE CAUSE	CORRECTIVE ACTION
Improper starting procedure used.	Check with the customer to determine if proper starting procedure is used, <u>as outlined</u> in the owner's manual.
No fuel in gas tank.	Add fuel. Check fuel gauge for proper operation.
Choke valve not closing sufficiently when cold.	Adjust the choke thermostatic coil. <u>Use procedure J or K.</u>
Choke valve or linkage binding or sticking.	Realign the choke valve or linkage as necessary. If caused by dirt and gum, clean with automatic choke cleaner. <u>Do not oil choke linkage.</u> If parts are replaced, check adjustments using procedure D, E or F.
No fuel in carburetor.	<ol style="list-style-type: none"> <li>1. Remove fuel line at carburetor. Connect hose to fuel line and run into metal container. Remove the high tension coil wire from center tower on distributor cap and ground. Crank over engine - if there is no fuel discharge from the fuel line, check for kinked or bent lines. Disconnect fuel line at tank and blow out with air hose, reconnect line and check again for fuel discharge. If none, replace fuel pump. Check pump for adequate flow as outlined in service manual.</li> <li>2. If fuel supply is o.k., check the following.               <ol style="list-style-type: none"> <li>a. Inspect fuel filters. If plugged, replace.</li> <li>b. If filters are o.k., remove air horn and check for a bind in the float mechanism or a sticking float needle. If o.k., adjust float as specified. <u>Use procedure A and B or C and D.</u></li> </ol> </li> </ol>
Engine flooded.  NOTE: To check for flooding, remove the air cleaner, with the engine off, and look into the carburetor bores. Fuel will be dripping off nozzles and the carburetor bores will be very wet.	<p>Check to determine if customer is using proper carburetor unloading procedure. Depress the accelerator to the floor and check the carburetor to determine if the choke valve is opening. If not, adjust the throttle linkage and unloader, as specified. <u>Use procedure I.</u></p> <p>If choke unloader is operating properly, check for carburetor flooding.</p> <p>NOTE: Before removing the carburetor air horn use the following procedure which may eliminate the flooding. Remove the fuel line at the carburetor and plug. Crank and run the engine until the fuel bowl runs dry. Turn off the engine and connect fuel line. Then re-start and run engine. This will usually flush dirt past the carburetor float needle and seat. If dirt is in fuel system, clean the system and replace fuel filters as necessary. If excessive dirt is found, remove the carburetor unit, disassemble and clean. Check float needle and seat for proper seal. If a needle and seat tester is not available, apply mouth suction to the needle seat with needle installed. If the needle or seat is defective, replace with a factory matched set. Check float for being loaded with fuel, bent float hanger or binds in the float arm.</p> <p>NOTE: A solid float can be checked for fuel absorption by lightly squeezing between fingers. If wetness appears on surface or float feels heavy (check with known good float), replace the float assembly. Check metal float for leakage by shaking. Adjust float. <u>Use procedure A and B or C and D.</u></p>

## ROCHESTER CARBURETOR DIAGNOSIS – MODELS 2G, 2GV – TWO BARREL

**Problem:** ENGINE STARTS AND STALLS

POSSIBLE CAUSE	CORRECTIVE ACTION
Engine does not have enough fast idle speed when cold.	Check and re-set the idle stop screw and fast idle cam. Use procedure F.
Choke vacuum break unit is not adjusted to specification or is defective.	Adjust vacuum break assembly to specification. Use procedure G or H.  If adjusted O.K., check the vacuum break unit for proper operation as follows: Connect a piece of hose to the nipple on the vacuum break unit and apply suction by mouth or use vacuum source to apply vacuum. Plunger should move inward and hold vacuum. If not, replace the unit.
Choke coil rod out of adjustment.	Adjust choke coil rod. Use procedure J or K.
Choke valve and/or sticking or binding.	Clean and align choke valve and linkage. Replace if necessary. Re-adjust if part replacement is necessary. Use procedures F, G and H.
Idle speed setting	Adjust idle speed to specifications on decal in engine compartment.
Not enough fuel in carburetor.	Check fuel pump pressure and volume. Check for partially plugged fuel inlet filter. Replace if dirty. Check the float mechanism for binds or not enough float drop. Adjust as specified. Use procedure B or D.
Carburetor flooding.  NOTE: Check by using procedure outlined under carburetor flooding. Page 1.	<ol style="list-style-type: none"> <li>1. Check float needle and seat for proper seal. If a needle and seat tester is not available, mouth suction can be applied to the needle seat with needle installed. If needle is defective, replace with a factory matched set.</li> <li>2. Check float for being loaded with fuel, bent float hanger or binds in the float arm.  NOTE: A solid float can be checked for fuel absorption by lightly squeezing between fingers. If wetness appears on surface or float feels heavy (check with known good float, replace the float assembly).</li> <li>3. Check float adjustments. Use procedure A and B or C and D.</li> <li>4. If excessive dirt is found in the carburetor, clean the fuel system and carburetor. Replace fuel filters as necessary.</li> </ol>

**Problem:** ENGINE IDLES ROUGH AND STALLS

Idle speed setting	Re-set idle speed per instructions on decal in engine compartment.
Manifold vacuum hoses disconnected or improperly installed.	Check all vacuum hoses leading into the manifold or carburetor base for leaks or being disconnected. Install or replace as necessary.
Carburetor loose on intake manifold.	Torque carburetor to manifold bolts (10-14 ft. lbs.).
Intake manifold is loose or gaskets are defective.	Using a pressure oil can, spray light oil or kerosene around manifold legs and carburetor base. If engine RPM changes, tighten or replace the manifold gaskets or carburetor base gaskets as necessary.

## ROCHESTER CARBURETOR DIAGNOSIS – MODELS 2G, 2GV – TWO BARREL

**Problem:** ENGINE IDLES ROUGH  
AND STALLS (CONTINUED)

POSSIBLE CAUSE	CORRECTIVE ACTION
Carburetor flooding. NOTE: Check by using procedure outlined under engine flooded. <u>See page 1.</u>	Remove air horn and check float adjustments. <u>Use procedure A and B or C and D.</u> If excessive dirt is found in the carburetor, clean the fuel system and carburetor. Replace fuel filters as necessary. Check float needle and seat for proper seal. If a needle and seat tester is not available, mouth suction can be applied to the needle seat with needle installed. If the needle is defective, replace with a factory matched set. Check float for being loaded with fuel, bent float hanger or binds in the float arm. NOTE: A solid float can be checked for fuel absorption by lightly squeezing between fingers. If wetness appears on surface or float feels heavy (check with known good float, replace the float assembly). Check metal float for leakage by shaking.

**Problem:** ENGINE HESITATES ON ACCELERATION

Accelerator pump not adjusted to specification.	Adjust accelerator pump. <u>Use procedure E.</u>
Defective accelerator pump system. Note: A quick check of the pump system can be made as follows. With the engine off, look into the carburetor bores, and observe pump shooters, while briskly opening throttle valves. A full stream of fuel should emit from each pump jet and squirt into the venturi area.	Remove air horn and check pump cup. If cracked, scored or distorted, remove the pump plunger. Check the pump discharge ball for proper seating and location. The pump discharge ball is 3/16" steel and is located beneath the venturi cluster assembly. Check pump discharge ball for proper seating by filling cavity above ball with fuel to level of casting. No "leak down" should occur with discharge ball, spring and retainer in place. Re-stake or replace check ball if leaking
Dirt in pump passages.	Clean and blow out with compressed air.
Float level.	Check for sticking float needle or binding float. Free up or replace parts as necessary. Check and reset float level and drop to specification. <u>Use procedure A and B or C and D.</u>
Carburetor loose on manifold.	Torque carburetor to manifold bolts (10-14 ft. lbs.).

**Problem:** NO POWER ON HEAVY ACCELERATION OR AT HIGH SPEED

Carburetor throttle valves not going wide open. (Check by pushing accelerator pedal to floor).	Adjust throttle linkage to obtain wide open throttle in carburetor.
Dirty or plugged fuel filters.	Replace with a new filter element.

## ROCHESTER CARBURETOR DIAGNOSIS – MODELS 2G, 2GV – TWO BARREL

**Problem:** NO POWER ON HEAVY ACCELERATION  
OR AT HIGH SPEED (CONTINUED)

POSSIBLE CAUSE	CORRECTIVE ACTION
Float level too low.	Check and reset float level to specification. <u>Use procedure A or C.</u>
Float not dropping far enough into float bowl.	Check and adjust float drop to specification. <u>Use procedure B or D.</u>
Main metering jets or venturi cluster dirty, plugged or incorrect part.	If the main metering jets are plugged or dirty and excessive dirt is in the fuel bowl, the carburetor should be completely disassembled and cleaned. If the jets are incorrect size consult the parts list for proper usage. The last two digits stamped on the jet face are the same as the last two digits of the part number. <u>See Chart M.</u>

**Problem:** ENGINE STARTS HARD  
WHEN HOT

Choke valve not opening completely.	Check for binding choke valve and linkage. Clean or replace as necessary. <u>Do not oil choke linkage.</u> Check and adjust choke thermostatic coil. <u>Use procedure J or K.</u>
Engine flooded. - Carburetor flooding.	See procedure under "Engine cranks, will not start - Engine flooded." Page 1.
No fuel in carburetor.	Check fuel pump. Run pressure and volume test. Check for plugged inlet filter. Clean or replace as necessary. Check float needle for sticking in seat, or binding float.
Leaking float bowl.	Fill bowl with fuel and look for leaks.

**Problem:** ENGINE RUNS UNEVEN  
OR SURGES.

Fuel restriction.	Check all hoses and fuel lines for bends, kinks or leaks. Straighten and secure in position. Check all fuel filters. If plugged or dirty - replace.
Dirt or water in fuel system.	Clean fuel tank, lines and filters. Remove and clean carburetor.
Fuel level.	Adjust float. <u>Use procedure A and B, or D and C.</u> Check for free float and float needle valve operation. Free up or replace as necessary.
Air bleeds or fuel passages in carburetor, dirty or plugged.	Clean carburetor or overhaul as necessary.
Main metering jet defective, loose or incorrect part.	Replace as necessary. <u>See identification chart M.</u>
Power system in carburetor not functioning properly. Power valve or piston sticking.	Free up or replace as necessary.
Vacuum Leakage.	It is absolutely necessary that all vacuum hoses and gaskets are properly installed with no air leaks. The carburetor and manifold should be evenly tightened to specified torque.

## ROCHESTER CARBURETOR DIAGNOSIS – MODELS 2G, 2GV – TWO BARREL

**Problem:** ENGINE RUNS UNEVEN  
OR SURGES (CONTINUED)

POSSIBLE CAUSE	CORRECTIVE ACTION
Engine needs complete tune up.	Check engine compression, examine spark plugs, (if dirty or improperly gapped, clean and re-gap or replace), ignition point dwell, condition, re-adjust ignition points if necessary and check and reset ignition timing. Clean or replace air cleaner element if dirty. Check for restricted exhaust system and intake manifold for leakage. Make sure all vacuum hoses are connected.
Choke valve staying partially closed when engine is warm.	Clean choke and free up linkage. Check choke coil for proper adjustment. Reset to specifications. <u>Use procedure J or K.</u>
Fuel leaks.	Check fuel tank, fuel lines and fuel pump for any fuel leakage.
High fuel level in carburetor.	Check for dirt in the needle and seat. Test using suction by mouth or needle seat tester. Check for loaded or leaking float. Re-set carburetor float to specifications. <u>Use procedure A or C.</u> If excessive dirt is present in the carburetor bowl, the carburetor should be cleaned.
Power system in carburetor not functioning properly. A. Power piston sticking. B. Power valve leaking, loose, or stuck open.	A. Free up or replace as necessary. B. Tighten, free up or replace as necessary.
Wrong main metering jets installed.	Consult parts list for proper jet. The last two digits of the part number appear on the jet face. <u>See chart M.</u>
Fuel being pulled from accelerator system into venturi through pump jets.	Run engine at RPM where nozzles are feeding fuel. Observe pump jets. If fuel is feeding from jets, check the pump discharge ball, spring and retainer. Check pump discharge ball for proper seating by filling cavity above ball with fuel to level of casting. No "leak down" should occur with discharge ball, spring and retainer in place. Re-stake or replace leaking check ball.
Air bleeds or fuel passages in carburetor dirty or plugged.	Clean carburetor or overhaul as necessary.

SERVICE PROCEDURES – MODELS 2G, 2GV – TWO BARREL

**A**

- 1 INVERT AIR HORN WITH GASKET IN PLACE.
- 2 GAUGE FROM END OF FLOAT AT LOWER EDGE OF SEAM TO AIR HORN GASKET
- 3 BEND HERE TO ADJUST
- 4 VISUALLY CHECK FLOAT ALIGNMENT

**FLOAT LEVEL ADJUSTMENT**

**B**

- 1 AIR HORN RIGHT SIDE UP TO ALLOW FLOAT TO HANG FREE
- 2 MEASURE SPECIFIED DISTANCE FROM GASKET SURFACE TO BOTTOM OF FLOAT
- 3 BEND FLOAT TANG TO ADJUST FOR PROPER SETTING
- 4 NEEDLE MUST NOT WEDGE AT MAXIMUM DROP

**FLOAT DROP ADJUSTMENT**

**C**

- 1 INVERT AIR HORN WITH GASKET IN PLACE
- 2 MEASURE FROM LIP AT TOE OF FLOAT TO AIR HORN GASKET
- 3 BEND HERE TO ADJUST
- 4 VISUALLY CHECK FLOAT ALIGNMENT

**FLOAT LEVEL ADJUSTMENT**

**D**

- 1 AIR HORN RIGHT SIDE UP TO ALLOW FLOAT TO HANG FREE (GASKET IN PLACE)
- 2 MEASURE SPECIFIED DISTANCE FROM GASKET SURFACE TO NOTCH AT TOE OF FLOAT
- 3 BEND FLOAT TANG TO ADJUST FOR PROPER SETTING
- 4 NEEDLE MUST NOT WEDGE AT MAXIMUM DROP

**FLOAT DROP ADJUSTMENT**

**E**

- 3 MEASURE FROM TOP OF AIR HORN RING TO TOP OF PUMP ROD
- 1 BACK OUT IDLE SCREW
- 2 THROTTLE VALVES MUST BE FULLY CLOSED
- 4 BEND PUMP ROD TO ADJUST

**PUMP ROD ADJUSTMENT**

**F**

- 2 SPECIFIED GAUGE BETWEEN UPPER EDGE OF CHOKE VALVE AND WALL OF AIR HORN
- 3 BEND TANG TO ADJUST
- 1 FAST IDLE SCREW ON SECOND STEP OF CAM AGAINST HIGH STEP

H - HIGHEST STEP  
2 - 2ND STEP

**FAST IDLE CAM ADJUSTMENT (CHOKE ROD)**

**G**

- 3 PLACE GAUGE BETWEEN UPPER EDGE OF CHOKE VALVE AND AIR HORN WALL
- 2 HOLD CHOKE VALVE CLOSED WITH ROD IN BOTTOM OF SLOT
- 1 SEAT DIAPHRAGM PLUNGER USING OUTSIDE VACUUM SOURCE
- 4 BEND ROD TO ADJUST

**VACUUM BREAK ADJUSTMENT (V-8)**

**6M-54 ENGINE FUEL  
SERVICE PROCEDURES – MODELS 2G, 2GV – TWO BARREL**

**H**

③ PLUNGER MUST BE FULLY EXTENDED (BUCKING SPRING COMPRESSED)

⑤ GAUGE BETWEEN UPPER EDGE OF CHOKE VALVE AND WALL OF AIR HORN

④ PUSH UP ON LEVER UNTIL ROD IN BOTTOM OF SLOT

⑥ BEND ROD TO ADJUST

① PLACE IDLE SCREW ON HIGHEST STEP OF FAST IDLE CAM

② SEAT VACUUM DIAPHRAGM USING OUTSIDE VACUUM SOURCE

CAUTION: USE CARE WHEN COMPRESSING PLUNGER SPRING SO AS NOT TO PULL VACUUM DIAPHRAGM OFF ITS SEAT.

**VACUUM BREAK ADJUSTMENT  
4 CYL. -**

**K**

④ TOP EDGE OF ROD OR PIN ON SWIVEL SHOULD BE IN SPECIFIED LOCATION

② HOLD CHOKE VALVE WIDE OPEN

① REMOVE UPPER END OF ROD FROM CHOKE LEVER

③ PUSH DOWN ON ROD TO END OF TRAVEL

**CHOKE COIL ROD ADJUSTMENT  
4 CYL. -**

**I**

② GAUGE BETWEEN UPPER EDGE OF CHOKE VALVE AND AIR HORN CASTING

① HOLD THROTTLE VALVES WIDE OPEN

③ BEND TANG TO ADJUST

**UNLOADER ADJUSTMENT**

**L**

**AIR HORN TIGHTENING SEQUENCE**

**J**

② HOLD CHOKE VALVE WIDE OPEN

① REMOVE UPPER END OF ROD FROM CHOKE LEVER

④ ROD SHOULD FIT IN BOTTOM OF SLOT IN LEVER

⑤ TO ADJUST, BEND LEVER WITH SCREWDRIVER IN SLOT

③ PUSH DOWN ON ROD TO END OF TRAVEL

**CHOKE COIL ROD ADJUSTMENT  
(V-8)**

**M**

**METERING JETS**

**PART NUMBERING INFORMATION**

The last two digits of the part number indicates the orifice size. These two numbers are stamped on the face of the jet.

There are three types or groups of main metering jets used in the 2G, 2GV carburetors.

"GROUP A" METERING JETS 90° SQUARE APPROACH (ZINC PLATE)	"GROUP B" METERING JETS 60° APPROACH (SMALL)	"GROUP C" METERING JETS 60° APPROACH (LARGE)
<b>Part Numbers</b>		
Group A	7002943 – 7002969	
Group B	7002639 – 7002660	
Group C	7008660 – 7008688	



# ROCHESTER CARBURETOR DIAGNOSIS

## ALL MODELS 4M, 4MV — FOUR BARREL

**Problem:** ENGINE CRANKS (TURNS OVER) WILL NOT START OR STARTS HARD WHEN COLD

POSSIBLE CAUSE	CORRECTIVE ACTION
Improper starting procedure used.	Check with the customer to determine if proper starting procedure is used, <u>as outlined in the owner's manual.</u>
No fuel in gas tank.	Add fuel. Check fuel gauge for proper operation.
Choke valve not closing sufficiently when cold.	Adjust the choke thermostatic coil. <u>Use procedure G.</u>
Choke valve or linkage binding or sticking.	Realign the choke valve or linkage as necessary. If caused by dirt and gum, clean with automatic choke cleaner. <u>Do not oil choke linkage.</u> If parts are replaced, check adjustments <u>using procedures C, D, and E.</u>
Vacuum leaks in carburetor base or intake manifold.	Check all manifold vacuum hoses for being connected and in proper location. Check manifold and carburetor base gaskets for leaks. Tighten or replace as necessary. Torque carburetor to manifold nuts 10-14 ft. lbs.
No fuel in carburetor.	<ol style="list-style-type: none"> <li>1. Remove fuel line at carburetor. Connect hose to fuel line and run into metal container. Remove the high tension coil wire from center tower on distributor cap and ground. Crank over engine - if there is no fuel discharge from the fuel line, check for kinked or bent lines. Disconnect fuel line at tank and blow out with air hose, reconnect line and check again for fuel discharge. If none, replace fuel pump. Check pump for adequate flow as outlined in service manual.</li> <li>2. If fuel supply is o.k., check the following.               <ol style="list-style-type: none"> <li>a. Inspect fuel filters. If plugged, replace.</li> <li>b. If filters are o.k., remove air horn and check for a bind in the float mechanism or a sticking float needle. If o.k., adjust float as specified. <u>Use procedure A.</u></li> </ol> </li> </ol>
Engine flooded.  NOTE: To check for flooding, remove air cleaner with engine off, and look into carburetor bores. Fuel will be dripping off discharge nozzles and carburetor bores will be very wet.	<ol style="list-style-type: none"> <li>1. Check to determine if customer is using proper carburetor unloading procedure. Depress the accelerator to the floor and check carburetor to determine if the choke valve is opening. If not, adjust throttle linkage and unloader as specified. <u>Use procedure F.</u></li> <li>2. If choke unloader is working properly - check for carburetor flooding.  NOTE: Before removing the carburetor air horn, use the following procedure which may eliminate the flooding.  Remove the fuel line at carburetor and plug. Start and run the engine until the fuel bowl runs dry. Turn off engine and connect fuel line. Then restart and run engine. This will usually flush dirt past the carburetor float needle and seat.</li> <li>3. If dirt is in the fuel system, clean the system and replace fuel filters as necessary. If excessive dirt is found, remove the carburetor unit. Disassemble and clean.</li> <li>4. Check float needle and seat for proper seal. If a needle and seat tester is not available, apply mouth suction needle seat with needle installed. If needle and seat is defective, replace with factory matched set.</li> </ol>

**Problem:** ENGINE CRANKS (TURNS OVER)  
WILL NOT START OR STARTS HARD WHEN COLD (Cont.)

POSSIBLE CAUSE	CORRECTIVE ACTION
Engine flooded. (continued)	<p>5. Check float for being loaded with fuel, bent float arm or binds in the float hanger. Free up or replace parts as necessary.</p> <p>NOTE: A solid float can be checked for fuel absorption by lightly squeezing between fingers. If wetness appears on surface or float feels heavy (check with known good float), replace float assembly.</p> <p>6. After making preceding checks, adjust float assembly. Use procedure A.</p>

**Problem:** ENGINE STARTS AND STALLS

Engine does not have enough fast idle speed when cold.	Check and reset fast idle screw and fast idle cam. Use procedures B and C.
Choke vacuum break unit is not adjusted to specification or is defective.	<p>1. Adjust choke vacuum break assembly to specifications. Use procedures D and E.</p> <p>2. If adjusted O.K., check the vacuum break unit for proper operation as follows. Connect a piece of hose to the nipple on the vacuum break unit and apply suction by mouth or vacuum source. Diaphragm plunger should move inward and hold vacuum. If not, replace diaphragm unit.</p> <p>NOTE: Always check fast idle cam (choke rod) adjustment first before adjusting vacuum break unit. Use procedure C.</p>
Choke coil rod out of adjustment.	Adjust choke coil rod. Use procedure G.
Choke valve and/or linkage sticking or binding.	<p>1. Clean and align choke valve and linkage. Replace if necessary.</p> <p>2. Re-adjust if part replacement is necessary. Use procedure C, D, E and H.</p>
Idle speed setting.	Adjust idle speed to specifications on decal in engine compartment.
Not enough fuel in carburetor.	<p>1. Test fuel pump pressure and volume, as outlined in service manual.</p> <p>2. Check for partially plugged fuel inlet filter. Replace, if dirty.</p> <p>3. Check fuel tank lines and tank vent lines for being open. Clean as necessary.</p> <p>4. Remove air horn and check float adjustment. Use procedure A.</p>
<p>Carburetor flooding.</p> <p>NOTE: Check for flooding by using procedure outlined under "Engine cranks - will not start - engine flooded" Page 1.</p>	<p>1. Check all fuel filters for dirt. Clean and replace as necessary.</p> <p>2. If carburetor still floods, remove air horn and check float needle and seat for proper seal. If a needle seat tester is not available, mouth suction can be applied to the needle seat with needle installed. If needle seat leaks, replace with a factory matched set.</p>

## ROCHESTER CARBURETOR DIAGNOSIS – ALL MODELS 4M, 4MV – FOUR BARREL

**Problem:** ENGINE STARTS AND STALLS (Cont.)

POSSIBLE CAUSE	CORRECTIVE ACTION
Carburetor flooding. (continued)	3. Check float for being loaded with fuel, bent float arms or binds in float hanger.  NOTE: A solid float can be checked for fuel absorption by lightly squeezing between fingers. If wetness appears on surface or float feels heavy (check with known good float), replace float assembly.  4. Check float adjustments. <u>Use procedure A.</u>  5. If excessive dirt is found in the carburetor, clean fuel system and carburetor.

**Problem:** ENGINE IDLES ROUGH AND STALLS

Idle speed setting.	Re-set idle speed per instructions on decal in engine compartment.
Manifold vacuum hoses disconnected or improperly installed.	Check all vacuum hoses leading into the manifold or carburetor base for leaks or being disconnected. Install or replace as necessary.
Carburetor loose on intake manifold.	Torque carburetor to manifold bolts (10-14 ft. lbs.).
Intake manifold is loose or gaskets are defective.	Using a pressure oil can, spray light oil or kerosene around manifold legs and carburetor base. If engine RPM changes, tighten or replace the manifold gaskets or carburetor base gaskets as necessary.
Hot idle compensator not operating (where used).	Normally the hot idle compensator should be closed when engine is running cold and open when engine is hot (approx. 140°F at comp.) replace if defective.
Air leaks into carburetor idle channels.	Tighten all carburetor screws. If gaskets are hard or cracked, replace as necessary. <u>Use procedure I for tightening air horn screws.</u>
Poor secondary throttle valve alignment.	If mis-aligned, loosen screws, align valves, tighten screws and re-stake as necessary.
Carburetor flooding. NOTE: Check by using procedure outlined under engine flooded. Page 1.	1. Remove air horn and check float adjustments. <u>Use procedure A.</u>  2. Check float needle and seat for proper seal. If a needle seat tester is not available, mouth suction can be applied to the needle seat with needle installed. If needle and seat are defective, replace with factory matched set.  3. Check float for being loaded with fuel, bent float arm or binding float hanger.  NOTE: A solid float can be checked for fuel absorption by lightly squeezing between fingers. If wetness appears on surface or float feels heavy (check with known good float), replace float assembly.
Dirt in idle channels.	If excessive dirt is found in carburetor or idle channels, clean fuel system and carburetor. Replace fuel filters as necessary.

**Problem:** ENGINE HESITATES ON ACCELERATION.

POSSIBLE CAUSE	CORRECTIVE ACTION
Defective accelerator pump system. NOTE: A quick check of the pump system can be made as follows. With the engine off, remove air cleaner and look into carburetor bores and observe pump shooters, while briskly opening throttle valves. A full stream should emit from each pump jet and enter the center of the carburetor bore.	1. Remove carburetor air horn and check pump cup. If cracked, scored or distorted, replace pump plunger. Check pump discharge ball for proper seating and location.  To check discharge ball for proper seating, fill cavity above discharge ball with fuel. If "leak down" occurs remove discharge ball and clean check ball seat and pump passages and jets. If clean, stake discharge ball seat by tapping ball lightly against seat with drift punch and small hammer. Replace with new discharge ball.
Dirt in pump passes or pump jet.	Clean and Blow out with compressed air.
Float level	Check for sticking float needle or binding float. Free up or replace parts as necessary. Check and reset float level to specification. <u>Use procedure A.</u>
Leaking air horn to float bowl gasket.	Torque air horn to float bowl using proper tightening procedure. <u>Use procedure I.</u>
Carburetor loose on manifold.	Torque carburetor to manifold bolts (10-14 ft. lbs.).
Air valve binding (sticks open)	1. Torque air horn screws evenly using proper tightening sequence. <u>Use procedure I.</u> 2. Free-up air valve shaft and align air valves. 3. Check air valve spring for closing tension. If defective, replace with spring kit part number 7035344.
Secondary throttle valve lockout.	1. Free-up and check for proper operation. 2. Adjust secondary throttle valve lockout. <u>Use procedure H.</u>

**Problem:** NO POWER ON HEAVY ACCELERATION OR AT HIGH SPEED

Carburetor throttle valve not going wide open. (Check by pushing accelerator pedal to floor).	Adjust throttle linkage to obtain wide open throttle in carburetor.
Dirty or plugged fuel filters.	Clean or replace as necessary. Check particularly carburetor inlet filter.
Secondary throttle valves not unlocking after engine warms up.	Free-up and adjust secondary throttle lockout. <u>Use procedure H.</u>
Air valves binding, stuck closed or wide open.	1. Free-up air valve shaft and align air valves. 2. Torque air horn screws evenly using proper tightening sequence. <u>Use procedure I.</u> 3. Check air valve spring for closing tension. If defective, replace with spring kit, part number 7035344.
Power system not operating.	1. Check power piston for free up and down movement. Proceed as follows.  Use a .300 plug gauge or 19/64" drill and insert in front air horn vent stack. Push gently downward on top of power piston with engine off. Power piston should move downward approximately 1/4" and return to up position under spring tension. If power piston is sticking,

## ROCHESTER CARBURETOR DIAGNOSIS — ALL MODELS 4M, 4MV — FOUR BARREL

**Problem:** NO POWER ON HEAVY ACCELERATION  
OR AT HIGH SPEED (CONT'D)

POSSIBLE CAUSE	CORRECTIVE ACTION
Power system not operating. (continued)	remove the carburetor air horn and check power piston and cavity for dirt or scores. Check power piston spring for distortion.
Float level too low.	Check and reset float level to specification. Use procedure A.
Float not dropping far enough in bowl.	Check for bind in float hanger and float arm, float alignment in bowl and needle pull clip for sufficient clearance on float arm.
Main metering jets or metering rods dirty, plugged or incorrect part.	<ol style="list-style-type: none"> <li>1. If the main metering jets are plugged or dirty or excessive dirt is in fuel bowl, the carburetor should be completely disassembled and cleaned.</li> <li>2. If the jets or rods are incorrect size, consult the parts list for proper usage. The last two digits stamped on the primary rods and jets are the last two digits of the part number. See identification chart J.</li> </ol>

**Problem:** ENGINE STARTS HARD  
WHEN HOT

Choke valve not opening completely.	<ol style="list-style-type: none"> <li>1. Check for binding choke valve and/or linkage. Clean and/or replace as necessary. Do not oil choke linkage.</li> <li>2. Check and adjust choke thermostatic coil. Use procedure G.</li> </ol>
Engine flooded, carburetor flooding.	See procedure under "Engine cranks, will not start - engine flooded."
No fuel in carburetor.	<ol style="list-style-type: none"> <li>1. Check fuel pump. Run pressure and volume test.</li> <li>2. Check float needle for sticking in seat, or binding float.</li> <li>3. Check and adjust float level. Use procedure A.</li> </ol>
Leaking float bowl.	Fill bowl with fuel and look for leaks.

**Problem:** ENGINE RUNS UNEVEN OR SURGES.

Fuel restriction.	<p>Check all hoses and fuel lines for bends, kinks or leaks. Straighten and secure in position.</p> <p>Check all fuel filters, if plugged or dirty - replace.</p>
Dirt or water in fuel system.	Clean fuel tank, lines and filters. Remove and clean carburetor.
Fuel level.	Adjust float. Use procedure A. Check for free float and float needle valve operation. Free up or replace as necessary.
Metering rods bent or incorrect part. Main metering jets dirty, defective, loose or incorrect part.	Clean or replace as necessary. See identification chart J.
Power system in carburetor not functioning properly. Power piston sticking.	Free up or replace as necessary.
Vacuum leakage.	It is absolutely necessary that all vacuum hoses and gaskets are properly installed with no air leaks. The carburetor and manifold should be evenly tightened to specified torque. Carburetor to manifold (10-14 ft. lbs.).

**6M-60 ENGINE FUEL**

**ROCHESTER CARBURETOR DIAGNOSIS -- ALL MODELS 4M, 4MV -- FOUR BARREL**

**Problem: ENGINE RUNS UNEVEN OR SURGES (CONTINUED)**

POSSIBLE CAUSE	CORRECTIVE ACTION
Secondary throttle valves sticking open or not seating properly.	Loosen secondary throttle valve screws. Align valves in carburetor bores and tighten securely.

**Problem: POOR FUEL ECONOMY**

Engine needs complete tune up.	Check engine compression, examine spark plugs, (if dirty or improperly gapped, clean and re-gap or replace), ignition point dwell, condition, re-adjust ignition points if necessary and check and reset ignition timing. Clean or replace air cleaner element if dirty. Check for restricted exhaust system and intake manifold for leakage. Make sure all vacuum hoses are connected correctly. Also make sure T.C.S. valve and distributor vacuum advance are adjusted and operating properly.
Choke valve not fully opening.	<ol style="list-style-type: none"> <li>1. Clean choke and free-up linkage.</li> <li>2. Check choke coil for proper adjustment. Reset to specifications. Use procedure G.</li> </ol>
Fuel leaks.	Check fuel tank, fuel lines and fuel pump for any fuel leakage.
High fuel level in carburetor or carburetor flooding.	<ol style="list-style-type: none"> <li>1. Check for dirt in the needle and seat. Test using suction by mouth or needle seat tester.</li> <li>2. Check for loaded float.</li> <li>3. Re-set carburetor float to specifications. Use procedure A.</li> <li>4. If excessive dirt is present in the carburetor bowl, the carburetor should be cleaned.</li> </ol>
Power system in carburetor not functioning properly. Power piston sticking in up position.	Free up or replace as necessary.
Metering rods bent or incorrect part. Main metering jets, defective, loose or incorrect part.	Clean or replace as necessary. See identification chart J.
Fuel being pulled from accelerator system into venturi through pump jets.	Run engine at RPM where nozzles are feeding fuel. Observe pump jets. If fuel is feeding from jets, check pump discharge ball for proper seating by filling cavity above ball with fuel to level of casting. No "leak down" should occur with discharge ball in place, Re-stake or replace leaking check ball.
Air bleeds or fuel passages in carburetor dirty or plugged.	Clean carburetor or overhaul as necessary.

SERVICE PROCEDURES – ALL MODELS 4M, 4MV – FOUR BARREL

**A**

① HOLD RETAINER FIRMLY IN PLACE

② PUSH FLOAT DOWN LIGHTLY AGAINST NEEDLE

③ GAUGE FROM TOP OF CASTING TO TOP OF FLOAT AT TOE (GAUGING POINT 1/16 BACK FROM TOE) (GASKET REMOVED)

④ BEND FLOAT UP OR DOWN TO ADJUST

⑤ VISUALLY CHECK FLOAT ALIGNMENT AFTER ADJUSTING

**FLOAT LEVEL ADJUSTMENT**

**D**

② AIR VALVES MUST BE COMPLETELY CLOSED

③ PLACE GAUGE BETWEEN ROD AND END OF SLOT IN LEVER

④ BEND ROD HERE TO OBTAIN SPECIFIED CLEARANCE BETWEEN ROD AND END OF SLOT IN LEVER

① SEAT VACUUM DIAPHRAGM USING OUTSIDE VACUUM SOURCE

**AIR VALVE DASHPOT ADJUSTMENT**

**B**

① PLACE CAM FOLLOWER ON HIGH STEP OF FAST IDLE CAM

② CLOSE PRIMARY THROTTLE VALVES

③ TURN SCREW IN TO SPECIFIED FAST IDLE RPM TO ADJUST

**FAST IDLE ADJUSTMENT**

**E**

④ GAUGE BETWEEN AIR HORN WALL AND LOWER EDGE OF CHOKE VALVE

① SEAT VACUUM BREAK DIAPHRAGM USING OUTSIDE VACUUM SOURCE

② BEND VACUUM LINK TO ADJUST

③ LIGHTLY ROTATE CHOKE COIL LEVER COUNTERCLOCKWISE UNTIL END OF ROD IS IN END OF SLOT IN LEVER

⑤ OPEN PRIMARY THROTTLE VALVES SO THAT FAST IDLE CAM FOLLOWER CLEARS STEPS ON FAST IDLE CAM

**VACUUM BREAK ADJUSTMENT**

**C**

② GAUGE BETWEEN AIR HORN WALL AND LOWER EDGE OF CHOKE VALVE

③ BEND ROD TO ADJUST

① CAM FOLLOWER ON SECOND STEP OF FAST IDLE CAM AGAINST HIGHEST STEP

**FAST IDLE CAM ADJUSTMENT**

**F**

① PUSH UP LIGHTLY ON VACUUM BREAK LEVER TO CLOSE CHOKE (HOLD IN POSITION WITH RUBBER BAND)

③ GAUGE BETWEEN AIR HORN WALL AND LOWER EDGE OF CHOKE VALVE

② HOLD PRIMARY THROTTLE VALVES WIDE OPEN

④ BEND TANG ON LEVER TO ADJUST

**UNLOADER ADJUSTMENT**

**G**

② CHOKE VALVE COMPLETELY CLOSED

① ROTATE COIL LEVER COUNTERCLOCKWISE UNTIL CHOKE VALVE IS CLOSED

REMOVE THERMOSTATIC COIL ROD FROM LEVER

④ ROD SHOULD FIT IN NOTCH IN LEVER

BEND ROD TO ADJUST ⑤

HOLD DOWN ON ROD ③ AGAINST STOP

**CHOKE COIL ROD ADJUSTMENT**

**H**

① HOLD CHOKE VALVE WIDE OPEN BY ROTATING VACUUM BREAK LEVER TOWARDS OPEN CHOKE (CLOCKWISE)

② HOLD SECONDARY THROTTLE VALVES SLIGHTLY OPEN

③ MEASURE .015" CLEARANCE

④ BEND LEVER TO ADJUST SECONDARY LOCKOUT OPENING CLEARANCE

⑤ HOLD CHOKE VALVE & SECONDARY THROTTLE VALVES CLOSED

⑥ .015 MAX CLEARANCE

⑦ BEND PIN TO ADJUST SECONDARY LOCKOUT LEVER CLEARANCE

**SECONDARY LOCKOUT ADJUSTMENT**

**I**

**AIR HORN TIGHTENING SEQUENCE**

**J**

**QUADRAJET MAIN METERING JETS**

The primary main metering jets used in the Quadrajet carburetor differ from other models and should not be interchanged. They can be identified by two curved lines stamped opposite the identification number on the jet face. The identification number stamped on the jet face indicates the orifice size.

Example:

**PRIMARY JETS**

Part Number	Stamped
7031972	72
7031974	74
7031977	77

**MAIN METERING RODS—Primary**

The number indicates the diameter of the metering rod at point "A" and is the last two digits of the part number. The 1968 and later models with the double taper will have "B" stamped on the rod after the two digit number.

Example:

**PRIMARY RODS**

Part Number	Stamped
7034843	43B
7034845	45B
7034849	49B

**QUADRAJET SECONDARY METERING RODS**

The secondary rods are identified with a two letter code.

Example:

**SECONDARY RODS**

Code Letter	Part Number
CM	7045840
DA	7046010
CH	7045779



## FUEL PUMP DIAGNOSIS

### CAMSHAFT DRIVEN FUEL PUMP

Complete diagnosis of all possible causes of the trouble prior to replacement of the fuel pump will save time, expense and possibly prevent a repeat complaint.

When a fuel pump is suspected of not performing properly, the following tests must be made:

**NOTE:** Do not remove the pump for any of these inspections or tests. Be certain sufficient gasoline is in the tank.

#### INITIAL INSPECTION

1. Be certain all fittings and connections are tight and cannot leak fuel between the pump and the carburetor or air between the gas tank and the pump.
2. Look for kinks in the fuel lines.
3. With engine idling, look for leaks:
  - a. In the line between the pump and the carburetor.
  - b. At the diaphragm flange on the pump.
  - c. At the breather holes in the pump casting.
  - d. At the sheet metal cover (pump) and its fittings.
 If leaks are evident in the lines or fittings, tighten or replace as necessary. If the fuel pump leaks (diaphragm flange, sheet metal cover, or pump casting breather holes), replace the pump.

If the above steps do not cure the problem, proceed to the next test.

#### VACUUM TEST:

This will determine if the pump has the ability to pump fuel:

1. Disconnect the fuel line at the carburetor. Install a rubber hose on to the fuel line and run it back into the gas tank.
2. Disconnect the inlet fuel line at the pump. Fasten the inlet line in an up position so fuel will not run out. Install a vacuum gage on to the inlet of the pump.

3. With engine idling (using fuel in the carburetor float bowl), the vacuum should be at least 12" Hg.
4. If the vacuum is less than 12" Hg., replace pump. If the vacuum is okay, proceed to the next test.

**NOTE:** Do not be concerned if vacuum drops off after the engine is stopped. Many pumps have valves with a bleed hole that allows vapors to bleed back to the gasoline tank.

#### PRESSURE TEST:

This will determine if the pump can deliver fuel at the proper pressure to the carburetor:

1. Reconnect the inlet fuel line to the pump.
2. Reconnect the fuel line at the carburetor. Idle engine for two minutes so the carburetor float bowl can be refilled. (This step may be omitted if enough fuel remains in the carburetor after vacuum test.)
3. Disconnect fuel line at the carburetor and install a pressure gage into the end of this fuel line. If the pump has a vapor return line, pinch the line closed.
4. With the engine idling (using fuel in the carburetor float bowl), the pressure gage when held at the level of the pump outlet should read at least 3½ psi.
5. If the pressure is less than this value, determine if the line from the pump to the carburetor is restricted. If this line is restricted, replace or clean it. If the line is not restricted, remove the pump and install a new one.
6. If the pressure is okay, determine if fuel can be pulled up to the pump. Disconnect the fuel line at both the fuel pump inlet and the gas tank outlet. Blow air into the fuel pump end of the line to determine if fuel can flow through this line.

**NOTE:** Failure to disconnect the fuel line at the gasoline tank prior to blowing air, can damage the tank strainer. If the line is restricted, replace or clean it. If the line was not restricted, proceed to other areas such as gas tank or carburetor. The fuel pump is not at fault.

## SPECIAL TOOLS



J-22973



J-9789

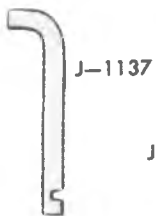

J-1137



J-4552



J-5197

### BENDING TOOLS

J-8328



J-9789 Universal Carburetor Kit  
J-22973 Ther-Mac Thermometer

J-1137 Choke Rod Bending  
J-4552 Choke Rod Bending (1 2 bbl.)  
J-5197 Unloader Bending  
J-8328 Carburetor Holding Tool

Fig. 5P--Engine Fuel · Special Tools

# SECTION 6T

## EMISSION CONTROL SYSTEMS

### CONTENTS OF THIS SECTION

Positive Crankcase Ventilation..... 6T-1 Controlled Combustion System..... 6T-3 Evaporation Emission Control..... 6T-6	Exhaust Gas Recirculation System..... 6T-7 Transmission Controlled Spark System..... 6T-10 Air Injection Reactor System..... 6T-21
--	--

## POSITIVE CRANKCASE VENTILATION

### THEORY OF OPERATION

During the combustion process in a gasoline engine, a highly corrosive gas is produced. Also, for every gallon of gasoline burned, more than a gallon of water is formed. During the last part of the combustion stroke, some of the unburned fuel and products of combustion leak past the piston rings into the crankcase. This leakage is a result of four factors (Fig. 1a):

1. High combustion chamber pressures.
2. Necessary working clearance of piston rings in their grooves.
3. Normal ring shifting that sometimes lines up clearance gaps of two or more rings.
4. Reduction in ring sealing contact area with change in direction of piston travel.

This blow-by must be removed before it condenses in the crankcase and reacts with the oil to form sludge which, if circulated with the oil, will cause corrosive and accelerated wear of pistons, rings, valves, bearings, etc. Because this blow-by also carries with it a certain quantity of unburned fuel, oil dilution will take place if it is not removed.



Fig. 1a—Engine Blow-By

These harmful gases are removed from the crankcase through a system utilizing engine vacuum to draw fresh air through the crankcase (Fig. 2a).

Fresh air enters the Positive Crankcase Ventilation (PCV) system from the clean air side of the air cleaner or through a separate breather filter on the periphery of the air cleaner.

Since the vacuum supply for the PCV system is from the intake manifold, the flow through this system into the manifold must be controlled in such a manner that it varies in proportion to the regular air-fuel ratio being drawn into the intake manifold through the carburetor. The flow through the PCV system into the intake manifold is regulated by a PCV valve on all engines (Fig. 3a).

The PCV valve varies the amount of flow through the system according to the various modes of operation (i.e. idle, cruise, acceleration etc.). The valve itself consists of a coil spring, valve, and a two-piece outer body which is crimped together. The valve dimensions, spring, and

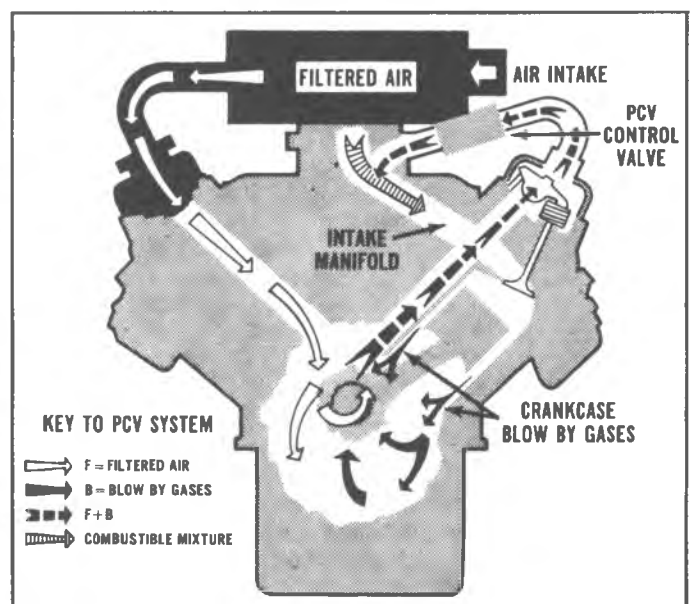

Fig. 2a—Schematic of PCV System

## 6T-2 EMISSION CONTROL SYSTEMS

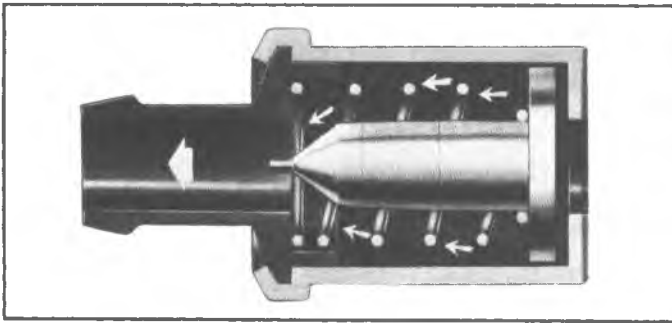

Fig. 3a—PCV Valve Cross Section

internal dimensions are such to produce the desired air flow requirements.

During periods of deceleration and idle, manifold vacuum is high. The high vacuum overcomes the force of the valve spring, and the valve bottoms in the manifold end of the valve housing. This does not completely stop the flow but it does restrict the flow of crankcase vapors to the intake manifold (Fig. 4a).

When the engine is accelerated or operated at constant speed, intake manifold vacuum is less than at idle or during deceleration. The spring force is stronger than the vacuum pull during this mode so the valve is forced toward the crankcase end of the valve housing. With the valve in this position, more crankcase vapors flow into the intake manifold (Fig. 5a).

In the event of a backfire, the valve plunger is forced back and seated against the inlet of the valve body. This prevents the backfire from traveling through the valve and connecting hose into the crankcase (Fig. 6a). If the backfire was allowed to enter the crankcase, it would ignite the volatile crankcase blow-by gases and result in an explosion.

It should be noted that additional air is permitted to enter the intake manifold when positive crankcase ventilation is used. However, the carburetor used with this system is calibrated to compensate for the air plus blow-by gas that enters the intake manifold from the crankcase.

As can be seen from the foregoing discussion, the Positive Crankcase Ventilation system provides for proper air flow through it during all operating conditions. In addition, the crankcase vapors are returned rather than exhausted to the atmosphere - thus helping reduce our air pollution problem.

So far, we have discussed the two major benefits of the PCV system - namely, venting of detrimental crankcase vapors and air pollution reduction. There is a third benefit of this system that is equally as important to an owner; that is - Better Gas Economy. The recirculated vapor returned to the intake manifold is a combustible mixture. It, in effect, becomes fuel for operation when mixed with the air fuel ratio from the carburetor.

In summary then, the PCV system provides:

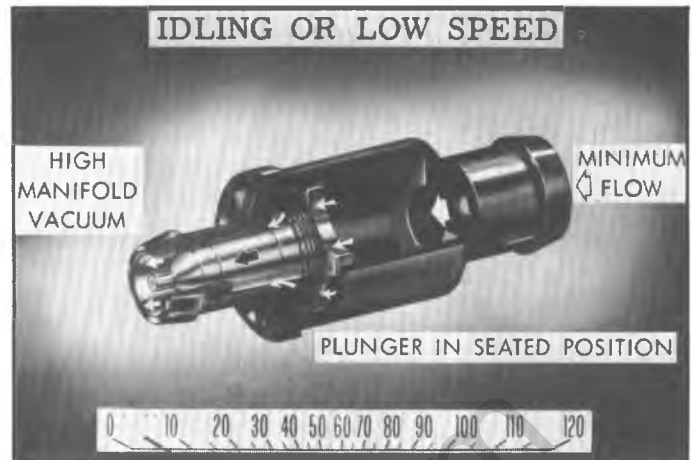

Fig. 4a—PCV Valve Position - Idle or Low Speed



Fig. 5a—PCV Valve Position - High Speed or Cruise Operation

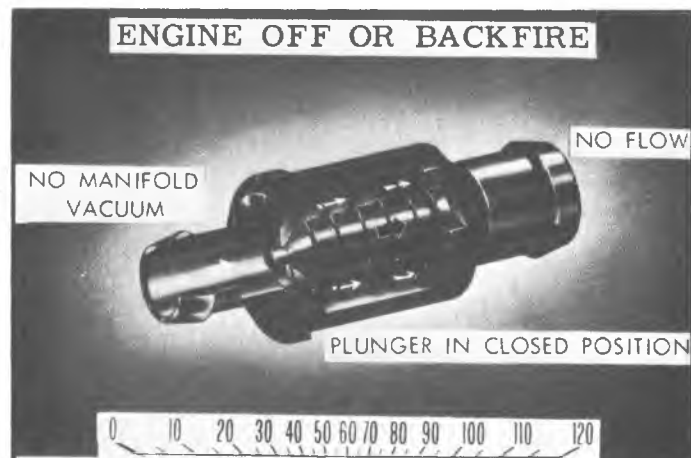

Fig. 6a—PCV Valve Position - Engine "OFF" or "Backfire" Condition

- Longer Engine Life - Draws harmful blow-by gases out of the crankcase.
- Reduction of Air Pollution - Returns crankcase

vapors rather than exhausting them into the atmosphere.

- Increases Gasoline Economy - Reclaims unburned

blow-by gases by returning them to the intake manifold.

## DIAGNOSIS

The PCV system should be checked for satisfactory operation at 12-month or 12,000 mile intervals, using a tester such as the AC CT-3 tester or equivalent.

Replace the PCV valve at 24 months or 24,000 mile intervals (whichever occurs first). The PCV valve hose, when removed for valve replacement, should be blown out with an air hose to make certain that it not restricted. The PCV valve should be replaced at 12 months or 12,000 miles (whichever occurs first) when the vehicle is used under the following conditions:

- Driving in dusty conditions.
- Extensive idling.
- Short trip operation at freezing temperatures (engine not thoroughly warmed up).

The crankcase breather filter located in the air cleaner should be replaced at 24 months or 24,000 mile intervals in normal vehicle service. When driving in dusty conditions, a 12 month or 12,000 mile service interval is recommended.

Engine operating conditions indicative of improper Positive Crankcase Ventilation System operation usually are accompanied by one or more of the following conditions:

1. Rough Idle
2. Oil Present in Air Cleaner
3. Oil Leaks
4. Excessive Oil Sludging or Diluting

If any of the above conditions are observed, corrective action; such as: PCV valve replacement, hose replacement flame arrestor cleaning or replacement or PCV breather (located in the air cleaner) replacement, should be accomplished as required to eliminate the malfunction.

Proper operation of the PCV system is dependent upon a sealed engine. If oil sludging or dilution is noted, and the PCV system is functioning properly, check engine for possible cause and correct to ensure that system will function as intended.

## CONTROLLED COMBUSTION SYSTEM

### THEORY OF OPERATION

In essence the Controlled Combustion System (CCS) increases combustion efficiency through carburetor and distributor calibrations and by increasing engine operating temperature (Fig. 1b).

Although the CCS system imposes no additional components, other than a special air cleaner assembly that is used in conjunction with it, an understanding of how exhaust emissions are reduced would be beneficial.

In general it can be said that CCS carburetors are calibrated leaner and timing is retarded during low speed or deceleration operations as compared to systems used in prior years. However, this does not always hold true. The system was individually developed on each engine-transmission combination. Various adjustments were made to reduce the hydrocarbon and carbon monoxide emissions. The exact provision or adjustment made was not the same for each engine-transmission combination.

The following provisions have been made on all CCS systems. Exceptions to these provisions will be noted.

#### Carburetors

Most carburetors used with CCS system are the same as

carburetors used in prior years but specially calibrated throughout their driving ranges for optimum emission control as well as the usual parameters of vehicle performance, economy and driving feel.

All CCS carburetors have an internal provision that allows production to refine part throttle calibration to meet very accurate air/fuel ratios and thus reduce emissions in this sensitive area.

**NOTE:** All carburetors are equipped with idle mixture limiter caps; no attempt should be made to adjust mixture - do not remove mixture screw caps.

#### Distributors and Timing

As mentioned initial ignition timing is slightly retarded over previous years. If you took two equal engines of which one had its timing retarded with respect to the other, a wider throttle plate opening would be required to obtain the same RPM on the engine with retarded spark. With a wider throttle plate opening, more air can be drawn into the intake manifold and thus less fuel enrichment during idle or deceleration conditions (Fig. 2b).

## 6T-4 EMISSION CONTROL SYSTEMS

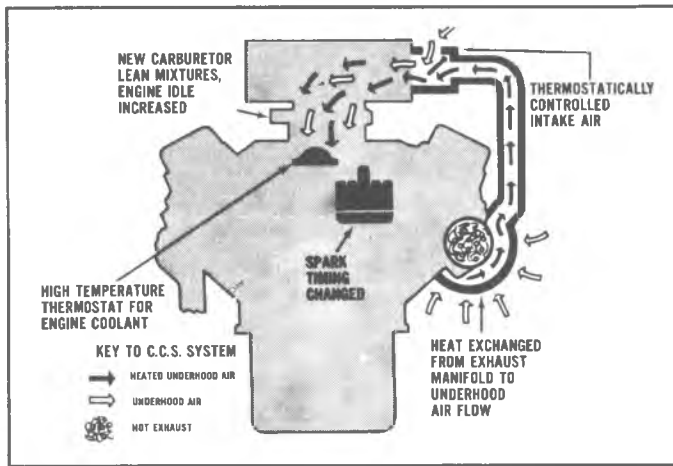

Fig. 1b—Schematic of Controlled Combustion System

Vacuum for the spark advance is taken from a point above the carburetor's throttle plate (throttle in closed position). At engine idle, this port is above the throttle blade and no vacuum is available. Without vacuum, the timing is retarded. As the throttle is opened, the port is uncovered providing vacuum spark advance for normal operation (Fig. 3b).

### Cooling System

With the introduction CCS, higher engine coolant temperatures were necessary; therefore, a 195°F coolant thermostat was employed - previous thermostats were rated at 180°F. Hotter running engines help reduce hydrocarbon emissions by providing more complete vaporization and also by reducing quench area. Quench area is the area of each cylinder that is near the cylinder wall. The cylinder walls are relatively cold in comparison to the center of the cylinder bore. As the air fuel mixture enters the chamber in its vaporous state, the mixture that expands against the relatively cool cylinder walls condenses to a certain extent. As the ignition flame travels from the spark plug, it fails to ignite these condensed vapors near the cylinder walls. By increasing the coolant temperature the size of the quench area is reduced and thus the ignition flame can consume more of the fuel thus reducing emission content (Fig. 4b).

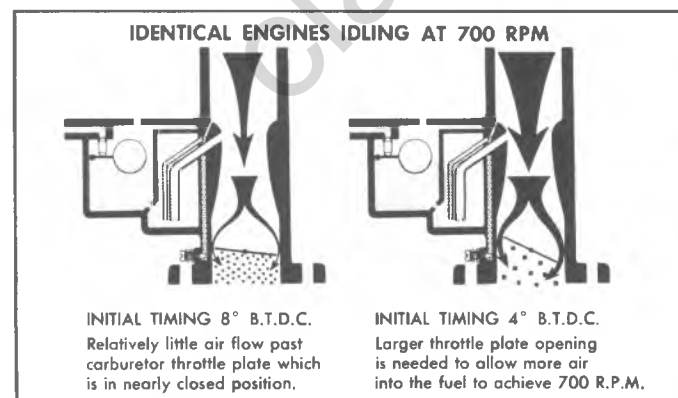

Fig. 2b—Relation of Timing to Exhaust Emission

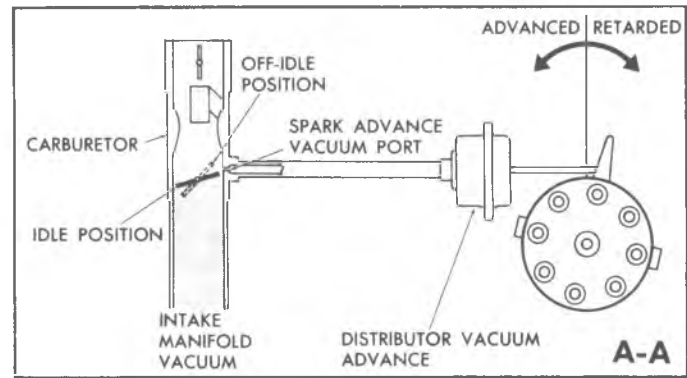

Fig. 3b—Schematic of "Ported" Spark Advance

### Thermostatically Controlled Air Cleaners

All CCS systems incorporate a "thermostatically controlled air cleaner". The thermostatic air cleaner system (referred to as ThermAC System) is designed to keep air entering the carburetor at approximately 100°F. when underhood temperatures are less than 100°F. By keeping the air at 100°F. or more, the carburetor can be "leanly" calibrated to reduce hydrocarbon emission, minimize carburetor icing, and improve engine warm-up characteristics.

The thermostatically controlled air cleaner system is composed of a special air cleaner and a heat stove. The heat stove is nothing more than a sheet metal case surrounding the exhaust manifold that traps the heat generated from the manifold and uses it to heat the air going to the carburetor. The air cleaner primarily consists of a body, filter element, sensor unit, vacuum diaphragm assembly, damper door, and connecting vacuum hoses and links (Fig. 5b).

The body and filter element resemble a conventional snorkel type air cleaner. The sensor unit is mounted in

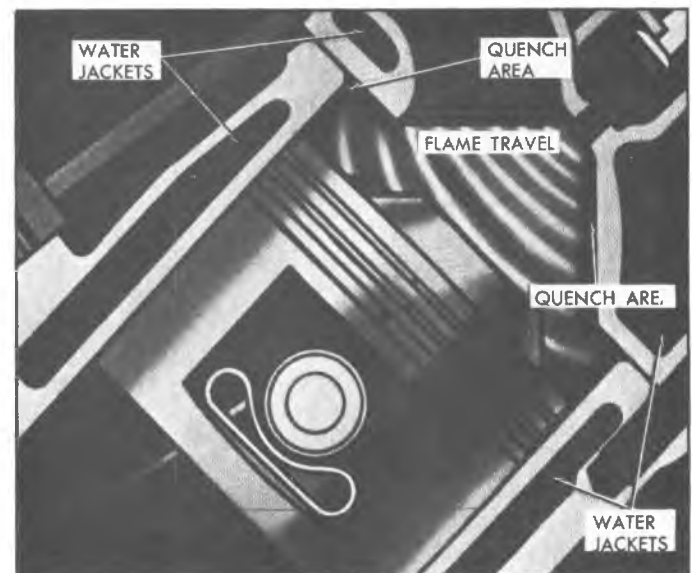

Fig. 4b—Cylinder Quench Area

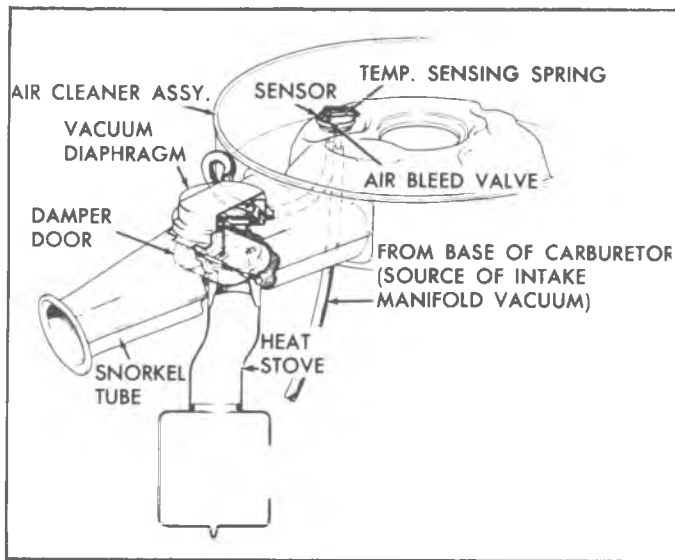

Fig. 5b—Thermostatically Controlled Air Cleaner

the body on the clean air side of the filter. The sensor unit regulates (depending upon the temperature of the air passing by it) the amount of vacuum supplied to the vacuum diaphragm. The vacuum diaphragm (depending on the amount of vacuum supplied to it by the sensing unit) opens the damper door allowing heated air from the heat stove to enter the cleaner and shuts off the passage for ambient air. The damper door is fully open (all warm air) at 8 inches of mercury and fully closed (ambient air only) at 6 inches of mercury or less. The vacuum signal measured at the diaphragm assembly will not be the same as actual engine vacuum as the thermostatic control valve in the sensor unit provides a controlled vacuum leak for regulation of the supply signal. A bi-metal strip in combination with a needle

valve type operation accomplishes the temperature sensitive controlled vacuum leak.

The thermostatically controlled air cleaner functions as follows (Fig. 6b):

When the engine is "off" (View A), no vacuum is present at the sensor unit nor at the vacuum diaphragm. The force of the vacuum diaphragm spring closes off the "heated air" passage (snorkel passage open).

When the engine is initially started (View B), the sensor unit's bimetal strip senses cool air temperature (below 85°F). The thermostat control valve of the sensor unit closes its air bleed passage allowing maximum vacuum to the vacuum diaphragm. Maximum vacuum at the vacuum diaphragm completely opens the damper door, closing off the ambient air passage through the snorkel and opening the air passage feed by the air heat stove. Should the engine be heavily accelerated while in this mode, the vacuum level in the system will drop to a low enough level so that the diaphragm spring will overcome the vacuum and push the damper door closed permitting ambient air passage through the snorkel.

As the engine heats up and air passage past the sensor reaches approximately 128°F (View C), the sensor's thermostatic control valve bleed passage is completely opened by the bimetal spring acting upon the needle. Air bleeding into the vacuum acting on the diaphragm assembly lowers the vacuum level enough so that the diaphragm spring closes the damper door, thus opening the cold air passage (ambient air through snorkel) and closing the hot air passage (heat stove passage).

At temperatures between 85° and 128°F (View D), varying amounts of air is bled into the system, depending on the exact temperature at the sensor unit. This results in a vacuum level and damper position required to maintain carburetor air temperature at from 85° to 128°F when underhood temperatures are below this range.

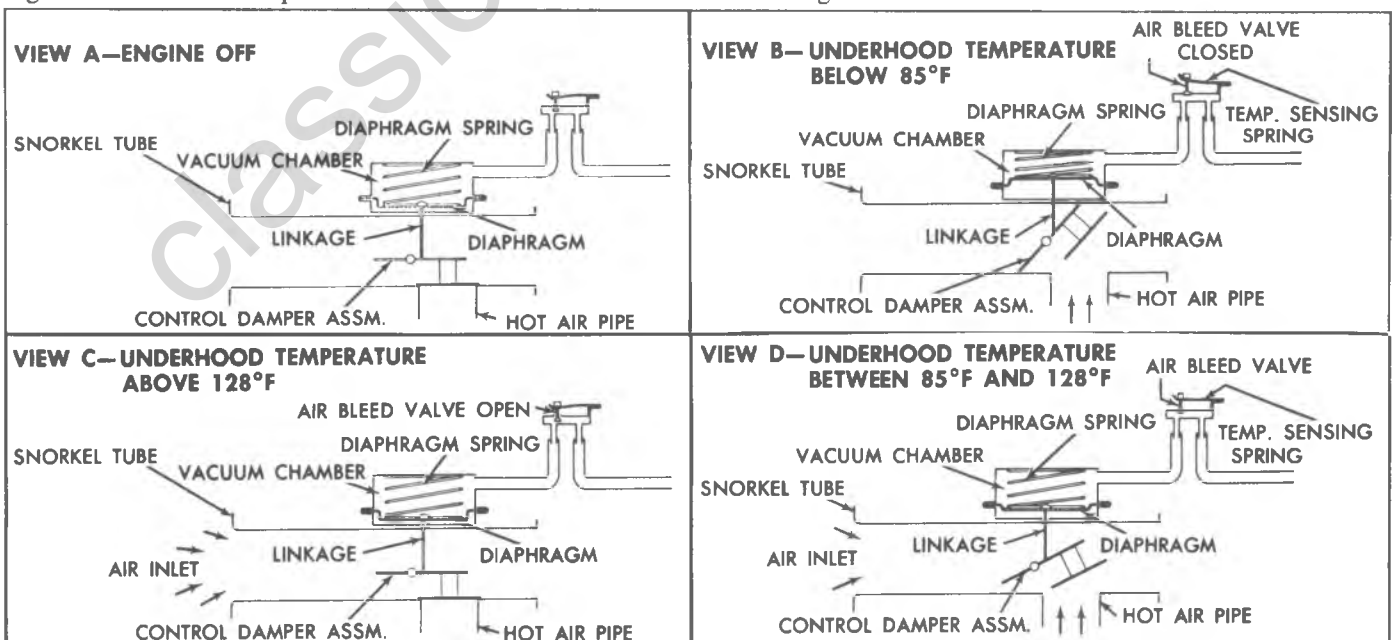

Fig. 6b—Thermostatically Controlled Air Cleaner Operation

## DIAGNOSIS

Proper system function relies upon component performance as outlined under system operation and description. Only the air cleaner is discussed in the following checks, refer to applicable section for other system components.

### Operation Check

1. Remove air cleaner cover and install temperature gauge (Tool J-22973) as close as possible to sensor (Fig. 7b). Reinstall cover without wing nut. If vehicle has been in recent operation and temperature at sensor unit is above 85°F, remove air cleaner assembly and let it cool to below 85°F. Reinstall air cleaner assembly and cover. Do not install wing nut.
2. Observe damper door position through snorkel opening. If position of snorkel makes observation difficult use the aid of a mirror. At this point the damper door should be in such a position that the heat stove passage is covered (snorkel passage open). If not, check for binds in linkage.
3. Start and idle engine. Observe damper door position through snorkel. It should initially be in a position that closes off the snorkel passage if ambient temperatures are below 85°F. When damper door begins to open remove air cleaner cover and observe thermometer reading. It should be between 85°F and 115°F.

4. If damper door opens before 85°F, replace sensor unit (do not try to adjust).
5. If damper door does not open at correct temperature continue with the following vacuum diaphragm check:
  - a. Turn off engine. Disconnect diaphragm assembly vacuum hose at sensor unit. Damper door should completely close heat stove passage at this point. If not, check linkage for a binding condition.
  - b. Apply at least 9 In. Hg. of vacuum to diaphragm assembly through hose disconnected at sensor unit. This can be done by mouth. Damper door should completely close snorkel passage when vacuum is applied. If not check to see if linkage is hooked up correctly and for a vacuum leak.
  - c. With vacuum applied, bend or clamp hose to trap vacuum in diaphragm assembly (Fig. 8b). Damper door should remain in position (closed snorkel passage). If it does not, there is a vacuum leak in diaphragm assembly. Replace diaphragm assembly.
6. If vacuum diaphragm check is found satisfactory, replace sensor unit. Do not try to adjust.

## EVAPORATION EMISSION CONTROL

This system is designed to reduce fuel vapor emission that normally vents to the atmosphere from the gasoline tank and carburetor fuel bowl. The air cleaner filter mounted at the bottom of the canister requires

replacement at intervals specified in Section 0. All other parts are serviced as a complete replacement as outlined in Section 8.

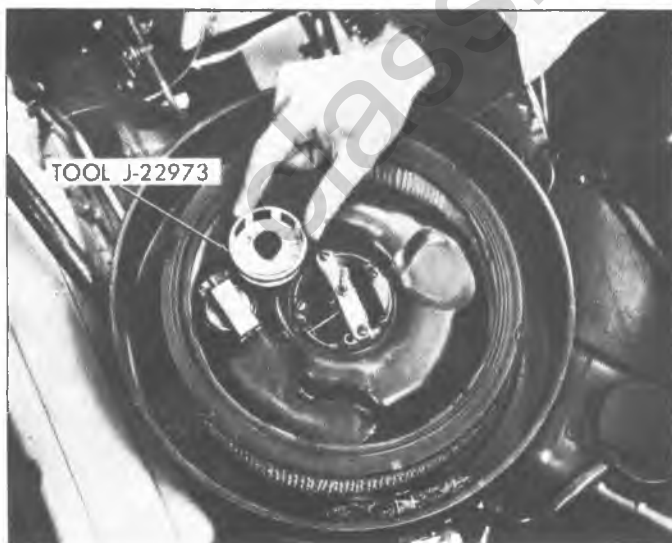

Fig. 7b—Checking Sensor Unit



Fig. 8b—Checking Vacuum Diaphragm



## EXHAUST GAS RECIRCULATION SYSTEM DESCRIPTION AND OPERATION

The Exhaust Gas Recirculation (EGR) system is used to reduce oxides of nitrogen (NO<sub>x</sub>) emitted from the engine exhaust. Formation of NO<sub>x</sub> takes place at very high temperatures, consequently, it occurs during the peak temperature period of the combustion process. To reduce and control NO<sub>x</sub> formation only a slight reduction in peak temperatures is required. This reduction can be accomplished by introducing small amounts of an inert gas into the combustion process. The end products of combustion provide a continuous supply of relatively inert gases, therefore, it becomes a matter of utilizing those gases in the correct proportion.

To tap this continuous supply of inert gases, without external pipes or connection to the exhaust system, additional exhaust gas passages are cast into the complex runner system of the inlet manifold. Separating the two EGR passages is a vacuum modulated shut-off and metering valve, referred to as the "EGR valve" (fig. 1c and 2c). The EGR valve contains a vacuum diaphragm, which is operated by intake manifold vacuum. The diaphragm vacuum signal supply port is located in the carburetor throttle body, and is exposed to engine manifold vacuum in the off-idle and part throttle to wide open throttle operation. A .030 orifice in the valve vacuum tube serves to modulate flow.

A thermal vacuum switch, mounted in the thermostat (water outlet) housing shuts off vacuum to the EGR valve until water temperature is approximately 100°.

The dual diaphragm EGR valve (fig. 1c) is designed to provide increased exhaust gas recirculation rates with increased engine loads. Manifold vacuum is used as the signal to indicate the engine load.

The valve is similar to the single diaphragm valve except

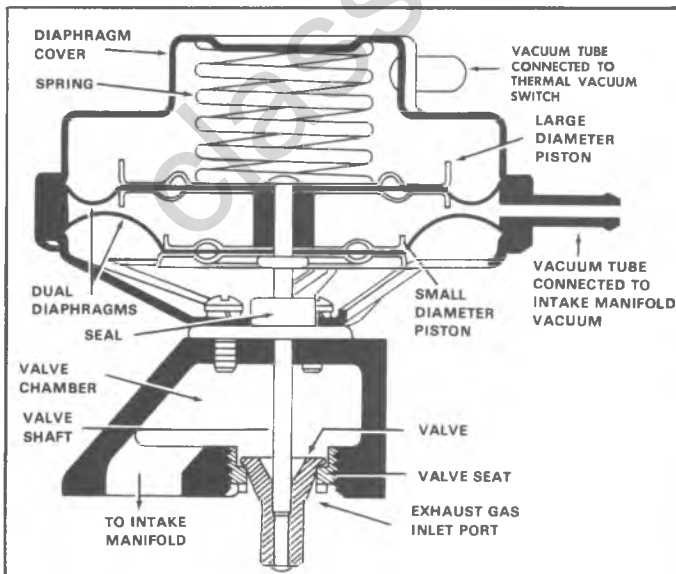

Fig. 1c—Dual Diaphragm EGR Valve

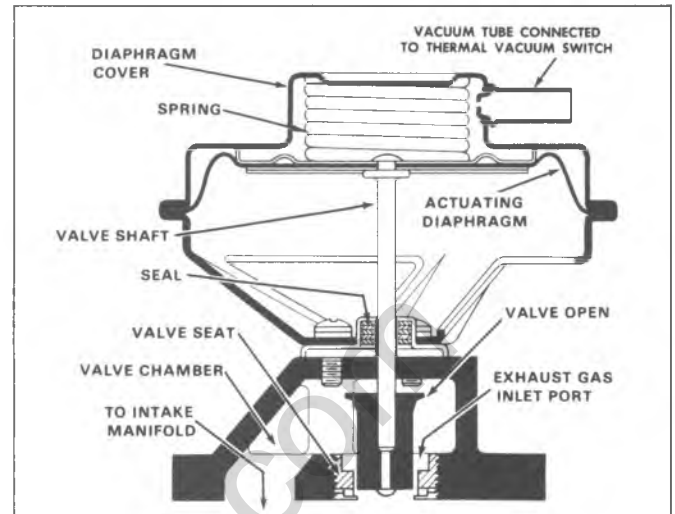

Fig. 2c—Single Diaphragm EGR Valve

that a second diaphragm has been added to the valve which is connected to the upper diaphragm, with a spacer and so the diaphragms move together. A manifold vacuum signal is applied to the volume between the two diaphragms. The upper diaphragm has a larger effective area than the lower diaphragm so that the load caused by the manifold vacuum between the two diaphragms is additive to the spring load. Thus as the engine load is increased and manifold vacuum decreases the combined load of the spring and the vacuum chamber are reduced allowing the valve to open further for a given EGR vacuum signal.

Therefore, for high intake manifold vacuums as would

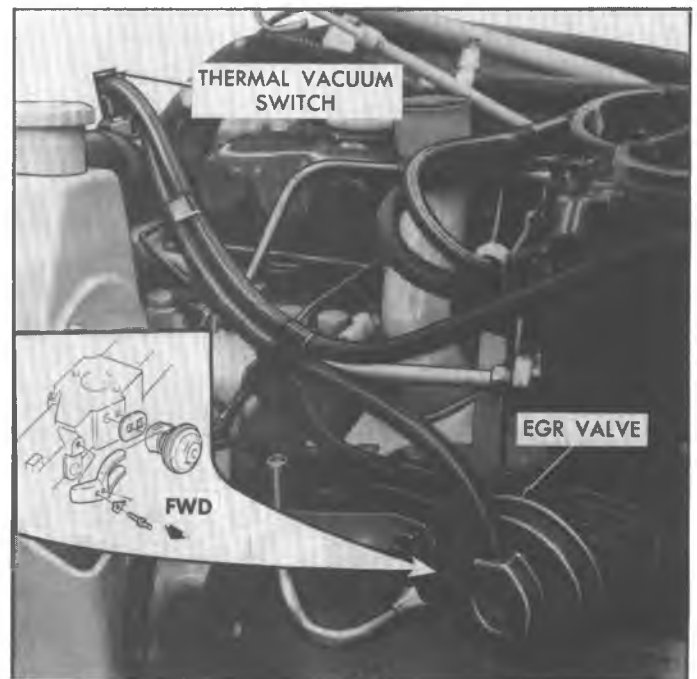

Fig. 3c—EGR Valve and Manifold (L-6)

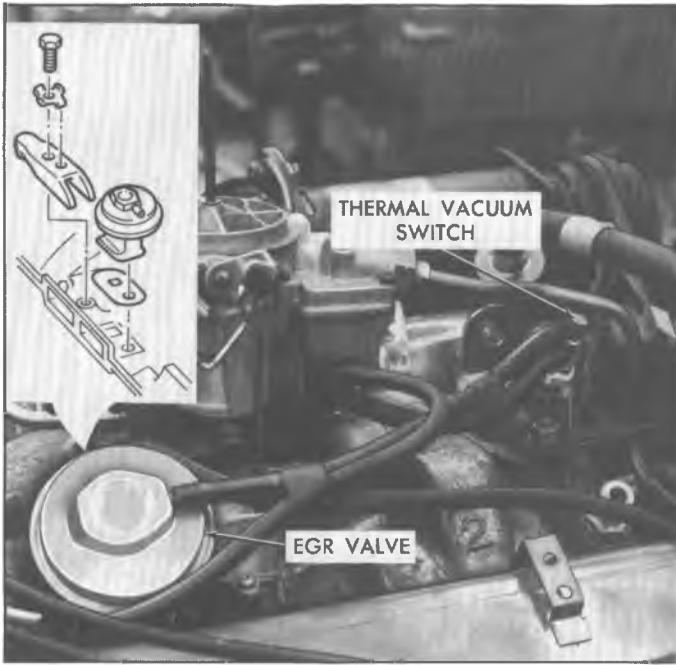

Fig. 4c—EGR Valve and Manifold (Small V8)

be experienced in cruising, the opening is less than for low manifold vacuums obtained during accelerations. The valve now is capable of providing more recirculation on accelerations where loads are higher and the tendency to produce NOx is greater.

On In-Line engines the EGR valve is located on the inlet manifold adjacent to the carburetor. Exhaust gases are diverted from the manifold heat box through the EGR valve and into the inlet manifold through a drilled hole (fig. 3c).

Small V8 engines have the EGR valve located externally on the right rear side of the inlet manifold adjacent to the rocker arm cover. Internally cast passages direct the exhaust gases to the area just below the carburetor throttle plates (fig. 4c).

The EGR valve is positioned in the left front corner of the inlet manifold in front of the carburetor on all Mark IV engines. The internally cast passages permit exhaust gases to flow to the combustion area through the inlet manifold (fig. 5c).

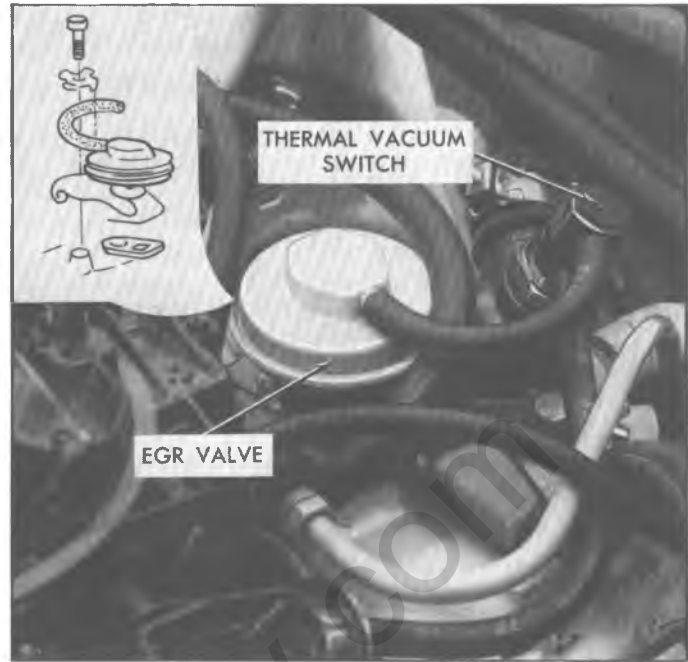

Fig. 5c—EGR Valve and Manifold (Mark IV V8)

Not all engine operational modes are critical as far as NOx emissions are concerned, the EGR valve and vacuum source is designed to vary the amount of exhaust gases recirculated. At idle, no recirculation is needed, consequently, the opening, or vacuum source, for the tube that connects the EGR valve is placed just above the throttle blade.

Therefore, at idle (throttle blade closed) the EGR valve is closed. When the throttle is opened to accelerate, the EGR valve begins opening at approximately three inches of mercury pressure drop in the throttle body.

Valve metering is constant above five inches of mercury pressure differential. The valve is quickly brought to full open when accelerating from the throttle closed condition. Approaching full throttle, when manifold vacuum is below approximately three inches of mercury the EGR valve closes. Only a very small portion of the exhaust gases is used with maximum flow occurring during the 30 to 70 miles per hour cruise condition.

## SERVICE OPERATIONS

### EGR Valve Replacement

1. Disconnect EGR valve vacuum line(s) at valve.
2. Remove clamp bolt securing valve to manifold.
3. Remove EGR valve and clamp from manifold.
4. Reassemble valve to manifold, using a new gasket.
5. Torque clamp bolt to 15-20 lb. ft., and bend lock tab over bolt head.
6. Connect carburetor vacuum signal line to tube at

top of valve.

7. Connect manifold vacuum signal line to tube at center of valve (dual diaphragm valve only).

### EGR Valve Inspection

1. Remove valve from engine and manually depress the EGR valve diaphragm to make sure valve is free - if diaphragm cannot be moved manually valve should be cleaned before proceeding with check.

- Apply approximately 9 inches of vacuum to the vacuum tube on top of EGR valve. The valve should move to the fully open position, and should remain open - no leak down - with vacuum applied. On dual diaphragm valves, apply approximately 9 inches of vacuum to vacuum tube at center of valve and check for leakdown (valve will not open in this check).
- If a leak is noted, repair or replace as required.

**CAUTION:** Replace only with identical part number.

- Inspect the valve seat and pintle for deposits. If deposits exist, clean the valve.

### EGR Valve Check

A rough idling engine may be caused by a malfunction of the EGR valve; such as, exhaust deposits holding the valve open, broken diaphragm spring, vacuum hose disconnected, a ruptured diaphragm or a leaky gasket.

If inspection procedure does not indicate any of the above malfunctions, then install a new valve or cover the valve pad on the manifold with a plate and a new gasket. Plug and disconnect vacuum lines. If proper idle performance is restored, proceed with cleaning old valve. If cleaned valve does not restore proper idle, then valve must be replaced.

### EGR Valve Cleaning

**CAUTION:** Do not wash valve assembly in solvents or degreaser - permanent damage to valve diaphragm may result.

- Clean base of valve with a wire brush or wheel to remove old gasket from mounting surface.
- Valve seat and pintle should be cleaned in a standard abrasive-type spark plug cleaning machine.
- Insert valve and pintle into opening in cleaning machine, and blast for approximately 30 seconds.
- Compress diaphragm spring so that valve is fully unseated, repeat cleaning for approximately 30 seconds.
- Inspect valve to ensure that exhaust deposits have been removed - repeat cleaning procedure as required to remove all deposits.
- Air blast valve seat and pintle area to ensure that abrasive material is thoroughly removed from valve.

### EGR Passages

If inspection of EGR passages in the inlet manifold indicate excessive build up of deposits, the passages should be cleaned. Care should be taken to ensure that all loose particles are completely removed to prevent them from clogging the EGR valve or from being ingested into the engine.

## Thermal Vacuum Switch Functional Check

### HOT CHECK

**NOTE:** This is to be performed as part of the emission maintenance routine at 12,000 miles or 12 months.

The EGR Thermal Vacuum Delay Switch should be open above 100°F coolant temperature, permitting the ported vacuum signal to reach the EGR valve above that temperature. Check as follows:

- Remove EGR valve vacuum hose at EGR valve and connect hose to a vacuum gage.
- Start engine. With transmission selector lever in Neutral or Park open throttle partially. (Do not overspeed engine.) As throttle is opened, the vacuum gage should respond with an increase in vacuum reading. (Note: Coolant temperature must be above 105°F during this test. Allow about 3 minutes at idle to warm up a cold engine. If coolant is below 75°F greater time may be required.)
- If operation is satisfactory, remove gage and reconnect hose to EGR valve. If gage does not respond to throttle opening, proceed to Step 4.
- Remove Carb-to-switch hose from switch and connect hose to vacuum gage. Repeat Step 2.
- If vacuum gage responds to throttle opening, then switch is defective. Remove switch and replace with new part. If gage does not respond to throttle opening, then check for plugged hose or defective carburetor.

### COLD CHECK

**NOTE:** This check may be performed in diagnosing complaint of stall after cold start or poor driveability immediately after cold start.

The EGR thermal vacuum delay switch should be closed below 100°F coolant temperature, thereby blocking the ported vacuum signal from reaching the EGR valve below that temperature. Check as follows:

- Drain coolant below level of thermostat housing.
- Disconnect vacuum lines and remove switch from thermostat housing.
- Inspect switch to make sure it is in good condition.
- Connect a vacuum hose to lower nipple of switch, marked "C" or "CARB". Connect a vacuum gage to upper nipple, marked "E" or "EGR".
- Place switch in water at 85°F and submerge completely for 2 minutes while agitating water thoroughly.
- Apply 12 inches Hg vacuum to hose on lower nipple of switch. Under this condition, the switch should be closed.

**Note:** Leakage of up to 2 inches of vacuum in 2 minutes is allowable and does not constitute a defective switch.

- If operation is satisfactory, re-install switch in thermostat housing. If switch is defective, replace with new part.

# TRANSMISSION CONTROLLED SPARK SYSTEM

## SIX-CYLINDER ENGINE

The Transmission Controlled Spark System is used on all 10 Series vehicles, C-K20 Suburban, G20 Series and G30 Sportvans, equipped with manual transmission.

### DESCRIPTION

Control of exhaust emitted by vehicles using the six-cylinder engine, is accomplished by preventing ignition vacuum advance when the vehicle is operating in reverse, neutral or low forward gears.

Vacuum advance is controlled by a solenoid-operated valve, which is energized by grounding a normally open switch at the transmission. When the solenoid is in the non-energized position, vacuum to the distributor advance unit is shut off and the distributor is vented to atmosphere through a filter at the opposite end of the solenoid – venting the distributor advance unit prevents it from becoming locked at an advanced position. When the solenoid is energized, the vacuum port is uncovered and the plunger is seated at the opposite end, shutting off the clean air vent.

The vacuum advance solenoid is controlled by two switches and a time relay. The solenoid is energized in the high forward gear and in reverse on Hydra-matic by a transmission operated switch. A thermostatic coolant temperature switch is used to provide thermal override below 93°F. The time relay is incorporated in the circuit to energize the vacuum advance solenoid for approximately 20 seconds after the ignition key is turned on. The relay's 20 second delay begins when the ignition key is turned on, but the solenoid will remain energized as long as coolant temperature is below 93°F.

Wider throttle blade openings at idle are required to compensate for the retarded spark condition produced by the design of the emission reduction system. To prevent engine dieseling at engine shut down, an idle stop solenoid is provided. The ignition activated idle stop

solenoid eliminates dieseling tendencies by allowing the throttle valve to close beyond the normal idle position when the ignition is turned off.

### SYSTEM THEORY

The TCS system components are shown in their normal at rest position with the engine off and cold (fig. 1d). The temperature switch points are closed, making contact with the cold terminal; the time relay points are closed, transmission switch points are open; vacuum advance solenoid is de-energized, plunger retracted and blocking distributor vacuum advance and opening the distributor vacuum advance unit to atmosphere; idle stop solenoid is de-energized with plunger retracted.

When the ignition switch is turned on the idle stop solenoid is energized, extending the plunger to contact the throttle lever. A circuit is completed from the

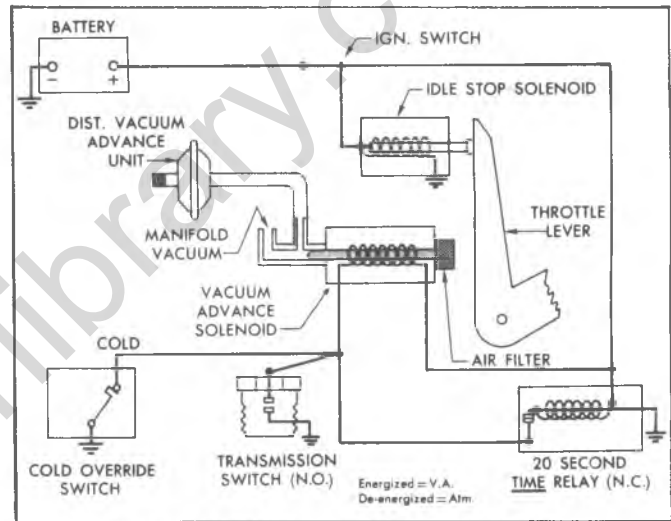

Fig. 2d—L-6 TCS System (Cold Override & Time Relay Energized)

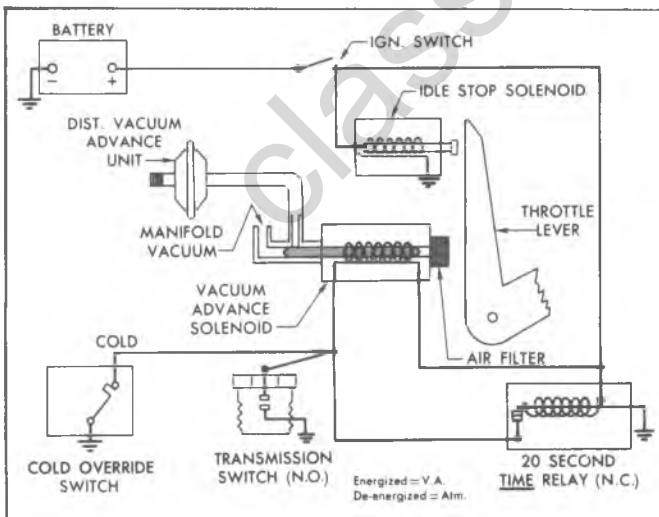

Fig. 1d—L-6 TCS System (Engine Off)

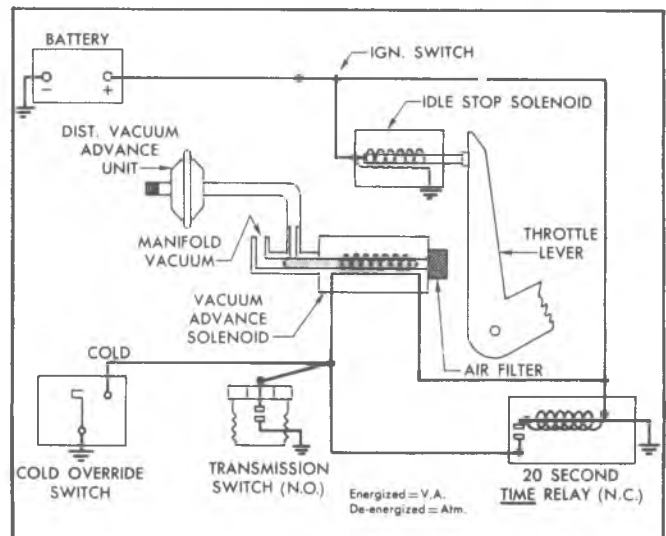

Fig. 3d—L-6 TCS System (Low Gear Operation)

ignition switch through the vacuum advance solenoid and through the temperature switch cold terminal to ground. At the same time another circuit is energized — this is from the ignition switch through the time relay coil and to ground, also as long as the relay points are closed it provides a path to ground for the vacuum advance solenoid (fig. 2d). With either one or both of the above circuits complete, the vacuum advance solenoid is energized; permitting vacuum advance to distributor.

In low gear operation, with engine temperature above 93 degrees, the temperature switch cold override points open (fig. 3d). If 20 seconds have elapsed the time relay points are open also. This breaks the circuit(s) de-energizing the vacuum advance solenoid, allowing the plunger to block vacuum and open advance unit to atmosphere.

When the transmission is shifted into high forward gear, the transmission switch points are closed by shift action (fig. 4d).

This completes the circuit from the ignition switch through the vacuum advance solenoid and through the closed transmission switch points to ground. The vacuum advance solenoid is energized.

## COMPONENT DESCRIPTION

### Idle Stop Solenoid

The idle stop solenoid is a two position electrically operated control, used to provide a predetermined throttle setting (fig. 5d). In the energized position (plunger extended) the plunger contacts the carburetor throttle lever and prevents full closing of the carburetor throttle plates. This fast idle control when de-energized (plunger retracted) allows throttle plates to close beyond the normal idle position; thereby shutting off air supply and in essence starving the engine so that it will shut down without dieseling. The idle stop solenoid is bracket-attached to the carburetor so that the plunger, when extended, contacts the throttle lever.

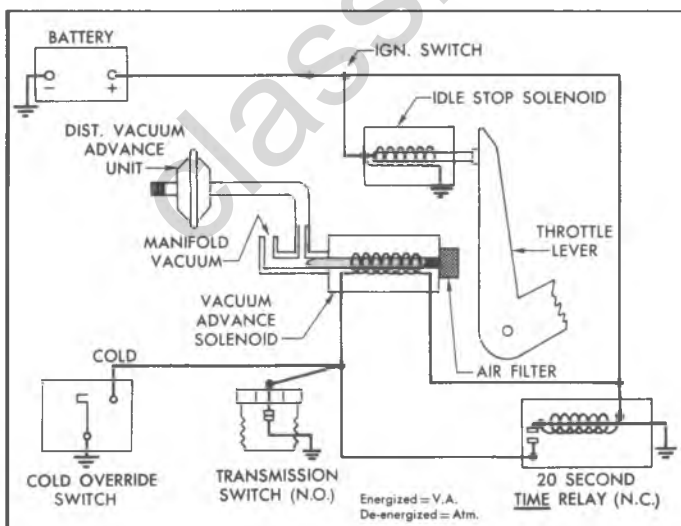

Fig. 4d—L-6 TCS System (High Gear Operation)

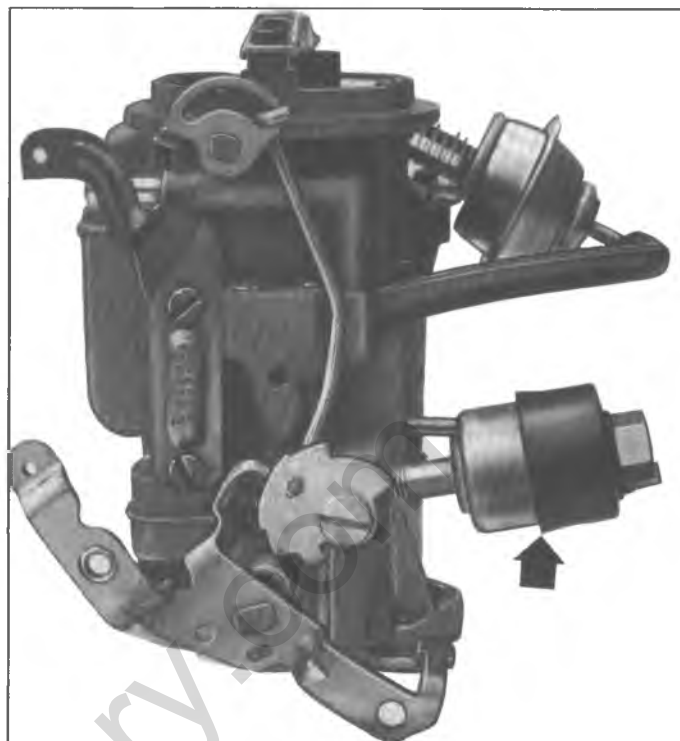

Fig. 5d—L-6 Idle Stop Solenoid

### Vacuum Advance Solenoid

The vacuum advance solenoid (fig. 6d) is bracket-attached to the ignition coil retaining screw. This electrically operated two-position plunger controlled valve serves to supply or deny vacuum to the distributor vacuum advance unit. In the energized position, the plunger opens the vacuum port from the carburetor to the vacuum advance unit. In opening the vacuum port the plunger simultaneously closes the clean air port at the opposite end. In the de-energized position the spring loaded plunger seats against the vacuum inlet and opens the distributor advance unit to the clean air vent.

The CEC solenoid (fig. 5d) is a two-position electrically operated control, which serves a dual function in the TCS system. In the de-energized position the spring loaded plunger closes the vacuum supply port to the distributor advance unit and opens the air vent to the advance unit. In the energized position the plunger is extended to contact the carburetor throttle lever and to open the vacuum port to the distributor and to shut off the air vent. The solenoid is bracket-attached to the carburetor so that the plunger, when extended, contacts the throttle lever to maintain a predetermined throttle opening.

### Time Relay

The time relay is an electrically operated on-off type switch. When the coil is energized it begins to heat the bi-metal strip to open the normally closed relay points in approximately 20 seconds. A ground path is provided through the relay housing and mounting bracket. Two self-tapping screws attach the relay to the upper portion

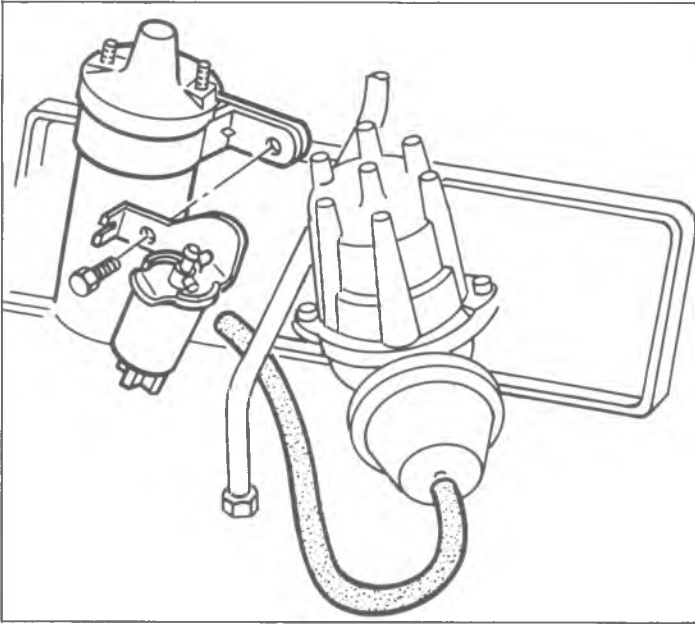

Fig. 6d—L-6 Vacuum Advance Solenoid

of the vertical wall of the cowl near the vehicle centerline.

### Temperature Cold Override Switch

The cold override switch, located in the thermostat housing (fig. 7d) serves to activate the vacuum advance solenoid. At coolant temperatures below 93 ( $\pm 5$ ) degrees, the cold terminal is contacted by the bi-metallic strip to ground and completes the circuit to the vacuum advance solenoid. In the neutral position, no contact is made; therefore the circuit is broken.

### Transmission Switch

On manual shift synchromesh transmissions, the switch is located on the outside of the transmission case in an area adjacent to the 2-3 shifter shaft (fig. 7d). The mechanically operated switch is spring loaded to provide continuity between the switch terminal and the switch housing. When installed in the transmission, the plunger

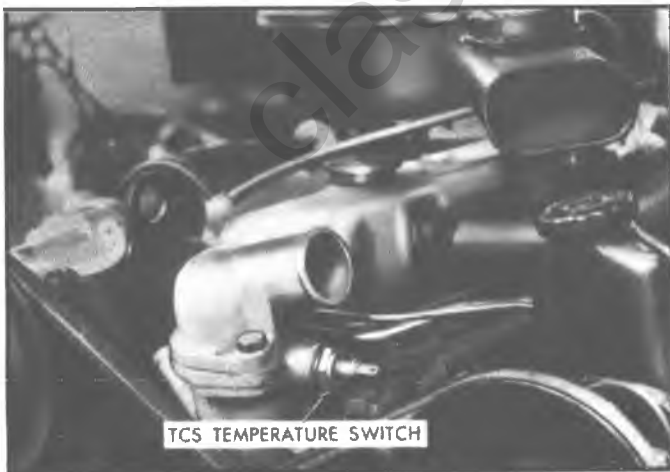

Fig. 7d—L-6 Temperature Cold Override Switch

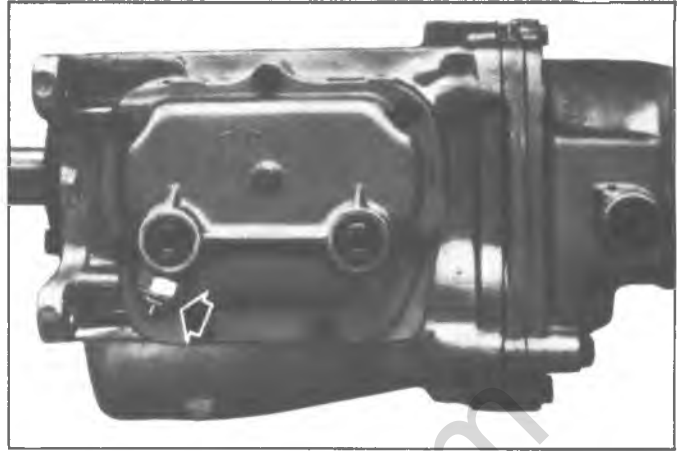

Fig. 8d—Transmission Switch Location (Manual)

contacts the shifter shaft, which causes the plunger to retract in low forward gears, thereby opening the circuit to ground. When the transmission is shifted into high forward gear, the plunger drops into a recess or flat on the shifter shaft, causing the plunger to rest internally on the switch housing. A circuit is completed to ground, from the transmission through the switch housing to the cup contact and through the spring to the electrical terminal.

## EIGHT-CYLINDER ENGINES

The Transmission Controlled Spark System is used on all 10 Series vehicles, C-K20 suburban, G20 Series and G30 Sportvans when equipped with manual transmission.

### DESCRIPTION

Control of exhaust emitted by vehicles using the eight-cylinder engines, is accomplished by eliminating ignition vacuum advance when the vehicle is operating in reverse, neutral or low forward gears.

Vacuum advance is controlled by a solenoid-operated switch, which is energized by grounding a normally open switch at the transmission. When the solenoid is in the non-energized position, vacuum to the distributor advance unit is denied and the distributor is vented to atmosphere through a filter at the opposite end of the solenoid — venting the distributor advance unit prevents it from becoming locked at an advanced position. When the solenoid is energized, the vacuum port is uncovered and the plunger is seated at the opposite end, shutting off the clean air vent.

The vacuum advance solenoid is controlled by two switches and a time relay. The solenoid is energized in the high forward gear by a transmission operated switch. A thermostatic coolant temperature switch is used to provide thermal override below 93°F.

Wider throttle blade openings at idle are required to compensate for the retarded spark condition produced by the design of the emission reduction system. To prevent engine dieseling at engine shut down, an idle stop solenoid is provided. The ignition switch activated idle stop solenoid eliminates dieseling tendencies by

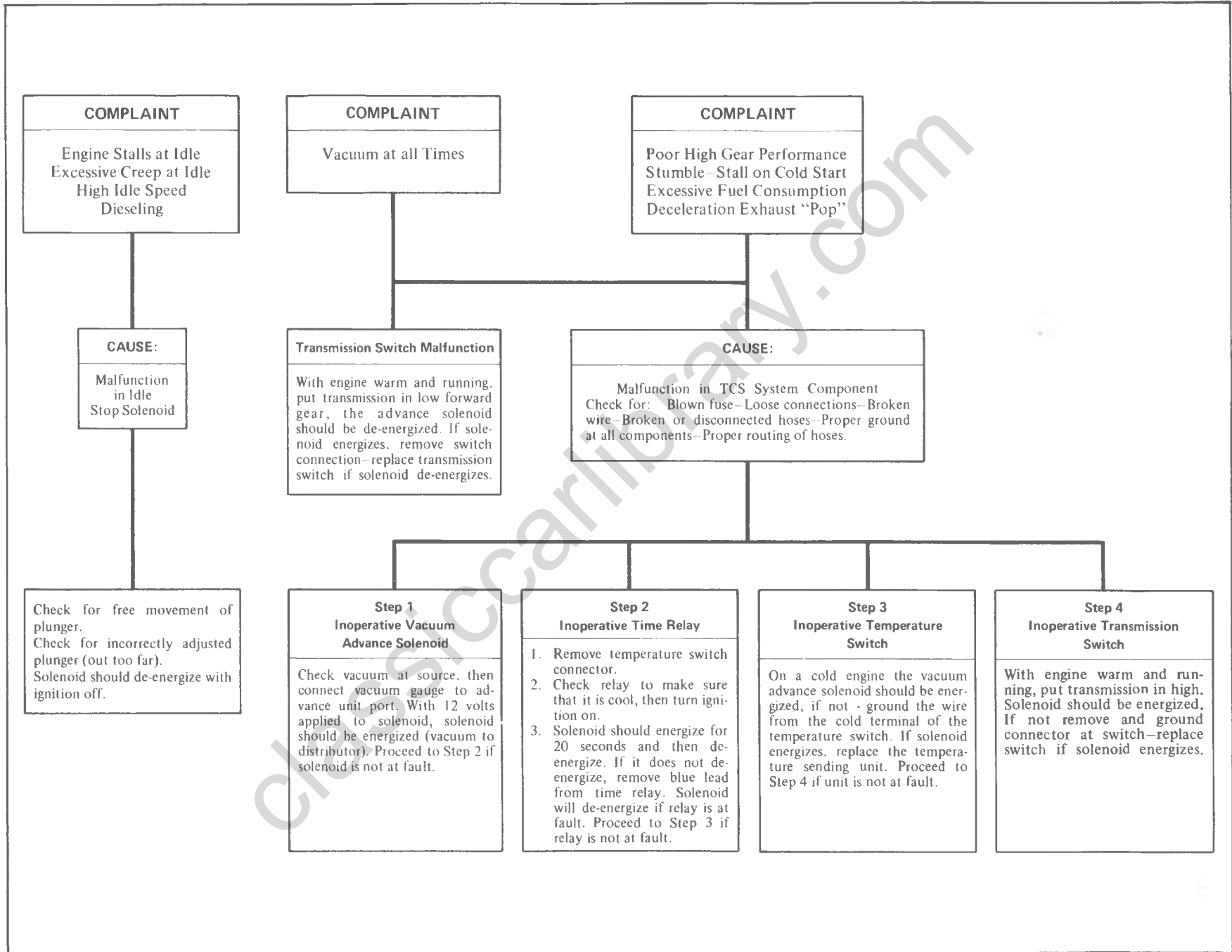

Fig. 9d—Trouble Shooting Guide (Six-Cylinder Engine with Manual Transmission)

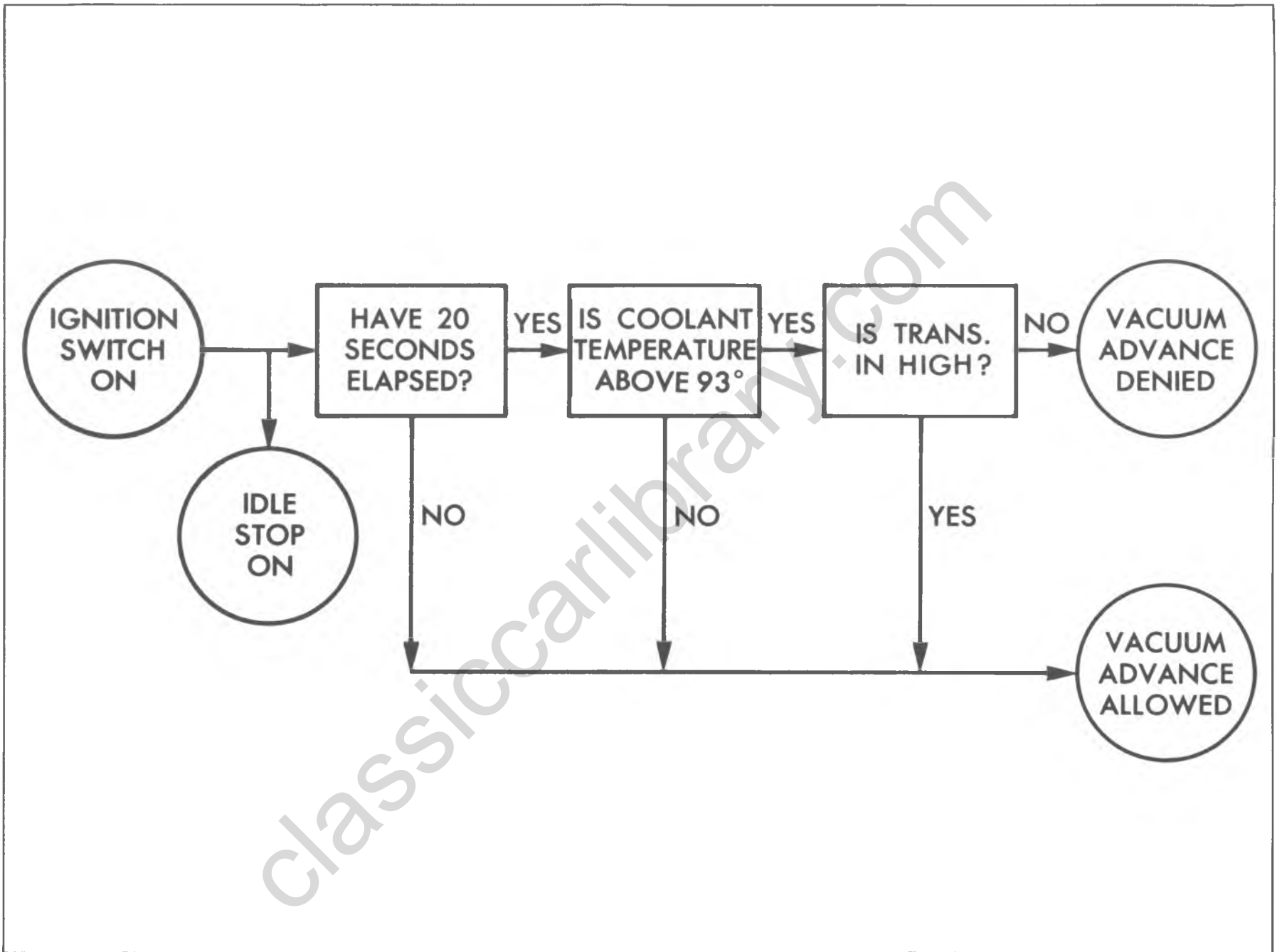

Fig. 10d—Vacuum Advance Diagram (Six-Cylinder Engine with Manual Transmission)



allowing the throttle valve to close beyond the normal idle position when the ignition is turned off.

### SYSTEM THEORY

The system components are shown in their normal at rest position with the engine off and cold (fig. 1e). The temperature switch points are closed, making contact with the cold terminal; the time relay points are closed; transmission switch points are open; idle stop solenoid is de-energized and plunger retracted; vacuum advance solenoid is de-energized with plunger shutting off the port to vacuum advance unit.

When the ignition switch is turned on, the idle stop solenoid is energized, extending the plunger to contact the throttle lever. A circuit is completed from the ignition switch through the vacuum advance solenoid and to ground through the temperature switch. At the same time another circuit is energized - this is from the ignition switch through the time relay coil and to ground, also as long as the relay points are closed, it provides a path to ground for the vacuum solenoid (fig. 2e).

With either one or both of the above circuits complete, the vacuum solenoid is energized permitting vacuum advance to the distributor.

In low gear operation, with engine temperature above 93 degrees, the temperature switch cold override points open (fig. 3e). If 20 seconds have elapsed, the time relay points are open also. This breaks the circuit(s) de-energizing the vacuum advance solenoid, allowing the plunger to block vacuum and open the advance unit to atmosphere.

When the transmission is shifted into high forward gear, the transmission switch points are closed by shift action. This completes the circuit from the ignition switch through the transmission switch to ground (fig. 4e). Vacuum advance solenoid is energized.

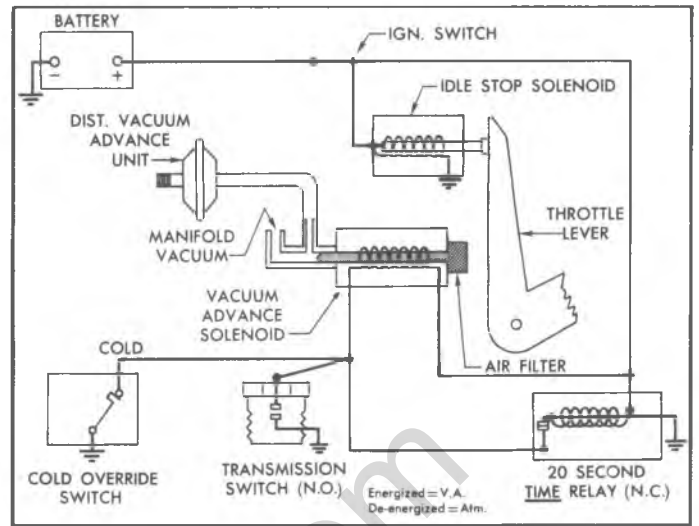

Fig. 2e-V8 TCS System (Cold Override Energized)

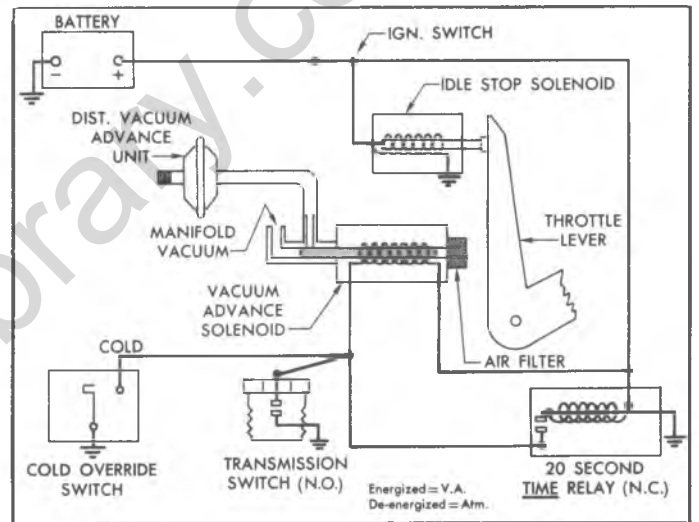

Fig. 3e-V8 TCS System (Low Gear Operation)

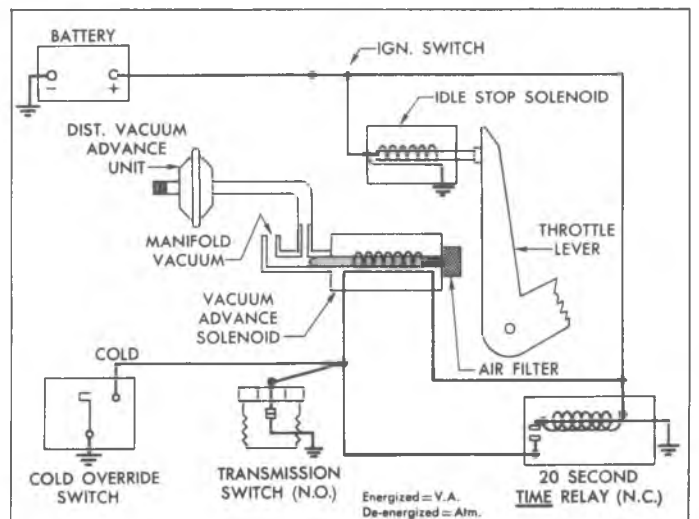

Fig. 4e-V8 TCS System (High Gear Operation)

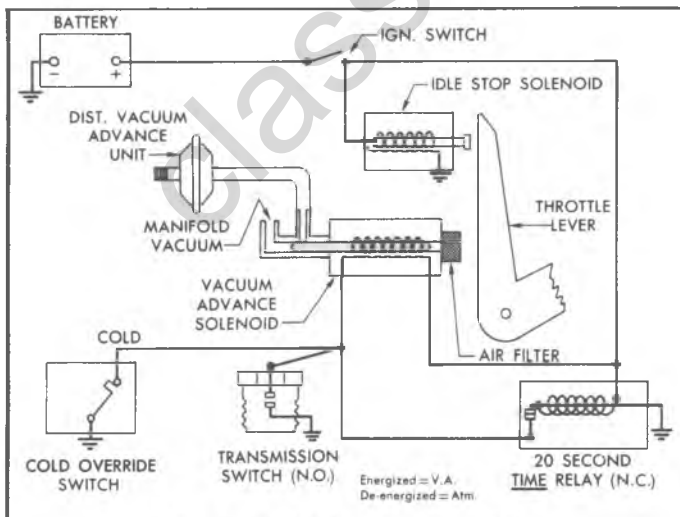

Fig. 1e-V8 TCS System (Engine Off)

## COMPONENT DESCRIPTION

### Idle Stop Solenoid

The idle stop solenoid (fig. 5e and 6e) is a two position electrically operated control, used to provide a predetermined throttle setting. In the energized position (plunger extended) the plunger contacts the carburetor throttle lever and prevents full closing of the carburetor throttle plates. This fast idle control when de-energized (plunger retracted) allows throttle plates to close beyond the normal idle position; thereby shutting off air supply and in essence starving the engine so that it will shut down without dieseling. The idle stop solenoid is bracket-attached to the carburetor so that the plunger, when extended, contacts the throttle lever.

### Vacuum Advance Solenoid

The vacuum advance solenoid is located on the right front portion of the inlet manifold on small V8 engines and at rear center of the inlet manifold on Mark IV V8 (fig. 7e and 8e). This electrically operated two-position plunger controlled valve serves to supply or deny vacuum to the distributor vacuum advance unit. In the energized position, the plunger opens the vacuum port from the carburetor to the vacuum advance unit. In opening the vacuum port the plunger simultaneously closes the clean air port at the opposite end. In the de-energized position the spring loaded plunger seats against the vacuum inlet and opens the distributor advance unit to the clean air vent.

### Time Relay

The time relay is an electrically operated on-off type switch. When the coil is energized, it begins to heat the bi-metal strip to open the normally closed relay points in approximately 20 seconds after the ignition switch is turned on. If the vehicle is not started within 20 seconds and the time relay has completed its "countdown", it denies vacuum advance until the relay has cooled. Once the relay has run one cycle after the ignition has been



Fig. 6e—Idle Stop Solenoid (4-Barrel Carburetor)

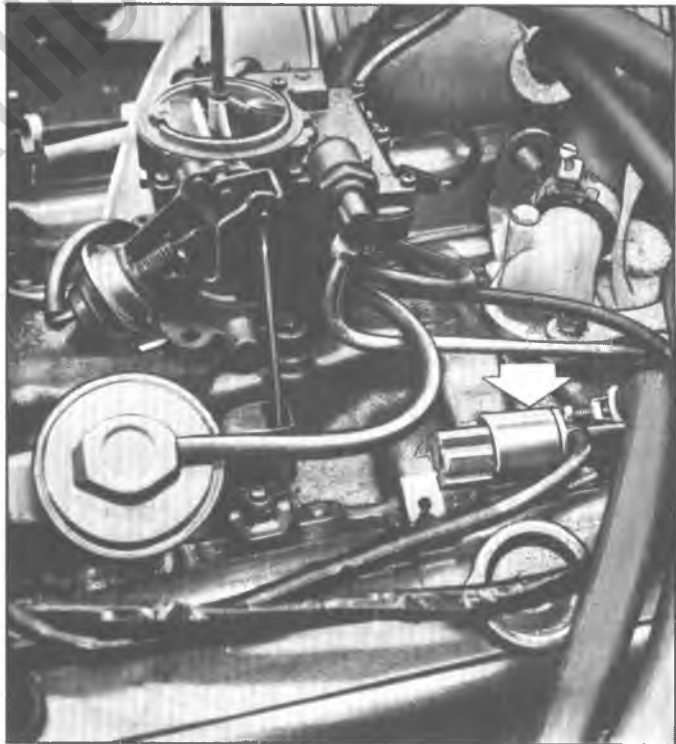

Fig. 7e—Small V8 Vacuum Advance Solenoid



Fig. 5e—Idle Stop Solenoid (2-Barrel Carburetor)

turned on, it must cool before it will reactivate even if the ignition is switched off and turned on.

A ground path is provided through the relay housing

and mounting bracket. Two self-tapping screws attach the relay to the upper vertical wall of the cowl at or near centerline of the vehicle (fig. 9e).

### Temperature Switch

The TCS system temperature switch is located in the right cylinder head between the number 6 and number 8 exhaust port (fig. 10e).

The switch is a two-position single terminal control which provides a path to ground, for the cold override feature, when engine coolant temperatures are below 93 degrees. The "off" or "neutral" position is maintained at engine coolant temperatures above 93 degrees.

### Transmission Switch

On manual shift synchromesh transmissions, both 3-and 4-speed, the switch is located on the outside of the transmission case in an area adjacent to the 2-3 or 3-4 shifter shaft, as applicable (fig. 11e). The mechanically operated switch is spring loaded to provide continuity between the switch terminal and the switch housing. When installed in the transmission, the plunger contacts the shifter shaft, which causes the plunger to retract in low forward gears, thereby opening the circuit to ground. When the transmission is shifted into high forward gear, the plunger drops into a recess or flat on the shifter shaft, causing the plunger to extend and allow the cup contact to rest internally on the switch housing. A circuit is completed to ground, from the transmission through the switch housing to the cup contact and through the spring to the electrical terminal.

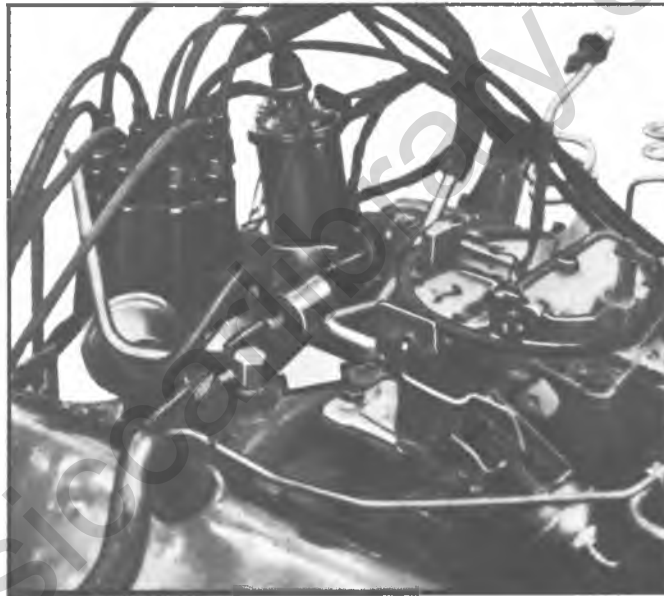

Fig. 8e—Mark IV V8 Vacuum Advance Solenoid

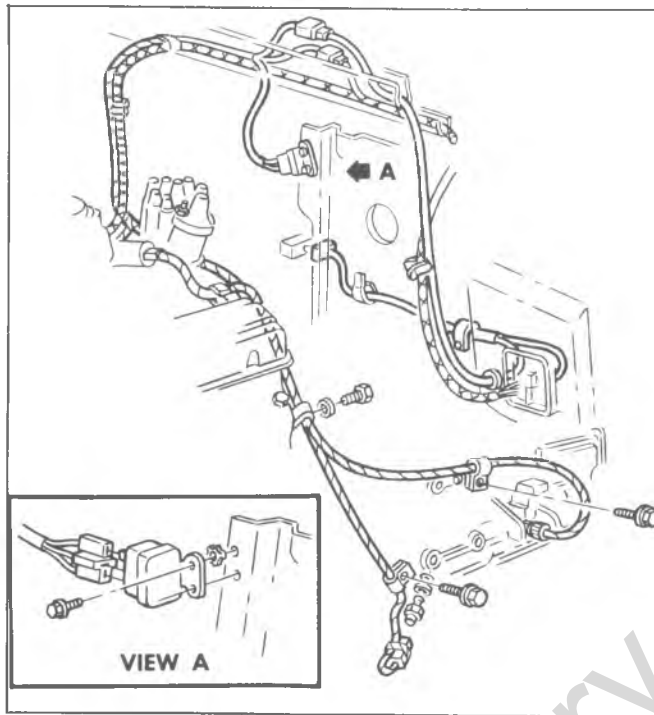

Fig. 9e—TCS Time Relay Location



Fig. 10e—Small V8 Temperature Switch (Right Head)

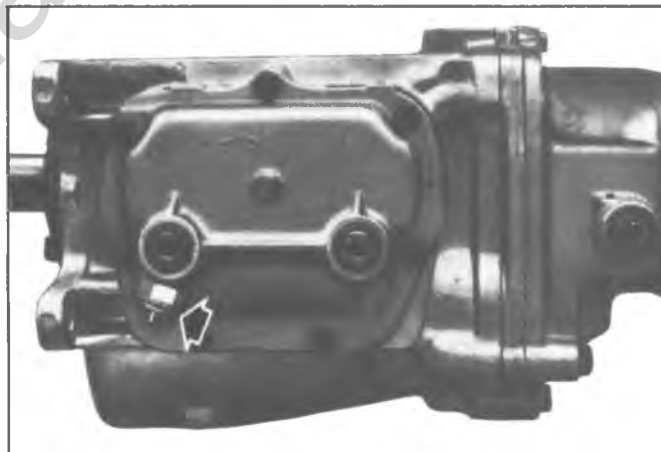

Fig. 11e—Transmission Switch Location (Manual)

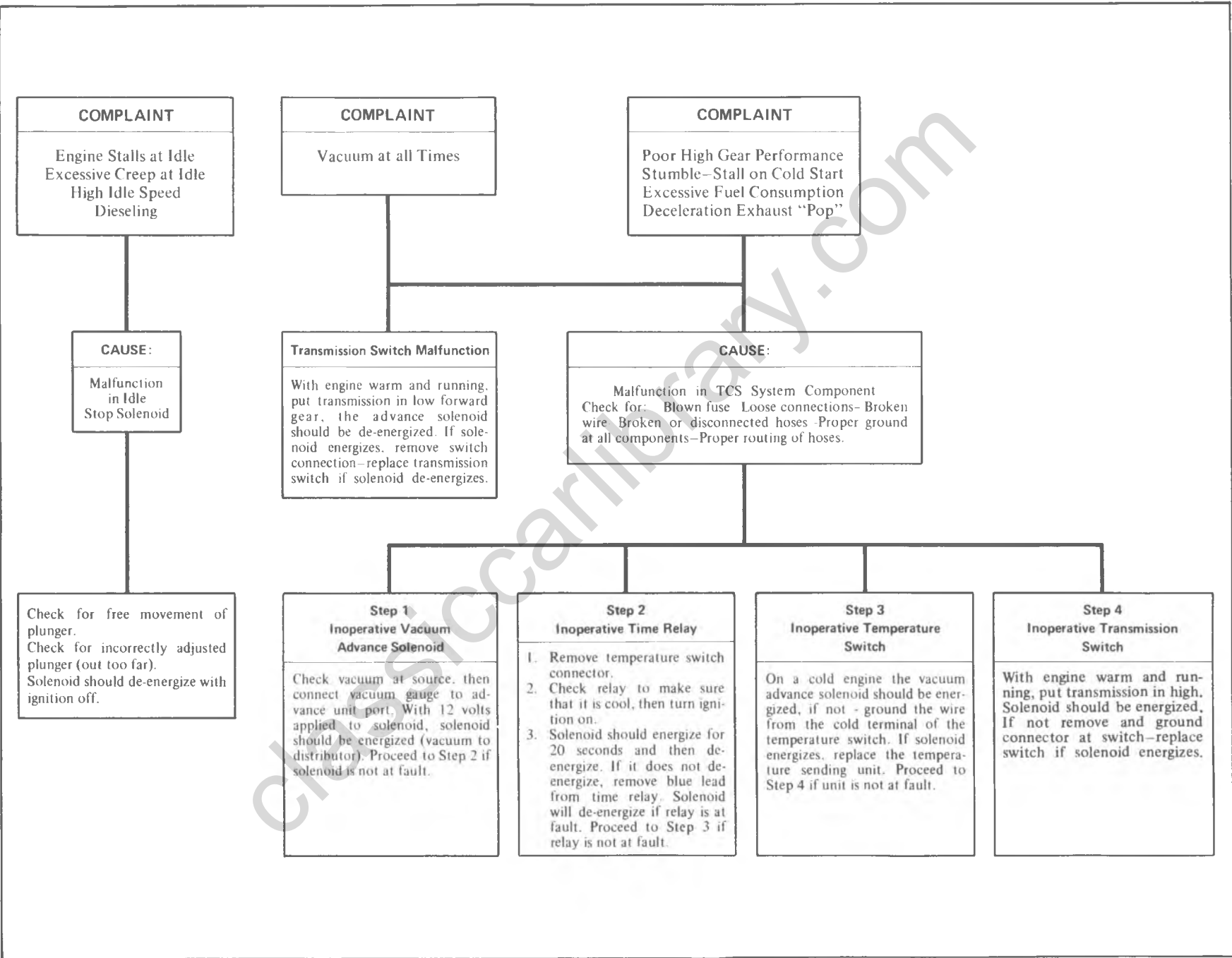

Fig. 12e—Trouble Shooting Guide (V8 Engine with Manual Transmission)

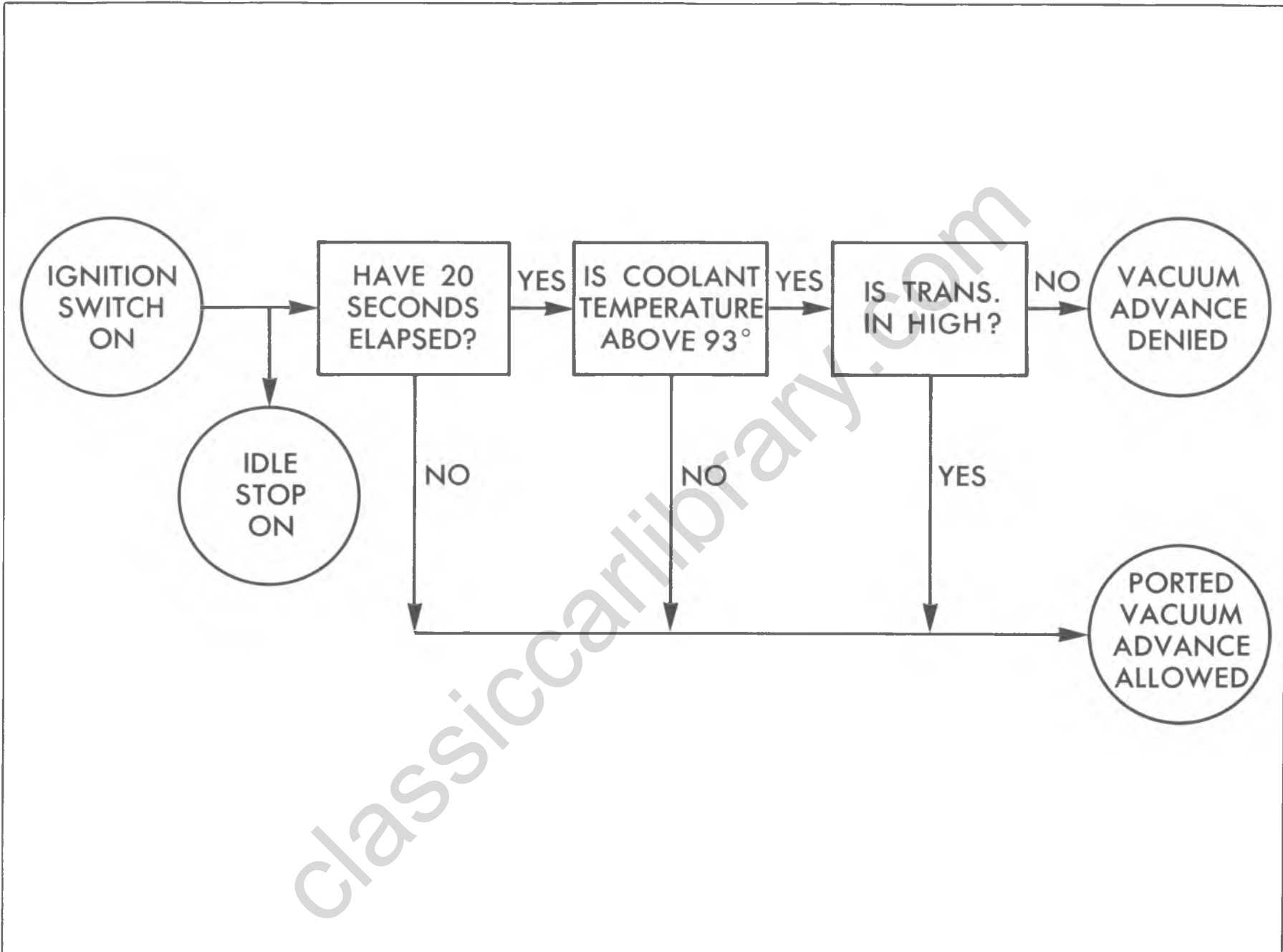

Fig. 13e—Vacuum Advance Diagram (V8 Engine with Manual Transmission)

# AIR INJECTION REACTOR SYSTEM

## INDEX

General Description.....	6T-21	Check Valve(s) .....	6T-31
Theory of Operation .....	6T-24	Inspection .....	6T-31
Maintenance Procedures .....	6T-28	Replacement.....	6T-31
Drive Belt.....	6T-28	Diverter Valve.....	6T-31
Inspection .....	6T-28	Inspection .....	6T-31
Adjustment .....	6T-28	Replacement.....	6T-31
Replacement.....	6T-28	Air Injection Tube .....	6T-32
Pump Pulley .....	6T-29	Inspection .....	6T-32
Replacement.....	6T-29	Replacement.....	6T-32
Air Pipe Hose and Tube .....	6T-30	Air Injection Pump.....	6T-32
Inspection .....	6T-30	Inspection .....	6T-32
Replacement.....	6T-30	Pressure Relief Valve.....	6T-33
		Diagnosis .....	6T-33

## GENERAL DESCRIPTION

The Air Injection Reactor (A.I.R.) System (figs. 1f, 2f and 3f), consists of: the air injection pump (with necessary brackets and drive attachments), air injection tubes (one for each cylinder), an air diverter valve, check valves (one for in-line engines, two for V8 engines) and air pipe assemblies, and hoses necessary to connect the various components.

Carburetors and distributors for engines with the A.I.R. System are designed, particularly, for these engines; therefore they should not be interchanged with or replaced by a carburetor or distributor designed for engines without the A.I.R. System.

When properly installed and maintained, the A.I.R. System will effectively reduce exhaust emissions.

However, if any A.I.R. component or any engine component that operates in conjunction with the A.I.R. System should malfunction, the exhaust emissions might be increased.

Because of the relationship between "Engine Tune Up" and "Unburned Exhaust Gases", the condition of the Engine Tune Up should be checked whenever the A.I.R. System seems to be malfunctioning. Particular care should be taken in checking items that affect fuel-air ratio such as the crankcase ventilation system, the carburetor and the carburetor air cleaner.

Because of the similarity of many parts, typical illustrations and procedures are used except where specific illustrations or procedures are necessary to clarify the operation.

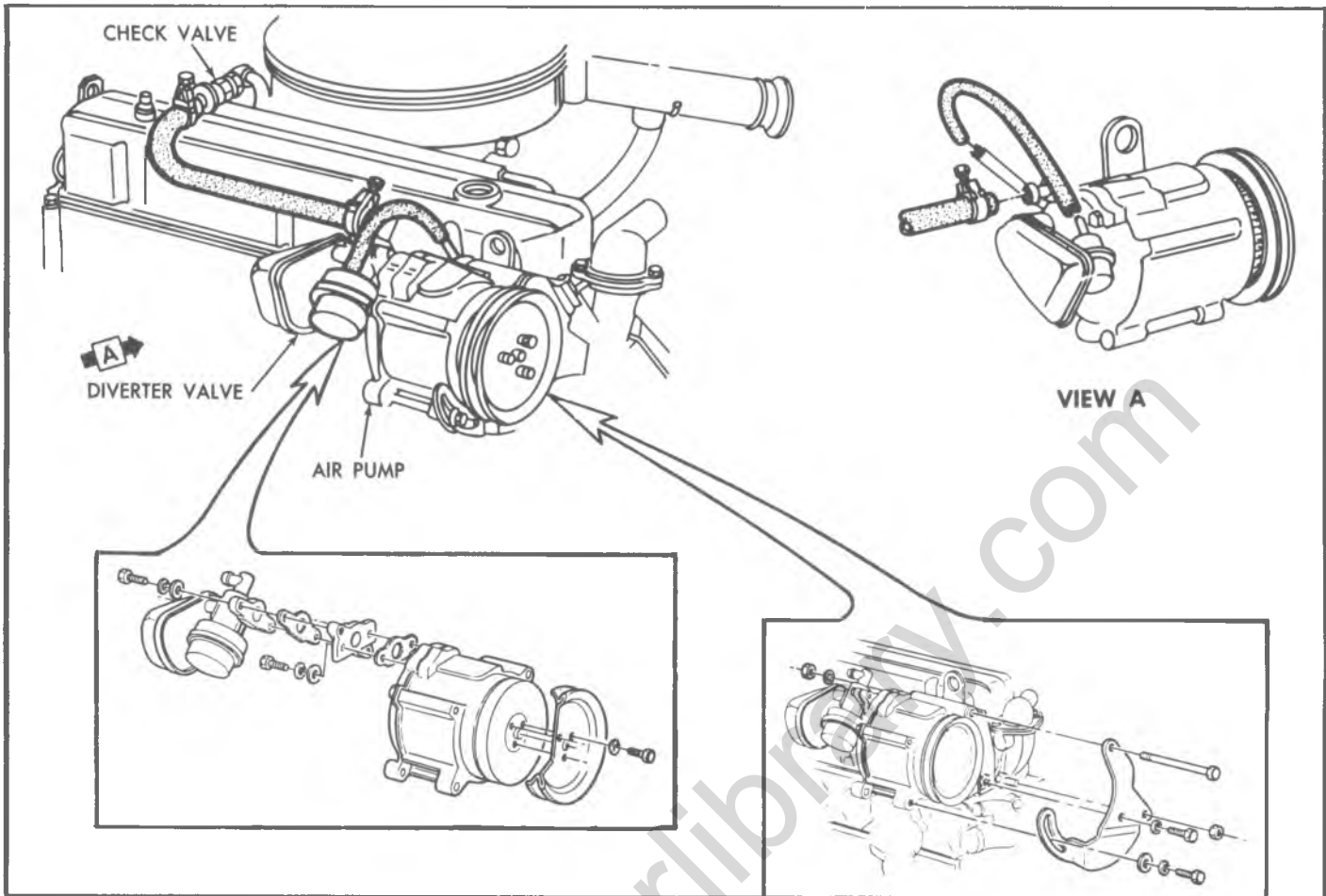

Fig. 1f—Six-Cylinder A.I.R. System

classiccarlibrary.com



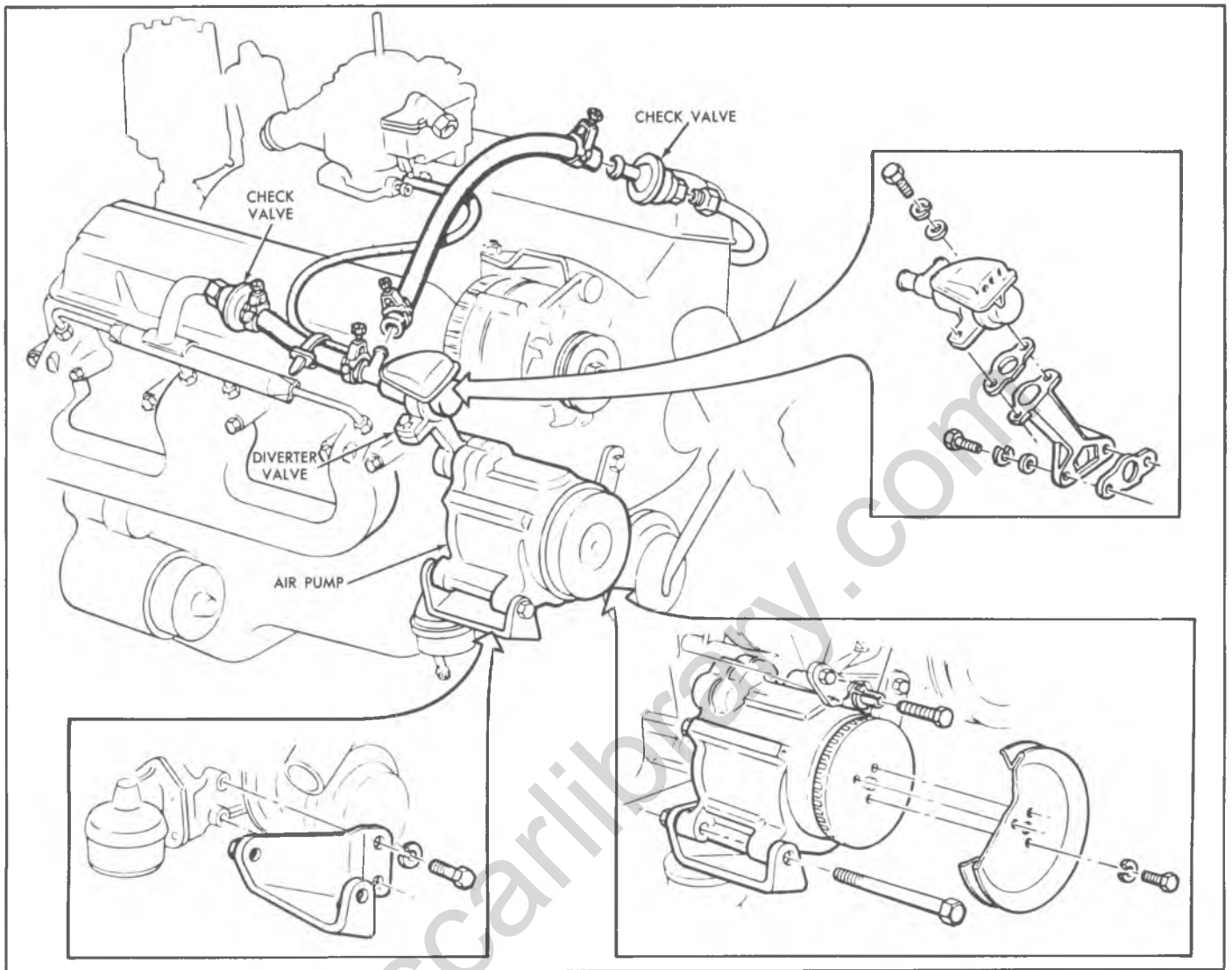

Fig. 2f—Eight-Cylinder A.I.R. System (Except G Series)

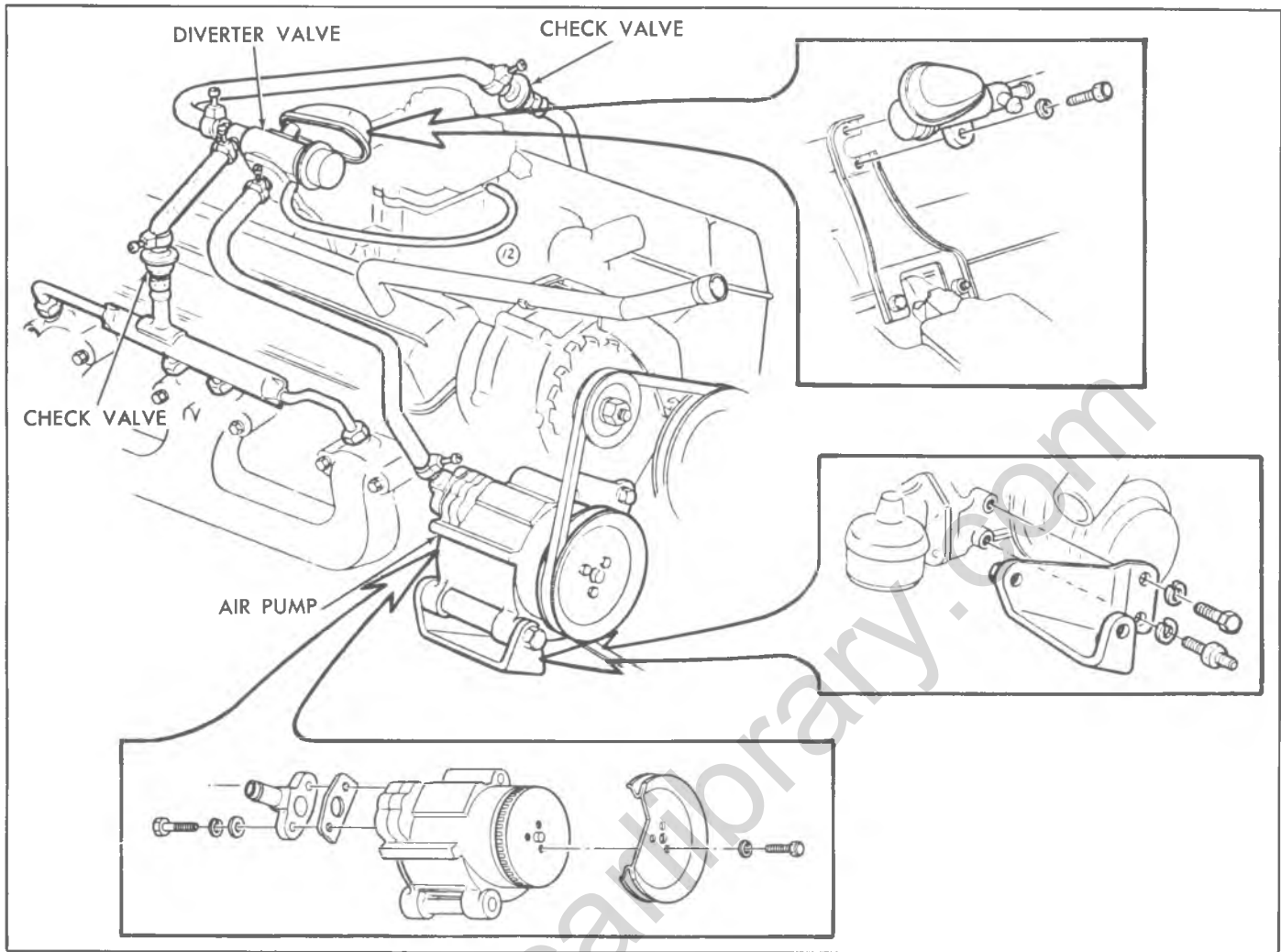

Fig. 3f—Eight-Cylinder A.I.R. System (G Series)

## THEORY OF OPERATION

The Air Injector Reactor (A.I.R.) system (Fig. 4f) is an exhaust emission system that is used to actually burn the unburned portion of the exhaust gases to reduce its hydrocarbon and carbon monoxide content. The system is primarily composed of an air pump, diverter valve, check valve(s), air pipe assemblies and connecting hoses and fittings.

Air is drawn into the air pump, where it is compressed. The compressed air is fed out of the pump through the diverter valve and check valve (operation of these valves will be discussed in later paragraphs) into the combustion pipe assemblies (Fig. 5f). The air pipe assemblies route the compressed air into the exhaust manifolds (V-8 engines) or cylinder head exhaust ports (L-6 engines). When this compressed air mixes with the hot exhaust gases in the cylinder head or exhaust manifold, combustion results. This combustion process burns most of the unburned hydrocarbon and carbon monoxide in the exhaust before it leaves the vehicle

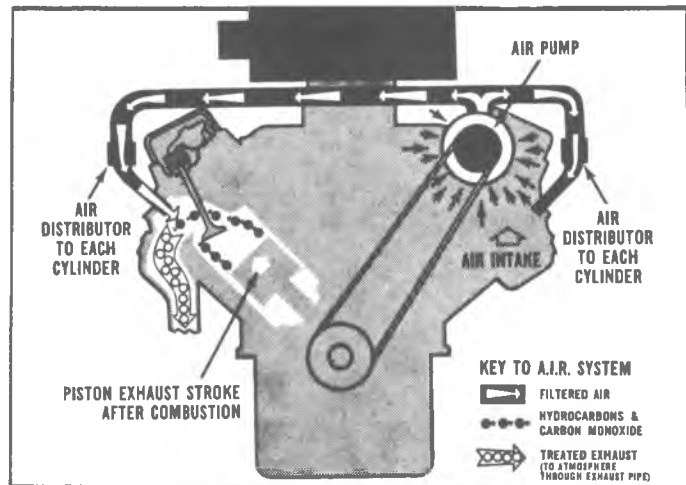

Fig. 4f—Schematic of A.I.R. System

through the exhaust system. Thus, the exhaust emitted at the tail pipe is low in hydrocarbon and carbon monoxide content.

Burning the unburned portion of the exhaust gases is much like fanning dying embers. When the gases leave the cylinders, they are extremely hot and still flammable if supplied with the other element of combustion - namely oxygen. This oxygen is supplied in the air being supplied by the pump (Fig. 6f). If oxygen is not supplied to this mixture when it first leaves the cylinders, the gases cool down to a non-flammable mixture by the time they enter the exhaust system.

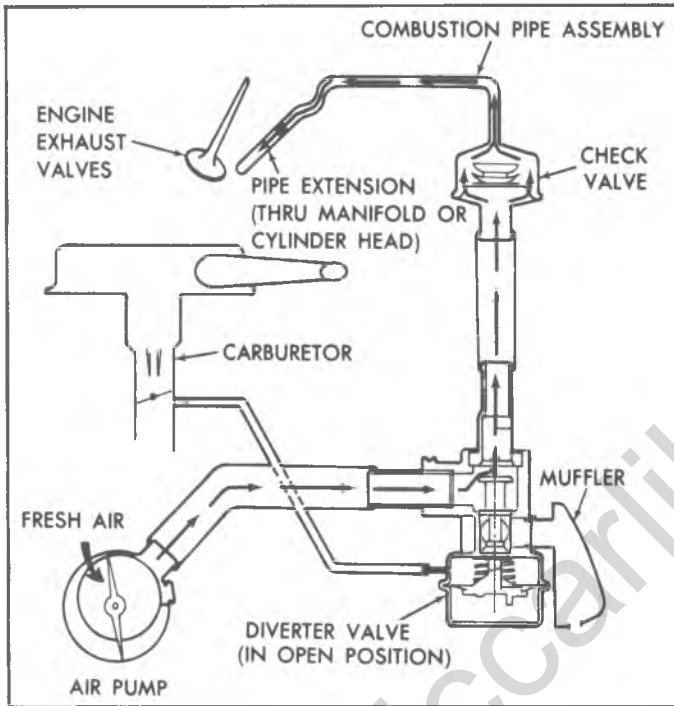

Fig. 5f—A.I.R. System Operation

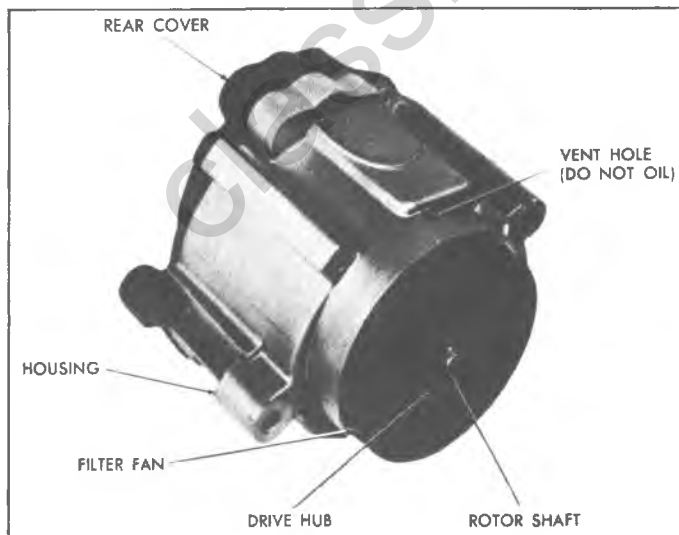

Fig. 6f—Air Injection Pump

One problem with such a system, however, is that during engine overrun or deceleration, the exhaust gases in the exhaust valve area are overly rich with fuel vapors. If this system was allowed to operate under this condition, a sizable backfire would result as soon as the fresh air from the pump mixed with the overly rich vapor. To eliminate this possibility, a diverter valve has been incorporated into the system.

The diverter valve is triggered by sharp rises in vacuum - the vacuum signal is taken from just beneath the carburetor throttle plate. When a sharp rise in vacuum is sensed, as during engine overrun, the diverter valve exhausts the air pump out-put into the atmosphere for a few seconds (Fig. 7f). Since the compressed air from air pump never reaches the air manifolds - no backfire occurs.

The check valves used in this system are nothing more than one-way valves which prevent exhaust gases from entering and damaging the air injection pump, if for any reason (such as drive-belt failure) the pump becomes inoperative. Under normal operating conditions, air pressure from the pump is sufficient to prevent exhaust gases from entering the pump.

One (1) check valve is used per air pipe assembly. L-6 engines use one air pipe assembly and thus one check valve. V-8 engines use two air pipe assemblies (one per bank) and thus two (2) check valves.

### AIR PUMP

The 2-vane pump is used in all applications to compress the fresh filtered air and inject it into the exhaust manifold or cylinder head. Pump components and operation are described in the following text.

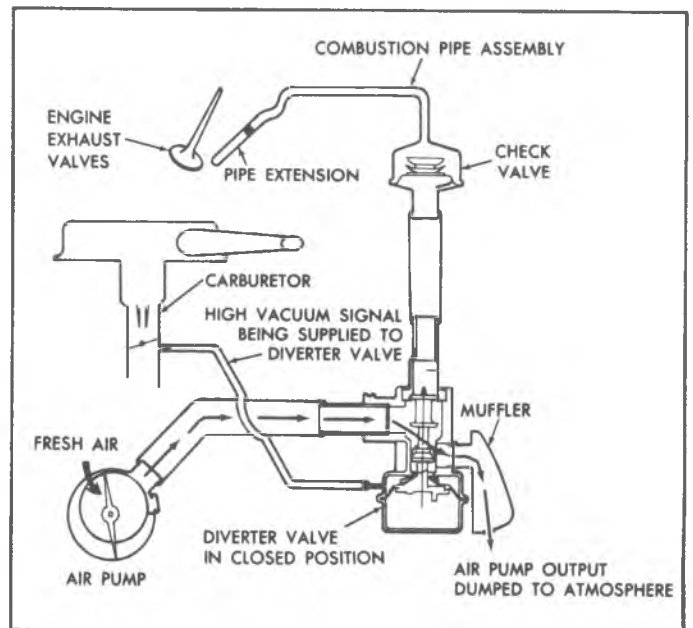

Fig. 7f—Diverter Valve Operation

**Pump Components (Fig. 8f)**

1. Pump housing.
2. Centrifugal filter.
3. Set (2) of vanes which rotate about the centerline of pump housing bore.
4. Rotor which rotates on axis that is different than the centerline of the pump bore or the axis of vane rotation. The rotor drives the vanes and is driven by the pump pulley.
5. Set of seals (two per vane) which provide sealing between the vanes and rotor.

The pump vanes are located 180° apart and are in constant contact (or rather near contact) with the pump housing bore. The vanes are driven by the rotor and slide through the slits in the rotor.

As the vane rotates past the inlet port, it provides an increasing volume which has the effect of producing a vacuum which draws air into the pump (Fig. 9f).

As the vane continues to rotate the other vane has also passed the inlet port. At this point, the air that was drawn into the pump is entrapped between these two vanes. As the vanes continue to rotate the entrapped air is carrier into a smaller volume and thus compressed.

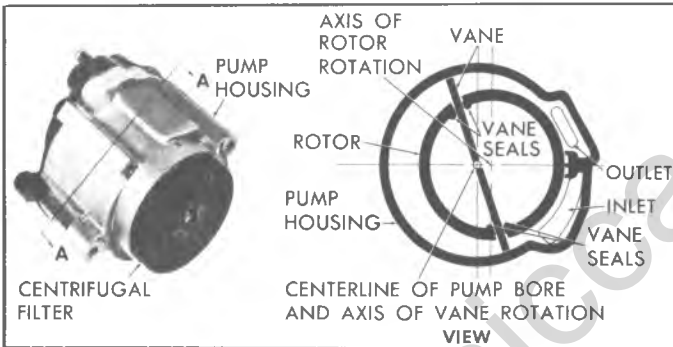

Fig. 8f—Air Injection Pump Components

Continuing rotation takes the vane past the outlet port. Once the vane is past the outlet port, the compressed air is exhausted out the port into the remainder of the system.

Although the discussion has been concentrated on only one cycle, it should be noted that actually two cycles are made with every complete revolution.

As mentioned, the two-vane pump uses a centrifugal filter to clean the air as it enters the inlet port of the pump. This centrifugal filter actually opposes air entry into the pump but is not efficient enough to hamper it. This opposing force does, however, discharge any foreign particles in the air from entering the pump.

The air enters the pump by passing past the vanes of the centrifugal filter. The vanes of the filter are being rotated at a relatively high r.p.m. These rotating vanes hit any foreign particles in the air trying to enter the pump and rebound them out and away from the pump (Fig. 10f).

**DIVERTER VALVE**

The purpose of the diverter valve in the system is to momentarily exhaust (divert) the air pump output so that it does not reach the exhaust valve area during the initial stages of engine overrun (Fig. 11f). During engine overrun; there is a high vacuum state just beneath the carburetor throttle plate drawing rich mixtures of fuel into the cylinders. This rich mixture cannot be completely burned in the power stroke so much of it is exhausted out the exhaust valves. If air from the pump was allowed to combine with this mixture, a backfire would occur. The diverter valve diverts the air pump output at this time as follows:

During normal operation, the diverter valve is in the open position.

In this position, air pump output is simply routed through the valve into the remainder of the system. However, during engine overrun, a strong vacuum signal (taken from just below the carburetor throttle plate) is

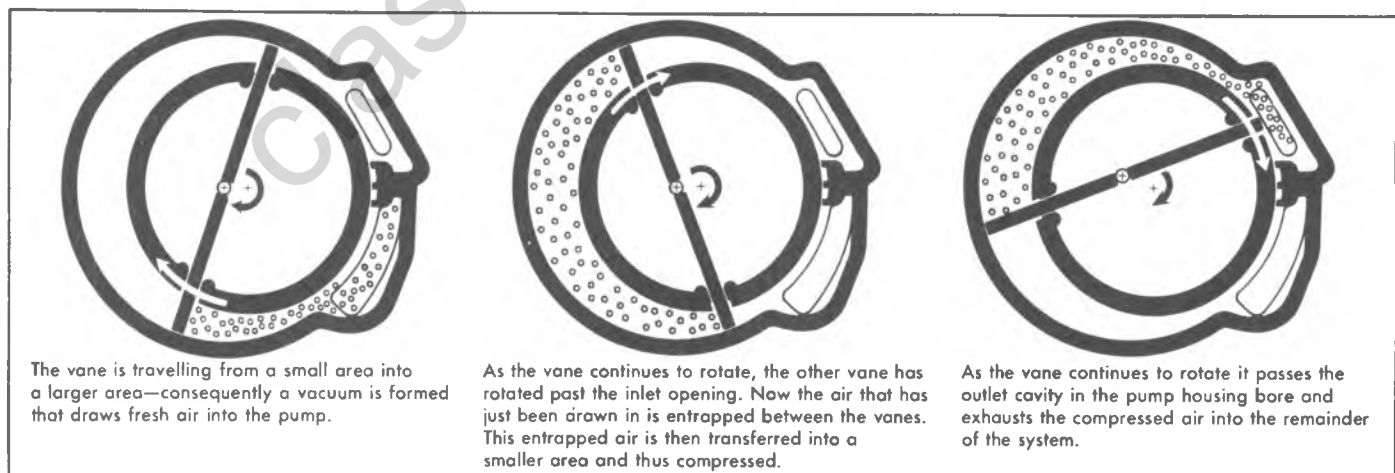

Fig. 9f—Air Injection Pump Operation

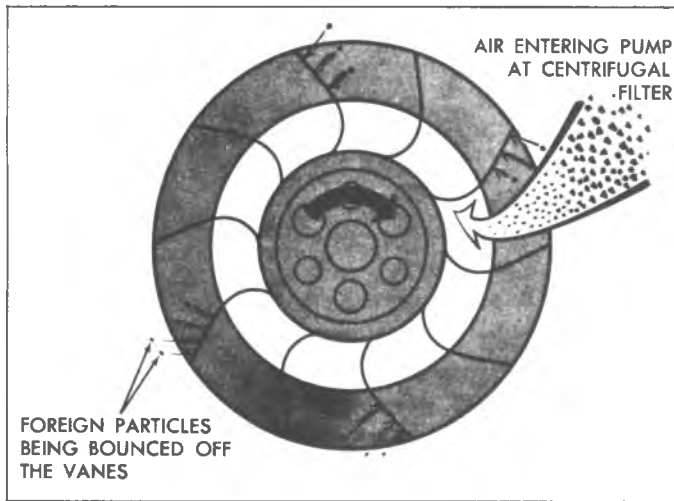

Fig. 10f—Centrifugal Filter Operation

sent to the diverter valve diaphragm. This vacuum signal is strong enough at this point to overcome the spring force opposing the diaphragm action. Consequently, the diaphragm is pulled up against the spring. The spool valve of the diverter valve is connected directly to the diaphragm so it too moves up and seats in the upper

seat. This, then, shuts off the passage into the remainder of the system while at the same time opens a path that exhausts the air pump output through the muffler to the atmosphere.

A pressure relief valve is incorporated in the diverter valve to relieve excessive pump pressure. The valve body encloses a preload spring, valve and valve seat. When air pressure in the pump builds up to a predetermined value, it forces the valve off its seat compressing the spring and dumps pump pressure to atmosphere. The pressure at which the valve opens is determined by the resistance (preload) of the spring.

### Check Valves and Air Pipe Assemblies

One check valve is used on each air pipe assembly. The air pipe assembly(s) route the air pump output to each cylinder in the area of the exhaust valves. L-6 engines used one (1) air pipe assembly and one (1) check valve. V-8 engines use two air pipe assemblies (one per bank) and two check valves (fig. 12f).

The check valve(s) are nothing more than one way valve(s) that allow air flow through them in the direction of the exhaust valves but stop flow through them in the direction of the air pump. This keeps any of the exhaust gases from entering the pump.

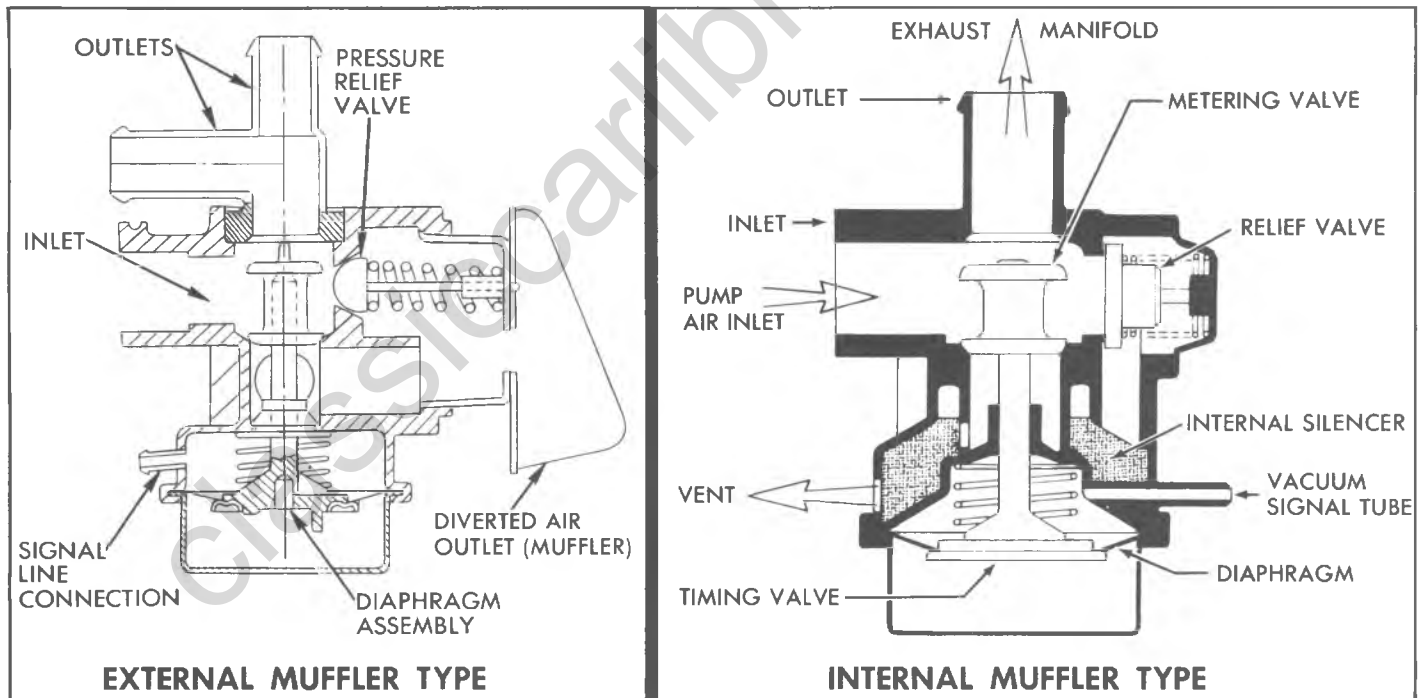

Fig. 11f—Diverter Valve Components

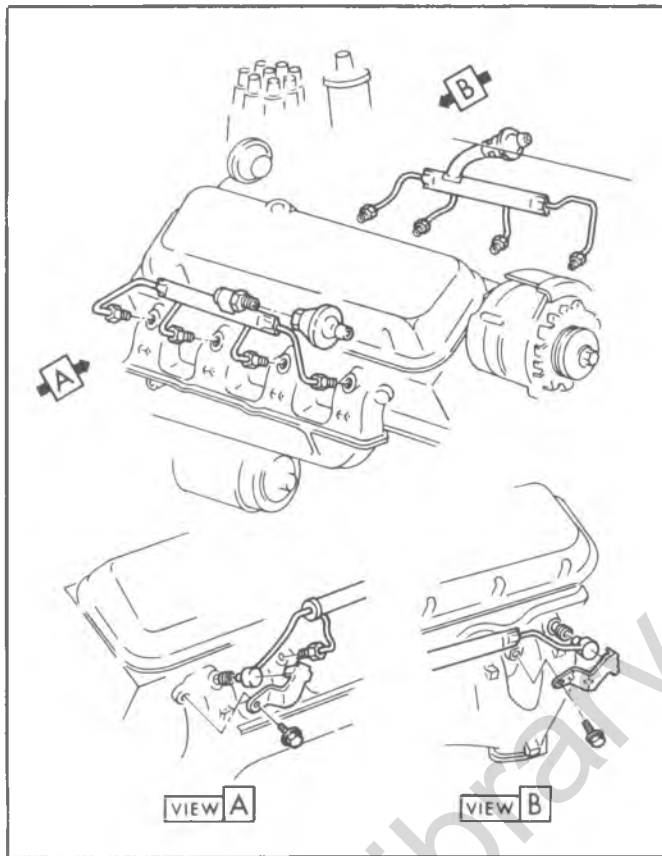

Fig. 12f—Air Injection Tubes (Mark IV V8)

## MAINTENANCE PROCEDURES

### Drive Belt

#### Inspection

- Inspect drive belt for wear, cracks or deterioration and replace if required.
- Inspect belt tension and adjust if below 50 lbs. using a strand tension gauge.

#### Adjustment

- Loosen pump mounting bolt and pump adjustment bracket bolt or Delcotron mounting bolt and adjustment bracket as applicable.

- Move pump or Delcotron until belt is properly tensioned then tighten adjustment bracket bolt and mounting bolt. Use a strand tension gauge to check adjustment (fig. 13f).

**CAUTION:** Do not pry on the pump housing. Distortion of the housing will result in extensive damage to the Air Injection Pump.

#### Replacement

- Loosen pump mounting bolt and pump adjustment bracket bolt or Delcotron as applicable, then swing pump until drive belt may be removed.
- Install a new drive belt and adjust as outlined above.

## Pump Pulley

### Replacement

- Hold pump pulley from turning by compressing drive belt then loosen pump pulley bolts.
- Remove drive belt as outlined above then remove pump pulley.
- Install pump pulley with retaining bolts hand tight.
- Install and adjust drive belt as outlined above.
- Hold pump pulley from turning by compressing drive belt then torque pump pulley bolts to 80 lb. in. (fig. 14f).
- Recheck drive belt tension and adjust if required.

## Pump Filter

### Replacement

- Remove drive belt and pump pulley as previously outlined.
- Pry loose outer disc of filter fan.

- Pull filter off with pliers (fig. 15f).

NOTE: Care should be taken to prevent fragments from entering the air intake hole.

- Install the new filter by drawing it on with the pulley and pulley bolts (fig. 16f). Do not attempt to install a filter by hammering it on or pressing it on.



Fig. 14f—Tightening Pump Pulley Bolts



Fig. 13f—Checking A.I.R. Pump Belt Tension

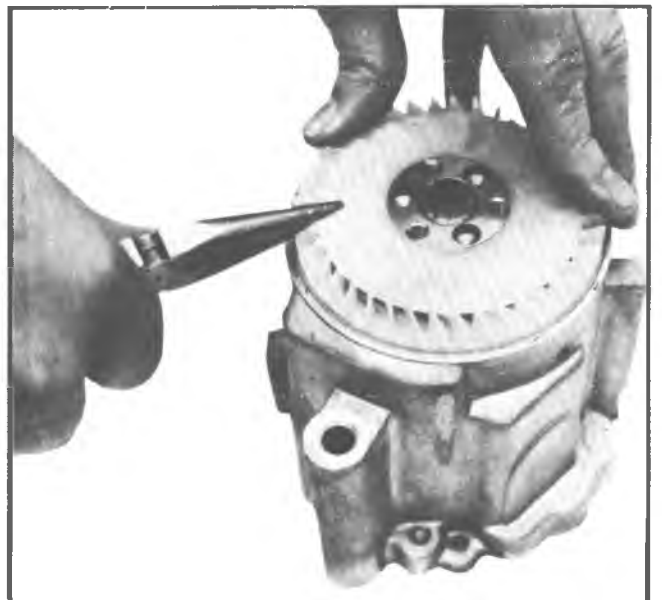

Fig. 15f—Removing Centrifugal Filter



Fig. 16f—Installing Centrifugal Filter

- Draw the filter down evenly by alternately torquing the bolts. Make certain that the outer edge of the filter slips into the housing. The slight amount of interference with the housing bore is normal.

NOTE: A new filter may squeal upon initial operation until its O.D. sealing lip has worn in.

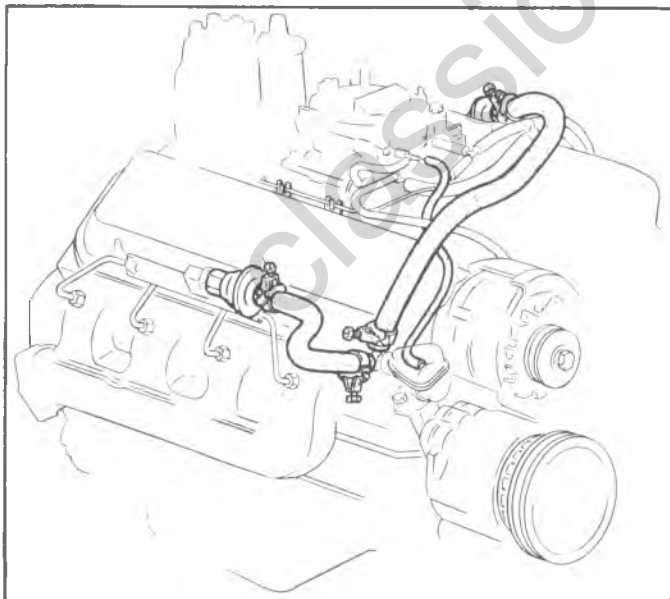

Fig. 17f—Mark IV V8 A.I.R. Hoses

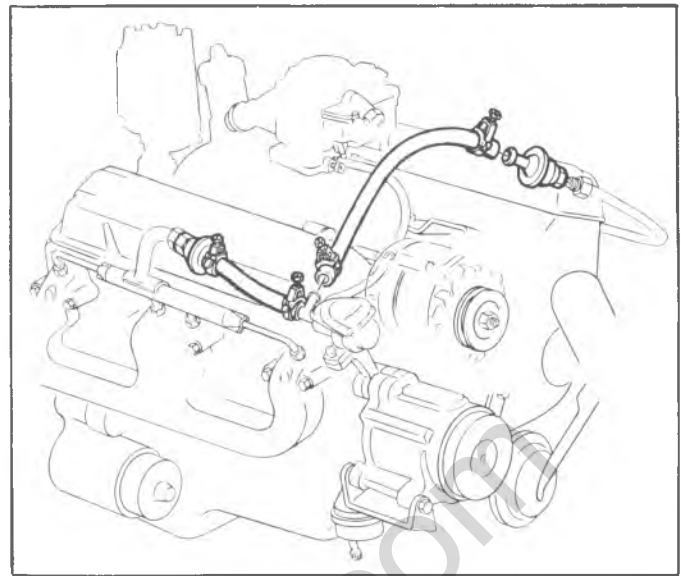

Fig. 18f—Small V8 A.I.R. Hoses

## Air Manifold, Hose and Tube

### Inspection

- Inspect all hoses for deterioration or holes.
- Inspect all tubes for cracks or holes.
- Check all hose and tube connections.
- Check all tube and hose routing (fig. 17f and 18f). Interference may cause wear.
- If leak is suspected on the pressure side of the system or any tubes and/or hoses have been disconnected on the pressure side, the connections should be checked for leaks with a soapy water solution.
- With the pump running, bubbles will form if a leak exists (fig. 19f).

### Replacement

- To replace any hose and/or tube, note routing then remove hose(s) and/or tube(s) as required.

**CAUTION:** The 1/4" pipe threads at the cylinder head on L-6 or the exhaust manifolds on V8 are a straight pipe thread. Do not use a 1/4" tapered pipe tap. The hoses of the A.I.R. System are a special material to withstand high temperature. No other type hose should be substituted.



- Install new hose(s) and/or tube(s), routing them as when removed.
- Tighten all connections.

NOTE: Use anti seize compound on threads of the air manifold to exhaust manifold or cylinder connections.

## Check Valve

### Inspection

- The check valve should be inspected whenever the hose is disconnected from the check valve or whenever check valve failure is suspected. (A pump



Fig. 19f—Checking for Leaks With a Soapy Water Solution



Fig. 20f—Air Flow Through Check Valve

that had become inoperative and had shown indications of having exhaust gases in the pump would indicate check valve failure.)

- Orally blow through the check valve (toward air manifold) then attempt to suck back through check valve. Flow should only be in one direction (toward the air manifold) (fig. 20f).

### Replacement

- Disconnect pump outlet hose at check valve. Remove check valve from air manifold, being careful not to bend or twist air manifold (fig. 21f).

## Diverter Valve

### Inspection

- Check condition and routing of all lines especially the signal line. All lines must be secure, without crimps and not leaking.
- Disconnect signal line at valve. A vacuum signal must be available with engine running (fig. 22f).
- With engine stabilized at idle speed, no air should be escaping through the muffler. Manually open and quickly close the throttle, a momentary blast of air should discharge through muffler for at least one second (fig. 23f).
- Defective valves should be replaced.

**CAUTION:** *Diverter valves although sometimes similar in appearance are designed to meet particular requirements of various engines, therefore, be sure to install the correct valve.*

### Replacement

- Disconnect vacuum signal line. Disconnect valve exhaust hose(s).
- Remove diverter valve from pump or elbow.



Fig. 21f—Removing Check Valve

## 6T-32 EMISSION CONTROL SYSTEMS

- Install diverter valve to pump or elbow with new gasket. Torque valve attaching screws to 85 in. lbs.
- Install outlet and vacuum signal lines and check system for leaks.

### Air Injection Tube

#### Inspection (Fig. 24f)

- There is no periodic service or inspection for the air injection tubes, yet on in-line engines whenever the cylinder head is removed or on V8 engines whenever the exhaust manifolds are removed, inspect the air injection tubes for carbon build up and warped or burned tubes.
- Remove any carbon build up with a wire brush.
- Warped or burned tubes must be replaced.

#### Replacement

- On in-line engines remove carbon from tubes and using penetrating oil, work tubes out of cylinder head.
- On V8 engines clamp exhaust manifold in a vise, remove carbon from tubes and using penetrating oil, work tubes out of manifold.

### Air Injection Pump

#### Inspection

Accelerate engine to approximately 1500 RPM and observe air flow from hose(s). If air flow increases as engine is accelerated, pump is operating satisfactorily. If air flow does not increase or is not present, proceed as follows:

- Check for proper drive belt tension.
- Check for a leaky pressure relief valve. Air may be heard leaking with the pump running.



Fig. 22f—Checking for Vacuum Signal at Diverter Valve



Fig. 23f—Momentary Blast of Air Through Diverter Valve  
During Engine Over Run

NOTE: The A.I.R. System is not completely noiseless. Under normal conditions noise rises in pitch as engine speed increases. To determine if excessive noise is the fault of the Air Injection Reactor System, operate the engine with the pump drive belt removed. If excessive noise does not exist with the belt removed proceed as follows:

- Check for a seized Air Injection Pump.
- Check hoses, tubes, air manifolds and all connections for leaks and proper routing.
- Check air injection pump for proper mounting.
- If none of the above conditions exist and the air injection pump has excessive noise remove and replace pump unit.

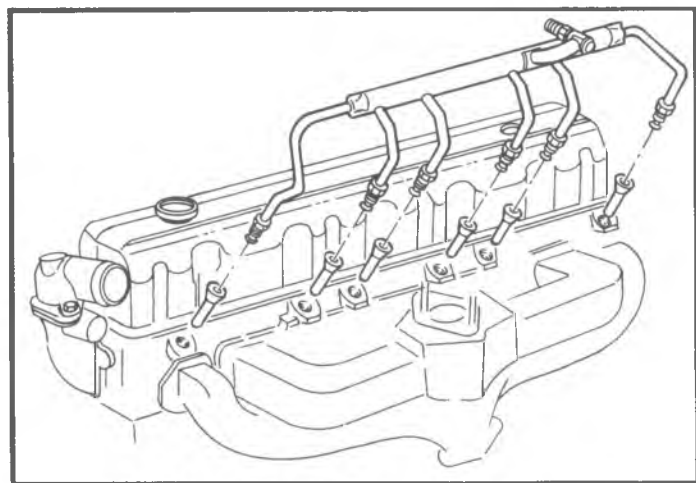

Fig. 24f—Air Injection Tubes (In-Line Engine)

**Replacement**

- Disconnect the hoses at the pump.
- Remove pump pulley as outlined.
- Remove pump mounting bolts and remove pump.
- Install pump with mounting bolts loose.
- Install pump pulley as outlined.
- Install and adjust belt as outlined.

- Connect the hoses at the pump.
- Tighten mounting bolts securely.

**Pressure Relief Valve**

NOTE: The pressure relief valve is incorporated in the diverter valve. The complete unit must be replaced to correct a malfunction of the relief valve.

**DIAGNOSIS**

While the A.I.R. system will result in exhaust emissions below the requirements when it is properly installed and maintained, it will not provide the desired reduction in exhaust emissions if some of the engine components malfunction.

Because of the relationship between "Engine Tune Up" and "Unburned Exhaust Gases", the condition of Engine Tune Up should be checked whenever the Air Injection Reactor System seems to be malfunctioning. Particular care should be taken in checking items that affect the fuel-air ratio such as the crankcase ventilation system, the carburetor and the carburetor air cleaner.

If all other components seem to be operating

satisfactorily, visually inspect A.I.R. system for loose drive belts, loose or deteriorated hoses and missing or broken components.

If after completion of tune-up and visual inspection, malfunction still exists, refer to the diagnosis chart for symptoms, probable cause, and remedy.

NOTE: The A.I.R. system is not completely noiseless. Under normal conditions, noise rises in pitch as engine speed increases. To determine if excessive noise is the fault of the air injection system, disconnect the drive belt and operate the engine. If noise now does not exist, proceed with diagnosis.

6T-34 EMISSION CONTROL SYSTEMS

CONDITION	POSSIBLE CAUSE	CORRECTION
No air supply — accelerate engine to 1500 rpm and observe air flow from hoses. If the flow increases as the rpm's increase, the pump is functioning normally. If not, check possible cause.	<ol style="list-style-type: none"> <li>Loose drive belt</li> <li>Leaks in supply hose</li> <li>Leak at fitting(s)</li> <li>Diverter valve leaking</li> <li>Diverter valve inoperative</li> <li>Check valve inoperative</li> </ol>	<ol style="list-style-type: none"> <li>Tighten to specs.</li> <li>Locate leak and repair</li> <li>Tighten or replace clamps.</li> <li>If air is expelled through diverter muffler with vehicle at idle, replace diverter valve.</li> <li>Usually accompanied by backfire during deceleration. Replace diverter valve.</li> <li>Blow through hose toward air manifold, if air passes, function is normal. If air can be sucked from manifold, replace check valve.</li> </ol>
Excessive pump noise, chirping, rumbling, or knocking	<ol style="list-style-type: none"> <li>Leak in hose</li> <li>Loose hose</li> <li>Hose touching other engine parts</li> <li>Diverter valve inoperative</li> <li>Check valve inoperative</li> <li>Pump mounting fasteners loose</li> <li>Pump failure</li> </ol>	<ol style="list-style-type: none"> <li>Locate source of leak using soap solution and correct.</li> <li>Reassemble and replace or tighten hose clamp.</li> <li>Adjust hose position.</li> <li>Replace diverter valve.</li> <li>Replace check valve.</li> <li>Tighten mounting screws as specified.</li> <li>Replace pump.</li> </ol>
Excessive belt noise	<ol style="list-style-type: none"> <li>Loose belt</li> <li>Seized pump</li> </ol>	<ol style="list-style-type: none"> <li>Tighten to spec.</li> <li>Replace pump</li> </ol>
Excessive pump noise. Chirping	<ol style="list-style-type: none"> <li>Insufficient break-in</li> </ol>	<ol style="list-style-type: none"> <li>Run vehicle 10-15 miles at turnpike speeds—recheck.</li> </ol>
Centrifugal filter fan damaged or broken.	<ol style="list-style-type: none"> <li>Mechanical damage</li> </ol>	<ol style="list-style-type: none"> <li>Replace centrifugal filter fan.</li> </ol>
Exhaust tube bent or damaged.	<ol style="list-style-type: none"> <li>Mechanical damage</li> </ol>	<ol style="list-style-type: none"> <li>Replace exhaust tube.</li> </ol>
Poor idle or driveability.	<ol style="list-style-type: none"> <li>A defective A.I.R. pump cannot cause poor idle or driveability.</li> </ol>	<ol style="list-style-type: none"> <li>Do not replace A.I.R. pump.</li> </ol>

Fig. 25F—A.I.R. System Diagnosis Chart

## SECTION 6Y

# ENGINE ELECTRICAL

### CONTENTS OF THIS SECTION

Energizer/Battery .....	6Y-1	Ignition System .....	6Y-24
Charging System .....	6Y-16	Starting System .....	6Y-49
		Special Tools .....	6Y-60

## ENERGIZER/BATTERY

### INDEX

General Description .....	6Y-1	Carrier and Hold-Down .....	6Y-5
Theory of Operation .....	6Y-2	Cleaning .....	6Y-5
General Information .....	6Y-4	Energizer Rating .....	6Y-5
Common Causes of Failure .....	6Y-4	Selecting and Replacement Energizer .....	6Y-5
Care of Energizer .....	6Y-4	Safety Precautions .....	6Y-6
Energizer Storage .....	6Y-4	Charging Procedures .....	6Y-6
Electrolyte Freezing .....	6Y-4	Charging Guide .....	6Y-8
Electrolyte Level .....	6Y-5	Test Procedures .....	6Y-7
Water Usage .....	6Y-5	Installing Battery .....	6Y-9
		Diagnosis .....	6Y-14

## GENERAL DESCRIPTION

The energizer (fig. 1b) is made up of a number of separate elements, each located in an individual cell in a hard rubber case. Each element consists of an assembly of positive plates and negative plates containing dissimilar active materials and kept apart by separators.

The elements are immersed in an electrolyte composed of dilute sulfuric acid. Plate straps located on the top of each element connect all the positive plates and all the



Fig. 1b—Energizer

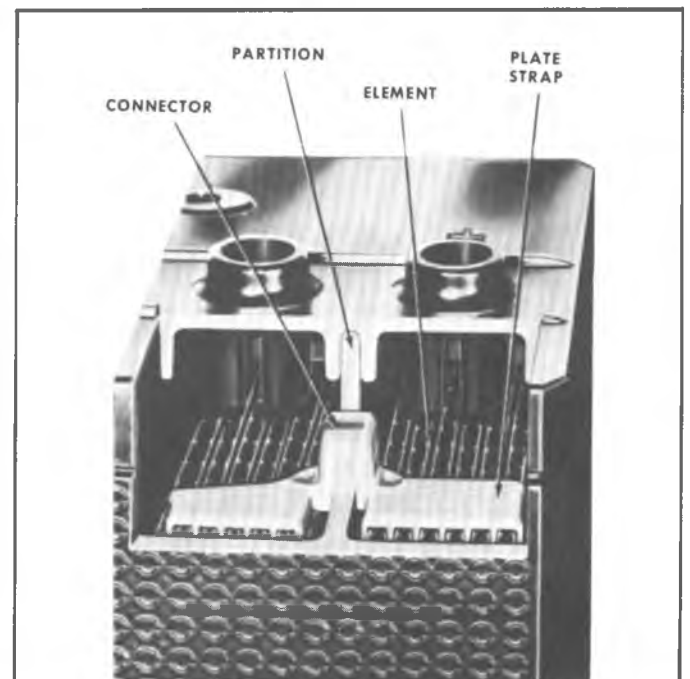

Fig. 2b—Internal View of Energizer

## 6Y-2 ENGINE ELECTRICAL

negative plates into groups. The elements are connected in series electrically by connectors that pass directly through the case partitions between cells. The energizer top is a one piece cover. The cell connectors, by passing through the cell partitions, connect the elements along the shortest practical path (fig. 2b). With the length of the electrical circuit inside the Energizer reduced to a minimum, the internal voltage drop is decreased resulting in improved performance, particularly during engine cranking at low temperatures.

The terminals of this type Energizer, passing through the side of the case, are positioned out of the "wet" area surrounding the vent wells. Normal spillage, spewing, condensation, and road splash are not as likely to reach or remain on the vertical sides where the terminals are located. This greatly decreases the cause of terminal corrosion. Also, construction of the terminals is such that the mating cable connector seals the junction and provides a permanently tight and clean connection. Power robbing resistance in the form of corrosion is thereby eliminated at these maintenance-free connections.

The hard, smooth, one piece cover greatly reduces the tendency for corrosion to form on the top of the Energizer. The cover is bonded to the case forming an air-tight seal between the cover and case.

Electrical energy is released by chemical reactions between the active materials in the two dissimilar plates and the electrolyte whenever the Energizer is being "discharged." Maximum electrical energy is released only when the cells are being discharged from a state of full charge.

As the cells discharge, chemical changes in the active materials in the plates gradually reduce the potential electrical energy available. "Recharging" the Energizer with a flow of direct current opposite to that during discharge reverses the chemical changes within the cells and restores them to their active condition and a state of full charge.

There are two types of Energizers, the "dry charge" type and the "wet charge" type. The difference in types depends on the method of manufacture. A "dry charge" Energizer contains fully charged elements which have

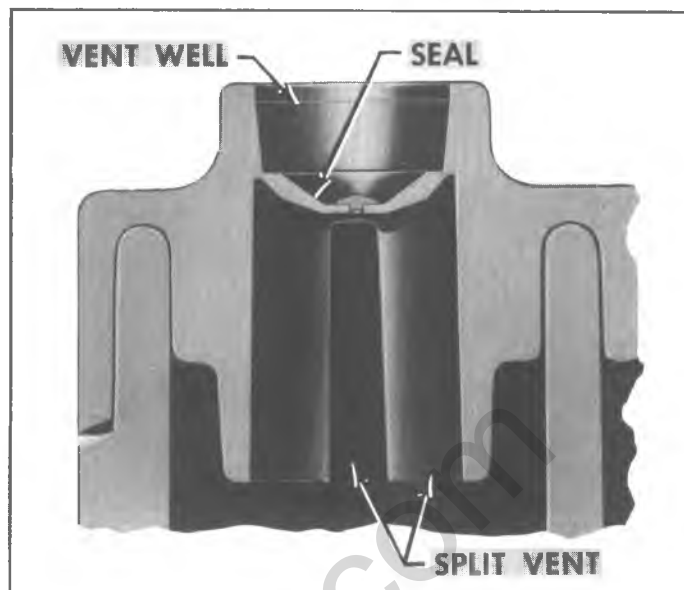

Fig. 3b—Typical Vent Well Construction W/Seal

been thoroughly washed and dried. This type of Energizer contains no electrolyte until it is activated for service in the field and, therefore, leaves the factory in a dry state. Consequently, it is called a "dry charge" Energizer.

Each vent well in a "dry charge" Energizer has a hard rubber seal to prevent the entrance of air and moisture which would oxidize the negative active materials and reduce the freshness of the Energizer (Fig. 3b). The hard rubber seals and the bonding between the case and one-piece cell cover make possible a vacuum sealed assembly which can be stored for very long periods of time without detrimental effects.

Before activating the "dry charge" Energizer, the hard rubber seals are broken simply by pushing them down into each vent well. The seals drop into the cells, and can remain there since they are not chemically active and will cause no harm.

A wet charged Energizer contains fully charged elements which are filled with electrolyte before being shipped from the factory.

## THEORY OF OPERATION

The lead-acid Energizer or storage battery (Fig. 1b) is an electrochemical device for converting chemical energy into electrical energy. It is not a storage tank for electricity as is often believed, but instead, stores electrical energy in chemical form.

Active materials within the battery react chemically to produce a flow of direct current whenever lights, radio, cranking motor, or other current consuming devices are connected to the battery terminal posts. This current is produced by chemical reaction between the active

materials of the PLATES and the sulfuric acid of the ELECTROLYTE.

The battery performs three functions in automotive applications:

1. It supplies electrical energy for the cranking motor and for the ignition system as the engine is started.
2. It supplies current for the lights, radio, heater, and other accessories when the electrical demands of these devices exceed the output of the generator.
3. The battery acts as a voltage stabilizer in the

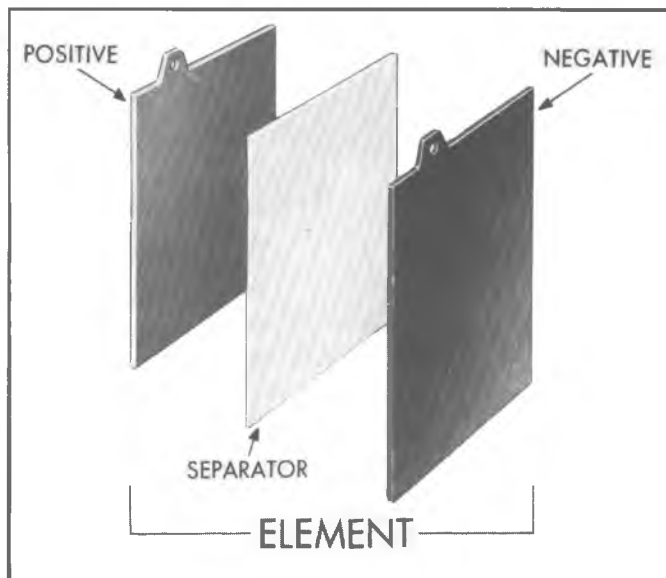

Fig. 4b—Battery Element (Simple)

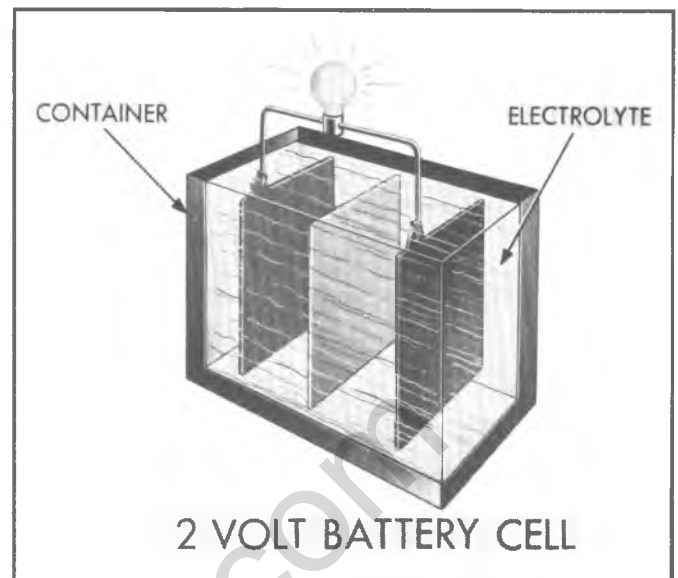

Fig. 5b—Two Volt Battery Cell

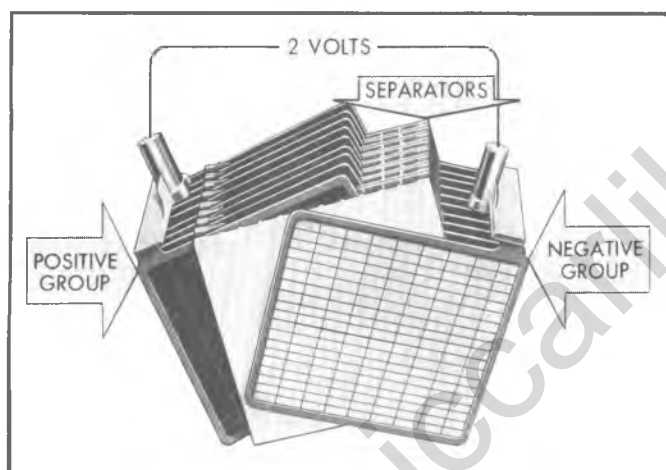

Fig. 6b—Battery Element (Compound)

electrical system. Satisfactory operation of the vehicle is impossible unless the battery performs each of these functions.

The simplest unit of a lead-acid storage battery is made up of two unlike materials, a positive plate and a negative plate, kept apart by a porous separator. This assembly is called an "ELEMENT" (Fig. 4b).

When this simple element is put in a container filled with a sulphuric acid and water solution called "electrolyte", a two-volt "cell" is formed. Electricity will flow when the plates are connected to an electrical load (Fig. 5b).

An element made by grouping several positive plates together and several negative plates together with separators between them also generates two-volts but can produce more total electrical energy than a simple cell (Fig. 6b).

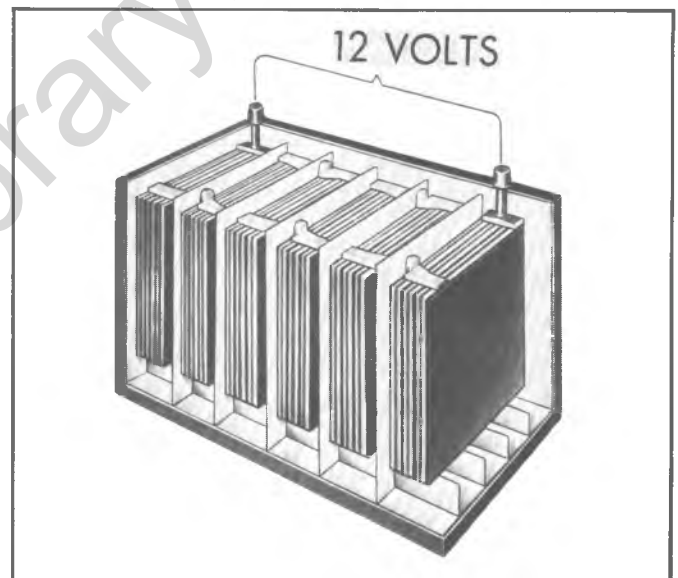

Fig. 7b—Typical 12 Volt Battery Cell Arrangement

When six cells are connected in series, a "battery" of cells is formed which produces six times as much electrical pressure as a simple cell, or a total of 12 volts (Fig. 7b).

If the battery continuously supplies current, it becomes run-down or discharged. This is where the generator gets into the act. The generator restores the chemical energy to the battery. This is done by sending current through the battery in a direction opposite to that during discharge. The generator current reverses the chemical actions in the battery and restores it to a charged condition.

## GENERAL INFORMATION

### COMMON CAUSES OF FAILURE

Since the Energizer is a perishable item which requires periodic servicing, a good maintenance program will insure the longest possible Battery life. If the Energizer tests good but fails to perform satisfactorily in service for no apparent reason, the following are some of the more important factors that may point to the cause of the trouble.

1. Vehicle accessories inadvertently left on overnight to cause a discharge condition.
2. Slow speed driving of short duration, to cause an undercharged condition.
3. A vehicle electrical load exceeding the generator capacity.
4. Defect in the charging system such as high resistance, slipping fan belt, faulty generator or voltage regulator.
5. Battery abuse, including failure to keep the Battery top clean, cable attaching bolts clean and tight, and improper addition of water to the cells.

### CARE OF ENERGIZER

#### Energizer Storage

Since the "dry charge" Energizer is vacuum sealed against the entrance of moisture, it may be stored for very long periods of time without detrimental effects so long as the seals remain unbroken. When storing a "dry charge" Energizer, the following procedures should be followed:

1. Keep the Energizer in its shipping carton until activated.
2. Do not stack the "dry charge" Energizer in cartons more than four high.
3. Rotate stocks regularly.
4. Maintain the storage area at 60°F or higher to aid activation.

A wet charged Energizer will not maintain its charged condition during storage, and must be recharged periodically. During storage, even though the Energizer is not in use, a slow reaction takes place between the chemicals inside the Energizer which causes the Energizer to lose charge and "wear out" slowly. This reaction is called "self-discharge." The rate at which self-discharge occurs varies directly with temperature of the electrolyte.

Note from Figure 8b that an Energizer stored in an area at 100°F for 60 days has a much lower specific gravity and consequently a lower state of charge than one stored in an area at 60°F for the same length of time.

To minimize self-discharge, a wet Energizer should be

stored in as cool a place as possible, provided the electrolyte does not freeze.

A wet Energizer which has been allowed to stand idle for a long period of time without recharging may become so badly damaged by the growth of lead sulfate crystals (sulfation) in the plates that it can never be restored to a normal charged condition. An Energizer in this condition not only loses its capacity but also is subject to changes in its charging characteristics. These changes, due to self-discharge, are often serious enough to prevent satisfactory performance in a vehicle.

Periodic recharging, therefore, is necessary to maintain a wet charged Energizer in a satisfactory condition while in storage. See paragraph "Charging Wet Energizer in Storage."

#### Charging Wet Energizer in Storage

Before placing an Energizer on charge, always check the electrolyte level and add water, as necessary, to bring the electrolyte up to the bottom of the split vent.

The Energizer should be brought to a fully charged condition every 30 days by charging as covered under heading of "Energizer Charging."

Trickle charging should not be used to maintain an Energizer in a charged condition when in storage. The low charge rate method applied every 30 days is the best method of maintaining a wet charged Energizer in a fully charged condition without damage.

#### Electrolyte Freezing

The freezing point of electrolyte depends on its specific

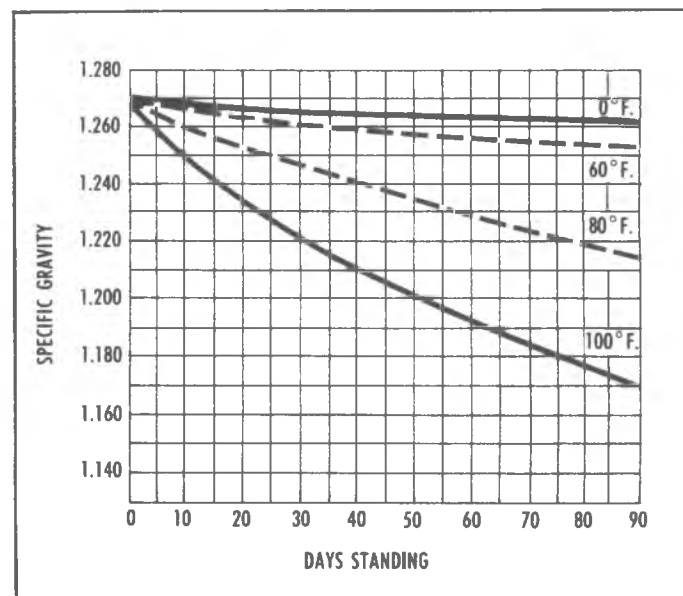

Fig. 8b— Rate of Self-Discharge



gravity. The following table gives the freezing temperatures of electrolyte at various specific gravities.

Since freezing may ruin a wet Energizer, it should be protected against freezing by keeping it in a charged condition. This is true whether the wet Energizer is in storage or in service. Antifreeze should never be added to the Energizer to prevent it from freezing as this practice is very harmful.

### Electrolyte Level

To check the electrolyte level, remove the vent plug and visually observe the electrolyte level in the vent well. The bottom of the vent well features a split vent which will cause the surface of the electrolyte to appear distorted when it makes contact. The electrolyte level is correct when the distortion first appears at the bottom of the split vent (fig. 9b).

Value of Specific Gravity Corrected to 80°F.	Freezing Temp. Deg. F.	Value of Specific Gravity Corrected to 80°F.	Freezing Temp. Deg. F.
1.100	18	1.220	-13
1.120	13	1.240	-50
1.140	8	1.260	-75
1.160	1	1.280	-92
1.180	-6	1.300	-95
1.200	-17		

The electrolyte level in the Energizer should be checked regularly. In hot weather, particularly during trip driving, checking should be more frequent because of more rapid loss of water. If the electrolyte level is found to be low, then colorless, odorless, drinking water should be added to each cell until the liquid level rises to the split vent located in the bottom of the vent well. **DO NOT OVERFILL** because this will cause loss of electrolyte resulting in poor performance, short life, and excessive corrosion.

**CAUTION:** During service only water should be added to the Battery, not electrolyte.

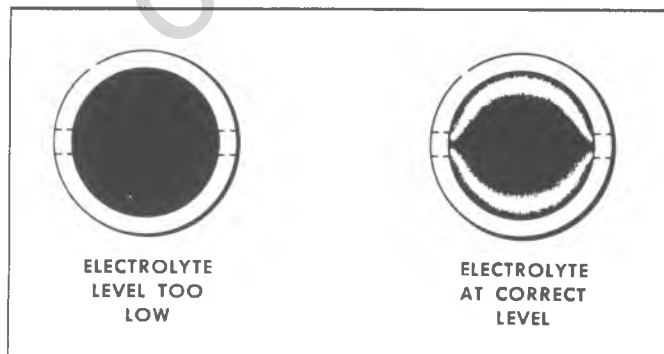

Fig. 9b—View Inside Vent Well

The liquid level in the cells should never be allowed to drop below the top of the plates, as the portion of the plates exposed to air may be permanently damaged with a resulting loss in performance.

### Water Usage

Excessive usage of water indicates the Battery is being overcharged. The most common causes of overcharge are high Battery operating temperatures, too high a voltage regulator setting, poor regulator ground wire connection. Normal Battery water usage is approximately one to two ounces per month per battery.

### Carrier and Hold-Down

The Energizer carrier and hold-down should be clean and free from corrosion before installing the Battery. The carrier should be in sound mechanical condition so that it will support the Battery securely and keep it level.

To prevent the Battery from shaking in its carrier, the hold-down bolts should be tight (60-80 in. lbs.). However, the bolts should not be tightened to the point where the Battery case or cover will be placed under a severe strain.

### Cleaning

The external condition of the Energizer should be checked periodically for damage such as cracked cover, case and vent plugs or for the presence of dirt and corrosion. The Energizer should be kept clean. An accumulation of acid film and dirt may permit current to flow between the terminals, which will slowly discharge the Battery. For best results when cleaning Energizers, wash first with a diluted ammonia or a soda solution to neutralize any acid present; then flush with clean water. Care must be taken to keep vent plugs tight, so that the neutralizing solution does not enter the cells.

### ENERGIZER RATING

battery generally has two classifications of ratings: (1) a 20 hour rating at 80 F and, (2) a cold rating at 0 F which indicates the cranking load capacity. The Ampere/Hour rating found on batteries was based on the 20 hour rating. That is, a battery capable of furnishing three (3) amperes for 20 hours while maintaining a specified average individual cell voltage would be classified as a 60 ampere hour battery (e.g. 3 amperes  $\times$  20 hours = 60 A.H.) a PWR (Peak Watt Rating) has been developed as a measure of the Energizer's cold cranking ability. The numerical rating is embossed on each case at the base of the Energizer. This value is determined by multiplying the max. current by the max. voltage. The PWR should not be confused with the ampere hour rating since two batteries with the same ampere hour rating can have quite different watt ratings. For battery replacement, a unit of at least equal power rating must be selected.

### SELECTING A REPLACEMENT ENERGIZER

Long and troublefree service can be more assured when the capacity or wattage rating of the replacement

## 6Y-6 ENGINE ELECTRICAL

Energizer is at least equal to the wattage rating of the Energizer originally engineered for the application by the manufacturer.

The use of an undersize Energizer may result in poor performance and early failure. Figure 10b shows how Energizer power shrinks while the need for engine cranking power increases with falling temperatures. Sub-zero temperatures reduce capacity of a fully charged Energizer to 45% of its normal power and at the same time increase cranking load to 3-1/2 times the normal warm weather load.

Hot weather can also place excessive electrical loads on the Energizer. Difficulty in starting may occur when cranking is attempted shortly after a hot engine has been turned off or stalls. In fact, modern high compression engines can be as difficult to start under such conditions as on the coldest winter day. Consequently, good performance can be obtained only if the Energizer has ample capacity to cope with these conditions.

An Energizer of greater capacity should be considered if the electrical load has been increased through the addition of accessories or if driving conditions are such that the generator cannot keep the Energizer in a charged condition.

On applications where heavy electrical loads are encountered, a higher output generator that will supply a charge during low speed operation may be required to increase Energizer life and improve Energizer performance.

## SAFETY PRECAUTIONS

When Energizers are being charged, an explosive gas mixture forms in each cell. Part of this gas escapes through the holes in the vent plugs and may form an explosive atmosphere around the energizer itself if ventilation is poor. This explosive gas may remain in or around the energizer for several hours after it has been charged. Sparks or flames can ignite this gas causing an

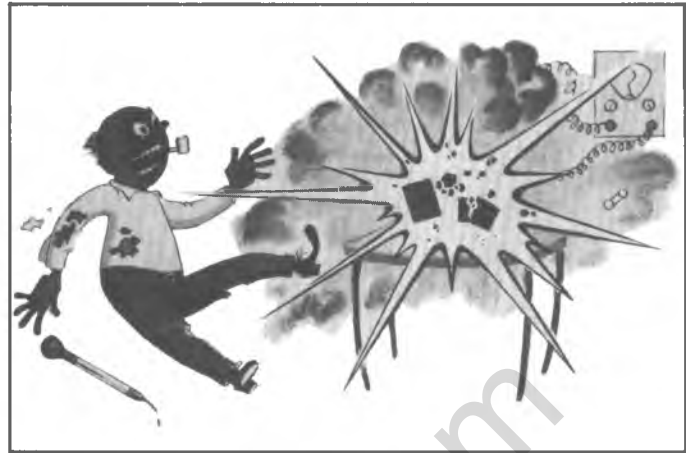

Fig. 11b—Sparks or Flames

internal explosion which may shatter the energizer (Fig. 11b).

The following precautions should be observed to prevent an explosion:

1. Do not smoke near energizers being charged or which have been very recently charged.
2. Do not break live circuits at the terminals of energizers because a spark usually occurs at the point where a live circuit is broken. Care must always be taken when connecting or disconnecting booster leads or cable clamps on fast chargers. Poor connections are a common cause of electrical arcs which cause explosions.

## CHARGING PROCEDURES

Before charging an energizer the electrolyte level must be checked and adjusted if needed. Energizer charging consists of applying a charge rate in amperes for a period of time in hours. Thus, a 10-ampere charge rate for seven hours would be a 70 ampere-hour (A.H.) charging input to the battery. Charging rates in the three to 50 ampere range are generally satisfactory. No particular charge rate or time can be specified for an energizer due to the following factors:

1. The size, or electrical capacity in ampere-hours (A.H.), of the Energizer.  
**EXAMPLE:** A completely discharged 70 A.H. energizer requires almost twice the recharging as a 40 A.H. energizer.
2. Temperature of the energizer electrolyte.  
**EXAMPLE:** About two hours longer will be needed to charge a 0°F. energizer than a 80°F. energizer.
3. Energizer state-of-charge at the start of the charging period.

**EXAMPLE:** A completely discharged energizer requires twice as much charge in ampere-hours as a one-half charged energizer.

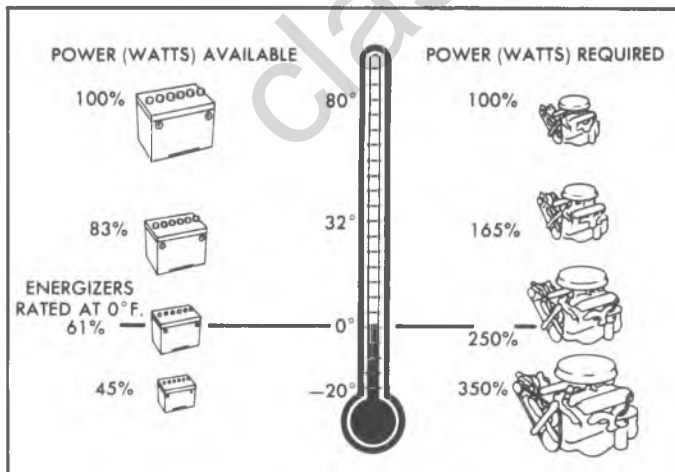

Fig. 10b—Energizer Power vs Falling Temperature

Energizer age and condition.

**EXAMPLE:** An energizer that has been subjected to severe service will require up to 50% more ampere-hour charging input than a relatively new energizer.

The following basic rule applies to any energizer charging situation:

“Any energizer may be charged at any rate in amperes for as long as spewing of electrolyte due to violent gassing does not occur, and for as long as electrolyte temperature does not exceed 125°F. If spewing of electrolyte occurs, or if electrolyte temperature exceeds 120°F., the charging rate in amperes must be reduced or temporarily halted to avoid damage to the Energizer.

The energizer is fully charged when over a two-hour period at a low charging rate in amperes all cells are gassing freely (not spewing liquid electrolyte), and no change in specific gravity occurs. The full charge specific gravity is 1.260-1.280, corrected for electrolyte temperature with the electrolyte level at the split ring, unless electrolyte loss has occurred due to age or overfilling in which case the specific gravity reading will be lower. For the most satisfactory charging, the lower charging rates in amperes are recommended.

If after prolonged charging a specific gravity of at least 1.230 on all cells cannot be reached, the battery is not in an optimum condition and will not provide optimum performance; however, it may continue to provide additional service if it has performed satisfactorily in the past.

An “emergency boost charge”, consisting of a high charging rate for a short period of time, may be applied as a temporary expedient in order to crank an engine.

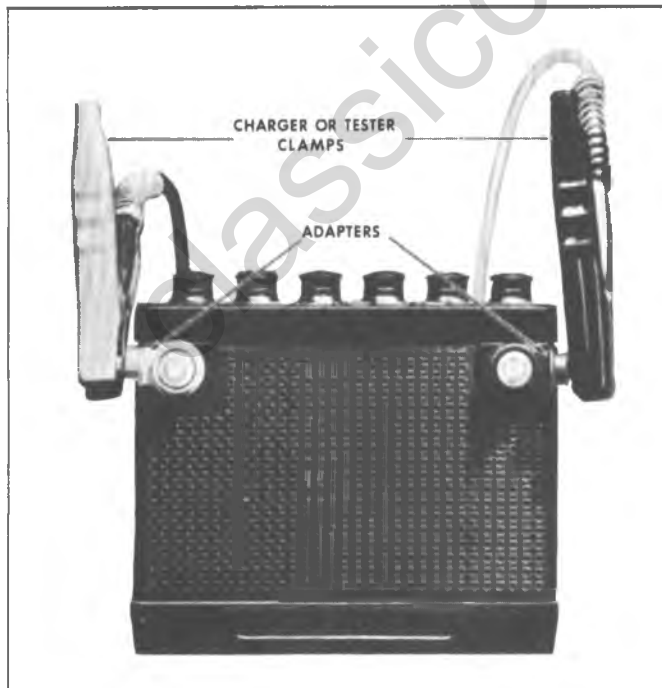

Fig. 12b—Charging Lead Adapters

However, this procedure usually supplies insufficient energizer reserve to crank a second and third time. Therefore, the “emergency boost charge” must be followed by a subsequent charging period of sufficient duration to restore the battery to a satisfactory state of charge. Refer to the charging guide in this section.

When out of the vehicle, the sealed side terminal battery will require adapters (Fig. 12b) for the terminals to provide a place for attachment of the charging leads. Adapters are available through local parts service.

When the side terminal battery is in the vehicle, the studs provided in the wiring harness are suitable for attachment of the charger’s leads.

**CAUTION:** *Exercise care when attaching charger leads to side terminal studs to avoid contact with vehicle metal components which would result in damage to the energizer.*

## TESTING PROCEDURES

Testing procedures are used to determine whether the battery is (1) good and usable, (2) requires recharging or (3) should be replaced. Analysis of battery conditions can be accomplished by performing a visual inspection, instrument test and the full charge hydrometer test. Refer to test procedure chart in this section.

### Visual Inspection

The first step in testing the battery should be a visual inspection, which very often will save time and expense in determining battery condition.

- Check the outside of the battery for a broken or cracked case or a broken or cracked cover. If any damage is evident, the battery should be replaced.
- Note the electrolyte level. Levels that are too low or too high may cause poor performance, as covered in the section entitled “General Information”.
- Check for loose cable connections. Correct as required before proceeding with tests.

### Instrument Test

A number of suppliers have approved testing equipment available. These testers have a programmed test procedure consisting of a series of timed discharge and charge events, requiring approximately 2 to 3 minutes, that will determine the condition of the battery with a high degree of accuracy. When using these testers, the procedure recommended by the tester manufacturer should be followed. Batteries should not be charged prior to testing as doing so may alter the test results. If a tester is not available for testing, the “Specific Gravity Cell Comparison Test” may be used or an alternate method, but with a sacrifice in testing accuracy.

## CHARGING GUIDE

### RECOMMENDED RATE\* AND TIME FOR FULLY DISCHARGED CONDITION

**CAUTION: EXERCISE CARE WHEN ATTACHING CHARGER LEADS TO SIDE TERMINAL STUDS TO AVOID CONTACT WITH VEHICLE METAL COMPONENTS WHICH COULD RESULT IN DAMAGE TO THE ENERGIZER.**

Watt Rating	5 Amperes	10 Amperes	20 Amperes	30 Amperes	40 Amperes	50 Amperes
Below 2450	10 Hours	5 Hours	2-1/2 Hours	2 Hours		
2450-2950	12 Hours	6 Hours	3 Hours	2 Hours	1-1/2 Hours	
Above 2950	15 Hours	7-1/2 Hours	3-1/4 Hours	2 Hours	1-3/4 Hours	1-1/2 Hours

\*Initial rate for constant voltage taper rate charger.

To avoid damage, charging rate must be reduced or temporarily halted if:

1. Electrolyte temperature exceeds 125°F.
2. Violent gassing or spewing of electrolyte occurs.

Battery is fully charged when over a two hour period at a low charging rate in amperes all cells are gassing freely and no change in specific gravity occurs. For the most satisfactory charging, the lower charging rates in amperes are recommended.

Full charge specific gravity is 1.260-1.280 corrected for temperature with electrolyte level at split ring.

NOTE: New energizers which have become completely discharged over a relatively long period of time, such as during vehicle storage, should be tested by the hydrometer method. Energizers discharged to this degree cannot be accurately tested using equipment requiring load capability comparison tests.

NOTE: Equipment to perform this test may be procured from local suppliers of testing equipment.

To begin, charge the battery, if necessary, until all cells are at least 1.200 specific gravity.

1. If unable to obtain specific gravity 1.200 @ 80°F. in all cells, replace battery.
2. If able to obtain a specific gravity of 1.200 or more @ 80°F. in all cells, remove the vent caps and connect a 300 amp. load for 15 seconds.
  - a. If smoke occurs in one or more cells, replace the battery.
  - b. If smoke does not occur proceed to step 3.
3. Place a thermometer in one cell and apply a specified load from chart No. 1. Read the voltage at 15 seconds with load connected, then remove load and read electrolyte temperature. Compare temperature and voltage readings with chart No. 2.
  - a. If reading is less than voltage on chart No. 2, replace battery.
  - b. If reading is same as or greater than voltage on chart No. 2, fully charge, clean and return battery to service.

### Full Charge Hydrometer Test

This test should be used only on Energizers which test good with testing equipment or "Specific Gravity Cell Comparison Test" but which subsequently fail in service.

- Remove the Energizer from the vehicle, and adjust the electrolyte level as necessary, by adding colorless, odorless, drinking water.
- Fully charge the Energizer at the Slow Charging rate as covered in the section entitled "Charging Procedures".
- Measure the specific gravity of the electrolyte in each cell and interpret as follows:

Hydrometer Reading Less Than 1.230—Full charge hydrometer readings less than 1.230 corrected for temperature indicate the Battery is defective and should be replaced.

Hydrometer Readings Above 1.310—Full charge hydrometer readings above 1.310 corrected for temperature indicate that the cells have been improperly filled (activation) or improperly serviced. Poor service and short Battery life will result.

### Load Test

In addition to the instrument test and full charge hydrometer test, the following load test may also be performed to check the condition of the battery.

**CHART NO. 1 ENERGIZER LOAD TEST VALUES**

MODEL NO.	AMP LOAD
Y86	130
R88	180
R88W	230

CHART NO. 2 VOLTAGE AND TEMPERATURE CHART

Electrolyte Temperature	Minimum Voltages*
Down to 80°	9.6
70°	9.6
60°	9.5
50°	9.4
40°	9.3
30°	9.1
20°	8.9
10°	8.7
0	8.5

\*Voltage must not drop below minimum listed at given temperature when battery is subjected to the proper load for 15 seconds and is 1.200 specific gravity @ 80° F. or more.

### Specific Gravity Readings (Fig. 13b)

A hydrometer can be used to measure the specific gravity of the electrolyte in each cell.

The hydrometer measures the percentage of sulphuric acid in the battery electrolyte in terms of specific gravity. As a battery drops from a charged to a discharged condition, the acid leaves the solution and enters the plates, causing a decrease in specific gravity of electrolyte. An indication of the concentration of the electrolyte is obtained with a hydrometer.

When using a hydrometer, observe the following points:

1. Hydrometer must be clean, inside and out, to insure an accurate reading.
2. Hydrometer readings must never be taken immediately after water has been added. The water must be thoroughly mixed with the electrolyte by charging for at least 15 minutes at a rate high enough to cause vigorous gassing.
3. If hydrometer has built-in thermometer, draw liquid into it several times to insure correct temperature before taking reading.
4. Hold hydrometer vertically and draw in just enough liquid from battery cell so that float is free floating. Hold hydrometer at eye level so that float is vertical and free of outer tube, then take reading at surface of liquid. Disregard the curvature where the liquid rises against float stem due to surface tension.
5. Avoid dropping battery fluid on car or clothing as it is extremely corrosive. Any fluid that drops should be washed off immediately with baking soda solution.

The specific gravity of the electrolyte varies not only with the percentage of acid in the liquid but also with temperature. As temperature increases, the electrolyte expands so that the specific gravity is reduced. As temperature drops, the electrolyte contracts so that the specific gravity increases. Unless these variations in specific gravity are taken into account, the specific gravity obtained by the hydrometer may not give a true indication of the concentration of acid in the electrolyte.

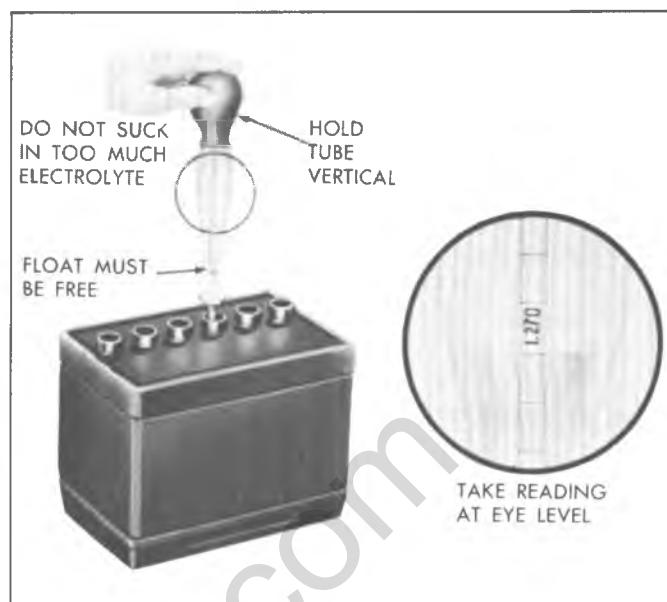

Fig. 13b—Checking Specific Gravity

A fully charged Battery will have a specific gravity reading of approximately 1.270 at an electrolyte temperature of 80°F. If the electrolyte temperature is above or below 80°F, additions or subtractions must be made in order to obtain a hydrometer reading corrected to the 80°F standard. For every 10° above 80°F, add four specific gravity points (.004) to the hydrometer reading. Example: A hydrometer reading of 1.260 at 110°F would be 1.272 corrected to 80°F, indicating a fully charged Battery. For every 10° below 80°F, subtract four points (.004) from the reading. Example: A hydrometer reading of 1.272 at 0°F would be 1.240 corrected to 80°F, indicating a partially charged Battery.

### Specific Gravity Cell Comparison Test

This test may be used when an instrument tester is not available. To perform this test measure the specific gravity of each cell, regardless of state of charge, and interpret the results as follows:

- If specific gravity readings show a difference between the highest and lowest cell of .050 (50 points) or more, the Battery is defective and should be replaced.

### INSTALLING BATTERIES

To install a Battery properly, it is important to observe the following precautions:

- Connect grounded terminal of Battery last to avoid short circuits which may damage the electrical system.
- Do not connect primary lead until secondary negative cable wire has been grounded to sheet metal.
- Be sure there are no foreign objects in the carrier, so that the new Battery will rest properly in the bottom of the carrier.

## 6Y-10 ENGINE ELECTRICAL

- Tighten the hold-down evenly until snug (60-80 in. lbs.). Do not draw down tight enough to distort or crack the case or cover.
- Be sure the cables are in good condition and the terminal bolts are clean and tight. Make sure the ground cable is clean and tight at engine block or frame.
- Check polarity to be sure the Battery is not reversed with respect to the charging system.

Do not over torque cable terminal studs.

### REPLACEMENT (Fig. 14b, 15b and 16b)

1. Disconnect battery negative cable and then the positive cable.

2. Disconnect battery vent covers from vent plugs if so equipped.
3. Remove battery hold-down clamp bolt and clamp.
4. Remove battery from tray and transfer vent cover to replacement battery, if so equipped.
5. Position new battery, which has been properly activated, in the battery tray.

6. Install battery hold down clamp and bolt.

NOTE: Recommended hold-down bolt torque is 70 in. lbs.

7. Connect battery vent covers to vent plugs, if so equipped.
8. Install battery positive and negative cables and tighten terminal bolts to 70 in. lbs. torque.

Classiccarlibrary.com

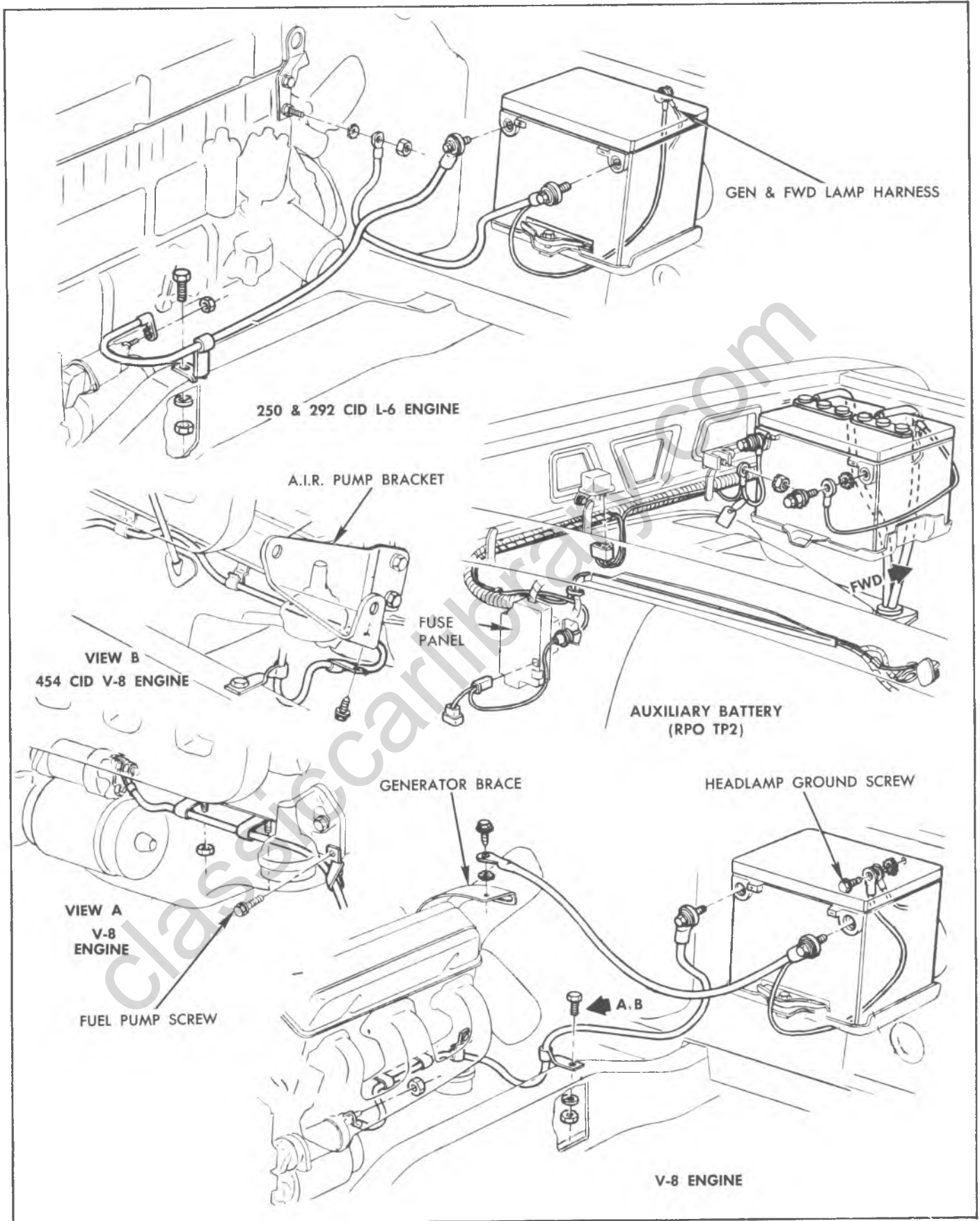

Fig. 14b—Battery Installation (C-K Series)

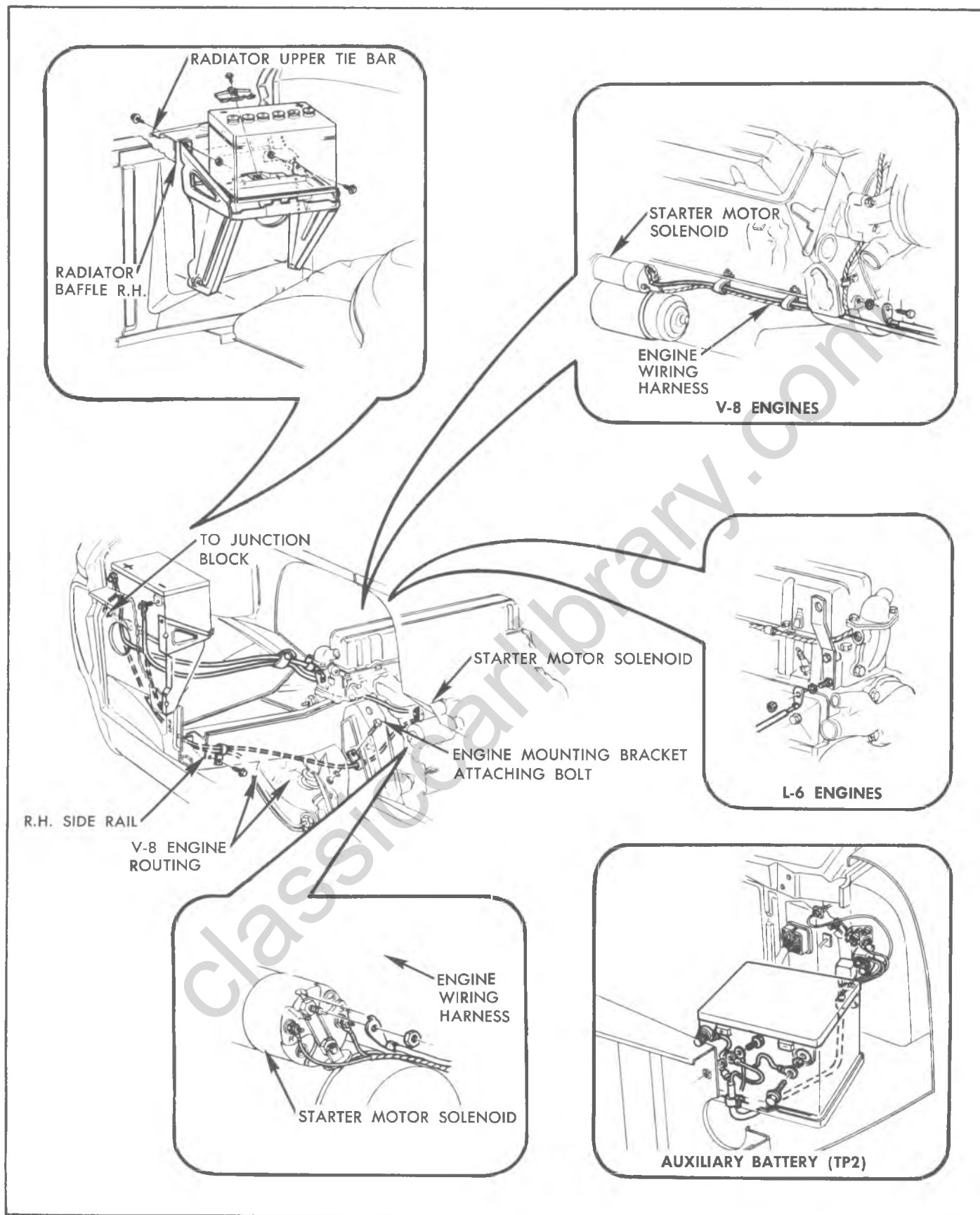

Fig. 15b—Battery Installation (G-Series)



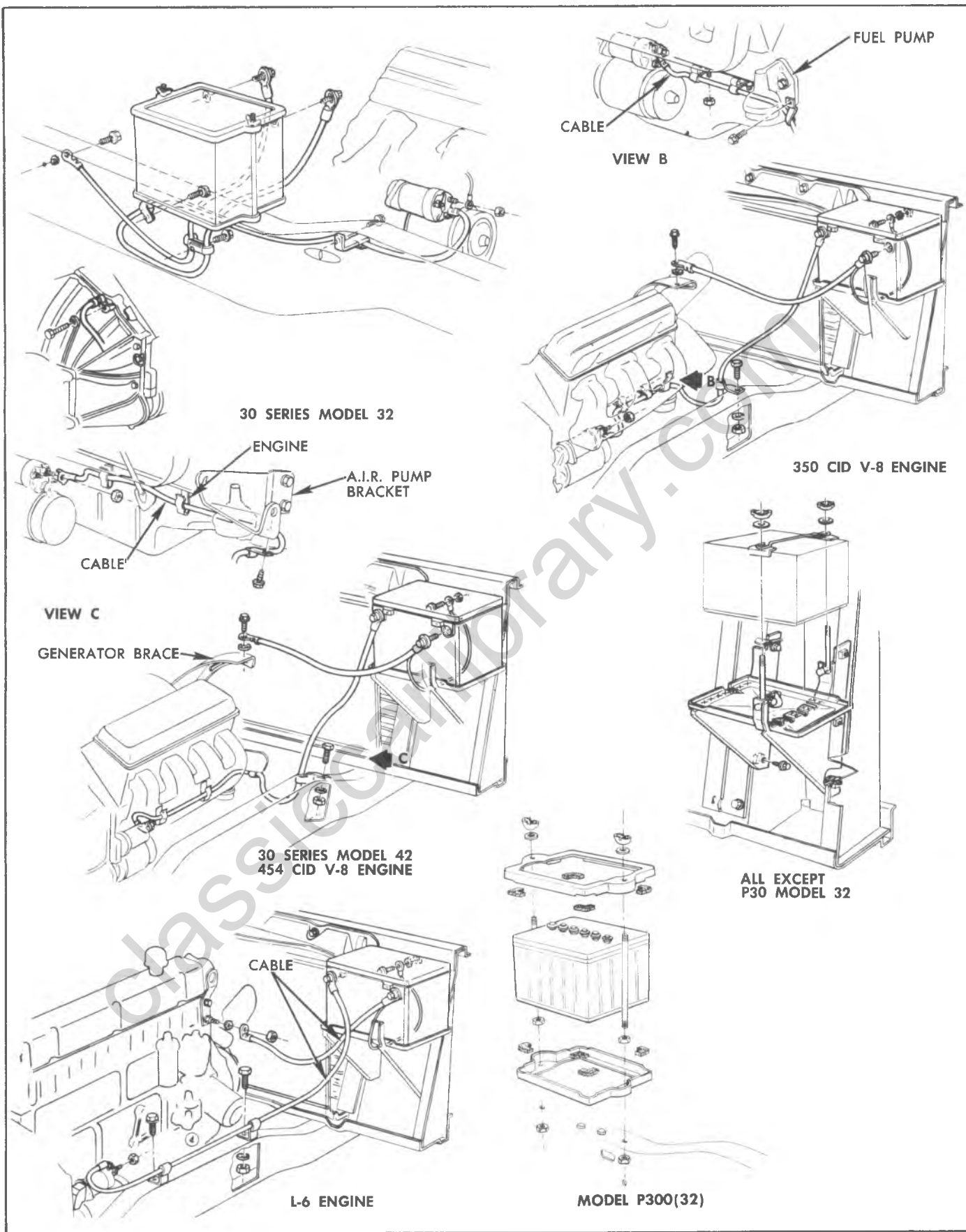

Fig. 16b—Battery Installation (P Series)

## ENERGIZER/BATTERY TEST PROCEDURE

To determine the ability of an Energizer or battery to function properly requires testing. The accuracy of the testing changes with temperature, specific gravity, age of the battery, etc. Therefore, an accurate test has more than one step:

Step 1. Visual Inspection.

Step 2. Specific gravity check (hydrometer).

Step 3. Programmed Instrument Test.

Step 4. Load Test.

**CAUTION:** *Wear safety glasses. Do not break live circuits at energizer/battery terminals. When testing be certain to remove gases at Energizer/battery cover caused by charging.*

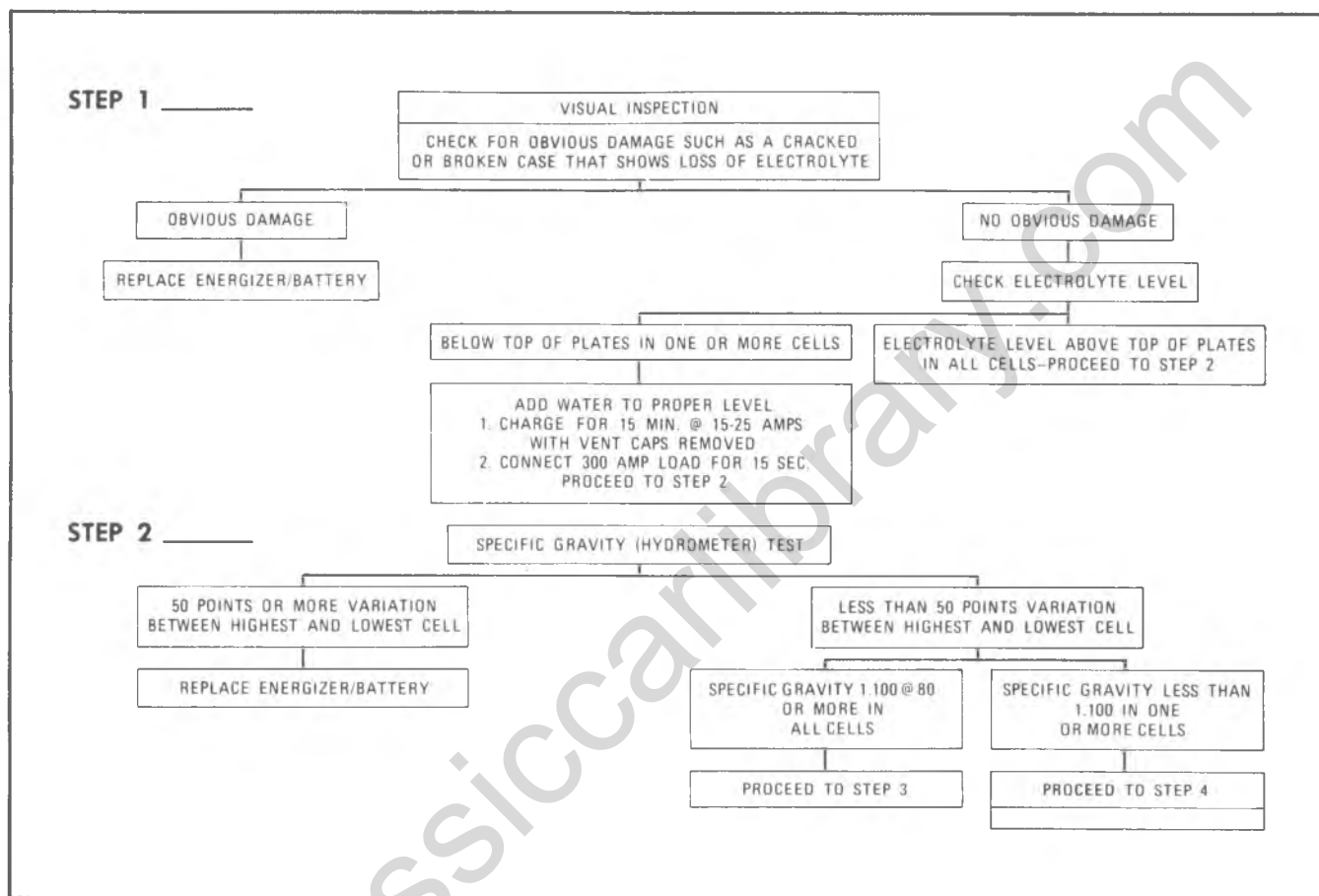

STEP 3 \_\_\_\_\_

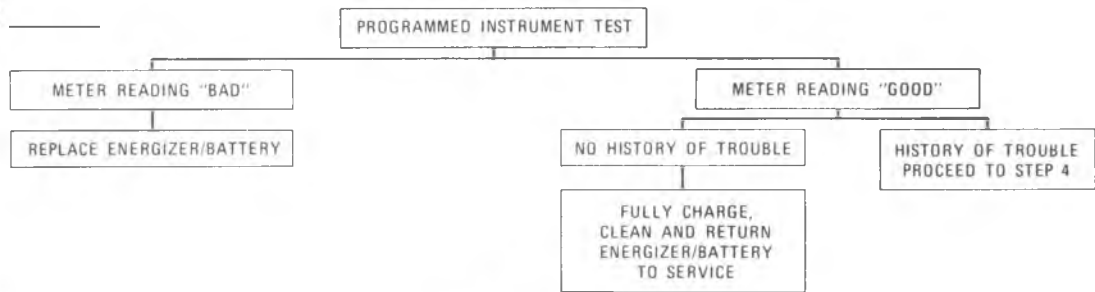

STEP 4 \_\_\_\_\_

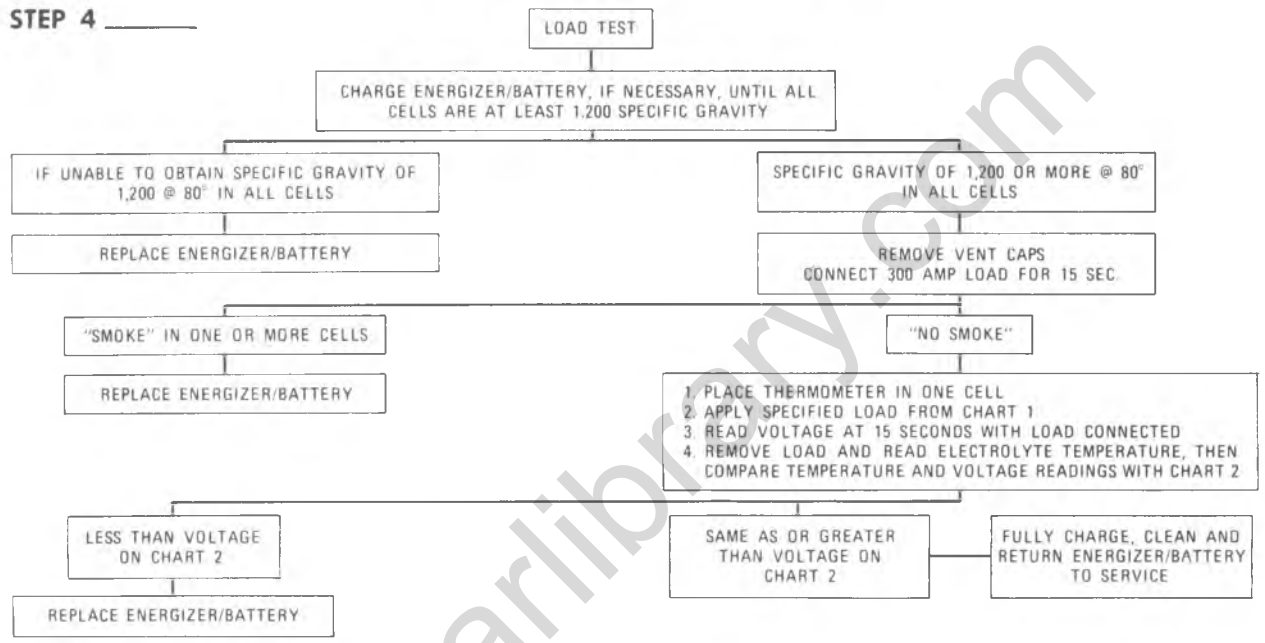

Classiccarlibrary.com

# THE CHARGING SYSTEM

## 10-SI SERIES DELCOTRON SYSTEM

### INDEX

General Description .....	6Y-16	Static Checks .....	6Y-20
Theory of Operation .....	6Y-16	Indicator Lamp Circuit Check .....	6Y-20
Service Operations .....	6Y-18	Undercharged Energizer Condition .....	6Y-21
Delcotron Replacement .....	6Y-18	Overcharged Energizer Condition .....	6Y-22
Pulley Replacement .....	6Y-18	Generator Output Test .....	6Y-22
Diagnosis .....	6Y-20	Other Harness Checks .....	6Y-23

### GENERAL DESCRIPTION

The 10-SI series Delcotron generator shown in Figure 1C is typical of a variety of models. A solid state regulator having an integrated circuit is built into the end frame. Although models are available with different outputs at idle and different maximum outputs, their basic operating principles are the same.

The Delcotron generator consists primarily of two end frame assemblies, a rotor assembly and a stator assembly. A typical cross-sectional view is shown in Figure 1C. The rotor assembly is supported in the drive end frame by a ball bearing and in the slip ring end frame by a roller bearing. These rotor bearings contain a supply of lubricant sufficiently adequate to eliminate the need for periodic lubrication. Two brushes carry current

through the two slip rings to the field coil mounted on the rotor and under normal conditions will provide long periods of attention - free service. No periodic adjustments or maintenance are required on the generator assembly.

The stator windings are assembled on the inside of a laminated core that forms part of the generator frame. A rectifier bridge connected to the stator windings contains six diodes, (three positive and three negative) molded into an assembly which is connected to the stator windings. This rectifier bridge changes the stator a.c. voltages to d.c. voltage which appears at the output terminal. The blocking action of the diodes prevent battery discharge back through the Delcotron generator.

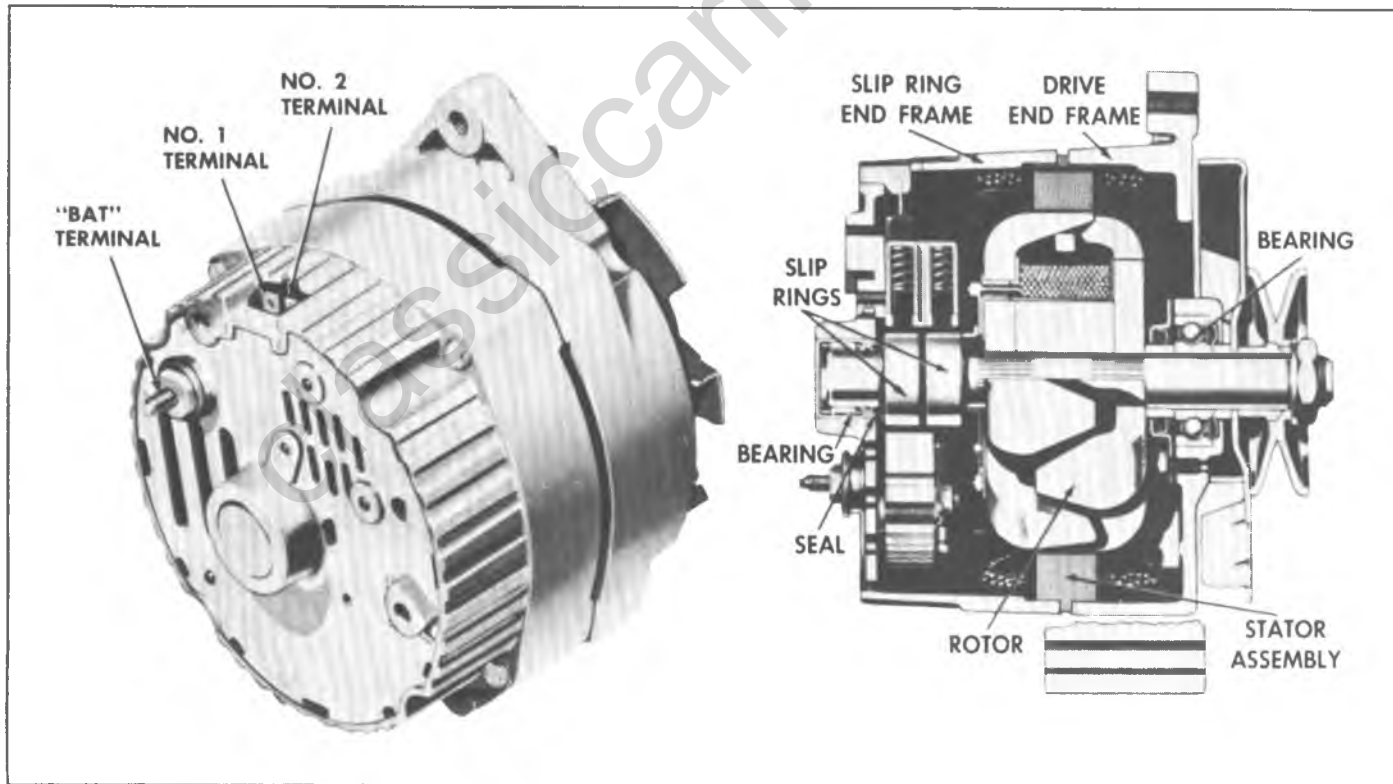

Fig. 1C—10-SI Series Delcotron

Because of this blocking action, the need for a cutout relay in the circuit is eliminated. Generator field current is supplied through a diode trio which is also connected to the stator windings.

A capacitor, or condenser, mounted in the end frame protects the rectifier bridge and diode from high voltages, and suppresses radio noise.

## THEORY OF OPERATION

The typical integral charging system is made up of two components--a Delcotron generator with a built-in solid state voltage regulator and an Energizer (battery). These components work together to supply electrical power for ignition, lights, radio, cranking motor, etc. A typical wiring diagram is illustrated in Figure 2C. The basic operating principles are explained as follows.

When the switch is closed, current from the energizer flows to the generator No. 1 terminal, through resistor R1, diode D1, and the base-emitter of transistor TR1 to ground, and then back to the battery. This turns on transistor TR1, and current flows through the generator field coil and TR1 back to the energizer. The indicator lamp then turns on.

With the generator operating, a.c. voltage is generated in the stator windings, and the stator supplies d.c. field current through the diode trio, the field, TR1, and then through the grounded diodes in the rectifier bridge back to the stator. Also, the six diodes in the rectifier bridge change the stator a.c. voltages to a d.c. voltage which

appears between ground and the generator "BAT" terminal. As generator speed increases, current is provided for charging the energizer and operating electrical accessories. Also, with the generator operating, the same voltage appears at the "BAT" and No. 1 terminals, and the indicator lamp goes out to indicate the generator is producing voltage.

The No. 2 terminal on the generator is always connected to the energizer, but the discharge current is limited to a negligible value by the high resistances of R2 and R3. As the generator speed and voltage increase, the voltage between R2 and R3 increases to the point where zener diode D2 conducts. Transistor TR2 then turns on and TR1 turns off. With TR1 off, the field current and system voltage decrease, and D2 then blocks current flow, causing TR1 to turn back on. The field current and system voltage increase, and this cycle then repeats many times per second to limit the generator voltage to a pre-set value.

Capacitor C1 smooths out the voltage across R3, resistor R4 prevents excessive current through TR1 at high temperatures, and diode D3 prevents high-induced voltages in the field windings when TR1 turns off.

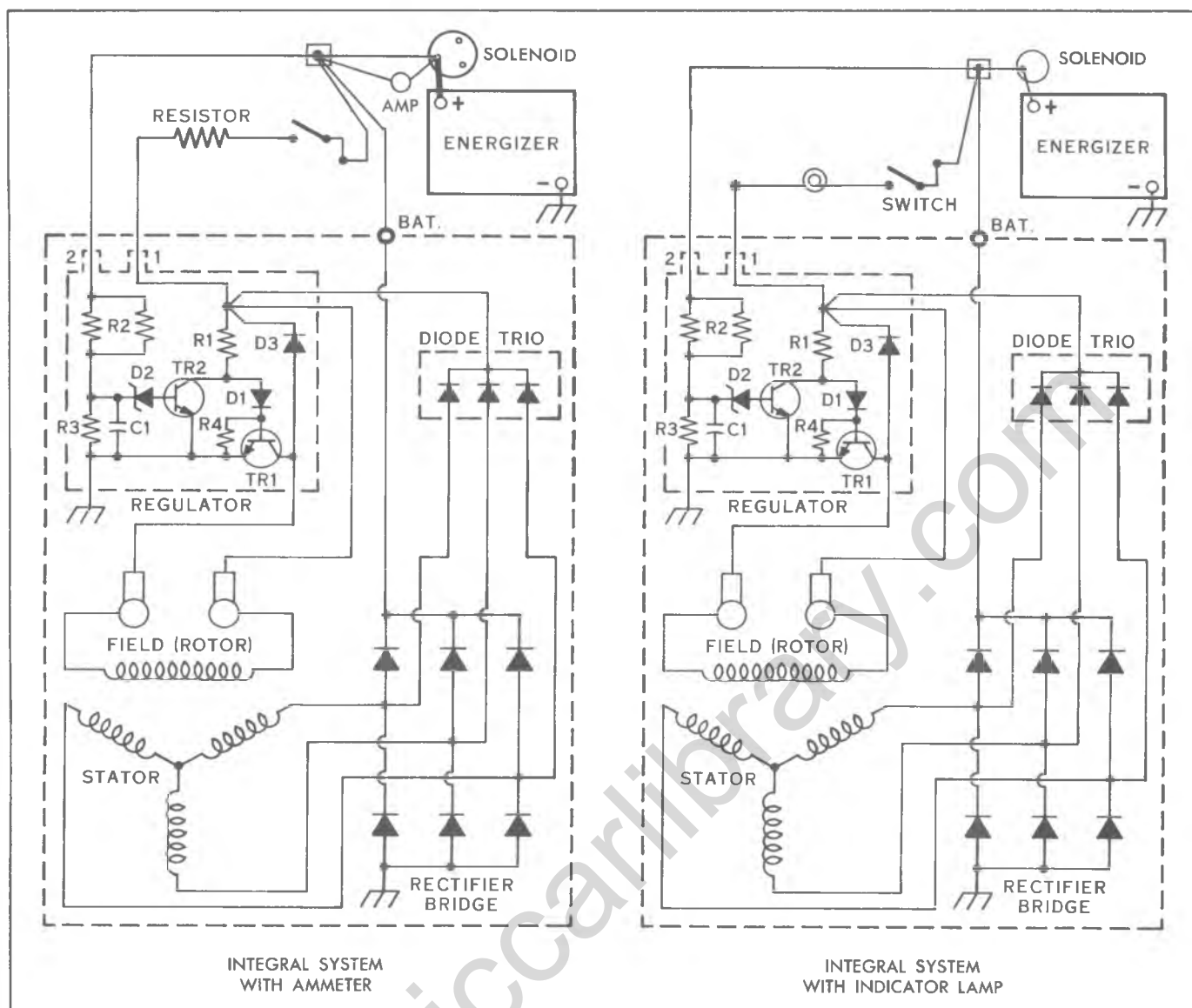

Fig. 2C—Integral Charging System Circuitry

## SERVICE OPERATIONS

### DELCOTRON ASSEMBLY

#### Replacement (Fig. 3C)

1. Disconnect the battery cables at battery.
2. Disconnect wiring leads at Delcotron.
3. Remove generator brace bolt, then detach drive belt (belts).
4. Support the generator and remove generator mount bolt and remove from vehicle.
5. Reverse the removal procedure to install then adjust drive belt(s) as outlined under tune-up, Section 6 of this manual.

### DELCOTRON PULLEY

#### Replacement

##### Single Groove Pulley

1. Place 15/16" box wrench on retaining nut and insert a 5/16" allen wrench into shaft to hold shaft while removing nut (fig. 4C).
2. Remove washer and slide pulley, fan and spacer from shaft.
3. Reverse Steps 1 and 2 to install, use a torque wrench with a crow-foot adapter (instead of box wrench) and torque the nut to 50 ft. lbs. (fig. 5C).

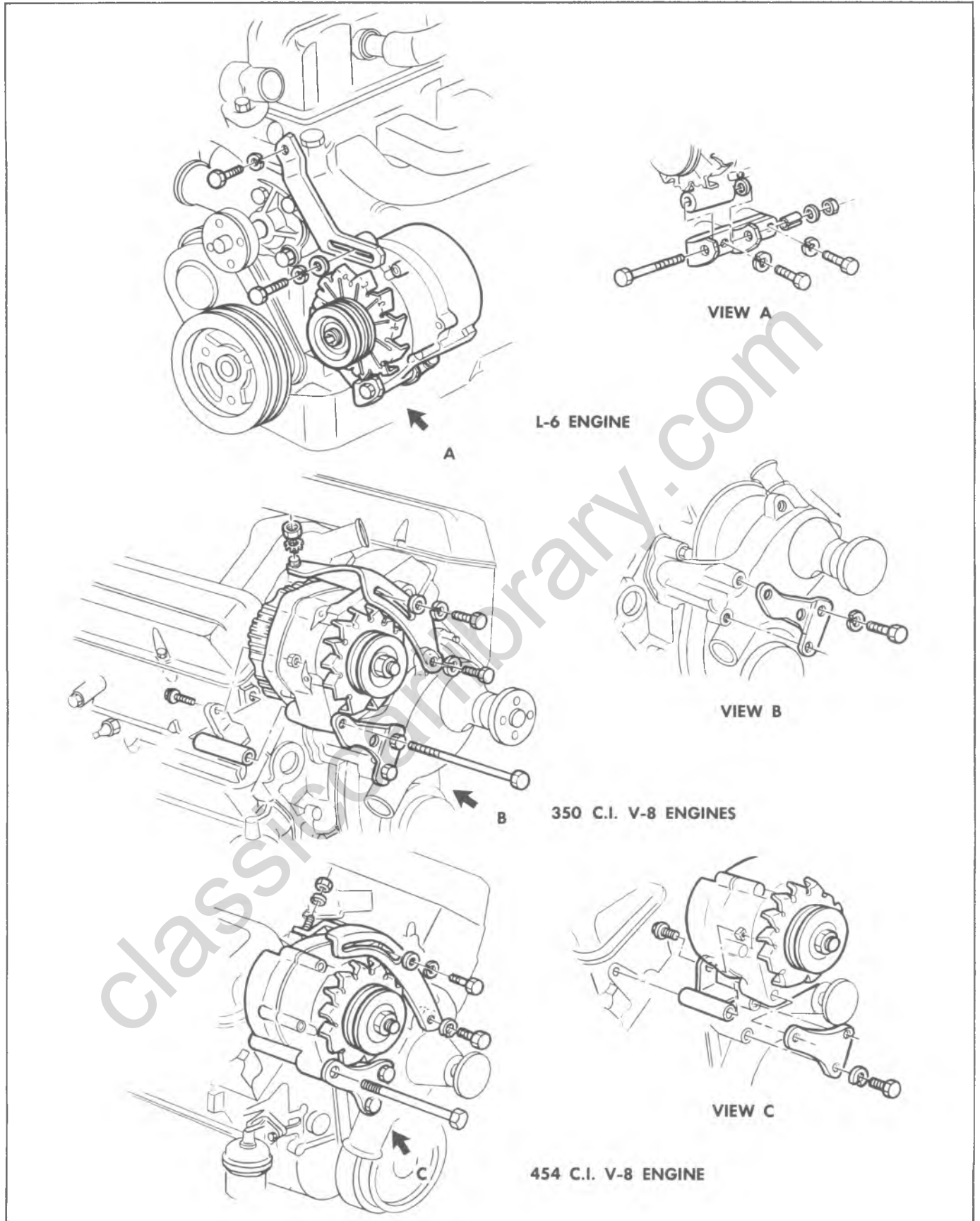

Fig. 3C—Delcotron Installation

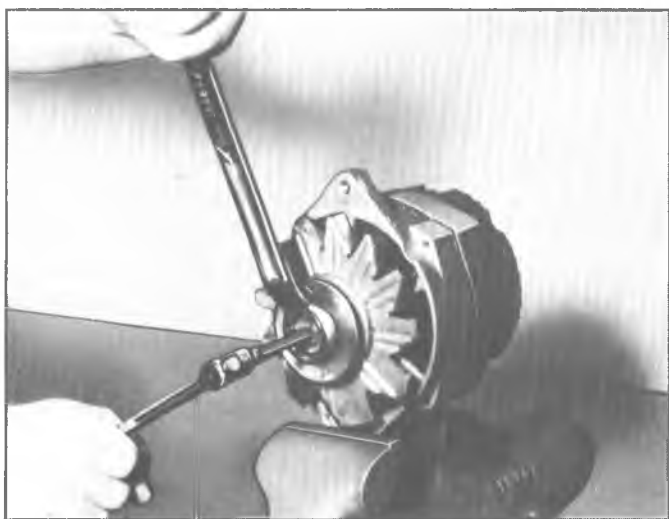

Fig. 4C—Pulley Removal

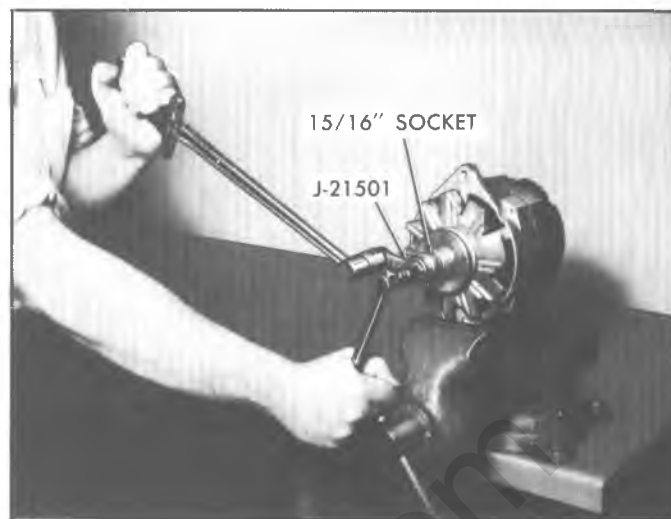

Fig. 5C—Torquing Pulley Nut

### Double Groove Pulley

1. Place a 15/16" socket (with wrench flats on the drive end or use Adapter J-21501 and a box wrench) on retaining nut, insert a 5/16" allen wrench through socket and adapter into hex on shaft to hold the shaft while removing the nut.

2. Remove washer and slide pulley, fan and spacer from shaft.
3. To install, slide spacer, fan, pulley and washer on shaft and start the nut.
4. Use the socket and adapter with a torque wrench and tighten nut to 50 ft. lbs. torque.

## DIAGNOSIS

Most charging system troubles show up as a faulty indicator lamp, an undercharged or an overcharged battery. Since the battery itself may be defective, it should be checked first to determine its condition. Also, in the case of an undercharged battery, check for battery drain caused by grounds or by accessories being left on.

A basic wiring diagram showing lead connections is presented in Figure 6C. The following precautions must be observed when working on the charging circuit. Failure to observe these precautions will result in serious damage to the electrical equipment.

- Do not polarize the generator.
- Do not short across or ground any of the terminals in the charging circuit except as specifically instructed in these procedures.
- Never operate the generator with the output terminal open circuited.
- Make sure the generator and Energizer are of the same ground polarity.
- When connecting a charger or a booster Energizer to the vehicle Energizer, connect negative terminal to negative terminal and positive terminal to positive terminal.

### STATIC CHECK

Before making any electrical checks, visually inspect all connections, including slip-on connectors, to make sure

they are clean and tight. Inspect all wiring for cracked, frayed or broken insulation. Be sure generator mounting bolts are tight and unit is properly grounded. Check for loose fan belt.

**NOTE:** In some circuits an ammeter may be used instead of an indicator lamp. In this case, the section pertaining to faulty indicator lamp operation may be omitted from the trouble shooting procedure.

### INDICATOR LAMP CIRCUIT CHECK

Check the indicator lamp for normal operation as shown below.

If the indicator lamp operates normally, proceed to "Undercharged Energizer" or "Overcharged Energizer" section. Otherwise, proceed to either one of the following three abnormal conditions.

1. Switch Off, Lamp On— In this case, disconnect the two leads from the generator No. 1 and No. 2 terminals. If the lamp stays on, there is a short between these two leads. If the lamp goes out, replace the rectifier bridge as covered in the Overhaul Manual. This condition will cause an undercharged Energizer.
2. Switch On, Lamp Off, Engine Stopped—This condition can be caused by the defects listed in step 1 above, by reversal of the No. 1 and No. 2 leads at



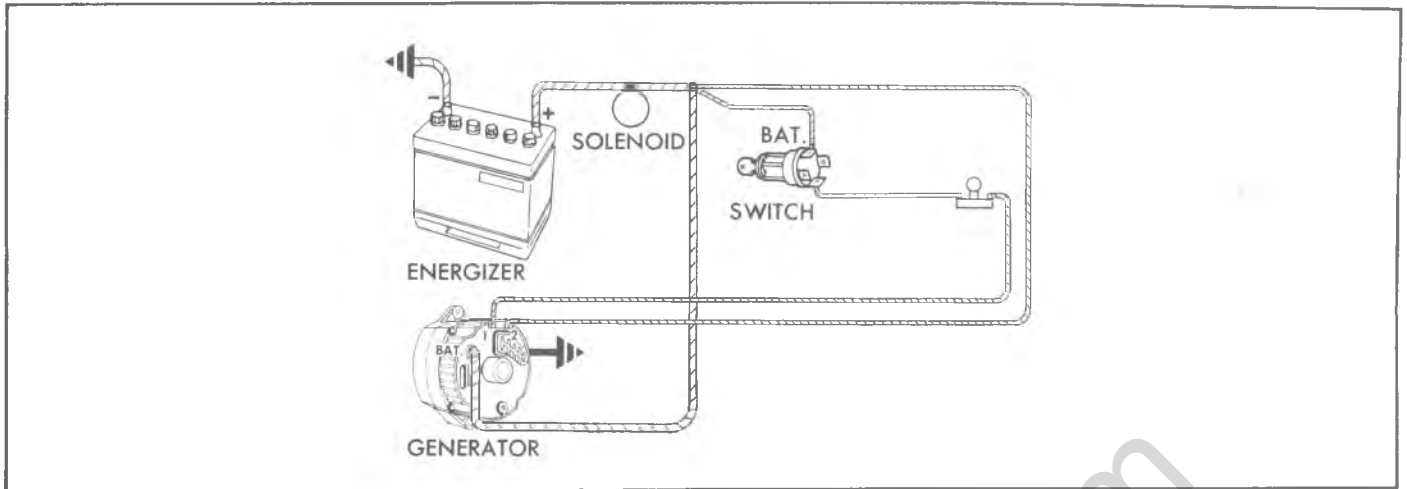

Fig. 6C—Basic Wiring Diagram

Switch	Lamp	Engine
OFF	OFF	STOPPED
ON	ON	STOPPED
ON	OFF	RUNNING

these two terminals, or by an open in the circuit. This condition can cause an undercharged Energizer. To determine where an open exists, proceed as follows:

- Connect voltmeter from No. 2 generator terminal to ground. If reading is obtained, go to step b. If reading is zero, repair open circuit between No. 2 terminal and Energizer. If lamp now comes on, no further checks need be made.
- With ignition switch on and with No. 1 and No. 2 terminal leads disconnected, at generator, momentarily ground No. 1 terminal lead.

**CAUTION:** Do not ground No. 2 lead.

- If lamp does not light, check for a blown fuse, or fusible link, a burned out bulb, defective bulb socket, or an open in No. 1 lead circuit between generator and ignition switch.
- If lamp lights, remove ground at No. 1 terminal and with No. 1 and No. 2 terminal leads connected at generator, insert screwdriver into test hold (fig. 7C) to ground winding.
- If lamp does not light, check connection between wiring harness and No. 1 terminal of generator, and check brushes, slip rings, and field winding as covered in Overhaul Manual.
- If lamp lights and voltmeter reading is obtained in step a, replace regulator as covered in the Overhaul Manual.

- Switch On, Lamp On, Engine Running—The possible causes of this condition are covered in the "UNDERCHARGED ENERGIZER" section.

### UNDERCHARGED ENERGIZER CONDITION CHECK

This condition, as evidenced by slow cranking and low specific gravity readings, can be caused by one or more of the following conditions even though the ammeter may be operating normally.

- Insure that the undercharged condition has not been caused by accessories having been left on for extended periods.
- Check the drive belt for proper tension.

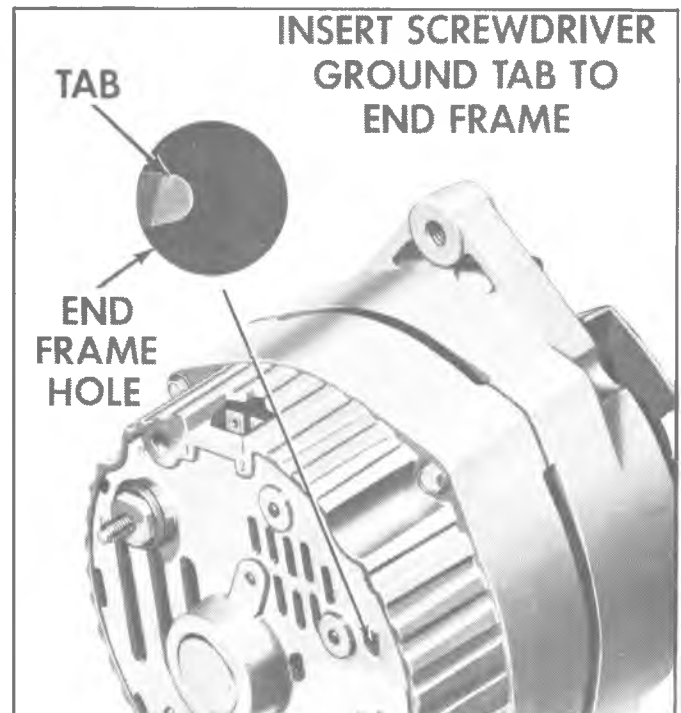

Fig. 7C—Delcotron End View

3. Check energizer. Test is not valid unless energizer is good and fully charged.
4. Inspect the wiring for defects. Check all connections for tightness and cleanliness, including the slip connectors at the generator and firewall, and the cable clamps and battery posts.
5. With ignition switch "on" connect a voltmeter from generator "BAT" terminal to ground, generator No. 1 terminal to ground and generator No. 2 terminal to ground. A zero reading indicates an open between voltmeter connection and Energizer.

**NOTE:** An open No. 2 lead circuit on generators will cause uncontrolled voltage, Energizer overcharge and possible damage to Energizer and accessories. Generators supplied for current applications have a built-in feature which avoids overcharge and accessory damage by preventing the generator from turning on if there is an open in the wiring harness connected to the No. 2 generator terminal. Opens in the wiring harness connected between the No. 2 generator terminal and Energizer may be between the terminals, at the crimp between the harness wire and terminal, or in the wire.

6. If previous Steps 1 through 5 check satisfactorily, check Delcotron generator as follows:
  - a. Disconnect Battery ground cable.
  - b. Connect an ammeter in the circuit at the "BAT" terminal of the generator.
  - c. Reconnect Battery ground cable.
  - d. Turn on radio, windshield wipers, lights high beam and blower motor high speed. Connect a carbon pile across the Battery.
  - e. Operate engine at moderate speed as required, and adjust carbon pile as required, to obtain maximum current output.
  - f. If ampere output is within 10 percent of rated output as stamped on generator frame, generator is not defective; recheck Steps 1 through 5.
  - g. If ampere output is not within 10 percent of rated output, ground the field winding by inserting a screwdriver into the test hole (Fig. 7C).

**CAUTION:** Tab is within 3/4 inch of casting surface. Do not force screwdriver deeper than one inch into end frame.

- h. Operate engine at moderate speed as required, and adjust carbon pile as required to obtain maximum current output.
- i. If output is within 10 percent of rated output, replace regulator as covered in the Overhaul Manual and check field winding.
- j. If output is not within 10 percent of rated output, check the field winding, diode trio,

rectifier bridge, and stator as covered in the Chassis Overhaul Manual.

- k. Remove ammeter from generator and turn accessories off.

## OVERCHARGED ENERGIZER CONDITION CHECK

1. Determine Energizer condition. Test is not valid if Energizer is not good and fully charged.
2. Connect a voltmeter from generator No. 2 terminal to ground. If reading is zero, No. 2 lead circuit is open.
3. If Energizer and No. 2 lead circuit check good, but an obvious overcharge condition exists as evidenced by excessive Energizer water usage, proceed as follows:
  - a. Separate end frames as covered in Delcotron "Disassembly" section in the Overhaul Manual. Check field winding for shorts. If shorted replace rotor and regulator.
  - b. Connect ohmmeter using lowest range scale from brush lead clip to end frame as shown in Step 1, Figure 8C, then reverse lead connections.
  - c. If both readings are zero, either the brush lead clip is grounded, or regulator is defective.
  - d. A grounded brush lead clip can result from omission of insulating washer (Fig. 8C), omission of insulating sleeve over screw, or damaged insulating sleeve. Remove screw to inspect sleeve. If satisfactory, replace regulator as covered in the Overhaul Manual.

## GENERATOR OUTPUT TEST

To check the generator in a test stand, proceed as follows:

1. Make connections as shown in Figure 9C, except leave the carbon pile disconnected. Use a fully charged Energizer or battery, and a 10 ohm resistor rated at six watts or more between the generator No. 1 terminal and the Energizer.
2. Slowly increase the generator speed and observe the voltage.
3. If the voltage is uncontrolled with speed and increases above 16 volts, check for a grounded brush lead clip as covered under heading of "OVERCHARGED ENERGIZER", Step 3. If not grounded, replace the regulator.

**NOTE:** The Energizer must be fully charged when making this check.

4. Connect the carbon pile as shown.
5. Operate the generator at moderate speed as required and adjust the carbon pile as required to obtain maximum current output.

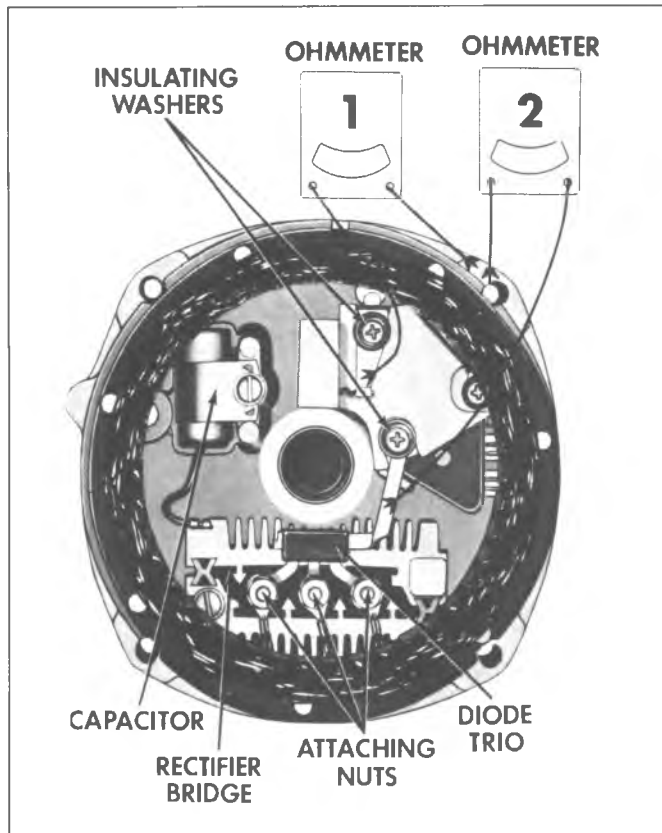

Fig. 8C—Slip Ring End Frame

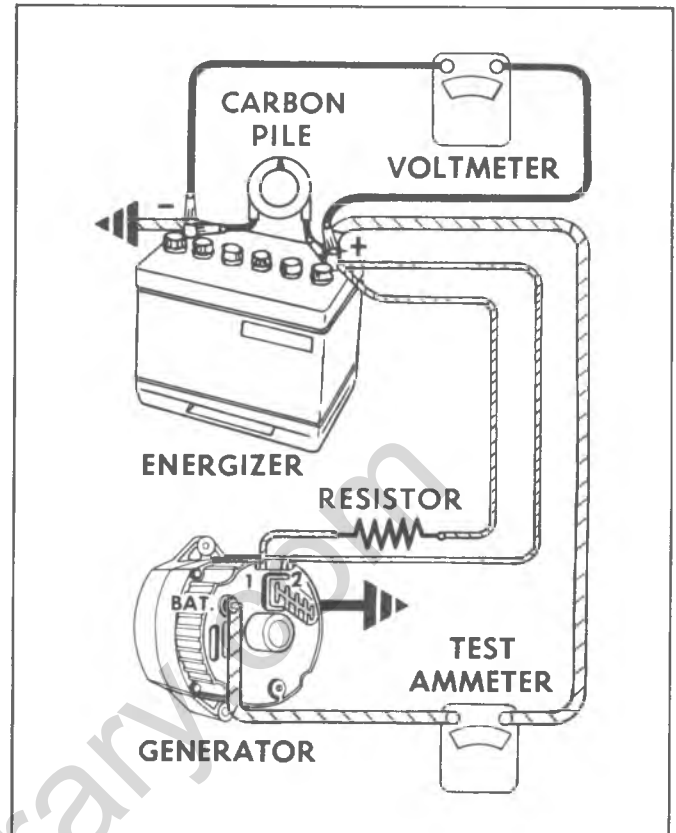

Fig. 9C—Generator Output Test

6. If output is within ten percent of rated output as stamped on generator frame, generator is good.
7. If output is not within ten percent of rated output, ground generator field (Fig. 7C).
8. Operate generator at moderate speed and adjust carbon pile as required to obtain maximum output.
9. If output is within ten percent of rated output, replace regulator as covered in "Regulator Replacement" section.
10. If output is not within ten percent of rated output, check the field winding, diode trio, rectifier bridge and stator as previously covered.

### OTHER HARNESS CHECKS

Wires in the charging system may be checked for continuity by use of an ohmmeter or a test light (12 volt). Connect the test so the wire in question is in series in the test circuit.

# IGNITION SYSTEMS

## INDEX

General Description .....	6Y-24	Removal.....	6Y-38
Theory of Operation.....	6Y-26	Disassembly .....	6Y-38
Components .....	6Y-27	Cleaning and Inspection .....	6Y-39
Distributors .....	6Y-27	Assembly .....	6Y-39
Spark Advance Systems .....	6Y-27	Installation .....	6Y-39
Cam Angle .....	6Y-30	Off-Engine Test .....	6Y-41
Ignition Condenser (Capacitor).....	6Y-30	Coil Replacement.....	6Y-41
Ignition Coil.....	6Y-31	Spark Plug and Wire Service.....	6Y-41
Spark Plugs.....	6Y-31	Removal and Inspection.....	6Y-41
Secondary Ignition Cables.....	6Y-32	Spark Plug Cleaning.....	6Y-42
Ignition Switch.....	6Y-32	Adjust Plug Gap.....	6Y-42
Adjustments and Repairs.....	6Y-34	Installation of Plugs.....	6Y-42
Distributor Contact Points.....	6Y-34	Installation of Plug Wires.....	6Y-42
Cleaning .....	6Y-34	Diagnosis.....	6Y-44
Replacement .....	6Y-34	Ignition System.....	6Y-44
Setting Dwell Angle.....	6Y-35	Ignition Coil Test .....	6Y-45
Distributor Condenser.....	6Y-37	Distributor Condenser Test.....	6Y-45
Performance Diagnosis.....	6Y-37	Ignition System Resistance Test .....	6Y-46
Replacement .....	6Y-38	Spark Plugs.....	6Y-46
Distributor.....	6Y-38		

## GENERAL DESCRIPTION

The ignition system used on all models is the standard breaker point type consisting of a coil, condenser, distributor, switch, wiring, spark plugs and a source of electrical energy. The distributor contact points set, condenser, cam lubricator and spark plugs are the only system components that require periodic service. The remainder of the ignition system requires only periodic inspection to check the operation of the components, tightness of electrical connections, and condition of the wiring.

Two types of distributors are used: an internal adjustment distributor on 6 cylinder engines (fig. 1i) and an external adjustment distributor on 8 cylinder engines (fig. 2i). Both function in much the same manner to - (1) cause a higher voltage surge from coil, (2) time these surges with regard to engine requirements through use of centrifugal and vacuum advance mechanisms, and (3) direct high voltage surges through distributor rotor, cap, and high tension wiring to the spark plugs.

The distributor houses the contact points that make and break the primary circuit, and also directs high voltage and current in proper sequence to the spark plugs. The contact point set is replaced as a complete assembly. The breaker lever spring tension and point alignment on the replacement set are factory adjusted, leaving only the dwell angle to be adjusted after installation.

The distributors are equipped with a cam lubricator, which should be rotated 180 degrees every 12,000 miles and replaced every 24,000 miles. Do not attempt to

lubricate the element, but replace when necessary. Distributor shaft lubrication is accomplished by a reservoir of lube around the mainshaft in the distributor bowl.

The rotor located above the breaker plate assembly serves as a cover for the centrifugal advance mechanism, and distributes high voltage and current to fire the spark plugs. When the rotor is removed, the centrifugal advance mechanism should be inspected for lubricant. If necessary, a small amount of cam and bearing lubricant should be applied to the advance weights.

The ignition coil (fig. 3i) is an oil filled, hermetically sealed unit designed specifically for use with an external resistance. The number of turns in the primary winding results in a high inductance in this winding, which makes it possible for the coil to provide a higher secondary voltage output throughout the speed range. The primary current from the ignition switch passes through a resistance wire which lowers the voltage to approximately 9 volts. This lower voltage provides for longer contact life.

For optimum starting performance, the resistance is bypassed during cranking, thereby connecting the ignition coil directly to the battery. This provides full battery voltage at the coil and keeps ignition voltage as

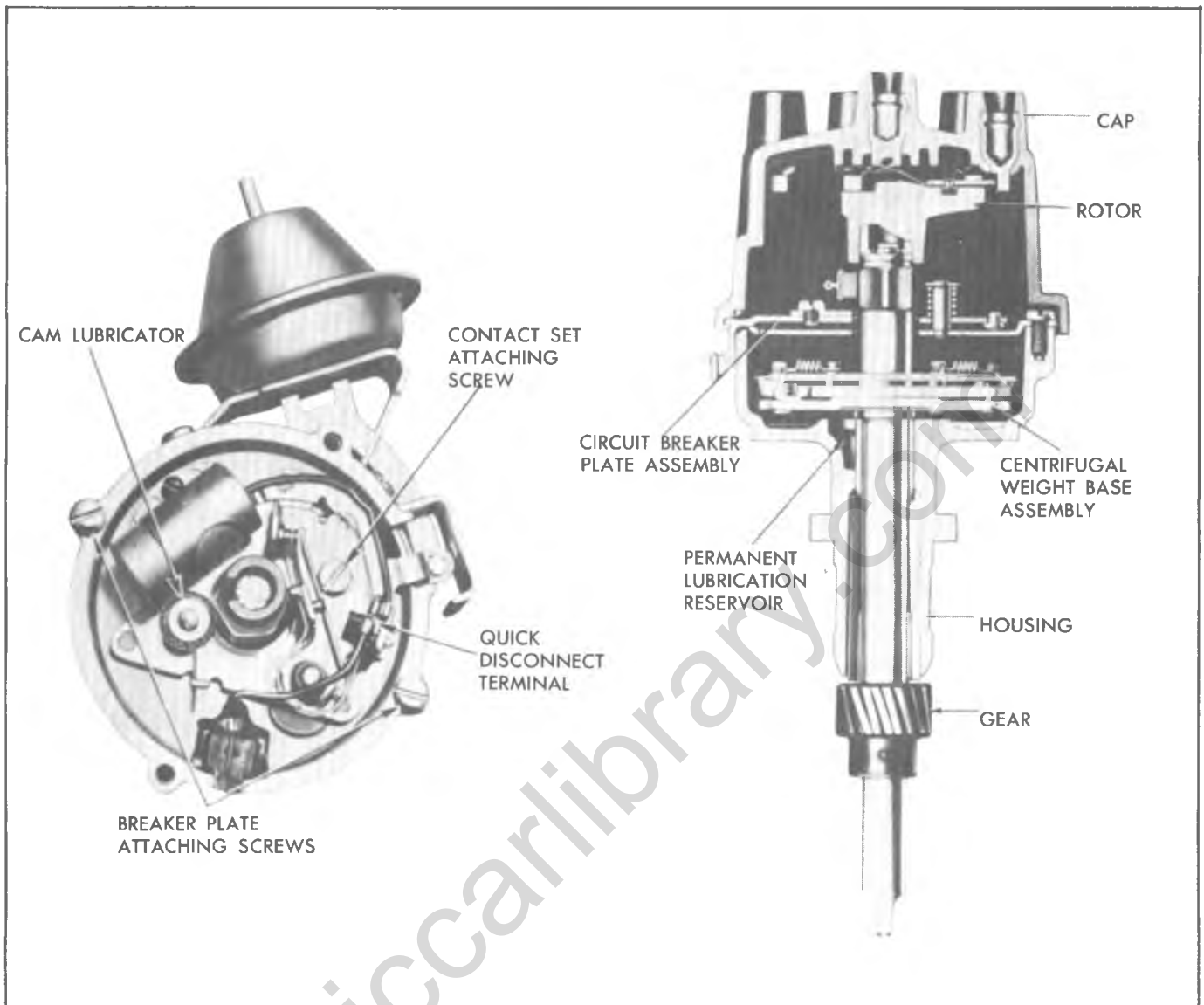

Fig 1i-6 Cylinder Distributor

high as possible during cranking. The resistance is bypassed automatically through the ignition and starting switch when the switch is in the "Start" position.

The secondary ignition cables in the secondary or high tension system (coil to distributor and distributor to plugs) are resistant to grease, battery acid and road salt, and offers resistance to corona breakdown. Ignition cables have a multiple cloth thread core impregnated with a graphite solution to give the correct conductivity.

The spark plugs used are a resistor type, tapered seat plug. The plugs have a type number on the insulator which designates thread size as well as relative position of the plug in the heat range. Type numbers (First Digit) starting with 4 are 14 mm, thread size. The last digit of the type number indicates the heat range position of the plug. The higher the number the hotter the plug. Spark plugs should be checked, cleaned, regapped or replaced at least every 12 months or 12,000 miles when using non-leaded fuels or at 6,000 miles when using leaded fuels.

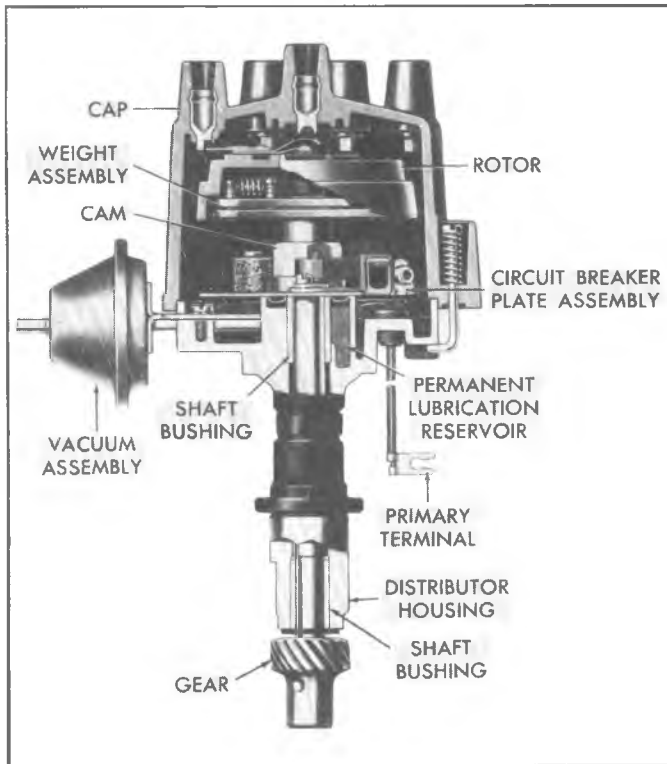

Fig. 2i-8 Cylinder Distributor

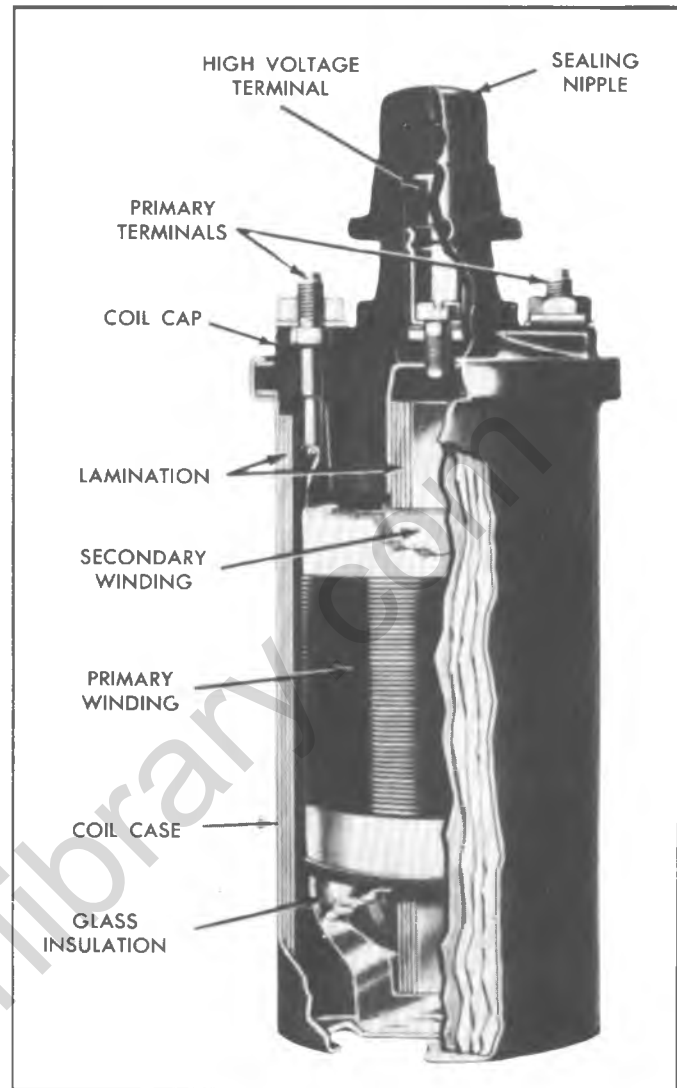

Fig. 3i-Ignition Coil

## THEORY OF OPERATION

The basic ignition system (Fig. 4i) consists of the ignition coil, condenser, ignition distributor, ignition switch, low and high tension wiring, spark plugs, and a source of electrical energy (battery or generator). The ignition system has the function of producing high voltage surges and directing them to the spark plugs in the engine cylinders. The sparks must be timed to appear at the plugs at the correct instant near the end of the compression stroke with relation to piston position. The spark ignites the fuel-air mixture under compression so that the power stroke follows in the engine.

There are two separate circuits through the ignition system. One of these is the primary circuit which includes the ignition switch, primary winding of the ignition coil, distributor contact points and condenser. The other is the secondary or high tension circuit which

includes the secondary winding of the ignition coil, the high tension lead, distributor cap, rotor and spark plugs.

The basic operation is described as follows: With the switch closed, current flows through the primary circuit; that is from the battery through the primary winding of the ignition coil and closed distributor contacts to ground, and then back to the battery. A cam mounted on the rotating distributor shaft causes the distributor contacts to open and close. When the contacts open, the current decreases very rapidly in the ignition coil primary winding, and a high voltage is induced in the coil secondary winding.

This high voltage is impressed through the distributor cap and rotor across one of the spark plugs. As the voltage establishes an arc across the spark plug

electrodes, the air-fuel mixture in the cylinder is ignited to provide the power stroke.

The secondary electrons flow from the coil secondary winding, across the distributor rotor gap and spark plug gap, and then back to the secondary winding through ground, the battery and switch. The distributor contacts then reclose, and the cycle repeats. The next-firing spark plug then will be the one connected to the distributor cap insert that is aligned with the rotor when the contacts separate. With the engine running, current flows through the coil primary calibrated resistance wire; the other lead connected between the coil and solenoid terminal is a bypass feature that will be covered in the section entitled "Ignition Coils".

When the contacts separate, a high voltage is induced in the coil primary winding. This voltage may be as high as 250 volts, which causes an arc to form across the distributor contacts. To bring the primary current to a quick controlled stop, and in order to greatly reduce the size of the arc and thereby insure prolonged contact point life, a capacitor (condenser) is connected across the distributor contacts.

## COMPONENTS

### Distributor

The distributor has three jobs. First, it opens and closes the low tension circuit between the source of electrical energy and the ignition coil so that the primary winding is supplied with intermittent surges of current. Each surge of current builds up a magnetic field in the coil. The distributor then opens its circuit so that the magnetic field will collapse and cause the coil to produce a high voltage surge. The second job that the distributor has is to time these surges with regard to the engine requirements. This accomplished by the centrifugal and vacuum advance mechanisms. Third, the distributor directs the high voltage surge through the distributor rotor, cap and high tension wiring to spark plug which is ready to fire.

The typical contact point type ignition distributor (Figs. 1i and 2i), consists of a housing, shaft, centrifugal advance assembly, vacuum advance assembly, breaker plate assembly, capacitor or condenser, and rotor.

The cap, rotor, and high voltage leads in a distributor form a distribution system that conveys the high voltage surges to the spark plugs in correct sequence.

The breaker plate contains the breaker lever, contact support, and capacitor. When the breaker cam rotates, each cam lobe passes by and contacts the breaker lever rubbing block, separating the contact points and producing a high voltage surge in the ignition system. With every breaker cam revolution, one spark will be produced for each engine cylinder. Since each cylinder fires every other revolution in a four-cycle engine, the distributor rotates at one-half engine speed.

The shaft and weight base assembly is fitted in suitable bearings made of such materials as cast iron, bronze, or

iron. Centrifugal advance weights are pivoted on studs in the weight base, and are free to move against calibrated weight springs which connect them to the breaker cam assembly. The breaker cam assembly fits on the top of the shaft (slip fit) and rotates with the shaft, being driven by the weight springs actuated by the advance weights.

Outward movement of the weights advances the cam assembly in relation to the shaft as engine speed is increased, providing an earlier spark. Each engine model requires an individual spark advance curve to insure delivery of the spark at the right instant for maximum power at all speeds. Because of this, very little standardization of complete distributors can be made.

It is possible to improve fuel economy on engines operating under part-throttle conditions by supplying additional spark advance. Vacuum advance mechanisms are provided on some distributors for this purpose. The mechanism used rotates either the complete distributor or the breaker plate in order to time the spark earlier when the engine is operating at part throttle.

## Spark Advance Systems

### Centrifugal Advance

The centrifugal advance mechanism times the high voltage surge produced by the ignition coil so that it is delivered to the engine at the correct instant, as determined by engine speed.

When the engine is idling, the spark is timed to occur in the cylinder just before the piston reaches top dead center. At higher engine speeds, however, there is a shorter interval of time available for the fuel-air mixture to ignite, burn, and give up its power to the piston. Consequently, in order to obtain the maximum amount of power from the mixture, it is necessary at higher engine speeds for the ignition system to deliver the high voltage surge to the cylinder earlier in the cycle.

To illustrate this principle, assume that the burning time of a given gas mixture in an automotive engine is .003 of a second. To obtain full power from combustion, maximum pressure must be reached while the piston is between 10 degrees and 20 degrees past top dead center. At 1,000 engine r.p.m., the crankshaft travels through 18 degrees in .003 of a second, at 2,000 r.p.m., the crankshaft travels through 36 degrees. See Fig. 5i. Since maximum pressure point is fixed, it is easy to see why the spark must be delivered into the cylinder earlier in the cycle in order to deliver full power, as engine speed increases.

As previously mentioned, the timing of the spark to engine speed is accomplished by the centrifugal advance mechanism, which is assembled on the distributor shaft. The mechanism consists primarily of two weights and a cam assembly. The weights throw out against spring tension as engine speed increases. This motion of the weights turns the cam assembly so that the breaker cam is rotated in the direction of shaft rotation to advanced position with respect to the distributor drive shaft. The

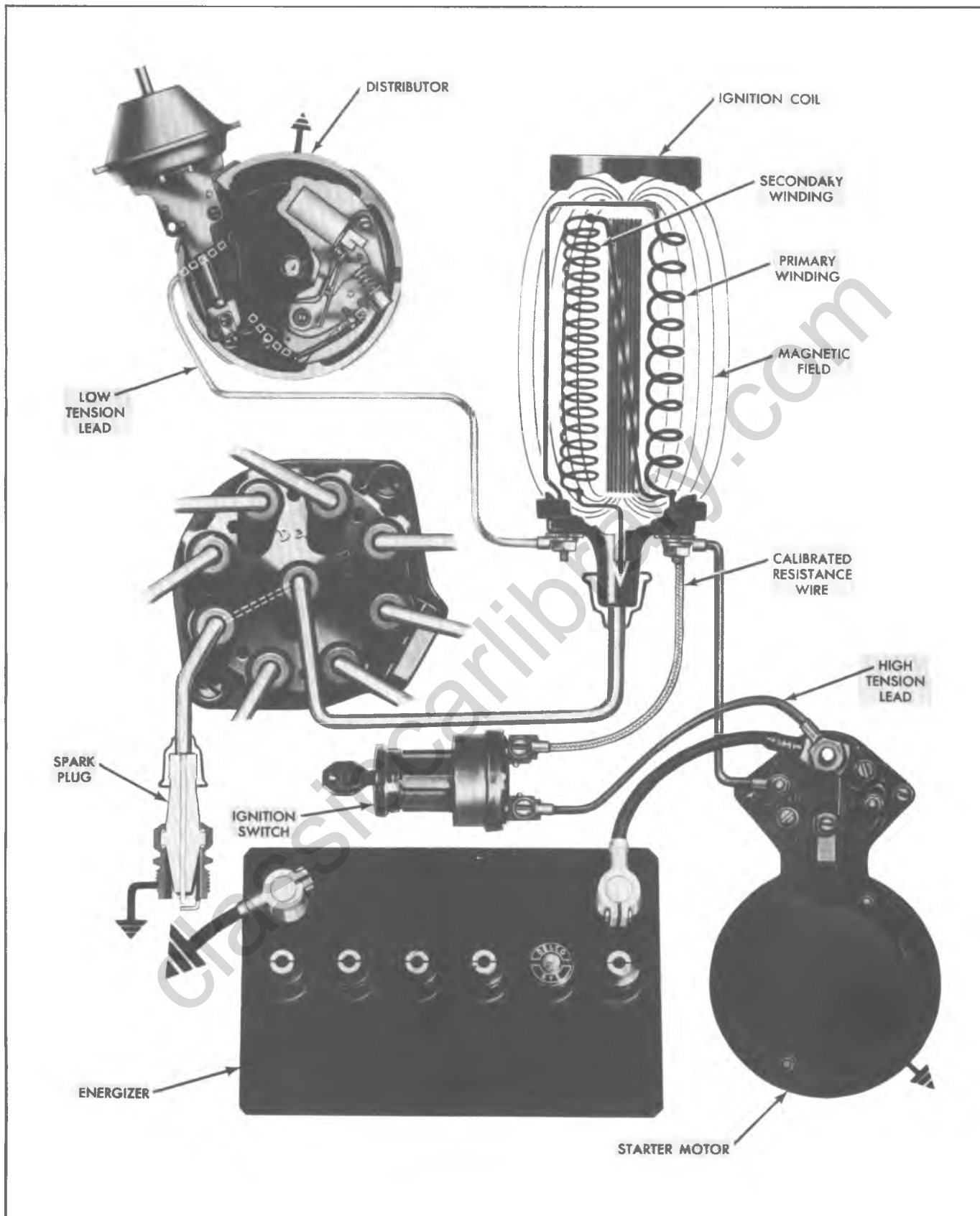

Fig. 4i—Typical Ignition System



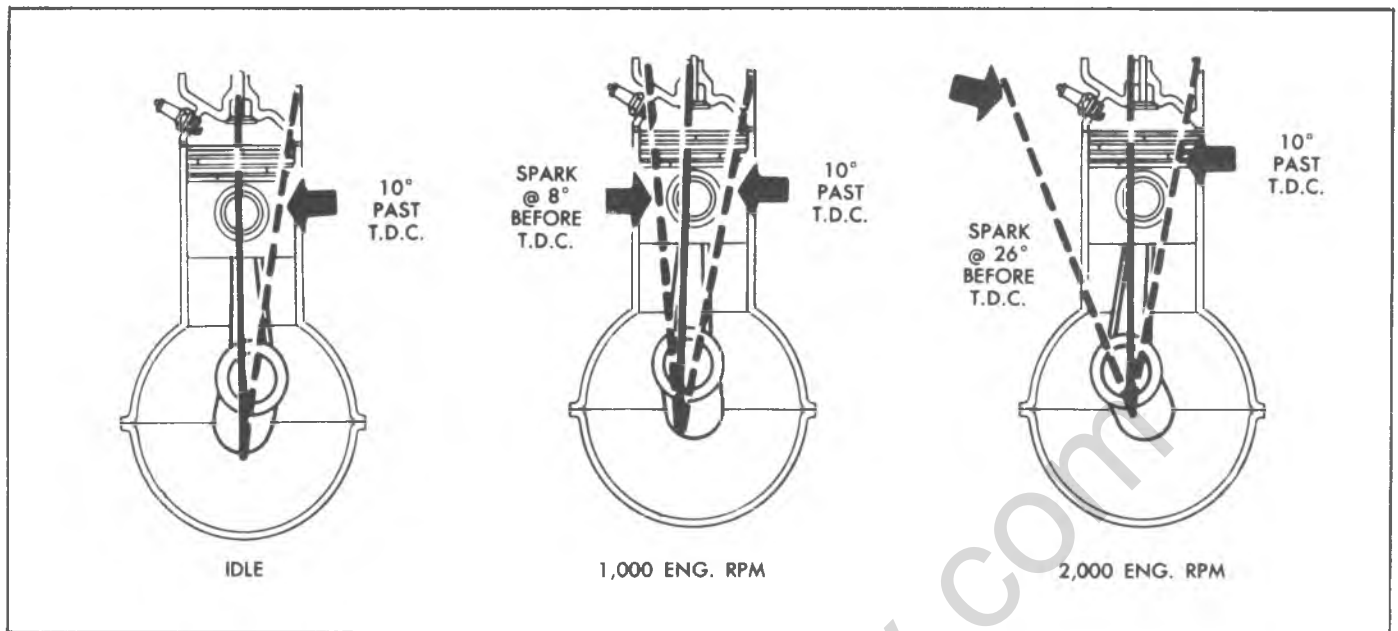

Fig. 5i—Ignition Spark vs Engine Speed

higher the engine speed, the more the weights throw out and the further the breaker cam is advanced. See Fig. 6i.

The centrifugal advance required varies considerably between various engine models. In order to determine the advance for a given engine, the engine is operated on a dynamometer at various speeds with a wide-open throttle. Spark advance is varied at each speed until the range of advance that gives maximum power is found. The cam assembly, weights and springs are then selected to give this advance. Timing, consequently, varies from no advance at idle to full advance at high engine speed where the weights reach the outer limits of their travel.

#### Vacuum Advance

Under part-throttle operation a high vacuum develops in the intake manifold and a smaller amount of air and gasoline enters the cylinder. Under these conditions, additional spark advance (over and above advance provided by the centrifugal advance mechanism) will

increase fuel economy. In order to realize maximum power, ignition must take place still earlier in the cycle.

To provide a spark advance based on intake manifold vacuum conditions, many distributors are equipped with a vacuum advance mechanism. The mechanism has a spring-loaded diaphragm connected by linkage to the distributor. The spring-loaded side of the diaphragm is air-tight, and is connected in many cases by a vacuum passage to an opening in the carburetor. See Fig. 7i. This opening is on the atmospheric side of the throttle when the throttle is in the idling position. In this position, there is no vacuum in the passage.

When the throttle is partly opened, it swings past the opening of the vacuum passage. Intake manifold vacuum then can draw air from the air-tight chamber in the vacuum advance mechanism and this causes the diaphragm to be moved against the spring. This motion is transmitted by linkage to the distributor breaker assembly rotation is governed by the amount of vacuum in the intake manifold up to the limit imposed by the design of the vacuum advance mechanism.

When the distributor breaker plate assembly is rotated, the contact points are carried around the breaker cam to an advanced position, so that the breaker cam contacts the rubbing block and closes and opens the points earlier in the cycle. This provides a spark advance based on the amount of vacuum in the intake manifold. Thus, for varying compressions in the cylinder the spark advance will vary, permitting greater economy of engine operation. It should be recognized that the additional advance provided by vacuum control is effective in providing additional economy only on PART-THROTTLE operation.

At any particular engine speed there will be a certain definite advance resulting from operation of the

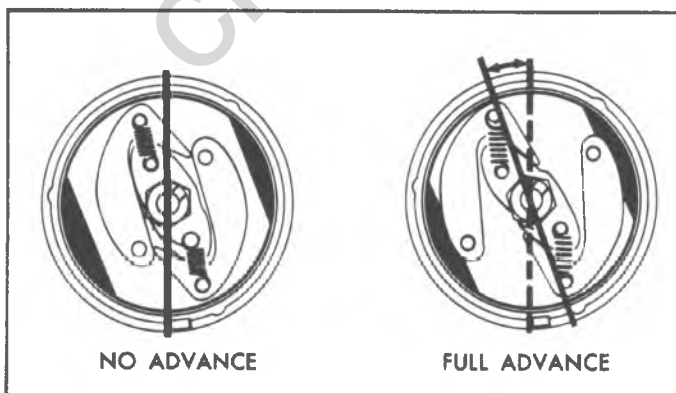

Fig. 6i—Centrifugal Advance Mechanism

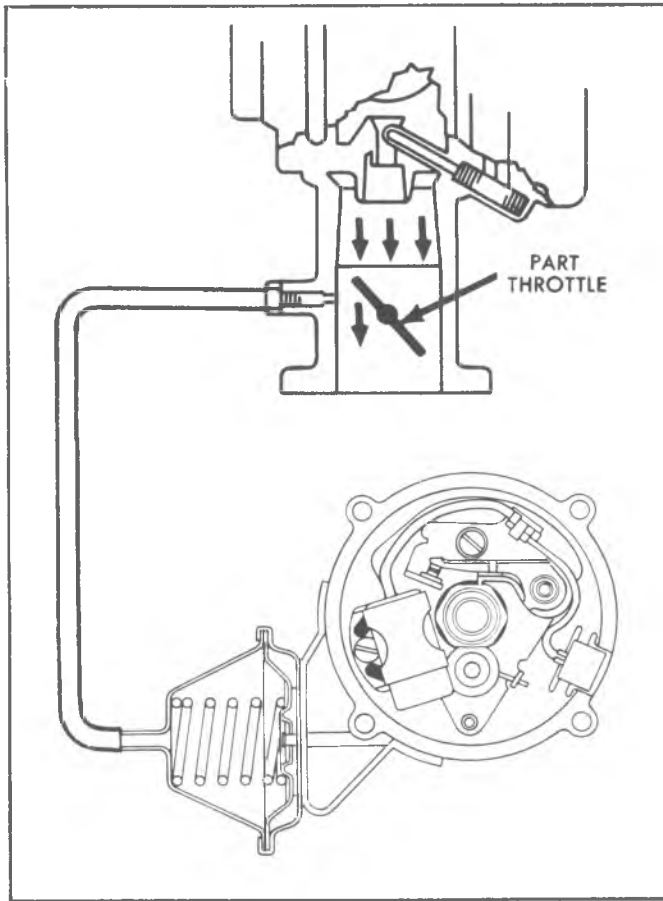

Fig. 7i—Vacuum Advance Mechanism

centrifugal advance mechanism, plus a possible additional advance resulting from operation of the vacuum advance mechanism. For example, an initial timing advance of 5 degrees, plus a centrifugal advance of 10 degrees, makes a total of 15 degrees advance at 40 miles an hour. If the throttle is only partly opened, an additional vacuum advance of up to 15 degrees more may be obtained, making a total of 30 degrees. When the throttle is wide open there is no appreciable vacuum in the intake manifold, so this additional advance will not be obtained. All advance then is based on engine speed alone and is supplied by the centrifugal advance mechanism.

The vacuum advance mechanism is an economy device which will increase fuel economy when properly used. The driver who drives with wide-open throttle whether in low or high gear will not obtain this additional advance with its resulting increased fuel economy.

### Cam Angle

The cam angle, often referred to as contact angle or dwell angle, is the number of degrees of cam rotation during which the distributor contact points remain closed. See Fig. 8i. It is during this period of cam rotation that the current in the primary winding increases. Although the cam angle may not change, the length of time the contacts remain closed becomes less

and less as the engine speed increases. At higher engine speeds, the ignition coil primary current does not reach its maximum value in the short length of time the contacts are closed. In order to store the maximum amount of energy obtainable on the coil, and consequently obtain sufficient energy to fire the plug, it is necessary to design a breaker lever assembly that will operate properly at high speeds. The distributor is equipped with a special-high rate-of-break cam and a special high speed breaker lever which is capable of following the cam shape at high speeds without bouncing. The high rate-of-break cam separates the contact points faster for each degree of rotation and permits closing earlier, thus increasing cam angle. With the special cam and breaker lever combination, it is possible to obtain the maximum cam angle and consequently optimum ignition performance at high speeds.

The point opening is the maximum distance that occurs between the separated contacts as the cam rotates. If the cam angle is properly set, the point opening most likely will also be according to specifications. In some cases, it may be necessary to measure point opening in addition to cam angle to insure that the contacts are properly set. A feeler gauge on new contacts, or a dial indicator on used contacts may be used to measure point opening.

### Ignition Condenser (Capacitor)

The capacitor consists of a roll of two layers of thin metal foil separated by a thin sheet or sheets of insulating material. (Fig. 9i). This assembly is sealed in a metal can with a flat spring washer providing a tight seal.

The high voltage induced in the coil primary causes the capacitor plates to charge when the contacts first

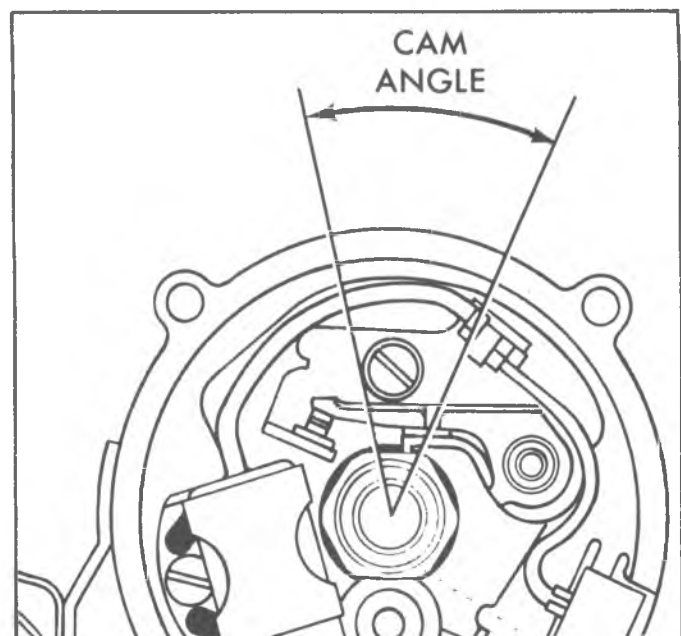

Fig. 8i—Cam Angle

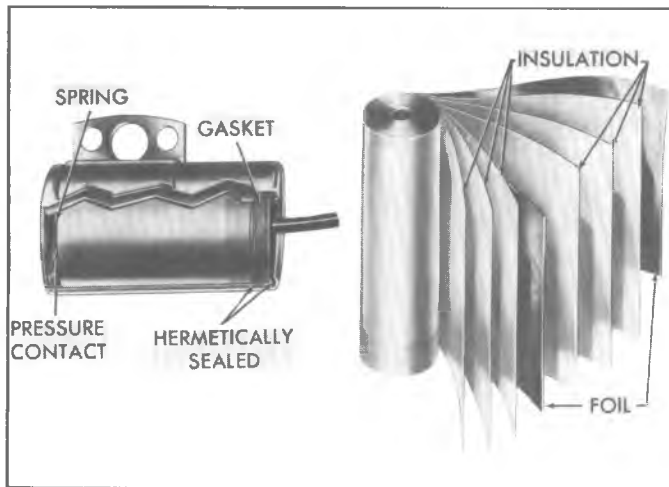

Fig. 9i—Ignition Condenser

separate; the capacitor acts initially like a short circuit and current flows into the capacitor to minimize arcing at the contacts.

### Ignition Coil

An ignition coil is a pulse transformer that steps up the low voltage from the battery or generator to a voltage high enough to ionize the spark plug gap and ignite the air-fuel mixture in the cylinder. A typical coil is made up of a primary winding, consisting of a few hundred turns of relatively large wire, and a secondary winding, consisting of many thousand turns of very small wire (Fig. 3i). These windings are assembled over a soft iron core and are enclosed by a soft iron shell. This assembly is inserted into a one-piece, steel or diecast aluminum coil case, which is filled with oil and hermetically sealed by a coil cap made of molded insulating material. The cap contains the primary and secondary high voltage terminals.

The ignition coils are hermetically sealed to prevent the entrance of moisture, which would cause coil failure. During manufacture, the coil case also is filled with oil at a high temperature. As the oil temperature decreases to more nearly match the temperature of the surrounding air, the oil contracts to occupy less volume thus allowing room for expansion when the coil heats up during normal operation. The oil acts as an insulator to prevent high voltage arc-over within the coil.

In the design of an ignition system, sufficient primary circuit resistance must be present to protect the distributor contacts from excessive arcing and burning. In some ignition systems, part of this resistance may take the form of a separate resistor or a calibrated resistance wire connected between the ignition switch and the coil primary terminal. Since the value of this resistor along with the resistances of the other components in the entire primary circuit affects the coil performance at higher engine speeds, a 12-volt coil used on a 6-volt system without the external resistor, will not provide equal

performance results. In other words, a 12-volt coil without the resistor is not necessarily a 6-volt coil.

During cranking, the external resistance on most applications is by-passed to provide full battery voltage to the coil for improved performance and easier starting. The by-pass wire may be connected to an "R" terminal on the cranking motor solenoid which contacts the contact disk during cranking, or to a separate terminal on the ignition switch, as shown in the previous section. The higher currents during cranking are not sufficient to cause distributor contact deterioration because of the short periods of time in the life of contacts spent during cranking. Also, the lowered battery voltage during cranking causes a lower primary current, so the resistor by-pass feature is an offsetting factor. By-passing the resistor with the engine operating will cause very rapid failure of the distributor contacts.

### Spark Plugs

The spark plug (Fig. 10i) consists of a metal shell in which is fastened a porcelain insulator and an electrode extending through the center of the insulator. The metal shell has a short electrode attached to one side and bent in toward the center electrode. There are threads on the metal shell that allow it to be screwed into a tapped hole in the cylinder head. The two electrodes are of special heavy wire, and there is a specified gap between them. The electric spark jumps this gap to ignite the air-fuel mixture in the combustion chamber, passing from the center, or insulated, electrode. The seals between the metal base, porcelain, and center electrode, as well as the porcelain itself, must be able to withstand the high pressure and temperature created in the combustion chamber during the power stroke.

Some spark plugs have been supplied with a built-in resistor which forms part of the center electrode. The purpose of this resistor is to reduce radio and television interference from the ignition system as well as to reduce spark-plug-electrode erosion caused by excessively long sparking. We have been talking of the high-voltage surge from the ignition-coil secondary as though it were a single powerful surge that almost instantly caused the spark to jump across the spark plug gap. Actually, the action is more complex than that. There may be a whole series of preliminary surges before a full-fledged spark forms. At the end of the sparking cycle the spark may be quenched and may reform several times. All this takes place in only a few ten-thousandths of a second. The effect is that the ignition wiring acts like a radio transmitting antenna; the surges of high voltage send out impulses that causes radio and television interference. However, the resistors in the spark plugs tend to concentrate the surges in each sparking cycle, reduce their number, and thus reduce the interference and also the erosive effect on the plug electrodes.

### Heat Range System

The "heat range" of a spark plug is determined primarily by the length of the lower insulator. The

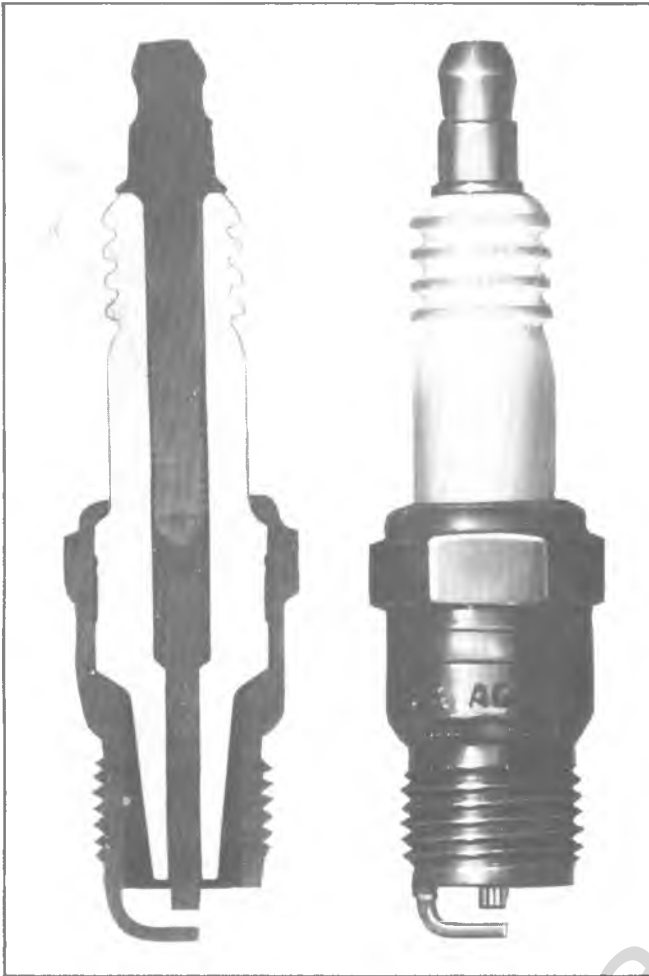

Fig. 10i—Cross-Section of Spark Plug

longer this is, the hotter the plug will operate; the shorter it is, the cooler the plug will operate (Fig. 11i).

Spark plugs, to give good performance in a particular engine, must operate within a certain temperature range (neither too hot nor too cool). If the spark plug remains too cool, oil, soot, and carbon compounds will deposit on the insulator causing fouling and missing. If the plug runs too hot, electrodes will wear rapidly, and under extreme conditions, premature ignition (pre-ignition) of the fuel mixture may result.

Frequently, the wrong type of spark plugs, one with an improper heat range for the engine, may have been installed when replacing spark plugs originally fitted by the engine manufacturer and such misapplication may lead to poor performance. The heat range system makes it possible to select the type of spark plug that will operate within the correct temperature range for each specific engine.

Where abnormal operating conditions cause chronic carbon or oil fouling of the plugs, the use of a type one number higher (a "hotter" type) than recommended will generally remedy the trouble; and by the same formula, where chronic pre-ignition or rapid electrode wear is

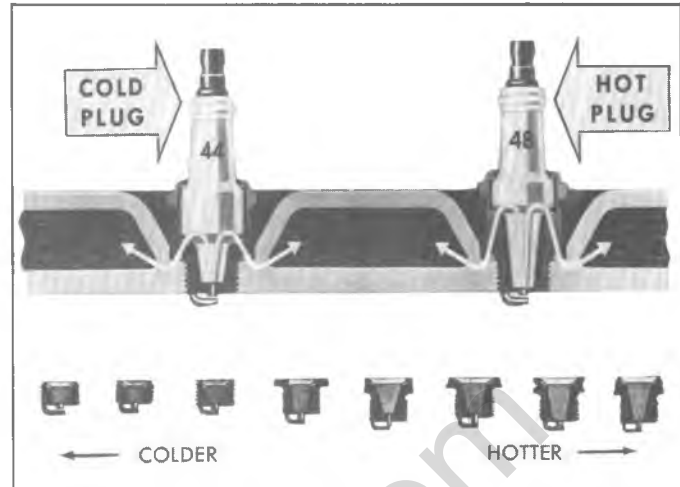

Fig. 11i—Spark Plug Heat Range System

experienced, a type with one number lower (a "cooler" type) will generally be found satisfactory.

The last digit of the type number indicates the heat range position of the plug in the heat range system. Read the numbers as you would a thermometer--the higher the last digit, the "hotter" the spark plug will operate in the engine; the lower the last digit, the "cooler" the spark plug will operate.

#### Spark Plug Reach and Threads

Spark plugs are manufactured in a number of thread sizes and "reaches." Reach is the distance from the gasket seat to the end of the shell. Spark Plugs have a type number on the insulator which designates plug thread size as well as the relative position in the heat range system as previously explained.

#### Secondary Ignition Cables

The secondary wiring consists of the high tension cables connected between the distributor cap, the spark plugs, and the high tension terminal of the ignition coil. These cables carry the high voltage surges to the spark plugs and are heavily insulated to contain the high voltages. The cables are neoprene jacketed and have a multiple cloth thread core impregnated with a graphite solution to give the correct conductivity and proper resistance for suppression of radio and television interference.

#### Ignition Switch

The electrical switching portion of the assembly is separate from the key and lock cylinder. However, both are synchronized and work in conjunction with each other through the action of the actuator rod assembly. For a complete explanation of the key and lock cylinder, and the actuator rod assembly, refer to the Steering section of this manual.

The ignition switch is key operated through the actuator rod assembly to close the ignition primary circuit and to energize the starting motor solenoid for cranking. The ignition switch has five positions: OFF,

LOCK, ACCESSORY, RUN and START. OFF is the center position of the key-lock cylinder, and LOCK is the next position to the left. ACCESSORY is located one more detent to the left of LOCK. Turning the key to the right of the OFF position until spring pressure is felt will put the ignition switch in the RUN position, and when turned fully to the right against spring pressure, the switch will be in the START position.

In the RUN position, the ignition primary circuit is activated through a resistance wire. The ignition resistor wire is used in the ignition running circuit to reduce the voltage to the ignition coil. The resistor wire is bypassed when the engine is being started. The purpose of this is to compensate for the drop in voltage which occurs as the result of the heavy drain on the battery during starting, and to provide a hotter spark for starting.

All ignition switches have five terminals which are connected in different combinations for each of the three operating positions. A brass plate, inside the switch, has three contacts which connect these terminals. Figure 12i shows the positions of the contacts in all positions as viewed from the key side of the switch. There is also a ground pin in the switch which contacts the "ground" terminal when the ignition switch is in the START position. This pin contacts the IGN. terminal when in the OFF position.

#### Ignition Start and Run Circuit

The ignition switch is fed from a junction at the horn relay to the BAT. terminal of the switch. When the ignition switch is in the OFF position, no current flows through the switch. When the ignition switch is turned to the ACC. position, the BAT. terminal is connected to the ACC. terminal. This permits operation of accessories when the engine is not running.

When the ignition switch is turned to the START

position, the BAT. terminal is connected to the SOL. and IGN. terminals. When the clutch or automatic transmission neutral start switches are closed, current flows to the starter solenoid. This energizes the solenoid windings. The solenoid has two sets of windings: a "pull-in" winding and a "hold-in" winding. Both windings are used to create the magnetic field to actuate the the solenoid plunger and move the starter pinion into engagement with the flywheel. As the solenoid plunger reaches the end of its travel, it closes a switch which connects battery voltage to the starter motor. With battery voltage applied to both terminals of the "pull-in" windings, the "pull-in" winding is no longer energized, so that only the "hold-in" winding keeps the starter solenoid engaged.

During cranking, current is directed from the battery through the brass disc in the starter solenoid housing to the "B" terminal on the solenoid and then to the ignition coil, bypassing the ignition resistor wire.

NOTE: The instrument panel warning lights are fed from the ignition terminal of the ignition switch and have battery voltage applied to them when the ignition switch is in the START and RUN position. These circuits are explained in the Chassis Electrical Section.

When the ignition switch is released from the START to the RUN position, the IGN. terminal is still connected to the BAT. terminal, but the solenoid is no longer energized and so the feed for the coil from the IGN. terminal on the ignition switch, through the ignition resistor wire and to the coil, dropping the battery voltage at the coil to approximately nine volts. With the ignition switch in the RUN position, the BAT. terminal is connected to the IGN. terminal and the ACC. terminal. This permits operation of all accessories and the ignition system.

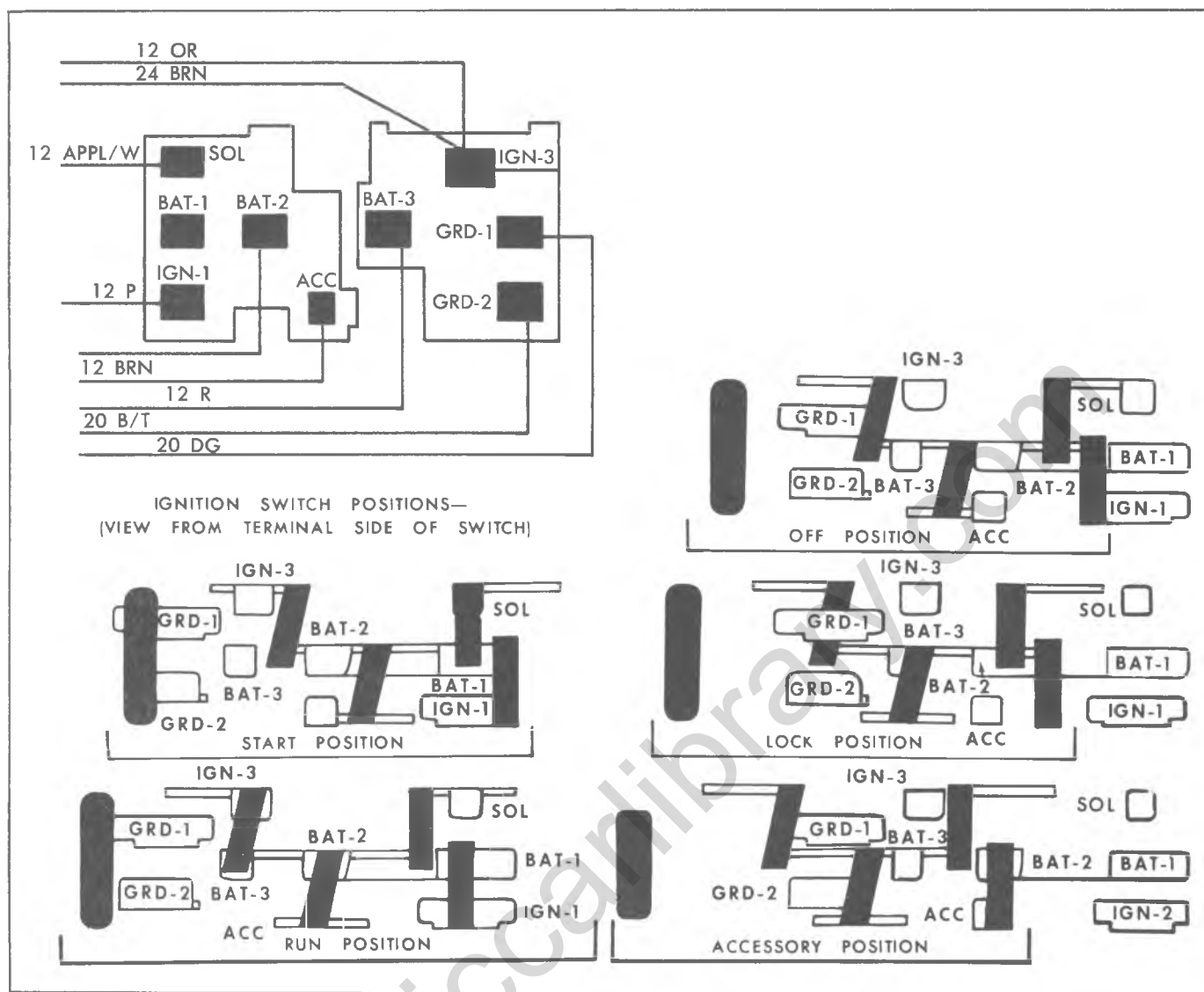

Fig. 12i—Ignition Switch Circuit

## ADJUSTMENTS AND REPAIRS

### Distributor Contact Points

#### Cleaning

Dirty contact points should be dressed with a few strokes of a clean, fine-cut contact file. The file should not be used for other metals and should not be allowed to become greasy or dirty. Never use emery cloth to clean contact points. Contact surfaces, after considerable use, may not appear bright and smooth, but this is not necessarily an indication that they are not functioning satisfactorily. Do not attempt to remove all roughness nor dress the point surfaces down smooth; merely remove scale or dirt.

Badly burned or pitted contact points should be replaced and the cause of trouble determined so it can be

eliminated. High resistance or loose connections in the condenser circuit, oil or foreign materials on the contact surfaces, improper point adjustment or high voltages may cause oxidized contact points. Check for these conditions where burned contacts are experienced. An out-of-balance condition in the ignition system, often the result of too much or too little condenser capacity, is indicated where point pitting is encountered.

#### Replacement

##### *Six Cylinder Engine Distributor*

1. Release distributor cap hold-down screws, remove cap and place it out of work area.
2. Remove rotor. On Van models, also remove dust shield.

3. Pull primary and condenser lead wires from contact point quick disconnect terminal (fig. 13i).
4. Remove contact set attaching screw, lift contact point set from breaker plate.
5. Clean breaker plate of oil smudge and dirt.
6. Place new contact point assembly in position on breaker plate, install attaching screw.

NOTE: Pilot on contact set must engage matching hole in breaker plate.

7. Connect primary and condenser lead wires to quick disconnect terminal on contact point set.

NOTE: The contact point pressure must fall within specified limits. Weak tension will cause chatter resulting in arcing and burning of the points and an ignition miss at high speed, while excessive tension will cause undue wear of the contact points, cam and rubbing block. Breaker arm spring tension should be 19-23 ounces. The contact point pressure can be checked with a spring gauge.

8. Set point opening (.019" for new points).
9. Rotate cam lubricator 180 degrees at 12,000 mile intervals. Replace every 24,000 miles.
10. On Van models, install dust shield. Reinstall rotor, position and lock distributor cap to housing.
11. Start engine and test dwell and ignition timing.

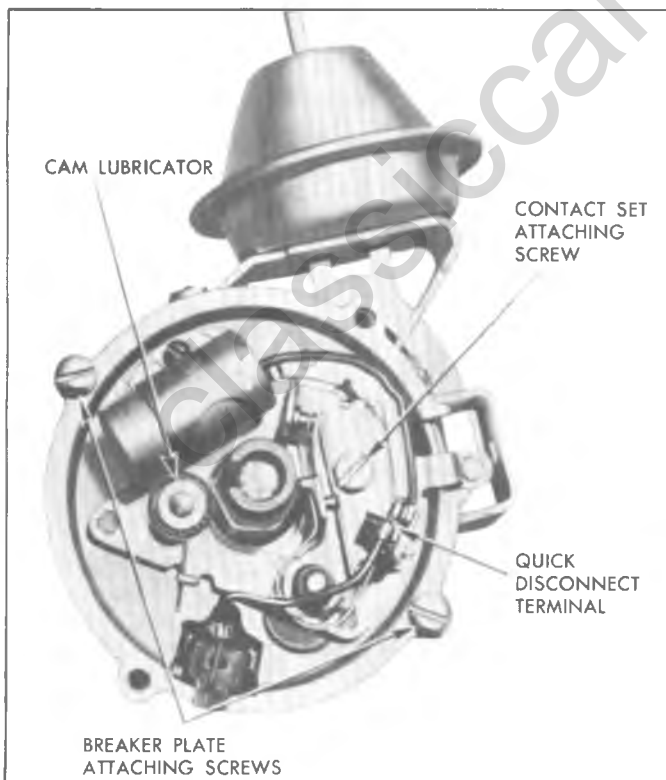

Fig. 13i—Breaker Plate and Attaching Parts

### Eight Cylinder Engine Distributor

NOTE: The contact point set and condenser is replaced as one complete assembly and only dwell angle requires adjustment after replacement. Breaker lever spring tension and point alignment are factory set.

1. Remove the distributor cap by placing a screwdriver in the slot head of the latch, press down and rotate 1/4 turn in either direction.
2. Remove rotor attaching screws and rotor.
3. Loosen the two attaching screws which hold the base of the contact set assembly in place and slide set from breakerplate.
4. Disconnect the primary lead from the nylon insulated terminal (fig. 14i).
5. Reverse Steps 2, 3 and 4 to install new contact point and condenser set.

**CAUTION:** Install the primary lead as shown in Figure 14i. Improper installation will cause lead interference between the cap, weight base and breaker advance plate.

6. The cam lubricator should be rotated at 12,000 mile intervals and replaced at 24,000 mile intervals.
7. Start engine and check point dwell and ignition timing.

### Setting Dwell Angle

### Six Cylinder Engine Distributor

The point opening of new points can be checked with a feeler gauge, but the use of a feeler gauge on rough or uncleaned used points is not recommended since accurate mechanical gauging cannot be done on such points (fig. 15i).

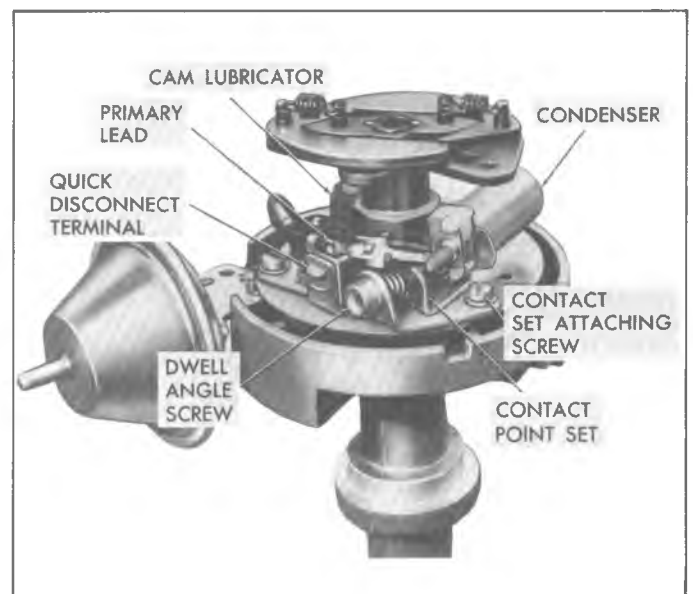

Fig. 14i—Distributor Lead Arrangements

## 6Y-36 ENGINE ELECTRICAL

The point opening of new points can be checked with a feeler gauge, but the use of a feeler gauge on rough or uncleaned used points is not recommended since accurate mechanical gauging cannot be done on such points (fig. 15i).

Contact points must be set to the proper opening. Points set too close may tend to burn and pit rapidly. Points with excessive separation tend to cause a weak spark at high speed. Proper point setting for all models are:

.019" for new points

.016" for used points

New points must be set to the larger opening as the rubbing block will wear down slightly while seating to the cam. Contact points should be cleaned before adjusting if they have been in service.

To adjust contact point opening:

1. If necessary, align points (fig. 16i) by bending the fixed contact support. Do not bend the breaker lever. Do not attempt to align used points; replace them where serious misalignment is observed. Use an aligning tool if available.
2. Turn or crank the distributor shaft until the breaker arm rubbing block is on the high point of the cam lobe. This will provide maximum point opening.
3. Loosen the contact support lock screw.
4. Use a screw driver (fig. 17i) to move the point support to obtain .019" opening for new points and a .016" opening for used points.
5. Tighten the contact support lock screw and recheck the point opening.

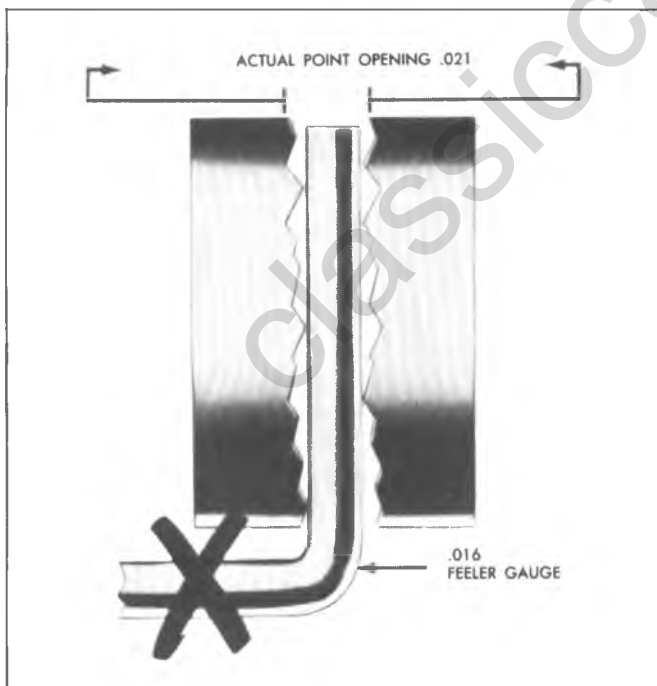

Fig. 15i—Inaccurate Gauging of Rough Points

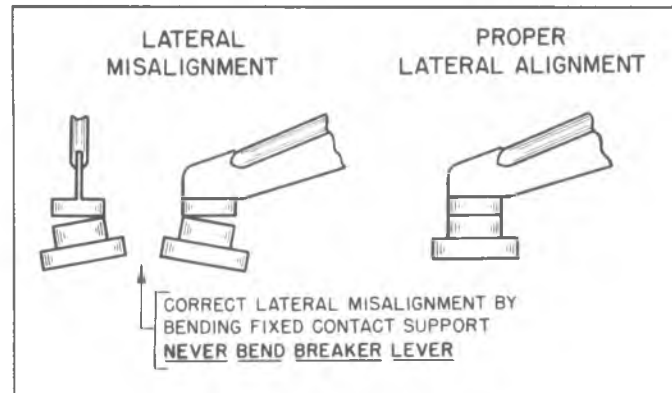

Fig. 16i—Alignment of Points

6. After checking and adjusting the contact point opening to specifications, the cam angle or dwell should be checked with a dwell angle meter if such equipment is available (see Specifications for proper dwell angle). If the cam angle is less than the specified minimum, check for defective or misaligned contact points or worn distributor cam lobes. The variation in cam angle readings between idle speed and 1750 engine rpm should not exceed 3°. Excessive variation in this speed range indicates wear in the distributor.

NOTE: Cam angle readings taken at speeds above 1750 engine rpm may prove unreliable on some cam angle meters.

### *Eight Cylinder Engine Distributor*

#### *On the Vehicle*

With the engine running at idle and operating

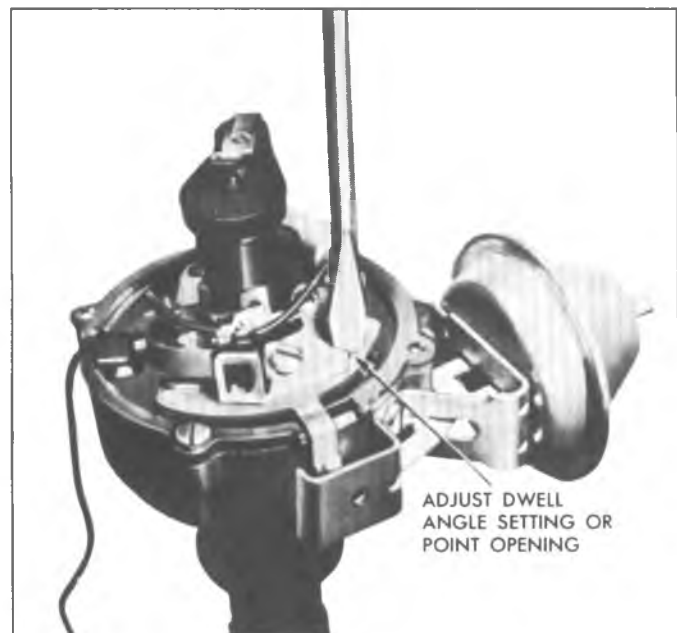

Fig. 17i—Setting Point Opening



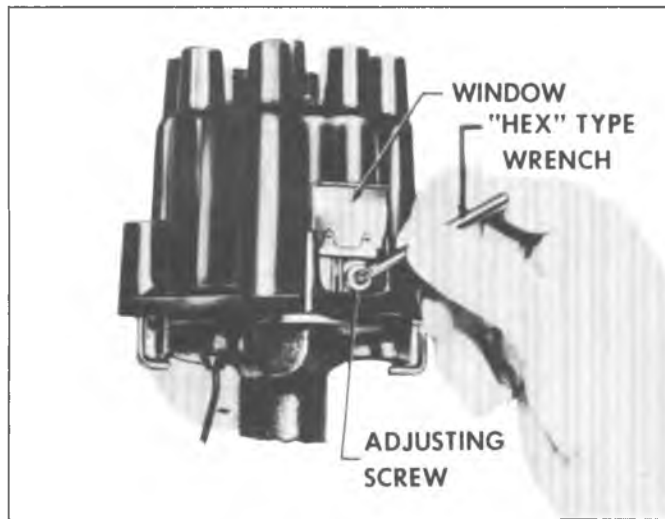

Fig. 18i—Adjusting Dwell Angle

temperatures normalized, the dwell is adjusted by first raising the window provided in the cap and inserting a "HEX" type wrench into the adjusting screw head. (fig. 18i).

1. Preferred Method - Turn the adjusting screw until the specified dwell angle is obtained as measured in degrees ( $29^{\circ}$  to  $31^{\circ}$ ,  $30^{\circ}$  preferred) by a dwell angle meter.
2. Alternate Method - Turn adjusting screw in (clockwise) until the engine begins to misfire, then turn screw  $1/2$  turn in the opposite direction (counterclockwise). This will give the approximate dwell angle required. (Use only when meter is not available.)

#### Off the Vehicle

1. Distributor Test Method:
  - a. With the distributor mounted on a distributor testing machine, connect the dwell meter to the distributor primary lead.
  - b. Turn the adjusting screw (fig. 18i) to set the dwell angle to 30 degrees.
2. Test Light Method:
  - a. With the distributor mounted in a vise, connect a testing lamp to the primary lead.
  - b. Rotate the shaft until one of the circuit breaker cam lobes is under the center of the rubbing block of the breaker lever.
  - c. Turn the adjusting screw clockwise (fig. 18i) until the lamp lights, then give the wrench  $1/2$  turn in the opposite direction (counter-clockwise) to obtain the proper dwell angle.

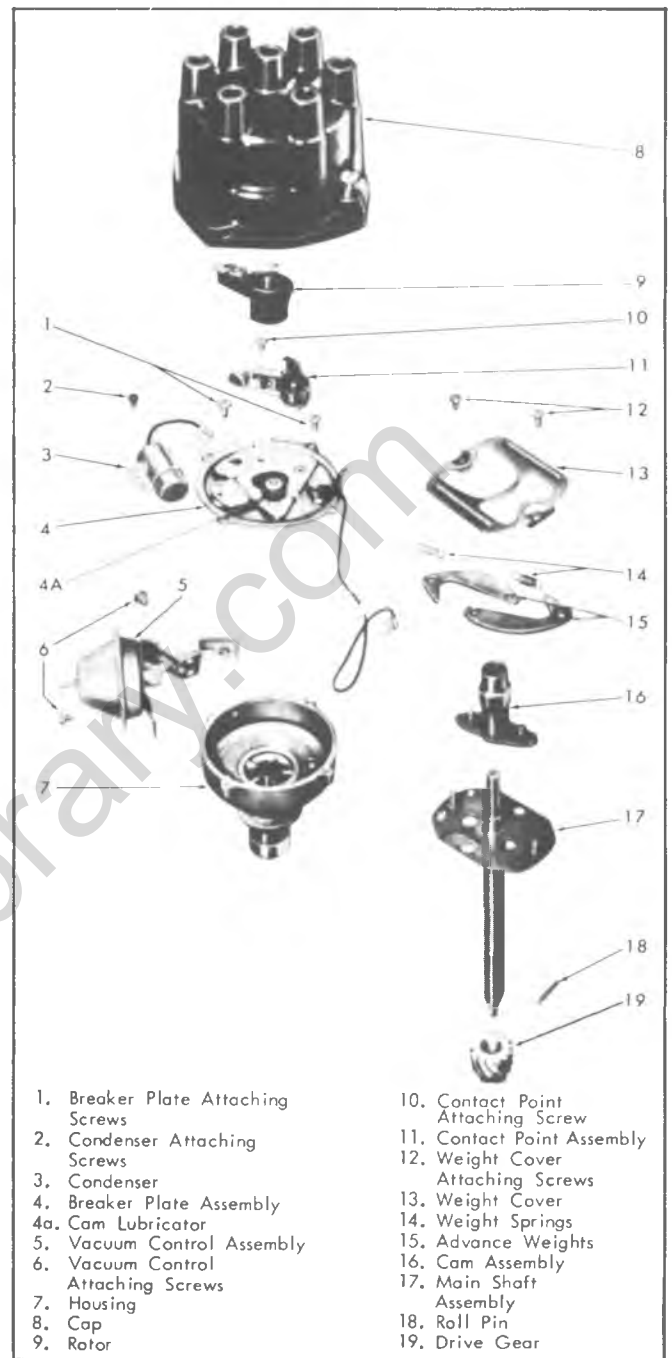

Fig. 19i—L-6 Distributor - Exploded View

### Distributor Condenser

#### Performance Diagnosis

The following four factors affect condenser performance and, each factor must be considered in making any condenser test.

1. Breakdown - A failure of the insulating material. A direct short between the metallic elements of the condenser. This prevents any condenser action.
2. Low Insulating Resistance (Leakage) - Low insulation resistance prevents the condenser from

holding a charge. All condensers are subject to leakage which, up to a certain limit, is not objectionable.

3. High Series Resistance - Excessive resistance in the condenser circuit due to broken strands in the condenser lead or to a defective connection. This will cause burned points and ignition failure upon initial starts and at high speeds.
4. Capacity - Capacity is determined by the area of the metallic elements and the insulating and impregnating materials.

For a complete check of the condenser, use a tester which will check for all of the above conditions. Follow the instructions given by the manufacturer of the test equipment. Condenser capacity should be 18-23 microfarads.

### Replacement

#### Six Cylinder Engine Distributor (Fig. 13i)

1. Release distributor cap hold-down screws, remove cap and place it out of the work area.
2. Remove rotor. On Van models, also remove dust shield.
3. Disconnect condenser lead wire from contact point quick-disconnect terminal.
4. Remove condenser attaching screw, lift condenser from breaker plate and wipe breaker plate clean.
5. Install new condenser using reverse of procedure outlined above.

### Distributor

#### Removal

1. Release the distributor cap hold-down screws, remove the cap and place it clear of the work area.

NOTE: If necessary, remove secondary leads from the distributor cap after first marking the cap tower for the lead to No. 1 cylinder. This will aid in the reinstallation of leads in the cap.

2. Disconnect the distributor primary lead from the coil terminal.
3. Scribe a realignment mark on the distributor bowl and engine in line with the rotor segment.
4. Disconnect vacuum line to distributor. Remove the distributor holddown bolt and clamp and remove the distributor from the engine. Note position of vacuum advance mechanism relative to the engine.

**CAUTION:** Avoid rotating the engine with the distributor removed as the ignition timing will be upset.

#### Disassembly

It is advisable to place the distributor in a distributor

testing machine or synchroscope prior to disassembly. When mounting distributors for tests, first secure the gear in the test drive mechanism, then push the distributor housing downward toward the gear to take up any end play between the gear and the housing.

Test the distributor for variation of spark, correct centrifugal and vacuum advance and condition of contacts. This test will give valuable information on distributor condition and indicate parts replacement which may be necessary. Check the area on the breaker plate just beneath the contact points. A smudgy line indicates that oil or crankcase vapors have been present between the points.

#### Six Cylinder Engines (Fig. 19i)

1. Remove the rotor, on Van models also remove dust shield.
2. Remove the vacuum control assembly retaining screws, detach the unit from the distributor housing.
3. Disconnect the primary and condenser leads from the contact point quick disconnect terminal, remove the contact point set attaching screw, condenser attaching screw. Remove the point set and condenser from the breaker plate.
4. Remove the breaker plate attaching screws, remove the breaker plate from the distributor housing.  
NOTE: Do not disassemble breaker plate any further.
5. Remove the roll pin retaining the driven gear to the mainshaft, slide the gear from the shaft.
6. Slide the cam and mainshaft from the distributor housing.
7. Remove the weight cover and stop plate screws, remove the cover, weight springs, weights and slide cam assembly from the mainshaft.

#### V-8 Engines (Fig. 20i)

1. Remove the rotor.
2. Remove both weight springs and advance weights.
3. Remove roll pin retaining driven gear to distributor shaft, slide the gear and spacers from the shaft.
4. Before sliding the distributor shaft from the housing, check for and remove any burrs on the shaft. This will prevent damage to the seals and bushing still positioned in the housing.
5. Slide the distributor mainshaft and cam-weight base assembly from the housing.
6. Remove vacuum advance mechanism retaining screws, remove the vacuum advance assembly.
7. Remove the spring retainer, remove the breaker plate assembly from the distributor housing. Remove the contact points and condenser from the breaker plate. Remove the felt washer and plastic seal located beneath the breaker plate.

**Cleaning and Inspection**

1. Wash all parts in cleaning solvent except cap, rotor, condenser, breaker plate assembly and vacuum control unit. Degreasing compounds may damage insulation of these parts or saturate the lubricating felt in the case of the breaker plate assembly.
2. Inspect the breaker plate assembly for damage or wear and replace if necessary.
3. Inspect the shaft for wear and check its fit in the bushings in the distributor body. If the shaft or bushings are worn, the parts should be replaced.
4. Mount the shaft in "V" blocks and check the shaft alignment with a dial gauge. The run-out should not exceed .002".
5. Inspect the advance weights for wear or burrs and free fit on their pivot pins.
6. Inspect the cam for wear or roughness. Then check its fit on the end of the shaft. It should be absolutely free without any roughness.
7. Inspect the condition of the distributor points. Points should be cleaned and badly pitted points should be replaced. (See Distributor Contact Points.)
8. Test the condenser for series resistance, microfarad capacity (.18 to .23) and leakage or breakdown, following the instructions given by the manufacturer of the test equipment used.
9. Inspect the distributor cap and spark plug wires for damage and replace if necessary.

**Assembly****Six Cylinder Engine (Fig. 19i)**

1. Replace cam assembly to mainshaft.

NOTE: Lubricate top end of shaft with Delco cam and ball bearing grease or equivalent prior to replacing.

2. Install governor weights on their pivot pins, replace weight springs. Install weight cover and stop plate.
3. Lubricate mainshaft and install it in distributor housing.
4. Install distributor driven gear to mainshaft and insert attaching roll pin. Check to see that shaft turns freely.
5. Install breaker plate assembly in the distributor body and attach retaining screws.
6. Attach condenser and contact point set.

NOTE: Contact point set pilot must engage matching hole in breaker plate. Connect primary and condenser leads (as applicable) to contact set quick-disconnect terminal.

7. Attach vacuum control assembly to distributor housing.
8. Check and adjust contact point opening.
9. On Van models, install dust shield, then install rotor.

**V-8 Engine—(Fig. 20i)**

1. Fill housing lubricating cavity, press in new plastic seal and install felt washer.
  2. Replace the vacuum advance unit, install the breaker plate in housing and install the spring retainer on the upper bushing.
  3. Lubricate and slide weight cam over mainshaft and install weights and spring (fig. 22i).
  4. Insert mainshaft into housing, indexing it with drive gear and washers.
  5. Slide distributor drive gear shims and gear over shaft and install new pin. Tap new pin through gear and mainshaft. Check shaft for free rotation.
  6. Install contact point and condenser assembly to breaker plate. Connect primary lead as shown in Figure 14i.
- NOTE: Contact point spring tension is factory set above specifications to assure ease of final adjustment. Correct tension is 19-23 oz. Hi Performance is 28-32 oz.
7. Install rotor to cam assembly, indexing round and square pilot holes.

**Installation—Engine Not Disturbed**

1. Turn the rotor about 1/8 turn in a clockwise direction past the mark previously placed on the distributor housing to locate rotor.
2. Push the distributor down into position in the block with the housing in a normal "installed" position (fig. 21i).

NOTE: It may be necessary to move rotor slightly to start gear into mesh with camshaft gear, but rotor should line up with the mark when distributor is down in place.

3. Tighten the distributor clamp bolt snugly and connect vacuum line. Connect primary wire to coil terminal and install cap. Also install spark plug and high tension wires if removed.

NOTE: It is important that the spark plug wires be installed in their proper location in the supports and also in the cap.

4. Time ignition as previously described under Tune Up in Section 6.

**Installation—Engine Disturbed**

1. Locate No. 1 piston in firing position by either of

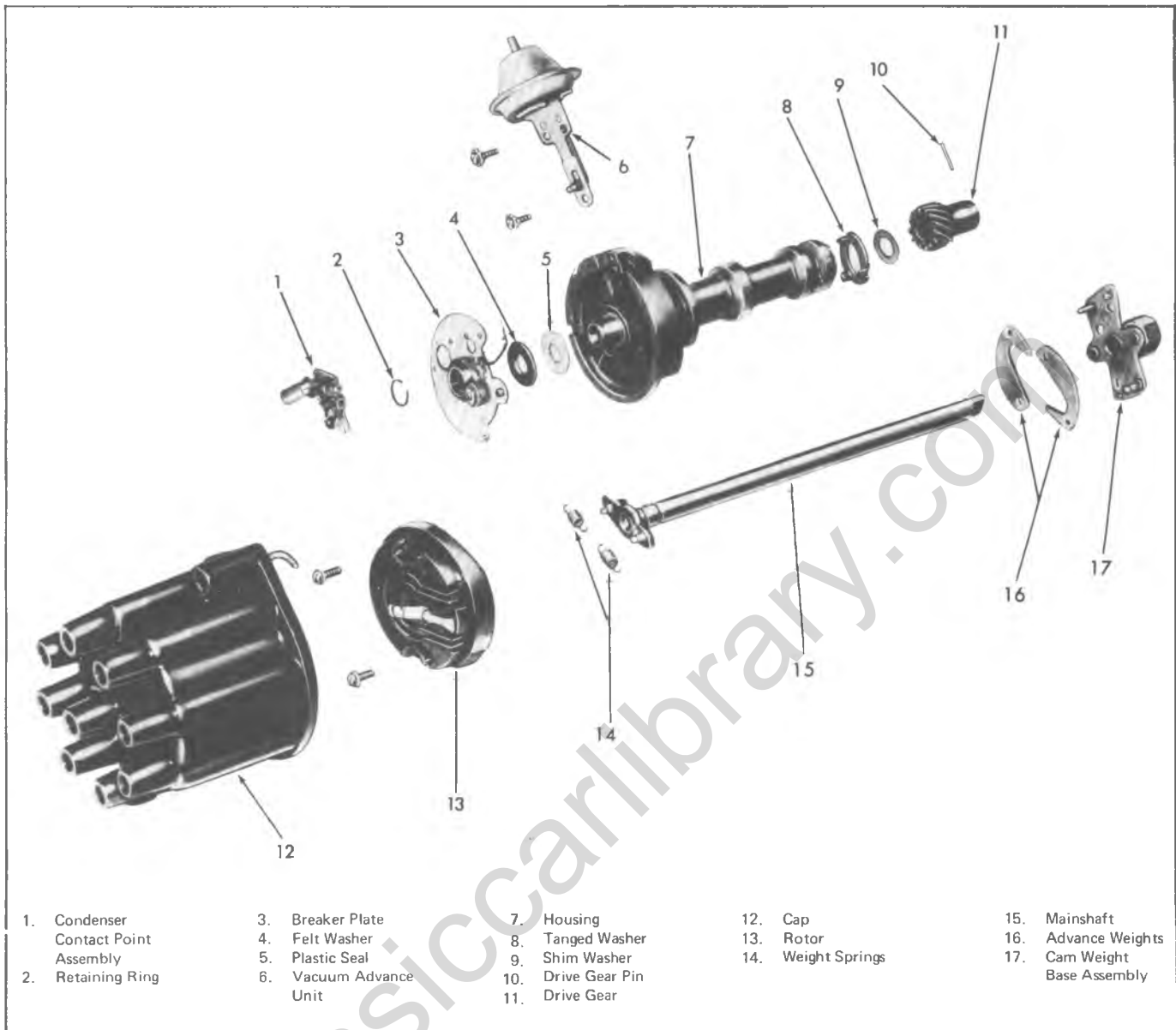

Fig. 20i-V-8 Distributor (Typical) - Exploded View

two methods described below.

- a. Remove No. 1 spark plug and, with finger on plug hole, crank engine until compression is felt in the No. 1 cylinder. Continue cranking until timing mark on crankshaft pulley lines up with timing tab attached to engine front cover.
  - b. Remove rocker cover (left bank on V-8 engines) and crank engine until No. 1 intake valve closes and continue to crank slowly about 1/3 turn until timing mark on pulley lines up with timing tab.
2. Position distributor to opening in block in normal installed attitude, noting position of vacuum control unit.

**NOTE:** On Mark IV engines the distributor may be installed with the distributor cap in place by using the punch mark on the distributor drive gear for alignment instead of the rotor as follows: Align the punch mark on the gear, which represents the centerline of the rotor, approximately 2° clockwise from the distributor cap #1 terminal, then rotate the distributor body counterclockwise slightly (1/8 turn) so that the distributor points just break open (.002 maximum). Secure the distributor clamp and proceed with steps 3 thru 7 as required.

3. Position rotor to point toward front of engine (with distributor housing held in installed attitude), then

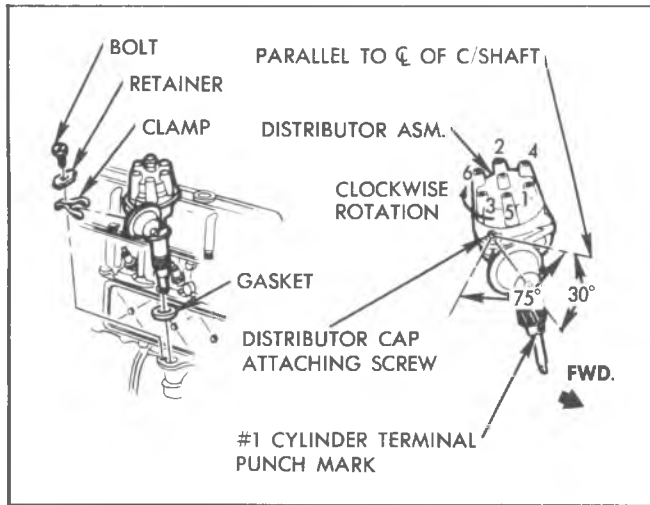

Fig. 21i—Six Cylinder Engine Distributor Installation

turn rotor counter-clockwise approximately 1/8 turn more toward left cylinder bank and push distributor down to engine camshaft. It may be necessary to rotate rotor slightly until camshaft engagement is felt.

4. While pressing firmly down on distributor housing, kick starter over a few times to make sure oil pump shaft is engaged. Install hold-down clamp and bolt and snug up bolt.
5. Turn distributor body slightly until points just open and tighten distributor clamp bolt.
6. Place distributor cap in position and check to see that rotor lines up with terminal for No. 1 spark plug.
7. Install cap, check all high tension wire connections and connect spark plug wires if they have been removed.
8. Connect vacuum line to distributor and distributor primary wire to coil terminal.
9. Start engine and set timing as described under Tune Up in Section 6.

### Distributor Off-Engine Test

The distributor's centrifugal and vacuum advance can be checked in a distributor testing machine or synchroscope designed to accommodate the distributor. However, since this involves removing the distributor from the engine, this test may be postponed until other system checks have been made.

### Coil Replacement

1. Disconnect ignition switch and distributor leads from terminals on coil.
2. Pull high tension wire from center terminal of coil.
3. Remove the two coil support mounting bolts or loosen friction clamp screw and remove coil.
4. Place new coil in position and install attaching bolts

or tighten clamp screw.

5. Place high tension lead securely in center terminal of coil and connect ignition switch and distributor primary leads to terminals on coil.
6. Start engine and check coil operation.

## Spark Plug and Wire Service

### Removal and Inspection

1. To disconnect wires, pull only on the boot. Pulling on the wire might cause separation of the core of the wire. Remove spark plugs using a 5/8" deep socket on the 5/8" hex tapered plugs. Use care in this operation to avoid cracking spark plug insulators.
2. Carefully inspect the insulator and electrodes of all spark plugs. Replace any spark plug which has a cracked or broken insulator. If the insulator is worn away around the center electrode, or the electrodes are burned or worn, the spark plug is worn out and should be discarded. Spark plugs which are in good condition except for carbon or oxide deposits should be thoroughly cleaned and adjusted.
3. The spark plug wires are of a special resistance type. The core is carbon-impregnated linen. This wire is designed to eliminate radio and television interference radiation, but is also superior in resistance to cross fire. The resistance type wire, however, is more easily damaged than copper core wire. For this reason care must be taken that the spark plug wires are removed by pulling on the spark plug boots rather than on the wire insulation. Also, when it is necessary to replace a spark plug boot, the old boot should be carefully cut from the wire and a small amount of silicone lubricant used to aid in installing the new boot. If the wire is stretched, the core may be broken with no evidence of damage on the outer insulation. The terminal may also pull off the wire. If the core is broken, it will cause missing. In the case of wire damage, it is necessary to replace the complete wire assembly as a satisfactory repair cannot be made.
4. Wipe ignition wires with cloth moistened with kerosene, and wipe dry. Carefully bend wires to check for brittle, cracked, or loose insulation. Defective insulation will permit missing or cross-firing of engine, therefore defective wires should be replaced.
5. If the wires are in good condition, clean any terminals that are corroded and replace any terminals that are broken or distorted. Replace any broken or deteriorated cable nipples or spark plug boots.

### Spark Plug Cleaning

Spark plugs which have carbon or oxide deposits should be cleaned in a blast type spark plug cleaner. Scraping with a pointed tool will not properly remove the deposits and may damage the insulator. If spark plugs have a wet or oily deposit dip them in a degreasing solvent and then dry thoroughly with dry compressed air. Oily plugs will cause the cleaning compound to pack in the shell. Carefully follow the instructions of the manufacturer of the cleaner being used, cleaning each plug until the interior of shell and the entire insulator are clean; however, avoid excessive blasting.

Examine interior of plug in good light. Remove any cleaning compound with compressed air. If traces of carbon oxide remain in plug, finish the cleaning with a light blasting operation. Clean firing surfaces of center and side electrodes with several strokes of a fine file.

When spark plugs have been thoroughly cleaned, carefully inspect for cracks or other defects which may not have been visible before cleaning.

### Adjusting Spark Plug Gap (Fig. 22i)

Use round wire feeler gages to check the gap between spark plug electrodes of used plugs. Flat feeler gages will not give a correct measurement if the electrodes are worn. Adjust gap by bending the side electrodes only. Adjust gaps to specifications. Setting spark plug gap to other than specification to effect changes in engine performance is not recommended.

### Installation of Spark Plugs

When installing spark plugs, make sure that all surfaces on plugs and in cylinder heads are clean. When

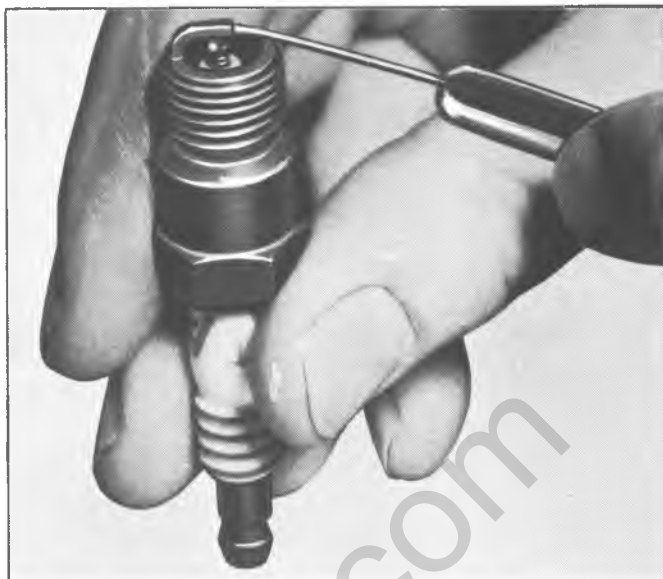

Fig. 22i—Checking Spark Plug Gap

installing the 5/8" hex tapered seat spark plugs, tighten to 15 lb. ft., using a 5/8" deep socket, an extension and a torque wrench.

**CAUTION:** *If tapered seat spark plugs are over-tightened, there is a possibility they can crack and be more difficult to remove at the next tune-up.*

### Installation of Spark Plug Wires

No. 1 spark plug wire is installed in the first distributor cap tower after the adjusting window, moving in the direction of rotation (V-8), or in the foremost tower (L-6). The other wires are then installed in a clockwise direction according to the firing order (figs. 23i).

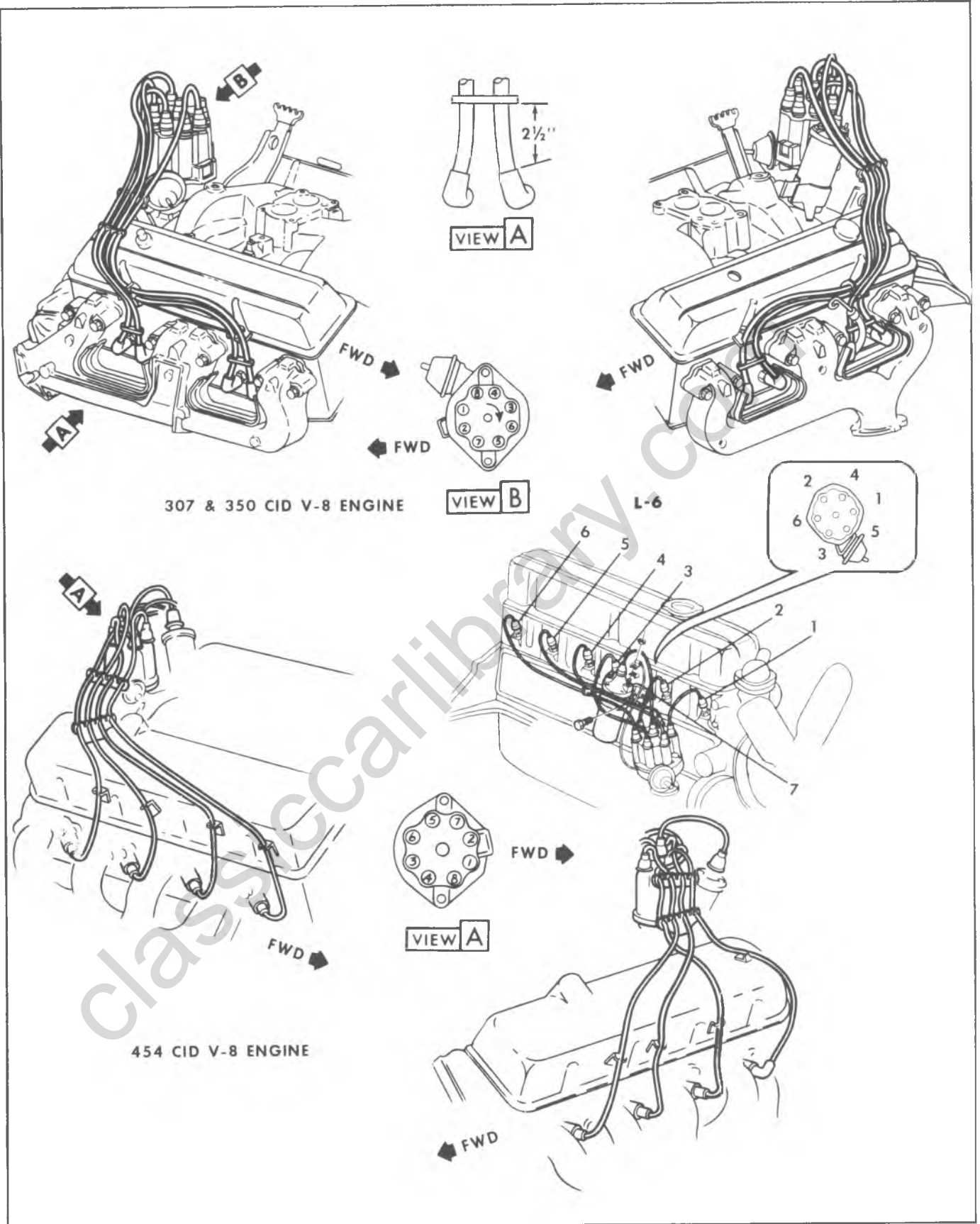

Fig. 23i—Spark Plug Wire Installation

## DIAGNOSIS

### IGNITION SYSTEM

#### A. Engine Will Not Start But Cranks O.K.

1. Disconnect a spark plug wire and hold 1/4" away from the engine block, then crank engine.
  - a. If strong spark is seen, check timing. Adjust as necessary. If timing is correct, trouble is not in ignition system.
  - b. If no spark or an intermittent spark is seen, reconnect plug wire and proceed to step 2.
2. Disconnect distributor cap-to-coil lead from coil and place screwdriver blade across coil tower to engine block and crank engine.
  - a. If strong spark is seen between coil tower and metal bar, check distributor cap and rotor for cracks or carbon tracking. Check lead between distributor and coil for broken or burned terminals or cracks in insulation. Replace defective parts.
  - b. If no spark or intermittent spark is seen, proceed to step 3.
3. Connect jumper wire from battery plus (+) terminal to coil plus (+) terminal. Place a screwdriver blade across coil tower to engine block and crank engine.
  - a. If strong spark is seen, remove jumper wire and check wiring connections and switches between battery plus (+) terminal and coil (+) terminal. Opens, high resistance or intermittent contact will require repair or replacement.
  - b. If no spark or intermittent spark is seen, remove jumper wire and proceed to step 4.
4. Disconnect distributor lead from coil minus (-) terminal and connect test light from coil minus (-) terminal to engine block. Turn ignition switch to crank position.
  - a. If lamp does not light, replace coil.
  - b. If lamp lights proceed to step 5.
5. Connect test light from battery plus (+) terminal to distributor lead which is still detached from the coil. If necessary, rotate distributor until points close.
  - a. If lamp lights, check condenser and points. Replace defective parts.
  - b. If lamp does not light, proceed to step 6.
6. Connect test lamp from battery plus (+) terminal to connection of distributor lead and contact points. Make sure points are closed.

- a. If lamp lights, replace distributor lead to coil.
  - b. If lamp does not light, proceed to step 7.
7. Connect test lamp from battery plus (+) terminal to screw holding points in place.
    - a. If lamp lights, replace points and check capacitor.
    - b. If lamp does not light, breaker plate or distributor is not grounded. Check plate-to-distributor ground wire or distributor-to-engine block connector.

#### B. Engine Starts But Will Not Continue to Run

1. Connect jumper wire from battery plus (+) terminal to ignition coil plus (+) terminal and start engine.
  - a. If engine does not continue to run, problem is not ignition.
  - b. If engine runs, proceed to step 2.
2. Remove jumper and disconnect leads from battery plus (+) terminal and coil (+) terminal. Connect ohmmeter and measure resistance between the ends of the leads just detached. Ignition switch should be in the run position.
  - a. If resistance exceeds 2.5 ohms, check wires and connections for loose or intermittent contact. Check by-pass resistor and ignition switch for opens.
  - b. If resistance is 1.0 to 2.5 ohms, check the output of the ignition coil.
  - c. If resistance is less than 1.0 ohm, replace shorted by-pass resistor and replace contact points.

#### C. Engine Runs Rough, Poor Power or Gas Mileage

1. Check all tune-up specifications (timing, dwell, carburetion, fouled plugs, etc.) If settings are improper, correct as required.
2. If settings are O.K. check both centrifugal and vacuum advance of distributor and correct with replacement parts, if necessary.
3. If distributor advance mechanisms are within specifications, check coil available voltage and plug required voltage.
  - a. High requirements or low availability of voltage will require a replacement of parts.
  - b. If coil and plugs are O.K., the problem is not in the ignition system.



## IGNITION COIL TEST

### A. Weak Coils

Most ignition coils that are replaced are classified as weak. Many coils rejected as weak actually test up to specifications and give normal performance. A coil that actually is weak will first effect engine performance when the ignition reserve is at a minimum. This may be in starting, low speed acceleration or top speed. Eventually the engine will fail to start.

High resistance connections in either the primary or secondary circuit wiring will react the same as a weak coil. Wide spark plug gaps, which require higher voltage than the coil can produce, put the coil under suspicion. High compression and lean carburetion increase the voltage requirements and lead to many needless coil changes. Leakage of high tension current through moisture on an unprotected coil terminal may produce carbon tracks which weaken the coil output voltage. For this reason the nipple on coil high tension terminal must be properly installed and in good condition.

When an ignition coil is suspected of being defective it should be tested as described below before being replaced.

### B. Testing Coil for Open and Grounded Circuits

Before using a coil test instrument, the coil should be tested for open and grounded circuits, using a 110-volt test lamp and test points.

1. Apply test points to both primary terminals of coil. If test lamp does not light, the primary circuit is open.
2. Apply one test point to the high tension terminal, and the other test point to one of the primary terminals. If secondary circuit is not open, the lamp will not light but tiny sparks will appear at test points when they are rubbed over terminals. If secondary circuit is open, no sparks will occur.
3. Apply one test point to a clean spot on the metal coil case and touch the other point to the primary and high tension terminals. If the lamp lights, or tiny sparks appear at the points of contact, the coil windings are grounded.
4. A coil with open or grounded windings must be replaced since internal repairs cannot be made. It is unnecessary to test such a coil with instruments. If windings are not open or grounded, a test for short circuits and other internal defects should be made with a reliable coil test instrument.

### C. Coil Test Instruments

Two general type of instruments are used in testing ignition coils. One type makes use of an open or protected spark gap, while the other reports the condition of the coil on a meter.

The spark gap type of tester should always be used comparatively, that is, the questionable coil should be

compared with a coil of same model that is known to be good. Both coils must be at the same temperature and identical test leads must be used.

Certain variables caused by altitude, atmosphere or spark gap electrode conditions are usually present in the spark gap type of test.

The meter type testers are usually designed to permit testing the coil without making any connection to the secondary terminal. This eliminates the variables usually present in the spark type of test and avoids the necessity for comparison with a good coil.

Some different makes and models of coil testers differ in their methods of use, as well as in the markings on meters, the instructions of the manufacturer must be carefully followed when using any coil tester. The instrument must be frequently checked to make certain that it is accurately calibrated.

Regardless of instrument or method used, the coil must be tested at normal operating temperature because internal defects often fail to show up on a cold test.

## DISTRIBUTOR CONDENSER TEST

When a condenser is suspected of being faulty it should be tested with a reliable condenser tester to determine whether it is actually the cause of ignition trouble. The condenser should be tested for (a) high series resistance (b) insufficient or excessive capacity (c) low insulation resistance.

A special condenser tester is required to make these tests. When using a condenser tester the instructions of the manufacturer must be carefully followed.

NOTE: The condenser must be at normal operating temperature when it is being tested.

### A. High Series Resistance

High series resistance in the condenser causes the condenser to be slow in taking the charge and, consequently, a higher than normal voltage is developed across the contact points when they first start to open. The higher voltage causes more disturbance at the contact points, which in turn causes more rapid wear and more tendency toward oxidized surfaces. The condition can become severe enough to cause complete failure of the ignition system. It would first show up during starting and low speed operation.

High series resistance may be caused by internal resistance in condenser or by resistance in the connections. Any defect caused by internal resistance should show up at low mileage since this does not change very much with time or use. The damaging changes are in the connections, in which looseness, corrosion, or broken strands may develop.

New condensers may have a series resistance as low as .05 ohm. Some condenser testers are set to reject condensers which have a resistance of .3 ohm; however,

test show that the resistance can go to .5 ohm before ignition performance is affected.

### B. Insufficient or Excessive Capacity

The condenser specified for use in the ignition system has a capacity of .18 to .23 microfarads.

If a condenser is used which does not have the specified capacity of .18 to .23 microfarads, excessive pitting of one contact point and a corresponding buildup of metal on the other contact point will result. A condenser having insufficient capacity will cause build-up of metal on the breaker arm (positive) point. A condenser having excessive capacity will cause build-up of metal on the contact support (negative) point.

In exceptional cases, pitting and metal buildup on contact points may be experienced even when condenser capacity is within the specified limits. In such cases the life of contact points will be improved by installing a condenser of high-limit capacity if metal build-up is on breaker arm point, or a condenser of low-limit capacity if metal build-up is on contact support point. There is usually sufficient variation in the capacities of stock condensers to permit selection of a high or low limit condenser by testing the available stock.

### C. Low Insulation Resistance

A weak or leaking condenser is usually one that has absorbed water so that the insulation resistance of the winding is lowered to the extent that the condenser will not hold a charge satisfactorily. A condenser with low insulation resistance will drain sufficient energy from the ignition system to lower the secondary voltage seriously. The condenser specified for use in the ignition system is sealed to prevent absorption of water, and no other type should be used.

A leaky condenser usually does not affect engine performance except when hot. It is unlikely that a condenser with low insulation resistance would cause missing at low or medium speeds under conditions where the condenser does not get hot. A condenser that has low enough resistance to affect engine performance when cold would probably be indicated as broken down on most condenser testers.

Condenser testers equipped to check condensers for low insulation resistance usually give a reading megohms, a megohm being one million ohms. The scale is marked to indicate whether the condenser is good or bad.

When testing a condenser for low insulation resistance the lead should always be disconnected from the distributor. Since the distributor terminals and the connected circuit have much lower insulation resistance than the condenser, failure to disconnect the condenser lead will give a reading much too low.

## IGNITION SYSTEM RESISTANCE TEST

Check for proper functioning of the resistance in the primary ignition circuit by turning on the ignition. With the engine not running, a voltmeter connected from the battery side of the coil to ground should read

approximately 5 to 5.7 volts. If the reading is a full 12 volts, the ignition points may be open; "bump" the starter a few times until the engine comes to rest with the ignition points closed and again check for a 5.5 volt reading. A reading of 12 volts or over for all engine positions would indicate that the shorting switch is making contact all the time; this condition must be corrected immediately or ignition point life will be very short.

Check for proper closing of the shorting switch and also for proper functioning of the complete starting circuit by grounding the secondary coil wire so the engine won't start. With the engine cranking, a voltmeter connected from the battery side of the coil to ground should read at least 9 volts. A reading of under 5 volts would indicate that the shorting switch is not closing; this condition would result in hard cold starting.

Briefly, the advantages of our resistance wire shorting switch system are: it sends full battery voltage to the coil for good cold weather starting, and it cuts down the voltage to the coil with the engine running for long ignition point life.

**NOTE:** Discourage any attempts to measure voltage at the coil with the engine running; because of variations in current flow at high speeds and in regulated voltage, this check would be meaningless. Voltage readings on a perfectly-functioning ignition system may go over 11 volts.

## SPARK PLUGS

Under normal operating conditions, spark plugs wear out due to the destructive action, under intense heat, of sulphur and lead compounds in the fuel and the bombardment of the electric spark on the electrodes.

It is reasonable to expect 12,000 miles of useful life from a spark plug which has been cleaned and regapped at regular intervals. However, operating conditions are an important factor and life expectancy of the spark plug will vary with the type of service in which the engine is used.

The same type of spark plug used in two different engines of the same make and model may frequently show wide variation in appearance. The cause of such differences lies in the condition of the engine, its piston rings, carburetor setting, kind of fuel used, and under what conditions the engine is operated, namely, sustained high speeds or heavy loads; or continual low speed, stop-and-go driving or light loads.

Spark Plugs are frequently blamed for faulty engine operation which they do not cause. Replacement of old spark plugs by new may temporarily improve poor engine performance because of the lessened demand new plugs make on the ignition system. This cannot permanently cure poor engine performance caused by worn rings or cylinders, weak coil, worn contact points, faulty carburetion or other engine ills.

On the following pages are pictures of some commonly encountered appearances and causes of spark plug problems.



Normal Operation



Deposit Fouling "A"



Deposit Fouling "B"



Carbon Fouling

### NORMAL OPERATION

Brown to grayish-tan deposits and slight electrode wear indicate correct spark plug heat range and mixed periods of high and low speed driving. **SPARK PLUGS HAVING THIS APPEARANCE MAY BE REINSTALLED. IF MISFIRING PERSISTS, SPARK PLUGS SHOULD BE REPLACED.**

When reinstalling spark plugs, be sure to use new gaskets on spark plugs that utilize engine seat gaskets.

### DEPOSIT FOULING—"A"

Red, brown, yellow and white colored coatings which accumulate on the insulator are by-products of combustion and come from the fuel and lubricating oil, both of which today generally contain additives. Most powdery deposits have no adverse effect on spark plug operation; however, they may cause intermittent missing under severe operating conditions, especially at high speeds and heavy load. **SPARK PLUGS HAVING THIS APPEARANCE SHOULD BE REPLACED.**

### DEPOSIT FOULING—"B"

Most powdery deposits, as shown in "A", have no adverse effect on the operation of the spark plug as long as they remain in the powdery state. However, under certain conditions of operation, these deposits melt and form a shiny yellow glaze coating on the insulator which, when hot, acts as a good electrical conductor. This allows the current to follow the deposits instead of jumping the gap, thus shorting out the spark plug.

Glazed deposits can be avoided by not applying sudden load, such as wide open throttle acceleration, after sustained periods of low speed and idle operation. **SPARK PLUGS HAVING THIS APPEARANCE SHOULD BE REPLACED.**

### CARBON FOULING

Dry, fluffy black carbon deposits may result from overrich carburetion, excessive hand choking, a faulty automatic choke, or a sticking manifold heat valve. A clogged air cleaner can restrict air flow to the carburetor causing rich mixtures. Poor ignition output (faulty breaker points, weak coil or condenser, worn ignition cables) can reduce voltage and cause misfiring. Fouled spark plugs are the result—not the cause—of this problem. **AFTER THE CAUSE HAS BEEN ELIMINATED, SPARK PLUGS HAVING THIS APPEARANCE SHOULD BE REPLACED.**

Excessive idling, slow speeds under light load also can keep spark plug temperatures so low that normal combustion deposits are not burned off. In such a case a hotter type spark plug will better resist carbon deposits.



Detonation

**DETONATION**

Overadvanced ignition timing, or the use of low octane fuel will result in detonation commonly referred to as engine knock.

This causes severe shock inside the combustion chamber resulting in damage to the adjacent parts which include spark plugs. A common result of detonation is to have the sidewire of a spark plug torn off.

**INSTALL A NEW PLUG OF THE RECOMMENDED HEAT RANGE AFTER PROBLEM HAS BEEN CORRECTED.**



Insufficient  
Installation Torque

**INSUFFICIENT INSTALLATION TORQUE**

Failure to install a spark plug with sufficient torque results in poor contact between the spark plug and the engine seat. The lack of proper heat transfer, resulting from poor seat contact, causes excessive overheating of the spark plug and, in many cases, severe damage as shown.

**A NEW SPARK PLUG OF THE RECOMMENDED HEAT RANGE SHOULD BE INSTALLED IN ACCORDANCE WITH AC INSTALLATION INSTRUCTIONS.**



Pre-ignition

**PRE-IGNITION**

Pre-ignition, causing burned or blistered insulator tip and badly eroded electrodes, indicates excessive overheating. Cooling system stoppages or sticking valves can also result in pre-ignition. Lean fuel-air mixtures are an additional cause.

**INSTALL A NEW PLUG OF THE RECOMMENDED HEAT RANGE AFTER PROBLEM HAS BEEN CORRECTED.**

Sustained high speed, heavy load service can produce high temperatures which will cause pre-ignition and, in this instance a colder spark plug should be used.



Improper Installation

**IMPROPER INSTALLATION**

Dirty threads in an engine head will result in the plug seizing before it is actually seated. This results in poor heat transfer and causes the spark plug to overheat.

To insure proper seating of a new spark plug in the head, dirty cylinder head threads should be cleaned with a greased thread chaser of the proper size.

**ELIMINATE THE CAUSE AND INSTALL A NEW PLUG OF THE RECOMMENDED HEAT RANGE.**



Oil Fouling



Heat Shock Failure

### OIL FOULING

Wet, oily deposits with a minor degree of electrode wear may be caused by oil pumping past worn rings. "Break-in" of a new or recently overhauled engine before rings are fully seated may also result in this condition. Other possibilities of introduction of oil into the combustion chamber are a porous vacuum booster pump diaphragm or excessive valve stem guide clearances.

**A HOTTER TYPE SPARK PLUG WILL REDUCE OIL DEPOSITS**, but too hot a spark plug can cause pre-ignition and, consequently, severe engine damage. An engine overhaul may be necessary in severe cases to obtain satisfactory service.

### HEAT SHOCK FAILURE

Heat shock is a common cause of broken and cracked insulator tips. Over-advanced ignition timing and low grade fuel are usually responsible for heat shock failures. Rapid increase in tip temperature under severe operating conditions causes the heat shock and fracture results.

Another common cause of chipped or broken insulator tips is carelessness in regapping by either bending the centerwire to adjust the gap, or allowing the gapping tool to exert pressure against the tip of the center electrode or insulator when bending the side electrode to adjust the gap.

**ELIMINATE THE CAUSE AND INSTALL A NEW PLUG OF THE RECOMMENDED HEAT RANGE.**

## STARTER SYSTEM

### INDEX

General Description .....	6Y-49	No Cranking Action .....	6Y-56
Theory of Operation.....	6Y-50	Cranking Speed Abnormally Low.....	6Y-56
Starter Motor .....	6Y-50	Voltage Test of Starting System and Solenoid	
Solenoid .....	6Y-52	Switch .....	6Y-56
Service Operation.....	6Y-54	Amperage Test of Solenoid Switch Windings.....	6Y-57
Lubrication.....	6Y-54	Checking Pinion Clearance .....	6Y-57
Starter Motor Replacement.....	6Y-54	Bench Test of Starting Motor.....	6Y-58
Diagnosis .....	6Y-56	Diagnosis Chart.....	6Y-59

## GENERAL DESCRIPTION

The function of the starting system, composed of the starting motor, solenoid and battery, is to crank the engine. The battery supplies the electrical energy, the solenoid completes the circuit to the starting motor, and the motor then does the actual work of cranking the engine.

The starting motor (fig. 1s) consists primarily of the drive mechanism, frame, armature, brushes, and field windings. The starting motor is a pad mounted 12-volt extruded frame type, having four pole shoes and four fields, connected with the armature. The aluminum drive end housing is extended to enclose the entire shift lever

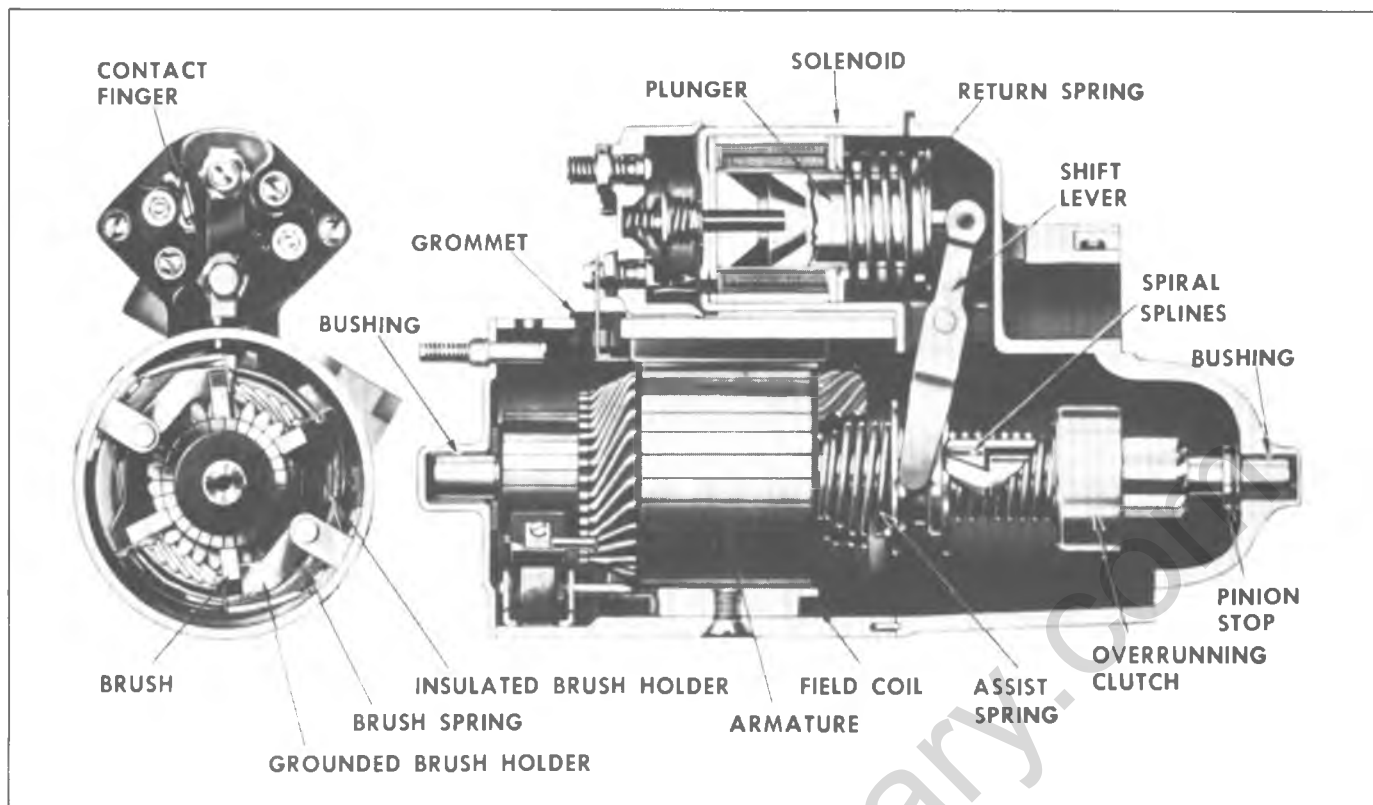

Fig. 1s—Starting Motor Cross Section (Typical)

and plunger mechanism, protecting them from dirt, splash, and icing. The drive end frame also includes a grease reservoir to provide improved lubrication of the

drive end bearing. The flange mounted solenoid switch operates the overrunning clutch drive by means of a linkage to the shaft lever.

## THEORY OF OPERATION

The starting system is made up of the cranking motor with its drive mechanism, the starter motor solenoid and the Energizer, (often referred to as the Battery). These units are connected together and work as a team to crank the engine. The simplified diagram (Fig. 2s) shows the electrical components in a typical starting system. Although modern day applications use more circuitry and controls than shown in Figure 1s, the function of the components is always the same--to convert electrical energy from the Energizer into mechanical energy at the starter motor to crank the engine.

### STARTER MOTOR

To understand the operating principles of a starter motor, think of a straight wire conductor located in the magnetic field of a horseshoe-shaped magnet. Current is flowing through the wire as shown in Figure 3s. There will be two separate magnetic fields--the one produced by the horseshoe magnet and the one produced by the current flow through the conductor.

Since magnetic lines always leave a North pole and enter a South pole, the direction of the magnetic lines between

the two poles of the horseshoe magnet will be upward as shown. The current-carrying conductor will produce a magnet field shown as circles around the wire. The net result is more magnetic lines on the left hand side of the wire than on the right (Fig. 4s).

With a strong field on one side of the conductor and a weak field on the other side, the conductor will move from the strong to the weak field, or from left to right. This magnetic force makes the cranking motor operate.

A basic motor is shown in Figure 5s. A loop of wire is placed between two iron pole pieces and is connected to two separate commutator bars. Riding on the commutator bars are two brushes, which are connected to the battery and to the windings located over the pole pieces.

Current flow can be traced from the battery through the pole piece windings, to a brush and commutator bar, through the loop of wire to the other commutator bar and brush, and then back to the battery. The magnetic fields create a turning or rotational effect in the same clockwise direction as shown in Figure 6s.

The basic motor we have used in our illustrations has no

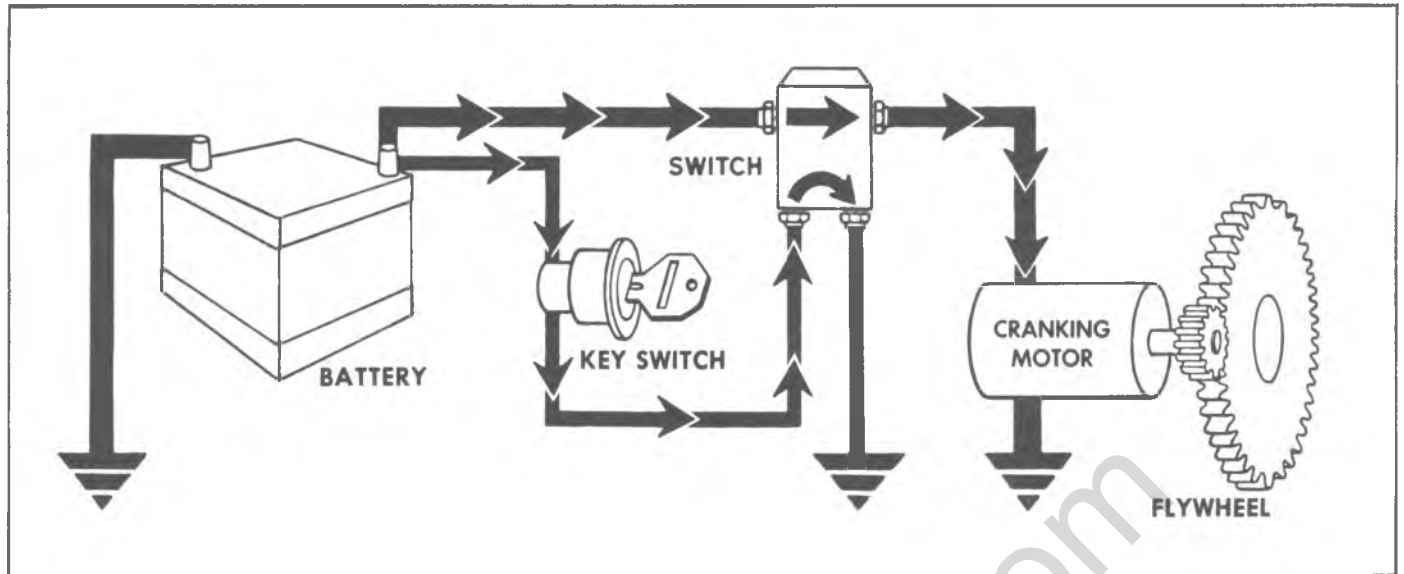

Fig. 2s—Typical Cranking System

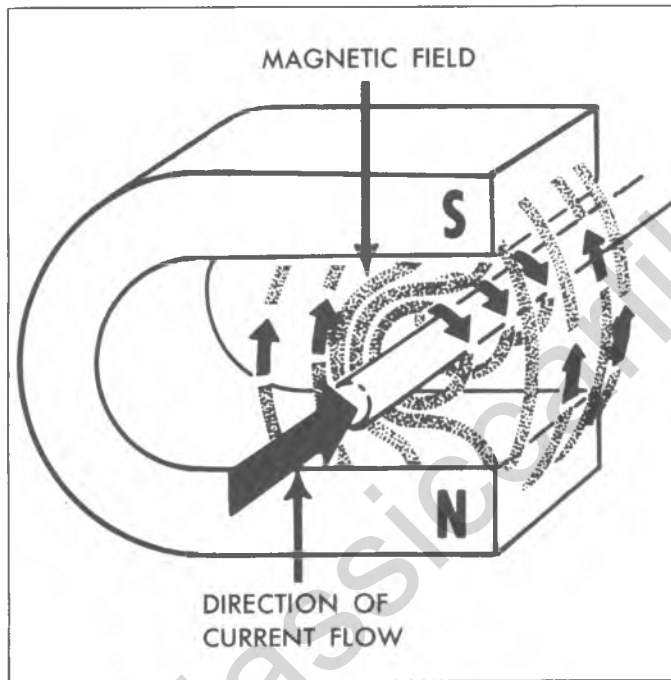

Fig. 3s—Magnetic Field of a Horseshoe Magnet

practical value. It would produce very little torque to crank an engine. It has served, however, to show the fundamental principles that operate a starter motor.

In the simplest terms, the armature is rotated by a concentration of magnetic lines on one side of the armature conductor and a lack of magnetic lines on the other side of the conductor.

### Construction

A cross-sectional view of a typical passenger car starter motor with a solenoid is shown in figure 1s.

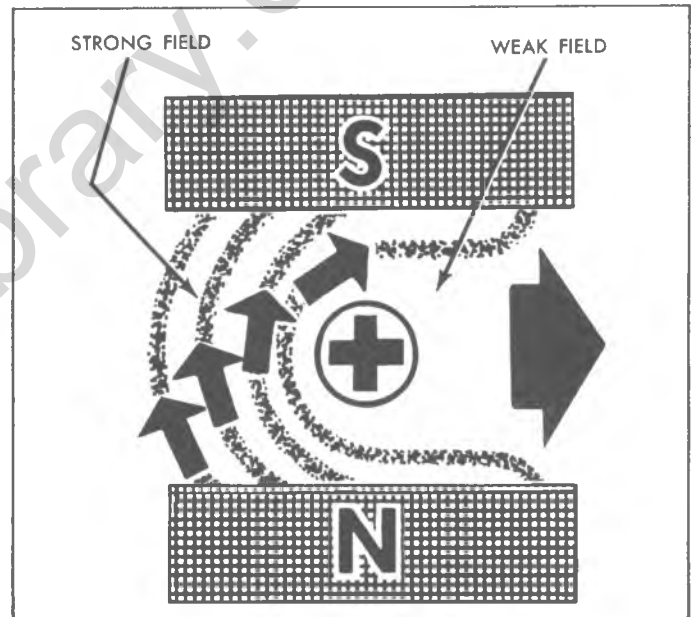

Fig. 4s—Magnetic Force

The starting motor assembly is made up of field coils placed over pole pieces which are attached to the inside of a heavy iron frame, an armature, an overrunning clutch-type drive mechanism, and a solenoid.

The iron frame and pole shoes not only provide a place for the field coils, but also provide a path for the magnetic lines produced by the field coil windings.

### Armature

The armature assembly (Fig. 7s), consists of a stack of iron laminations placed over a steel shaft, a commutator assembly and the armature winding. The windings are heavy copper ribbon that are assembled into slots in the

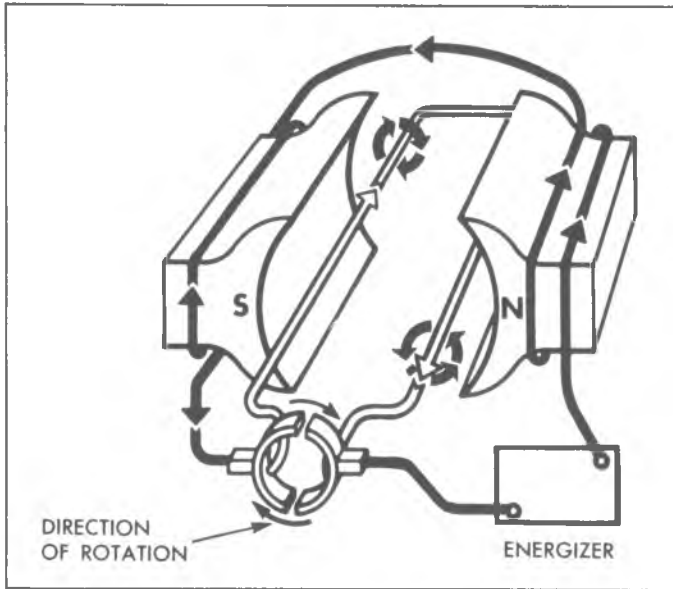

Fig. 5s—Basic Motor

iron laminations. The winding ends are soldered or welded to the commutator bars which are electrically insulated from each other and from the iron shaft.

The armature is supported by bushings in the end frames. Brushes are supported on the field frame and ride on the commutator bars.

**Drive Mechanism**

The vehicle starting motor drive mechanism (Fig. 8s) is a roll-type overrunning clutch that is assembled onto the armature shaft. Through this drive component power is transmitted from the armature to the engine during the starting cycle.

The overrunning clutch drive contains a pinion which is made to move along the shaft by means of a shift lever to engage the engine ring gear for cranking. A gear reduction is provided between the pinion and ring gear to meet the cranking requirements of the engine. With this gear reduction, the motor operates to crank the engine at speeds required for starting.

The overrunning clutch drive has a shell and sleeve

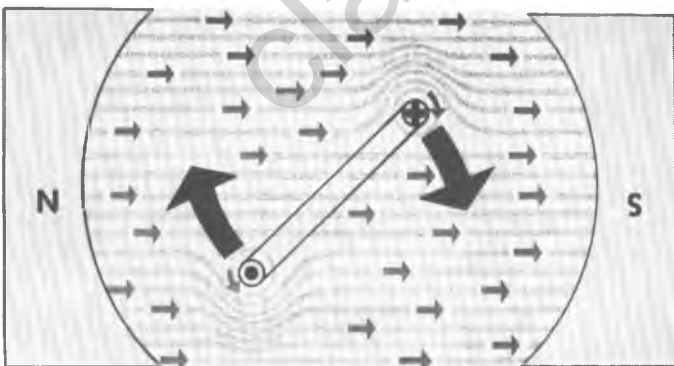

Fig. 6s—Magnetic Field Rotational Effect

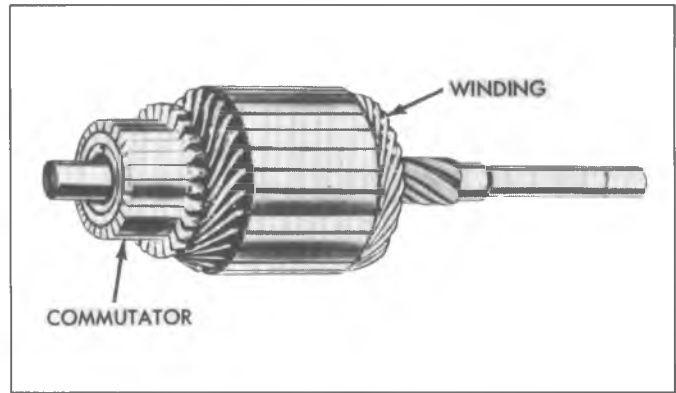

Fig. 7s—Armature Assembly

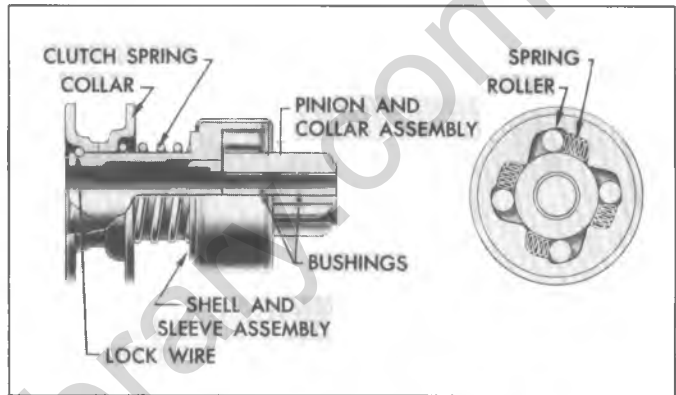

Fig. 8s—Overrunning Clutch Assembly

assembly which is splined internally to match the spiral splines on the armature shaft. The pinion is located inside the shell along with spring-loaded rollers that are wedged against the pinion and a taper inside the shell. The springs may be either a helical or accordion type. Four rolls are used. A collar and spring, located over the sleeve, are the other major clutch components.

When the shift lever is operated by the solenoid, it moves the collar endwise along the shaft. The spring pushes the pinion into mesh with the ring gear. If a tooth abutment occurs, the spring compresses until the switch is closed, at which time the armature rotates and the tooth abutment is cleared. The compressed spring then pushes the pinion into mesh and cranking begins.

Torque is transmitted from the shell to the pinion by the rolls which are wedged tightly between the pinion and taper cut into the shell.

When the engine starts, the ring gear drives the pinion faster than the armature and the rolls move away from the taper, allowing the pinion to overrun the shell. The start switch should be opened immediately when the engine starts to avoid prolonged overrun. When the shift lever is moved back by the return spring, the pinion moves out of mesh and the cranking cycle is completed.

**SOLENOID**

A sectional view of a typical solenoid is shown in Figure



9s. It performs two functions in the starting system. First, it is used to provide a circuit of short length and low resistance between the battery and motor. Since the motor may draw several hundred amperes during operation, heavy cables of short length are needed to reduce the voltage drop in the circuit.

If a solenoid switch were not used and the high motor currents were carried directly through the start switch, cables of excessive size would be required to limit the voltage drop to an acceptable value.

Since the start switch is usually some distance from the battery and solenoid switch, the long leads connected to the switch can be of reasonable size since they conduct only the small current drawn by the solenoid switch winding (Fig. 10s).

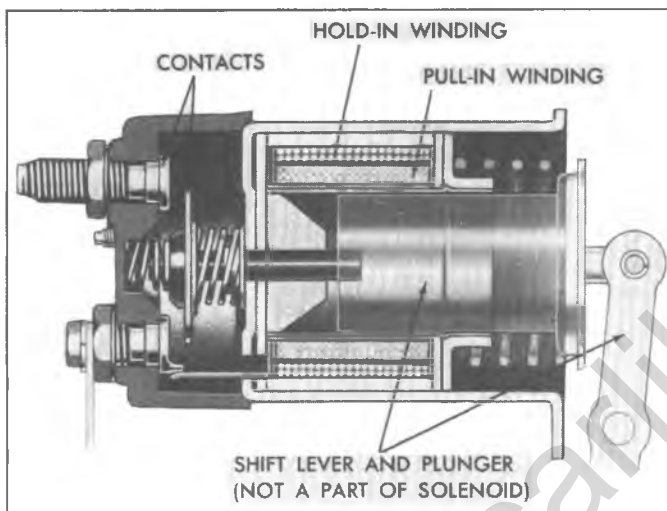

Fig. 9s—Solenoid Cross Section

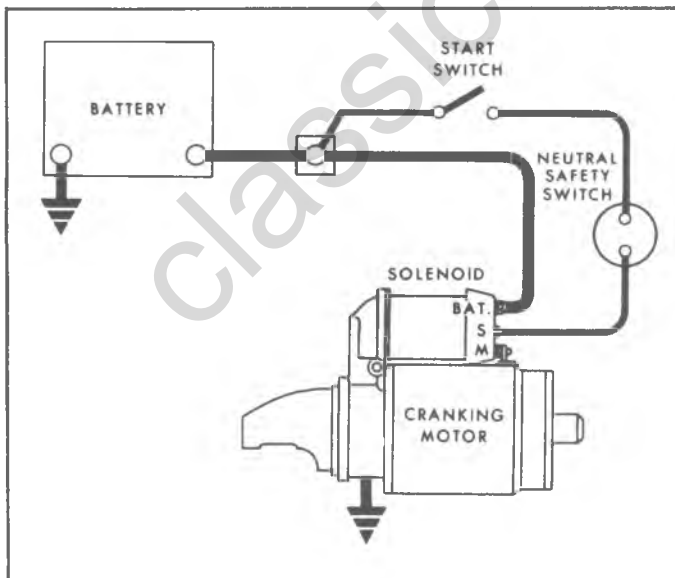

Fig. 10s—Start Switch Circuit (Typical)

Second, when the start switch is closed, the solenoid moves the pinion into mesh, and the cranking cycle begins. When the start switch is opened, the cranking cycle ends. The neutral safety switch in this type of circuit is closed only when the transmission shift lever is in the proper position, thereby preventing cranking of the engine with the transmission in gear.

The solenoid switch consists basically of two windings mounted around a hollow cylinder containing a moveable core or plunger (Fig. 9s). A shift lever is connected to the plunger. When the push rod and contact disc is pushed into firm contact with the battery and motor terminals of the solenoid, with the motor windings connected directly to the battery, cranking takes place.

The two windings in the solenoid are called the hold-in winding and the pull-in winding (Fig. 11s).

The hold-in winding contains many turns of fine wire and the pull-in winding the same number of turns of larger wire. When the start switch is closed, current flows from the battery to the solenoid (S) terminals, through the hold-in winding to ground, and then back to the battery. Current also flows through the solenoid (M) terminal and then through the motor windings to the ground.

The magnetism created by each winding adds together to form a strong magnetic field that attracts the plunger into the core. Plunger movement shifts the pinion into mesh with the ring gear and also moves the contact disc to close the circuit between the solenoid battery (B) and Motor (M) terminals. With the motor windings connected directly to the battery through the contact disc, cranking takes place.

The pull-in winding operates to assist the hold-in winding in pulling the plunger into the core. Once the

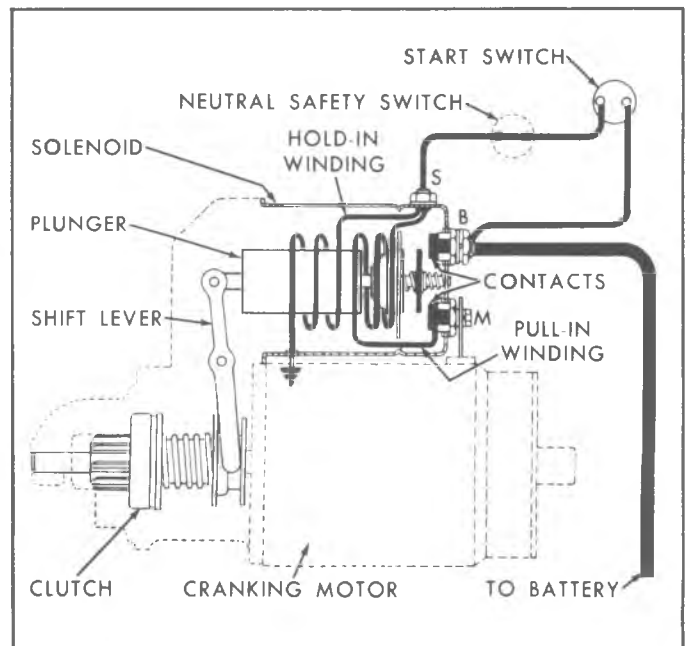

Fig. 11s—Solenoid Windings

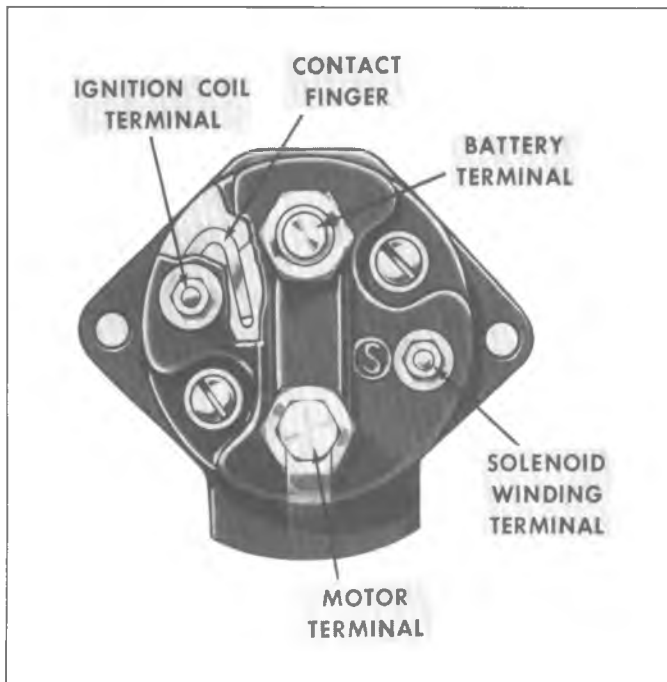

Fig. 12s—Solenoid Contact Finger

plunger movement has been completed, much less magnetism is needed to hold the plunger in the cranking position. With the contact disc contacting the battery and motor terminals of the solenoid, the pull-in winding is shorted and no current flows through it. This design feature reduces current draw on the battery and also reduces the amount of heat created in the solenoid.

When the start switch is opened, current flows for a very brief instant through the contact disc to the solenoid motor (M) terminal, through the pull-in winding in a reverse direction to the solenoid (S) terminal and then through the hold-in winding in a normal direction back to the battery. The magnetisms created by each winding oppose and cancel out each other and the return spring moves the entire shifting mechanism to the at-rest position, to complete the cranking cycle.

On most vehicle starting motors, a contact finger (Fig. 12s) touches the contact disc when the solenoid is in the cranking mode of operation. The contact finger is connected to the ignition coil terminal or (R) terminal on the solenoid, which in turn is connected directly to the ignition coil. This feature by-passes the ignition resistor and provides more available ignition voltage during cranking.

## SERVICE OPERATIONS

### STARTER MOTOR

#### Lubrication

No periodic lubrication of the starting motor or solenoid is required. Since the starting motor and brushes cannot be inspected without disassembling the unit, no service is required on these units between overhaul periods.

#### Starting Motor Replacement (Fig. 13s)

The following procedure is a general guide for all vehicles and will vary slightly depending on series and model.

1. Disconnect battery ground cable at battery.
2. Raise vehicle to a good working height.
3. Disconnect all wires at solenoid terminals.

**NOTE:** Reinstall the nuts as each wire is disconnected as thread size is different but may be mixed and stripped.

4. Loosen starter front bracket (nut on V-8 and bolt on L-6) then remove two mount bolts.

**NOTE:** On V-8 Engines incorporating solenoid heat shield, remove front bracket upper bolt and detach bracket from starter motor.

5. Remove the front bracket bolt or nut and rotate bracket clear of work area then lower starter from vehicle by lowering front end first -- (hold starter against bell housing and sort of roll end-over-end).
6. Reverse the removal procedure to install. Torque the mount bolts to 25-35 ft. lbs. first, then torque brace bolt.
7. Check operation of starter on vehicle.

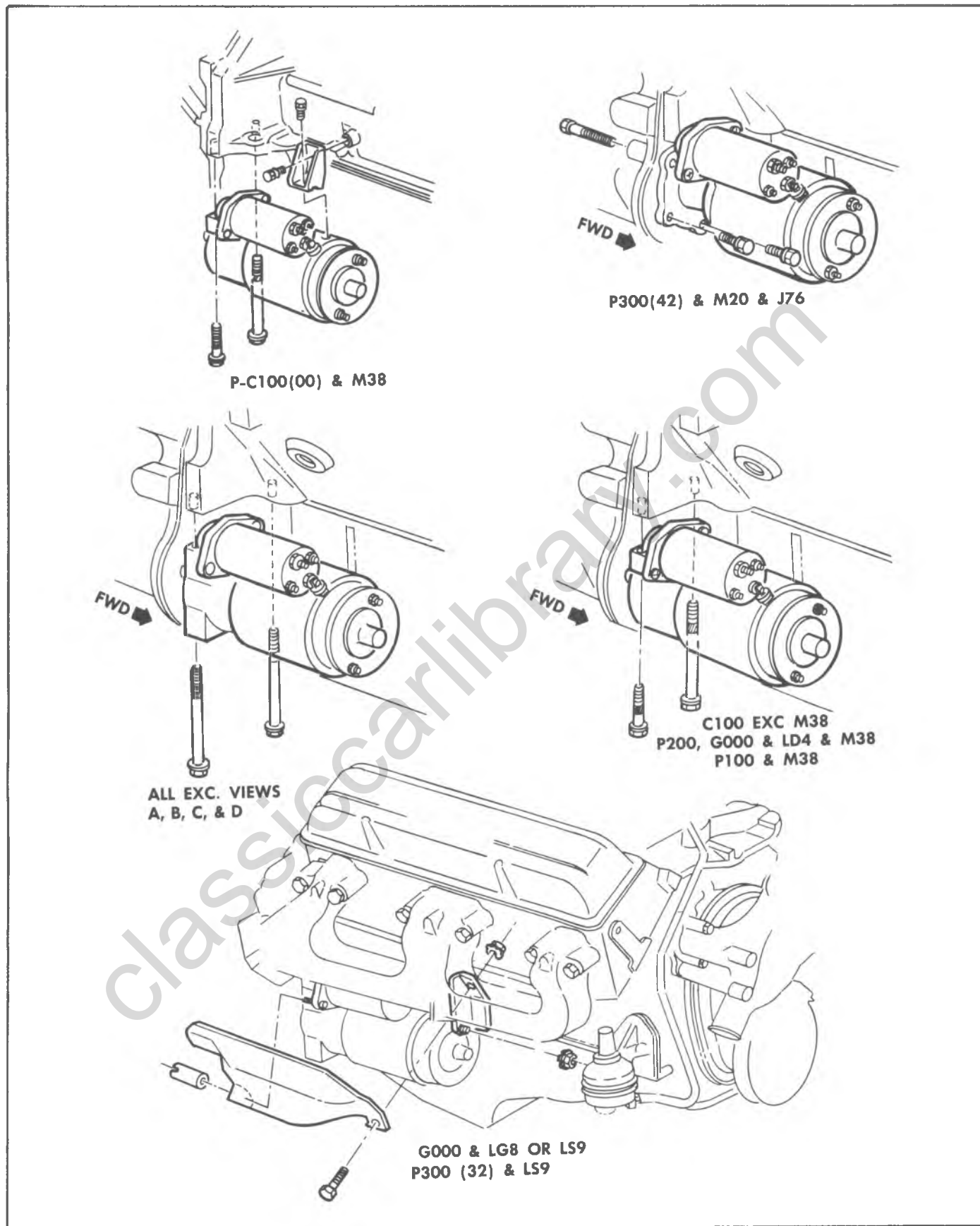

Fig. 13s—Starter Mounting Installation

## DIAGNOSIS

### NO CRANKING ACTION

1. Make sure that control lever is neutral (N) or park (P) position or that clutch pedal is depressed on manual transmission.
2. Make quick check of battery and cables. If battery is low, the solenoid usually will produce a clattering noise, because a nearly discharged battery will not sustain the voltage required to hold solenoid plunger in after solenoid switch as been closed.
3. If starter motor spins and drive pinion engages ring gear but does not drive it, overrunning clutch is slipping. Remove motor to replace drive assembly.
4. If starter motor does not operate, note whether solenoid plunger is pulled into solenoid when solenoid circuit is closed. Ordinarily the plunger makes a loud click when it is pulled in. If plunger is pulled in, solenoid circuit is okay and trouble is in solenoid switch, cranking motor, or cranking motor circuit. The starter motor must be removed for repairs to switch or motor.
5. If plunger does not pull into solenoid when ignition switch is turned to "START", the solenoid circuit is open, or solenoid is at fault.
6. To find reason why plunger does not pull into solenoid, connect jumper between solenoid battery terminal and terminal on solenoid switch to which purple wire is connected. If cranking motor operates, solenoid is okay; trouble is in ignition switch, neutral start switch, or in wires and connections between these units.
7. If starter motor still does not operate, remove motor for inspection and test of solenoid switch.

### CRANKING SPEED ABNORMALLY LOW

Abnormally low cranking speed may be caused by low battery or defective cables, defective solenoid switch, defective cranking motor, or an internal condition of engine.

1. Make quick check of battery. If low battery is indicated, test battery. If defective cables are indicated, test cables.

**NOTE:** Check generator belt tension for cause of low battery.

2. If battery and cables are okay, test cranking motor and solenoid switch.
3. If starter motor and solenoid switch test okay, the trouble is due to an internal condition of engine. This may be due to use of engine oil which is too heavy for prevailing temperatures.

### VOLTAGE TEST OF STARTING SYSTEM AND SOLENOID SWITCH

The voltage across the starter motor and switch while cranking the engine gives a good indication of any excessive resistance.

**NOTE:** Engine must be at normal operating temperature when test is made.

1. Inspect battery and cables to make certain that battery has ample capacity for cranking and ignition.
2. Connect jumper wire to distributor terminal of coil and to ground on engine, so that engine can be cranked without firing.
3. Connect voltmeter positive lead to the motor terminal on solenoid switch; connect voltmeter negative lead to ground (Fig.14s).
4. Turn ignition switch on, crank engine and take voltmeter reading as quickly as possible. If cranking motor turns engine at normal cranking speed with voltmeter reading 9 or more volts, the motor and switch are satisfactory. If cranking speed is below normal and voltmeter reading is 9 volts or greater, the cranking motor is defective.

**CAUTION:** Do not operate starter motor more than 30 seconds at a time without pausing to allow motor to cool for at least two minutes; otherwise, overheating and damage to motor may result.

5. If starter motor turns engine at low rate of speed with voltmeter reading less than 9 volts, test solenoid switch contacts as follows:
6. With voltmeter switch turned to any scale above 12 volts, connect voltmeter negative lead to the motor

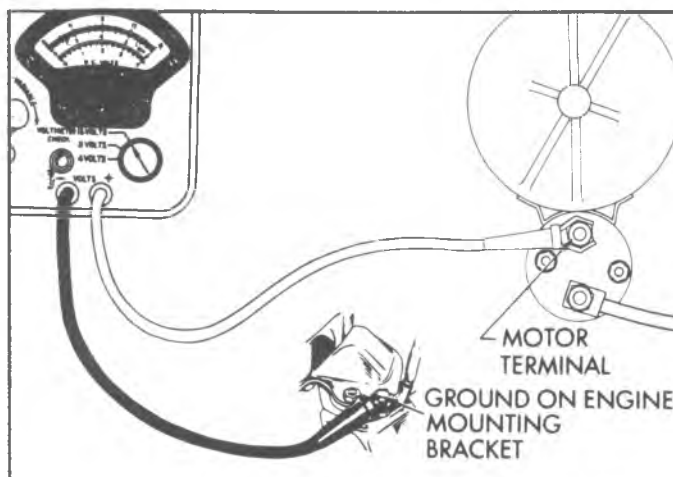

Fig. 14s—Cranking Voltage Test Connections

terminal of solenoid switch, and connect positive lead to battery terminal of switch (Fig. 15s).

- Turn ignition switch on and crank engine. Immediately turn voltmeter switch to low scale and take reading as quickly as possible, then turn switch back to higher scale and stop engine.

The voltmeter will read not more than 2/10 volt if switch contacts are satisfactory. If voltmeter reads more than 2/10 volt, switch should be repaired or replaced.

### AMPERAGE TEST OF SOLENOID SWITCH WINDINGS

- Current draw of both windings in parallel.
- Current draw of hold-in winding alone.
  - Remove screw from solenoid motor terminal and bend field leads slightly until clear of terminal. Then ground solenoid motor terminal with a heavy jumper wire (Fig. 16s).
  - Connect a 12-volt battery, a variable resistance, and an ammeter of 100 amperes capacity in series with solenoid "S" terminal. Connect a heavy jumper wire from solenoid base to ground post of battery.

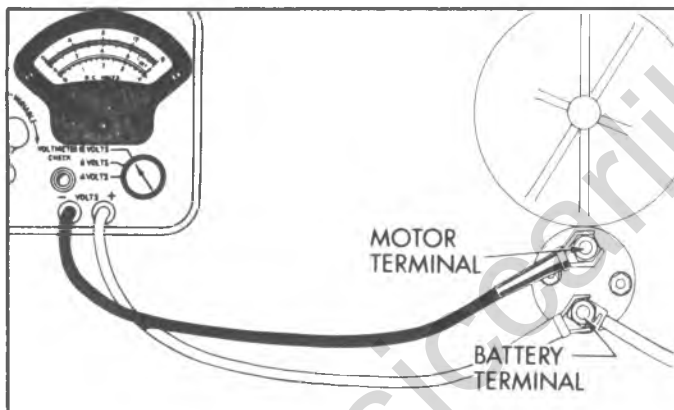

Fig. 15s—Solenoid Switch Contact Test Connections

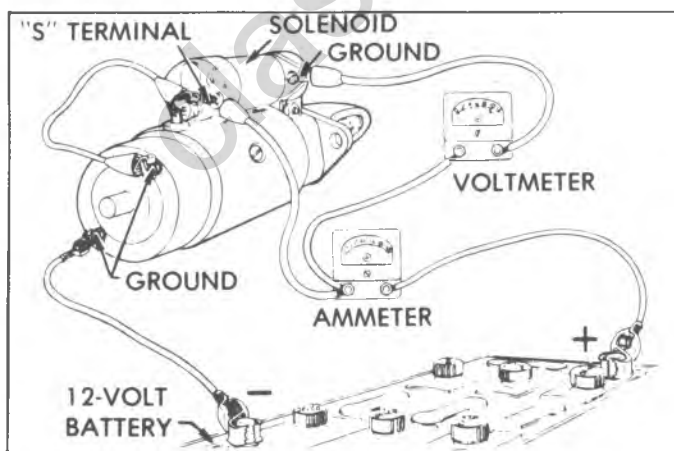

Fig. 16s—Amperage Test of Solenoid

- Connect a voltmeter between base of solenoid and small solenoid "S" terminal.
- Slowly adjust resistance until voltmeter reads 10 volts and note ammeter reading. This shows current draw of both windings in parallel. Refer to Delco-Remy bulletin for specifications on the starter being tested.
- Remove jumper wire from solenoid motor terminal and re-adjust resistance until voltmeter reads 10 volts, then note ammeter reading. This shows current draw of hold-in winding alone. Refer to Delco-Remy bulletin for specifications.
- If solenoid windings do not test within specifications given, solenoid switch assembly should be replaced.

### CHECKING PINION CLEARANCE

Whenever the starter motor is disassembled and reassembled, the pinion clearance should be checked. This is to make sure that proper clearance exists between the pinion and pinion stop retainer when pinion is in cranking position. Lack of clearance would prevent solenoid starter switch from closing properly; too much clearance would cause improper pinion engagement in ring gear.

- Connect a source of approximately 6 volts (3 battery cells or a 6 volt battery) between the solenoid "S" terminal and ground.

**CAUTION:** Do not use more than 6 volts or the motor will operate. As a further precaution to prevent motoring, connect a heavy jumper wire from the solenoid motor terminal to ground.

- After energizing the solenoid, push the pinion away from the stop retainer as far as possible and use

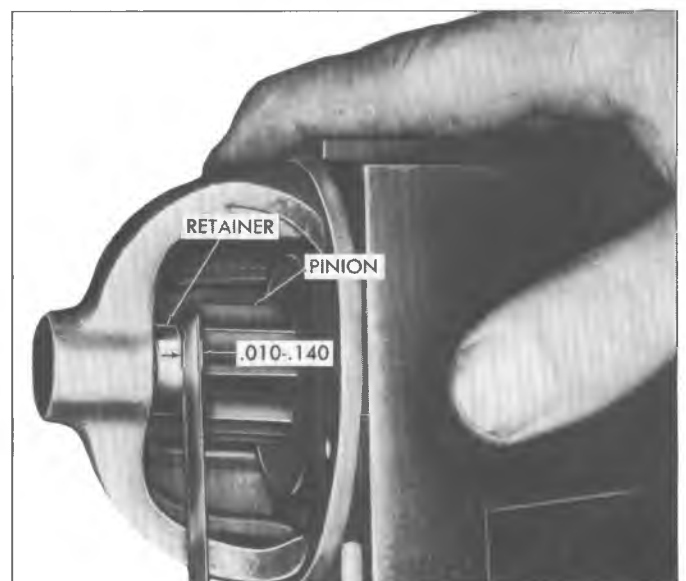

Fig. 17s—Checking Pinion Clearance

feeler gauge to check clearance between pinion and retainer (Fig. 17s).

3. If clearance is not between .010" and .140" it indicates excessive wear of solenoid linkage, shift lever mechanism, or improper assembly of these parts.

NOTE: Pinion clearance cannot be adjusted. If clearance is not correct, motor must be disassembled and checked for the above mentioned defects. Any defective parts must be replaced.

### BENCH TEST OF STARTING MOTOR

To obtain full performance data on a cranking motor, or to determine the cause of abnormal operation, the motor should be removed from the engine and be submitted to a no-load test with equipment designed for such tests. A high current carrying variable resistance should be connected into the circuit so that the specified voltage at the starter motor may be obtained, since a small variation in the voltage will produce a marked difference in the current draw.

- (a) No-Load Test. Connect the starter motor in series with a 12 volt-battery and an ammeter capable of indicating several hundred amperes. If an RPM indicator is available, set it up to read armature RPM. Check current draw and armature RPM at the specified voltage.

1. Low no-load speed and high current draw may result from:
  - (a) Tight, dirty, or worn bearings, bent armature shaft or loose field pole screws which would allow the armature to drag.
  - (b) Shorted armature. Check armature further on growler.
  - (c) A grounded armature or field.

Check for grounds by raising the grounded brushes and insulating them from the commutator. If the starter

motor has shunt field coils which are grounded to the field frame, disconnect these fields from ground. Then check with a test lamp between the insulated terminal and the frame. If lamp lights, raise other brushes from commutator and check fields separately to determine whether it is the fields or armature that is grounded:

2. Failure to operate with high current draw may result from:
  - (a) A direct ground in the terminal or fields.
  - (b) Frozen shaft bearings which prevent the armature from turning.
3. Failure to operate with no current draw may result from:
  - (a) Open field circuit. Inspect internal connections and trace circuits with test lamp.
  - (b) Open armature coils. Inspect the commutator for badly burned bars.
  - (c) Broken or weakened brush springs, worn brushes, high mica on the commutator, or other causes which would prevent good contact between the brushes and commutator. Any of these conditions will cause burned commutator bars.
4. Low no-load speed with low current draw indicates:
  - (a) An open field winding. Raise and insulate ungrounded brushes from commutator and check fields with test lamp.
  - (b) High internal resistance due to poor connections, defective leads, dirty commutator and causes listed under item 3 (c).
5. High no-load speed with high current draw indicates shorted fields. There is no easy way to detect shorted fields, since the field resistance is already low. If shorted fields are suspected, replace the fields and check for improvement in performance.

## DIAGNOSIS CHART

## NOTHING HAPPENS WHEN START ATTEMPT IS MADE

PROBABLE CAUSE	REMEDY
1. Undercharged or defective energizer.	Check condition of energizer and recharge or replace as required.
2. Loose energizer cables.	Clean and tighten cable connections.
3. Burned fusible link in starting circuit.	Check for burned fusible link. Correct wiring problem.
4. Incorrectly positioned or defective neutral start switch.	Check neutral start switch adjustment. If O.K., replace switch.
5. Loose or defective wiring between neutral start switch and ignition switch.	Check for loose connections and opens between energizer, horn relay, ignition switch, and solenoid "S" terminal. Check energizer ground cable. Replace or repair defective item.
6. Defective starter motor.	Repair or replace starter motor.
7. Defective starter interlock system.	Refer to Section 12, for Diagnosis and Service Procedures.

## SOLENOID SWITCH CLICKS BUT STARTER DOES NOT CRANK

PROBABLE CAUSE	REMEDY
1. Undercharged or defective energizer.	Test energizer. Recharge or replace energizer.
2. Loose energizer cables.	Check and tighten energizer connections.
3. Loose or defective wiring at starter.	Tighten connections or repair wiring as required.
4. Defective solenoid.	Replace solenoid.
5. "Hot stall" condition.	Check engine cooling system.
6. Excessive engine rotational torque caused by mechanical problem within engine.	Check engine torque for excessive friction.
7. Defective starter motor.	Repair or replace starter motor.

## SOLENOID SWITCH PUMPS IN AND OUT

PROBABLE CAUSE	REMEDY
1. Undercharged or defective energizer.	Test energizer. Recharge or replace energizer.
2. Loose connections or opens between energizer, horn relay, ignition switch, neutral start switch, and solenoid "S" terminal, plus energizer ground cable.	Replace or repair wiring or switches.
3. Defective solenoid	Replace solenoid.

## STARTER KEEPS RUNNING AFTER IGNITION SWITCH IS RELEASED - FROM "START" TO "RUN" POSITION

PROBABLE CAUSE	REMEDY
1. Defective ignition switch.	Replace ignition switch.
2. Defective solenoid	Replace solenoid.

## STARTER SPINS AND/OR MAKES LOUD GRINDING NOISE BUT DOES NOT TURN ENGINE

PROBABLE CAUSE	REMEDY
1. Defective starter motor.	Repair or replace starter motor.
2. Defective Ring Gear	Replace Ring Gear

## SLOW CRANKING

PROBABLE CAUSE	REMEDY
1. Vehicle is overheating.	Check engine cooling system and repair as required.
2. Undercharged or defective energizer.	Recharge or replace energizer.
3. Loose or defective wiring between energizer and engine block.	Repair or replace wiring.
4. Loose or defective wiring between energizer and solenoid "Bat." terminal.	Repair or replace wiring.
5. Defective starter motor.	Repair or replace starter.

STARTER ENGAGES ("CLUNKS")  
BUT ENGINE DOES NOT CRANK

PROBABLE CAUSE	REMEDY
1. Open circuit in solenoid armature or field coils.	Repair or replace solenoid or starter motor.
2. Short or ground in field coil or armature.	Repair or replace starter motor.

## Special Tools

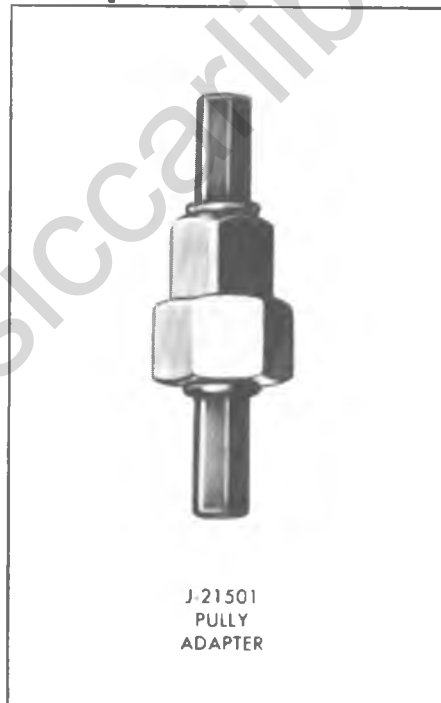

Fig. 18s—Special Tools



## SECTION 7M

## CLUTCHES &amp; MANUAL TRANSMISSIONS

## CONTENTS OF THIS SECTION

Clutch Controls.....	7M-1	Manual Transmissions .....	7M-17
Clutches.....	7M-9	Special Tools .....	7M-46

## CLUTCH CONTROLS

## INDEX

General Description .....	7M-1	Clutch Free Pedal Travel Adjustment.....	7M-5
Maintenance and Adjustments .....	7M-5	Insufficient Clutch Release.....	7M-5
Clutch Linkage Inspection .....	7M-5	Clutch Pedal Arm Assembly Replacement .....	7M-6
		Clutch Cross Shaft Replacement .....	7M-7

## GENERAL DESCRIPTION

The clutch operating controls for C-K trucks (fig. 1a) are a mechanical type consisting of a pendant type pedal, return spring, pedal push rod, cross-shaft, fork push rod, clutch fork and throwout bearing. The pedal push rod is routed vertically, inside the cab, from the pedal lever down through two boots on the toe pan, to the cross-shaft lever. When the clutch pedal is depressed, the pedal push rod moves rotating the cross-shaft, pushing the fork push rod rearward, and pivoting the clutch fork to move the throwout bearing against the clutch release fingers and releasing the clutch.

The clutch operating controls for "G" and "P" models are a mechanical type similar to the C-K models. On

"G" models (fig. 1b), a pedal pull rod is routed vertically from the clutch pedal lever down through the toe panel to the cross shaft. When the pedal is depressed, the pedal pull rod moves rotating the cross shaft, pushing the clutch fork rod rearward and pivoting the clutch fork. This action moves the throwout bearing against the clutch release fingers, releasing the clutch.

"P" model controls (fig. 1c) have an upper pull rod connected from the clutch pedal shaft to a bell crank and a lower pull rod from the bell crank to the cross shaft. When the pedal is depressed, the pull rods are moved rotating the cross shaft and pushing the clutch fork rearward, thus subsequently activating the clutch release mechanism.

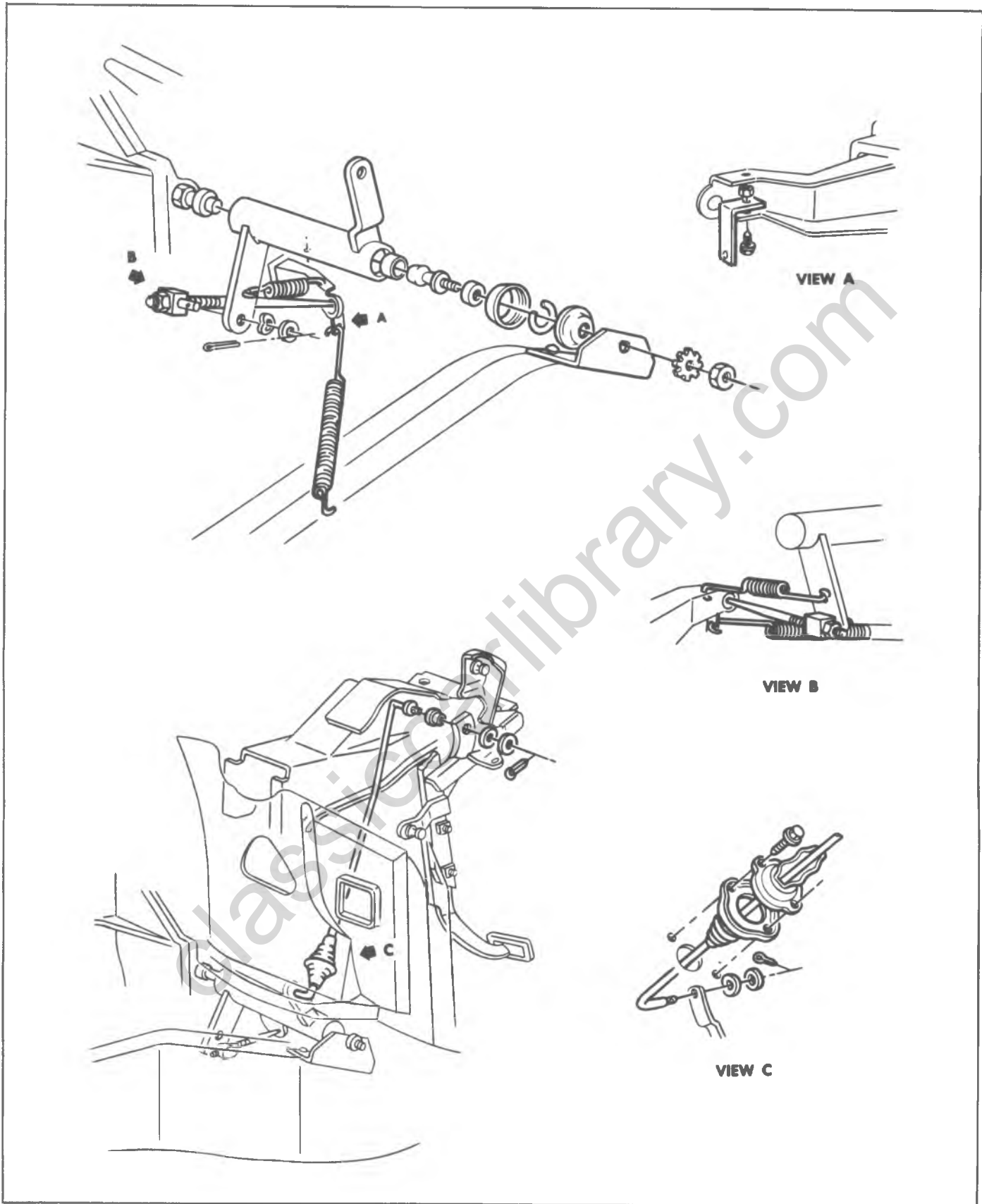

Fig. 1a—Clutch Linkage Assy. (C-K Models)

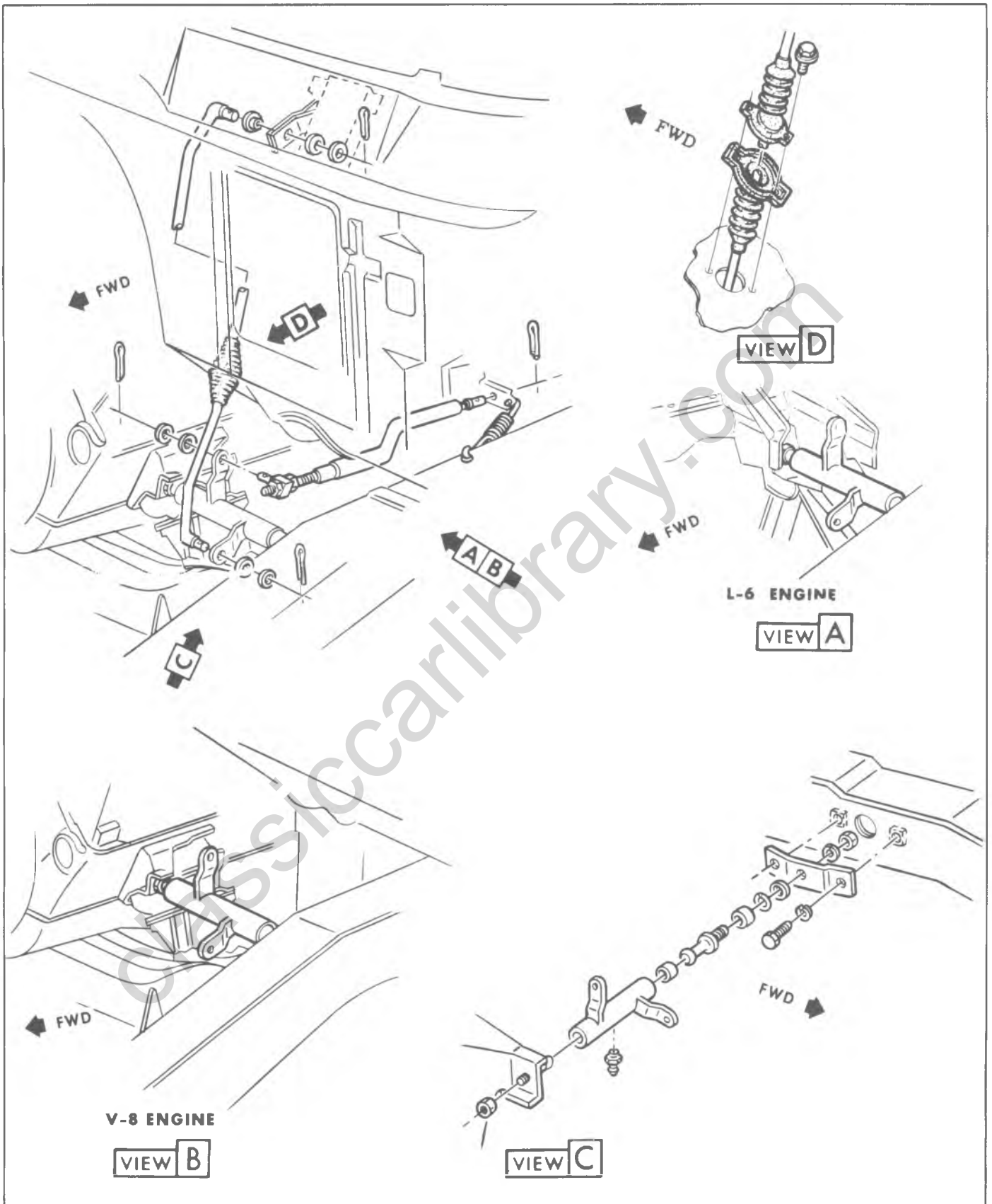

Fig. 1b—Clutch Linkage Assy. (G Models)

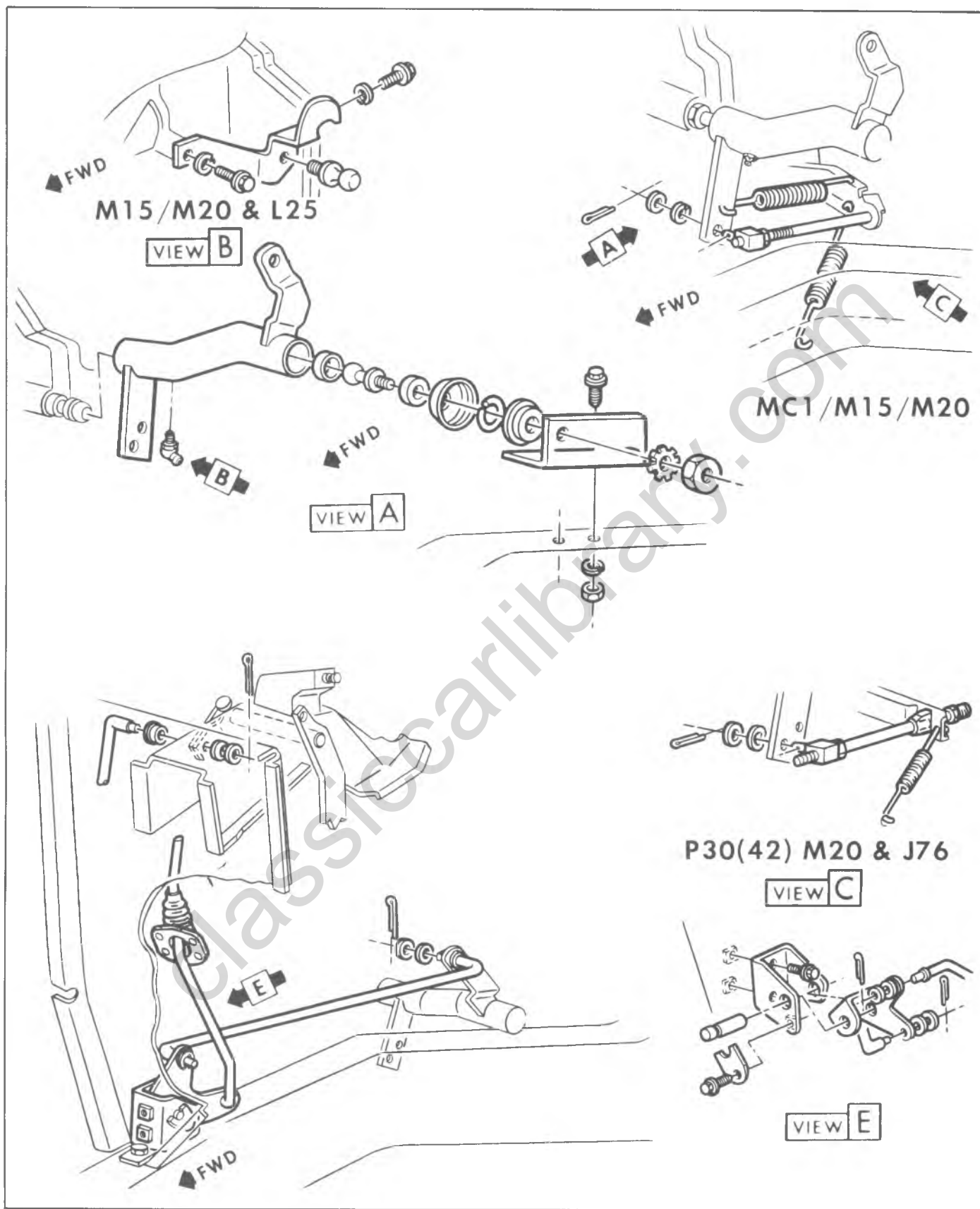

Fig. 1c—Clutch Linkage Assy. (P Models)

## MAINTENANCE AND ADJUSTMENTS

### CLUTCH LINKAGE INSPECTION

There are several things which affect good clutch operations. Therefore, it is necessary, before performing any major clutch operations, to make preliminary inspections to determine whether trouble is actually in the clutch.

Check the clutch linkage to be sure the clutch releases fully as follows:

1. With engine running, hold the clutch pedal approximately 1/2" from floor mat and move shift lever between first and reverse several times. If this can be done smoothly, the clutch is fully releasing. If shift is not smooth, clutch is not fully releasing and adjustment is necessary.
2. Check clutch pedal bushings for sticking or excessive wear.
3. Check fork for proper installation on ball stud. Lack of lubrication on fork can cause fork to be pulled off the ball.
4. Check for bent, cracked or damaged cross shaft levers or support bracket.
5. Loose or damaged engine mounts may allow the engine to shift its position causing a bind on clutch linkage at the cross shaft. Check to be sure there is some clearance between cross shaft, both mount brackets, and ball studs.
6. Check throw out bearing end clearance between spring fingers and front bearing retainer on the transmission. If no clearance exists, fork may be improperly installed on ball stud or clutch disc may be worn out.

### CLUTCH FREE PEDAL TRAVEL ADJUSTMENT

Only one adjustment is necessary to compensate for all normal clutch wear. The clutch pedal should have free travel (measured at clutch pedal pad) before the throwout bearing engages the clutch diaphragm spring or levers. Lash is required to prevent clutch slippage which would occur if the bearing was held against the fingers or to prevent the bearing from running continually. A clutch that has been slipping prior to free play adjustment may still slip right after the new adjustment due to previous heat damage.

#### C, K and P Models Except P30 W/J76

1. Disconnect return spring at clutch fork.
2. Rotate clutch lever and shaft assembly until clutch pedal is firmly against rubber bumper on brake pedal bracket.
3. Push outer end of clutch fork rearward until throwout bearing lightly contacts pressure plate fingers or levers.

4. Loosen lock nut and adjust rod length so that swivel slips freely into gauge hole. Increase pushrod length until all lash is removed from system.
5. Remove swivel from gauge hole and insert into lower hole on lever. Install two washers and cotter pin. Tighten lock nut being careful not change rod length.
6. Reinstall return spring and check pedal free travel. Pedal travel should be 1 3/8" to 1 5/8" on "C-K" models and 1 1/4" to 1 1/2" on "P" models.

#### P-30 Models W/J76 (Fig. 2)

1. Disconnect clutch fork return spring.
2. Loosen nut "G" at swivel.
3. Move the clutch fork rod against fork to eliminate all clearance between throwout bearing and clutch fingers.
4. Rotate shaft lever until clutch pedal contacts the bumper mounted on the brake pedal bracket.
5. Rotate the fork rod until a clearance of approximately 1/4" to 5/16" (.29) is obtained between the shoulder on the fork rod and the adjustment nut.
6. Tighten nut "G" against swivel and install clutch return spring.
7. Check free pedal clearance at pedal. Pedal clearance should be 1 3/8" to 1 5/8". Readjust as required.

#### G-Models (Fig. 3)

1. Disconnect clutch fork return spring at fork.
2. Loosen nut "A" and back off from swivel approximately 1/2 inch.
3. Hold clutch fork push rod against fork to move throwout bearing against clutch fingers (push rod will slide through swivel at cross-shaft).
4. Adjust nut "B" to obtain approximately 1/4" clearance between nut "B" and swivel.
5. Release push rod, connect return spring and tighten nut "A" to lock swivel against nut "B".
6. Check free pedal clearance at pedal (1 1/4" to 1 1/2" is proper clearance). Readjust if necessary.

### INSUFFICIENT CLUTCH RELEASE

Where complaints of first or reverse gear clash due to insufficient clutch release are encountered, the following may be helpful. Cut off the existing clutch pedal stop bumper to a height of 3/8". Since shortening the bumper increases the lash and not the usable stroke, the lash must be reduced to specifications in order to gain the additional stroke benefit.

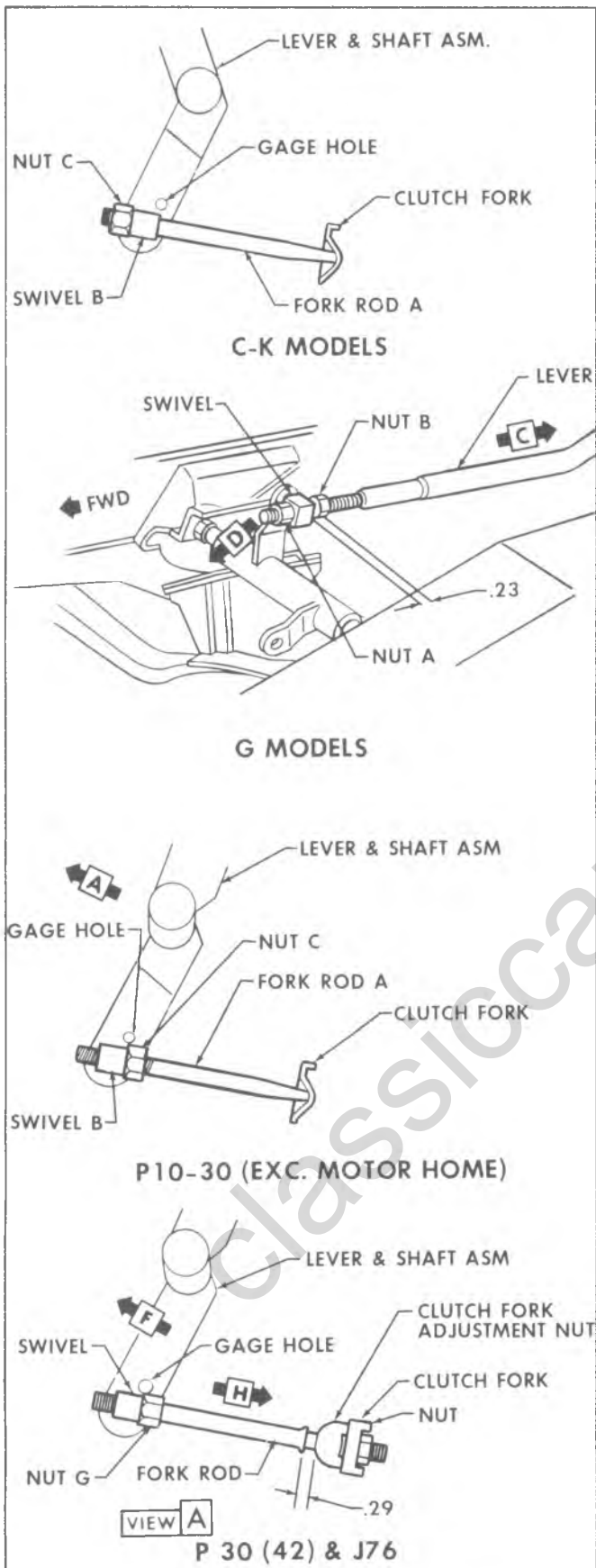

Fig. 2—Clutch Pedal Free Travel Adjustment

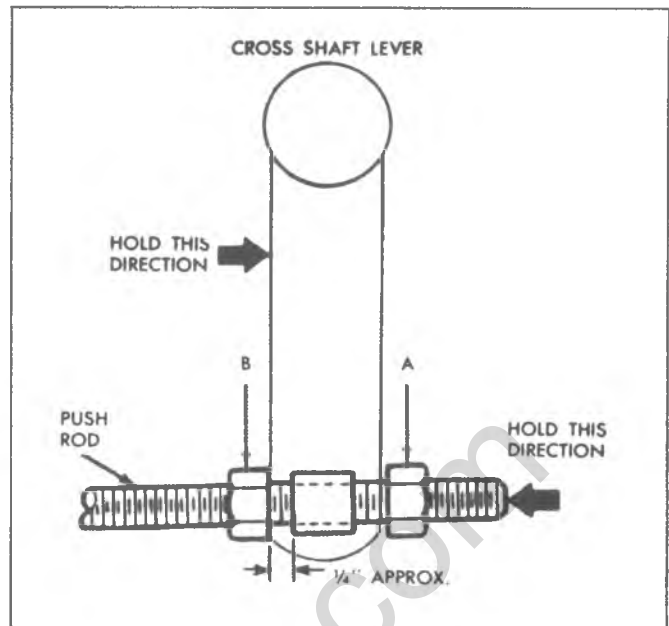

Fig. 3—Free Travel Adjustment (G Models)

### CLUTCH PEDAL ARM, PUSH ROD OR BUSHING REPLACEMENT (Fig. 4)

#### C-K Models

##### Removal

1. Disconnect battery negative ground cable at the battery terminal.
2. Disconnect clutch push rod at the cross shaft under the vehicle.
3. Remove steering column covers. Remove screws retaining push rod boots to bulkhead.
4. Remove air conditioning duct from lower left side of instrument cluster if so equipped. (Refer to Section 1A, Truck Service Manual for A/C Service Information).

**CAUTION:** Maintain pressure on lower arm. When lower attaching bolt is removed upper section will snap upward.

5. Disconnect clutch neutral start switch from pedal arm.
6. Remove bolts attaching lower section of clutch pedal arm to the upper arm.
7. Remove lower arm and push rod from vehicle.
8. Remove pedal return spring.
9. Remove pedal pivot shaft retaining nut and pivot shaft. Insert a dummy shaft or rod through the support to hold the brake pedal components in place.
10. Remove the clutch pedal assembly from the support assembly.
11. Remove pedal bushings and spacer from pedal

arm. Check pedal bumper for wear and replace as required.

#### Installation

1. Install new bushings and spacer in pedal arm. Components should be lubricated prior to assembly.
2. Position clutch pedal upper arm in support bracket and install pivot bolt through support and pedal arms.  
NOTE: Bolt must be installed in direction shown in figure 4 in order to clear return spring.
3. Install pivot bolt retaining nut and torque to specifications.
4. Install pull back spring to support and pedal arm.  
NOTE: If previously removed, connect pedal push rod to clutch pedal arm.
5. Position lower pedal arm to upper arm and install upper attaching bolt. Push down on pedal and install lower bolt. Torque to specifications.
6. Install clutch neutral start switch.
7. Install air conditioning duct.
8. Install steering column covers. Install screws retaining push rod boots to bulk head.
9. Check operation of clutch assembly and adjust clutch as required.

#### G and P Models (Fig. 4)

##### Removal

1. Apply parking brake firmly. Disconnect neutral start switch from pedal arm.
2. Remove bolt at clutch pedal push rod lever, then remove lever from pedal shaft.
3. Hold pedal pad with one hand and slide clutch pedal and shaft assembly outboard enough to clear pedal stop. Insert a dummy shaft or rod through support and brake pedal assembly to hold components in place while removing clutch pedal shaft. Allow return spring (or center spring) to pull pedal up high enough to unhook spring from pedal arm.

4. Remove pedal and shaft assembly from support bracket.

##### Inspection

1. Check clutch pedal bushings for excessive wear and replace as necessary.
2. Check clutch pedal shaft for wear and alignment. Straighten or replace as necessary.

##### Installation

NOTE: Use new shaft bushing if needed. Lubricate with Lubriplate or petrolatum.

1. Slide one pedal shaft bushing over shaft, install shaft in support enough to still clear pedal bumper stop. hook pedal return (or overcenter) spring to pedal, then rotate pedal forward of bumper stop; slide shaft into position in support and release pedal against bumper stop.
2. Install clutch pedal shaft bushing over pedal shaft end and into place in sleeve.
3. Assemble pedal push rod lever over pedal shaft and install bolts, washers, and nut.
4. Connect neutral start switch to pedal arm.
5. Adjust clutch pedal free travel as needed.

#### CLUTCH CROSS-SHAFT REPLACEMENT (Fig. 1)

##### Removal

1. Disconnect clutch fork return spring at fork.
2. Disconnect pedal push rod at cross-shaft lever and allow clutch fork push rod to hang free from lower lever.
3. On C-K models, remove ball stud retaining nut, at frame end and slide shaft toward engine. Then lift cross-shaft up to clear bracket and remove shaft from the engine ball stud. On panel G models, remove frame bracket retaining bolts, then remove shaft from engine ball stud.
4. Remove clutch fork push rod from cross-shaft lever.
5. Reverse removal procedure to install.

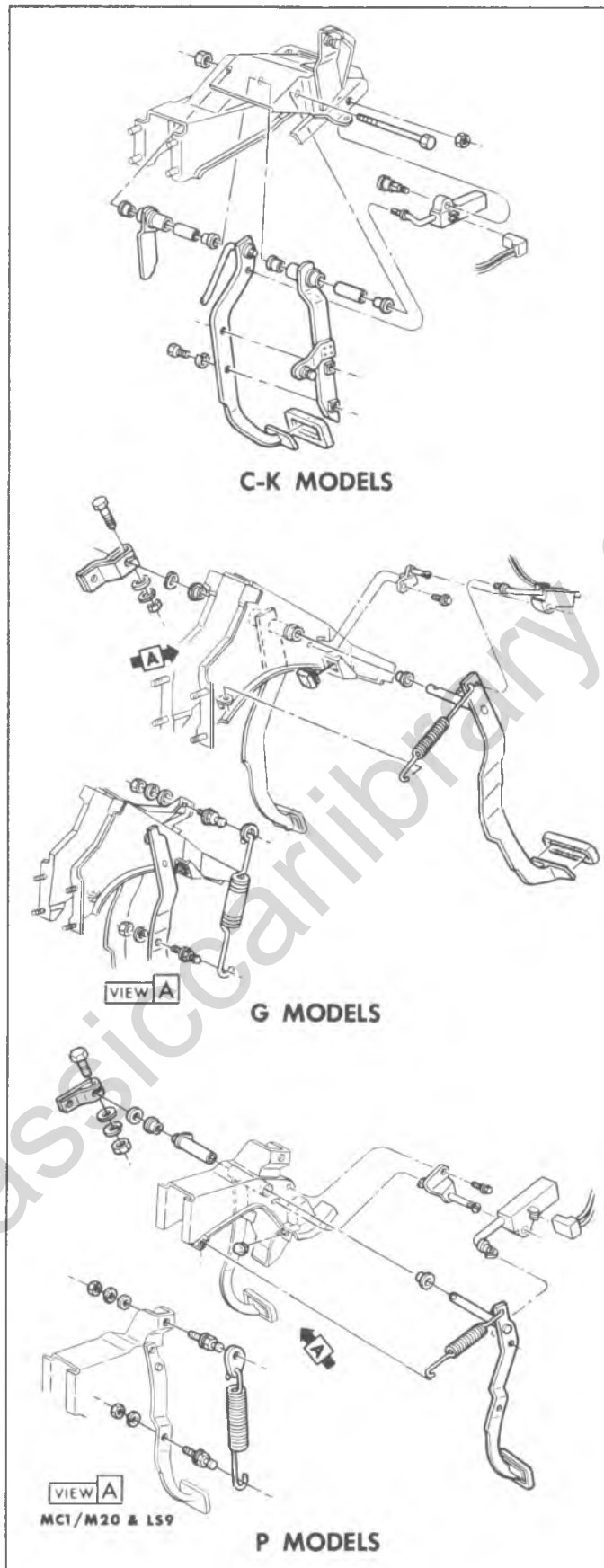

Fig. 4—Clutch Pedal Assy.



# CLUTCHES

## DIAPHRAGM SPRING CLUTCH

### INDEX

Theory of Operation.....	7M-9	Service Operations.....	7M-13
Clutch.....	7M-9	Preliminary Inspection.....	7M-13
Clutch Components.....	7M-9	Clutch Replacement.....	7M-13
Clutch Operation.....	7M-12	Diagnosis.....	7M-16

## THEORY OF OPERATION

### CLUTCH

Automotive clutches depend on friction for their operation, whether it be solid friction as in the conventional clutch, or fluid friction and inertia as utilized in the fluid coupling and torque converter. The fluid coupling serves the same purpose as the conventional clutch, but the difference in the principle of operation makes it necessary to discuss the two mechanisms separately. Conventional clutches will be discussed in this section.

A clutch in an automotive vehicle (Fig. 5) provides a means of connecting and disconnecting the engine from the power transmission system. Since the internal combustion engine does not develop a high starting torque, it must be disconnected from the power train and allowed to operate without load until it develops enough torque to overcome the inertial of the vehicle when starting from rest. The application of the engine power to the load must be gradual to provide smooth engagement and to lessen the shock on the driving parts. After engagement, the clutch must transmit all the engine power to the transmission without slipping. Further, it is desirable to disconnect the engine from the power train during the time the gears in the transmission are being shifted from one gear ration to another.

The transmission of power through the clutch is accomplished by bringing one or more rotating drive members secured to the crankshaft into gradual contact with one or more driven members secured to the unit being driven. These members are either stationary or rotating at different speeds. Contact is established and maintained by strong spring pressure controlled by the driver through the clutch pedal and suitable linkage. As spring pressure increases, the friction increases; therefore, when the pressure is light, the comparatively small amount of friction between the members permits a great deal of slippage. As the spring pressure increases, less slippage occurs until, when the full spring pressure is applied, the speed of the driving and driven members is the same. All slipping has stopped and there is, in effect, a direct connection between the driving and driven parts.

### CLUTCH COMPONENTS

The principal parts of a clutch are: the driving members, attached to the engine and turning with it; the driven members attached to the transmission and turning with it; the operating members which include the spring or springs and the linkage required to apply and release the pressure which holds the driving and driven members in contact with each other. Figure 6 shows a clutch cutaway so operating members can be seen.

#### Driving Members

The driving members of a clutch usually consist of two nodular iron plates or flat surfaces machined and ground to a smooth finish. Nodular iron is desirable because it contains enough graphite to provide some lubrication when the driving member is slipping during engagement. One of these surfaces is usually the rear face of the engine flywheel, and the other is a comparatively heavy flat ring with one side machined flat and smooth. This part is known as the pressure plate. It is fitted into a steel cover, which also contains some of the operating members, and is bolted to the flywheel.

#### Driven Members

The driven member is a disc with a splined hub which is free to slide lengthwise along the splines of the clutch shaft, but which drives the shaft through these same splines. Grooves on both sides of the clutch driven plate lining prevent sticking of the plate to the flywheel and pressure plate due to vacuum between the members on disengaging. The clutch driven plate (Fig. 7) is usually made of spring steel in the shape of a single flat disc consisting of a number of flat segments. Suitable frictional facings are attached to each side of the plate by means of brass rivets. These facings must be heat resistant since friction produces heat. The most commonly used facings are made of cotton and asbestos fibers woven or molded together and impregnated with resins or similar binding agents. Very often, copper wires are woven or pressed into material to give it additional strength.

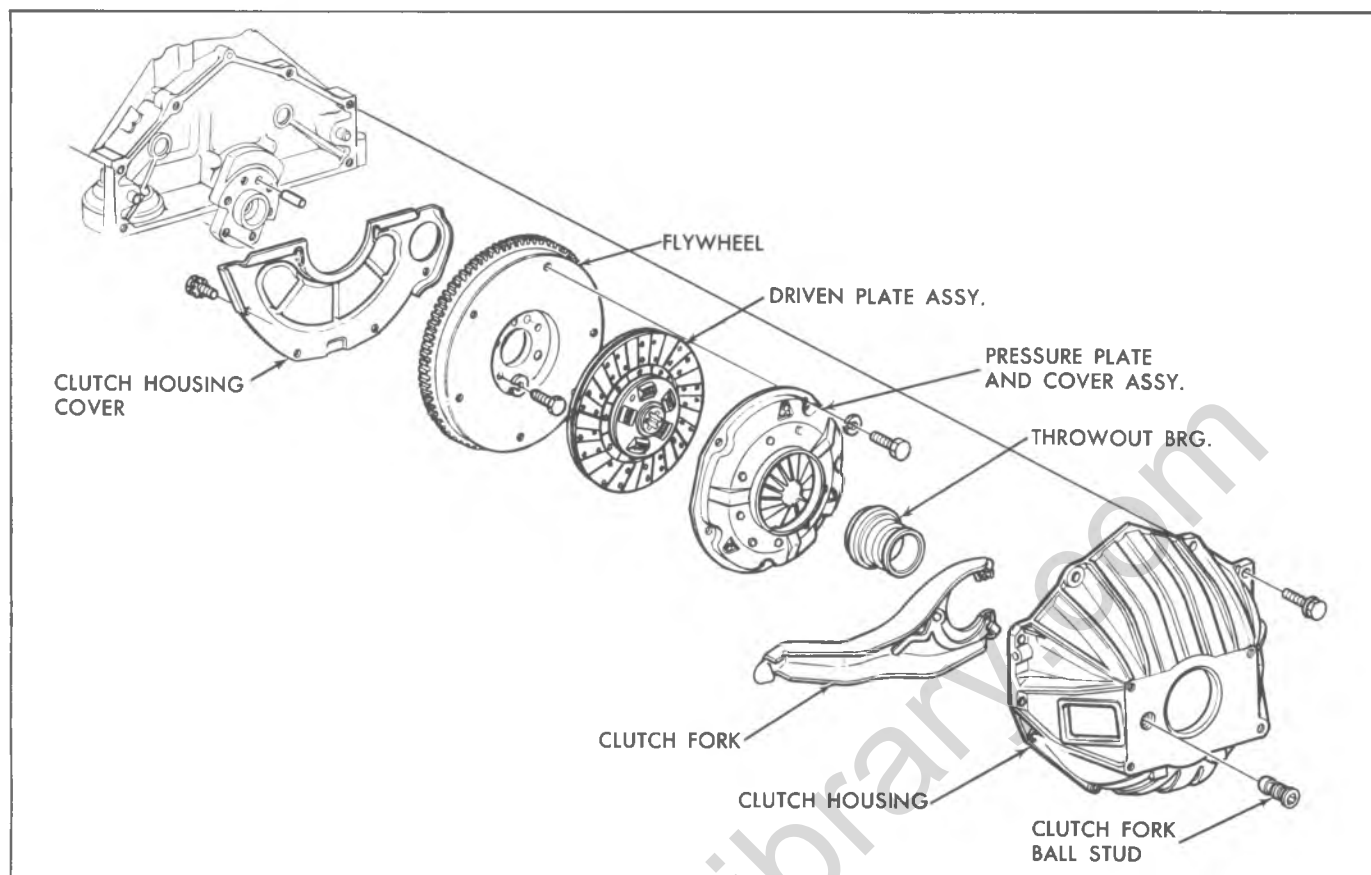

Fig. 5—Exploded View of Clutch and Flywheel Assembly

In order to make clutch engagement as smooth as possible and eliminate chatter, the steel segments attached to the splined hub are slightly waved, which also causes the facings to make gradual contact as the waved springs flatten out.

The driven member of the clutch (fig. 7) is usually provided with a flexible center to absorb the torsional vibration of the crankshaft which would be transmitted to the power train unless it were eliminated. The flexible center usually takes the form of steel compression springs placed between the hub and the steel plate. The springs permit the plate to rotate slightly with relation to its hub. Then the plate can rotate slightly backward as the springs decompress. This slight backward and forward rotation permitted by the springs allows the clutch shaft to rotate at a more uniform rate than the crankshaft, thereby eliminating some of the torsional vibration from the crankshaft and preventing the vibration from being carried back through the transmission.

### Operating Members

The driving and driven members are held in contact by spring pressure. This pressure may be exerted by a one-piece conical or diaphragm spring (fig. 6) or; a number of small helical springs located circumferentially around

the outer portion of the pressure plate (fig. 8). In the diaphragm design clutch, the throwout bearing moves forward against the spring fingers forcing the diaphragm spring to pivot around the inner pivot ring, dishing the fingers toward the flywheel. The outer circumference of the spring now lifts the pressure plate away from the driven disc, through a series of retracting springs placed around the outer circumference of the pressure plate. In the helical-spring clutch a system of levers pivoted on the cover forces the pressure plate away from the driven disc and against the pressure of the springs thus performing the same function as the dish-shaped diaphragm spring.

**NOTE:** Two variations of the diaphragm spring design are the flat finger type and the bent finger type (fig. 6). The integral release fingers in the bent finger design are bent back to gain a centrifugal boost to aid quick re-engagement at high engine speeds. This design is used primarily with V-8 engines and passenger car heavy duty clutch assemblies.

The clutch release or (throw-out) bearing is a ball-thrust bearing contained in the clutch housing, mounted on a sleeve attached to the front of the transmission case. The release bearing is connected through linkage to the clutch, and is moved by the release fork to engage the release levers and move the pressure plate to the rear,

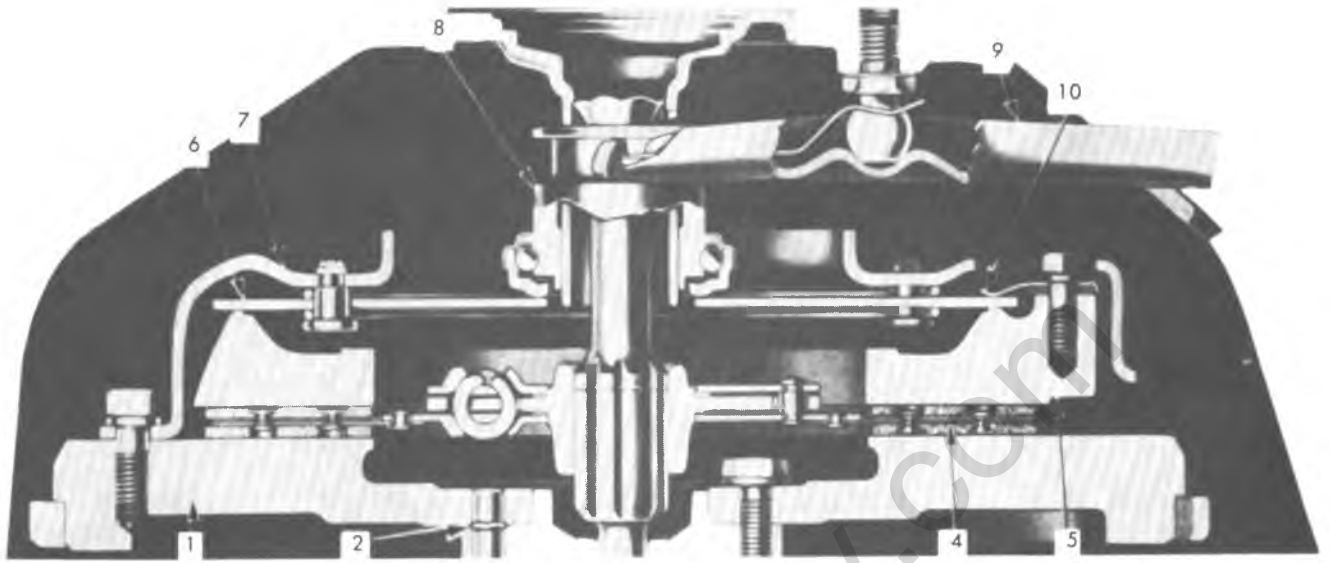

FLAT FINGER

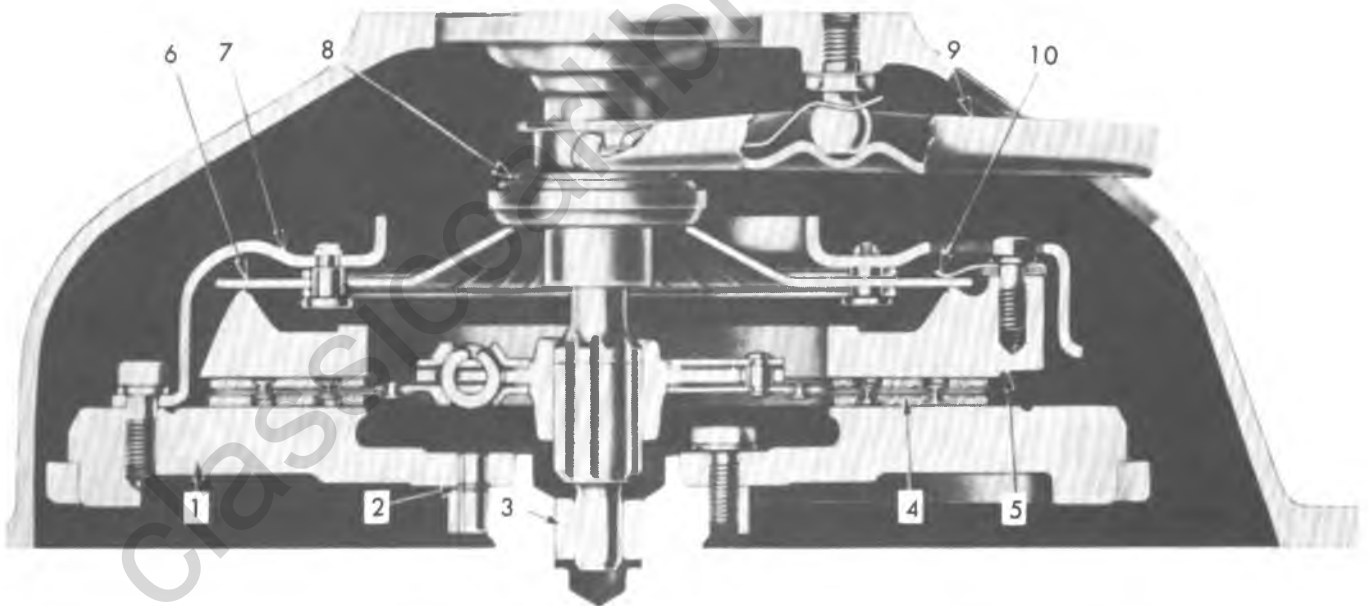

BENT FINGER

- |               |                  |                     |                     |                       |
|---------------|------------------|---------------------|---------------------|-----------------------|
| 1. Flywheel   | 3. Pilot Bushing | 5. Pressure Plate   | 7. Cover            | 9. Fork               |
| 2. Dowel-hole | 4. Driven Disc   | 6. Diaphragm Spring | 8. Throwout Bearing | 10. Retracting Spring |

Fig. 6—Diaphragm Spring Clutch Cross-section (Typical)

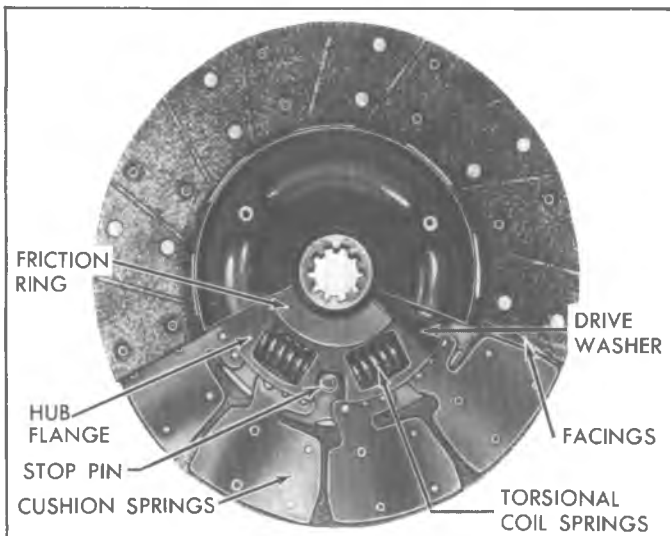

Fig. 7—Clutch Driven Plate Assembly

thus separating the clutch driving members from the driven member when the clutch pedal is depressed by the driver. A return spring preloads clutch linkage, removing looseness due to wear. The clutch free pedal travel, therefore, will increase with linkage wear and decrease with driven disc wear and the free travel felt at the clutch pedal is throwout bearing lash.

NOTE: The clutch release bearing used with the bent finger design is of shorter length than the release bearing used with the flat finger design clutch. Do not interchange the two bearings. The longer bearing, if used with the bent finger spring clutch, will cause inability to obtain free pedal travel, resulting in slippage and rapid wear.

## CLUTCH OPERATION

### Diaphragm Clutch

In diaphragm spring type clutches, a diaphragm is used instead of coil springs. It is a conical piece of spring steel punched to give it greater flexibility. The diaphragm is positioned between the cover and the pressure plate so that the diaphragm spring is nearly flat when the clutch is in the engaged position. The action of this type of spring is similar to that of the bottom of an ordinary oil can. The pressure of the outer rim of the spring on the pressure plate decreases as the flat position is passed. The outer rim of the diaphragm is secured to the pressure plate and is pivoted on rings approximately 1 inch in from the outer edge so that the application of the pressure at the inner section will cause the outer rim to move away from the flywheel and draw the pressure plate away from the clutch disc, releasing or disengaging the clutch. When the pressure is released from the inner section, the oil-can action of the diaphragm causes the inner section to move out, and the movement of the outer rim forces the pressure plate against the clutch disc, thus engaging the clutch.

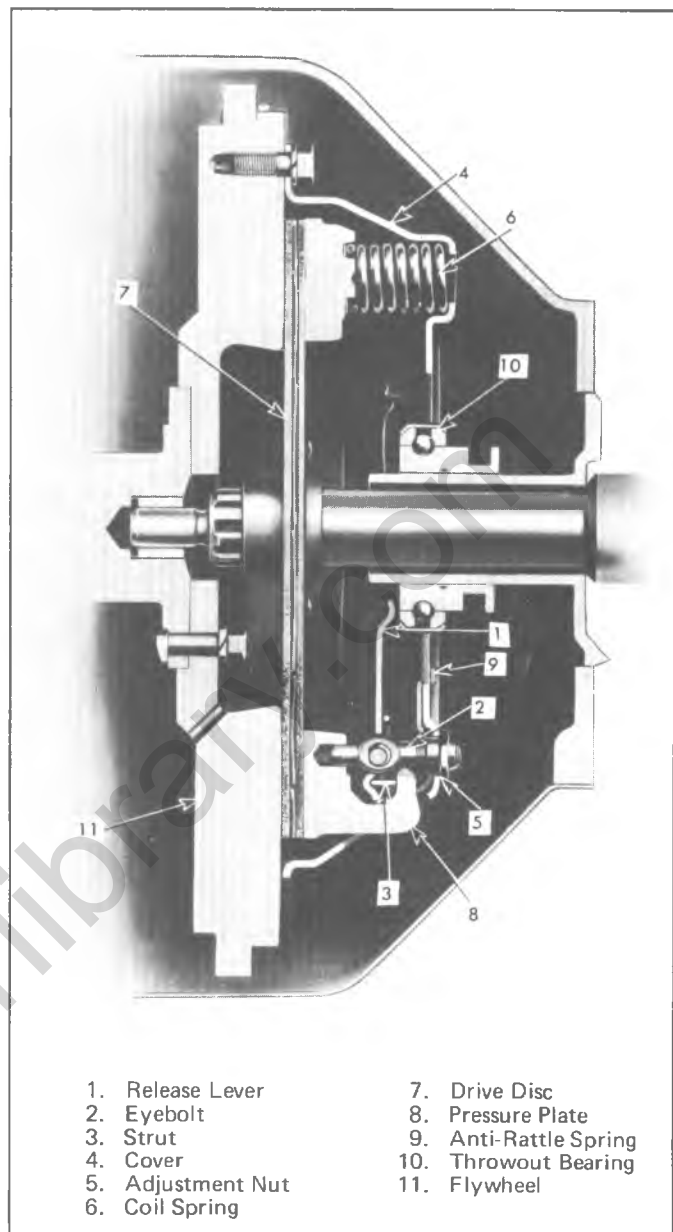

Fig. 8—Coil Spring Clutch Cross-section

### Coil Spring Clutch

In some clutches, coil springs are used instead of a diaphragm spring. This type of clutch (fig. 8) operates as follows:

When the clutch is fully engaged, the driven disc is firmly clamped between the flywheel and the pressure plate by the pressure of the springs. When the driver disengages the clutch by depressing the pedal, the release fork is moved on its pivot, and the pressure is applied to the release bearing. The rotating race of the release bearing presses against the clutch release levers and moves them on their pivot pins. The outer ends of the release levers, being fastened to the cover, move the pressure plate to the rear, compressing the clutch springs and allowing driving members to rotate independently of the driven member. The release fork moves only on

its pivot, which contacts the clutch fork ball stud. All parts of the clutch, except the release bearing and collar, rotate with the flywheel when the clutch is engaged.

When the clutch is disengaged, the release bearing rotates with the flywheel, but the driven plate and the clutch shaft. Rotate as dictated by the transmission gear range and vehicle speed.

## SERVICE OPERATIONS

### PRELIMINARY INSPECTION

There are many things which affect good clutch operation. Therefore, it is necessary, before performing any major clutch operations, to make a preliminary inspection to determine whether or not the trouble is actually in the clutch.

1. Check the clutch pedal and make sure that the pedal has at least 3/4"-1" free travel.
2. Check the clutch pedal bushing for wear and for sticking on the shaft or loose mountings.
3. Lubricate the pedal linkage.
4. Tighten all front and rear engine mounting bolts. Should the mountings be oil soaked, it will be necessary to replace them.

### CLUTCH REPLACEMENT

#### Removal From Vehicle

1. Remove transmission as outlined in "Transmission Section."
2. Disconnect clutch fork push rod and pull back spring.
3. Remove clutch and flywheel housing.
4. Remove clutch fork by pressing it away from its ball mounting with a screwdriver, until the fork snaps loose from the ball or remove ball stud from rear of clutch housing. Remove throwout bearing from clutch fork.

**NOTE:** The retainer may be removed from the fork by prying out with a small screwdriver.

5. Install Tool J-5824 or a used clutch drive gear to support the clutch assembly during removal.

**NOTE:** Before removing clutch from flywheel, mark the flywheel, clutch cover and one pressure plate lug, so that these parts may be assembled in their same relative positions, as they were balanced as an assembly.

6. Loosen the clutch attaching bolts one turn at a time to prevent distortion of clutch cover until diaphragm spring is released.
7. Remove clutch pilot tool and remove clutch assembly from vehicle.

**NOTE:** The flywheel should be inspected for cracks, heat checking, flatness and other defects.

#### Installation to Vehicle

1. Install the pressure plate in the cover assembly lining up the notch mark on pressure plate with notch mark on flange of cover.
2. Install pressure plate retracting springs, lockwashers and drive strap to pressure plate bolts. Tighten to 11 ft. lbs. torque. The clutch is now ready to be installed.
3. Hand crank the engine until "X" mark on flywheel is at the bottom.
4. Install clutch disc, pressure plate and cover assembly and support them with Tool J-5824 or a used clutch drive gear.
5. Turn clutch assembly until "X" mark or painted white letter on clutch cover flange lines up with "X" mark on flywheel.
6. Install attaching bolts and tighten each one a turn at a time to prevent distorting the cover as the spring pressure is taken up.
7. Remove clutch pilot Tool.

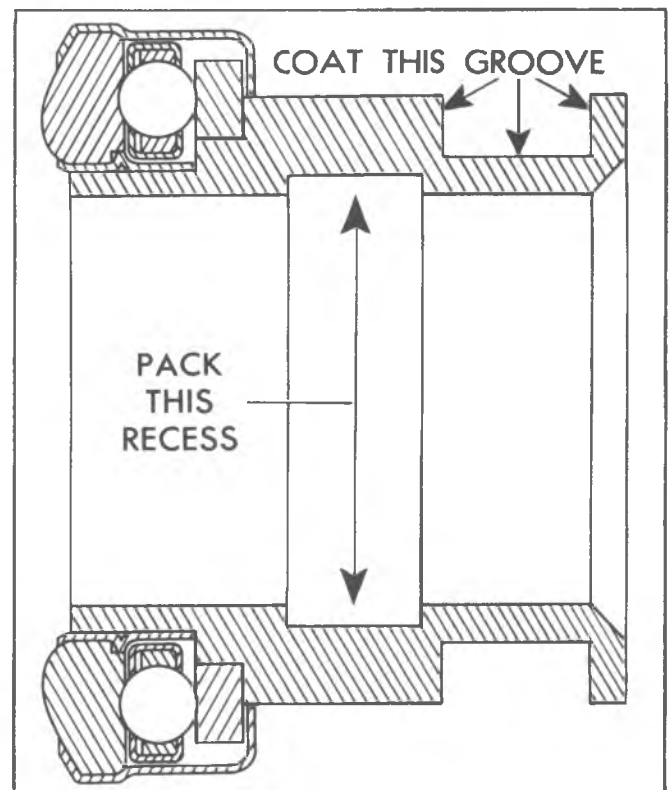

Fig. 9—Lubrication Points on Clutch Throwout Bearing

## 7M-14 CLUTCHES & MANUAL TRANSMISSIONS

8. Pack clutch fork ball seat with a small amount of high melting point grease. On "P" models with J76, install a new retainer in the groove of the clutch fork if the old retainer is worn or damaged.

NOTE: Install retainer with high side up, away from bottom of the ball socket and with open end of retainer on the horizontal.

**CAUTION:** Be careful not to use too much lubricant. Excessive lubricant may get on clutch fingers and cause slippage.

9. Replace clutch fork ball if removed from the clutch housing and snap clutch fork onto the ball.

10. Pack lubricant in the recess on the inside of the throwout bearing collar and coat the throwout fork groove with a small amount of graphite grease (fig. 9).
11. Install throwout bearing assembly to the throwout fork. Install clutch and flywheel housing to engine.
12. Assemble transmission as outlined in Transmission Section,
13. Align push rod to clutch fork and attach return spring to clutch fork.
14. Adjust clutch linkage (See adjustments in this section).

## COIL SPRING CLUTCH

### INDEX

General Description .....	7M-14	Service Operations .....	7M-14
Theory of Operation (Refer to Diaphragm Clutch).....	7M-9	Clutch Assembly Replacement.....	7M-14

### GENERAL DESCRIPTION

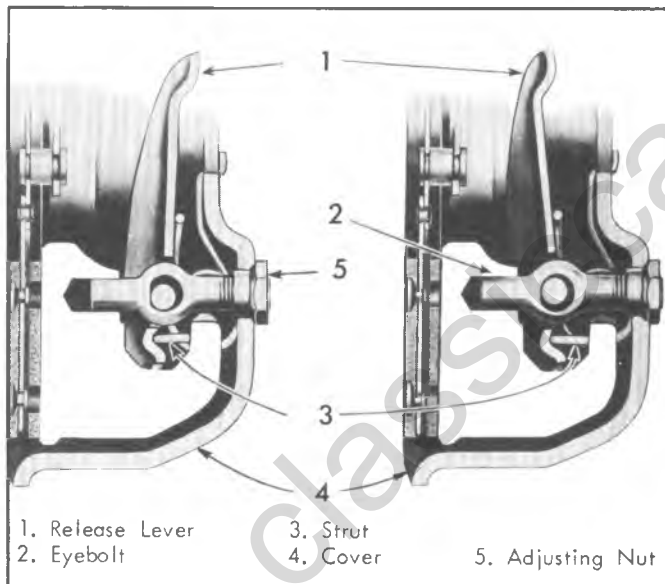

Fig. 10—Release Lever

The coil spring single plate clutch (Fig. 8) is a dry disc type and no adjustment for wear is provided in the clutch itself. An individual adjustment is provided for locating each lever in manufacturing but the adjusting nut is locked in place and should never be disturbed, unless the clutch is dismantled for replacement of parts.

When the clutch pedal is depressed the release bearing is moved toward the flywheel and contacts the inner ends of the release levers, (1) (fig. 10). Each release lever is pivoted on a floating pin which remains stationary in the lever and rolls across a short flat portion of the enlarged hole in the eyebolt (2). The outer end of each release lever engages the pressure plate lug by means of a strut (3), which provides knife-edge contact between the outer end of the lever and the lug. The outer ends of the eyebolts extend through holes in the stamped cover (4), and are fitted with adjusting nuts (5) to correctly position the levers.

### SERVICE OPERATIONS

#### CLUTCH ASSEMBLY REPLACEMENT

##### Removal From Vehicle

1. Remove transmission as outlined in "Transmission Section."

2. Disconnect clutch fork push rod and pull back spring.
3. Remove clutch and flywheel housing.
4. Remove clutch fork by pressing it away from its

ball mounting with a screwdriver, until the fork snaps loose from the ball or remove ball stud from rear of clutch housing. Remove throwout bearing from clutch fork.

**NOTE:** The retainer may be removed from the fork by prying out with a small screwdriver.

5. Install Tool J-5824 or a used clutch drive gear to support the clutch assembly during removal.

**NOTE:** Before removing clutch from flywheel, mark the flywheel, clutch cover and one pressure plate lug, so that these parts may be assembled in their same relative positions, as they were balanced as an assembly.

6. Loosen the holding screws a turn or two at a time to avoid bending rim of cover. It is advantageous to place wood or metal spacers (approximately 3/8 thick) between the clutch levers and the cover to hold the levers down as the holding screws are removed or when clutch is removed from engine. When removing driven plate be sure to mark flywheel side.
7. Remove clutch pilot tool and remove clutch assembly from vehicle.

**NOTE:** Inspect flywheel for heat defects, cracks, flatness, or other defects.

### Installation To Vehicle

1. Assemble driven plate and clutch cover assembly to flywheel in accordance with marking on driven plate for flywheel side. Use Tool J-5824 or a dummy shaft to support assembly.

2. Line up the clutch assembly with "X" mark or painted white letter with "X" mark on flywheel, before tightening cover holding screws.
3. Tighten holding screws, a turn at a time, before removing dummy shaft.
4. Remove clutch pilot tool.
5. Pack clutch fork ball seat with a small amount of high melting point grease and install a new retainer in the groove of the clutch fork if the old retainer is worn or damaged.

**NOTE:** Install retainer with high side up, away from bottom of the ball socket and with open end of retainer on the horizontal.

**CAUTION:** *Be careful not to use too much lubricant. Excessive lubricant may get on clutch fingers and cause slippage.*

6. Replace clutch fork ball if removed from the clutch housing and snap clutch fork onto the ball.
7. Pack lubricant in the recess on the inside of the throwout bearing collar and coat the throwout fork groove with a small amount of graphite grease (fig. 9).
8. Install throwout bearing assembly to the throwout fork. Install clutch and flywheel housing to engine.
9. Assemble transmission as outlined in Transmission Section,
10. Align push rod to clutch fork and attach return spring to clutch fork.
11. Adjust clutch linkage (See adjustments in this section).

## CLUTCH TROUBLE DIAGNOSIS

CONDITION	PROBABLE CAUSE	CORRECTION
Fails to Release (Pedal pressed to floor-shift lever does not move freely in and out of reverse gear)	<ul style="list-style-type: none"> <li>a. Improper linkage Adjustment</li> <li>b. Improper pedal travel</li> <li>c. Loose linkage</li> <li>d. Faulty pilot bearing</li> <li>e. Faulty driven disc</li> <li>f. Fork off ball stud</li>   <li>g. Clutch disc hub binding on clutch gear spline</li> <li>h. Clutch disc warped or bent</li> </ul>	<ul style="list-style-type: none"> <li>a. Adjust Linkage</li> <li>b. Trim bumper stop and adjust linkage</li> <li>c. Replace as necessary</li> <li>d. Replace bearing</li> <li>e. Replace disc</li> <li>f. Install properly and* lubricate fingers at throw-out bearing with wheel bearing grease.</li> <li>g. Repair or replace clutch gear and/or disc.</li> <li>h. Replace disc (run-out should not exceed .020").</li> </ul> <p>*Very lightly lubricate fingers</p>
Slipping	<ul style="list-style-type: none"> <li>a. Improper Adjustment (no lash)</li> <li>b. Oil Soaked driven disc</li>   <li>c. Worn facing or facing torn from disc.</li> <li>d. Warped pressure plate or flywheel</li> <li>e. Weak diaphragm spring</li>   <li>f. Driven plate not seated in</li> <li>g. Driven plate overheated</li> </ul>	<ul style="list-style-type: none"> <li>a. Adjust linkage to spec.</li> <li>b. Install new disc and correct leak at its source</li> <li>c. Replace disc</li> <li>d. Replace pressure plate or flywheel</li> <li>e. Replace pressure plate (Be sure lash is checked before replacing plate.)</li> <li>f. Make 30 to 40 normal starts</li> <li>CAUTION: Do Not Overheat</li> <li>g. Allow to cool – check lash</li> </ul>
Grabbing (Chattering)	<ul style="list-style-type: none"> <li>a. Oil on facing. Burned or glazed facings.</li> <li>b. Worn splines on clutch gear.</li> <li>c. Loose engine mountings.</li> <li>d. Warped pressure plate or flywheel.</li> <li>e. Burned or smeared resin on flywheel or pressure plate.</li> </ul>	<ul style="list-style-type: none"> <li>a. Install new disc and correct leak.</li>   <li>b. Replace transmission clutch gear.</li> <li>c. Tighten or replace mountings.</li> <li>d. Replace pressure plate or flywheel.</li> <li>e. Sand off if superficial, replace burned or heat checked parts.</li> </ul>
Rattling-Transmission Click	<ul style="list-style-type: none"> <li>a. Weak retracting springs.</li> <li>b. Throw-out fork loose on ball stud or in bearing groove.</li> <li>c. Oil in driven plate damper.</li> <li>d. Driven plate damper spring failure.</li> </ul>	<ul style="list-style-type: none"> <li>a. Replace pressure plate.</li> <li>b. Check ball stud and retaining.</li>   <li>c. Replace driven disc.</li> <li>d. Replace driven disc.</li> </ul>
Throw-Out Bearing Noise with Clutch Fully Engaged	<ul style="list-style-type: none"> <li>a. Improper adjustment. No Lash.</li> <li>b. Throw-out bearing binding on transmission bearing retainer.</li> <li>c. Insufficient tension between clutch fork spring and ball stud.</li> <li>d. Fork improperly installed.</li> <li>e. Weak linkage return spring.</li> </ul>	<ul style="list-style-type: none"> <li>a. Adjust linkage.</li> <li>b. Clean, relubricate, check for burrs, nicks, etc.</li> <li>c. Replace fork.</li>   <li>d. Install properly.</li> <li>e. Replace spring.</li> </ul>
Noisy	<ul style="list-style-type: none"> <li>a. Worn throw-out bearing.</li> <li>b. Fork off ball stud (heavy clicking).</li>   <li>c. Pilot Bearing loose in crankshaft.</li> </ul>	<ul style="list-style-type: none"> <li>a. Replace bearing.</li> <li>b. Install properly and lubricate fork fingers at bearing.</li> <li>c. See Section 6 for bearing fits.</li> </ul>
Pedal Stays on Floor When Disengaged	<ul style="list-style-type: none"> <li>a. Bind in linkage or release bearing.</li>   <li>b. Springs weak in pressure plate.</li> <li>c. Springs being over traveled.</li> </ul>	<ul style="list-style-type: none"> <li>a. Lubricate and free up linkage and release bearing.</li> <li>b. Replace pressure plate.</li> <li>c. Adjust linkage to get proper lash, be sure proper pedal stop (bumper) is installed.</li> </ul>
Hard Pedal Effort	<ul style="list-style-type: none"> <li>a. Bind in linkage.</li> <li>b. Driven plate worn.</li> </ul>	<ul style="list-style-type: none"> <li>a. Lubricate and free up linkage.</li> <li>b. Replace driven plate.</li> </ul>



# MANUAL TRANSMISSIONS

## INDEX

General Description .....	7M-17	Floor Shift Control Lever Replacement.....	7M-29
Theory of Operation.....	7M-21	Transmission Replacement.....	7M-29
Synchronizing Mechanism .....	7M-21	Transmission Alignment.....	7M-33
Synchronizing Operation.....	7M-22	Rear Oil Seal Replacement.....	7M-34
Power Flow.....	7M-24	Speedometer Driven Gear Replacement.....	7M-35
Service Operations .....	7M-28	Side Cover Replacement/Repair.....	7M-35
Linkage Adjustment .....	7M-28	Transfer Case Replacement .....	7M-35
		Diagnosis .....	7M-41

## GENERAL DESCRIPTION

The three speed synchromesh transmissions used by GM (Fig. 11 and 12) are representative of a constant-mesh transmission design. Fundamental components of these units are the case, which houses the gears and shaft; the control cover, which houses the shifter mechanism; and the various shafts and gears. The input shaft has an integral main drive gear and rotates with the clutch driven plate; that is, the shaft rotates all the time the clutch is engaged and the engine is running. The input shaft is supported in the case by a ball bearing and at the front end by an oil impregnated bushing mounted in the engine crankshaft. The drive gear is in constant mesh with the countershaft drive gear. Since all gears in the countershaft cluster are integral to the shaft, they also rotate at the time the clutch is engaged. The countergear is carried on roller bearings at both ends and thrust is absorbed by thrust washers located between the countergear and thrust bosses in the case. An anti-lash plate assembly at the front face of the countergear provides a constant spring tension between the countergear and the main drive gear to reduce torsional vibrations. The transmission mainshaft is held in line with the input shaft by a pilot bearing at its front end, which allows it to rotate or come to rest independently of the input shaft. Its carried at the rear by a ball bearing mounted in the front face of the extension housing.

Helical gears are incorporated throughout, including reverse gear. The mainshaft gears are free to rotate independently on the mainshaft and are in constant mesh with the countershaft gears. The reverse idler gear is carried on a bushing; finish bored in place, and thrust is taken on the thrust bosses of the case.

The transmissions are fully synchronized in all forward speeds, however, reverse gear is not. The synchronizer assemblies consist of a hub, sleeve, two key springs and three synchronizer keys. The synchronizer hubs are splined to the mainshaft and retained by snap rings. These assemblies permit gears to be selected without clashing, by synchronizing the speeds of mating parts before they engage. Synchronizer assemblies are discussed separately later in this section.

Four of the transmission gears are rigidly connected to the countergear. These are the driven gear, second-speed gear, first-speed gear and reverse gear. The engine driven clutch gear drives the countergear through a constant mesh countershaft driven gear. The countergear rotates in a direction opposite, or counter, to the rotation of the clutch gear. Forward speed gears on the countergear remain in constant mesh with two non-sliding mainshaft gears giving first and second speed. Third speed is a direct drive with the clutch gear engaged directly to the mainshaft. Forward gears are engaged through two sliding synchronizer sleeves mounted on the mainshaft. Engagement of the constant mesh mainshaft gears to the mainshaft is accomplished through blocker ring-type synchronizers.

NOTE: The Muncie unit is similar to the Saginaw design but differs in that it has a 3-1/4 inch center distance between the mainshaft and countershaft instead of 3 inches, and has larger bearings, gears, input shaft and mainshaft. Power flow is essentially the same for both the Saginaw and Muncie transmissions.

The Muncie Model CH 465 truck transmission (fig. 13) uses a constant mesh first gear that engages with the second speed synchronizer sleeve. Second, third and fourth gears are synchronized. Clutch gears with two different splines are used, the larger size for 40-60 series trucks. The clutch gear is supported by a heavy duty ball bearing. The forward end of the mainshaft is supported by a loose collar-type bearing inside the clutch gear, while the rear is carried on a ball bearing in the case. End play is taken up by the rear flange retaining nut. The countergear is supported at the rear by a single row ball bearing which takes the thrust load, and by a roller bearing at the front. Incorporated in the cover is a ball pin type interlock which prevents simultaneous engagement of two gears. As one rod is moved, it pushes a ball out that engages the other two rods to prevent their movement.

Gearshift levers on manual transmissions are located

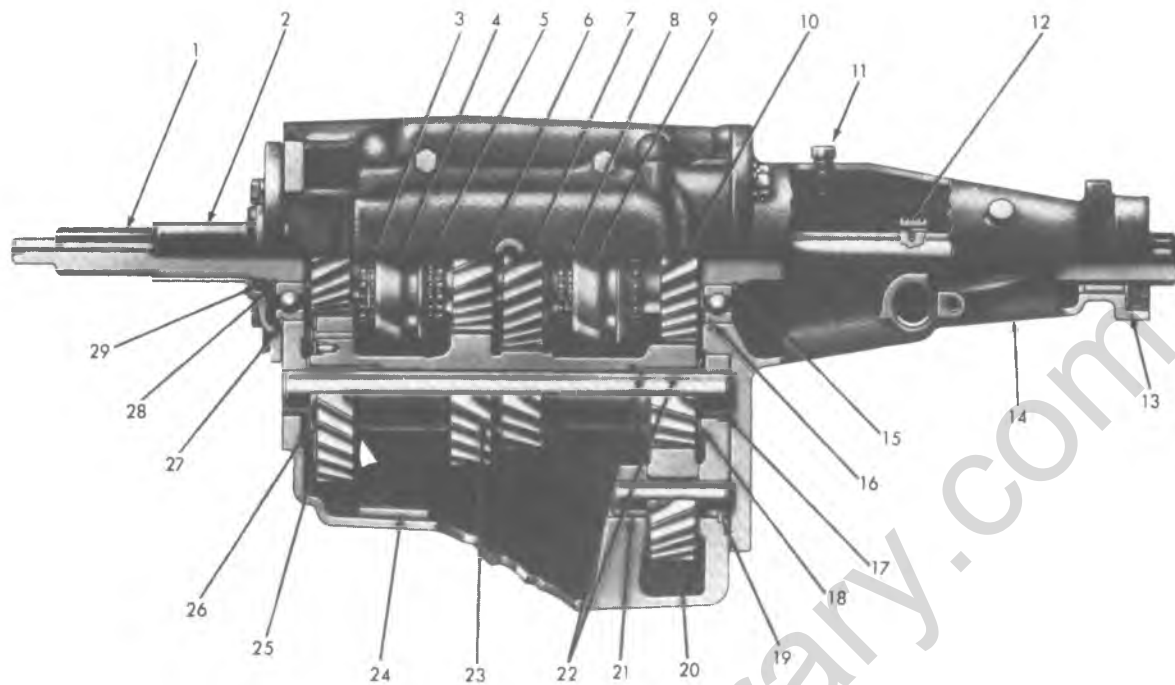

- |                                 |   |                                   |
|---------------------------------|---|-----------------------------------|
| 1. Clutch Gear                  | 11. Vent                                | 21. Reverse Idler Shaft           |
| 2. Clutch Gear Bearing Retainer | 12. Speedometer Gear and Clip           | 22. Countergear Bearings          |
| 3. 3rd Speed Synchronizer Ring  | 13. Rear Extension Seal                 | 23. Countergear                   |
| 4. 2nd-3rd Speed Clutch Assy.   | 14. Rear Extension                      | 24. Case Magnet                   |
| 5. 2nd Speed Synchronizer Ring  | 15. Rear Bearing-to-Shaft Snap Ring     | 25. Anti-Lash Plate Assy.         |
| 6. 2nd Speed Gear               | 16. Rear Bearing-to-extension Snap Ring | 26. Thrust Washer                 |
| 7. 1st Speed Gear               | 17. Countergear Woodruff Key            | 27. Clutch Gear Bearing           |
| 8. 1st Speed Synchronizer Ring  | 18. Thrust Washer                       | 28. Snap Ring                     |
| 9. 1st-Reverse Clutch Assy.     | 19. Reverse Idler Shaft Woodruff Key    | 29. Clutch Gear Retainer Lip Seal |
| 10. Reverse Gear                | 20. Reverse Idler Gear                  |                                   |

Fig. 11—Muncie 3-Speed Transmission Cross Section

either on the steering column or on the floorboard. Regardless of location, the lever performs two operations: It selects the gear assembly to be moved, and moves it either forward or backward into the desired

gear position. The transmission action is the same whether a floor-type shift lever or a steering column shift lever is used. When the shift lever is moved, the movement is carried by linkage to the transmission.

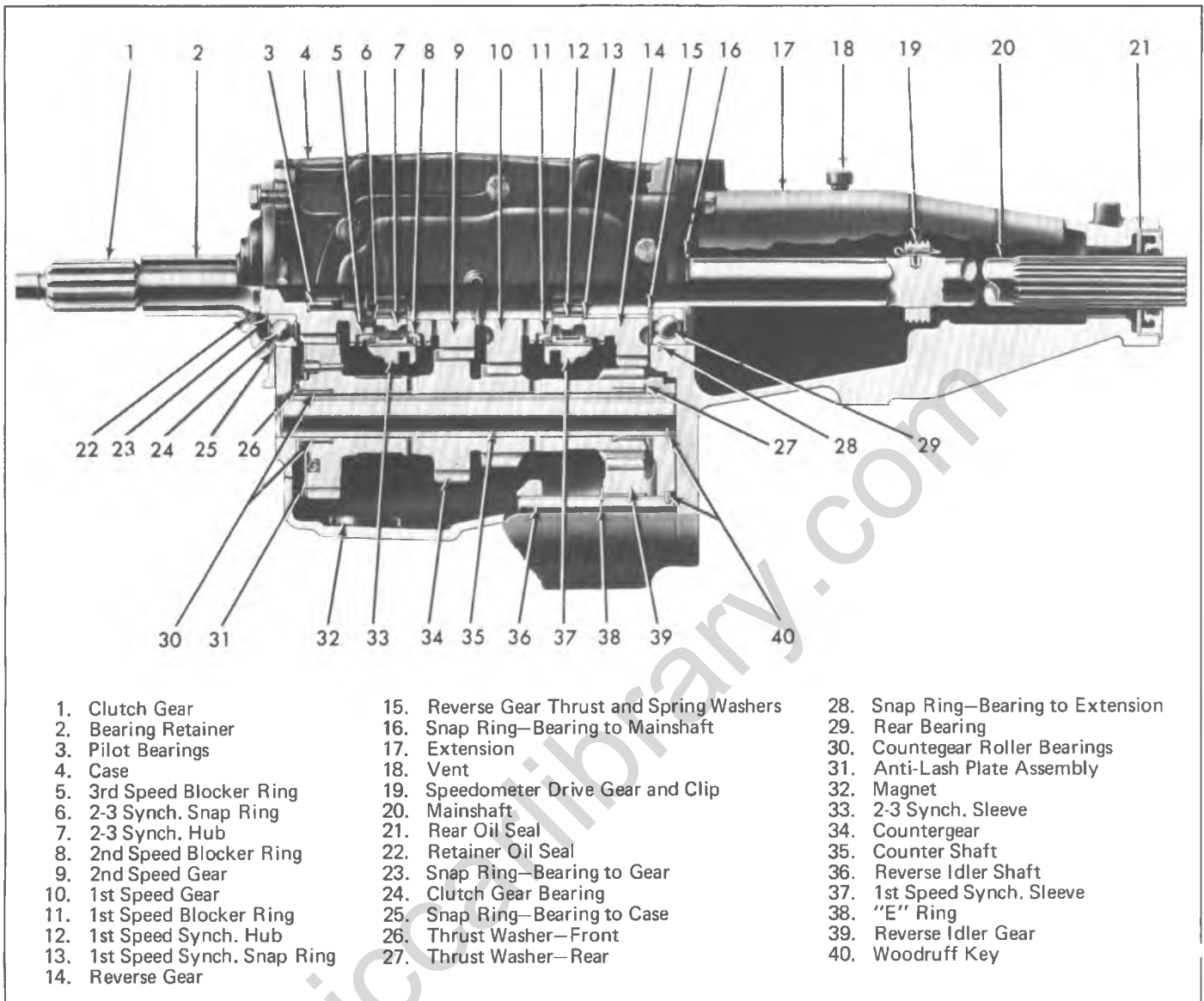
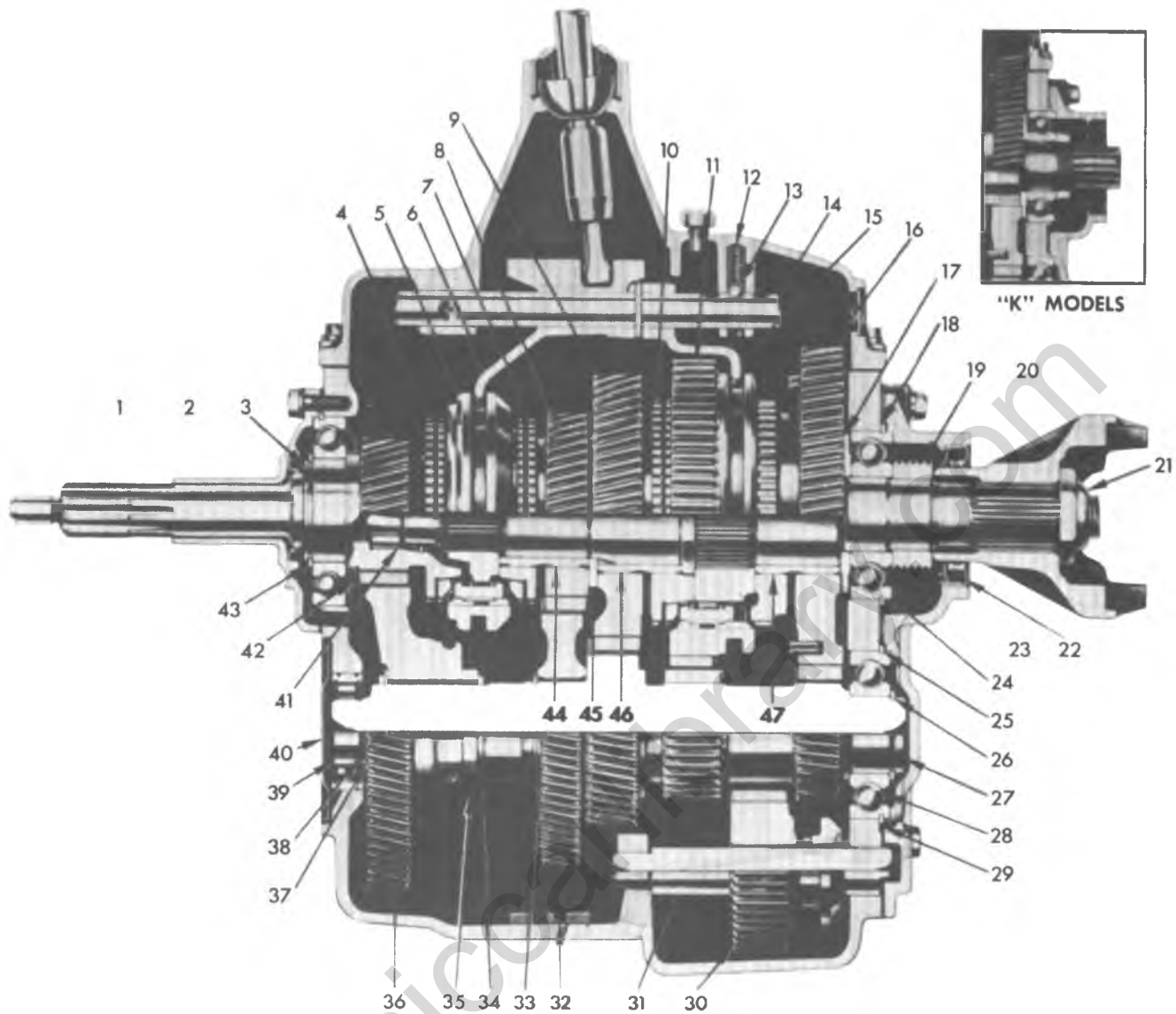

Fig. 12—Saginaw 3-Speed Transmission Cross Section



- |  |                                    |                               |                                |
|--|------------------------------------|-------------------------------|--------------------------------|
| 1. Main Drive Gear                     | 11. Reverse Driven Gear            | 24. Mainshaft Rear Bearing    | 37. Thrust Washer              |
| 2. Drive Gear Bearing Retainer         | 12. Poppet Spring                  | 25. Rear Bearing Snap Ring    | 38. Snap Ring                  |
| 3. Snap Ring-Outer                     | 13. Poppet Ball                    | 26. Snap Ring                 | 39. Front Countershaft Bearing |
| 4. 3rd and 4th Synchronizer Ring       | 14. Shift Rail                     | 27. Countershaft              | 40. Countergear Front Cover    |
| 5. 3rd and 4th Synchronizer Collar     | 15. 1st and 2nd Shift Fork         | 28. Countershaft Rear Bearing | 41. Pilot Bearing Rollers      |
| 6. 3rd and 4th Shift Fork              | 16. 1st Speed Gear                 | 29. Bearing Snap Ring         | 42. Clutch Gear Oil Slinger    |
| 7. 3rd and 4th Speed Synchronizer Ring | 17. Thrust Washer                  | 30. Reverse Idler Gear        | 43. Snap Ring                  |
| 8. 3rd Speed Gear                      | 18. Bearing Snap Ring              | 31. Reverse Idler Shaft       | 44. 3rd Speed Gear Bushing     |
| 9. 2nd Speed Gear                      | 19. Speedometer Drive Gear         | 32. Case Magnet               | 45. Thrust Washer              |
| 10. 1st and 2nd Synchronizer Assembly  | 20. Output Yoke                    | 33. Snap Ring                 | 46. 2nd Speed Gear Bushing     |
|  | 21. Flange Nut                     | 34. Snap Ring                 | 47. 1st Speed Gear Bushing     |
|  | 22. Rear Bearing Retainer Oil Seal | 35. Spacer                    |                                |
|  | 23. Rear Bearing Retainer          | 36. Countergear               |                                |

Fig. 13—Muncie 4-Speed Transmission Cross Section

## THEORY OF OPERATION

An internal combustion engine cannot develop appreciable torque at low speeds, and it develops maximum torque only at one speed. Also, the crankshaft of an engine must always rotate in the same direction. The transmission which provides a means of varying the gear ratio between the engine and rear wheels, then becomes necessary in automotive vehicles. The transmission provides the mechanical advantage that enables the engine to propel the vehicle under adverse conditions of load. It also furnishes the driver with a selection of vehicle speeds while the engine is held at speeds within the effective torque range; and allows disengaging and reversing the power flow from the engine to the wheels. In summary, the purpose of the transmission is to provide the operator with a selection of gear ratios between engine and wheels so that the vehicle can operate at best efficiency under a variety of driving conditions and loads.

### SYNCHRONIZING MECHANISM

The entire synchronizing mechanism is installed on the mainshaft and the main drive gear. First, second, third speed are all synchronized by synchronizing clutches, which act as friction clutches. Each of the gears to be synchronized - main drive gear, second speed gear, and in this example, the first speed gear (5, Fig. 14) - has a cone surface (6, Fig. 14).

Only the hub and the gear carrier (3, Fig. 15), are tightly splined to the mainshaft, while the main drive gear, 1st, and 2nd speed mainshaft gears, can revolve on the

mainshaft. Three keys (2, Fig. 15) slide in slots of the hub (3, Fig. 14), and these keys are spring-loaded by two synchronizer springs (4, Fig. 15). Between the hub and the mainshaft 1st speed gear a synchronizer ring (7, Fig. 14) is installed which, together with the cone surface, acts as a friction clutch.

The synchronizer ring (3, Fig. 15) has three slots in which the keys (4, Fig. 16) engage, and is thereby moved along with the guide unit (1, Fig. 16). The slots in the synchronizer cover are wider than the keys, so that the

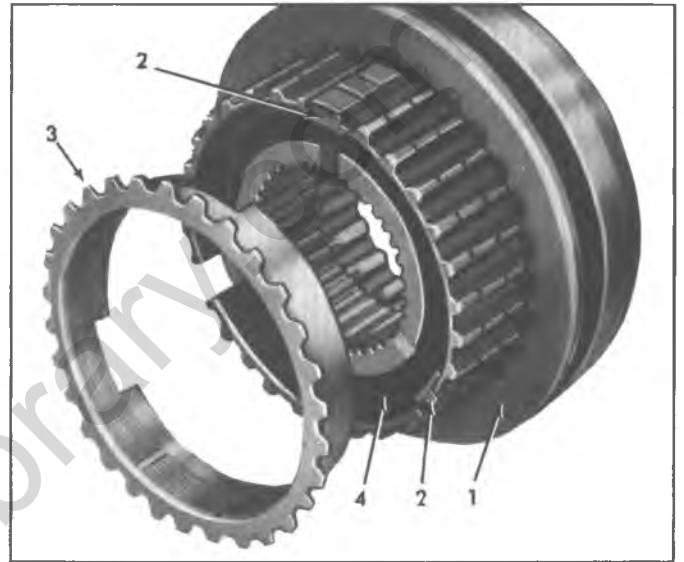

Fig. 15—Synchronizer Hub and Sleeve

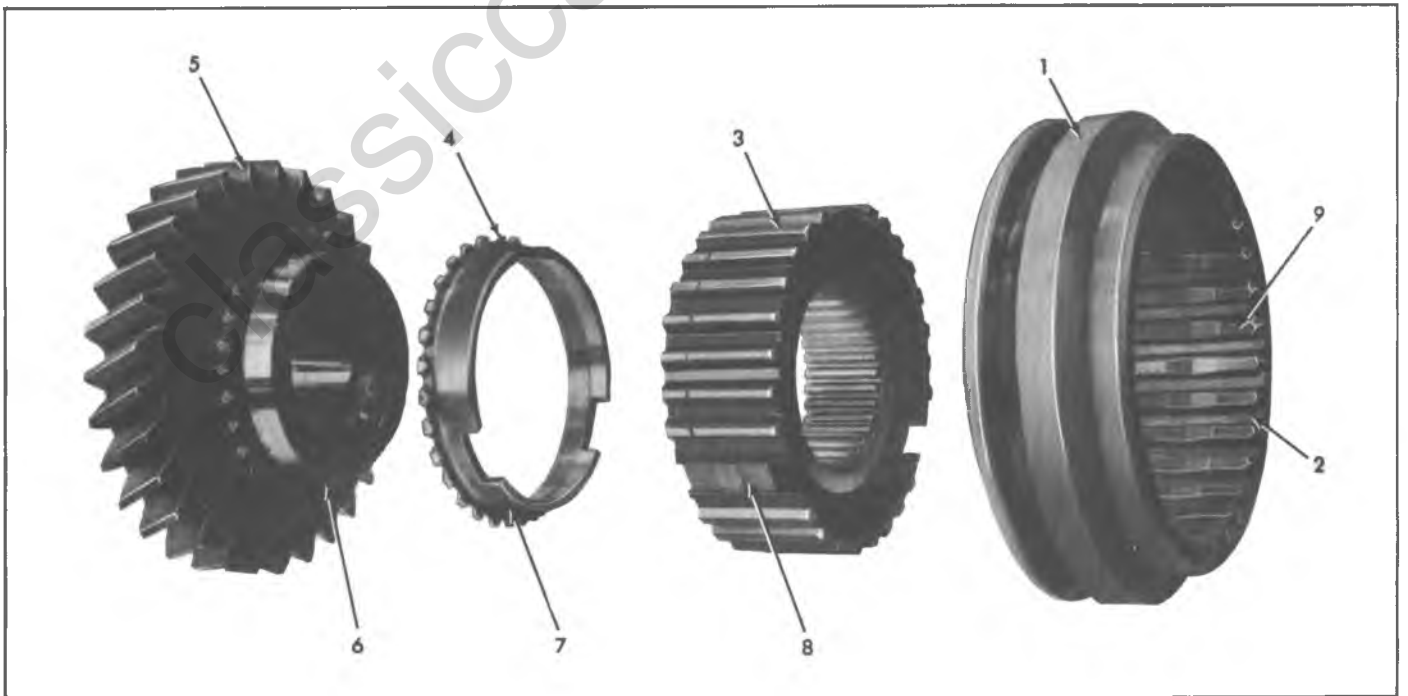

Fig. 14—Synchronizing Mechanism

## 7M-22 CLUTCHES & MANUAL TRANSMISSIONS

synchronizer ring can rotate a small amount relative to the hub.

The internally splined mainshaft 1st and reverse synchronizer sleeve (1, Fig. 14) slides along the external splines of the hub. The 1st speed gear clutch sleeve splines are recessed to form a shallow annular groove (2, Fig. 14) in which rest the raised portion of the keys (8, Fig. 14), when in neutral position. Each spline of the 1st and reverse speed gear clutch sleeve and each tooth of the synchronizer ring has on both sides a wedge angle (9 and 4, Fig. 14). Through the press of these wedge angles, the engagement of the gears is prevented until the synchronizer ring (7, Fig. 14) has brought the mainshaft 1st speed gear (5, Fig. 14) to the speed of the hub (3, Fig. 14).

### SYNCHRONIZING OPERATION

When shifting into 1st speed, the 1st and reverse synchronizer sleeve (1, Fig. 17) is moved toward the 1st speed gear. As the three keys (2, Fig. 17) are spring-loaded, they are moved along at first until they contact the synchronizer ring (3, Fig. 17) which is also moved toward the 1st speed gear (3, Fig. 17). The synchronizer ring pressing against the 1st speed gear cone causes friction and starts pre-synchronization. The friction instantly causes the synchronizer ring to turn in relation to the hub to the amount of the clearance between the keys and the sides of the synchronizer ring slots (Fig. 17). This small turning action of the synchronizer ring relative to the hub causes the wedge angles (4, Fig. 14) of the 1st and reverse synchronizer gear to press against the wedge angles (9, Fig. 14) of the synchronizer ring.

Through the movement of the 1st and reverse synchronizer sleeve to the point where the wedge angle contact is made, the keys are pressed out of the 1st and reverse synchronizer sleeve annular groove, and the action of pre-synchronization by means of the keys is ended. The necessary additional pressure for the friction clutch is now directly applied by the pressure of the wedge angles of the 1st and reverse synchronizer sleeve onto the wedge angles of the synchronizer ring. The pressure caused by this friction prevents a further engagement of the 1st and reverse synchronizer sleeve as the wedge angles of the synchronizer ring lock the wedge angles of the 1st and reverse synchronizer sleeve.

Only when the friction of the synchronizing clutch has equalized the speeds of the 1st speed gear and the hub - synchronization - friction and pressure on the synchronizer ring wedge angles are relieved.

The wedge angles of the 1st and reverse synchronizer sleeve now can push aside the synchronizer ring wedge angles allowing the 1st and reverse synchronizer sleeve splines to engage the 1st speed gear teeth (Fig. 17). The keys are now again located in the middle of the synchronizer cover slots. According to the relative speeds of the rotating hub and the gear to be synchronized either the right or the left wedge angles of the hub apply pressure onto the right or left wedge angles of the synchronizer ring.

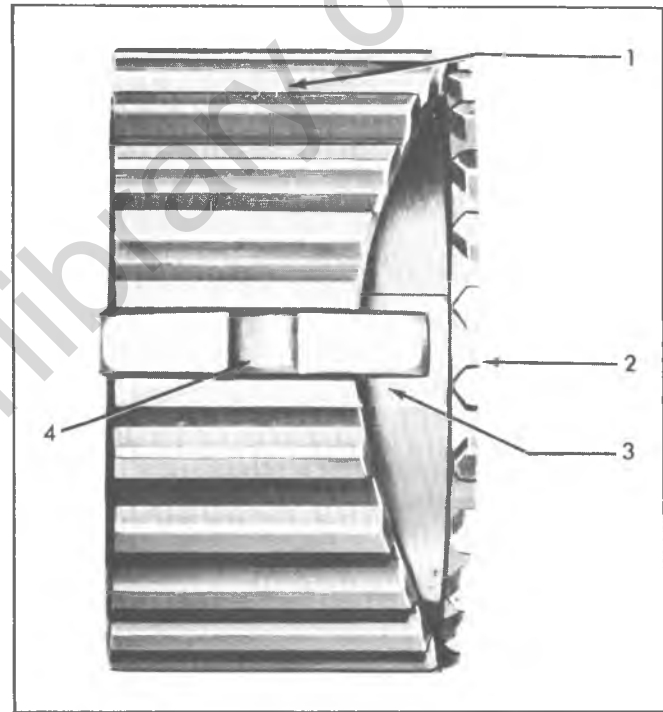

Fig. 16—Synchronizer Hub and Ring

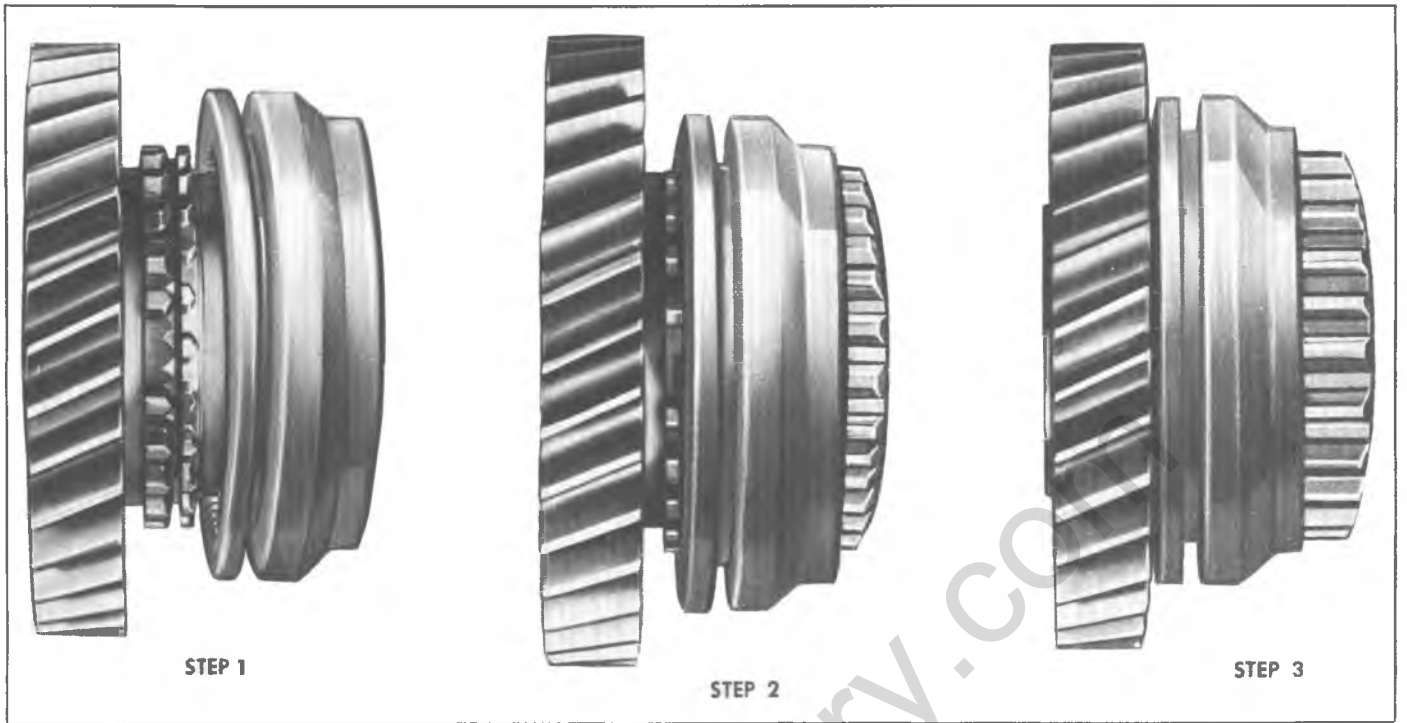

Fig. 17—Synchronizer Operation (Step 1)

classiccarrlibrary.com

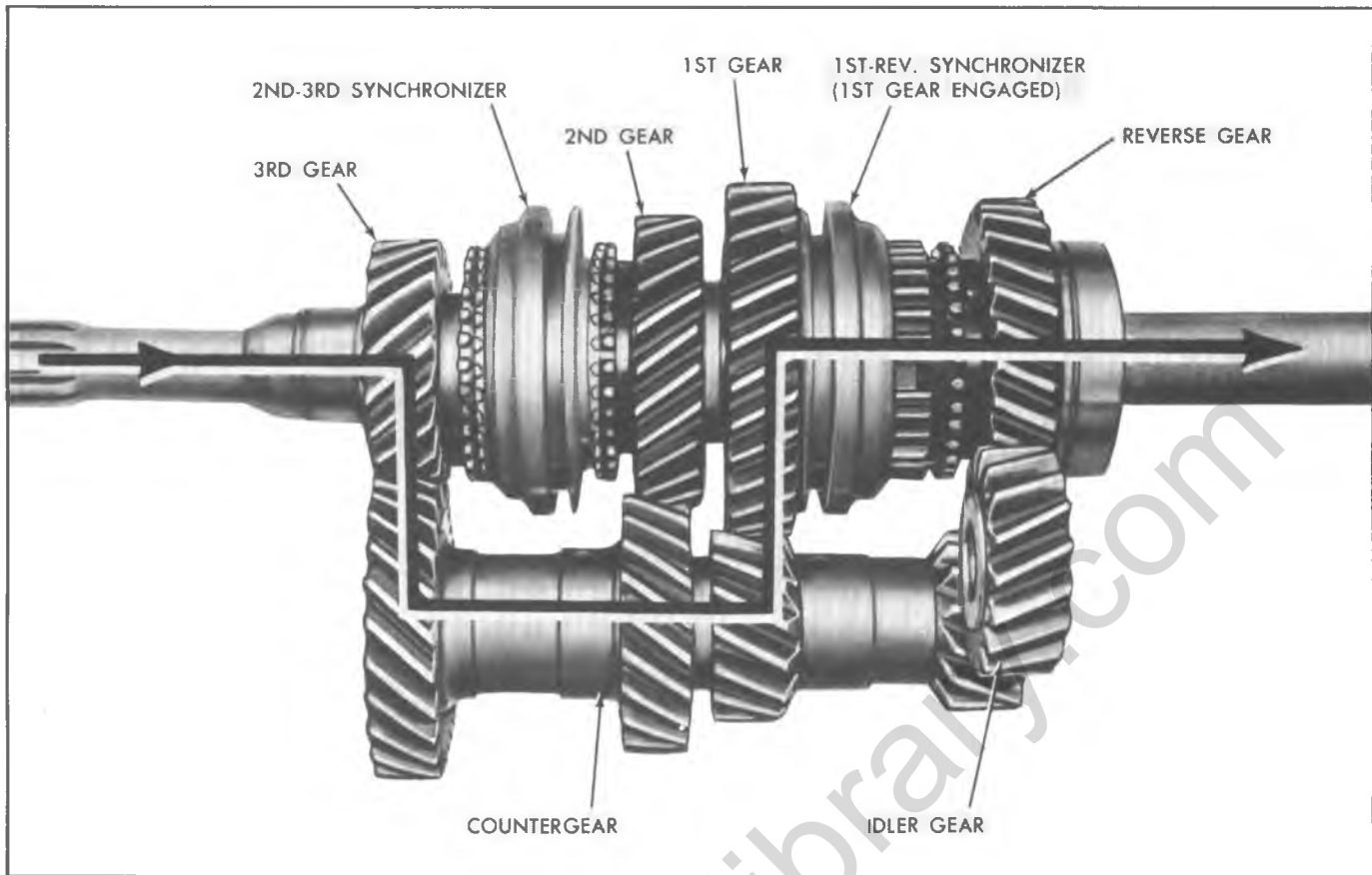

Fig. 18—Neutral Power Flow

## POWER FLOW

### Neutral (Fig. 18)

In neutral, with the engine clutch engaged, the main drive gear turns the countergear. The countergear then rotates the 2nd speed, 1st speed, and reverse idler (and reverse) gears. But, because the 2nd-3rd sliding sleeve and the 1st speed sliding sleeve are neutrally positioned, no power will flow through the mainshaft.

NOTE: The 2nd-3rd sliding sleeve is in a neutral position when it does not mesh with either the 2nd speed blocking ring and 2nd speed gear or with the 3rd speed blocking ring and main drive gear. The 1st speed sliding sleeve is in a neutral position when it does not mesh with either the 1st speed blocking ring and 1st speed gear or with the reverse gear.



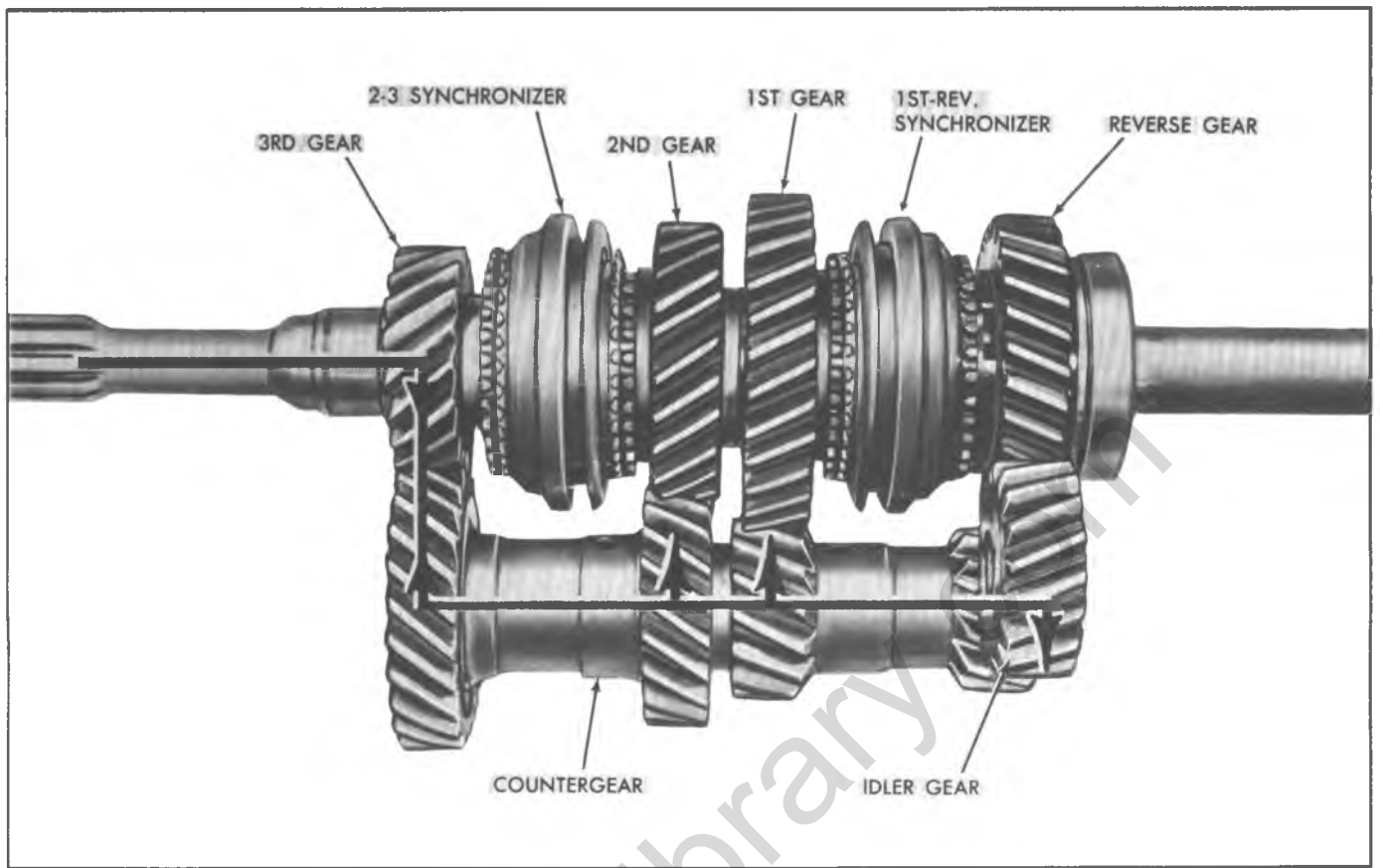

Fig. 19—First Gear Power Flow

### First Gear (Fig. 19)

In the first speed, the 1st speed sliding sleeve is moved forward to engage the 1st speed blocking ring and 1st speed gear (which is being turned by the countergear).

Because the 1st speed synchronizer hub is splined to the mainshaft, torque is imparted to the mainshaft from the 1st speed gear through the 1st speed sliding sleeve to the synchronizer hub.

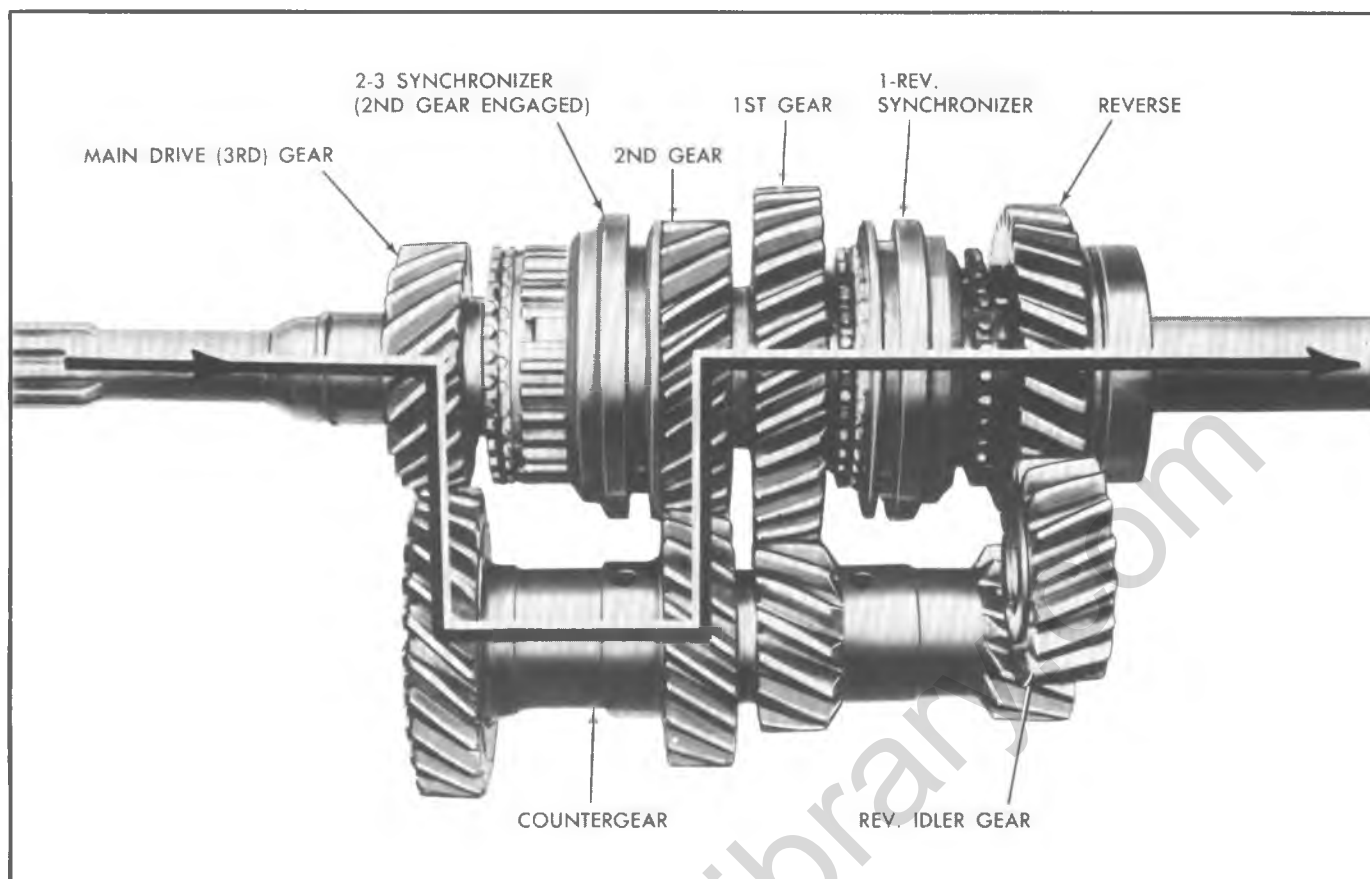

Fig. 20—Second Gear Power Flow

### Second Gear (Fig. 20)

In second speed, the 1st speed sliding sleeve assumes a neutral position. The 2nd-3rd sliding sleeve moves rearward to engage the 2nd speed blocking ring and 2nd

speed gear (which is being turned by the counter gear). Because the 2nd-3rd speed synchronizer hub is splined to the mainshaft, torque is imparted to the mainshaft from the 2nd speed gear through the 2nd-3rd sliding sleeve to the synchronizer hub.

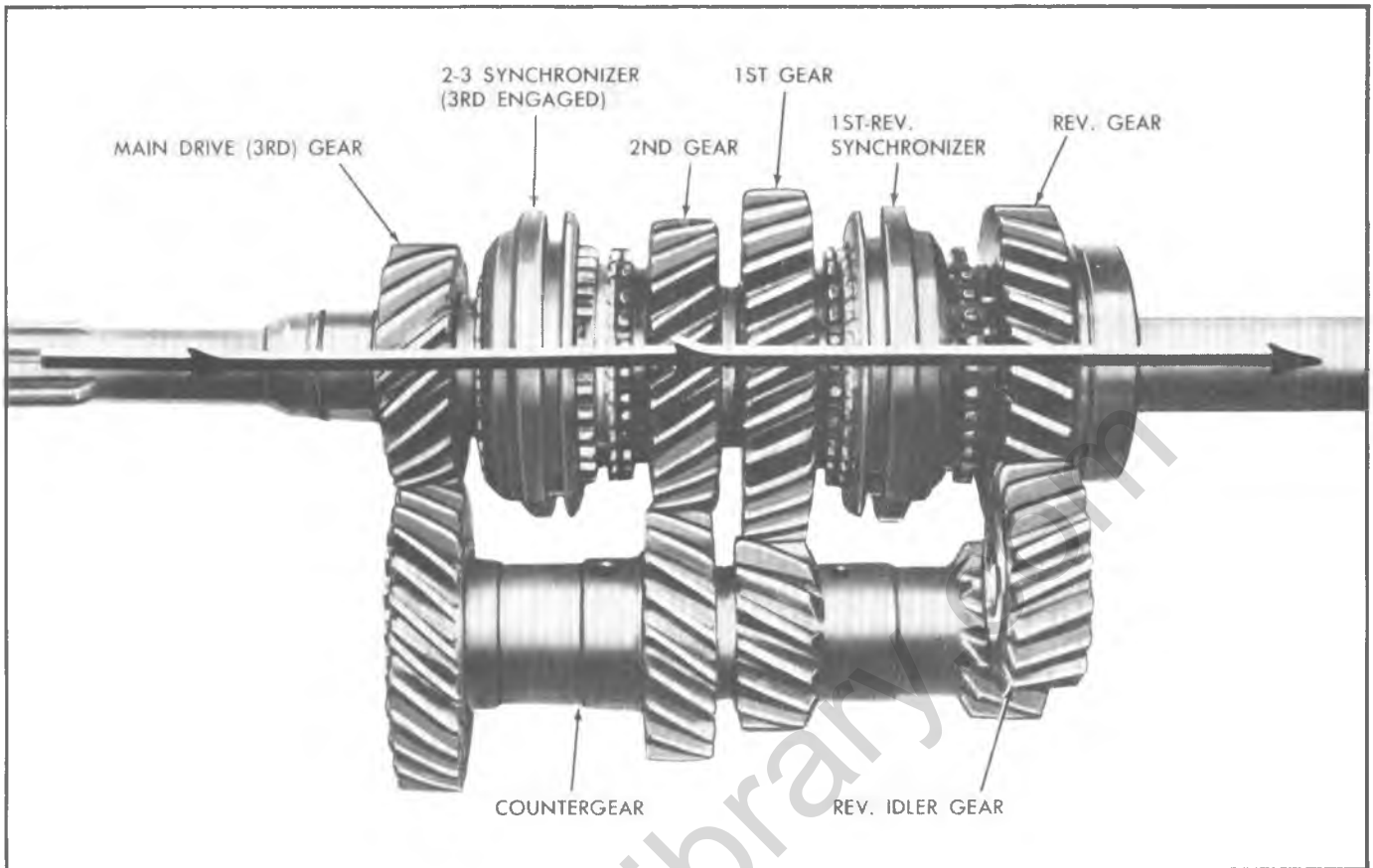

Fig. 21—Third Gear Power Flow

### Third Gear (Fig. 21)

In third speed, or direct drive, the 2nd-3rd sliding sleeve is moved forward to engage the 3rd speed blocking ring and main drive gear and the 1st speed sliding sleeve

remains in a neutral position. This engagement of the main drive gear with the 2nd-3rd sliding sleeve imparts torque directly through the 2nd-3rd synchronizer hub to the mainshaft.

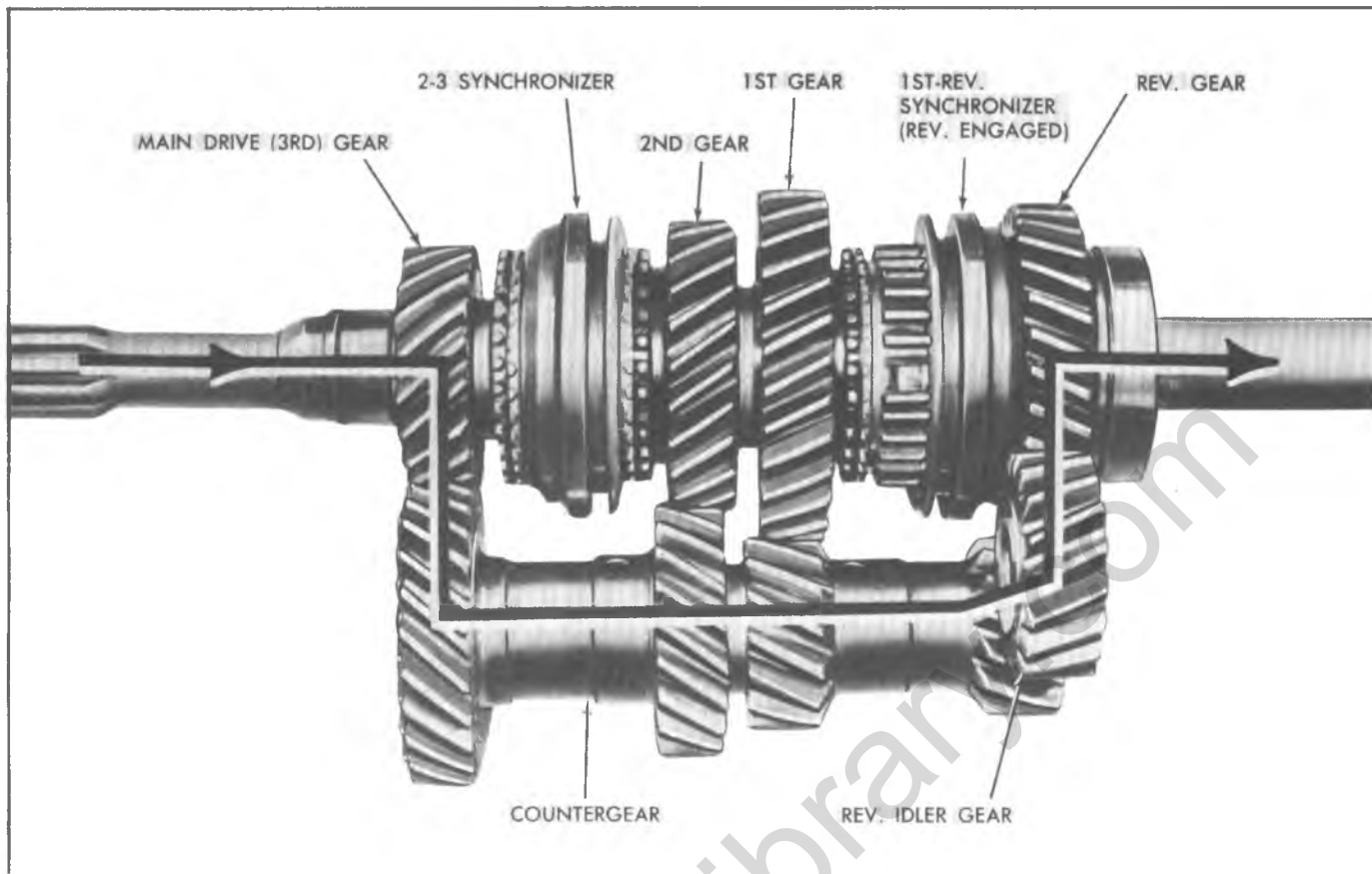

Fig. 22b—Reverse Gear Power Flow

### Reverse Gear (Fig. 22b)

In reverse, the 2nd-3rd sliding sleeve assumes a neutral position. The 1st speed sliding sleeve is moved rearward to engage the reverse gear. Because the reverse gear is held to the mainshaft through the 1st speed synchronizer assembly and reverse gear is in constant mesh with the reverse idler gear, the power flows from the main drive gear to the counter gear and through the reverse idler gear to the reverse gear in a direction of rotation that is opposite that of engine rotation.

It should be noted, that for any forward gear or for reverse gear, only one synchronizer assembly is engaging a gear while the other synchronizer assembly is in a neutral position. And, if both synchronizer assemblies are in the neutral position, no power is being transmitted to the mainshaft. This should be remembered especially when diagnosing manual transmissions for malfunction. For example, if both synchronizer assemblies were engaging gears at the same time the transmission would be locked up and no power would be transmitted through it.

## SERVICE OPERATIONS

### TRANSMISSION LINKAGE ADJUSTMENT

#### 3-Speed Column Shift (Figs. 23, 24 and 25)

In cases where gearshift linkage has been disconnected or removed, proper adjustment sequence is important.

1. Set both shifter levers in neutral position. Install control rods to both second and third shifter lever and first and reverse shifter lever.
2. Align both shifter tube levers on mast jacket in the neutral position. Install gauge (3/16 to 7/32 in.) in holes of levers to hold levers in alignment. Position relay levers so that gearshift control lever is in neutral position.
3. Connect control rods to tube levers making sure clamps are properly adjusted so that tube levers and transmission shifter levers remain in their neutral positions while tightening.

- Remove gauge and move selector lever through all positions to check adjustment and insure over-travel in all positions.

NOTE: If mast jacket lower dash clamp has been disturbed at its mounting on dash, its adjustment to the steering mainshaft should be checked as outlined in Section 9 of this manual.

## TRANSMISSION FLOOR SHIFT CONTROL LEVER REPLACEMENT

- On K-Series models remove transfer case shift lever boot retainer attaching screws and retainer from compartment floor.
- Remove floor covering from vehicle.
- Remove transmission shift lever boot retainer attaching screws.
- Slide boot and retainer up on shift lever and remove the transmission shift lever using Tool J-8109 as shown in Figure 26.
- To install, reverse removal procedure Steps 1-4.

## TRANSFER CASE SHIFT CONTROL LINKAGE ADJUSTMENT

### Model 203 Transfer Case (Fig. 33)

- Position shift control levers in neutral position.
- Disconnect control rods from shift levers at the transfer case.
- Align shift control levers and insert .18 dia. gage pin in lever gauging holes. Both levers should be in the six o'clock position.
- Move transfer case levers to a straight up and down position (six o'clock). Levers should be aligned vertically.
- Loosen control rod swivels and lock nuts. Adjust swivel until it freely enters shift lever and tighten lock nuts. Secure swivel with retainers.
- Remove gage pin from control levers and check operation of assembly. Readjust as required.

## TRANSMISSION REPLACEMENT

### Removal—Except "K" Series Models

- Raise vehicle on suitable hoist and drain lubricant from transmission.
- Disconnect speedometer cable, back-up lamp and TCS switch at transmission.
- Remove shift controls from transmission.

NOTE: On vehicle equipped with Muncie 4-Speed transmission, remove the gearshift lever using Tool J-8109 as shown in Figure

26. Press down firmly and rotate tool counter-clockwise to release gearshift lever.

- Place clean lint-free cloth or other suitable covering over opening on transmission to prevent entry of dirt or foreign material (applies to 4-speed transmissions).
- Disconnect parking brake lever and controls (when used) and back up lamp switch wire.
- If vehicle is equipped with power take-off, remove unit and controls from transmission. Place protective covering over opening.
- Disconnect propeller shaft from transmission as described in "PROPELLER SHAFTS" (SEC.4) of this manual.
- Position a suitable dolly or jack under the vehicle and adjust to carry the weight of the transmission.
- Visually inspect to determine if other equipment, lines or brackets must be removed to permit removal of the transmission. Remove crossmember.

NOTE: Mark front of crossmember to prevent incorrect installation. Tapered surface must be to rear of vehicle.

**CAUTION:** Be sure to support the clutch release bearing and support assembly during removal of the transmission main drive gear from the flywheel housing. This will prevent the release bearing from falling out of the flywheel housing when the transmission is removed.

- Remove flywheel housing underpan and transmission-to-flywheel housing mounting bolts.

**CAUTION:** When removing the transmission, do not allow the weight of the transmission to hang on the clutch disc hub, as the disc will become distorted, seriously affecting clutch operation.

- Move the transmission assembly straight away from the engine, using care to keep the transmission main drive gear shaft in alignment with the clutch disc hub.
- When the transmission is free from the engine, lower the transmission and move from under the vehicle.
- If desired, a careful check of clutch components should be made after the transmission has been removed. If the clutch requires repair, refer to "CLUTCHES" (Section 7) before transmission is reinstalled in the vehicle.

### Installation—Except "K" Series Models

- Apply a light coating of High Temperature Grease to the main drive gear bearing retainer and splined portion of transmission main drive gear shaft to

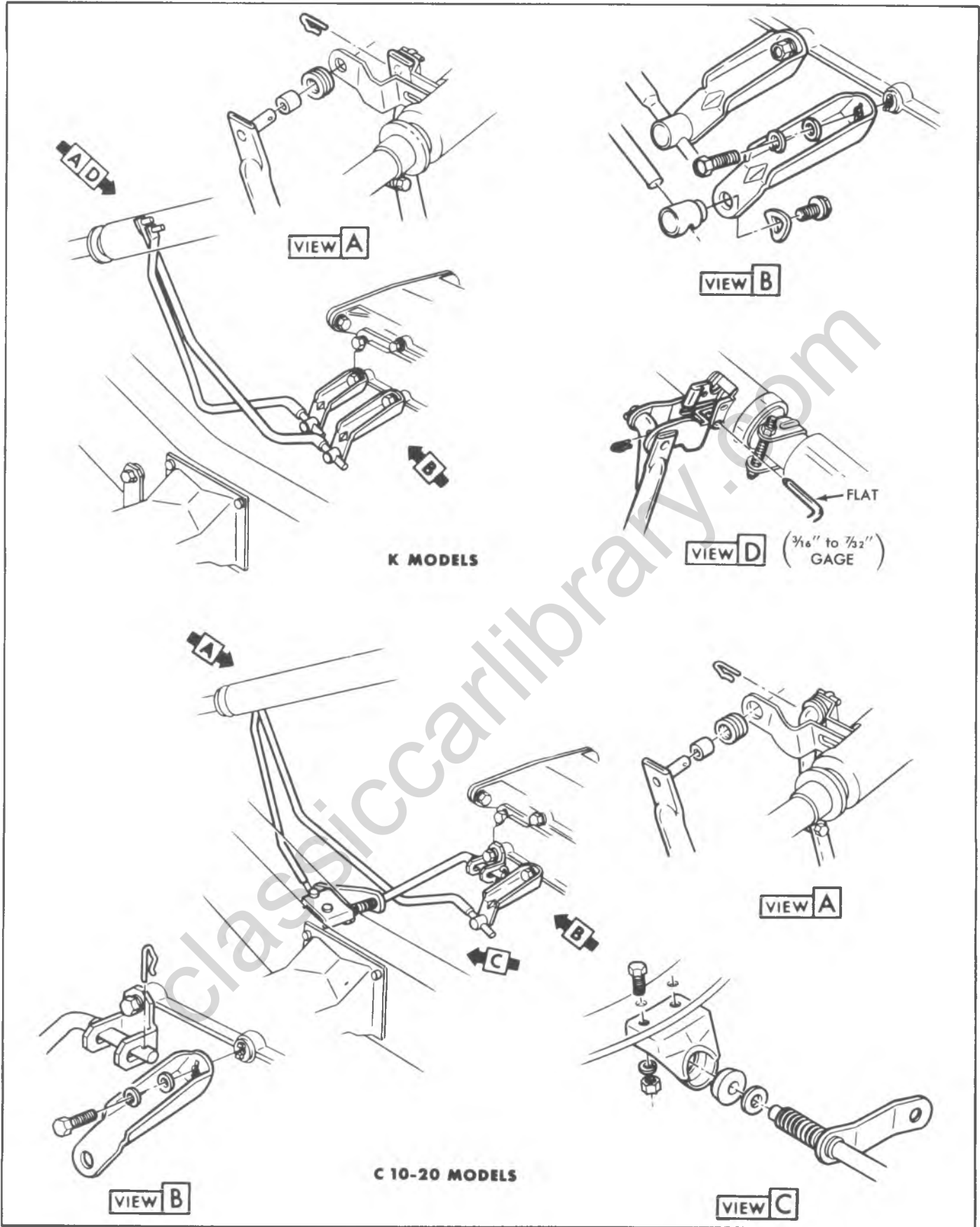

Fig. 23—Column Shift Controls (C-K Models)

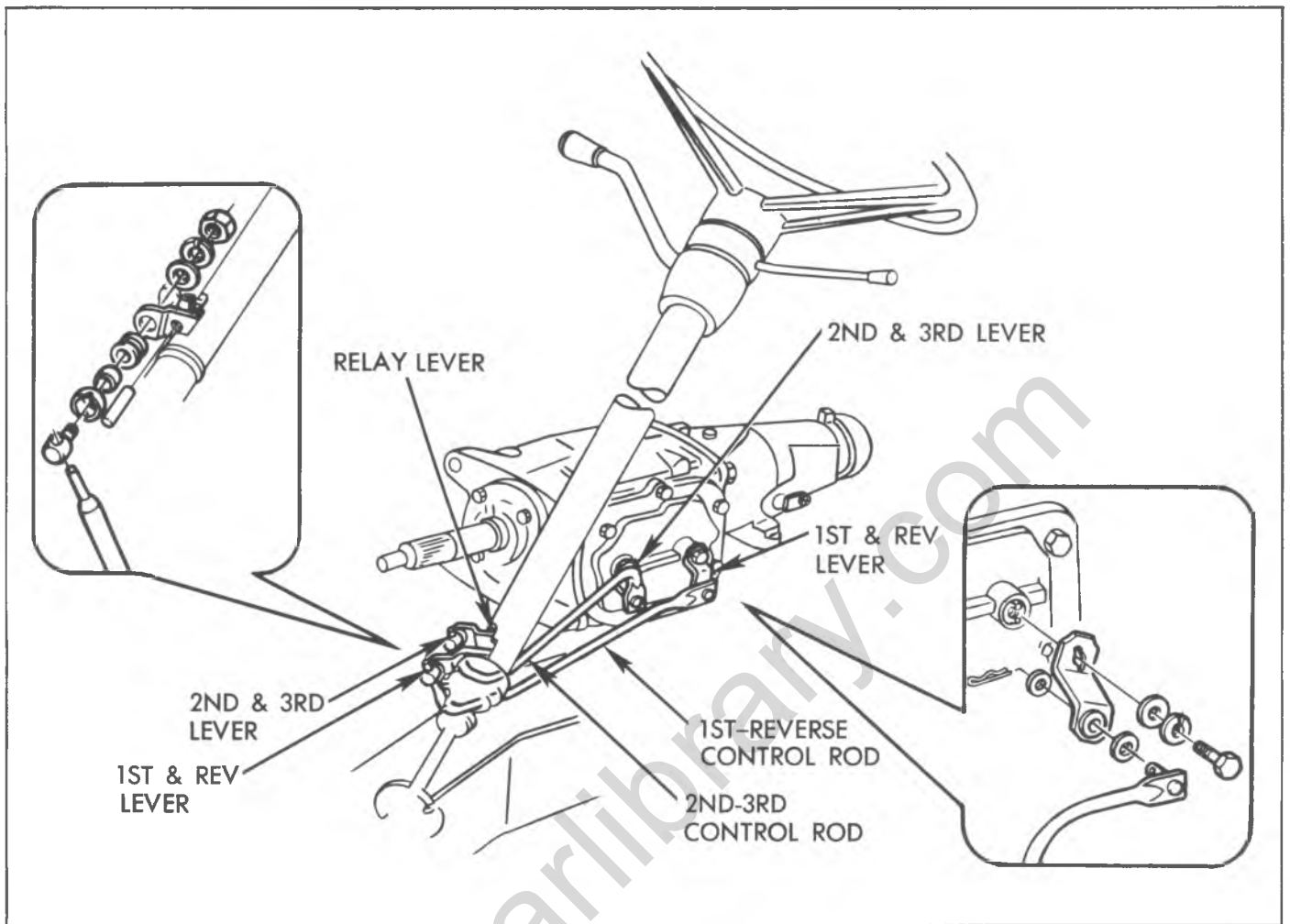

Fig. 24—Column Shift Controls (G Models)

assure free movement of clutch and transmission components during assembly.

**CAUTION:** Do not apply an excessive amount of grease in the above areas, as under normal operation this grease would be thrown onto clutch facings resulting in clutch failure.

2. Shift the transmission into high gear.
3. Mount transmission on dolly or jack and move into position under the vehicle.

**CAUTION:** Avoid springing the clutch when the transmission is being installed to the engine. Do not force the transmission into the clutch disc hub. Do not let the transmission hang unsupported in the splined portion of the clutch disc.

Install flywheel housing-to-transmission mounting bolts and washers. Tighten bolts to specifications.

4. Align the transmission main drive gear shaft with the clutch disc hub by rotating the transmission companion flange or output yoke. Move the

transmission forward, guiding the main drive gear shaft into the clutch disc splines.

5. Install crossmember. Also, if vehicle is equipped with power take-off, reinstall unit and controls on transmission.
6. Connect propeller shaft to transmission as described in "PROPELLER SHAFTS" (Section 4) of this manual. Remove transmission jack.
7. Connect parking brake lever and controls (if used). Adjust brakes as outlined in "PARKING BRAKE" (Section 5) of this manual.
8. Install flywheel housing underpan. Tighten cap screws firmly.
9. Reconnect speedometer cable to adapter at transmission, connect back-up lamp switch wire and TCS switch.
10. Reinstall shift controls on transmission.

**NOTE:** On vehicle equipped with 3-speed transmission, reconnect shift levers to transmission side cover. On vehicle equipped with

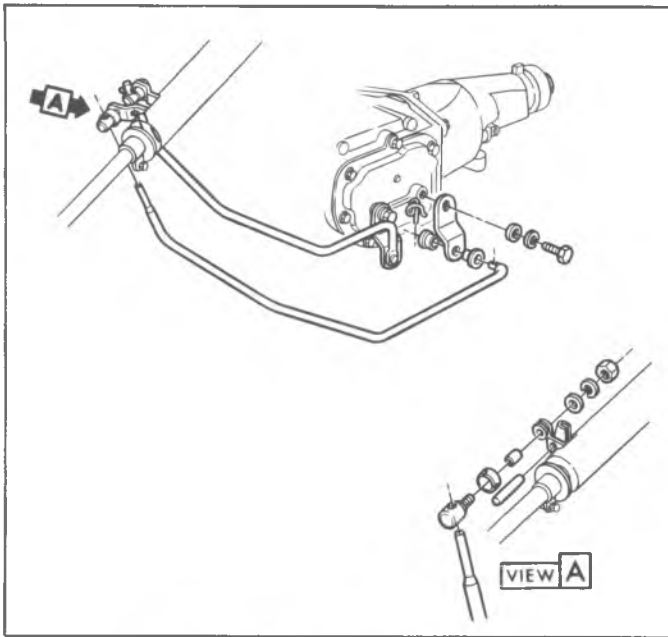

Fig. 25—Column Shift Controls (P Models)

Muncie 4-Speed transmission, install gearshift lever using Tool J-8109 as shown in Figure 11. Press down firmly and rotate clockwise to install gearshift lever. Install transmission floor pan cover and floor mat.

11. If other equipment (exhaust pipe, support brackets, etc.) was removed, reinstall these parts.
12. Refill transmission with lubricant recommended in LUBRICATION (Section 0) of this manual.
13. If necessary, adjust clutch or transmission control linkage to achieve proper transmission operation.

## Replacement—"K" Series

### 3-Speed Transmission

1. Raise vehicle on hoist.
2. Drain transfer case and transmission. Disconnect the speedometer cable from speedometer driven gear fitting, and TCS switch connections.
3. Disconnect propeller shafts front U-joint yoke at case, and tie up out of way.
4. Remove bolt holding the shift lever control assembly to the adapter assembly. Push assembly to one side and tie up out of way.
5. Support transfer case in a suitable cradle. Remove bolts attaching transfer case to adapter.
6. Remove bolts attaching transfer case to frame bracket at right side of case and remove case from adapter.
7. Disconnect shift control rods from the shifter levers at the transmission.
8. Support rear portion of engine. Remove two (2) adapter mount bolts.

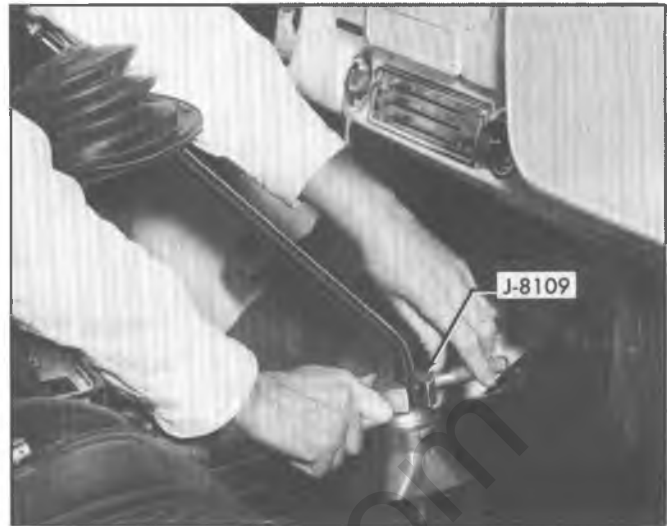

Fig. 26—Removing Transmission Gearshift Lever

9. Remove the 2 top transmission to clutch housing cap screws and insert 2 transmission guide pins, Tool J-1126 in these holes.
10. Remove flywheel under pan. Remove the 2 lower transmission-to-clutch housing cap screws.
11. Slide the transmission and adapter assembly straight back on guide pins until the clutch gear is free of splines in the clutch disc.

NOTE: The use of the 2 guide pins during this operation will support the transmission and prevent damage to the clutch disc through springing.

12. Remove the transmission and adapter as an assembly from under the body.
13. Remove adapter from transmission.
14. To install, reverse removal procedure.

### 4-Speed Transmission—Removal

1. Remove attaching screws from transfer case shift lever boot retainer and remove retainer.
  2. Remove floor mat or carpeting from compartment.
  3. Remove attaching screws from transmission shift lever boot retainer. Slide boot and retainer up lever and remove transmission shift lever using Tool J-8109 as shown in Figure 26.
  4. On Utility models remove center floor outlet from heater distributor duct.
- NOTE: On Utility models equipped with a center console, remove console before proceeding to next step.
5. Remove transmission floor cover attaching screws and cover. Rotate cover approximately 90° to clear transfer case shift lever while lifting cover from vehicle.
  6. Disconnect shift lever link assembly from transfer



- case shift rail connecting rod. Remove shift lever attaching bolt and shift lever control from adapter.
7. Disconnect back-up lamp wiring from switch and remove attaching clamp from top cover bolt.
  8. Raise and support vehicle on hoist. Support engine with suitable floor stand. Drain transfer case and transmission assemblies.
  9. Disconnect speedometer cable from transfer case. Disconnect back-up lamp switch wiring and TCS switch.
  10. Disconnect prop shaft at rear of transfer case and tie up away from work area.
  11. Disconnect front prop shaft from transfer case and tie up away from work area.
  12. Open lock tabs and remove transmission mount-to-frame crossmember bolts. Also remove transfer case-to-frame bracket attaching bolts.
  13. Support transmission and transfer case assembly with suitable floor stand.
  14. Remove frame to crossmember bolts and remove crossmember from vehicle. Rotate crossmember to clear frame rails.
  15. Remove flywheel housing cover. On V-8 engine models, remove exhaust crossover pipe.
  16. Remove transmission to flywheel housing attaching bolts.
 

NOTE: Remove upper bolts first and install transmission guide pins J-1126. Use of the guide pins will prevent damage to the clutch assembly.
  17. Slide transmission rearward until main drive gear clears the clutch assembly and lower assembly from vehicle.

#### 4-Speed Transmission—Installation

1. Position transmission, with transfer case attached to the flywheel housing. Install bolts attaching transmission to flywheel housing.
2. Install flywheel housing cover and attaching bolts. On V-8 models, install exhaust crossover pipe.
3. Position frame crossmember and install retaining bolts. Install bolts retaining adapter assembly to crossmember and transfer case to frame rail bracket. Torque all bolts to specification.
4. Torque front and rear transfer case yoke lock nuts to specifications.
5. Install front and rear propshafts to transfer case output yokes.
6. Connect the speedometer cable, back-up lamp wiring and TCS switches.
7. Fill transmission and transfer case to proper level with lubricant specified in the lubricant section, Truck Chassis Service Manual.

8. Install transfer case shift lever assembly and attaching bolt. Connect shift lever link to shift rail bar.
9. Install transmission floor cover and attaching bolts.
10. Install heater distributor duct center outlet.
 

NOTE: On models with center console, install console and retaining bolts.
11. Install floor mat, transfer case shift lever retainer and attaching screws.
12. Install transmission shift lever.

#### TRANSMISSION ALIGNMENT

In some instances where "excessive" gear whine or high gear hop out, particularly at 50 MPH and up, are encountered; and after all other probable causes have been checked, an alignment check of the transmission and clutch housing may be helpful.

A special tool, on which a dial indicator is mounted, is necessary to check the transmission case rear bore alignment. This tool may be made from a new or good used clutch gear which has a good bearing surface on the crankshaft pilot end and at the front main bearing location.

The splines on the clutch gear shaft and the teeth on the clutch gear should be ground off so the shaft may be rotated in a clutch disc hub without interference when assembled in the car. Weld a piece of 1/4" rod in the mainshaft pilot bore long enough to extend out the case rear bore. Assemble a good bearing on the clutch gear shaft and secure it with the clutch gear bearing snap ring. Attach a suitable dial indicator to the rod.

#### Procedure

1. Remove the transmission from the vehicle and completely disassemble, except for the reverse idler gear.

NOTE: In any case where the clutch gear pilot or pilot bearing is excessively loose or worn, the pilot bearing should be replaced before checking the transmission case rear bore alignment by the dial indicator method.

2. Carefully install the special tool with the dial



Fig. 27—Removing Mainshaft Rear Oil Seal

## 7M-34 CLUTCHES & MANUAL TRANSMISSIONS

indicator in the transmission case with the face of the indicator to the rear of the case and with the tracing finger contacting the I.D. of the case rear bore. Secure in place with a clutch gear bearing retainer.

3. Assemble the transmission case to the clutch housing and tighten the four transmission mounting bolts securely.

**NOTE:** Be sure to clean off any paint or other foreign material on the mating faces of the clutch housing and transmission as any foreign material on these faces will change alignment; also, check carefully for dings or burrs on these mating surfaces and remove carefully as necessary.

4. Dial indicate the transmission case rear bore and record the indicator readings in the 12, 3, 6 and 9 o'clock positions.

**NOTE:** It is best to start the reading at the 3, 6, 9 or 12 o'clock position closest to the point where the indicator plunger reaches its maximum outward travel. Set the dial indicator at "O" at this location and then record the 3, 6, 9 and 12 o'clock readings in rotation.

5. Install temporary slotted shims between the transmission case and the clutch housing in the quantities and at the bolt locations as necessary to bring misalignment at the transmission case rear bore to a maximum of .005" indicator reading in either the vertical or horizontal direction.

**EXAMPLE:** If the maximum indicator reading is at the 12 o'clock position, put shims on the two bottom bolts.

6. After the position and quantity of shims has been determined and recorded the transmission case may be removed.

**NOTE:** The clutch housing should then be stamped, showing the position where shims are to be installed and the thickness of shims at each location.

7. Inspect the external clutching teeth of the clutch gear and second speed gear. Inspect the second and third speed clutch internal clutching teeth. If the teeth are worn or tapered, even slightly, the gears should be replaced. Reassemble the transmission.
8. Install the transmission assembly to the clutch housing, using the correct number of shims at the proper locations as previously determined. Shims are available by unit part number with each unit consisting of the following shims:

4--.002" shims Identification--two corners cut off.

2--.005" shims Identification--one corner cut off.

1--.010" shims Identification--all corners square.

**NOTE:** These special shims have a tab on one end for ease of installation. Do not slot the shims for the permanent installation.

### REAR OIL SEAL REPLACEMENT

1. Drain lubricant from transmission.
2. Disconnect propeller shaft from transmission as described in "PROPELLER SHAFTS" (Section 4) of this manual.
3. On 3-speed transmissions, perform the following replacement procedures:
  - a. Remove slip joint yoke from rear of transmission mainshaft.
  - b. Pry seal out of extension housing or remove oil seal using oil seal remover (J-5859) and slide hammer (J-2619) as shown in Figure 27.
  - c. Coat outer diameter of new oil seal with sealing cement. Install new oil seal using extension housing oil seal installer (J-5154).
  - d. Install slip joint yoke on rear of transmission mainshaft.
4. On Muncie 4-speed transmissions, perform the following:
  - a. Remove parking brake from rear of transmission as described in "PARKING BRAKE" (Section 5), when used.
  - b. Disconnect speedometer cable and remove speedometer driven gear from mainshaft rear bearing cap.
  - c. Using flange or yoke holding tool, remove the output yoke or companion flange nut. Pull output yoke or companion flange nut off the mainshaft.
  - d. Remove mainshaft rear bearing cap and gasket. Discard gasket.
  - e. Remove oil seal from rear bearing cap. Discard oil seal.
  - f. Coat outer diameter of new oil seal with sealing cement. Install oil seal in rear bearing cup using a suitable installer. Drive seal flush with outside of rear bearing cap, being careful not to damage seal as shown in Figure 13.

**NOTE:** On Muncie 4-speed use Installer J-22834 with Adapter J-22834-1 as required.

- g. Clean all gasket surfaces, then install the rear bearing cap with a new gasket on the transmission. Tighten cap screws firmly.
- h. Install output yoke or companion flange or mainshaft. Using a flange or yoke holding tool install retaining nut. Torque the retaining nut to specification.

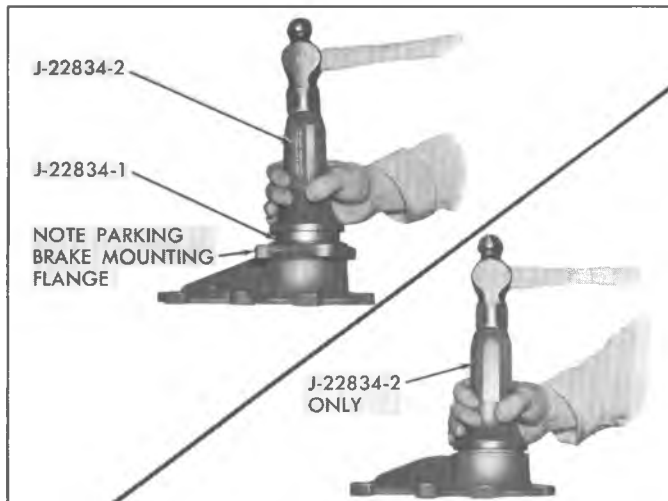

Fig. 28—Replacing Rear Bearing Retainer Oil Seal

- i. Install speedometer driven gear, then connect speedometer cable.
5. Reconnect propeller shaft to transmission as described in "PROPELLER SHAFTS" (Section 4) of this manual.
6. Refill transmission with lubricant recommended in LUBRICATION (Section 0) of this manual.

### SPEEDOMETER DRIVEN GEAR REPLACEMENT

Disconnect speedometer cable, remove lock plate to housing bolt and lock washer and remove lock plate. Insert screw driver in lock plate slot in fitting and pry fitting, gear and shaft from housing. Pry "O" ring from groove in fitting.

Install new "O" ring in groove in fitting, coat "O" ring and driven gear shaft with transmission lubricant and insert shaft.

Hold the assembly so slot in fitting is toward lock plate boss on housing and install in housing. Push fitting into housing until lock plate can be inserted in groove and attached to housing.

### TRANSMISSION SIDE COVER REPLACEMENT/REPAIR

#### Saginaw and Muncie 3-Speed (Fig. 29)

1. Disconnect control rods from levers, back-up lamp wiring and TCS switch.
2. Shift transmission into neutral detent positions before removing cover. Remove cover assembly from transmission case carefully and allow oil to drain.

3. Remove the outer shifter levers.
4. Remove both shift forks from shifter shaft assemblies. Remove both shifter shaft assemblies from cover. Seals around shifter shaft may now be pried out if replacement is required because of damage.
5. Remove detent cam spring and pivot retainer "C" ring. Remove both detent cams.
6. With detent spring tang projecting up over the 2nd and 3rd shifter shaft cover opening install the first and reverse detent cam onto the detent cam pivot pin. With the detent spring tang projecting up over the first and reverse shifter shaft cover hole install the 2nd and 3rd detent cam.
7. Install detent cam retaining "C" ring to pivot shaft, and hook spring into detent cam notches.
8. Install both shifter shaft assemblies in cover being careful not to damage seals. Install both shift forks to shifter shaft assemblies, lifting up on detent cam to allow forks to fully seat into position.
9. Install outer shifter levers, flat washers, lock washers and bolts.
10. Shift shifter levers into neutral detent (center) position and slide cover into place making sure the shift forks are aligned with their respective mainshaft clutch sliding sleeves.
11. Install cover attaching bolts and tighten evenly to specified torque. Install TCS switch and connect wiring.
12. Remove filler plug and add lubricant specified in Section 0, to level of filler plug hole.

### TRANSFER CASE REPLACEMENT (Figs. 30 thru 34)

#### Removal

1. Raise and support vehicle on hoist. Drain transfer case.
2. Disconnect speedometer cable, back-up lamp and TCS switch.
3. Remove skid plate and crossmember supports as necessary.
4. Disconnect rear prop shaft from transfer case and tie up away from work area.
5. Disconnect front prop shaft from transfer case and tie up shaft away from work area.
6. Disconnect shift lever rod from shift rail link. On full time 4 wheel drive models, disconnect shift levers at transfer case.
7. Remove transfer case to frame mounting bracket bolts.

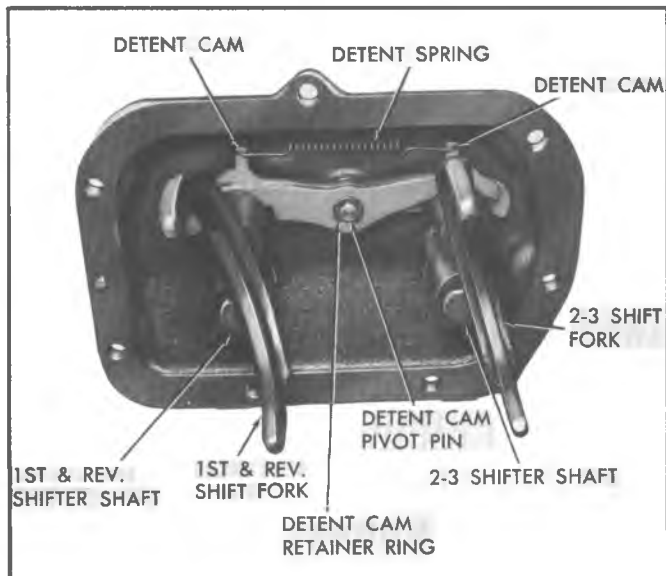

Fig. 29—Transmission Side Cover Assy. (3-Speed Saginaw)

## Installation

1. Support transfer case in suitable stand and position case to transmission adapter. Install bolts attaching case to adapter and torque to 45 ft. lbs.
2. Remove stand as required and install bolts attaching transfer case to frame rail. Bend lock tabs after assembly.
3. Install connecting rod to shift rail link or connect shift levers to transfer case, as applicable.
4. Connect front prop shaft to transfer case front output shaft.
5. Connect rear prop shaft to transfer case rear output shaft.
6. Install crossmember support and skid plate, if removed.
7. Connect speedometer cable, back-up lamp and TCS switch.
8. Fill transfer case to proper level with lubricant specified in the lubricant section of the Truck Chassis Service Manual.
9. Lower and remove vehicle from hoist.

**CAUTION:** Check and tighten all bolts to specified torques.

**NOTE:** Before connecting prop shafts to companion flanges be sure locknuts are torqued to specifications.

8. Support transfer case and remove bolts attaching transfer case to transmission adapter.
9. Move transfer case to rear until input shaft clears adapter and lower assembly from vehicle.

classiccarslibrary.com

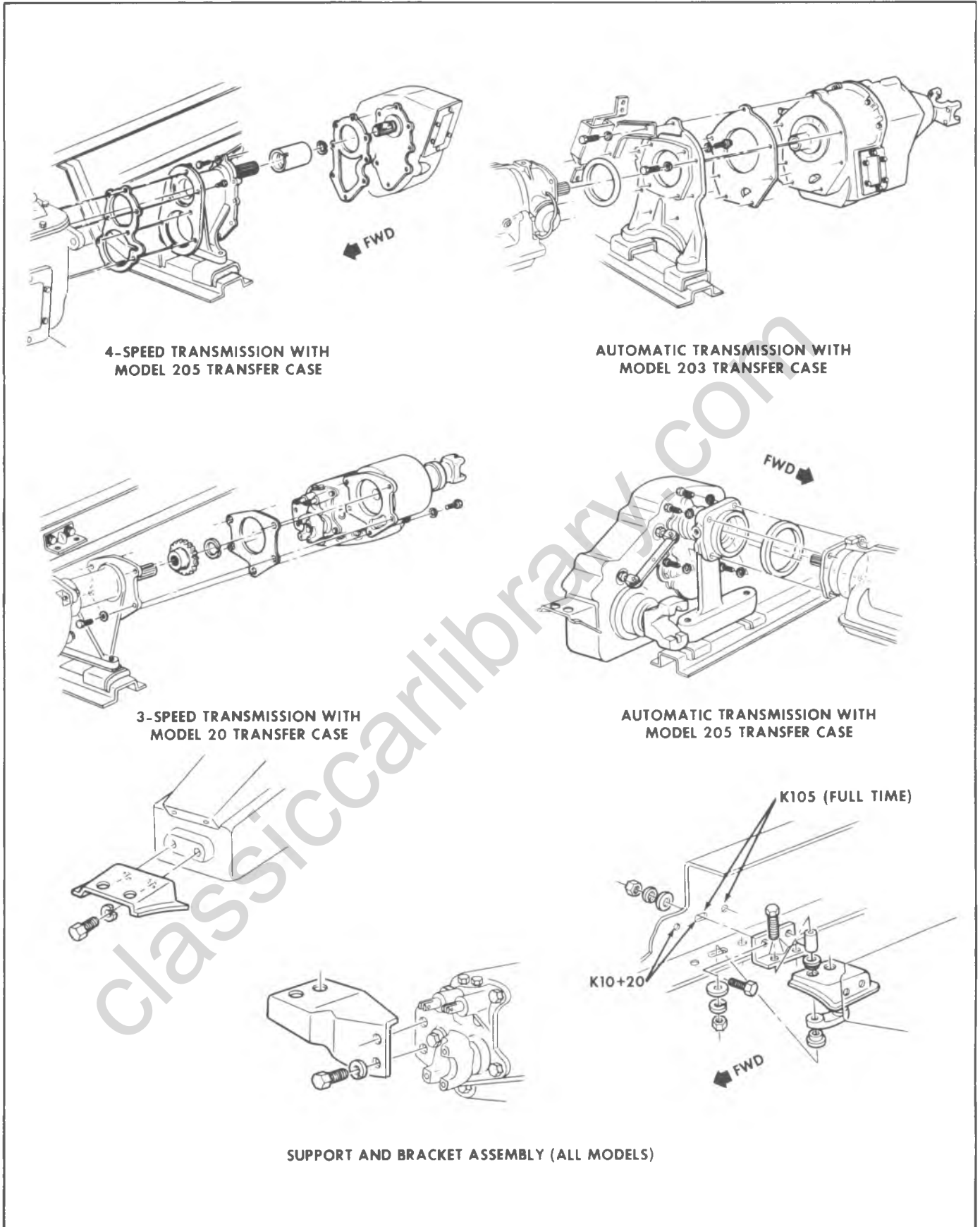

Fig. 30—Transfer Case Installation

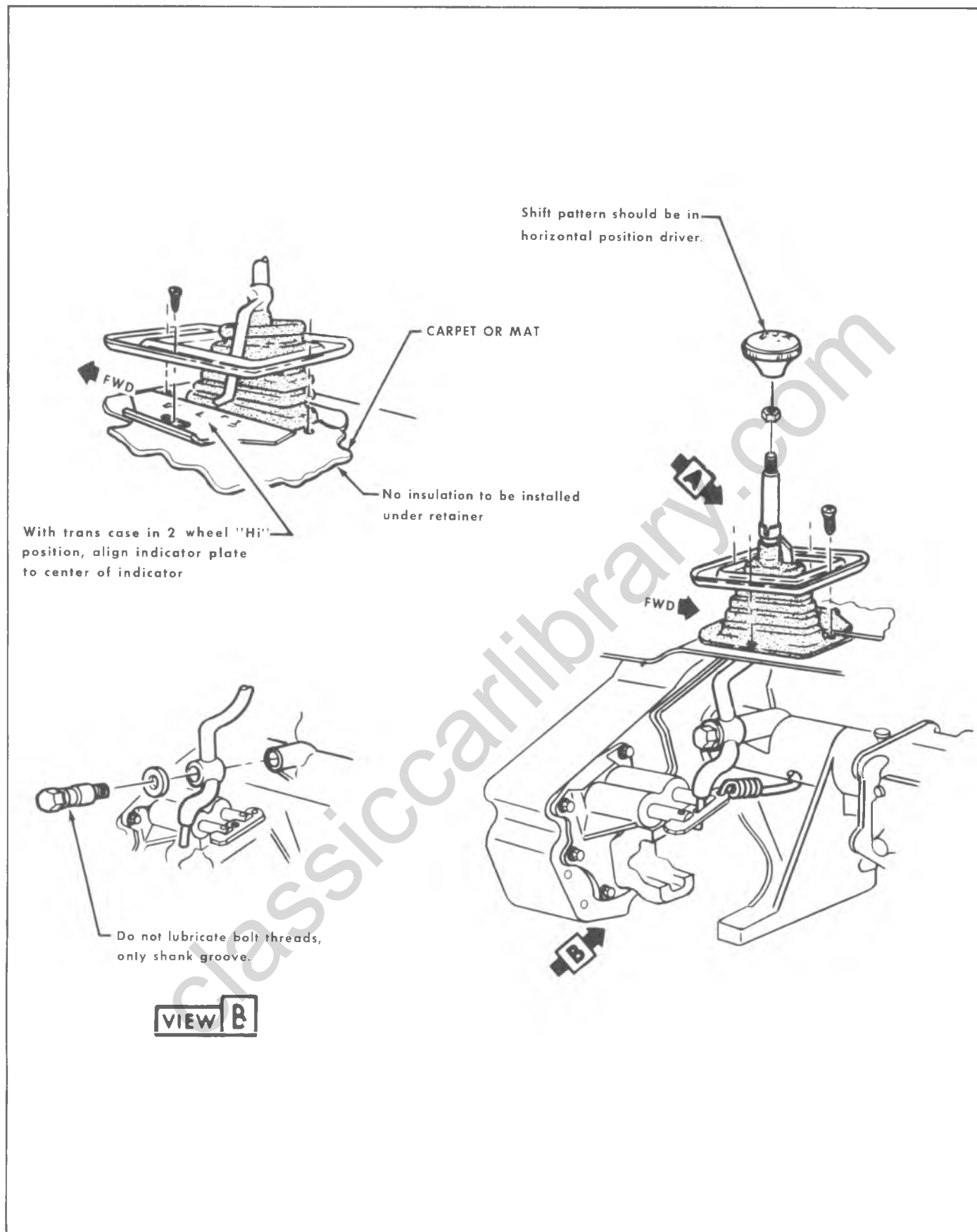

Fig. 31—Model 20 Transfer Case Controls

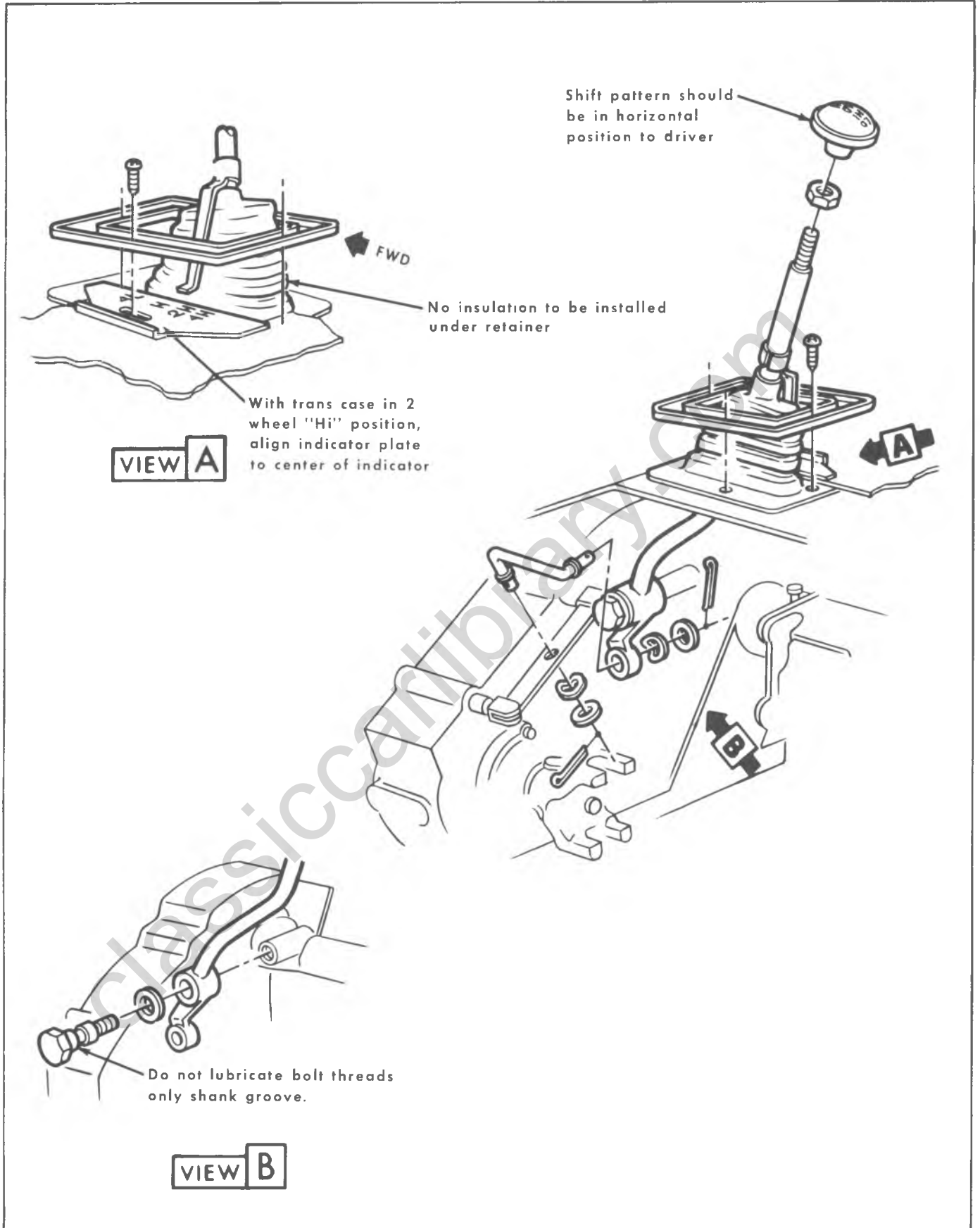

Fig. 32—Model 205 Transfer Case Controls

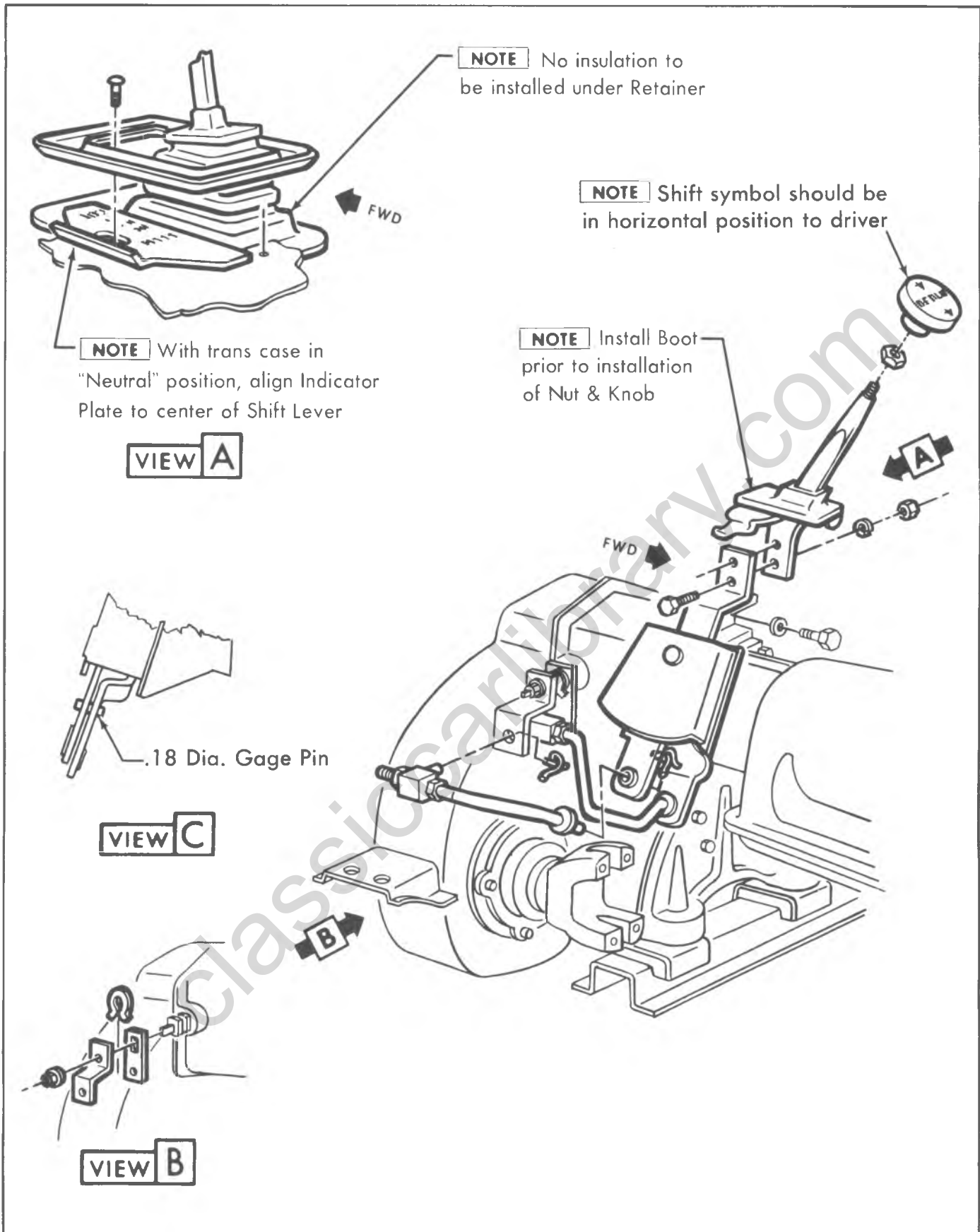

Fig. 33—Model 203 Transfer Case Controls



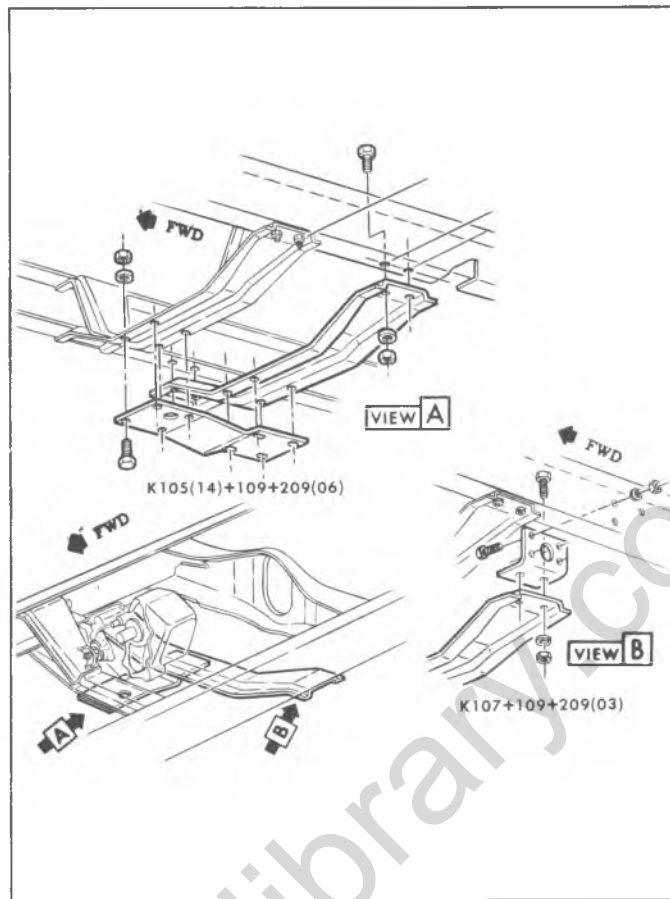

Fig. 34—Transfer Case Skid Plate (K105)

## DIAGNOSIS

Before attempting to repair the clutch, transmission or related linkages for any reason other than an obvious failure, the problem and probable cause should be identified. A large percentage of clutch and manual transmission problems are manifested by shifting difficulties such as high shift effort, gear clash and grinding or transmission blockout. When any of these problems occur a careful analysis of these difficulties should be accomplished, and the following checks and adjustments performed in the presented sequence before removing the clutch or transmission for repairs.

### CLUTCH ADJUSTMENT

#### A. Clutch Free Pedal Travel

1. The clutch free pedal travel adjustment should be made as outlined in the Clutch and Transmission section of the Chassis Service Manual for the specific vehicle involved.
2. Check clutch linkage for lost motion caused by loose or worn swivels, deflection of mounting brackets or damaged cordon shaft.

#### B. Clutch Spin Down Time

1. Run the engine at a normal idle with transmission in neutral and clutch engaged.
2. Disengage the clutch, wait nine seconds and shift the transmission to reverse. No grinding noise should be heard. A grinding noise indicates incorrect clutch adjustment, lost motion clutch misalignment, or internal problems such as failed dampers, facings, cushion springs, diaphragm spring fingers, pressure plate drive straps, etc.

### SHIFT LINKAGE ADJUSTMENT

#### A. Steering Column Shift Control

1. Remove the shift control rods from the column levers.
2. Check shift effort at the shift control lever knob. (Effort should not exceed 2 lbs. with transmission linkage removed.)
3. If binding is felt, refer to the adjustment procedure for the steering column lower bearing for Manual

Shift Torque Chart

Shift Torque In. Lbs.	3-Saginaw	3-Muncie
	50	60

Transmission Column Shift as described in the Steering Section of the appropriate Chassis Service Manual.

- Lubricate all rod and swivel connections and re-check shift effort after installation.
- If shift linkage is free from binding, the column levers should be checked for end play. A .005 feeler gauge should fit between the levers and control lever.
- Connect control rods and check steering column control levers for alignment. In neutral, the column control lever tangs should line up with the slot in the main control lever.

## B. Floor Shift Control

All swivels, rods and mountings should be checked for lost motion and repaired or replaced as necessary. Transmission control levers should be checked for wear and repaired or replaced as necessary.

## TRANSMISSION SHIFT EFFORT

### A. Transmission Shift Effort Checking Procedures

- Remove the shift rods at the transmission and align the sleeve, blocker ring and gear by shifting into the offending gear and then back into neutral.
- Check the torque required to shift into gear with an inch pound torque wrench on the shift lever attaching bolt. If more than the specified torque (see below) is required, the transmission shift lever should be checked for rust or dirt binding the lever.
- Clean levers, lubricate and recheck the torque value.

NOTE: If at this point in the procedure, it is found that high shift effort or gear clashing still exists, an anti-chatter lubricant (positraction additive) should be used. The lubricant is available in a 4 oz. plastic bottle and can be squirted into the transmission through the filler plug.

### B. Transmission Internal Problems Related to Shift Effort

When the above procedures have been checked and the problem still exists, the transmission will have to be removed and disassembled for further diagnosis. There are three basic types of transmission internal problems reflected by shifting effort.

- Hard Shifting** — The effort to shift is excessive, but the gears engage. The lever moves with excessive

effort throughout the entire travel range. If the static shift effort is high, (clutch depressed, engine not running) the synchronizer sleeve and hubs should be checked for a tight fit. With the three synchronizer keys removed, the sleeve should be loose on the hub. If the hub and sleeve are not a loose fit, replace the synchronizer assembly.

- Blockout** — The lever moves freely until the synchronizer is engaged. Synchronization should be heard to take place, but the gear will not engage. When it does engage, a double bump is generally felt in the lever. The synchronized blocker ring can be damaged by excessive force on gear cones that are finished improperly. The blocker ring material may stick to the synchronizer gear cone causing it to be a yellowish brass color, in streaks, which results in hard shifts when present. The gear cone should be a bright silver color. Polish the gear cone with 400 grit paper to a bright silver when this condition is present. The blocker rings should be replaced if the thread is damaged or worn.
- Clash** — Gear clash is a typical sound which occurs when the sleeve and gear chamfers contact each other in the unsynchronized state. The characteristics of clash are a grating or loud buzzing sound from the transmission. The shift lever load will be lower, but a vibration should be felt. The Noise (clash) can be for a short instant or long enough to keep the gear from being engaged. This condition should not be confused with hard shifting or reported as such. Hard shifting and clash are directly opposite conditions. When the clash is slight, the load will build up on the shift lever and then fall off rapidly followed by the grating sound.

If the transmission has been clashing, the sleeve ends should be examined for chipping and burrs. If the sleeves are damaged, the synchronizer assemblies and blocker rings should be replaced. Synchronizer sleeve ends should have an angular surface. The surfaces should be even from side to side and the radii indicated should be very small. Any chipping will require synchronizer replacement.

Check the synchronizer load. When the keys are installed, the spring ends on one side of the hub should be hooked in one key and the spring on the opposite side of the synchronizer should not be hooked on the same key. A definite load should be felt when the sleeve is moved on the hubs with the keys and springs in proper position.

## SHIFTING DIFFICULTY DIAGNOSIS CHART

CONDITION	PROBABLE CAUSE	CORRECTION
High Shift Effort-Column Shift (Effort exceeds 2 ft. lbs. at lever knob with transmission linkage disconnected.)	Binding of column levers	Adjust column mechanism per Section 9, Steering of the Chassis Service Manual
	Lever end play exceeds .005 in.	Clean and lubricate all rod and swivel connections.
	Misalignment of column control levers.	Adjust levers
High Shift Effort-Floor Shift (crossover from 1st-2nd to 3rd-4th position cannot be accomplished without offset or step)	Improper linkage Adjustment	Adjust linkage
	Lost motion due to damaged or worn swivels, rods, grommets or mountings.	Repair or replace defective components.
	Loose lever attaching bolts	Tighten bolts and check levers for correct fit on shifter shafts.
	Binding	Clean and Adjust linkage
	Stiff shift lever boot	Replace boot
Gear Clash and binding	Improper linkage Adjustment	Adjust Shift linkage
Lost motion	Loose or worn swivels and grommets. Deflection of Mounting Brackets. Loose shift levers. Damaged Cordon Shaft	Replace defective parts

## MANUAL TRANSMISSION DIAGNOSIS CHART

CONDITION	PROBABLE CAUSE	CORRECTION
Slips out of High Gear	<ul style="list-style-type: none"> <li>a. Transmission loose on clutch housing</li> <li>b. Shift rods interfere with engine mounts or clutch throw-out lever</li> <li>c. Shift linkage does not work freely; binds</li> <li>d. Damaged mainshaft pilot bearing</li> <li>e. Main drive gear retainer broken or loose</li> <li>f. Dirt between transmission case and clutch housing</li> <li>g. Misalignment of transmission</li> <li>h. Stiff shift lever seal</li> <li>i. Pilot bearing loose in crankshaft</li> <li>j. Worn or improperly adjusted linkage</li> </ul>	<ul style="list-style-type: none"> <li>a. Tighten mounting bolts</li> <li>b. Replace or bend levers and rods to eliminate interference</li> <li>c. Adjust and free up shift linkage</li> <li>d. Replace pilot bearing</li> <li>e. Tighten or replace main drive gear</li> <li>f. Clean mating surfaces</li> <li>g. Refer to TRANSMISSION ALIGNMENT</li> <li>h. Replace seal</li> <li>i. See Section 6 for brg. fits</li> <li>j. Adjust or replace linkage as required</li> </ul>
Noisy in All Gears	<ul style="list-style-type: none"> <li>a. Insufficient lubricant</li> <li>b. Worn countergear bearings</li> <li>c. Worn or damaged main drive gear and countergear</li> <li>d. Damaged main drive gear or main shaft bearings</li> <li>e. Worn or damaged countergear anti-lash plate</li> </ul>	<ul style="list-style-type: none"> <li>a. Fill to correct level</li> <li>b. Replace countergear bearings and shaft</li> <li>c. Replace worn or damaged gears</li> <li>d. Replace damaged bearings or main drive gear</li> <li>e. Replace countergear</li> </ul>
Noisy in High Gear	<ul style="list-style-type: none"> <li>a. Damaged main drive gear bearing</li> <li>b. Damaged mainshaft bearing</li> <li>c. Damaged high speed gear synchronizer</li> </ul>	<ul style="list-style-type: none"> <li>a. Replace damaged bearing</li> <li>b. Replace damaged bearing</li> <li>c. Replace synchronizer</li> </ul>
Noisy in Neutral with Engine Running	<ul style="list-style-type: none"> <li>a. Damaged main drive gear bearing</li> <li>b. Damaged or loose mainshaft pilot bearing</li> <li>c. Worn or damaged countergear anti-lash plate</li> <li>d. Worn countergear bearings</li> </ul>	<ul style="list-style-type: none"> <li>a. Replace damaged bearing</li> <li>b. Replace pilot bearings. See Section 6 for bearing fits</li> <li>c. Replace countergear</li> <li>d. Replace countergear bearings and shaft</li> </ul>
Noisy in all Reduction Gears	<ul style="list-style-type: none"> <li>a. Insufficient lubricant</li> <li>b. Worn or damaged main drive gear or countergear</li> </ul>	<ul style="list-style-type: none"> <li>a. Fill to correct level</li> <li>b. Replace faulty or damaged gears</li> </ul>
Noisy in Second Only	<ul style="list-style-type: none"> <li>a. Damaged or worn second-speed constant mesh gears</li> <li>b. Worn or damaged countergear rear bearings</li> <li>c. Damaged or worn second-speed synchronizer</li> </ul>	<ul style="list-style-type: none"> <li>a. Replace damaged gears</li> <li>b. Replace countergear bearings and shaft</li> <li>c. Replace synchronizer</li> </ul>
Noisy in Third Only (Four Speed)	<ul style="list-style-type: none"> <li>a. Damaged or worn third-speed constant mesh gears</li> <li>b. Worn or damaged countergear bearings</li> </ul>	<ul style="list-style-type: none"> <li>a. Replace damaged gears</li> <li>b. Replace damaged countergear bearings and shaft</li> </ul>

## MANUAL TRANSMISSION DIAGNOSIS CHART (CONT'D.)

CONDITION	PROBABLE CAUSE	CORRECTION
Noisy in Reverse Only	<ul style="list-style-type: none"> <li>a. Worn or damaged reverse idler gear or idler bushing</li> <li>b. Worn or damaged reverse gear on mainshaft</li> <li>c. Damaged or worn reverse countergear</li> <li>d. Damaged Shift mechanism</li> </ul>	<ul style="list-style-type: none"> <li>a. Replace reverse idler gear assembly</li> <li>b. Replace reverse gear</li> <li>c. Replace countergear assembly</li> <li>d. Inspect linkage and adjust or replace damaged parts</li> </ul>
Excessive Backlash in all Reduction Gears	<ul style="list-style-type: none"> <li>a. Worn countergear bearings</li> <li>b. Excessive end play in countergear</li> </ul>	<ul style="list-style-type: none"> <li>a. Replace bearings</li> <li>b. Replace countergear thrust washers</li> </ul>
Main Drive Gear Bearing Retainer Burned or Scored by Input Shaft	<ul style="list-style-type: none"> <li>a. Loose or damaged mainshaft pilot bearing</li> <li>b. Misalignment of transmission</li> </ul>	<ul style="list-style-type: none"> <li>a. Replace bearing. See Section 6 for bearing fit</li> <li>b. Align transmission</li> </ul>
Leaks Lubricant	<ul style="list-style-type: none"> <li>a. Excessive amount of lubricant in transmission</li> <li>b. Loose or broken main drive gear bearing retainer</li> <li>c. Main drive gear bearing retainer gasket damaged</li> <li>d. Side cover loose or gasket damaged</li> <li>e. Rear bearing retainer oil seal leaks</li> <li>f. Countershaft loose in case</li> <li>g. Shift lever seals leak</li> </ul>	<ul style="list-style-type: none"> <li>a. Drain to correct level</li> <li>b. Tighten or replace retainer</li> <li>c. Replace gasket</li> <li>d. Tighten cover or replace gasket</li> <li>e. Replace seal</li> <li>f. Replace case</li> <li>g. Replace seal</li> </ul>

## SPECIAL TOOLS



1. J-6456 Height Gauge
2. J-1048 Gauge Plate
3. J-1522 Pilot Bearing Driver
4. J-23720 Clutch Pilot Tool
5. J-1448 Pilot Bearing Puller

Fig. 1ST—Clutch Special Tools

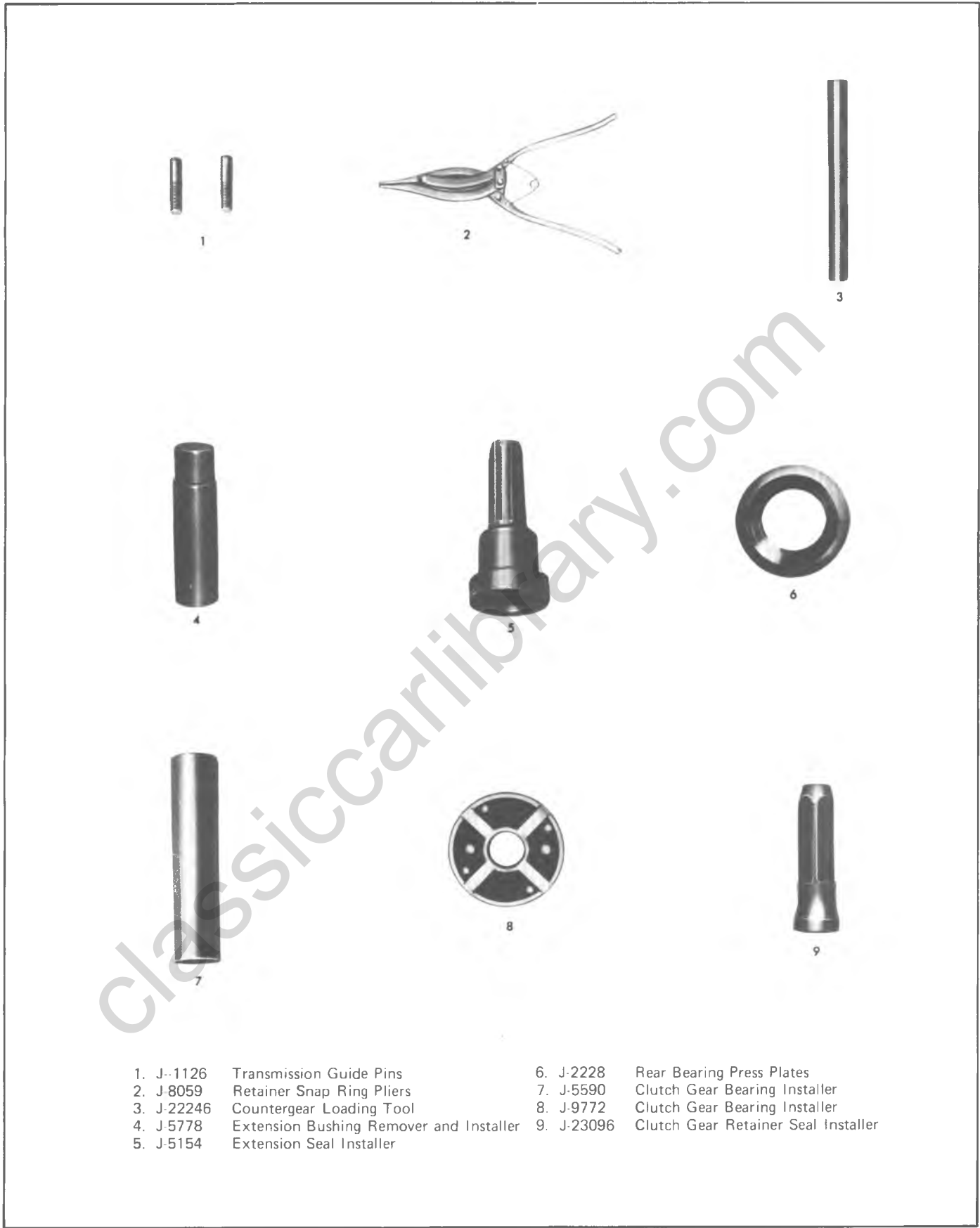

- |            |   |            |                                     |
|------------|---|------------|-------------------------------------|
| 1. J-1126  | Transmission Guide Pins                 | 6. J-2228  | Rear Bearing Press Plates           |
| 2. J-8059  | Retainer Snap Ring Pliers               | 7. J-5590  | Clutch Gear Bearing Installer       |
| 3. J-22246 | Countergear Loading Tool                | 8. J-9772  | Clutch Gear Bearing Installer       |
| 4. J-5778  | Extension Bushing Remover and Installer | 9. J-23096 | Clutch Gear Retainer Seal Installer |
| 5. J-5154  | Extension Seal Installer                |            |                                     |

Fig. 2ST-3-Speed Manual Transmission Special Tools



- |             |   |                |   |
|-------------|---|----------------|---|
| 1. J-22832  | Countergear Rear Bearing Remover          | 8. J-22874-1   | Bearing Installer                         |
| 2. J-8433-1 | Bearing Puller                            | 9. J-22874-5   | Mainshaft Support Tool                    |
| 3. J-22872  | Clutch Gear Bearing Remover and Installer | 10. J-22874-2  | Countershaft Support Tool                 |
| 4. J-22833  | Front Bearing Retainer Seal Installer     | 11. J-22834-2  | Rear Bearing Retainer Seal Installer      |
| 5. J-22873  | 2nd Speed Bushing Installer               | 11a. J-22834-1 | Adapter for Seal Installer                |
| 6. J-22875  | 3rd Speed Bushing Installer               | 12. J-23070    | Mainshaft Rear Bearing Lock Nut Installer |
| 7. J-22830  | Snap Ring Installer                       |                |   |

Fig. 3ST—Muncie Transmission Model CH 465 Special Tools



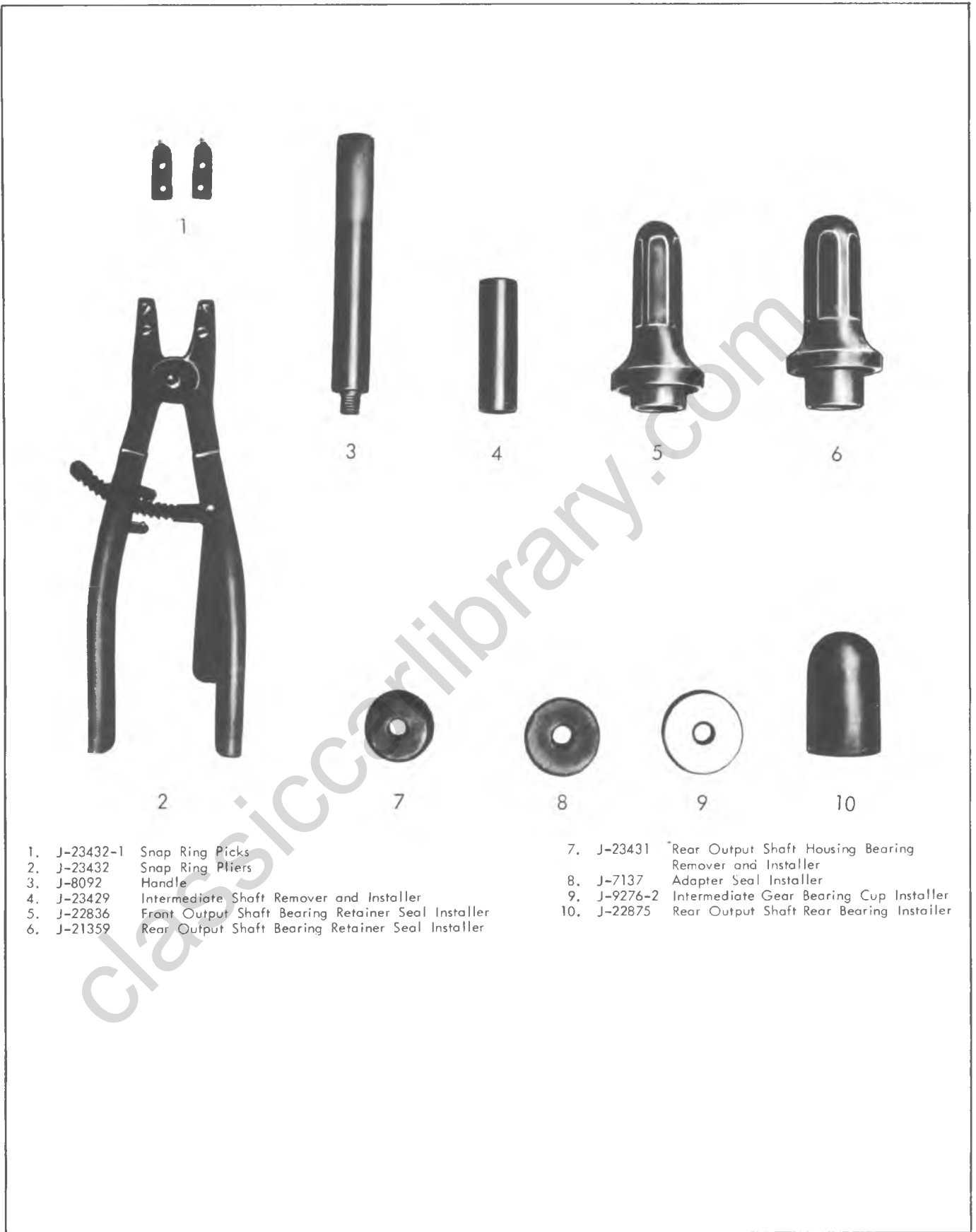
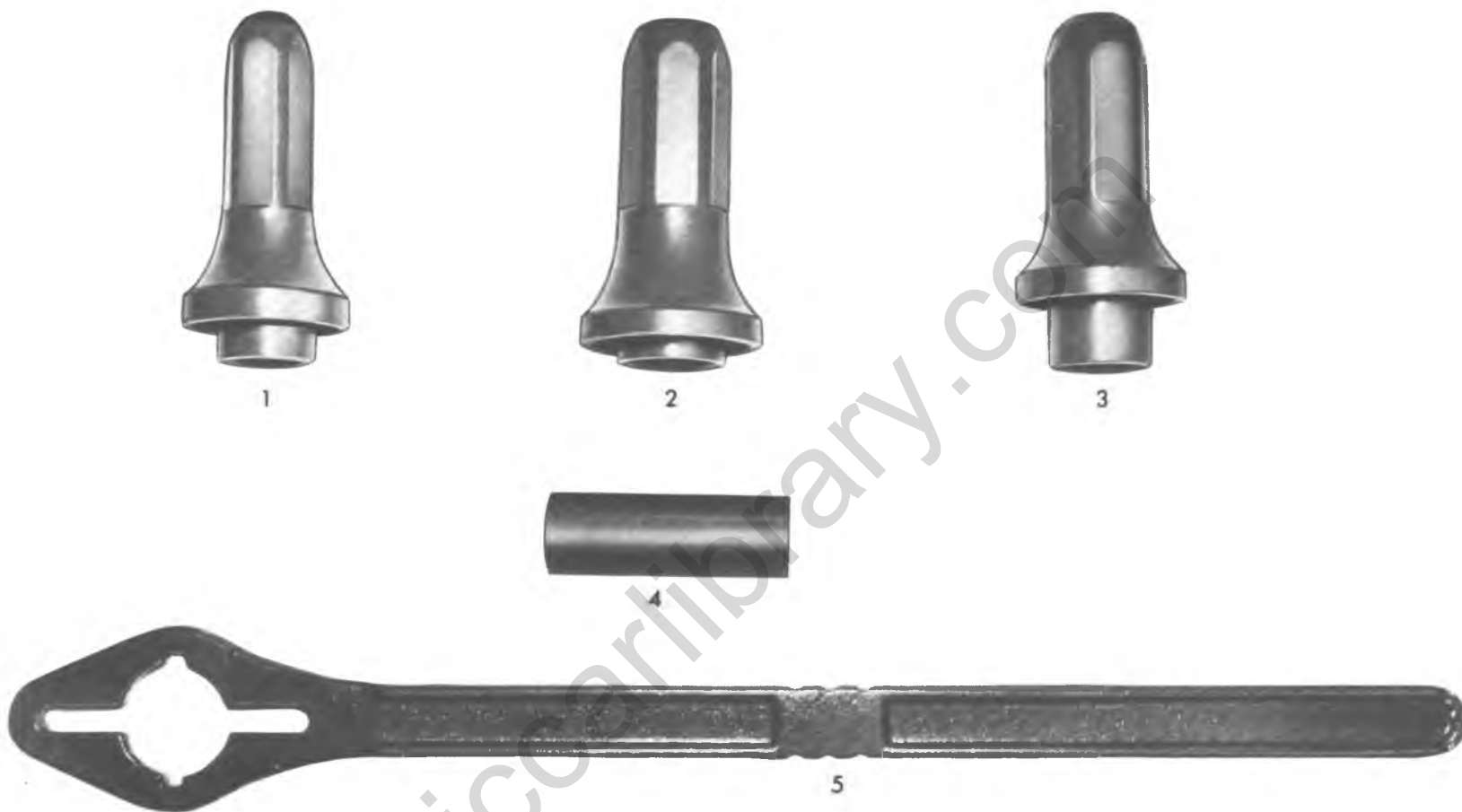
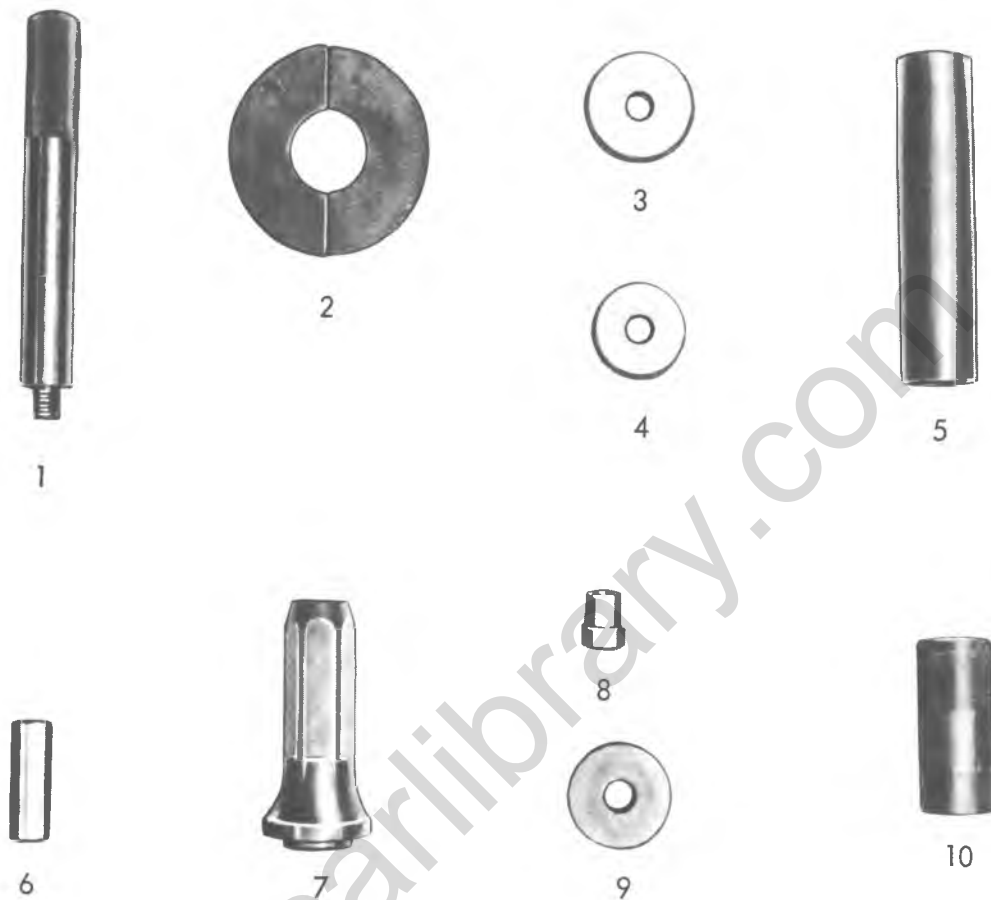

Fig. 4ST—New Process Transfer Case Model 205 Special Tools



1. J-22836 – Front Output Shaft Bearing Retainer Seal Installer
2. J-22388 – Rear Output Shaft Seal Installer
3. J-21359 – Input gear Bearing Retainer Seal Installer
4. J-24745 – Cluster Gear Loading Tool
5. J-8614-1 – Companion Flange Remover

Fig. 5ST—New Process Transfer Case Model 203 Special Tools



- |            |  |
|------------|--|
| 1. J-8092  | Handle.  |
| 2. J-8331  | Rear Output Shaft Front Bearing Remover.       |
| 3. J-23422 | Rear Output Shaft Front Bearing Cup Installer. |
| 4. J-23423 | Rear Output Shaft Rear Bearing Cup Installer.  |
| 5. J-5590  | Bearing Installer.                             |
| 6. J-23419 | Intermediate Shaft Remove and Installer.       |
| 7. J-22833 | Output Shaft Housing Seal Installer.           |
| 8. J-23420 | Pilot Bearing Installer.                       |
| 9. J-7137  | Adapter Seal Installer.                        |
| 10. J-6219 | Front Output Shaft Bearing Installer.          |

Fig. 6ST—Dana Transfer Case Special Tools

classiccarylbrary.com

## SECTION 7A

# AUTOMATIC TRANSMISSION

### CONTENTS OF THIS SECTION

Turbo Hydra-Matic 350 Transmission .....	7A-1
Turbo Hydra-Matic 400/475 Transmission .....	7A-44
Special Tools .....	7A-86

## TURBO HYDRA-MATIC 350 TRANSMISSION

### INDEX

General Description .....	7A-1	Valve Body Assembly .....	7A-33
Theory of Operation .....	7A-2	Manual Shaft, Range Selector Inner Lever and Parking Linkage .....	7A-33
Power Flow .....	7A-2	Transmission Replacement .....	7A-34
Hydraulic System - Functions of Valves and Hydraulic Control Units .....	7A-2	Diagnosis .....	7A-35
Hydraulic Oil System .....	7A-11	Sequence for Diagnosis .....	7A-35
Maintenance and Adjustment .....	7A-28	Fluid Checking Procedures .....	7A-35
Transmission Fluid .....	7A-28	Fluid Leak Diagnosis .....	7A-35
Checking Transmission Mount .....	7A-29	Oil Pressure Check .....	7A-36
Shift Controls .....	7A-29	Case Porosity Repair .....	7A-36
Detent Downshift Cable .....	7A-31	Vacuum Modulator Diagnosis .....	7A-36
Neutral Start Switch .....	7A-31	Clutch Plate Diagnosis .....	7A-38
Service Operations .....	7A-32	Causes of Burned Clutch Plates .....	7A-38
Vacuum Modulator and Modulator Valve .....	7A-32	Governor Pressure Check .....	7A-38
Oil Cooler Pipes .....	7A-32	Manual Linkage .....	7A-38
Governor .....	7A-32	Road Test .....	7A-38
Speedometer Driven Gear .....	7A-33	Trouble Diagnosis .....	7A-39
Speedometer Drive Gear .....	7A-33	Diagnosis Chart .....	7A-40
Extension Housing Oil Seal .....	7A-33		
1-2 Accumulator .....	7A-33		

### GENERAL DESCRIPTION

The Turbo Hydra-Matic 350 transmission is a fully automatic unit consisting primarily of 3-element hydraulic torque converter and two planetary gear sets. Four multiple-disc clutches, two roller clutches, and an intermediate overrun band provide the friction elements required to obtain the desired function of the two planetary gear sets.

The 3-element torque converter consists of a pump, turbine and a stator assembly. The stator is mounted on a one way roller clutch which will allow the stator to turn clockwise, but not counterclockwise. References to clockwise and counterclockwise are determined by looking toward rear of vehicle.

The torque converter is of welded construction and is serviced as a complete assembly. The unit is filled with oil and is attached to the engine crankshaft by a flywheel, thus always rotates at engine speed. The converter pump is an integral part of the converter housing, therefore, the pump blades, rotating at engine

speed, set the oil within the converter into motion and direct it to the turbine, causing the turbine to rotate.

As the oil passes throughout the turbine it is traveling in such a direction that if it were not redirected by the stator it would hit the rear of the converter pump blades and impede its pumping action. So at low turbine speeds, oil is redirected by the stator to the converter pump in such a manner that it actually assists the converter pump to deliver power, or multiply engine torque.

As turbine speed increases, the direction of oil leaving the turbine changes and flows against the rear side of the stator vanes in a clockwise direction. Since the stator is now impeding the smooth flow of oil, its roller clutch releases and it revolves freely on its shaft. Once the stator becomes inactive, there is no further multiplication of engine torque within the converter.

At this point, the converter is merely acting as a fluid coupling as both the converter pump and turbine are being driven at approximately the same speed.

## 7A-2 AUTOMATIC TRANSMISSION

A hydraulic system pressurized by a gear type pump provides the working pressure required to operate the friction elements and automatic controls.

External control connections to the transmission are:

- Manual Linkage - To select the desired operating range.
- Engine Vacuum - To operate the vacuum modulator.
- Cable Control - To operate the detent valve.

A vacuum modulator is used to automatically sense any change in the torque input to the transmission. The

vacuum modulator transmits this signal to the pressure regulator, which controls line pressure, so that all torque requirements of the transmission are met and smooth shifts are obtained at all throttle openings.

The detent valve is activated by a cable that is connected to the accelerator lever assembly. When the throttle is half open, the valve is actuated causing throttle downshift at speeds below 50 mph. When the throttle is fully open the detent valve is actuated causing the transmission to downshift from 3-1 at speeds below 40 mph and 3-2 below 75 mph.

## THEORY OF OPERATION

### POWER FLOW

Refer to figures 1M through 7M for related mechanical power flow. Each figure explains what component is applied or related in each stage of transmission operation.

### HYDRAULIC SYSTEM FUNCTIONS OF VALVES AND HYDRAULIC CONTROL UNITS

#### Pressure Control

The transmission is controlled automatically by a hydraulic system. Hydraulic pressure is supplied by the transmission oil pump, see Figure 8M, which is engine driven. Main line pressure is controlled by a pressure regulator valve train and by the vacuum modulator which is connected to engine vacuum. The pressure regulator valve train controls line pressure automatically, in response to a pressure signal from a modulator valve, in such a way that the torque requirements of the transmission clutches are met and proper shift spacing is obtained at all throttle openings. To control line pressure properly, a modulator pressure is used which varied in the same manner as torque input to the transmission. Modulator pressure is regulated by engine vacuum which is an indicator of engine torque and carburetor opening.

#### Pressure Regulator Valve (Fig. 9M)

1. Regulates line pressure according to a fixed spring force and forces controlled by modulator intermediate and reverse pressure.
2. Controls flow of oil that charges the torque converter, feeds the oil cooler and provides lubrication and oil for clutch applications.

#### Vacuum Modulator Assembly

The engine vacuum signal is provided by the vacuum modulator, which consists of an evacuated metal bellows, a diaphragm and two springs. See Figure 10M. These are so arranged that when installed, the bellows and its external spring apply a force which acts on the modulator valve. This force acts on the modulator valve

so that it increases modulator pressure. Engine vacuum and the other spring acts in the opposite direction to decrease modulator, or low engine vacuum, high modulator pressure; high engine vacuum, and low modulator pressure. To reduce the effect of engine power loss at high altitudes on shift points, the effective area of the diaphragm is made somewhat larger than that of the bellows. Atmospheric pressure then acts on the resulting differential area to reduce modulator pressure.

#### Governor Assembly (Fig. 11M)

The vehicle speed signal to the modulator valve is supplied by the transmission governor, which is driven by the output shaft. The governor consists of a pair of dual weights and a regulator valve.

As the car begins to move the weight assemblies move outward to provide a regulating force against the valve through the springs between the primary and secondary weights. As car speed is further increased, regulating force against the valve is provided by the secondary weights moving outward. At approximately 22 MPH the primary weights have reached the limit of their travel and the force against the valve is then entirely through the secondary weights.

Thus, governor valve pressure is determined at very low speeds by the primary and secondary weights and at higher speeds by the secondary weights plus the force of the springs between the weights. In this manner governor pressure is increased rapidly but smoother from very low speeds to approximately 22 MPH, where it increases at a slower rate.

#### Manual Valve (Fig. 12M)

Establishes the range of transmission operation i.e. P, R, N, D, L1, L2, as selected by the vehicle operator through the manual selector lever.

#### Modulator Valve (Fig. 10M)

Regulates line pressure to modulator pressure that varies with torque to the transmission. It senses forces created by:

## PARK OR NEUTRAL

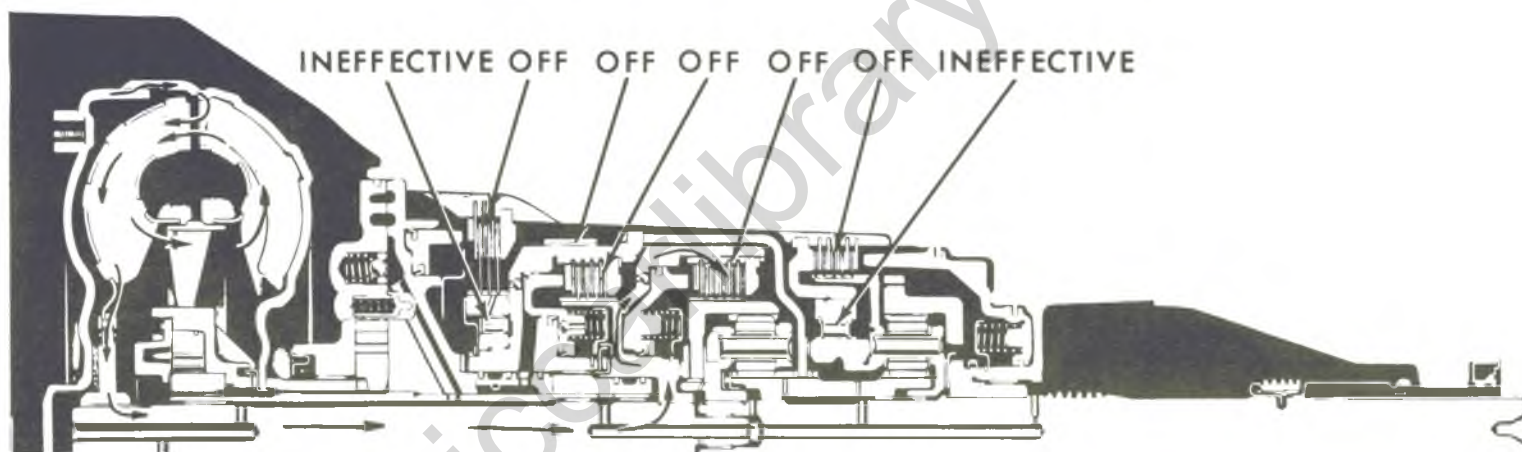

Intermediate Clutch - OFF

Direct Clutch - OFF

Forward Clutch - OFF

Low & Reverse Clutch - OFF

Intermediate Overrun Roller Clutch - INEFFECTIVE

Low and Roller Clutch - INEFFECTIVE

Intermediate Overrun Band - OFF

In park and neutral, all clutches and the intermediate overrun band are released: therefore no power is transmitted from the torque converter turbine to planetary gear sets or output shaft.

Fig. 1M—Power Flow in Neutral Range - Typical

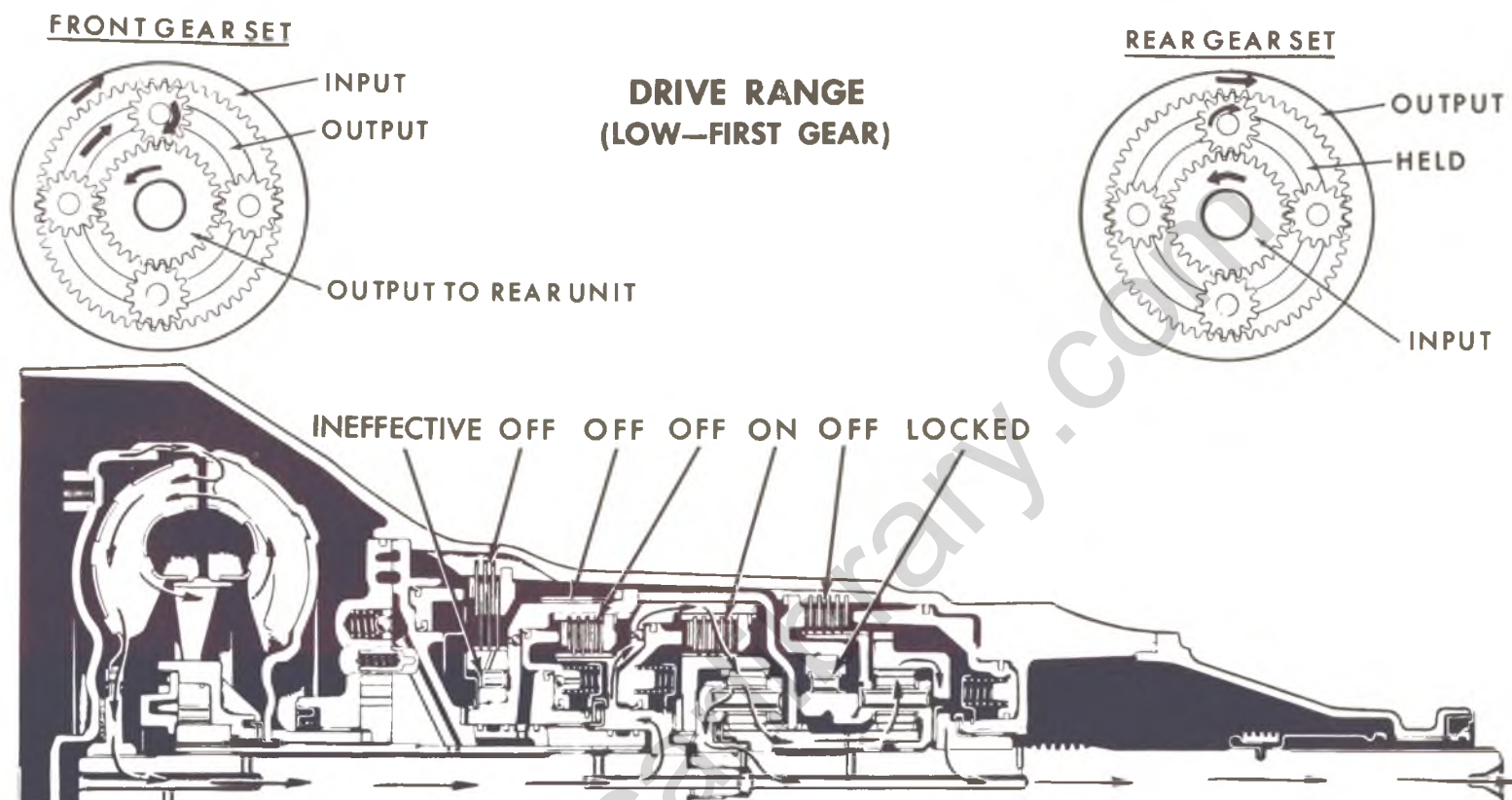

With the range selector lever in Drive "D" range, the forward clutch is applied. This delivers turbine torque from the input shaft through the forward clutch, to the input ring gear in a clockwise direction. (Converter torque ratio equals approximately 2:00 at stall)

Clockwise rotation of the input ring gear causes the output planet pinions to rotate in a clockwise direction, driving the sun gear counterclockwise. In turn, the sun gear turns causing the reaction carrier planet pinions to turn clockwise. Clockwise rotation of the reaction carrier planet pinions causes the output ring gear and output shaft to turn in a clockwise direction in a reduction ratio of approximately 2.52 to 1. The reaction of the reaction carrier planet pinions against the output ring gear is taken by the low and roller clutch which is grounded to the case.

Fig. 2M—Power Flow in Drive Range - Low (First Gear) - Typical



**FRONT GEAR SET**

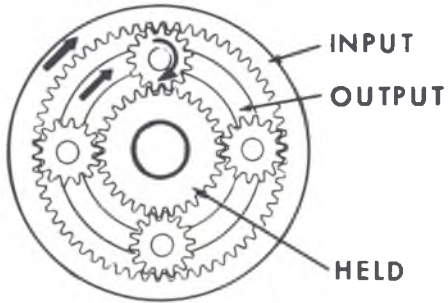

**DRIVE RANGE  
(INTERMEDIATE—SECOND GEAR)**

**REAR GEAR SET**

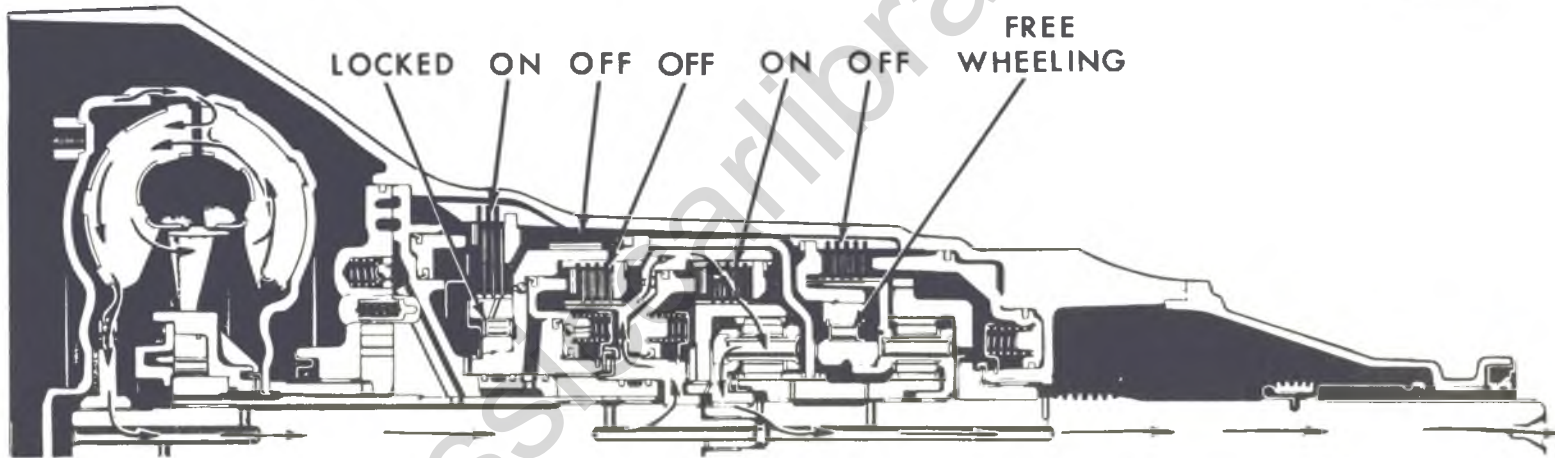
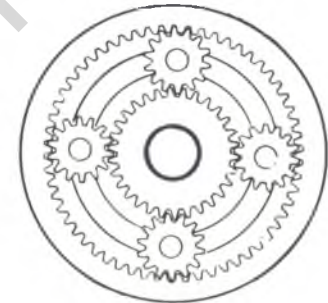

Intermediate Clutch - ON      Direct Clutch - OFF      Forward Clutch - ON      Low and Reverse Clutch - OFF  
 Intermediate Overrun Roller Clutch - LOCKED      Low and Roller Clutch - FREEWHEELING  
 Intermediate Overrun Band - OFF

In Drive "D" range intermediate, (second gear) the intermediate clutch is applied to allow the intermediate overrun roller clutch to hold the shell and sun gear stationary (against counterclockwise rotation.) Turbine torque, through the applied forward clutch is delivered to the input ring gear in a clockwise direction. Clockwise rotation of the input ring gear causes the output planet pinions to walk around the stationary sun gear in a clockwise direction. This causes the output shaft to turn in a clockwise direction in a reduction ratio of approximately 1.52 to 1.

Fig. 3M—Power Flow in Drive Range - Intermediate (2nd Gear) - Typical

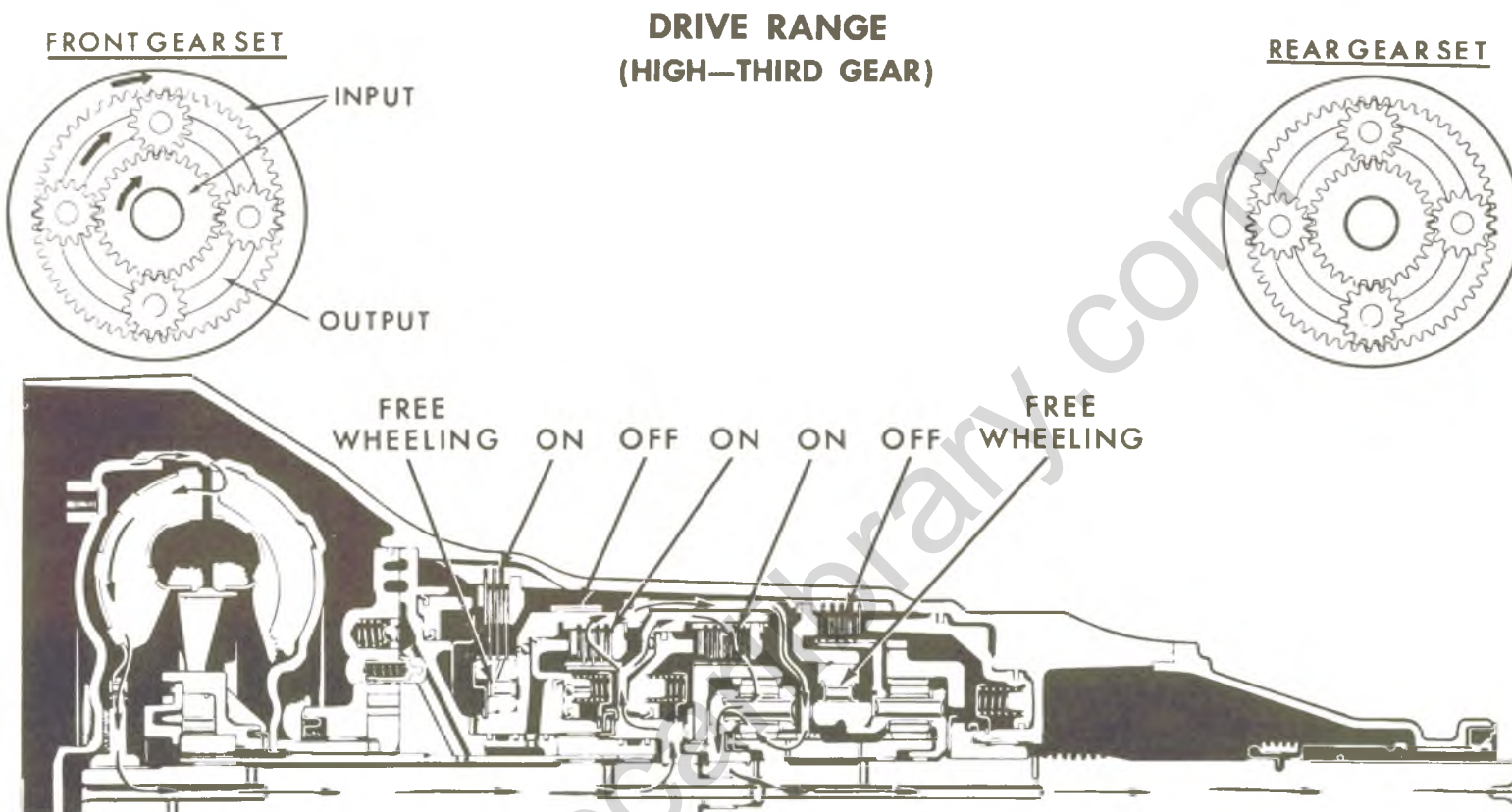

Intermediate Clutch - ON

Direct Clutch - ON

Forward Clutch - ON

Low and Reverse Clutch - OFF

Intermediate Overrun Roller Clutch - FREE WHEELING

Low and Roller Clutch - FREE WHEELING

Intermediate Overrun Band - OFF

In direct drive, engine torque is transmitted to the converter then through the forward clutch, to the input ring gear in clockwise direction the direct clutch is applied transmitting torque through the sun gear drive shell to the sun gear in a clockwise direction. Since both the sun gear and the planet pinion gears are both turning in a clockwise direction at the same speed, the planetary gear sets are locked and turn as one unit in direct drive or at a ratio of 1:1.

Fig. 4M—Power Flow in Drive Range - Direct (Third Gear) - Typical



**L<sub>1</sub> RANGE  
(MANUAL FIRST GEAR)**

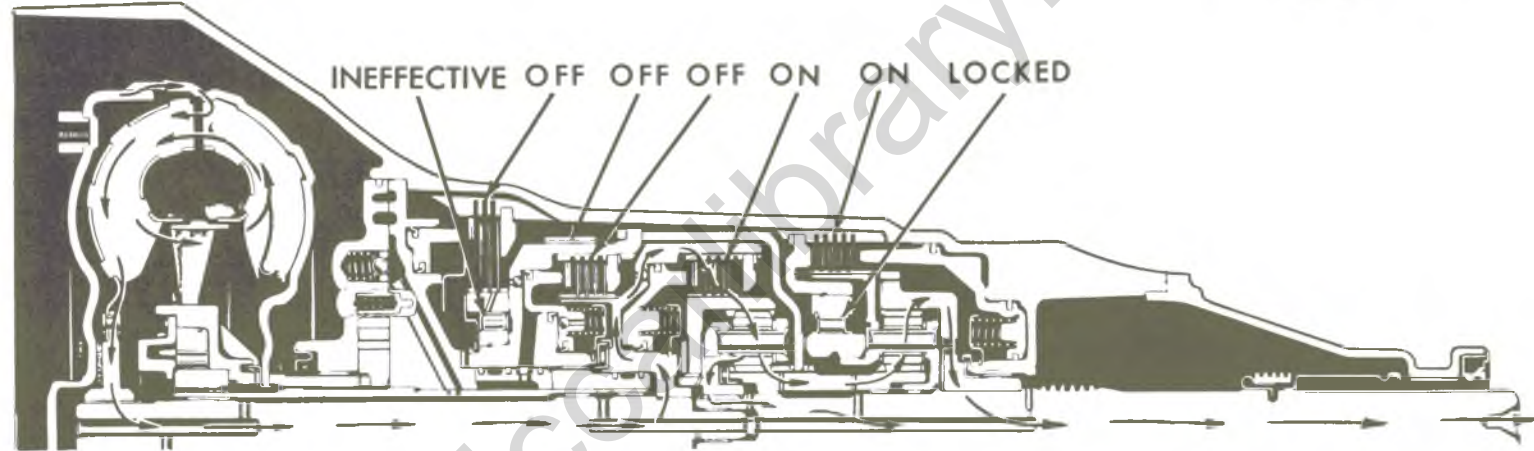

- Intermediate Clutch - OFF
- Direct Clutch - OFF
- Forward Clutch - ON
- Low and Reverse Clutch - ON
- Intermediate Overrun Roller Clutch - INEFFECTIVE
- Low and Roller Clutch - LOCKED
- Intermediate Overrun Band - OFF

With the range selector lever in L<sub>1</sub> range, the forward clutch is applied. This delivers turbine torque from the input shaft through the forward clutch, to the input ring gear in clockwise direction. (Converter torque ratio equals approximately 2:00 at stall.)

Clockwise rotation of the input ring gear causes the output planet pinions to rotate in a clockwise direction, driving the sun gear counter-wise. In turn, the sun gear turns, causing the reaction carrier planet pinions to turn clockwise. Clockwise rotation of the reaction carrier planet pinions causes the output ring gear and output shaft to turn in a clockwise direction in a reduction ratio of approximately 2:52 to 1. The reaction of the reaction carrier planet pinions against the output ring gear is taken by either the low and roller clutch or the low & reverse clutch which are grounded to the case.

When the transmission is shifted into L<sub>1</sub> (first gear), the low and reverse clutch is applied below a preset controlled speed in addition to the forward clutch which is on for all forward ranges. The low and reverse clutch provides overrun braking as it holds the reaction carrier fixed.

Fig. 5M—Power Flow in L<sub>1</sub> Range (Manual First Gear) - Typical

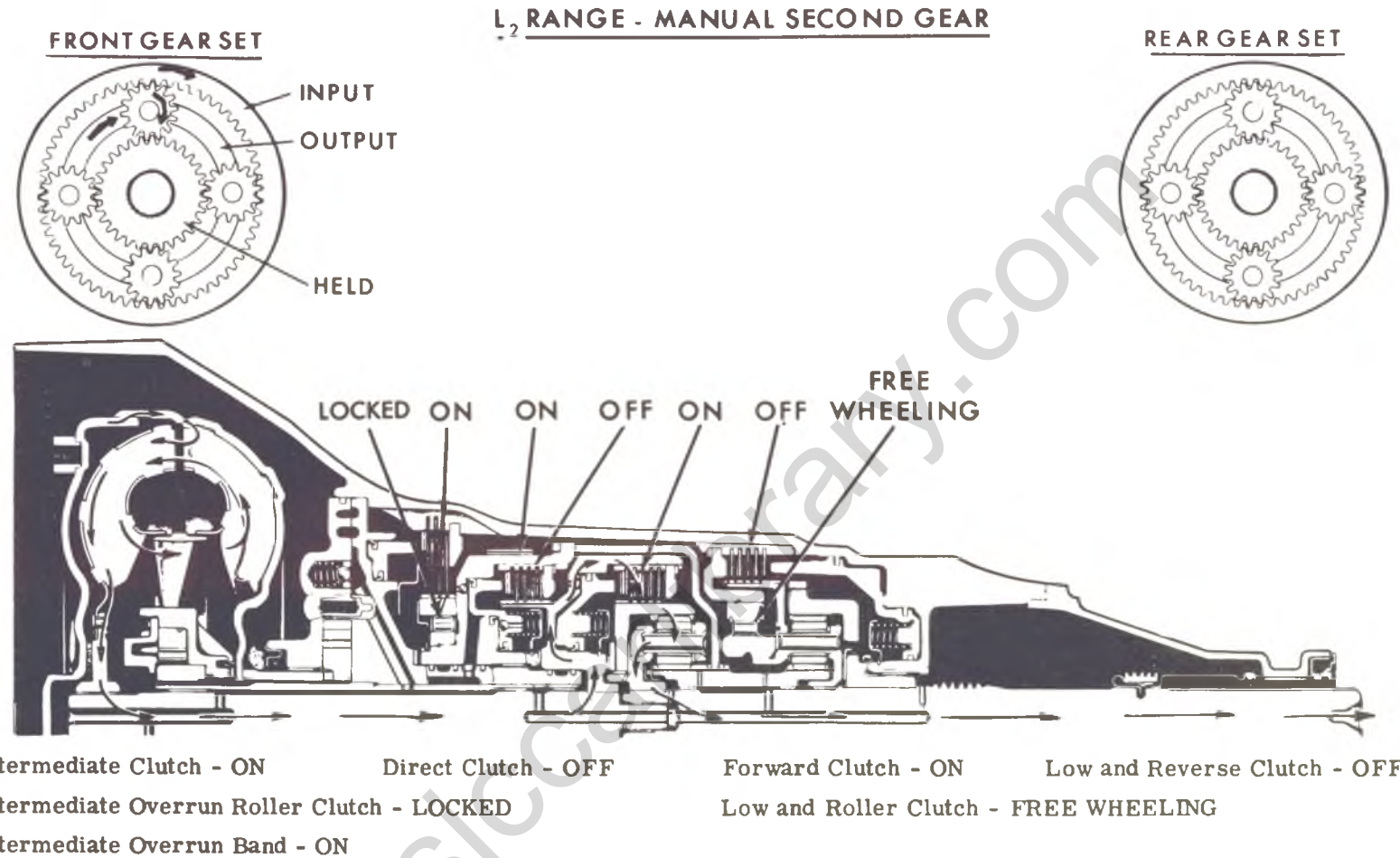

In L<sub>2</sub> range intermediate, the intermediate clutch is applied to allow the intermediate overrun roller clutch to hold the shell and sun gear stationary (against counterclockwise rotation). Turbine torque, through the applied forward clutch is delivered to the input ring gear in a clockwise direction. Clockwise rotation of the input ring gear causes the output planet pinions to walk around the stationary sun gear in a clockwise direction. This causes the output ring gear and output shaft to turn in a clockwise direction in a reduction ratio of approximately 1:52 to 1. The reaction of the output planet pinions against the sun gear is taken by either the intermediate overrun roller clutch or the intermediate overrun band. When the transmission is shifted into L<sub>2</sub> (second gear), the intermediate overrun band is applied in addition to the forward and intermediate clutches. The intermediate overrun band provides overrun braking as it holds the sun gear fixed.

Fig. 6M—Power Flow in L<sub>2</sub> Range (Manual Second Gear) - Typical

**FRONT GEAR SET**

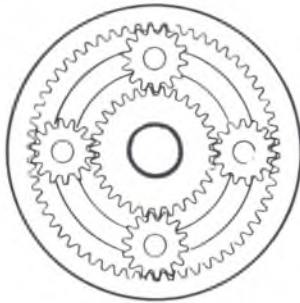

**REVERSE**

**REAR GEAR SET**

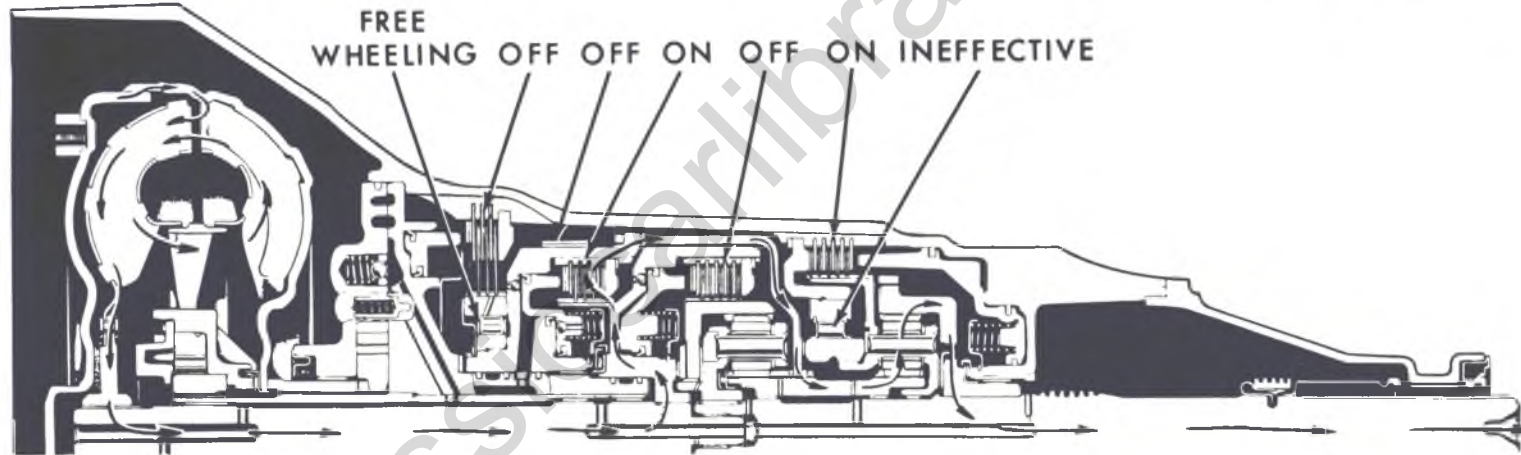
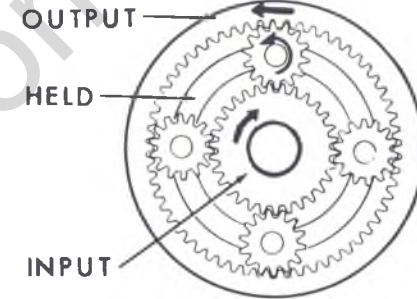

Intermediate Clutch - OFF      Direct Clutch - ON      Forward Clutch - OFF      Low & Reverse Clutch - ON  
 Intermediate Overrun Roller Clutch - INEFFECTIVE      Low and Roller Clutch - INEFFECTIVE  
 Intermediate Overrun Band - OFF

In Reverse "R", the direct clutch is applied to transmit torque from the forward clutch housing to the sun gear drive shell and the sun gear. The low and reverse clutch is applied preventing the output carrier from turning. Clockwise rotation of the sun gear causes the reaction carrier pinions to turn counterclockwise, thus turning the output ring gear and output shaft counterclockwise in a reduction ratio of approximately 1.93 to 1.

Fig. 7M—Power Flow in Reverse Range - Typical

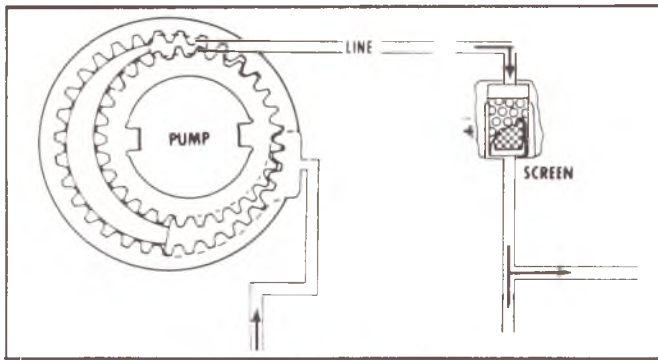

Fig. 8M—Oil Pump

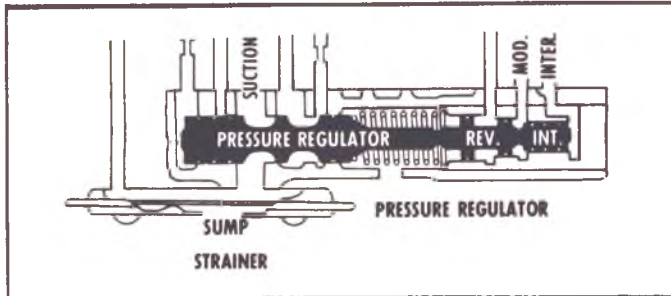
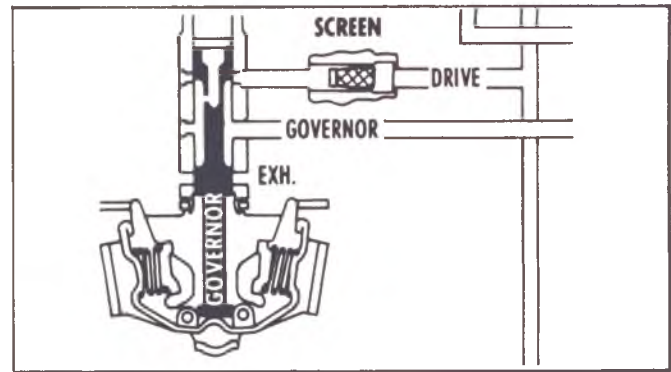

Fig. 9M—Pressure Regulator Valve

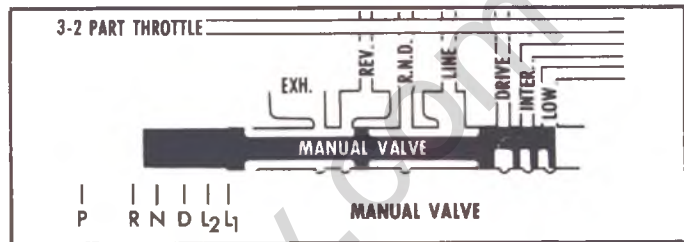

Fig. 12M—Manual Valve

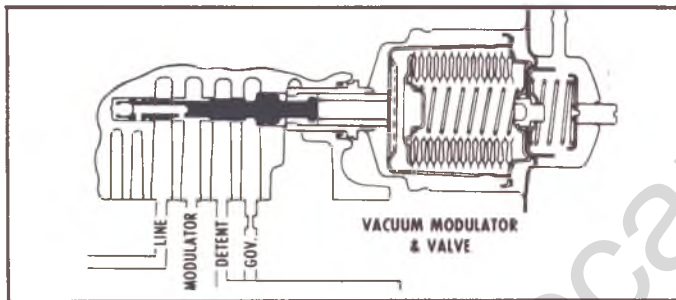

Fig. 10M—Vacuum Modulator Assembly

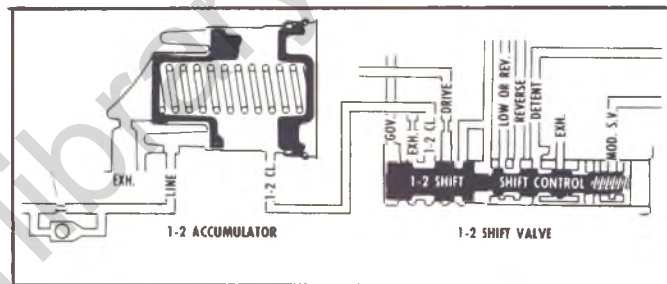

Fig. 13M—1-2 Shift Valve and Accumulator

1. The vacuum modulator bellows that increases modulator pressure.
2. Engine vacuum acting on a diaphragm to decrease modulator pressure.
3. Governor pressure which is generated by the governor assembly. Governor pressure tends to decrease modulator pressure.

### 1-2 Accumulator (Fig. 13M)

Line pressure routed to the 1-2 accumulator causes the piston to cushion application of the intermediate clutch. The spring within the accumulator acts against the piston. The force of the spring and the pressure of the 1-2 clutch oil push the 1-2 accumulator piston back towards the line oil to allow a gradual build up of the 1-2 clutch pressure.

### 1-2 Shift Valve (Fig. 13M)

Routes oil pressure that causes the transmission to shift from 1-2 or 2-1. Its operation is controlled by governor pressure, detent pressure, modulator pressure, and spring force. See Figure 13M.

### 2-3 Accumulator (Fig. 14M)

Oil routed to the 2-3 accumulator cushions the application of the direct clutch. The spring within the accumulator acts against the piston. The force of the spring and the pressure of the 2-3 clutch oil push the 2-3 accumulator piston back towards the R, D, N oil to allow a gradual build up of the 2-3 clutch pressure.

### 2-3 Shift Valve (Fig. 14M)

Routes oil pressure that causes the transmission to shift from 2-3 or 3-2. Its operation is controlled by modulator, governor, detent and modulator, valves pressures as well as a spring force.

### Detent Valve (Actuated by Cable Linkage From Throttle Linkage)

Affects regulated modulator pressure tending to hold the 1-2 shift and 2-3 shift valves in the downshift position and provides areas for modulator and detent regulated pressures for detent 2-1, 3-1, and 3-2 downshifts.

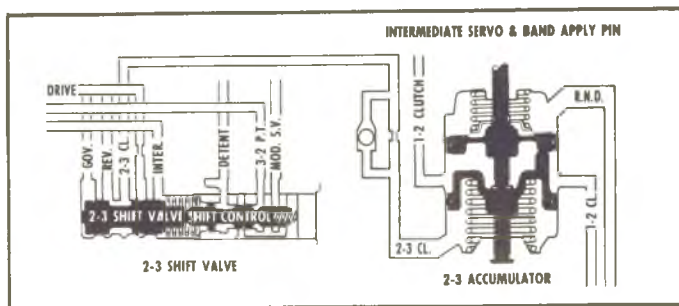

Fig. 14M—2-3 Shift Valve and Accumulator

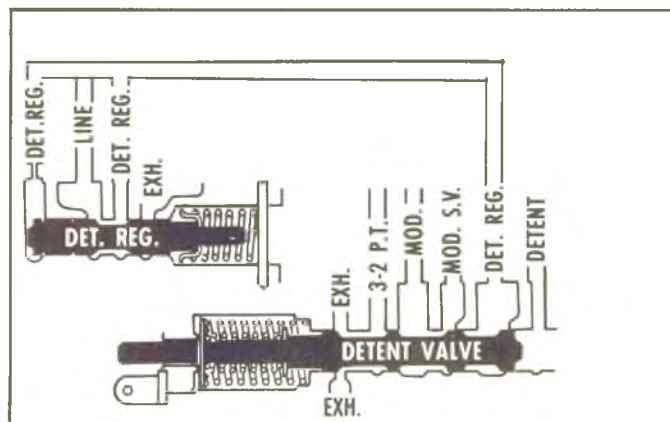

Fig. 15M—Detent Valve and Pressure Regulator Valve

**Detent Pressure Regulator Valve (Fig. 15M)**

The detent pressure regulator valve and spring regulate line pressure into detent regulator oil which is used to control the car speed at which the 1-2 and 2-3 upshifts occur.

**Cooler By-Pass Valve (Fig. 16M)**

The cooler by-pass valve permits oil to be fed directly from the converter to the lubrication circuit when the oil is very cold or if the cooler or lines would become restricted.

**Manual Low Control Valve (Fig. 17M)**

The manual low control valve is positioned to exhaust the manual low apply line when the manual valve is placed in the manual low (L1) position above approximately 50 MPH. At speeds below 50 MPH low oil is fed into the manual low apply line which move the 1-2 shift valve to the downshifted position (exhausting the 1-2 clutch) and moves the 1-2 shift control valve to the upshifted position which sends low apply oil to the low and reverse clutch which engages this clutch. Once the manual low control valve is in the downshifted position, its spring plus low apply oil acting on it will keep it in

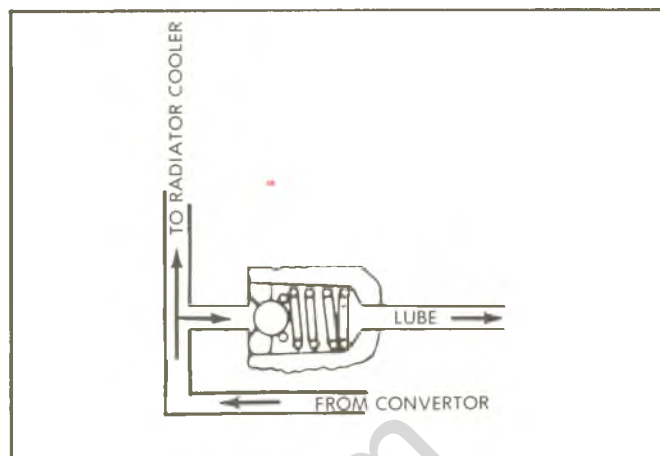

Fig. 16M—Cooler By-Pass Valve

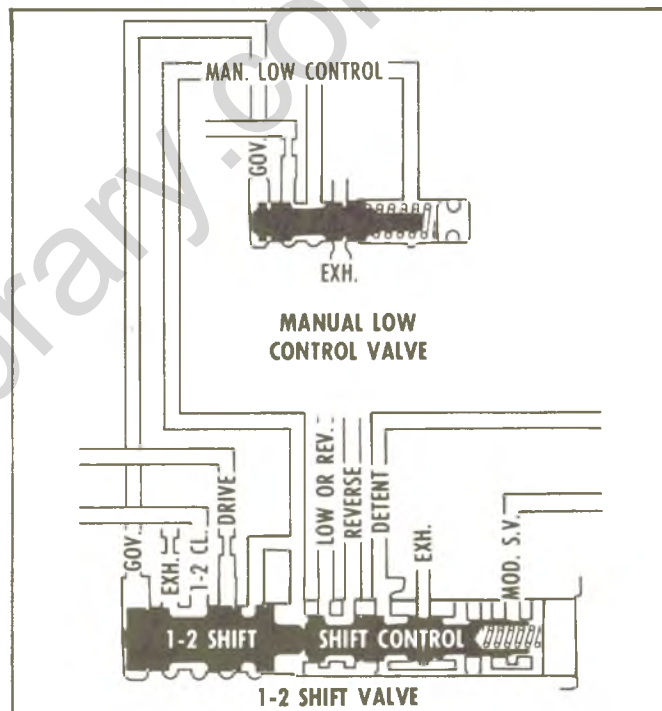

Fig. 17M—Manual Low Control Valve

this position; therefore, with the transmission in manual low (L1 range), the transmission cannot upshift to intermediate (second gear) regardless of vehicle or engine speed once low gear has been engaged.

The manual low control valve is used also to protect the engine by preventing low range engagement (indicated by high car speed which is sensed by high governor pressure) at car speeds over 50 MPH.

**HYDRAULIC OIL SYSTEM**

Refer to Figures 18M through 25M for explanation of hydraulic system that applies the clutches and bands and controls the automatic shifting.

NOTE: All pressures, MPH and RPM are approximate and are to be used for illustrating hydraulic operation only.

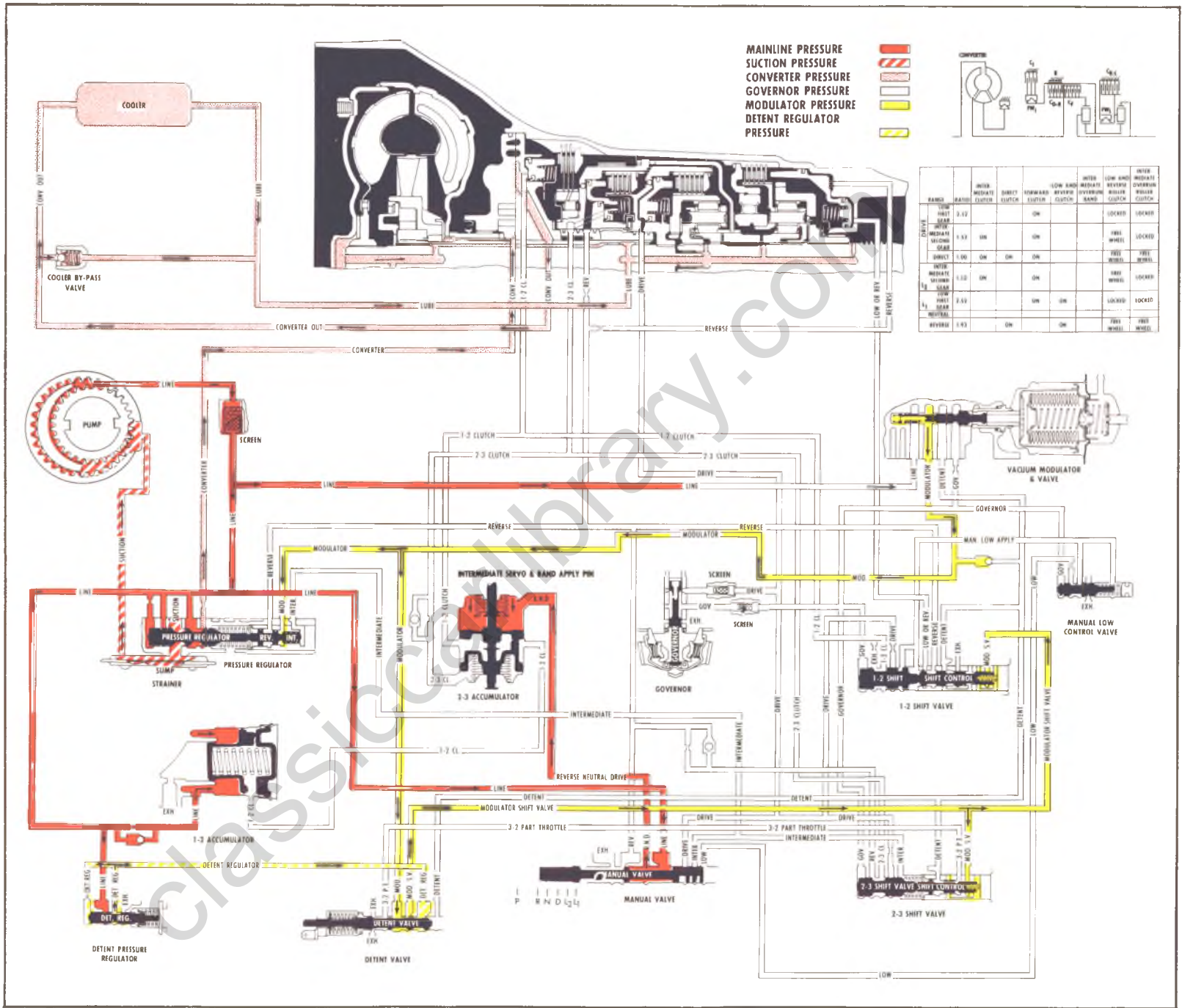

Fig. 18M—Neutral - Engine Running - Typical



## NEUTRAL – ENGINE RUNNING

Intermediate Clutch - OFF  
Direct Clutch - OFF  
Forward Clutch - OFF  
Low and Reverse Clutch - OFF

Intermediate Overrun Roller Clutch - FREE WHEELING  
Low and Reverse Roller Clutch - FREE WHEELING  
Intermediate Overrun Band - OFF

Whenever the engine is running at idle with the selector lever in neutral, oil from the pump is directed to—

1. Pressure Regulator Valve
2. Converter (With Pressure Regulator Valve regulating)
  - a. Cooler By-pass Valve
  - b. Oil Cooler
  - c. Lubrication System.
3. Manual Valve
4. Modulator Valve
5. 2-3 Accumulator (Neutral - Not In Park)
6. Detent Pressure Regulator
7. 1-2 Accumulator

### Cooling and Lubrication

Oil flows from the pump to the pressure regulator valve which regulates the pump pressure. When pump output exceeds the demand of line pressure, oil from the pressure regulator valve is directed to the converter feed passage to fill the converter. Converter return oil is directed to the cooler by-pass valve and trans-

mission cooler. Oil from the cooler is directed to the transmission lubrication system. The cooler by-pass valve permits oil to be fed directly from the converter to the lubrication circuit if the cooler should become restricted.

From the pressure regulator valve line oil is then routed as follows—

1. Manual Valve
2. 2-3 Accumulator
3. Detent Pressure Regulator
4. 1-2 Accumulator
5. Vacuum Modulator Valve

Line pressure at the modulator valve is regulated to modulator oil which acts on the modulator and reverse boost valve, detent valve, 2-3 shift control valve, and the 1-2 shift control valve.

### Summary

The converter is filled, all clutches and bands are released. The transmission is in neutral.

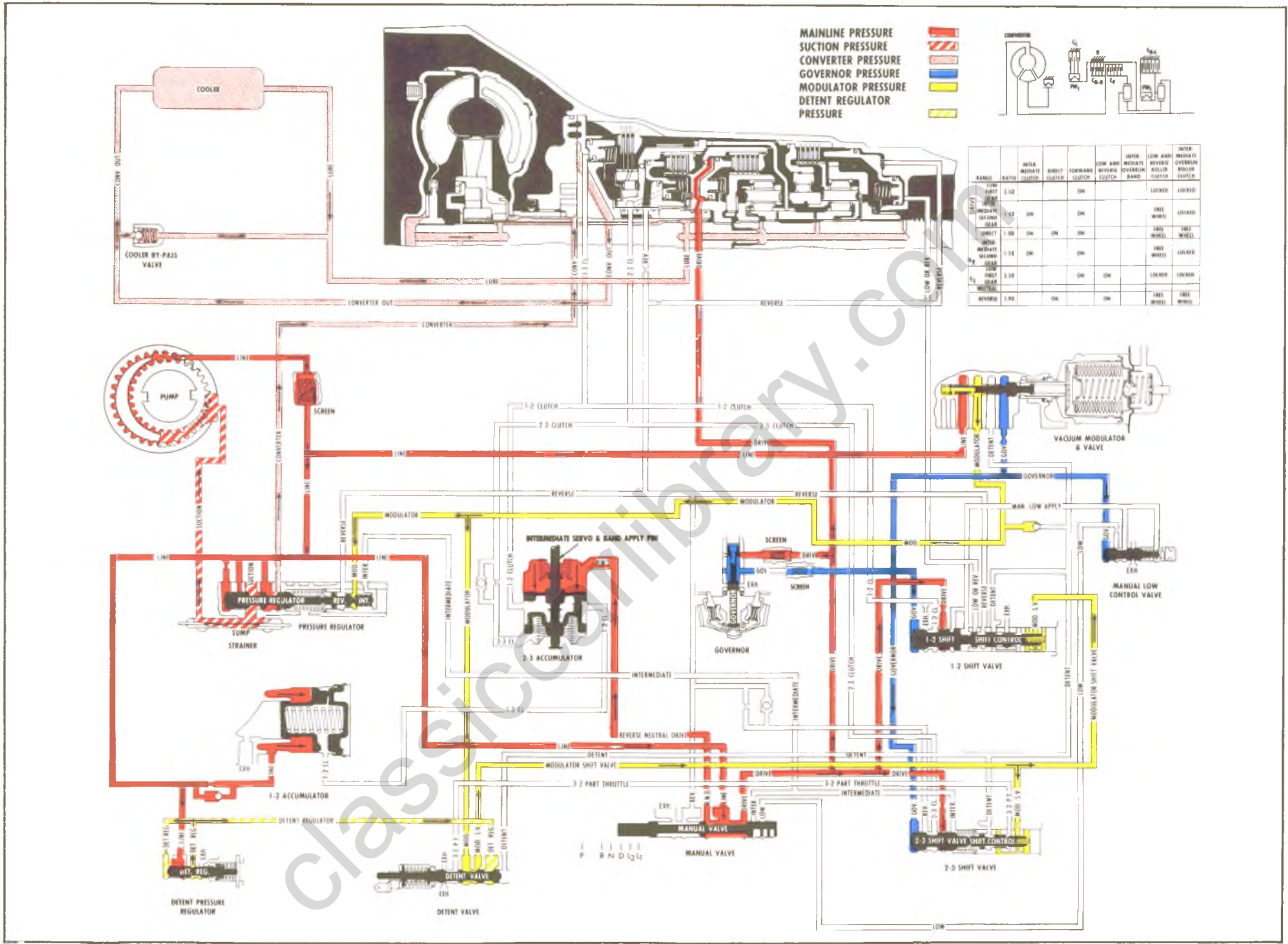

Fig. 19M—Drive Range - Low (First Gear) - Typical

## DRIVE RANGE – LOW (FIRST GEAR)

Intermediate Clutch - OFF  
Direct Clutch - OFF  
Forward Clutch - ON  
Low and Reverse Clutch - OFF

Intermediate Overrun Roller Clutch - INEFFECTIVE  
Low and Reverse Roller Clutch - LOCKED  
Intermediate Overrun Band - OFF

Line pressure is fed to the:

1. Modulator Valve
2. 1-2 Accumulator Piston
3. Detent Pressure Regulator Valve
4. Manual Valve

From the manual control valve line pressure forms drive oil and is fed to the:

1. Forward Clutch
2. Governor
3. 1-2 Shift Valve
4. 2-3 Shift Valve
5. Intermediate Servo (as R.N.D. oil)

### Basic Control

When the selector lever is moved to the drive position, the manual valve

directs line pressure to the R.N.D. and drive ports. R.N.D. pressure strokes the 2-3 accumulator so that it is prepared to cushion the 2-3 clutch for an upshift. The 1-2 accumulator has already been stroked with line oil to prepare it to cushion the 1-2 clutch.

Drive oil applies the forward clutch, feeds the governor and also the 1-2 and 2-3 shift valves.

### Summary

Drive oil is directed to the forward clutch and is regulated to a variable pressure called governor pressure at the governor assembly.

Governor pressure increases with speed and acts against the ends of the 1-2 and 2-3 shift valves, and the modulator valve.

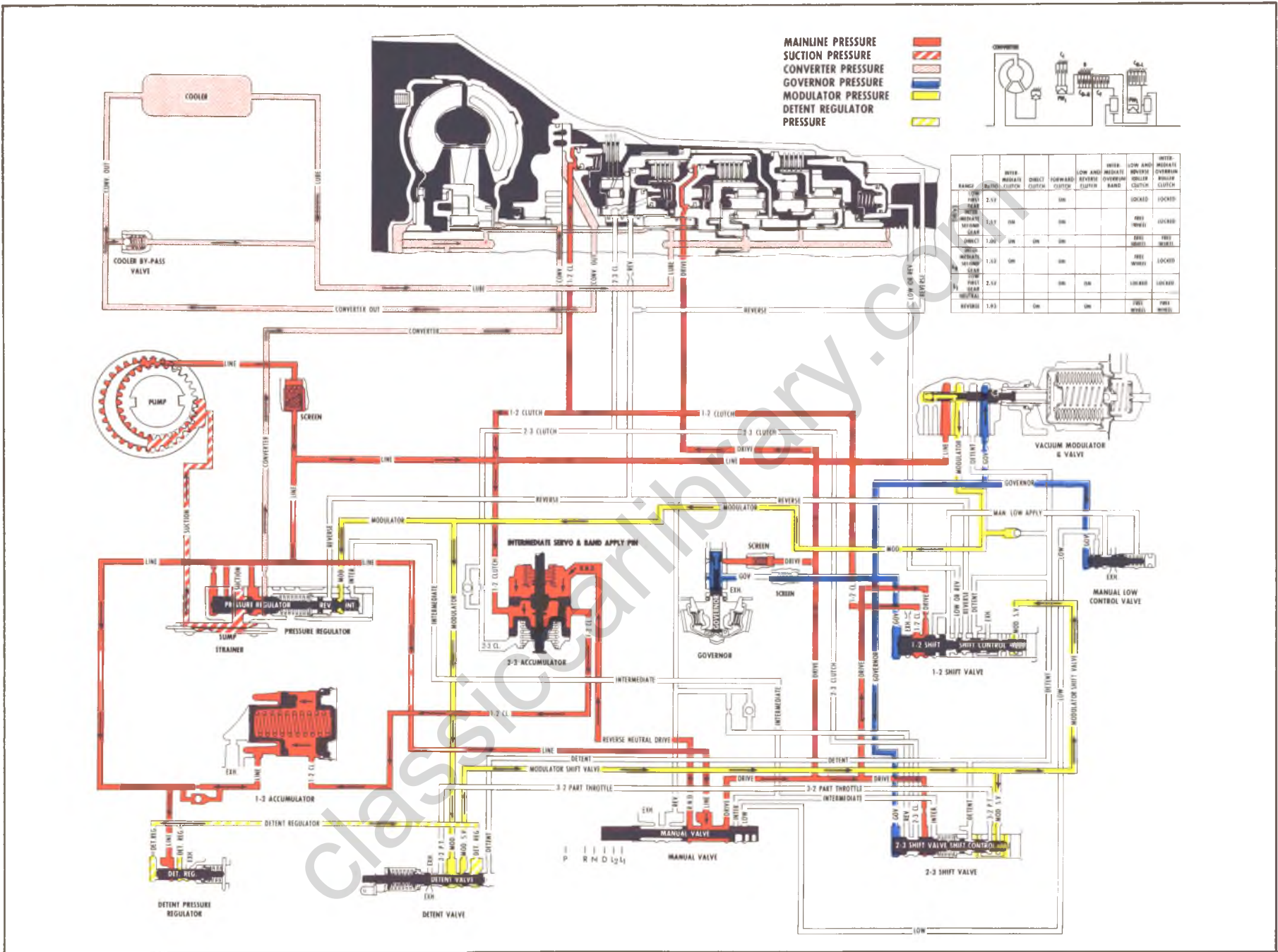

Fig. 20M- Drive Range - Intermediate (Second Gear) Typical

## DRIVE RANGE – INTERMEDIATE (SECOND GEAR)

Intermediate Clutch - ON  
Direct Clutch - OFF  
Forward Clutch - ON  
Low and Reverse Clutch - OFF

Intermediate Overrun Roller Clutch - LOCKED  
Low and Roller Clutch - FREE WHEELING  
Intermediate Overrun Band - OFF

As both vehicle speed and governor pressure increase, the force of governor pressure (46 PSI @ W.O.T.) acting on the 1-2 shift valve overcome the force of the 1-2 shift valve spring and modulator oil regulated by the modulator valve. This allows the 1-2 shift valve to move to the upshifted position which directs drive oil to apply the intermediate clutch. Oil in this passage is called (1-2) clutch oil.

Intermediate (1-2) clutch oil from the 1-2 shift valve is directed to:

1. Intermediate Clutch
2. 2-3 Accumulator
3. 1-2 Accumulator

### Basic Control

Intermediate clutch oil flows from the 1-2 shift valve through the 2-3 accumulator. And then to the 1-2 accumulator which cushions intermediate clutch application. The 1-2 accumulator has clutch apply pressure and a calibration spring acting on one side with line pressure on the other side.

### Summary

The forward and intermediate clutch are applied. The transmission is in drive range 2nd gear. When in drive range the full throttle 1-2 upshift will occur at approximately 50 MPH and minimum throttle 1-2 upshift will occur at approximately 12 MPH.

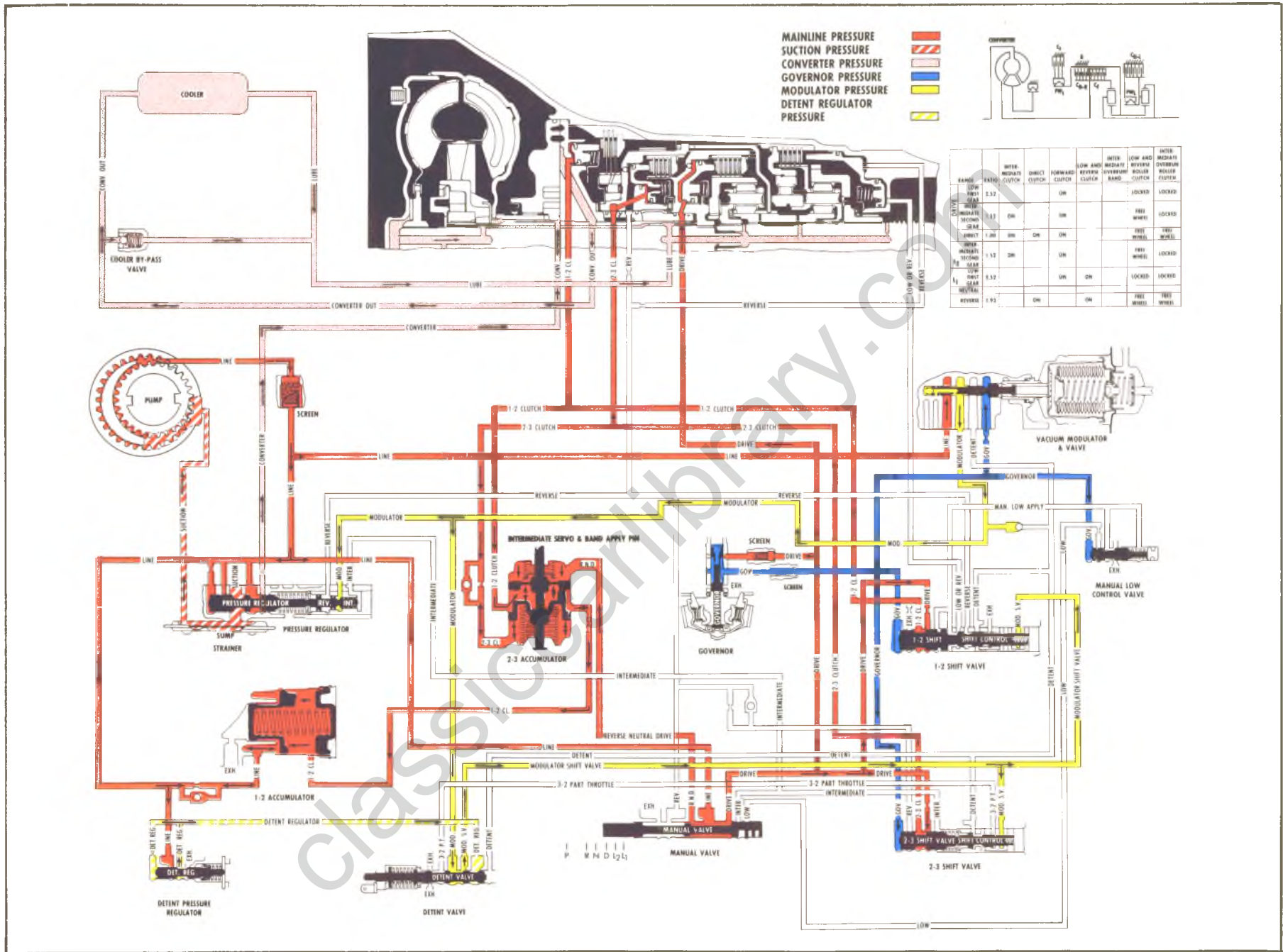

Fig. 21M—Drive Range · Direct (Third Gear) · Typical

## DRIVE RANGE – DIRECT (THIRD GEAR)

Intermediate Clutch - ON  
Direct Clutch - ON  
Forward Clutch - ON  
Low and Reverse Clutch - OFF

Intermediate Overrun Roller Clutch - FREE WHEELING  
Low and Roller Clutch - FREE WHEELING  
Intermediate Overrun Band - OFF

As vehicle speed and governor pressure increases, the force of the governor pressure (83 PSI @ W.O.T.) acting on the 2-3 shift valve overcomes the force of the 2-3 shift valve spring and modulator oil. This allows the 2-3 shift valve to move to the upshifted position feeding drive oil to the direct clutch. This oil is called 2-3 (direct) clutch oil.

Direct (2-3) clutch oil is directed from the 2-3 shift valve to:

1. Direct Clutch
2. 2-3 Accumulator

### Basic Control

Direct (2-3) clutch oil from the 2-3 shift valve flows to the direct clutch and

also to the 2-3 accumulator piston. The shift is cushioned by the R.N.D. oil force on the other side of the accumulator pistons.

### Summary

The forward, intermediate and direct clutches are applied. The transmission is in drive range - third gear (direct drive).

When in drive range the full throttle 2-3 upshift will occur at approximately 85 MPH and minimum throttle 2-3 upshifts will occur at approximately 22 MPH.

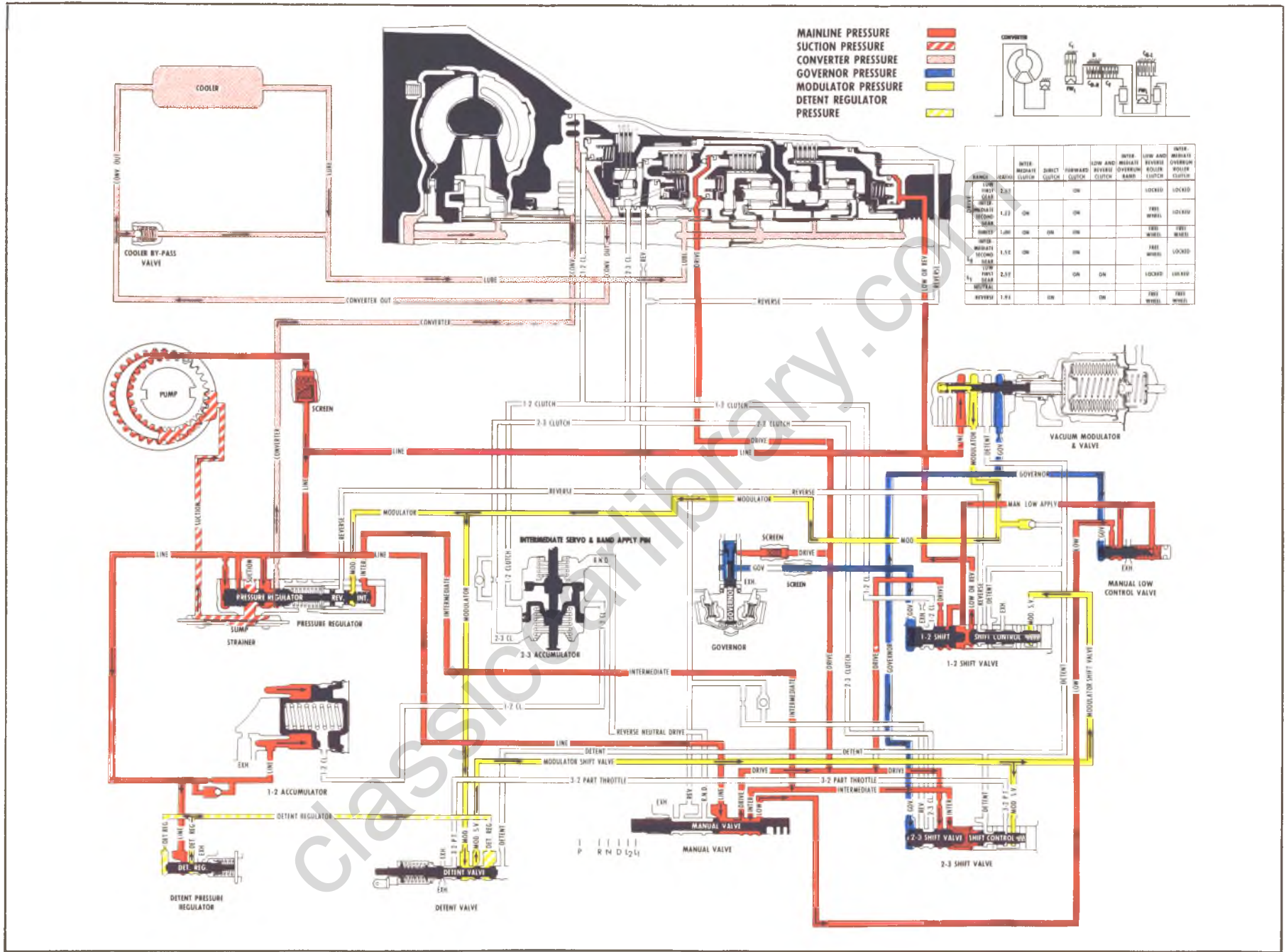

Fig. 22M-L1 Range - Manual First Gear - Typical



## L<sub>1</sub> RANGE – MANUAL FIRST GEAR

Intermediate Clutch - OFF  
Direct Clutch - OFF  
Forward Clutch - ON  
Low and Reverse Clutch - ON

Intermediate Overrun Roller Clutch - INEFFECTIVE  
Low and Reverse Roller Clutch - LOCKED  
Intermediate Overrun Band - OFF

Maximum downhill braking can be attained at speeds below approximately 50 MPH with the selector lever in L<sub>1</sub> range position. Low range oil from the manual valve is then directed to the manual low control valve which in turn directs it through the 1-2 shift valve train to the low and reverse clutch piston (inner area only).

### Basic Control

The manual low control valve is positioned to exhaust the manual low apply line when the manual valve is placed in the manual (L<sub>1</sub>) position above approximately 50 MPH. At speeds below 50 MPH low oil is fed into the manual low apply line which moves the 1-2 shift valve to the downshifted position (exhausting the 1-2 clutch) and moves the 1-2 shift control valve to the upshifted position which sends low apply oil to the low and reverse clutch which engages

this clutch. Once the manual low control valve is in the downshifted position, its spring plus low apply oil acting on it will keep it in this position; therefore, with the transmission in manual low (L<sub>1</sub> range), the transmission cannot upshift to intermediate (second gear) regardless of vehicle or engine speed once low gear has been engaged.

### Summary

The forward clutch and the low and reverse clutch are applied. The transmission is in low (first gear) L<sub>1</sub> range.

The manual low control valve is used also to protect the engine by preventing low range engagement (indicated by high speed which is sensed by high governor pressure) at speeds over 50 MPH, or approximately 3600 engine rpm.

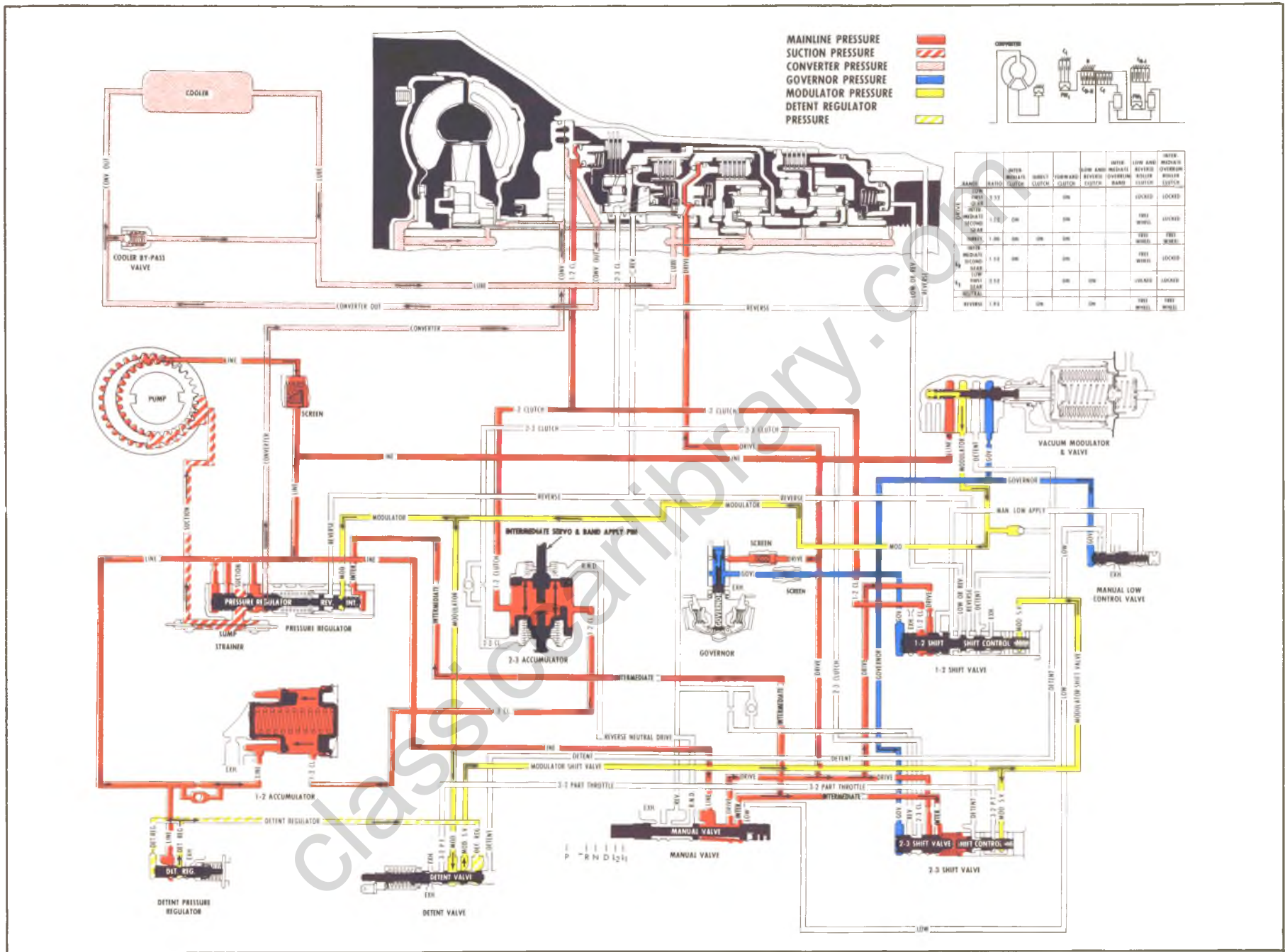

Fig. 23M-L2 Range - Manual Second Gear Typical

## L<sub>2</sub> RANGE – MANUAL SECOND GEAR

Intermediate Clutch - ON  
Direct Clutch - OFF  
Forward Clutch - ON  
Low and Reverse Clutch - OFF

Intermediate Overrun Roller Clutch - LOCKED  
Low and Reverse Roller Clutch - FREE WHEELING  
Intermediate Overrun Band - ON

A manual 3-2 downshift can be accomplished by moving the selector lever from drive to intermediate range (L<sub>2</sub>). Intermediate oil from the manual valve is then directed to:

1. Intermediate Boost Valve
2. 2-3 Shift Valve

Intermediate oil at the pressure regulator intermediate boost valve will increase minimum line pressure to 80 PSI. Intermediate oil will move the 2-3 shift valve to the downshifted position regardless of speed. This in turn releases the direct clutch.

When the manual valve is moved to the intermediate position R.N.D. oil is exhausted. 1-2 clutch oil acting on the intermediate servo piston then applies the intermediate overrun band which places the transmission in second gear. This

provides engine braking in the intermediate range by preventing clockwise rotation of the direct clutch drum, sun gear drive shell, and sun gear once the transmission is in second gear, it cannot upshift to third gear regardless of speed.

### Summary

When the forward, intermediate clutches and intermediate overrun band are applied, the transmission is in intermediate range—second gear and allows engine braking. When vehicle slows down to approximately 9 MPH a 2-1 shift will occur when decreased governor pressure allows the 1-2 shift valve to move and exhaust the 1-2 clutch.

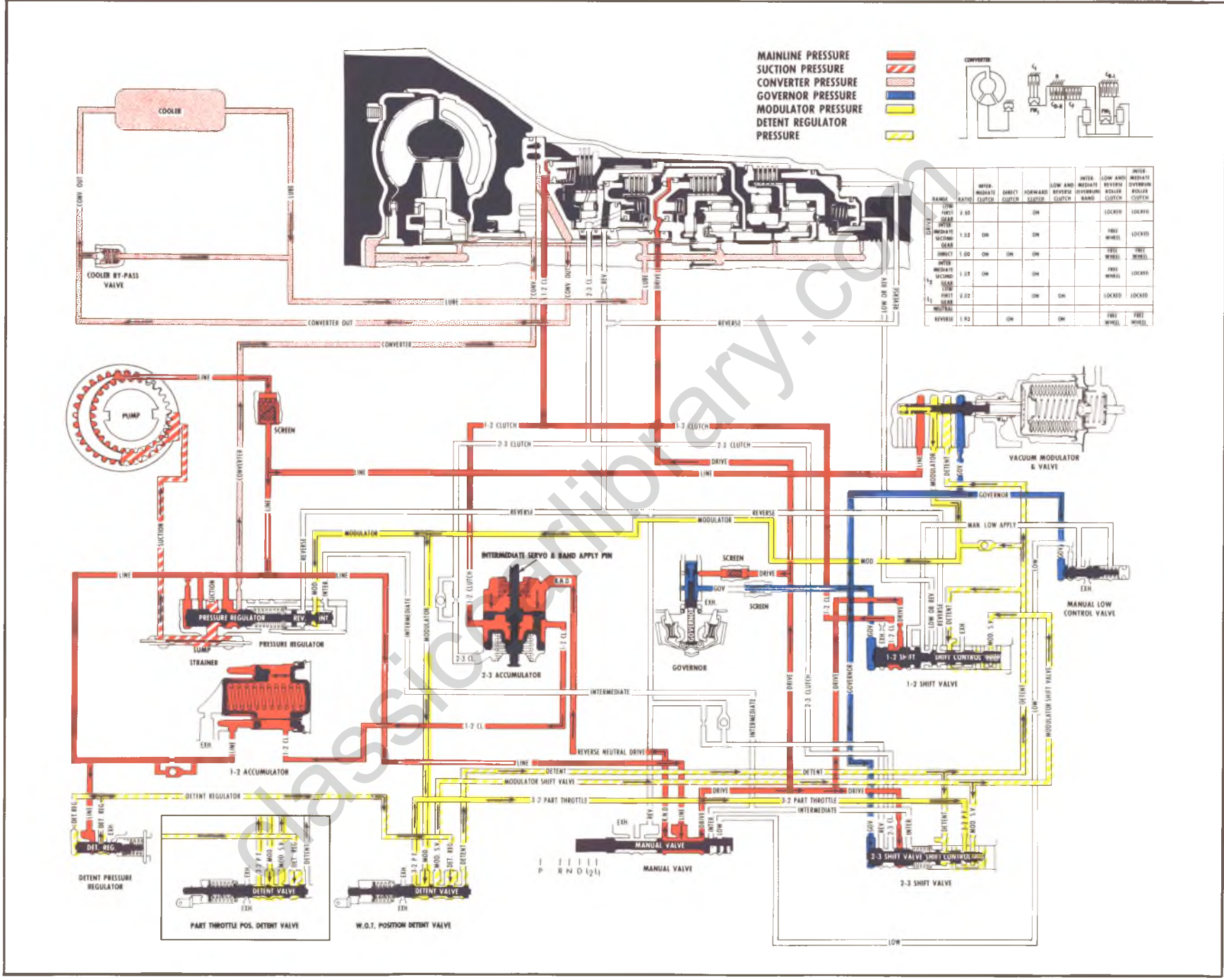

Fig. 24M—Drive Range Detent Downshift (1-2 and 2-3 Shift Valves in Second Gear Position) - Typical

**DRIVE RANGE DETENT DOWNSHIFT (1-2 AND 2-3 SHIFT  
VALVES IN SECOND GEAR POSITION)**

Intermediate Clutch - ON  
Direct Clutch - OFF  
Forward Clutch - ON  
Low and Reverse Clutch - OFF

Intermediate Overrun Roller Clutch - LOCKED  
Low and Roller Clutch - FREE WHEELING  
Intermediate Overrun Band - OFF

While operating at speeds below approximately 75 MPH, a forced or detent 3-2 downshift is possible by depressing the accelerator fully. This moves the detent valve by cable linkage, to its extreme inner position allowing modulator oil to be routed into the 3-2 part throttle passage and detent regulator oil to be routed into the modulator shift valve and detent passages. Detent regulated oil therefore acts on both the 1-2 & 2-3 shift control valves and modulator pressure also acts on the 2-3 shift control valve through the 3-2 part throttle passage. Detent regulator oil is also routed to the modulator valve via the detent passage.

Modulator oil, detent regulator oil plus the force of the 2-3 shift control valve spring will move the 2-3 shift valve to the downshifted position below approximately 75 MPH shifting the transmission to second gear.

A detent 2-1 or 3-1 downshift can also be accomplished below approximately 40 MPH because detent regulator oil is directed to the 1-2 shift control

valve. This allows detent regulator oil plus the force of the 1-2 shift control valve spring to move the 1-2 shift valve to the downshifted position placing the transmission in first gear.

Detent regulator oil is directed to the modulator valve to prevent modulator pressure from falling below that of detent regulator at high speeds or at high altitudes.

**NOTE:** the 3-2 part throttle downshift can be made below 50 MPH (see insert of detent valve in part throttle position). At light throttle opening the 3-2 part throttle passage is exhausted; however, at moderate throttle opening the detent valve connects modulator pressure to the 3-2 part throttle passage. If modulator pressure acting on the 3-2 part throttle area of the 2-3 shift control valve plus the 2-3 shift valve spring is sufficient to move the valve to the downshifted position, the transmission will be in second gear.

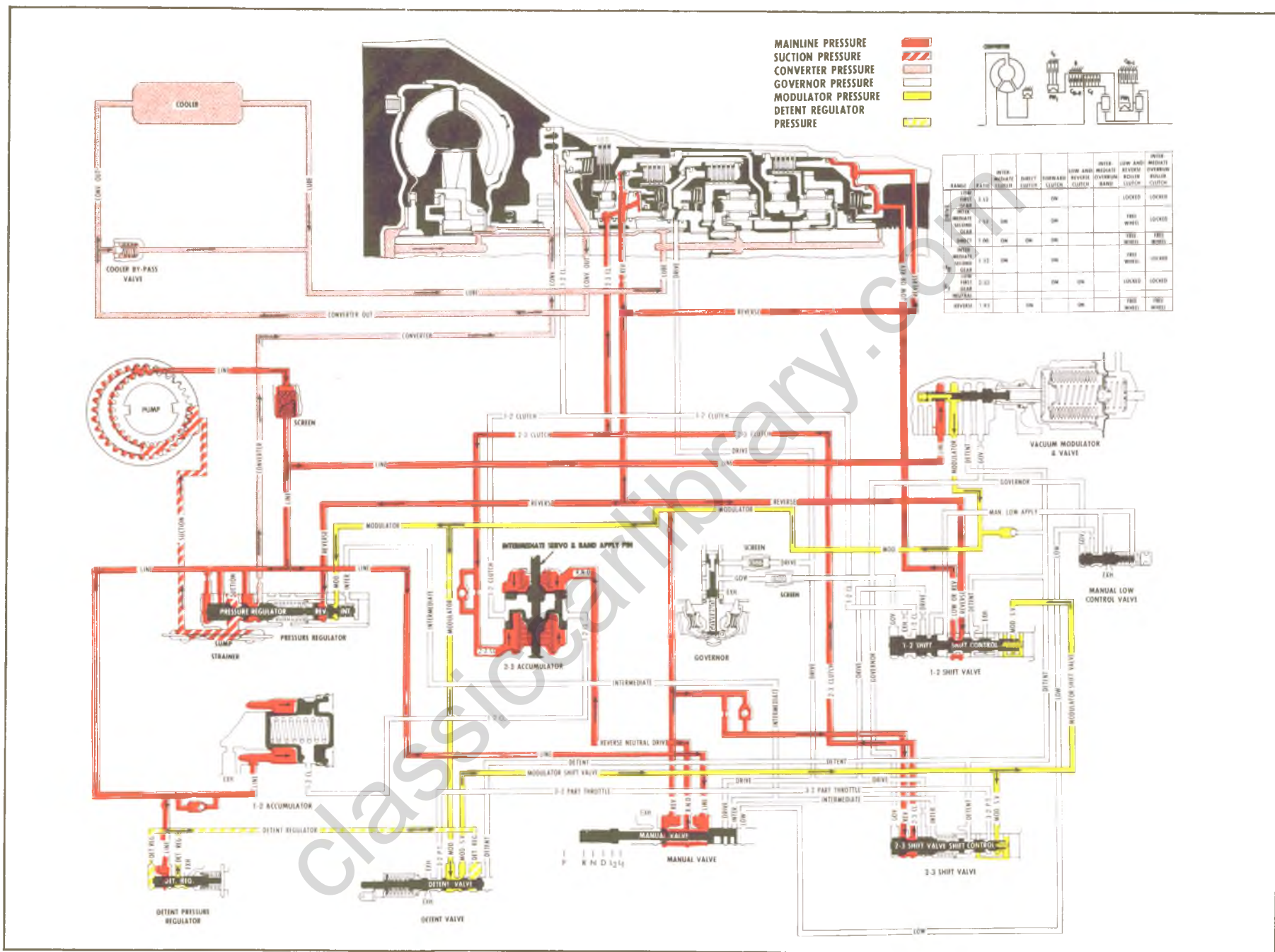

Fig. 25M—Reverse Range - Typical

## REVERSE RANGE

Intermediate Clutch - OFF  
Direct Clutch - ON  
Forward Clutch - OFF  
Low and Reverse Clutch - ON

Intermediate Roller Clutch - INEFFECTIVE  
Low and Reverse Roller Clutch - INEFFECTIVE  
Intermediate Overrun Band - OFF

When the selector lever is moved to the reverse position, the manual valve is repositioned to allow line pressure to enter the reverse circuit. Reverse oil then flows as shown below.

1. Direct (2-3) Clutch.
2. Low and Reverse Clutch
3. 1-2 Shift Valve
4. 2-3 Shift Valve
5. Reverse Boost Valve

### Basic Control

Reverse oil from the manual valve flows to the outer area of the direct clutch

piston, to the outer area of the low and reverse clutch piston, to the 1-2 shift valve and to the 2-3 shift valve. From the 1-2 shift valve, it is directed to the inner area of the low and reverse clutch piston. From the 2-3 shift valve it is directed to the inner area of the direct clutch piston.

Reverse oil also acts on the reverse boost valve to increase line pressure to a maximum of 250 PSI at stall.

### Summary

The direct clutch and the low and reverse clutch are applied. Line pressure is boosted and the transmission is in reverse.

## MAINTENANCE AND ADJUSTMENTS

### TRANSMISSION FLUID

#### Fluid Level and Capacity

The fluid level indicator is located in filler tube at right rear of engine. To bring the fluid level from the ADD mark to the FULL mark requires one pint of fluid. Fluid level should be checked at every engine oil change.

Fluid level should be to the FULL mark with the transmission fluid at normal operating temperature (200° F). With warm fluid (room temperature 70°F), the level will be 1/4 inch below the ADD mark on the dipstick. The normal operating temperature is obtained only after at least 15 miles of highway type driving or the equivalent of city driving.

Approximately 8 pints of fluid are required to refill transmission after oil pan has been drained. The fluid capacity of the Turbo Hydra-matic 350 transmission and converter assembly is approximately 21 1/2 pints but correct level is determined by the mark on the dipstick rather than by amount added. Use only DEXRON® or DEXRON® II automatic transmission fluid or its equivalent.

**NOTE:** An early stage to a darker color from the usual red color and/or a strong odor that is usually associated with overheated transmission fluid is normal, and is not a positive sign of required maintenance or transmission failure.

#### Checking Procedure and Adding Fluid

To determine proper fluid level at normal operating temperature, proceed as follows:

1. Position vehicle on a level surface, place selector lever in park (P), apply parking brake and have engine running at normal idle.
2. Remove fluid level indicator, wipe it clean and reinstall fully until cap seats.
3. Remove indicator and reading of fluid level should be at full "F" mark.
4. If additional fluid is required, add DEXRON® or DEXRON® II automatic transmission fluid or its equivalent to "F" mark on indicator.

If the vehicle cannot be driven sufficiently to bring the transmission to operating temperature and it becomes necessary to check the fluid level, the transmission may be checked at room temperature (70 degrees F) as follows:

1. Position selector lever in park (P), apply parking brake and start engine. **DO NOT RACE ENGINE.** Move selector lever through each range.
2. Immediately check fluid level with selector lever in Park, engine running and vehicle on LEVEL surface.

Fluid level on indicator should be 1/4 inch below the "ADD" mark.

3. If additional fluid is required, add enough fluid to bring level to 1/4" below the ADD mark on the dipstick. If transmission fluid level is correctly established at 70°F, it will appear at the FULL mark on the dipstick when the transmission reaches its normal operating temperature of 200°F.

**CAUTION:** *DO NOT OVERFILL, as foaming and loss of fluid through the vent pipe might occur as fluid heats up.*

If fluid is too low, especially when cold, complete loss of drive may result which can cause transmission failure.

#### Draining and Refilling Transmission

The oil pan should be drained and the strainer cleaned every 24,000 miles and fresh fluid added to obtain the proper level on indicator. For vehicles subjected to heavy city traffic during hot weather, or in commercial use, when the engine is regularly idled for prolonged periods or when vehicle is used for towing the oil pan should be drained and the strainer cleaned every 12,000 miles.

Drain fluid immediately after operation before it has had an opportunity to cool.

**WARNING:** Transmission fluid temperature can exceed 350°F.

1. Raise vehicle and support transmission with suitable jack at the transmission.
2. Remove transmission crossmember support on Nova only.
3. With fluid receptacle placed under transmission oil pan, remove oil pan attaching bolts from front and side of pan.
4. Loosen rear pan attaching bolts approximately four (4) turns.
5. Carefully pry transmission oil pan loose with screwdriver, allowing fluid to drain.
6. Remove remaining screws and remove oil pan and gasket. Discard gasket.
7. Drain fluid from oil pan. Clean pan with solvent and dry thoroughly with clean compressed air.
8. Remove two (2) strainer-to-valve body screws, strainer and gasket. Discard gasket.
9. Thoroughly clean strainer assembly in solvent and dry thoroughly with clean compressed air.
10. Install new strainer-to-valve body gasket, strainer and two (2) screws.
11. Install new gasket on oil pan and install oil pan. Tighten its thirteen (13) attaching bolt and washer assemblies to 12 pound-feet torque.



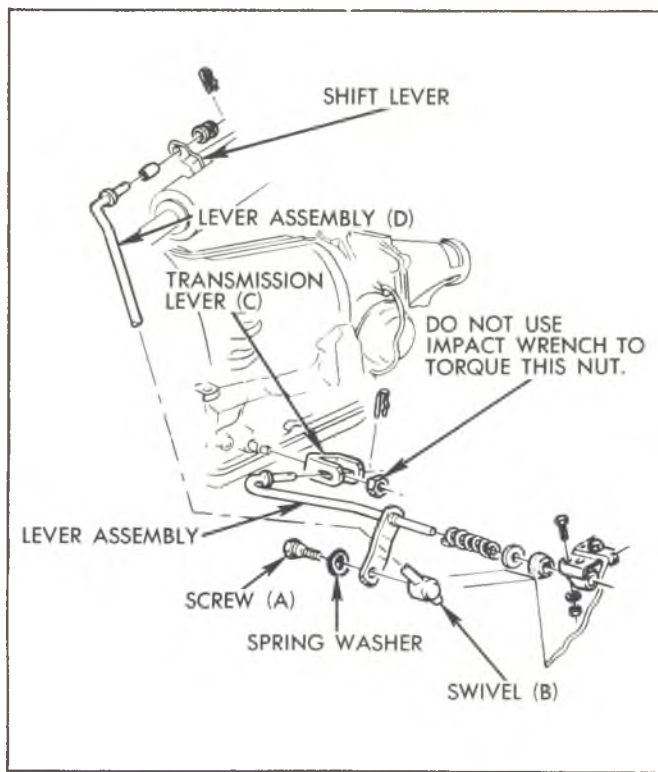

Fig. 26M—Column Shift Linkage - CK Series

12. Lower vehicle add approximately 5 pints U.S. measure (4 pints Imperial measure) of DEXRON® or DEXRON®II automatic transmission fluid or its equivalent through filler tube.
13. With selector lever in PARK position, apply hand brake, start engine and let idle (carburetor off fast idle step). DO NOT RACE ENGINE.
14. Move selector lever through each range and, with selector lever in PARK range, check the fluid level.
15. Add additional fluid to bring level to 1/4" below the ADD mark on the dipstick.

**CAUTION:** Do not overfill. Foaming will result if overfull.

#### Adding Fluid to Fill Dry Transmission and Converter Assembly

In cases of transmission overhaul, when a complete fill is required, including converter (approximately 20 pints), proceed as follows:

1. Add 8 pints of transmission fluid through filler tube.
2. With manual control lever in park (P) position, start engine and place on cold idle cam. DO NOT RACE ENGINE. Move manual control lever through each range.
3. Immediately check fluid level with selector lever in park (P), engine running and vehicle on LEVEL surface and add additional fluid to bring level to 1/4" below the "ADD" mark on the dipstick. Do not overfill.

## CHECKING TRANSMISSION MOUNT

Raise vehicle on a hoist. Push up and pull down on transmission tailshaft while observing transmission mount. If rubber separates from metal plate of mount or if tailshaft moves up but not down (mount bottomed out) replace mount. If there is relative movement between a metal plate of mount and its attaching point, tighten screws or nuts attaching mount to transmission or crossmember.

## SHIFT CONTROLS

### Column Shift Linkage - CK and P Series (Figs. 26M and 27M)

1. The shift tube and lever assembly must be free in the mast jacket. See Section 9 for alignment of steering column assembly if necessary.
2. To check for proper shift linkage adjustment, lift the transmission selector lever towards the steering wheel. Allow the selector lever to be positioned in drive (D) by the transmission detent.

**NOTE:** Do not use the indicator pointer as a reference to position the selector lever. When performing linkage adjustment, pointer is adjusted last.

3. Release the selector lever. The lever should be inhibited from engaging low range unless the lever is lifted.
4. Lift the selector lever towards the steering wheel, and allow the lever to be positioned in neutral (N) by the transmission detent.
5. Release the selector lever. The lever should now be inhibited from engaging reverse range unless the lever is lifted.
6. A properly adjusted linkage will prevent the selector lever from moving beyond both the neutral detent, and the drive detent unless the lever is lifted to pass over the mechanical stop in the steering column.
7. If adjustment is required, remove screw (A) and spring washer from swivel (B).
8. Set transmission lever (C) in Neutral position by moving lever counterclockwise to L1 detent and then clockwise three (3) detent positions to Neutral.
9. Position transmission selector lever in Neutral position as determined by the mechanical stop in steering column assembly.

**NOTE:** Do not use the indicator pointer as a reference to position the selector lever. When performing linkage adjustment, pointer is adjusted last.

10. Assemble swivel, spring washer and screw to lever assembly (D) and tighten screw to 20 pound feet.
11. Readjust indicator needle if necessary to agree with the transmission detent positions. See Section 9.
12. Readjust neutral start switch if necessary to provide

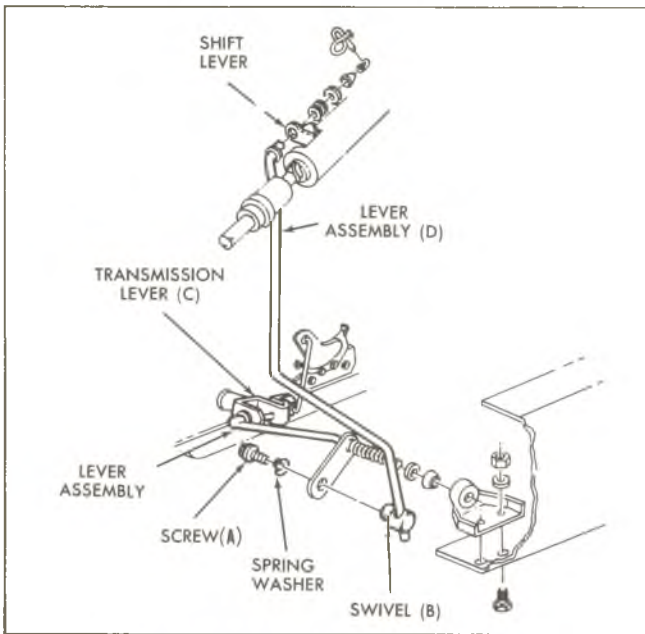

Fig. 27M—Column Shift Linkage - P Series

the correct relationship to the transmission detent positions. See Section 12.

13. Check operation (CK Series):

- a. With key in "Run" position and transmission in "Reverse" be sure that key cannot be removed and that steering wheel is not locked.
- b. With key in "Lock" position and shift lever in "Park", be sure that key can be removed, that steering wheel is locked, and that transmission remains in "Park" when steering column is locked.

**CAUTION:** Any inaccuracies in the above adjustments may result in premature failure of the transmission due to operation without controls in full detent. Such operation results in reduced oil pressure and in turn partial engagement of the affected clutches. Partial engagement of the clutches with sufficient pressure to cause apparent normal operation of the vehicle will result in failure of the clutches or other internal parts after only a few miles of operation.

**Column Shift Linkage - G Series (Fig. 28M)**

1. The shift tube and lever assembly must be free in the mast jacket. See Section 9 for alignment of steering column assembly if necessary.
2. To check for proper shift linkage adjustment, lift the transmission selector lever towards the steering wheel. Allow the selector lever to be positioned in drive (D) by the transmission detent.

**NOTE:** Do not use the indicator pointer as a reference to position the selector lever. When performing linkage adjustment, pointer is adjusted last.

3. Release the selector lever. The lever should be inhibited from engaging low range unless the lever is lifted.
  4. Lift the selector lever towards the steering wheel, and allow the lever to be positioned in neutral (N) by the transmission detent.
  5. Release the selector lever. The lever should now be inhibited from engaging reverse range unless the lever is lifted.
  6. A properly adjusted linkage will prevent the selector lever from moving beyond both the neutral detent and the drive detent unless the lever is lifted to pass over the mechanical stop in the steering column.
  7. If adjustment is required, loosen nut (A) on steering column to allow swivel (B) and clamp (C) to move freely on rod (D).
  8. Set transmission lever (E) in Neutral position by moving lever counter-clockwise to L1 detent and then clockwise three (3) detent positions to Neutral.
  9. Position transmission selector lever in Neutral position as determined by the mechanical stop in steering column assembly.
- NOTE:** Do not use the indicator pointer as a reference to position the selector lever. When performing linkage adjustment, pointer is adjusted last.
10. Tighten nut (A) 18 pound-feet.
  11. Readjust indicator needle if necessary to agree with the transmission detent positions. See Section 9.
  12. Readjust neutral start switch if necessary to provide the correct relationship to the transmission detent positions. See Section 12.

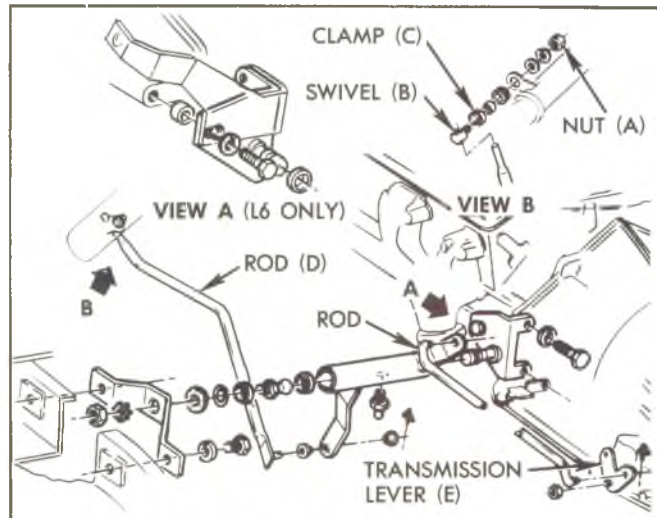

Fig. 28M—Column Shift Linkage - G Series

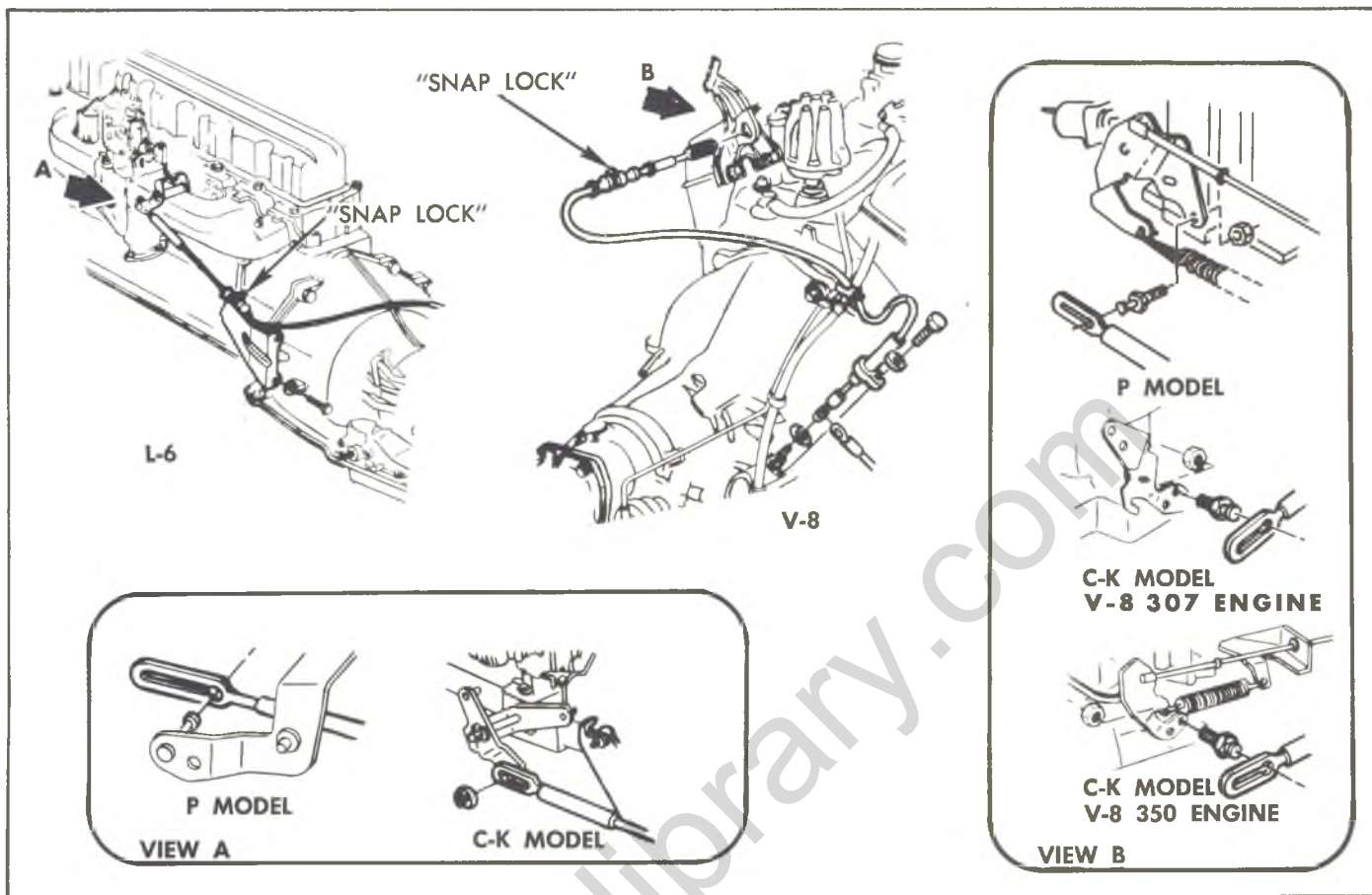

Fig. 29M—Detent Downshift Cable - C, K and P Series

**CAUTION:** Any inaccuracies in the above adjustments may result in premature failure of the transmission due to operation without controls in full detent. Such operation results in reduced oil pressure and in turn partial engagement of the affected clutches. Partial engagement of the clutches with sufficient pressure to cause apparent normal operation of the vehicle will result in failure of the clutches or other internal parts after only a few miles of operation.

### DETENT DOWNSHIFT CABLE (FIGS. 29M and 30M)

#### Remove

1. Push up on bottom of snap-lock and release lock and detent downshift cable.
2. Compress locking tabs and disconnect snap-lock assembly from bracket.
3. Disconnect cable from carburetor lever.
4. Remove clamp around filler tube, remove screw and washer securing cable to transmission and disconnect detent downshift cable.

#### Install

1. Install new seal on detent downshift cable lubricant seal with transmission fluid.
2. Connect transmission end of detent downshift cable and secure to transmission case with bolt and washer tightened to 75 pound inches.
3. Route cable in front of filler tube and install clamp around filler tube, modulator pipe and detent downshift cable. Locate clamp approximately 2 inches above filler tube bracket.
4. Pass cable through bracket and engage locking tabs of snap-lock on bracket.
5. Connect cable to carburetor lever.

#### Adjust

With snap-lock disengaged, position carburetor to wide open throttle (W.O.T.) position and push snap-lock downward until top is flush with rest of cable.

### NEUTRAL START SWITCH

The adjustment of the neutral start switch is described in Section 12, Electrical.

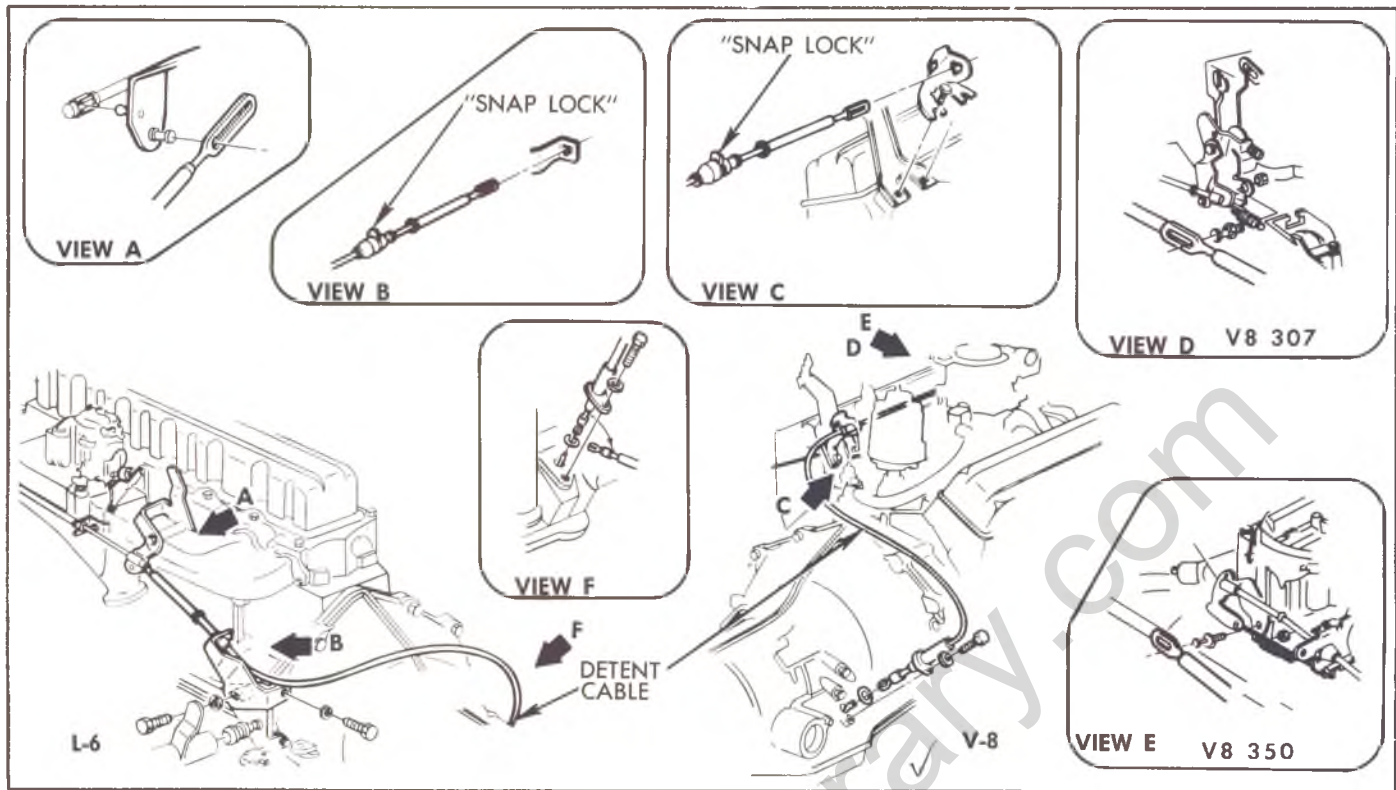

Fig. 30M—Detent Downshift Cable - G Series

## SERVICE OPERATIONS

### VACUUM MODULATOR AND MODULATOR VALVE ASSEMBLY

#### Removal

1. Disconnect vacuum hose from vacuum modulator stem and remove vacuum modulator attaching screw and retainer.
2. Remove modulator assembly and its O-ring seal from case.
3. Remove modulator valve from case.

#### Installation

Installation of the modulator and modulator valve is the reverse of REMOVAL. Install a new O-ring seal and adjust the fluid level.

### OIL COOLER PIPES

If replacement of transmission steel tubing cooler pipes is required, use only double wrapped and brazed steel tubing meeting GM specification 123M or its equivalent. Under no condition use copper or aluminum tubing to replace steel tubing. Those materials do not have satisfactory fatigue durability to withstand normal vehicle vibrations.

Steel tubing should be flared using the upset (double lap) flare method which is detailed in Section 5.

### GOVERNOR

#### Remove

1. Raise vehicle and disconnect speedometer cable at transmission.
2. Remove governor cover retainer and governor cover.  
**NOTE:** Be careful not to damage cover and "O" ring seal.
3. Remove governor. Inspect weights and valve for freeness.

#### Install

1. Install governor.
2. Install governor cover using a brass drift around the outside flange of the cover.  
**NOTE:** Do not distort cover on installation. Be sure "O" ring seal is not cut or damaged.
3. Install retainer.
4. Connect speedometer cable, lower vehicle and check transmission fluid level.

**SPEEDOMETER DRIVEN GEAR****Removal**

1. Disconnect speedometer cable.
2. Remove retainer bolt, retainer, speedometer driven gear and O-ring seal.

**Installation**

Installation of speedometer driven gear is the reverse of REMOVAL. Install new O-ring seal (if required) and adjust the fluid level.

**SPEEDOMETER DRIVE GEAR****Removal**

1. Raise vehicle and support transmission with suitable transmission jack.
2. Remove propeller shaft.
3. Disconnect speedometer cable.
4. Disconnect transmission rear mount from frame crossmember.
5. Remove two bolts at each end of frame cross member and remove crossmember.
6. Remove extension housing.
7. Install Special Tools J-21427-01 and J-8105 on output shaft and remove speedometer drive gear. Remove retaining clip.

**Installation**

1. Place speedometer drive gear retaining clip into hole in output shaft.
2. Align slot in speedometer drive gear with retaining clip and install.
3. Install extension housing and tighten attaching bolts to 25 pound feet.
4. Connect speedometer cable.
5. Install crossmember to frame and transmission.
6. Install propeller shaft.
7. Remove transmission jack and lower vehicle.

**EXTENSION HOUSING OIL SEAL****Removal**

1. Remove propeller shaft.
2. Pry out lip oil seal with screwdriver or small chisel.

**Installation**

1. Coat outer casing of new lip oil seal with a non-hardening sealer and drive it into place with Installer J-21426.
2. Install propeller shaft and adjust fluid level.

**1-2 ACCUMULATOR****Remove**

1. Remove two transmission oil pan bolts below the

1-2 accumulator cover. Install J-23069 in place of bolts removed.

2. Press in on cover and remove retaining ring.
3. Remove cover "O" ring seal, spring and 1-2 accumulator.

**Install**

1. Install 1-2 accumulator piston.

NOTE: Rotating piston slightly when installing will help to get rings started in bore.

2. Position spring, "O" ring seal and cover in place.
3. Press in on cover with J-23069 and install retaining ring.
4. Remove tool and install oil pan bolts.

**VALVE BODY ASSEMBLY****Removal**

1. Referring to draining procedures, drain transmission fluid from oil pan.
2. After oil pan and strainer, have been removed, discard gaskets.
3. Remove detent spring and roller assembly from valve body and remove valve body-to-case bolts.
4. Remove valve body assembly while disconnecting manual control valve link from range selector inner lever and removing detent control valve link from the detent actuating lever.
5. Remove manual valve and link assembly from valve body assembly.

**Installation**

Installation of the valve body assembly is the reverse of REMOVAL. Install new gaskets to strainer and oil pan and adjust the fluid level.

**MANUAL SHAFT, RANGE SELECTOR INNER LEVER AND PARKING LINKAGE ASSEMBLIES****Removal**

1. Referring to draining procedures, drain transmission fluid from oil pan.
2. After oil pan and strainer have been removed, remove valve body assembly. Discard gaskets.
3. Remove manual shaft-to-case retainer and unthread jam nut holding range selector inner lever to manual shaft.
4. Remove jam nut and remove manual shaft from range selector inner lever and case.

NOTE: Do not remove manual shaft lip oil seal unless replacement is required.

5. Remove parking pawl actuating rod and range selector inner lever from case.
6. Remove bolts and parking lock bracket.

- Remove parking pawl disengaging spring and, if necessary to replace park pawl or shaft, clean up bore in case and remove parking pawl shaft retaining plug, park pawl shaft and pawl.

#### Installation

Installation of parking linkage, selector lever and manual shaft is the reverse of REMOVAL. Install new plug (if required), new lip oil seal (if required) and new gaskets. Adjust the fluid level.

### TRANSMISSION REPLACEMENT

#### (All Except K Model)

- Before raising the vehicle, disconnect the negative battery cable detent downshift cable at carburetor and release the parking brake.
- Raise vehicle on hoist.
- Remove propeller shaft.
- Disconnect speedometer cable, detent downshift cable, modulator vacuum line and oil cooler pipes at transmission.
- Disconnect shift control linkage.
- Support transmission with suitable transmission jack.
- Disconnect rear mount from frame crossmember.
- Remove two bolts at each end of frame crossmember. Remove crossmember.
- Remove converter under pan.
- Remove converter to flywheel bolts.
- Lower transmission until jack is barely supporting it.
- Remove transmission to engine mounting bolts and remove oil filler tube at transmission.
- Raise transmission to its normal position, support engine with jack and slide transmission rearward from engine and lower it away from vehicle.

**CAUTION:** Use suitable converter holding tool when lowering transmission or keep rear of transmission lower than front so as not to lose converter.

The installation of the transmission is the reverse of the removal with the following added step. Before installing the flex plate to converter bolts, make certain that the attaching lugs on the converter are flush with the flex plate and the converter rotates freely by hand in this position. Then, hand start all three bolts and tighten finger tight before torquing to specification. This will insure proper converter alignment.

After installation of transmission, lower vehicle and remove vehicle from hoist. Check linkage for proper adjustment.

Check transmission fluid level.

### TRANSMISSION REPLACEMENT

#### (K Model)

#### Removal

- Disconnect battery cable.
- Remove transmission dipstick.
- Disconnect detent downshift cable at carburetor.
- Remove transfer case shift lever knob and boot.
- Raise vehicle on hoist.
- Remove flywheel cover.
- Remove torque converter to flywheel attaching bolts. (Secure the converter.)
- Disconnect transmission shift linkage and speedometer cable.
- Remove engine crossunder pipe to manifold bolts.
- Disconnect vacuum modulator line, line to filler tube clip and detent downshift cable to filler tube strap.
- Disconnect detent downshift cable at the transmission.
- Disconnect transmission oil cooler lines at the transmission.
- Remove transfer case adapter to crossmember bolts.
- Raise engine as necessary.
- Remove crossmember bolts and remove crossmember.
- Remove exhaust system hanger bolts.
- Disconnect rear propeller shaft at transfer case.
- Disconnect parking brake cable.
- Disconnect exhaust system. (Tie aside.)
- Disconnect front propeller shaft at front axle. (Tie aside.)
- Support transmission and transfer case with jack (use safety chains).
- Remove transfer case to frame bracket bolts.
- Remove transmission to engine bolts, remove transmission and transfer case.
- Remove transfer case from transmission (includes: new "O" ring seal).
- Move transmission to bench fixture.
- Drain transmission.
- Remove torque converter.
- Remove and discard front pump seal.
- Refill transfer case.

#### Installation

Reverse removal procedure to install.

## DIAGNOSIS

### SEQUENCE FOR DIAGNOSIS

1. Check and correct fluid level.
2. Check detent cable adjustment.
3. Check and correct vacuum line and fittings.
4. Check and correct manual linkage.
5. Road test vehicle.
  - a. Install oil pressure gauge.
  - b. Road test using all selective ranges, noting when discrepancies in operation or oil pressure occur.
  - c. Attempt to isolate the unit or circuit involved in the malfunction.
  - d. If engine performances indicates an engine tune-up is required, this should be performed before road testing is completed or transmission correction attempted. Poor engine performance can result in rough shifting or other malfunctions.

### FLUID CHECKING PROCEDURES

Refer to Maintenance and Adjustment Section for fluid checking procedures.

### FLUID LEAK DIAGNOSIS

#### Determining Source of Oil Leak

Before attempting to correct an oil leak, the actual source of the leak must be determined. In many cases, the source of the leak can be deceiving due to "wind flow" around the engine and transmission.

The suspected area should be wiped clean of all oil before inspecting for the source of the leak.

The use of a "Black Light" to locate the point at which the oil is leaking is helpful. Comparing the oil from the leak to that on the engine or transmission dipstick, when viewed by black light, will determine the source of the leak - engine or transmission.

Oil leaks around the engine and transmission are generally carried toward the rear of the vehicle by air

stream. For example, a transmission oil filler tube to case leak will sometimes appear as a leak at the rear of the transmission. In determining the source of a leak, proceed as follows:

1. Degrease underside of transmission.
2. Road test to get unit at operating temperature.
3. Inspect for leak with engine running.
4. With engine off, check for oil leaks due to the raised oil level caused by drain back.

#### Possible Points of Oil Leak

1. Transmission Oil Pan Leak.
  - a. Attaching bolts not correctly torqued.
  - b. Improperly installed or damaged pan gasket.
  - c. Oil pan gasket mounting face not flat.
2. Extension Housing.
  - a. Attaching bolts not correctly torqued.
  - b. Rear seal assembly damaged or improperly installed.
  - c. Square seal, extension to case, damaged or improperly installed.
  - d. Porous casting. See subparagraph C.
3. Case Leak.
  - a. Filler pipe "O" ring seal damaged or missing; misposition of filler pipe bracket to engine.
  - b. Modulator assembly "O" ring seal damaged or improperly installed.
  - c. Detent cable connector "O" ring seal damaged or improperly installed.
  - d. Governor cover not tight, gasket damaged or leak between case face and gasket.
  - e. Speedometer gear "O" ring damaged.
  - f. Manual shaft seal damaged or improperly installed.
  - g. Line pressure tap plug loose.

## 7A-36 AUTOMATIC TRANSMISSION

- h. Vent pipe (refer to item 5).
  - i. Porous casting. See Subparagraph C.
4. Leak at Front of Transmission.
- a. Front pump seal leaks.
    - 1. Seal lip cut. Check converter hub, etc.
    - 2. Bushing moved and damaged, Oil return hole plugged.
    - 3. No oil return hole.
  - b. Front pump attaching bolts loose or bolt washer type seals damaged or missing.
  - c. Front pump housing "O" ring damaged or cut.
  - d. Converter leak in weld area.
  - e. Porous casting (pump).
5. Oil Comes Out Vent Pipe.
- a. Transmission over-filled.
  - b. Water in oil.
  - c. Foreign material between pump and case or between pump cover and body.
  - d. Case - porous near converter bosses. Front pump cover or housing oil channels shy or stock near breather. See Subparagraph C.
  - e. Pump to case gasket mis-positioned.

### OIL PRESSURE CHECK

While vehicle is stationary (service brake on), engine speed set to 1200 rpm, transmission oil pressure gauge attached, and vacuum modulator tube disconnected, the transmission line should check as shown in Figure 31M.

While vehicle is stationary (service brake on), engine speed set to maintain 12 inches hg absolute manifold pressure, transmission oil pressure gauge attached, and vacuum modulator tube connected, the transmission line should check as shown in Figure 32M.

### CASE POROSITY REPAIR

External oil leaks caused by case porosity can be

Approximate Altitude of Check (Ft. Above Sea Level)	250 L-6			307 V-8 & 350 V-8		
	Drive Neutral Park	L1 or L2	Reverse	Drive Neutral Park	L1 or L2	Reverse
0	173	166	262	167	166	254
2000	163	159	248	158	159	240
4000	154	152	254	149	152	226
6000	146	146	221	141	146	213
8000	138	141	210	133	140	202

Fig. 31M—Oil Pressure Check

Approximate Altitude of Check (Ft. Above Sea Level)	Relative Engine Vacuum (" Hg.)	250 L-6			307 V-8 & 350 V-8		
		Drive Neutral Park	L1 or L2	Reverse	Drive Neutral Park	L1 or L2	Reverse
0	13.92	55	79	84	85	105	129
2000	11.83	63	85	96	88	108	134
4000	9.86	72	91	109	91	110	138
6000	7.96	79	97	120	94	112	142
8000	6.23	86	102	131	96	113	146

Fig. 32M—Oil Pressure Check

successfully repaired with the transmission in the vehicle by using the following recommended procedures:

1. Road test and bring the transmission to operating temperature, approximately 180 degrees F.
2. Raise vehicle on a hoist or jack stand, engine running, and locate source of oil leak. Check for oil leaks in Low, Drive, and Reverse.
3. Shut engine off and thoroughly clean area to be repaired with a suitable cleaning solvent and a brush - air dry.
 

A clean, dry soldering acid brush can be used to clean the area and also to apply the epoxy cement.
4. Using instructions of the manufacturer, mix a sufficient amount of epoxy to make the repair. Make certain the area to be repaired is fully covered.
5. Allow cement to cure for 3 hours before starting engine.
6. Road test and check for leaks.

### VACUUM MODULATOR DIAGNOSIS

A defective vacuum modulator can cause one or more of the following complaints.

1. Harsh upshifts and downshifts.
2. Delayed upshifts.
3. Soft upshifts and downshifts.
4. Slips in low, drive and reverse.
5. Transmission overheating.
6. Engine burning transmission oil.

If any one of the above complaints are encountered, the modulator must be checked.

### Vacuum Diaphragm Leak Check

Insert a pipe cleaner into the vacuum connector pipe as far as possible and check for the presence of transmission oil. If oil is found, replace the modulator.

Gasoline or water vapor may settle in the vacuum side of the modulator. If this is found without the presence of



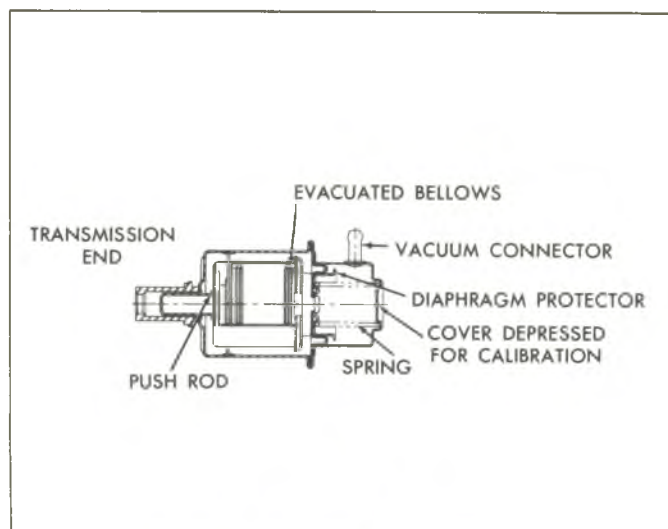

Fig. 33M—Vacuum Modulator Assembly

oil, the modulator is serviceable and should not be changed.

### Atmospheric Leak Check

Apply a liberal coating of soap bubble solution to the vacuum connector pipe seam, the crimped upper to lower housing seam (Fig. 33M). Using a short piece of rubber tubing, apply air pressure to the vacuum pipe by blowing into the tube and observe for leak bubbles. If bubbles appear, replace the modulator.

NOTE: Do not use any method other than human lung power for applying air pressure, as pressures over 6 psi may damage the modulator.

### Bellows Comparison Check

Using a comparison gauge, as shown in Fig. 34M, compare the load of a known good Turbo Hydra-Matic 350 modulator with the assembly in question.

- Install the modulator that is known to be acceptable on either end of the gauge.
- Install the modulator in question on the opposite end of the gauge.
- Holding the modulators in a horizontal position, bring them together under pressure until either modulator sleeve end just touches the line in the center of the gauge. The gap between the opposite modulator sleeve end and the gauge line should then be  $1/16''$  or less. If the distance is greater than this amount, the modulator in question should be replaced. (Figs. 35M, 36M, and 37M).

### Sleeve Alignment Check

Roll the main body of the modulator on a flat surface and observe the sleeve for concentricity to the cam. If the sleeve is concentric and the plunger is free, the modulator is acceptable.

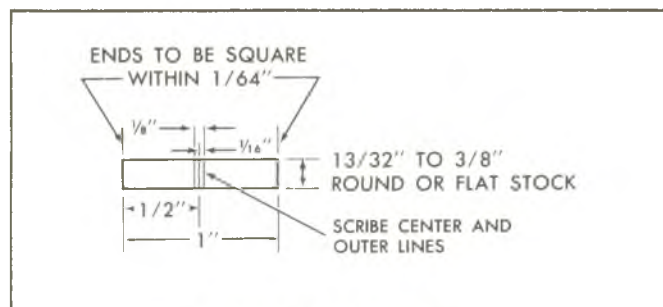

Fig. 34M—Comparison Gauge

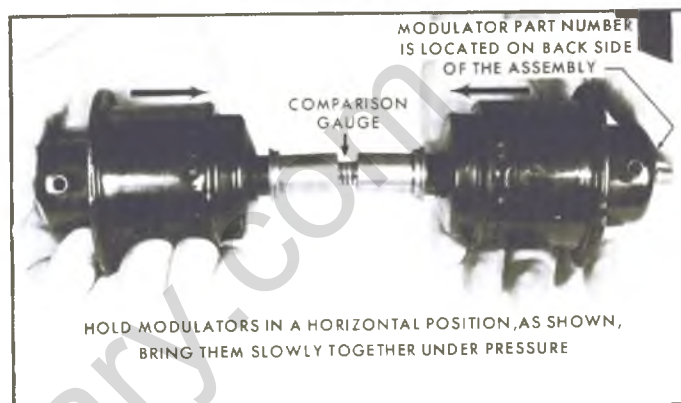

Fig. 35M—Checking Bellows Load

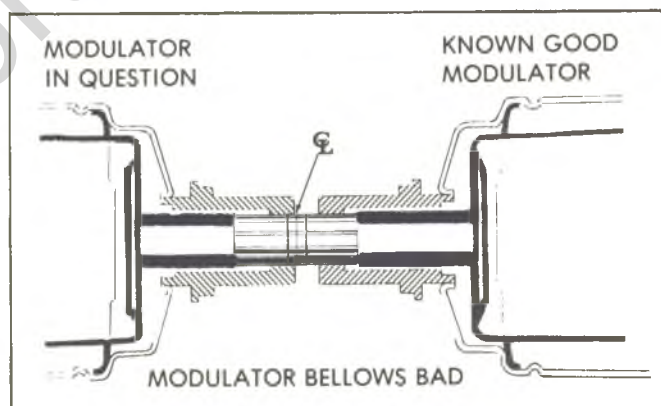

Fig. 36M—Defective Modulator Bellows

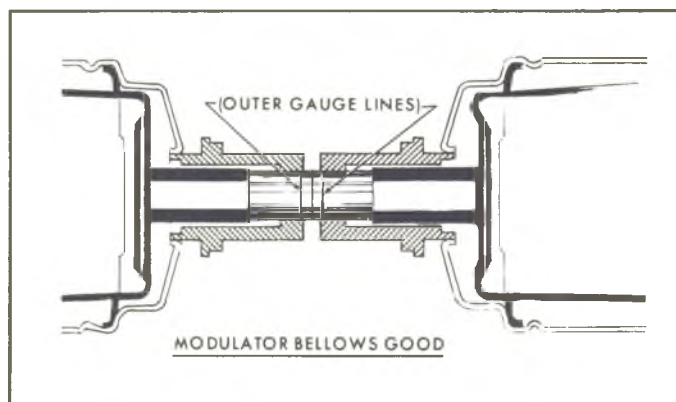

Fig. 37M—Modulator Bellows Good

## 7A-38 AUTOMATIC TRANSMISSION

Once the modulator assembly passes all of the above tests, it is an acceptable part and should be re-used.

### TRANSMISSION CLUTCH PLATES DIAGNOSIS

1. Lined Drive Plates.
  - a. Dry plates with compressed air and inspect the lined surface for:
    1. pitting and flaking
    2. wear
    3. glazing
    4. cracking
    5. charring
    6. chips or metal particles imbedded in lining.

If a lined drive plate exhibits any of the above conditions, replacement is required. Do not diagnose drive plates by color.

2. Steel Driven Plates

Wipe plates dry and check for heat discoloration. If the surface is smooth and an even color smear is indicated, the plate should be reused. If severe heat spot discoloration or surface scuffing is indicated, the plate must be replaced.

3. Clutch Release Springs

Evidence of extreme heat or burning in the area of the clutch may have caused the springs to take a heat set and would justify replacement of the springs.

### CAUSES OF BURNED CLUTCH PLATES

1. FORWARD CLUTCH

- a. Check ball in clutch housing damaged, stuck or missing.
- b. Clutch piston cracked, seals damaged or missing.
- c. Low line pressure.
- d. Pump cover oil seal rings missing, broken or undersize; ring groove oversize.
- e. Case valve body face not flat or porosity between channels.

2. INTERMEDIATE CLUTCH

- a. Intermediate clutch piston seals damaged or missing.
- b. Low line pressure.
- c. Case valve body face not flat or porosity between channels.

3. DIRECT CLUTCH

- a. Restricted orifice in vacuum line to modulator (poor vacuum response).

- b. Check ball in direct clutch piston damaged, stuck or missing.
- c. Defective modulator bellows.
- d. Clutch piston seals damaged or missing.
- e. Case valve body face not flat or porosity between channels.
- f. Clutch installed backwards.

NOTE: Burned clutch plates can be caused by incorrect usage of clutch plates. Also, anti-freeze in transmission fluid can cause severe damage, such as large pieces of composition clutch plate material peeling off.

### GOVERNOR PRESSURE CHECK

1. Install line Pressure Gage.
2. Disconnect vacuum line to modulator.
3. With vehicle on hoist (rear wheels, off ground), foot off brake, in drive, check line pressure at 1000 RPM.
4. Slowly increase engine RPM to 3000 RPM and determine if a line pressure drop occurs (7 PSI or more).
5. If not pressure drop occurs:
  - a. Inspect Governor
    1. Stuck valve.
    2. Free Weights.
    3. Restricted orifice in governor valve.
  - b. Governor Feed System
    1. Check screen in control valve assembly.
    2. Check for restrictions in feed line.
    3. Scored governor bore.

### MANUAL LINKAGE

Manual linkage adjustment and the associated neutral safety switch are important from a safety standpoint. The neutral safety switch should be adjusted so that the engine will start in the Park and Neutral positions only.

With the selector lever in the Park position, the parking pawl should freely engage and prevent the vehicle from rolling. The pointer on the indicator quadrant should line up properly with the range indicators in all ranges.

### ROAD TEST

#### Drive Range

Position selector lever in DRIVE RANGE and accelerate the vehicle from 0 MPH. A 1-2 and 2-3 shift should occur at all throttle openings. (The shift points will vary with the throttle opening). As the vehicle decreases in speed to 0 MPH, the 3-2 and 2-1 shifts should occur.

#### Low L2 Range

Position the selector lever in L2 RANGE and accelerate

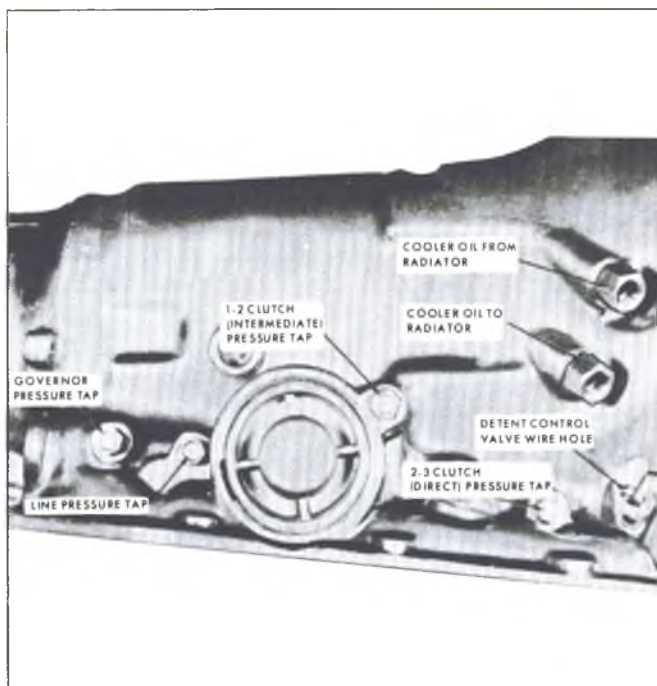

Fig. 38M—Pressure Tap Locations

the vehicle from 0 MPH. A 1-2 shift should occur at all throttle openings. (No. 2-3 shift can be obtained in this range). The 1-2 shift point will vary with throttle opening. As the vehicle decreases in speed to 0 MPH, a 2-1 shift should occur.

The 1-2 shift in INTERMEDIATE RANGE is somewhat firmer than in DRIVE RANGE. This is normal.

### Low L1 Range

Position the selector lever in L1 RANGE and accelerate the vehicle from 0 MPH. No upshift should occur in this range.

### 2ND Gear — Overrun Braking: (L2)

Position the selector lever in DRIVE RANGE, and with the vehicle speed at approximately 35 MPH, move the selector lever to L2 RANGE. The transmission should downshift to 2nd. An increase in engine RPM and an engine braking effect should be noticed. Line pressure should change from approximately 100 PSI to approximately 125 PSI in 2nd.

### 1ST Gear — Overrun Braking: (L1)

Position the selector lever in L2 RANGE at approximately 30 to 50 MPH, with throttle closed, move the selector lever to L1. A 2-1 downshift should occur in the speed range of approximately 45 to 30 MPH, depending on axle ratio and valve body calibration. The 2-1 downshift at closed throttle will be accompanied by increased engine RPM and an engine braking effect should be noticed. Line pressure should be approximately 150 PSI. Stop vehicle.

### Reverse Range: (R)

Position the selector lever in REVERSE POSITION and check for reverse operation.

### TROUBLE DIAGNOSIS

Refer to Diagnosis Chart to determine a possible cause of a transmission problem.

Additional diagnosis of a malfunction is as follows:

### No Drive in Drive Range

(Install pressure gauge)

- Low Oil Level - correct level and check for external leaks or defective vacuum modulator (leaking diaphragm will evacuate oil from unit).
- Manual Linkage - misadjusted, correct alignment to manual lever shift quadrant is essential.
- Low Oil Pressure - refer to LOW LINE PRESSURE below.
- Forward Clutch:
  - a. Forward clutch does not apply - piston cracked; seals missing or damaged; clutch plates burned (see BURNED CLUTCH PLATES below).
  - b. Pump feed circuit-to-forward clutch oil seal rings missing or broken on pump cover; leak in feed circuits; pump-to-case gasket mispositioned or damaged; clutch drum ball check stuck or missing.
- Low and Reverse Roller Clutch Assembly - broken spring, damaged cage or installed backwards.

### High or Low Oil Pressure

(Refer to OIL PRESSURE CHECKS)

### High Line Pressure

- Vacuum Leak:
  - a. Vacuum line disconnected.
  - b. Leak in line from engine to modulator.
  - c. Improper engine vacuum.
  - d. Leak in vacuum-operated accessory (hoses, vacuum advance, etc.).
- Modulator:
  - a. Stuck modulator valve.
  - b. Water in modulator.
  - c. Damaged, not operating properly.
- Detent System - detent valve or cable stuck in detent position.
- Valve Body:
  - a. Pressure regulator and/or boost valve stuck.
  - b. Boost valve sleeve broken or defective.
  - c. Incorrect pressure regulator valve spring.



### Low Line Pressure

- Low transmission oil level.
- Defective vacuum modulator assembly.
- Strainer Assembly:
  - a. Blocked or restricted.
  - b. Gasket omitted or damaged.
- Oil Pump:
  - a. Gear clearance, damaged, worn, gear installed backwards:
  - b. Pump-to-case gasket mispositioned.
  - c. Defective pump body and/or cover.
- Valve Body:
  - a. Pressure regulator or boost valve stuck.
  - b. Pressure regulator valve spring, too weak.
- Internal Circuit Leaks:
  - a. Forward clutch leak (pressure low in Drive range, pressure normal in Neutral and Reverse).
    1. Check pump oil seal rings.
    2. Check forward clutch seals.
  - b. Direct clutch leak (pressure low in Reverse, pressure normal in other ranges).
    1. Check direct clutch outer seal.
    2. Check 1-2 accumulator and 2-3 accumulator pistons and rings for damage or missing.
- Case Assembly - check ball missing from cored passage in case face.

### 1-2 Shift - Full Throttle Only

- Detent Valve - sticking or linkage misadjusted.
- Vacuum Leak - vacuum line or fittings leaking.
- Control Valve Assembly:
  - a. Valve body gaskets - leaking, damaged or incorrectly installed.
  - b. Detent valve train stuck.
  - c. 1-2 valve stuck closed (in downshifted position).
- Case Assembly - refer to case porosity repair.

### First Speed Only - No 1-2 Shift

- Detent (downshift) cable - binding.
- Governor Assembly:
  - a. Governor valve sticking.
  - b. Driven gear loose, damaged or worn (check for pin in case and length of pin showing; also, check output shaft drive gear for nicks or rough finish if driven gear shows damage).
- Control Valve Assembly:
  - a. Valve body gaskets - leaking, damaged or incorrectly installed.

- b. Governor feed channels blocked.
  - c. 1-2 shift valve train stuck closed (in downshifted position).
- Intermediate Clutch:
    - a. Clutch piston seals - missing, improperly installed or cut.
    - b. Intermediate roller clutch - broken spring or damaged cage.
  - Case:
    - a. Porosity between channels.
    - b. Governor feed channel blocked; governor bore scored or worn, allowing cross pressure leak.

### First and Second Speeds Only - No 2-3 Shift

- Control Valve Assembly:
  - a. Valve body gaskets - leaking, damaged or incorrectly installed.
  - b. 2-3 shift valve train stuck closed (in downshifted position).
- Direct Clutch:
  - a. Pump hub - direct clutch oil seal rings - broken or missing.
  - b. Clutch piston seals - missing, improperly assembled or cut.
  - c. Clutch plates burned (see BURNED CLUTCH PLATES below).

### No First Speed - Starts in Second Speed

(Locks up in L1 Range)

Intermediate Clutch:

1. Too many plates in intermediate clutch pack.
2. Incorrect intermediate clutch piston.

### Drive in Neutral

- Manual Linkage - misadjusted, (correct alignment in manual lever shift quadrant is essential).
- Internal Linkage - manual valve disconnected or end broken.
- Oil Pump - line pressure leaking into forward clutch apply passage.
- Forward Clutch - incorrect clutch plate usage or burned clutches (see BURNED CLUTCH PLATES below).

### No Motion in Reverse or Slips in Reverse

(Install pressure gauge)

- Low Oil Level - add oil.
- Manual Linkage - misadjusted (correct alignment in manual lever shift quadrant is essential).

## 7A-42 AUTOMATIC TRANSMISSION

- Low Oil Pressure - refer to LOW LINE PRESSURE above.
- Control Valve Assembly:
  - a. Valve body gaskets - leaking, damaged or incorrectly installed.
  - b. 2-3 shift valve train stuck open (in upshifted position).
- Intermediate Servo - piston or pin stuck so intermediate overrun band is applied.
- Low and Reverse Clutch - piston outer seal damaged or missing.
- Direct Clutch:
  - a. Outer seal damaged or missing.
  - b. Clutch plates burned (see BURNED CLUTCH PLATES below).
- Forward Clutch - clutch does not release (will cause DRIVE in NEUTRAL).

### Slips in All Ranges or Slips on Start

(Install pressure gauge)

- Low Oil Level - add oil.
- Low Oil Pressure - refer to LOW LINE PRESSURE above.
- Forward clutch:
  - a. Clutch plates burned (see BURNED CLUTCH PLATES below).
  - b. Pump cover oil seal rings broken or worn.
- Case - cross leaks or porosity.

### Slipping 1-2 Shift

(Install pressure gauge)

- Low Oil Level - add oil.
- Low Oil Pressure - refer to LOW LINE PRESSURE above.
- 2-3 Accumulator - oil ring damaged or missing.
- 1-2 Accumulator - oil ring damaged, missing or case bore damaged.
- Pump-to-Case Gasket - mispositioned or damaged.
- Intermediate Clutch:
  - a. Piston seals damaged or missing.
  - b. Clutch plates burned (See BURNED CLUTCH PLATES below).
- Case - porosity between channels.

### Slipping 2-3 Shift

(Install pressure gauge)

- Low Oil Level - add oil.
- Low Oil Pressure - refer to LOW LINE PRESSURE above.
- Direct Clutch:

- a. Piston seals leaks, damaged or missing.
  - b. Clutch plates burned (see BURNED CLUTCH PLATES below).
  - c. Inspect for proper number and type of clutch plates.
- Case - refer to case porosity repair.

### Rough 1-2 Shift

(Install pressure gauge)

- High Oil Pressure - refer to HIGH LINE PRESSURE above.
- 1-2 Accumulator:
  - a. Oil rings damaged.
  - b. Piston stuck.
  - c. Broken or missing spring.
  - d. Bore damaged.
- Intermediate Clutch - check for burned and number (type) of plates.
- Case:
  - a. Check for correct number and location of check balls.
  - b. Porosity between channels.

### Rough 2-3 Shift

(Install pressure gauge)

- High Oil Pressure - refer to HIGH LINE PRESSURE above.
- 2-3 Accumulator:
  - a. Oil ring damaged.
  - b. Piston stuck.
  - c. Broken or missing spring.
  - d. Piston bore damaged.

### No Engine Braking in L2

(Install pressure gauge)

- Low Oil Pressure - pressure regulator and/or boost valve stuck.
- Intermediate Servo and 2-3 Accumulator:
  - a. Servo or accumulator oil rings or bores leaking or damaged.
  - b. Servo piston stuck or cocked.
- Intermediate Overrun Band - intermediate overrun band broken or burned (look for cause), not engaged or servo pin.

### No Engine Braking in L1

(Install pressure gauge)

- Low Oil Pressure - pressure regulator and/or boost valves stuck.
- Manual Low Control Valve Assembly - stuck.

- Low and Reverse Clutch - piston inner seal damaged or missing.

### No Part Throttle Downshift

(Install pressure gauge)

- Oil Pressure - vacuum modulator assembly, modulator valve or pressure regulator valve train (other malfunctions may also be noticed).
- Detent Valve and Linkage - sticks, disconnected or broken.
- 2-3 shift valve - stuck.

### No Detent (Wide Open Throttle) Downshift

- Detent cable or retainer not adjusted properly.
- Detent cable disconnected at transmission or throttle linkage.
- Valve Body:
  - a. Detent valve sticks.
  - b. Detent regulator valve sticks.
  - c. Incorrect spacer plate or gasket.

### High or Low Shift Points

(Install pressure gauge)

- Oil Pressure:
  - a. Engine Vacuum - check at transmission end of modulator pipe.
  - b. Check vacuum line connections at engine and transmission.
  - c. Vacuum modulator assembly and valve and pressure regulator valve train.
- Governor:
  - a. Valve sticking.
  - b. Feed holes restricted or leaking.
- Detent Valve and Linkage - stuck open (will cause high shift points).
- Control Valve Assembly:
  - a. 1-2 shift valve train sticking.
  - b. 2-3 shift valve train sticking.
- Case - refer to case porosity repair.

### Won't Hold in Park

- Manual Linkage - misadjusted (correct alignment in manual lever shift quadrant is essential).
- Internal Linkage:
  - a. Inner lever and actuating rod assembly - defective or improperly installed.

- b. Parking pawl - broken or inoperative.
- c. Parking lock bracket loose, burred or rough edges or incorrectly installed.
- d. Parking pawl disengaging spring missing, broken or incorrectly hooked.

### Transmission Noisy

**CAUTION:** Before checking transmission for noise, make certain that the noise is not coming from the water pump, alternator, power steering, etc. These components can be isolated by removing the proper belt and running the engine not more than two minutes at one time.

### Park, Neutral and all Driving Ranges

- Pump Cavitation:
  - a. Low oil level.
  - b. Plugged or restricted strainer.
  - c. Strainer-to-valve body gasket damaged.
  - d. Porosity in valve body intake area.
  - e. Water in oil.
  - f. Porosity or voids at transmission case (pump face) intake port.
  - g. Pump-to-case gasket off location.
- Pump Assembly:
  - a. Gears damaged.
  - b. Driving gear assembled backwards.
  - c. Crescent interference.
  - d. Oil seal rings damaged or worn.
- Converter:
  - a. Loose flexplate-to-converter bolts.
  - b. Converter damage.
  - c. Water in oil (causes whine).

### First, Second and/or Reverse Gear

Planetary Gear Set:

1. Gears or thrust bearings damaged.
2. Input or output ring gear damaged.

### During Acceleration - Any Gear

- Transmission or cooler lines grounded to underbody.
- Motor mounts loose or broken.

### Squeal at Low Vehicle Speed

Speedometer driven gear shaft seal - requires lubrication or replacement.

# TURBO HYDRA-MATIC 400/475 TRANSMISSION

## INDEX

General Description .....	7A-44	Modulator and Modulator Valve .....	7A-75
Theory of Operation .....	7A-45	Parking Linkage - 10, 20 Series .....	7A-76
Hydraulic System - Functions of Values and		Rear Seal .....	7A-76
Hydraulic Control Unit .....	7A-45	Other Service Operations .....	7A-76
Hydraulic Oil System .....	7A-55	Transmission Replacement .....	7A-76
Maintenance and Adjustment .....	7A-72	Diagnosis .....	7A-77
Checking Transmission Mount .....	7A-72	Sequence for Diagnosis .....	7A-77
Transmission Fluid .....	7A-72	Oil Checking Procedure .....	7A-77
Column Shift Linkage Adjustment .....	7A-73	Oil Leak Diagnosis .....	7A-77
Detent Switch Adjustment .....	7A-74	Oil Pressure Check .....	7A-78
Neutral Start Backup Lamp Switch Adjustment .....	7A-74	Case Porosity Repair .....	7A-78
Service Operations .....	7A-75	Vacuum Modulator Diagnosis .....	7A-78
Pressure Regulator Valve .....	7A-75	Manual Linkage .....	7A-80
Control Valve Body .....	7A-75	Trouble Diagnosis .....	7A-80
Governor .....	7A-75	Special Tools .....	7A-87-88

## GENERAL DESCRIPTION

The Turbo Hydra-Matic 400/475 transmission is a fully automatic unit consisting primarily of a 3-element hydraulic torque converter and a compound planetary gear set. Three multiple-disc clutches, one gear unit, one roller clutch, and two bands provide the friction elements required to obtain the desired function of the compound planetary gear set.

The torque converter couples the engine to the planetary gears through oil and provides hydraulic torque multiplication when required. The compound planetary gear set produces three forward speeds and reverse.

The 3-element torque converter consists of a pump or driving member, a turbine or driven member, and a stator assembly. The stator is mounted on a one-way roller clutch which will allow the stator to turn clockwise but not counter-clockwise.

The torque converter housing is filled with oil and is attached to the engine crankshaft by a flex plate and always rotates at engine speed. The converter pump is an integral part of the converter housing, therefore the pump blades, rotating at engine speed, set the oil within the converter into motion and direct it to the turbine, causing the turbine to rotate.

As the oil passes through the turbine it is traveling in such a direction that if it were not re-directed by the stator it would hit the rear of the converter pump blades and impede its pumping action. So at low turbine speeds, the oil is re-directed by the stator to the converter pump in such a manner that it actually assists the converter pump to deliver power or multiply engine torque.

As turbine speed increases, the direction of the oil leaving the turbine changes and flows against the rear side of the stator vanes in a clockwise direction. Since the stator is now impeding the smooth flow of oil, its

roller clutch releases and it revolves freely on its shaft. Once the stator becomes inactive, there is no further multiplication of engine torque within the converter. At this point, the converter is merely acting as a fluid coupling as both the converter pump and turbine are being driven at approximately the same speed - or at one-to-one ratio.

A hydraulic system pressurized by a gear type pump provides the working pressure required to operate the friction elements and automatic controls.

External control connections to transmission are:

Manual Linkage - To select the desired operating range.

Engine Vacuum - To operate a vacuum modulator unit.

12 Volt Electrical - To operate an electrical detent solenoid.

A vacuum modulator is used to automatically sense any change in the torque input to the transmission. The vacuum modulator transmits this signal to the pressure regulator for line pressure control, to the 1-2 accumulator valve, and to the shift valves so that all torque requirements of the transmission are met and smooth shifts are obtained at all throttle openings.

The detent solenoid is activated by an electric switch on the carburetor. When the throttle is fully opened, the switch on the carburetor is closed, activating the detent solenoid and causing the transmission to downshift for passing speeds.

The selector quadrant has six selector positions: P, R, N, D, L2, L1.

P. PARK position positively locks the output shaft to the transmission case by means of a locking pawl to



prevent the vehicle from rolling in either direction (not on CL model). The engine may be started in Park position.

- R. REVERSE enables the vehicle to be operated in a reverse direction.
- N. Neutral position enables the engine to be started and run without driving the vehicle.
- D. DRIVE Range is used for all normal driving conditions and maximum economy. Drive Range has three gear ratios, from the starting ratio to direct drive. Detent downshifts are available by depressing the accelerator to the floor.
- L2. L2 Range has the same starting ratio as Drive Range, but prevents the transmission from shifting ratio when extra performance is desired. L2 Range can also be used for engine braking. L2 Range can be selected at any vehicle speed, and the

transmission will shift to second gear and remain in second until the vehicle speed or the throttle are changed to obtain first gear operation in the same manner as in D Range.

- L1. L1 Range can be selected at any vehicle speed, and the transmission will shift to second gear and remain in second until vehicle is reduced to approximately 40 MPH, depending on axle ratio. L1 Range position prevents the transmission from shifting out of first gear.

NOTE: It is very important that any communication concerning the Turbo Hydra-Matic 400/475 always contain the transmission serial and vehicle identification number.

## THEORY OF OPERATION

### MECHANICAL POWER FLOW

Refer to figures 1T through 6T for related mechanical power flow. Each figure explains what component is applied or related in each stage of transmission operation.

### HYDRAULIC SYSTEM FUNCTIONS OF VALVES AND HYDRAULIC CONTROL UNITS

#### Pressure Control (Fig. 7T)

The transmission is automatically controlled by a hydraulic system. Hydraulic pressure is supplied by the transmission gear type oil pump, which is engine driven. Main line pressure is controlled by a pressure regulator valve train located in the pump. This regulator controls line pressure automatically, in response to a pressure signal from a modulator valve, in such a way that the torque requirements of the transmission are met and smooth shifts are obtained at all throttle openings.

To control line pressure properly, modulator pressure is used which varies in the same manner as torque input to the transmission. Since the converter torque output is the product of engine torque and converter ratio, modulator pressure must compensate for changes in either or both of these.

To meet these requirements, modulator pressure is regulated by engine vacuum which is an indicator of engine torque and carburetor opening. It is decreased by governor pressure with increase in vehicle speed because converter torque ratio also decreases.

#### Pressure Regulator Valve (Fig. 7T)

1. Regulates line pressure according to a fixed spring force and forces controlled by modulator and reverse pressure.

2. Controls the flow of oil that charges the torque converter, feeds the oil cooler and provides lubrication for the transmission.

#### Vacuum Modulator Assembly (Fig. 8T)

The engine vacuum signal is provided by the vacuum modulator, which consists of an evacuated metal bellows, a diaphragm and two springs. These are so arranged that when installed, the bellows and its external spring apply a force which acts on the modulator valve. This force acts on the modulator valve so that it increases modulator pressure. Engine vacuum and the internal spring act in the opposite direction to decrease modulator, or low engine vacuum high modulator pressure; high engine vacuum, and low modulator pressure.

To reduce the effect of altitude on shift points, the effective area of the diaphragm is made somewhat larger than that of the bellows. Atmospheric pressure then acts on the resulting differential area to reduce modulator pressure.

#### Governor Assembly (Fig. 9T)

The vehicle speed signal to the modulator valve is supplied by the transmission governor, which is driven by the output shaft. The governor consists of two flyweights and a regulator valve. Centrifugal force of the flyweights is imposed on the regulator valve causing it to regulate a pressure signal that increases with speed.

To increase the accuracy of the governor signal at low speeds, the flyweights are so designed that their effective mass is greater at speeds below approximately 720 output RPM than it is above this speed.

This is done by dividing each flyweight into two parts and arranging them so that the primary weights act through preloaded springs on the secondary weights,

## a. Operation of Components in Drive Range – First Gear

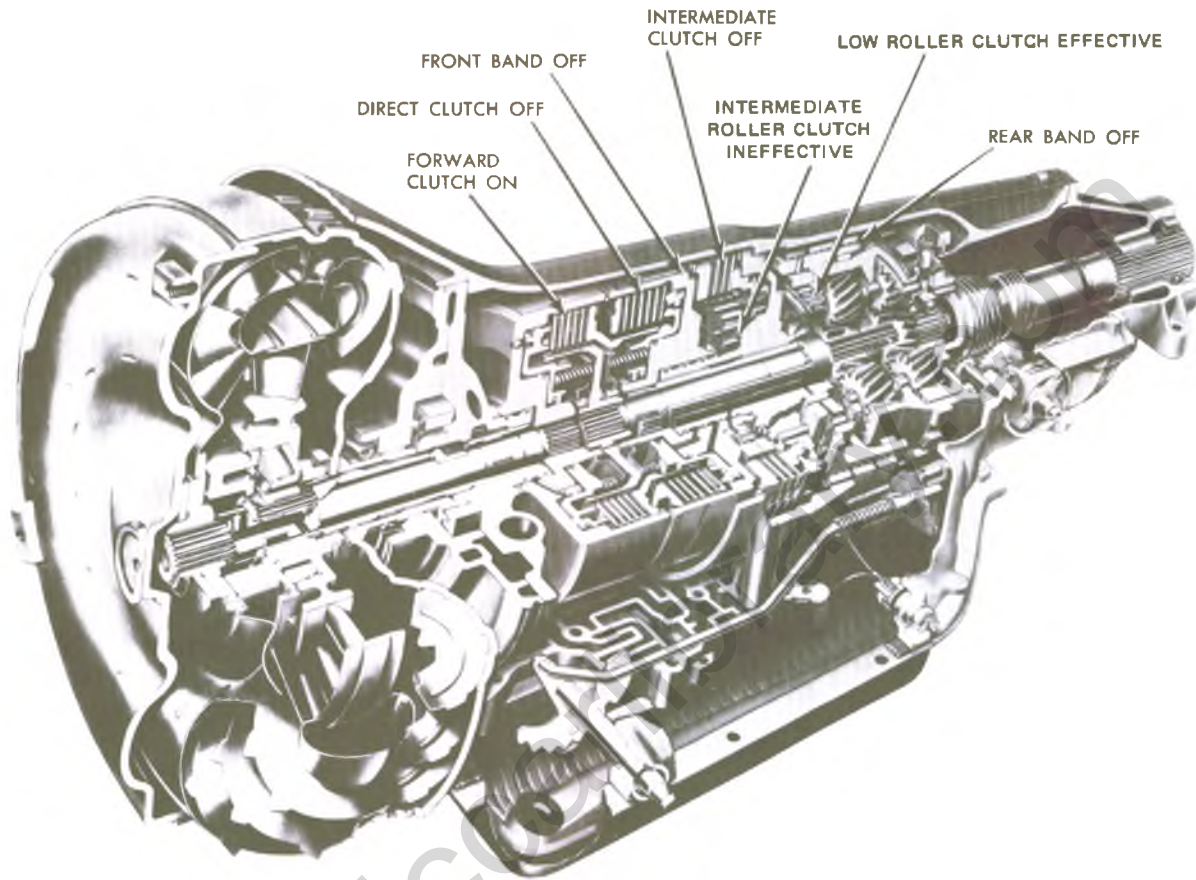

With the selector lever in Drive Range, the forward clutch is applied. This delivers turbine torque to the mainshaft and turns the rear internal gear in a clockwise direction. (Converter torque ratio = approximately 2.:1. at stall).

Clockwise motion of the rear internal gear causes the rear pinions to turn clockwise to drive the sun gear counterclockwise. In turn, the sun gear drives the front pinions clockwise, thus turning the front internal gear, output carrier, and output shaft clockwise in a reduction ratio of approximately 2.5:1. The reaction of the front pinions against the front internal gear is taken by the reaction carrier and one-way roller clutch assembly to the transmission case. (Approximate stall ratio = 5.:1.)

Fig. 1T—Drive Range - First Gear

## b. Operation of Components in Drive Range – Second Gear

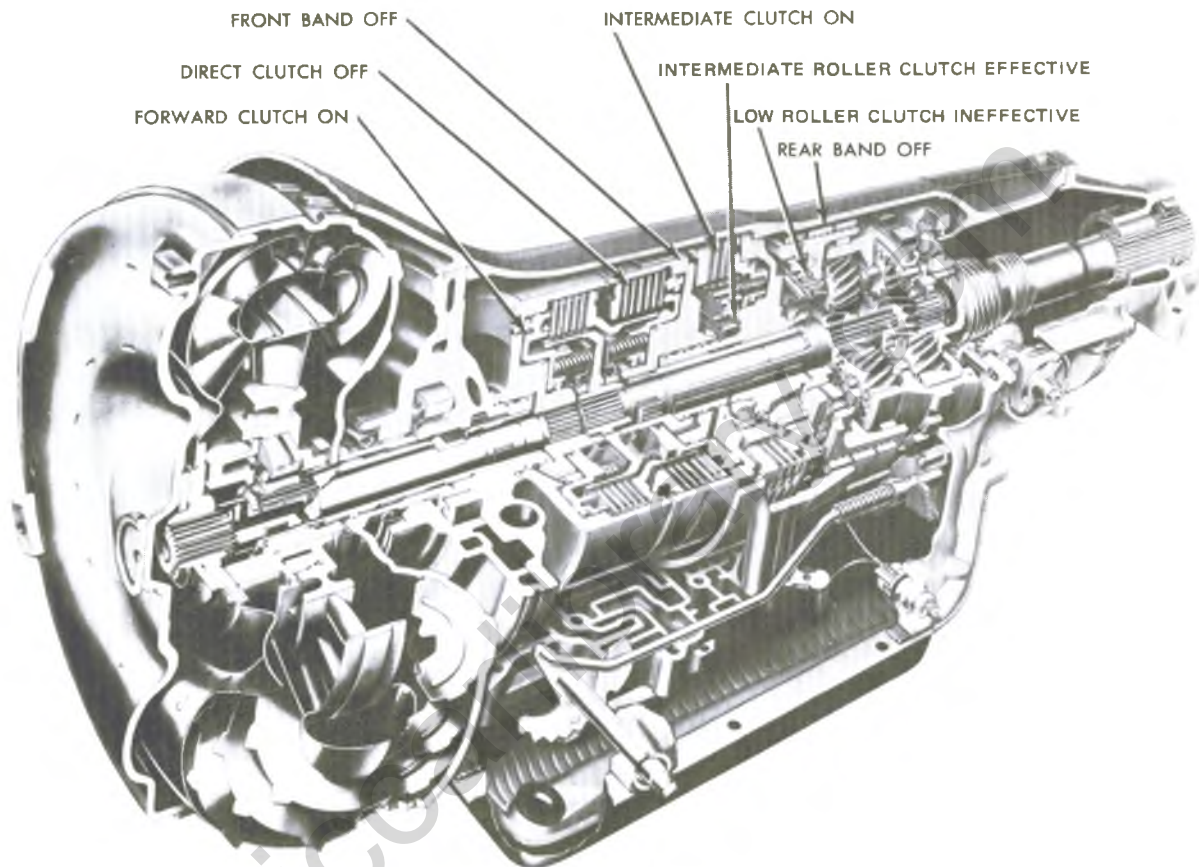

In second gear, the intermediate clutch is applied to allow the intermediate roller clutch to hold the sun gear against counterclockwise rotation. Turbine torque through the forward clutch is now applied through the mainshaft to the rear internal gear in a clockwise direction.

Clockwise rotation of the rear internal gear turns the rear pinons clockwise against the stationary sun gear. This causes the output carrier and output shaft to turn clockwise in a reduction ratio of approximately 1.5:1.

Fig. 2T—Drive Range - Second Gear

## c. Operation of Components in Drive Range — Third Gear

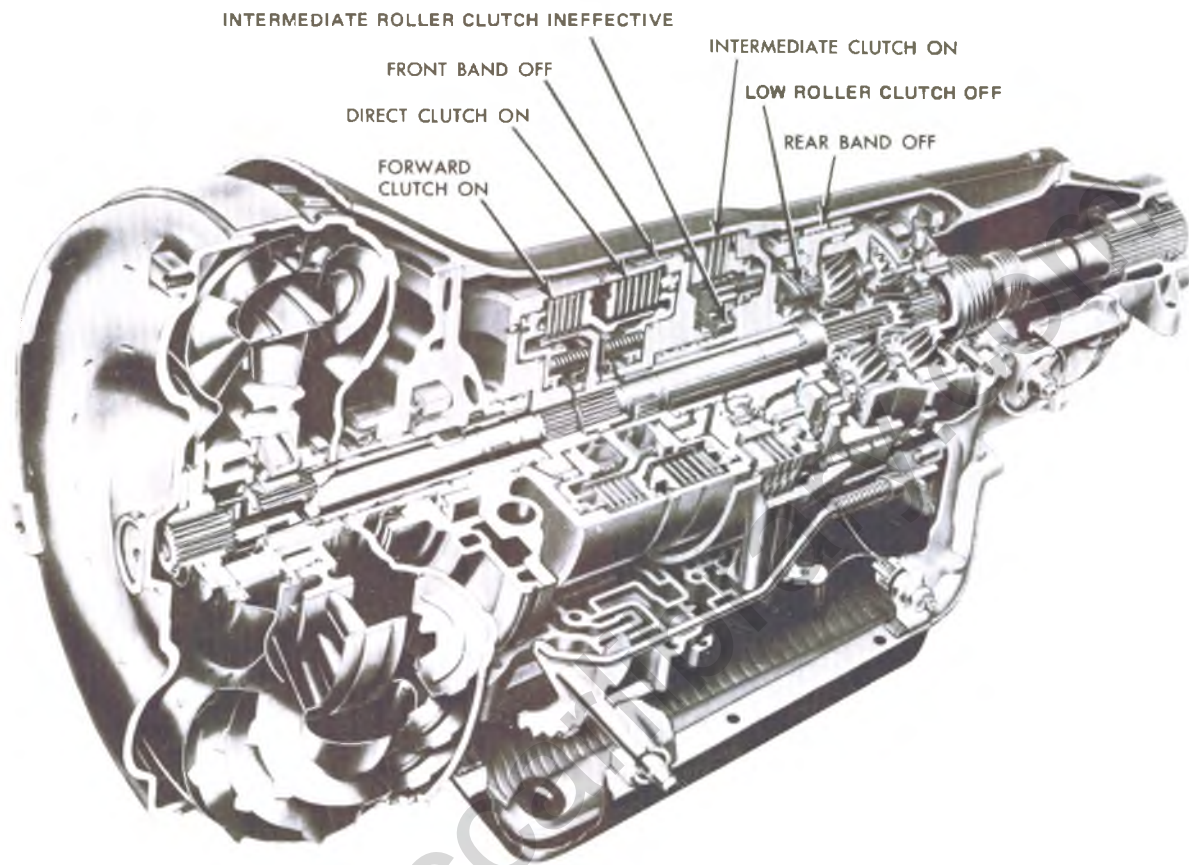

In direct drive, engine torque is transmitted to the converter through the forward clutch to the mainshaft and rear internal gear. Because the direct clutch is applied, equal power is also transmitted to the sun gear shaft and the sun gear. Since both the sun gear and internal gears are now turning at the same speed, the planetary gear set is essentially locked and turns as one unit in direct drive or a ratio of 1:1.

Fig. 3T—Drive Range - Third Gear

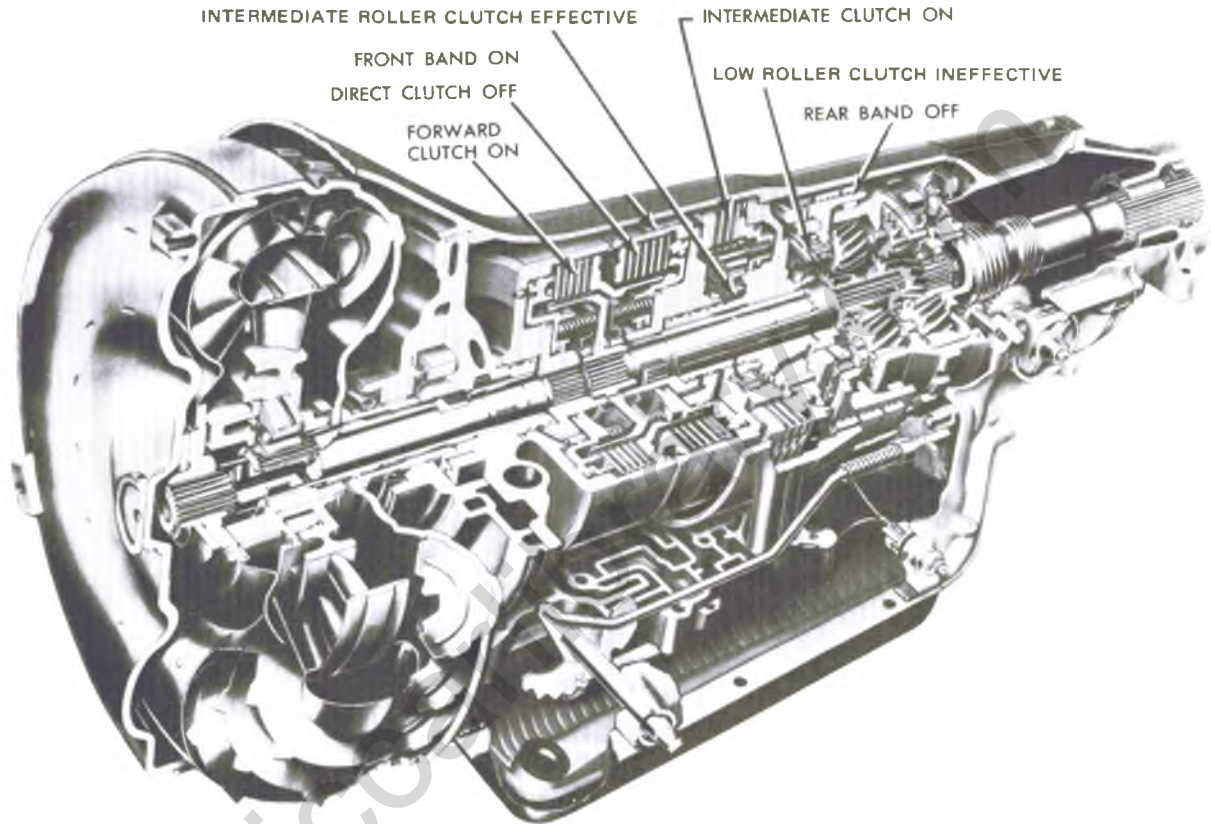
d. Operation of Components in Low — L<sup>2</sup> Range — Second Gear

In second gear, the intermediate clutch is applied to allow the intermediate roller clutch to hold the sun gear against counterclockwise rotation. Turbine torque through the forward clutch is now applied through the mainshaft to the rear internal gear in a clockwise direction.

Clockwise rotation of the rear internal gear turns the rear pinions clockwise against the stationary sun gear. This causes the output carrier and output shaft to turn clockwise in a reduction ratio of approximately 1.5:1.

In L<sup>2</sup> Range second gear, overrun braking is provided by the front band as it holds the sun gear fixed. Without the band applied, the sun gear would overrun the intermediate roller clutch.

Fig. 4T—L<sup>2</sup> Range · Second Gear

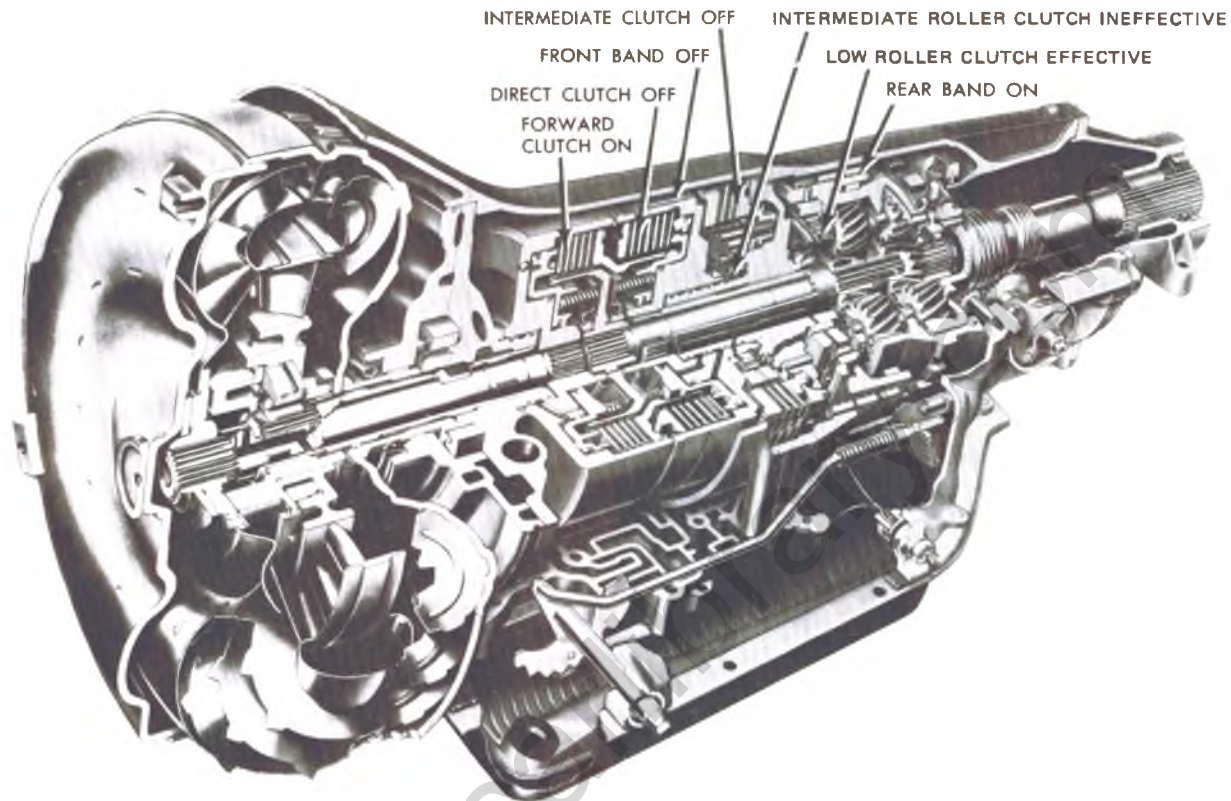
e. Operation of Components in Low – L<sup>1</sup> Range – First Gear

With the selector lever in L<sup>1</sup> Range, the forward clutch is applied. This delivers turbine torque to the mainshaft and turns the rear internal gear in a clockwise direction. (Converter torque ratio = approximately 2.:1. at stall.)

Clockwise motion of the rear internal gear causes the rear pinions to turn clockwise to drive the sun gear counterclockwise. In turn, the sun gear drives the front pinions clockwise, thus turning the front internal gear, output carrier, and output shaft clockwise in a reduction ratio of approximately 2.5:1. The reaction of the front pinions against the front internal gear is taken by the reaction carrier and the low roller clutch. (Total stall ratio = approximately 5.:1.)

Downhill or overrun braking is provided in L<sup>1</sup> Range by applying the rear band as this prevents the reaction carrier from overrunning the low roller clutch.

Fig. 5T—L<sup>1</sup> Range - First Gear

## f. Operation of Components in Reverse

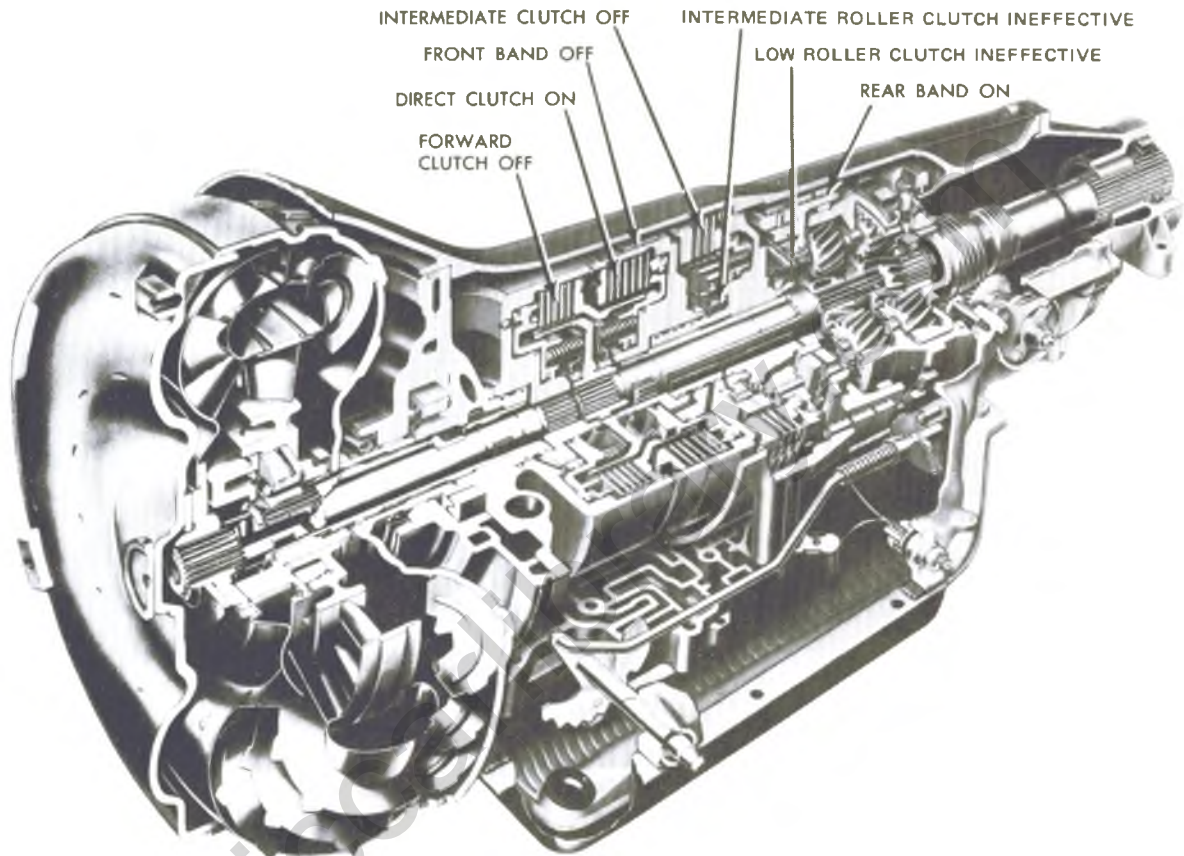

In Reverse, the direct clutch is applied to direct turbine torque to the sun gear shaft and sun gear. The rear band is also applied, holding the reaction carrier.

Clockwise torque to the sun gear causes the front pinions and front internal gear to turn counter-clockwise in reduction. The front internal gear is connected directly to the output shaft, thus providing the reverse output gear ratio of approximately 2.:1. The approximate reverse torque multiplication at stall (converter and gear ratios) is approximately 4.:1.

Fig. 6T—Reverse

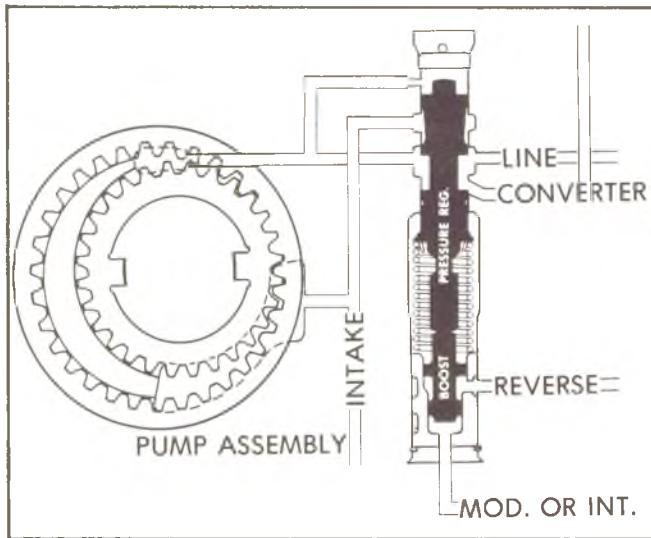

Fig. 7T—Pump and Pressure Regulator Valve

which in turn acts on the valve. At approximately 720 RPM the centrifugal force on each primary weight exceeds the spring force and the primary weights move to a grounded stop. With the primary weights grounded, the force on the governor regulator valve is equal to the spring forces, plus the centrifugal force on the secondary weights.

Governor pressure acts on the modulator valve to cause modulator pressure to decrease as vehicle speed increases.

**Manual Valve (Fig. 10T)**

Establishes the range of transmission operation, i.e. P, R, N, D, L2, L1, as selected by the vehicle operator through the manual control lever.

**Modulator Valve (Fig. 8T)**

Regulates line pressure to modulator pressure that varies with torque to the transmission. It senses forces created by:

1. The vacuum modulator bellows that increases modulator pressure.
2. Engine vacuum acting on a diaphragm to decrease modulator pressure.
3. Governor pressure which is generated by the governor assembly. Governor pressure tends to decrease modulator pressure.

**1-2 Shift Valve (Fig. 11T)**

Controls the oil pressure that causes the transmission to shift from 1-2 or 2-1. Its operation is controlled by governor pressure, low oil pressure, detent pressure, modulator pressure, and spring force.

**Regulator Valve (Fig. 11T)**

Regulates modulator pressure to a pressure proportional to modulator pressure, tending to keep the 1-2 shift valve in the downshift position.

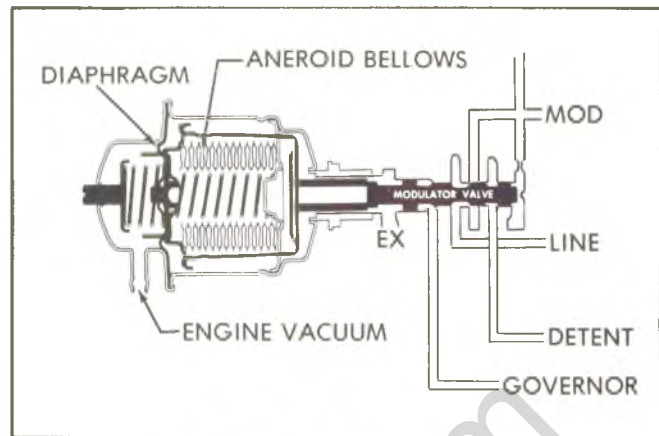

Fig. 8T—Vacuum Modulator Assembly

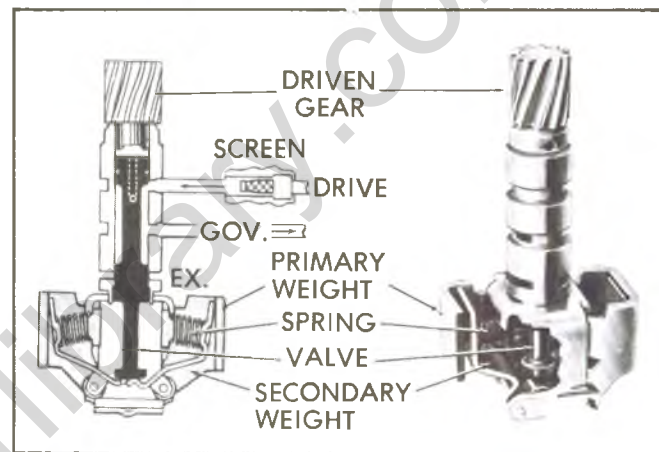

Fig. 9T—Governor Assembly

**1-2 Detent Valve (Fig. 11T)**

Senses regulated modulator pressure tending to hold the 1-2 shift valve in the downshift position and provides an area for detent pressure for detent 2-1 shifts.

**2-3 Shift Valve (Fig. 12T)**

Controls the oil pressure that causes the transmission to shift from 2-3 or 3-2. Its operation is controlled by modulator, L2, governor and detent pressure as well as a spring force.

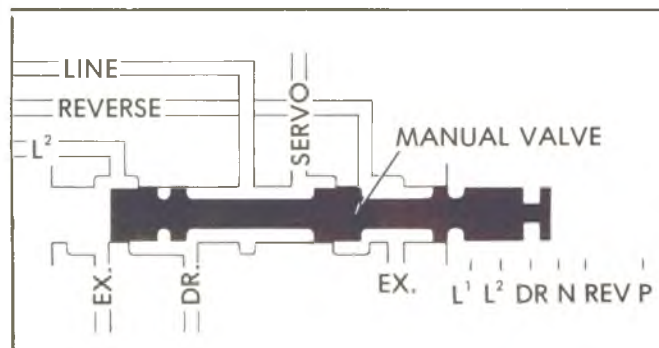

Fig. 10T—Manual Valve



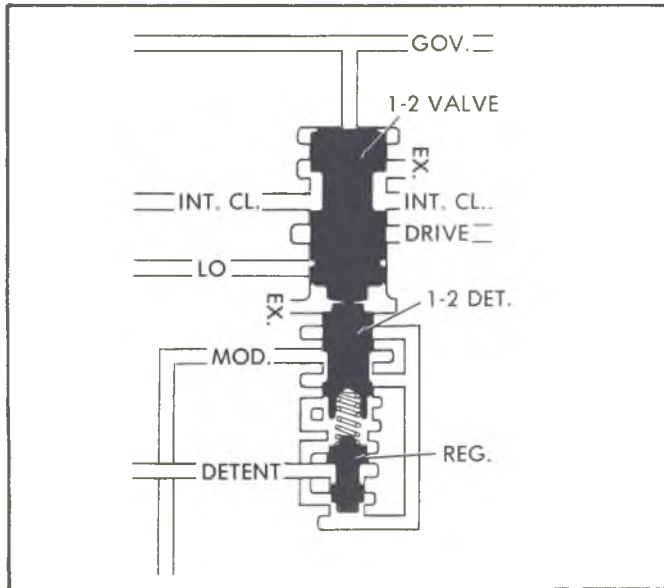

Fig. 11T-1-2 Shift Valve and 1-2 Detent Valve and Regulator Valve (Typical)

**2-3 Modulator Valve (Fig. 12T)**

Senses modulator pressure to apply a variable force proportional to modulator pressure which tends to hold the 2-3 shift valve downshifted.

**3-2 Valve (Fig. 13T)**

Shuts off modulator pressure from acting on the shift valve trains after the direct clutch has been applied. This allows fairly heavy throttle operation in third gear without downshifting. In third speed, modulator pressure or detent pressure above 87 psi will provide part throttle downshift forces. (Resulting in a 3-2 downshift at less than wide open throttle).

**Detent Valve (Fig. 14T)**

Shifts when line oil is exhausted at the end of the valve when the detent solenoid is energized, thus allowing the detent regulator valve to regulate. This directs detent pressure to the 1-2 accumulator valve, 1-2 regulator and 2-3 modulator valves, 3-2 valve, and the vacuum modulator valve.

**Detent Regulator Valve (Fig. 14T)**

When the detent valve shifts, the detent regulator is free to allow drive oil to enter the detent passage and thus becomes regulated to a value of 70 psi. Detent pressure will also flow into the modulator passage which flows to the 2-3 modulator valve, 3-2 valve and the 1-2 detent valve. L1 oil moves the detent regulator open to drive oil allowing drive oil to enter the modulator and detent passages.

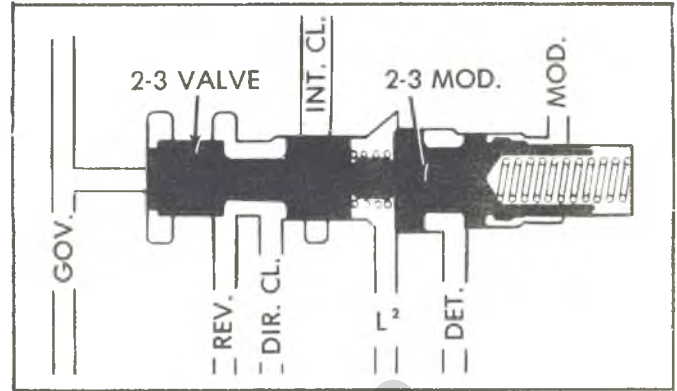

Fig. 12T-2-3 Valve and 2-3 Modulator Valve Train (Typical)

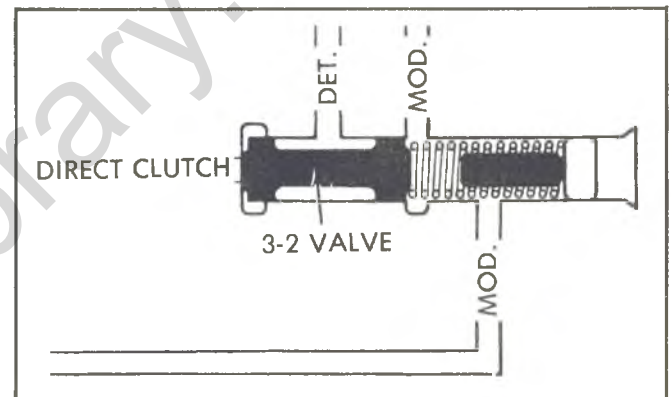

Fig. 13T-3-2 Valve

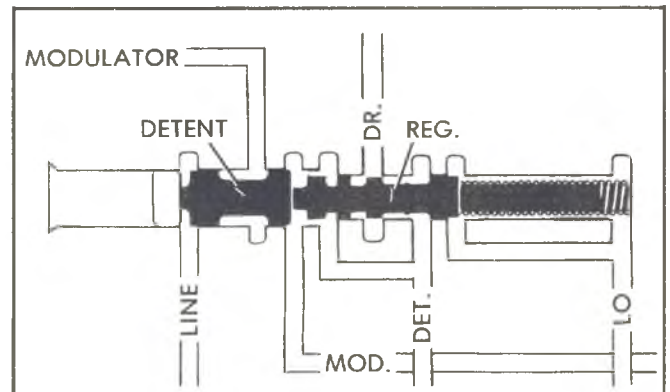

Fig. 14T-Detent Valve and Detent Regulator Valve

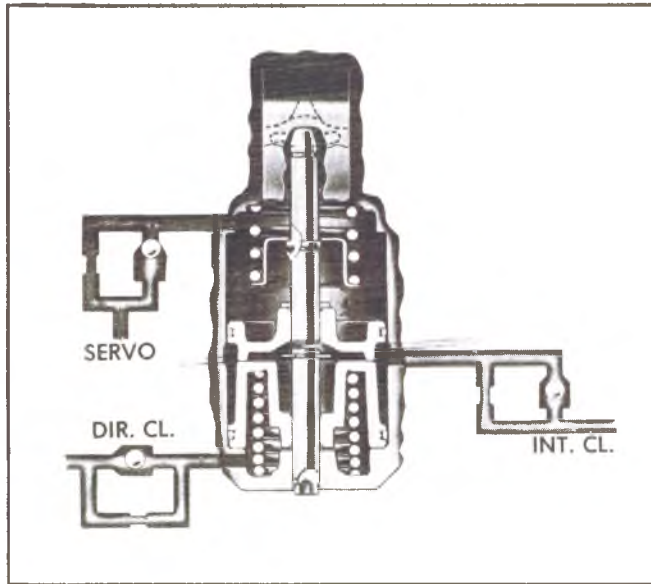

Fig. 15T—Front Servo

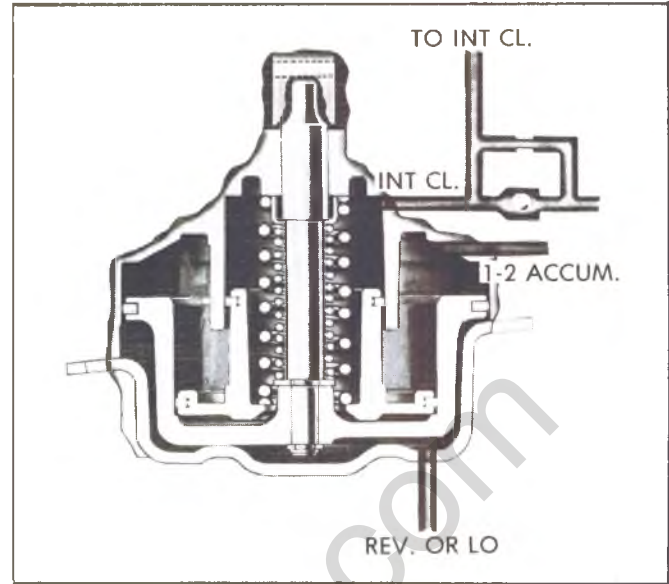

Fig. 16T—Rear Servo

### Front Servo (Fig. 15T)

The front servo applies the front overrun band to provide engine braking in 2nd gear in L2 Range. It is also used as an accumulator for the application of the direct clutch and in conjunction with a series of check balls and controlling orifices is a part of the timing for the release of the direct clutch.

To prevent the application of the front overrun band in Neutral, Drive and Reverse ranges, oil is directed from the manual valve to the release side of the servo piston.

In Drive range the servo release oil from the manual valve also acts to charge the servo in preparation for the application of the direct clutch.

Direct clutch oil is directed to the front servo accumulator piston where spring force plus direct clutch pressure stroke the piston up against the force of servo

release oil. This lowers the clutch apply pressure during the shift for a smooth engagement.

The release of the direct clutch and the exhausting of the front servo accumulator is slowed down by three check balls and three orifices which permits a soft return of the drive load to the intermediate roller clutch and also allows engine RPM to increase during a detent 3-2 downshift in preparation for the lower gear ratio, which results in a smooth shift and better acceleration.

### Rear Servo (Fig. 16T)

The rear servo applies the rear band for overrun engine braking in L1 range 1st gear. It applies the band in Reverse to hold the reaction carrier to provide the reverse gear ratio.

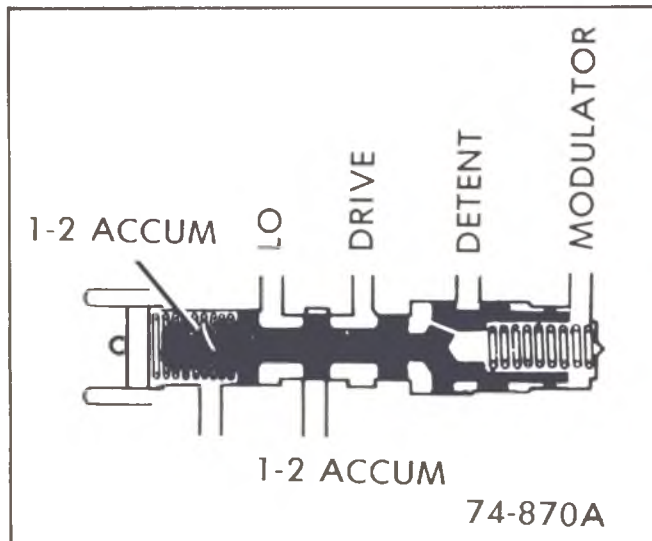

Fig. 17T—1-2 Accumulator Valve Train (Typical)

### 1-2 Accumulator (Fig. 17T)

1-2 accumulator oil charges the rear servo accumulator in 1st gear in preparation for the apply of the intermediate clutch on the 1-2 shift.

The valve train consists of a 1-2 primary valve and spring, a 1-2 accumulator valve and spring and plug.

1-2 accumulator oil pressure is a two-stage pressure which increases as modulator pressure increases to obtain greater flexibility in obtaining the desired curve during the 1-2 shift for various engine requirements.

### HYDRAULIC OIL SYSTEM

Refer to figure 18T through 25T for an explanation of the hydraulic oil system that applies the clutches and bands and controls the automatic shifting.

classiccarlibrary.com

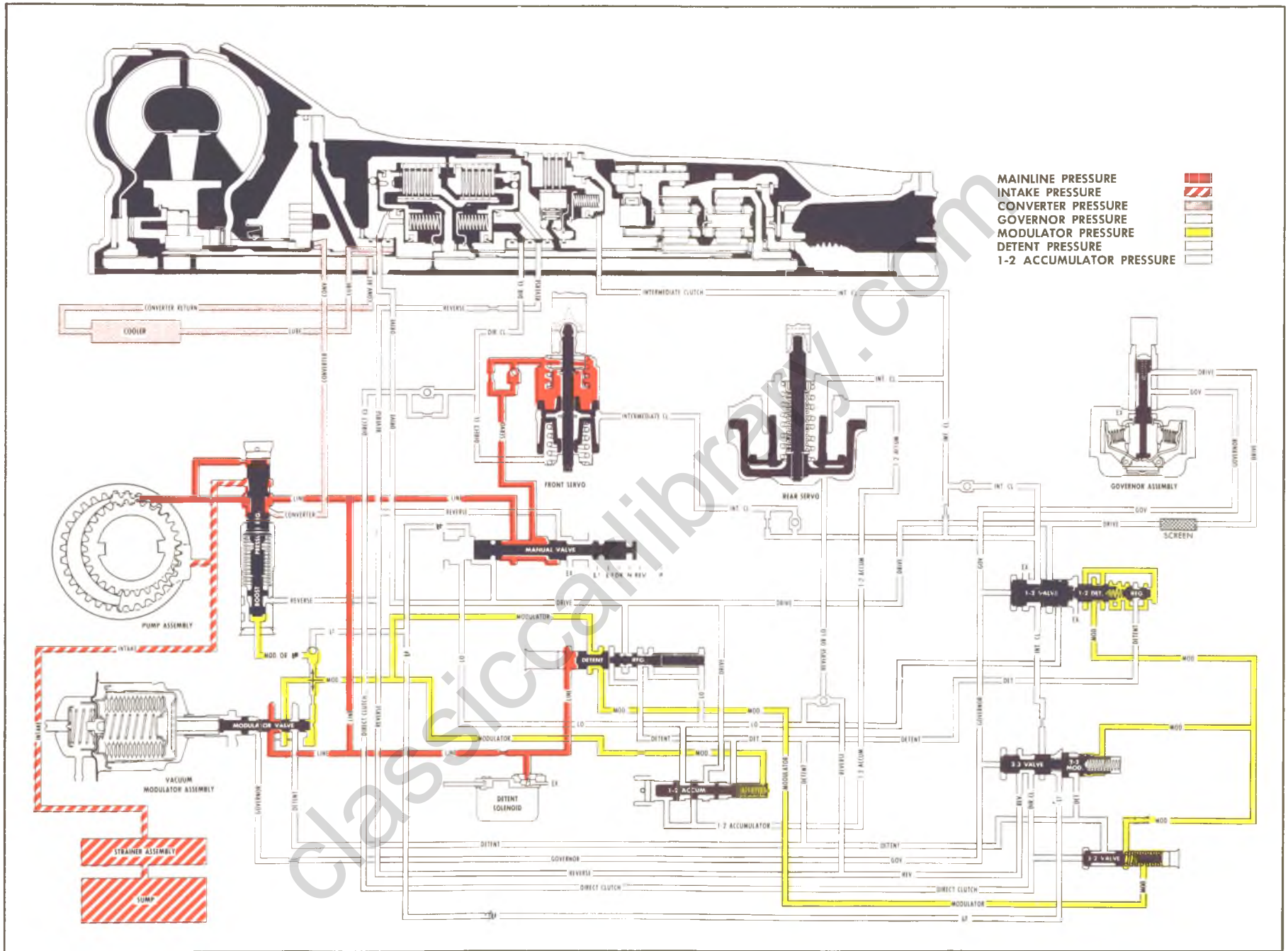

Fig. 18T—Neutral Range · Engine Idling Typical

**NEUTRAL RANGE-ENGINE IDLING****Power Flow**

Forward Clutch - Off

Roller Clutch - Ineffective

Direct Clutch - Off

Front Band - Off

Rear Band - Off

Intermediate Roller Clutch - Ineffective

Detent Solenoid - De-energized

In Neutral or Park, no bands or clutches are applied. Therefore no power is transmitted.

**Oil Flow**

Whenever the engine is running at idle with the selector lever in P or N, oil from the pump is directed to the:

1. Pressure Regulator Valve
2. Converter:
  - a. Oil Cooler
  - b. Lubrication System
3. Manual Valve
4. Detent Valve
5. Detent Solenoid

6. Vacuum Modulator Valve

7. Front Servo (Neutral only)

**Basic Control**

Oil flows from the pump to the pressure regulator valve which regulates pump pressure. When the pump output exceeds the demand of line pressure, oil from the pressure regulator is directed to the converter feed passage to fill the converter. Oil from the converter is directed to the transmission cooler. Oil from the cooler is directed to the transmission lubrication system.

Line pressure acts on the:

1. Manual Valve
2. Detent Valve
3. Detent Solenoid
4. Modulator Valve
5. Front Servo Piston (Neutral Only)

Line pressure at the modulator valve is re-regulated to modulator oil, which acts on the pressure boost valve and 1-2 accumulator valve train and passes through the detent valve and 3-2 valve to the 1-2 and 2-3 valve trains.

**Summary**

The converter is filled and all clutches and bands are released. The transmission is in Neutral or Park.

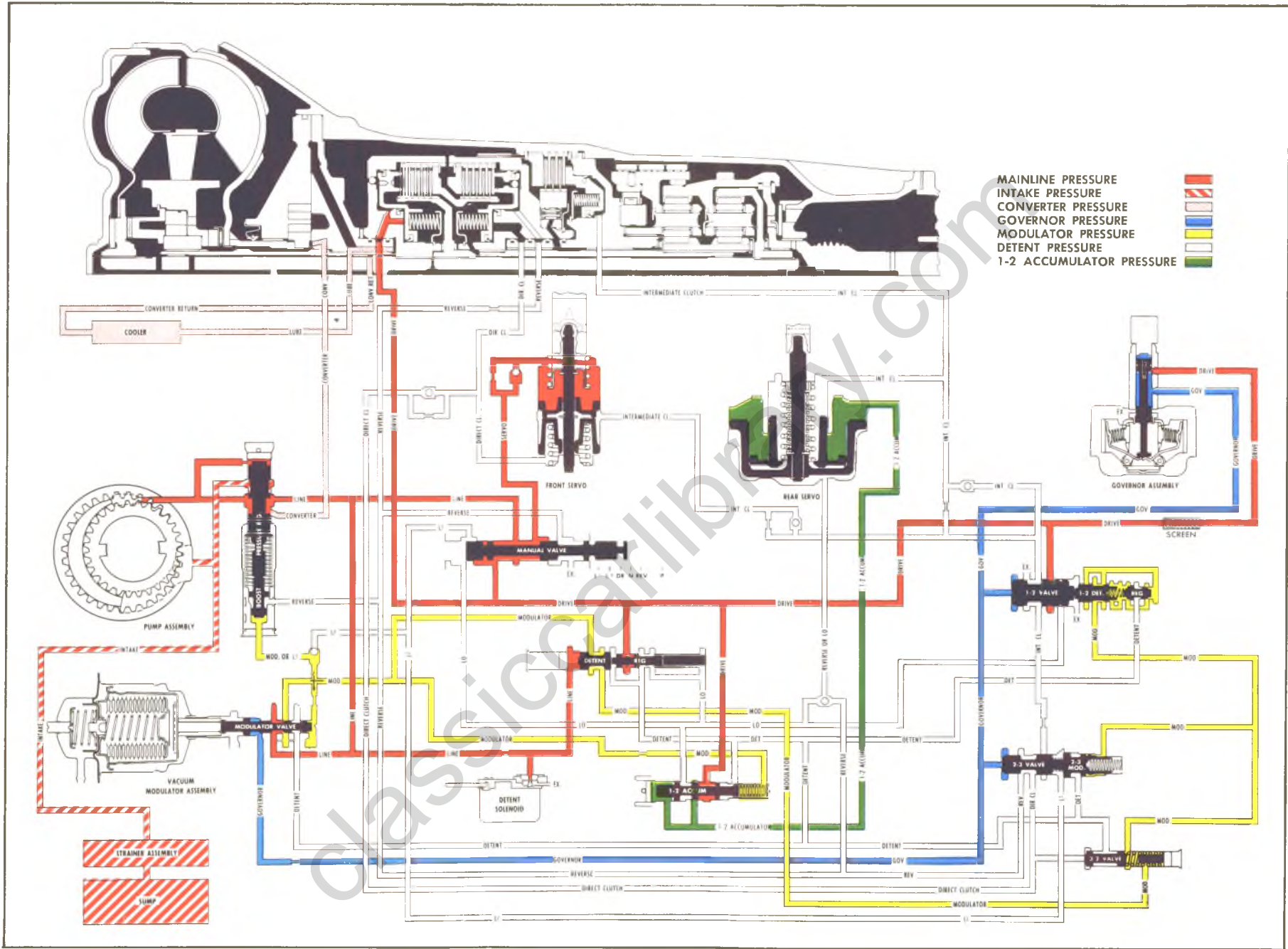

Fig. 19T—Drive Range - First Gear Typical

**DRIVE RANGE-FIRST GEAR****Power Flow**

Forward Clutch - On

Low Roller Clutch - Effective

Direct Clutch - Off

Front Band - Off

Rear Band - Off

Intermediate Clutch - Released

Intermediate Roller Clutch - Ineffective

Detent Solenoid - De-energized

With the selector lever in any forward range, the forward clutch is applied. This delivers turbine torque to the mainshaft and turns the rear internal gear in a clockwise direction, viewed from front (Converter torque ratio equals approximately 2:1 at stall).

Clockwise motion of the rear internal gear causes the rear pinions to turn clockwise, driving the sun gear counterclockwise. In turn, the sun gear drives the front pinions clockwise, thus turning the front internal gear, output carrier and output shaft clockwise in a reduction ratio of approximately 2.5:1.

Reaction of the front pinions against the front internal gear is taken by reaction carrier and roller clutch assembly to the transmission case (Approximate stall ratio equals 5:1).

**Oil Flow**

When the selector lever is moved to Drive position, the

manual lever is repositioned to allow line pressure to enter the drive circuit. Drive oil then flows to the:

1. Forward Clutch
2. 1-2 Shift Valve
3. Governor Assembly
4. 1-2 Accumulator Valve
5. Detent Regulator Valve

**Basic Control**

Drive oil is directed to the forward clutch where it acts on two areas of the clutch piston to apply the forward clutch. The inner area is fed through an unrestricted passage. The outer area is fed through an orifice to insure a smooth shift from Park, Neutral and Reverse to Drive.

Drive oil at the governor assembly is regulated to a variable pressure. This pressure increases with vehicle speed and acts against the ends of the 1-2 and 2-3 shift valves and an area on the modulator valve. This variable pressure is called governor pressure.

Drive oil is also regulated to another variable pressure at the 1-2 accumulator valve. This pressure, called 1-2 accumulator oil, is controlled by modulator oil and is directed to the rear servo. 1-2 accumulator oil at the rear servo acts on the accumulator piston.

**Summary**

The converter is filled and the forward clutch is applied. The transmission is in Drive range - first gear.

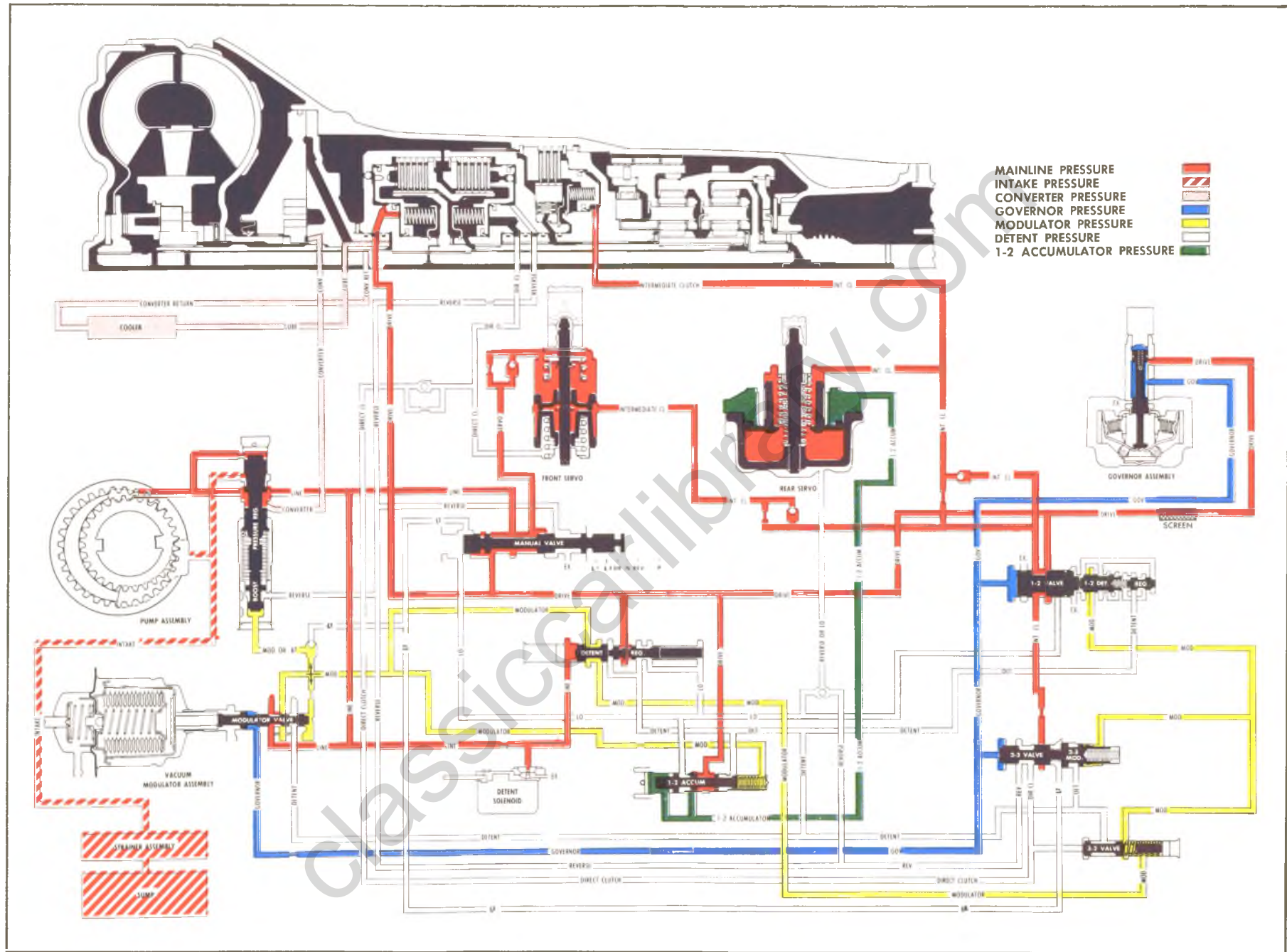

Fig. 20T—Drive Range - Second Gear Typical



**DRIVE RANGE-SECOND GEAR****Power Flow**

Forward Clutch - On

Low Roller Clutch - Ineffective

Direct Clutch - Off

Front Band - Off

Rear Band - Off

Intermediate Clutch - On

Intermediate Roller Clutch - Effective

Detent Solenoid - De-energized

In second gear, the intermediate clutch is applied to allow the intermediate roller to hold the sun gear against counterclockwise rotation. Turbine torque, through the forward clutch, is applied through the mainshaft to the rear internal gear in a clockwise direction.

Clockwise rotation of the rear internal gear turns the rear pinions clockwise against the stationary sun gear. This causes the output carrier and output shaft to turn clockwise in a reduction ratio of approximately 1.5:1.

**Oil Flow**

As both vehicle speed and governor pressure increase, the force of governor oil acting on the 1-2 shift valve will overcome the force of re-regulated modulator oil

pressure. This allows the 1-2 shift valve to open, permitting drive oil to enter the intermediate clutch passage.

Intermediate clutch oil from the 1-2 shift valve is directed to the:

1. Intermediate Clutch
2. Rear Servo
3. Front Servo and Accumulator Pistons
4. 2-3 Shift Valve

**Basic Control**

Intermediate clutch oil from the 1-2 shift valve seats a one-way check ball and flows through an orifice to the intermediate clutch piston to apply the intermediate clutch. At the same time, intermediate clutch oil moves the accumulator piston against the 1-2 accumulator oil.

The accumulator spring maintains controlled pressure in the clutch during a 1-2 shift for a smooth clutch apply. Intermediate clutch oil seats a second one-way check ball and flows to the front servo and accumulator pistons. Intermediate clutch oil is also directed to a land of the 2-3 shift valve.

**Summary**

The forward and intermediate clutches are applied. The transmission is in second gear.

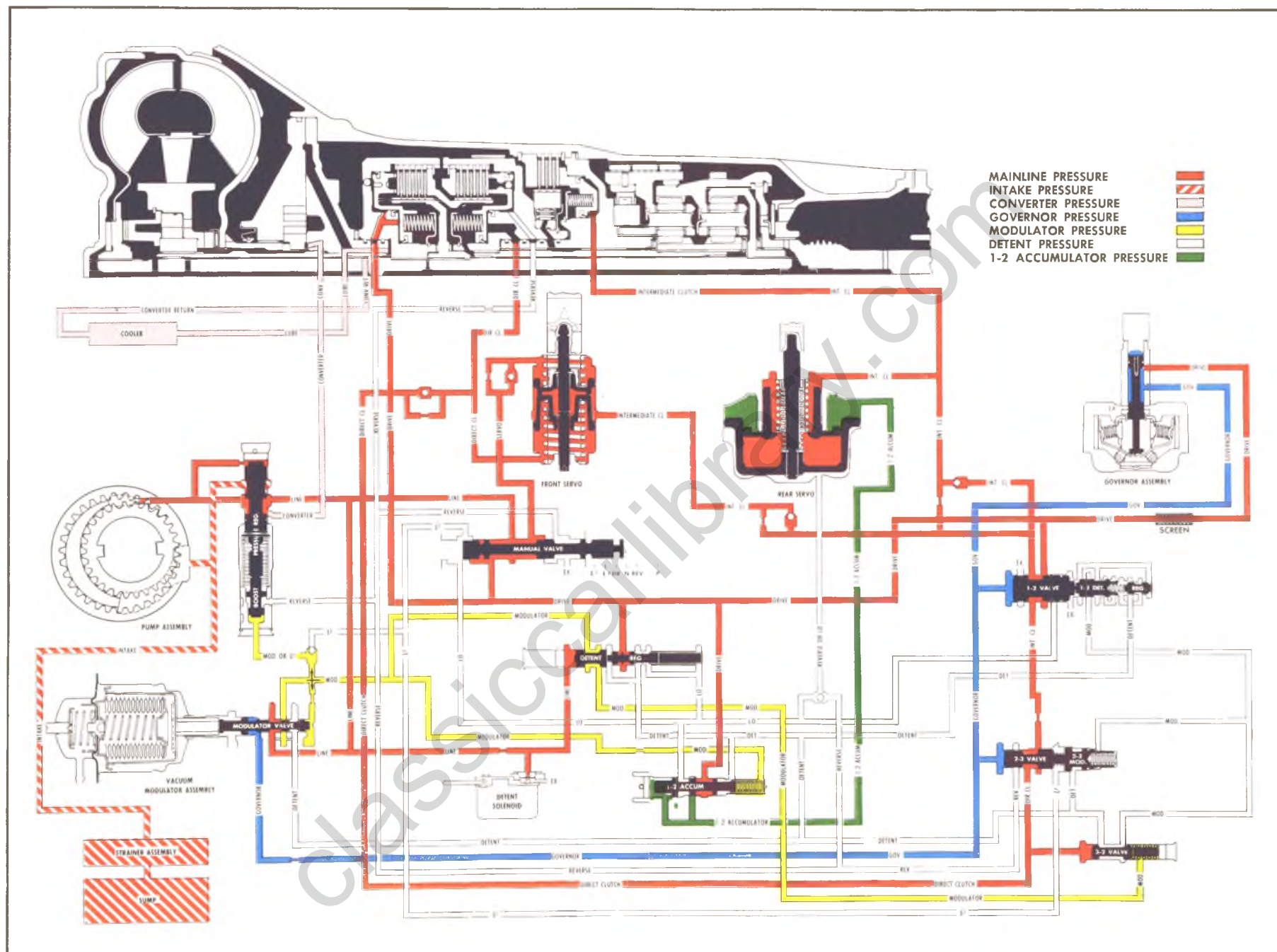

Fig. 21T—Drive Range - Third Gear Typical

**DRIVE RANGE-THIRD GEAR****Power Flow**

Forward Clutch - On

Low Roller Clutch - Ineffective

Direct Clutch - On

Front Band - Off

Rear Band - Off

Intermediate Clutch - On

Intermediate Roller Clutch - Ineffective

Detent Solenoid - De-energized

In direct drive, engine torque is transmitted to the converter through the forward clutch to the mainshaft and rear internal gear. Because the direct clutch is applied, torque is also transmitted to sun gear shaft and sun gear. Since both sun gear and internal gears are now turning at the same speed, the planetary gear set is essentially locked and turns as one unit in direct drive or a ratio of 1:1.

**Oil Flow**

As vehicle speed and governor pressure increase, force of governor oil acting on the 2-3 shift valve overcomes the force of 2-3 shift valve spring and modulator oil. This allows the 2-3 shift valve to move, feeding intermediate clutch oil to the direct clutch passage.

Direct clutch oil from the 2-3 shift valve is directed to the:

1. Direct Clutch
2. Front Accumulator Piston
3. 3-2 Valve

**Basic Control**

Direct clutch oil from the 2-3 shift valve flows past a one-way check valve to the inner area of the direct clutch piston to apply the direct clutch. Simultaneously, direct clutch oil is fed to the front accumulator piston. Pressure of the direct clutch oil, combined with the accumulator spring, moves the accumulator and servo pistons against servo oil. This acts as an accumulator for a smooth direct clutch apply.

Direct clutch oil is also supplied to the 3-2 valve to move the valve against modulator pressure. This cuts off modulator oil to the 1-2 and 2-3 shift valve trains and allows the transmission to utilize the torque multiplying characteristics of the converter during medium throttle operation without downshifting.

**Summary**

The forward, intermediate and direct clutches are applied. The transmission is in third gear (direct drive).

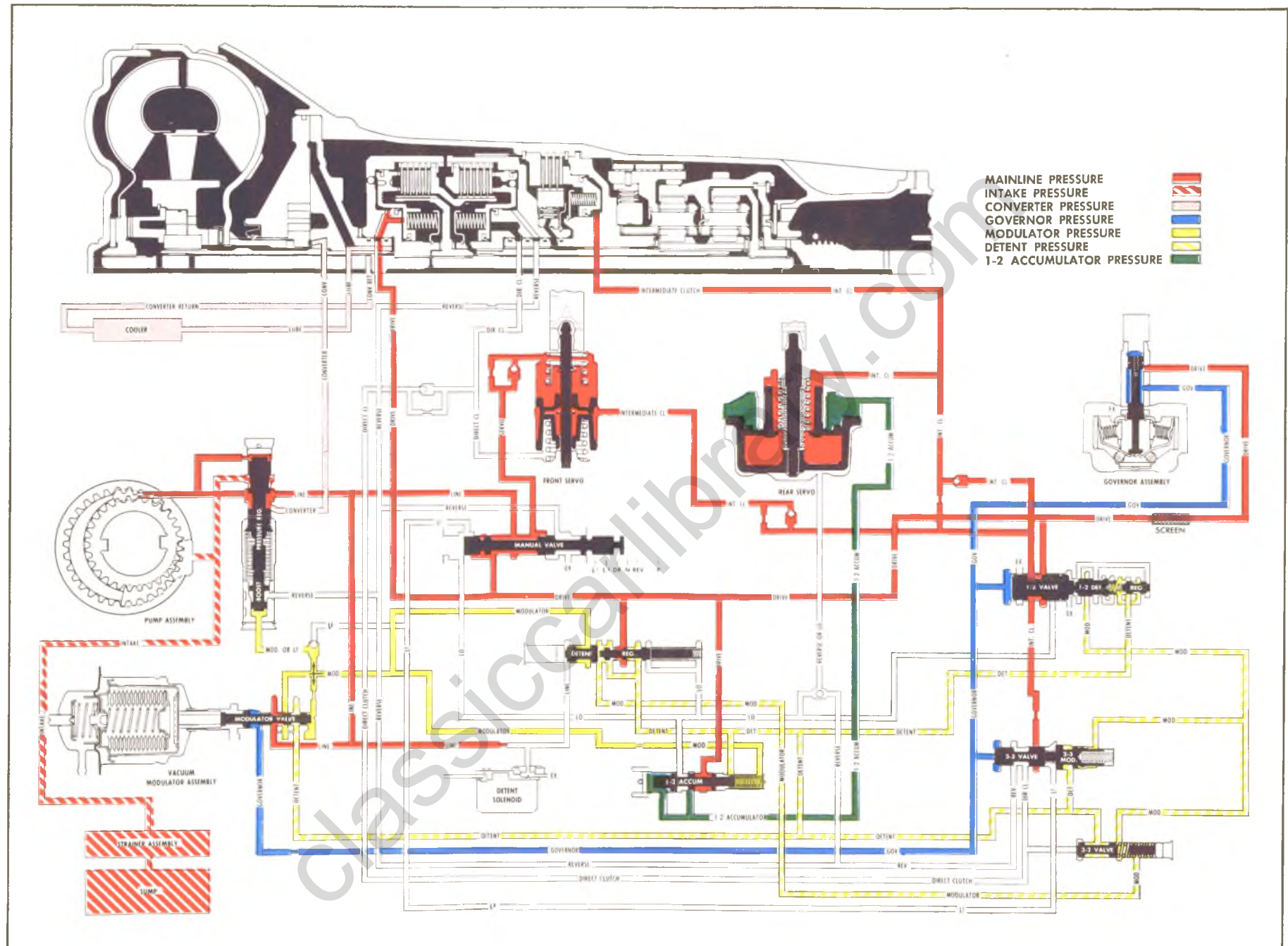

Fig. 22T—Detent Downshift (Valves in Second Gear Position) Typical

**DETENT DOWNSHIFT****(Valves in Second Gear Position)****Power Flow**

Forward Clutch - On  
 Low Roller Clutch - Ineffective  
 Direct Clutch - Off  
 Front Band - Off  
 Rear Band - Off  
 Intermediate Clutch - On  
 Intermediate Roller Clutch - Effective  
 Detent Solenoid - Energized

In second gear, the intermediate clutch is applied to allow the intermediate roller to hold the sun gear against counterclockwise rotation. Turbine torque, through the forward clutch, is now applied through the mainshaft to the rear internal gear in a clockwise direction.

Clockwise rotation of the rear internal gear turns the rear pinions clockwise against the stationary sun gear. This causes the output carrier and output shaft to turn clockwise in a reduction ratio of approximately 1.5:1.

**Oil Flow**

While operating at speeds below approximately 70 mph, a forced or detent 3-2 downshift is possible by depressing the accelerator fully. This engages an electrically operated switch and actuates the detent solenoid. The detent solenoid opens an orifice that allows line oil at the detent valve to be exhausted, thus permitting the detent regulator valve to operate. Line oil acting on the detent valve and solenoid is supplied by a small orifice.

Drive oil on the detent regulator valve is then regulated to a pressure of approximately 70 psi and called detent oil. Detent oil is then routed to the:

1. Modulator Passage
2. 1-2 Regulator Valve
3. 2-3 Modulator Valve
4. 3-2 Valve

5. 1-2 Primary Accumulator Valve

6. Vacuum Modulator Valve

Detent oil in the modulator passage and at the 2-3 modulator valve will close the 2-3 valve, shifting the transmission to second gear (below approximately 70 mph).

A detent 2-1 downshift can also be accomplished below approximately 20 mph because detent oil is directed to the 1-2 regulator valve. This allows detent oil to act on the 1-2 regulator and 1-2 detent valve to close the 1-2 shift valve, shifting the transmission to first gear.

To insure clutch durability during 1-2 upshifts under detent conditions, detent oil is directed to the 1-2 accumulator primary valve to increase 1-2 accumulator oil pressure acting on the rear servo accumulator piston.

Detent oil is also directed to the modulator valve to prevent modulator pressure from regulating below 70 psi at high speed or at high altitudes.

**Part Throttle 3-2 Downshifts**

Forward Clutch - On

Low Roller Clutch - Ineffective

Direct Clutch - Off in 2nd

Direct Clutch - On in 3rd

Front Band - Off

Rear Band - Off

Intermediate Clutch - On

Intermediate Roller Clutch - Effective in 2nd

Intermediate Roller Clutch - Ineffective in 3rd

A part throttle 3-2 downshift can be accomplished below approximately 33 mph by depressing the accelerator far enough to raise modulator pressure to approximately 87 psi. Modulator pressure and the 3-2 valve spring will move the 3-2 valve against direct clutch oil and allow modulator oil to act on the 2-3 modulator valve. This moves the 2-3 valve train against governor oil and shifts the transmission to second speed.

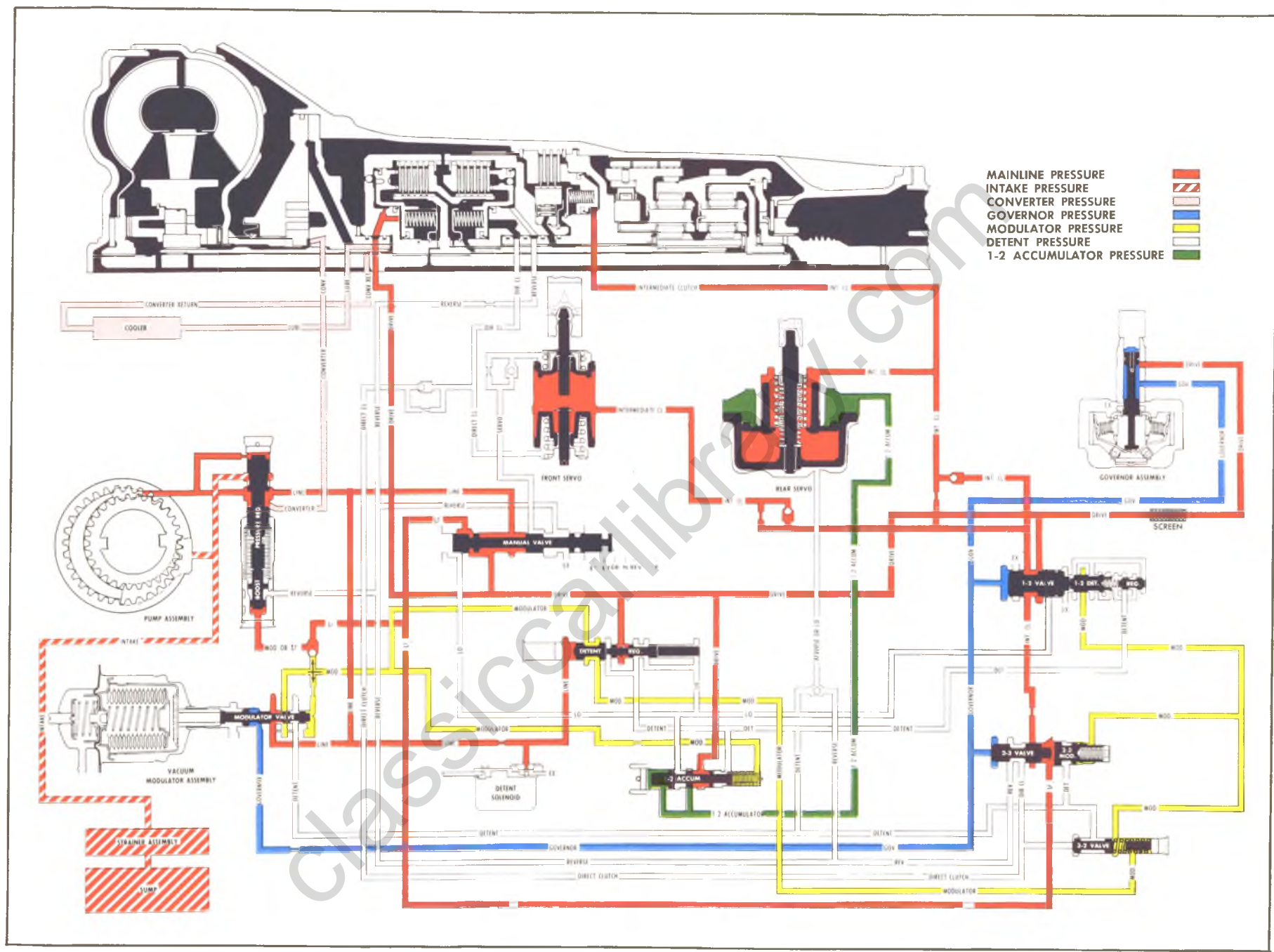

Fig. 23T-L2 Range Second Gear (Valves in Second Gear Position) Typical

**L2 RANGE-SECOND GEAR****(Valves in Second Gear Position)****Power Flow**

Forward Clutch - On

Low Roller Clutch - Ineffective

Direct Clutch - Off

Front Band - On

Rear Band - Off

Intermediate Clutch - On

Intermediate Roller Clutch - Effective

Detent Solenoid - De-energized

In second gear, the intermediate clutch is applied to allow the intermediate roller clutch to hold the sun gear against counterclockwise rotation. Turbine torque, through the forward clutch, is now applied through the mainshaft to the rear internal gear in a clockwise direction.

Clockwise rotation of the rear internal gear turns the rear pinions clockwise against the stationary sun gear. This causes the output carrier and output shaft to turn clockwise in a reduction ratio of approximately 1.5:1.

In second gear, engine braking is provided by the front

band as it holds the sun gear fixed. Without the band applied while coasting, the sun gear would overrun the intermediate roller clutch.

**Oil Flow**

When the selector lever is in L2, intermediate oil from the manual valve is directed to the:

1. Pressure Boost Valve
2. 2-3 Shift Valve

Intermediate oil at the boost valve will increase line pressure to 150 psi. This increased intermediate oil pressure at the 2-3 shift valve will close the 2-3 shift valve, regardless of car speed.

For engine braking, the front band is applied by exhausting servo oil at the manual valve. This allows intermediate clutch oil, acting on the servo piston, to move the piston and apply the front band. Once the transmission is in second gear-L2, it cannot upshift to third gear regardless of vehicle speed.

**Summary**

The forward and intermediate clutches and front band are applied. The transmission is in second gear - L2 Range.

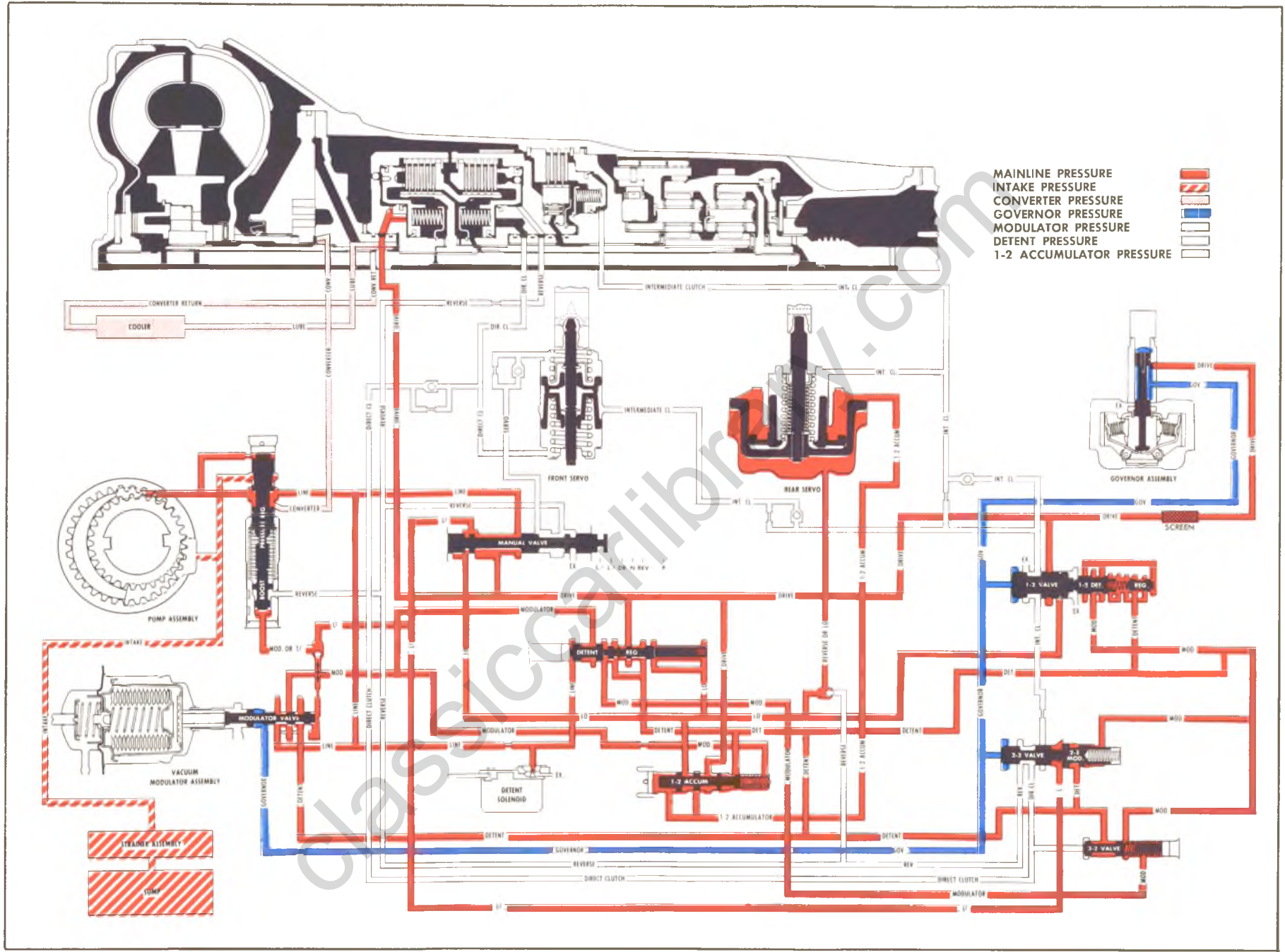

Fig. 24T-L1 Range - First Gear (Valves in First Gear Position) Typical



**L1 RANGE-FIRST GEAR****(Valves in First Gear Position)****Power Flow**

Forward Clutch - On

Low Roller Clutch - Effective

Direct Clutch - Off

Front Band - Off

Rear Band - On

Intermediate Clutch - Off

Intermediate Roller Clutch - Ineffective

Detent Solenoid - De-energized

With the selector lever in L1 range, the forward clutch is applied. This delevers turbine torque to the mainshaft and turns the rear internal gear in a clockwise direction (Converter torque ratio equals approximately 2.00:1 at stall).

Clockwise motion of the rear internal gear causes the rear pinions to turn clockwise to drive the sun gear counterclockwise. In turn, the sun gear drives the front pinions clockwise, thus turning the front internal gear, output carrier and output shaft clockwise in a reduction ration of approximately 2.5:1. The reaction of the front pinions against the front internal gear is taken by the reaction carrier and roller clutch to the transmission case (Total stall ratio equals approximately 5.00:1).

Down hill or overrun braking is provided in L1 range by applying the rear band as this prevents the reaction carrier from overrunning the roller clutch.

**Oil Flow**

Maximum downhill braking can be attained at speeds below 40 mph with the selector lever in L1 range, as this directs L1 oil from the manual valve to the:

1. Rear Servo
2. 1-2 Accumulator Valve
3. Detent Regulator Valve
4. 1-2 Shift Valve

**Basic Control**

L1 oil flows past a ball check to the apply side of the rear servo piston and to the 1-2 accumulator valve to raise the 1-2 accumulator oil to line pressure for a smooth band apply.

L1 oil acts on the detent regulator valve. Combined with the detent spring, L1 oil holds the detent valve against line oil acting on the detent valve, causing drive oil to flow through the detent regulator valve into the detent and modulator passages. Modulator and detent oil at line pressure, acting on the 1-2 regulator and 1-2 detent valve, overcomes governor oil and L1 oil on the 1-2 shift valve at any vehicle speed below approximately 40 mph and the transmission will shift to first gear.

In first gear - L1 range, the transmission cannot upshift to second gear regardless of vehicle or engine speed.

**Summary**

The forward clutch and rear band are applied. The transmission is in first gear - L1 Range.

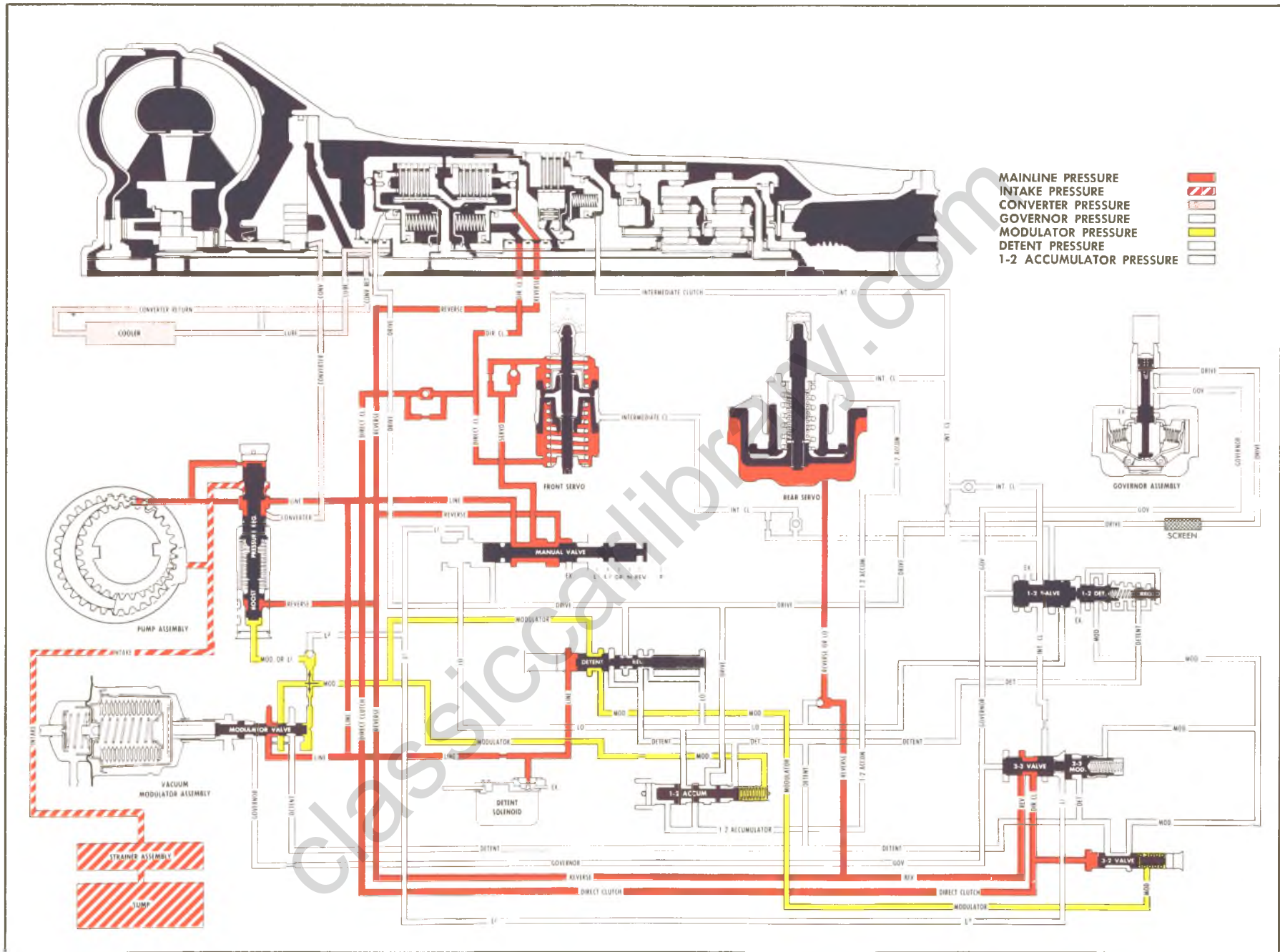

Fig. 25T—Reverse Range - Reverse Gear Typical

**REVERSE RANGE-REVERSE GEAR****Power Flow**

Forward Clutch - Off  
 Low Roller Clutch - Ineffective  
 Direct Clutch - On  
 Front Band - Off  
 Rear Band - On  
 Intermediate Clutch - Off  
 Intermediate Roller Clutch - Ineffective  
 Detent Solenoid - De-energized

In reverse gear, the direct clutch is applied to transmit turbine torque from the forward clutch drum to the sun gear shaft and sun gear. The rear band is also applied, preventing the reaction carrier from turning clockwise.

Clockwise torque to the sun gear causes the front pinions and front internal gear to turn counterclockwise in reduction. The front internal gear is connected directly to the output shaft, thus providing the reverse output gear ratio of approximately 2.00:1. The reverse torque multiplication at stall (converter and gear ratios) is approximately 4.00:1.

**Oil Flow**

When the selector lever is moved to the Reverse position, the manual valve is repositioned to allow line pressure to enter the reverse circuit. Reverse oil then flows to the:

1. Direct Clutch
2. 2-3 Shift Valve
3. Rear Servo Piston
4. Pressure Boost Valve

**Basic Control**

Reverse oil from the manual valve flows to the large area of the direct clutch piston and to the 2-3 shift valve. From the 2-3 shift valve, it enters the direct clutch passage and is directed to the small area of the direct clutch piston to apply the direct clutch.

Reverse oil flows to the rear servo and acts on the servo piston to apply the rear band. Reverse oil also acts on the pressure boost valve to boost line pressure.

**Summary**

The direct clutch and the rear band are applied. The transmission is in Reverse.

## MAINTENANCE AND ADJUSTMENTS

### CHECKING TRANSMISSION MOUNT

Raise the car on a hoist. Push up and pull down on the transmission tailshaft while observing the transmission mount. If the rubber separates from the metal plate of the mount or if the tailshaft moves up but not down (mount bottomed out), replace the mount. If there is relative movement between a metal plate of the mount and its attaching point, tighten the screws or nuts attaching the mount to the transmission or crossmember.

### TRANSMISSION FLUID

#### Fluid Level and Capacity

The fluid level indicator is located in the filler tube at the right rear of the engine. To bring the fluid level from the ADD mark to the FULL mark requires one pint of fluid. Fluid level should be checked at every engine oil change.

Fluid level should be to the FULL mark with the transmission fluid at normal operating temperature (180° F). With warm fluid (room temperature 70°F), the level will be 3/8 inch below the ADD mark on the dipstick. The normal operating temperature is obtained only after at least 15 miles of highway type driving or the equivalent of city driving.

Approximately 9 pints of fluid are required to refill transmission after oil pan has been drained. The fluid capacity of the Turbo Hydra-matic 400/475 transmission and converter assembly is approximately 22 pints but correct level is determined by mark on the dipstick rather than by amount added. Use only DEXRON® or DEXRON® II automatic transmission fluid or its equivalent.

**NOTE:** An early stage to a darker color from the usual red color and/or a strong odor that is usually associated with overheated transmission fluid is normal, and is not a positive sign of required maintenance or transmission failure.

#### Checking Procedure and Adding Fluid

To determine proper fluid level at normal operating temperature (180° F), proceed as follows:

1. Position vehicle on a level surface, place selector lever in park (P), apply parking brake and have engine running at normal idle.
2. Remove fluid level indicator, wipe it clean and reinstall fully until cap seats.
3. Remove indicator and reading of fluid level should be at full "F" mark.
4. If additional fluid is required, add DEXRON® or DEXRON® II automatic transmission fluid or its equivalent to "F" mark on indicator.

If the vehicle cannot be driven sufficiently to bring the transmission to operating temperature and it becomes necessary to check the fluid level, the transmission may

be checked at room temperature (70 degrees F) as follows:

1. Position selector lever in park (P), apply parking brake and start engine. **DO NOT RACE ENGINE.** Move selector lever through each range.
2. Immediately check fluid level with selector lever in Park, engine running and vehicle on LEVEL surface.

Fluid level on indicator should be 3/8 inch below the "ADD" mark.

3. If additional fluid is required, add enough fluid to bring level to 3/8 inch below the ADD mark on the dipstick. If transmission fluid level is correctly established at 70°F, it will appear at the FULL mark on the dipstick when the transmission reaches its normal operating temperature of 180°F.

**CAUTION:** *DO NOT OVERFILL, as foaming and loss of fluid through the vent pipe might occur as fluid heats up.*

If fluid is too low, especially when cold, complete loss of drive may result which can cause transmission failure.

#### Draining and Refilling Transmission

The oil pan should be drained and filter replaced every 24,000 miles and fresh fluid added to obtain the proper level on indicator. For vehicles subjected to heavy city traffic during hot weather, or in commercial use, when the engine is regularly idled for prolonged periods or when vehicle is used for towing, oil pan should be drained and filter replaced every 12,000 miles.

Drain fluid immediately after operation before it has had an opportunity to cool.

**WARNING:** Transmission fluid temperature can exceed 350°F.

1. Raise vehicle and support transmission with suitable jack at transmission.
2. With fluid receptacle placed under transmission oil pan, remove oil pan attaching bolts from front and side of pan.
3. Loosen rear pan attaching bolts approximately four (4) turns.
4. Carefully pry transmission oil pan loose with screwdriver, allowing fluid to drain.
5. Remove remaining screws and remove oil pan and gasket. Discard gasket.
6. Drain fluid from oil pan. Clean pan with solvent and dry thoroughly with clean compressed air.
7. Remove oil filter retainer bolt, oil filter assembly, O-ring seal from intake pipe and discard the filter and O-ring seal.
8. Install new O-ring seal on intake pipe and install new filter on pipe assembly.

9. With O-ring seal on intake pipe, install pipe and filter assembly, attaching filter to the control valve assembly with its retainer bolt, torquing to 10 pound feet.
10. Install new strainer-to-valve body gasket, strainer and two (2) screws.
11. Install new gasket on oil pan and install oil pan. Tighten its thirteen (13) attaching bolt and washer assemblies to 12 pound-feet.
12. Lower vehicle add approximately 5 pints U.S. measure (4 pints Imperial measure) of DEXRON® or DEXRON®II automatic transmission fluid or its equivalent through filler tube.
13. With selector lever in PARK position, apply hand brake, start engine and let idle (carburetor off fast idle step). DO NOT RACE ENGINE.
14. Move selector lever through each range and, with selector lever in PARK range, check the fluid level.
15. Add additional fluid to bring level to 1/4" below the ADD mark on the dipstick.

**CAUTION:** Do not overfill. Foaming will result if overfull.

**Adding Fluid to Fill Dry Transmission and Converter Assembly**

In cases of transmission overhaul, when a complete fill is required, including converter (approximately 22 pints), proceed as follows:

1. Add 9 pints of transmission fluid through filler tube.
2. With manual control lever in park (P) position,

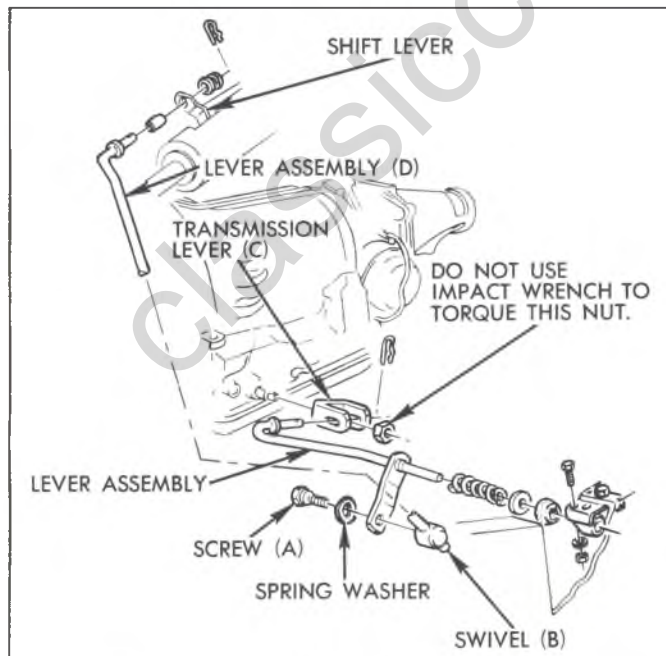

Fig. 26T—Column Shift Linkage - CK Series

start engine and place on cold idle cam. DO NOT RACE ENGINE. Move manual control lever through each range.

3. Immediately check fluid level with selector lever in park (P), engine running and vehicle on LEVEL surface and add additional fluid to bring level to 3/8-inch below the "ADD" mark on the dipstick. Do not overfill.

**SHIFT CONTROLS**

**Column Shift Linkage - CK and P Series (Figs. 26T and 27T)**

1. The shift tube and lever assembly must be free in the mast jacket. See Section 9 for alignment of steering column assembly if necessary.
2. To check for proper shift linkage adjustment, lift the transmission selector lever towards the steering wheel. Allow the selector lever to be positioned in drive (D) by the transmission detent.

**NOTE:** Do not use indicator pointer as a reference to position the selector lever. When performing linkage adjustment, pointer is adjusted last.

3. Release the selector lever. The lever should be inhibited from engaging low range unless the lever is lifted.
4. Lift the selector lever towards the steering wheel and allow the lever to be positioned in neutral (N) by the transmission detent.
5. Release the selector lever. The lever should now be inhibited from engaging reverse range unless the lever is lifted.
6. A properly adjusted linkage will prevent the selector from moving beyond both the neutral detent, and the drive detent unless the lever is lifted to pass over the mechanical stop in the steering column.
7. If adjustment is required, remove screw (A) and spring washer from swivel (B).
8. Set transmission lever (C) in Neutral position by moving lever counter-clockwise to L1 detent and then clockwise three (3) detent positions to Neutral.
9. Position transmission selector lever in Neutral position as determined by the mechanical stop in steering column assembly.

**NOTE:** Do not use the indicator pointer as a reference to position the selector lever. When performing linkage adjustment, pointer is adjusted last.

10. Assemble swivel, spring washer and screw to lever assembly (D) and tighten screw to 20 pound feet.
11. Readjust indicator needle if necessary to agree with the transmission detent positions. See Section 9.

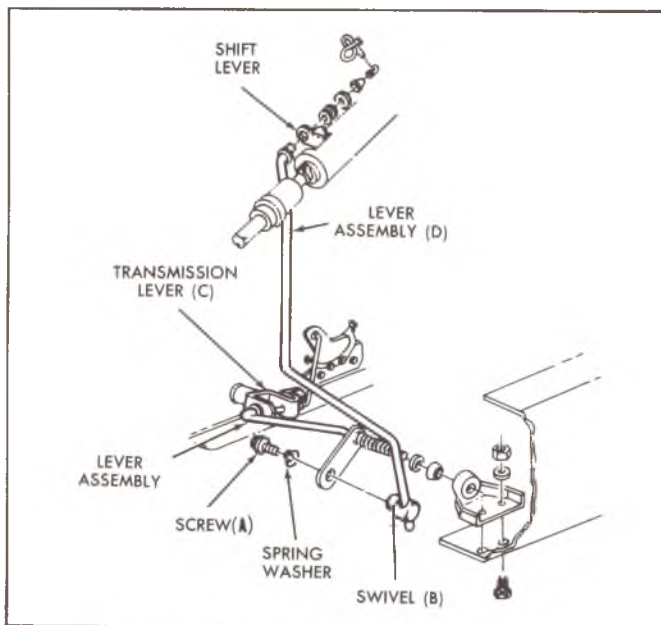

Fig. 27T—Column Shift Linkage - P Series

12. Readjust neutral start switch if necessary to provide the correct relationship to the transmission detent positions. See Section 12.
13. Check operation (CK Series):
  - a. With key in "Run" position and transmission in "Reverse" be sure that key cannot be removed and that steering wheel is not locked.
  - b. With key in "Lock" position and shift lever in "Park", be sure that key can be removed, that steering wheel is locked, and that transmission remains in "Park" when steering column is locked.

**CAUTION:** Any inaccuracies in the above adjustments may result in premature failure of the transmission due to operation without controls in full detent. Such operation results in reduced oil pressure and in turn partial engagement of the affected clutches. Partial engagement of the clutches with sufficient pressure to cause apparent normal operation of the vehicle will result in failure of the clutches or other internal parts after only a few miles of operation.

## DETENT DOWNSHIFT SWITCH

1. Install switch as shown in Figure 28T.
2. After installing the switch, press the switch plunger as far forward as possible. This presets the switch for adjustment. The switch will then adjust itself with the first wide open throttle application of the accelerator pedal.

## NEUTRAL START BACKUP LAMP SWITCH ADJUSTMENT

The neutral start backup lamp switch must be adjusted so that the car will start in the park or neutral position, but will not start in the other positions. For replacement and adjustment refer to Section 12 of this manual.

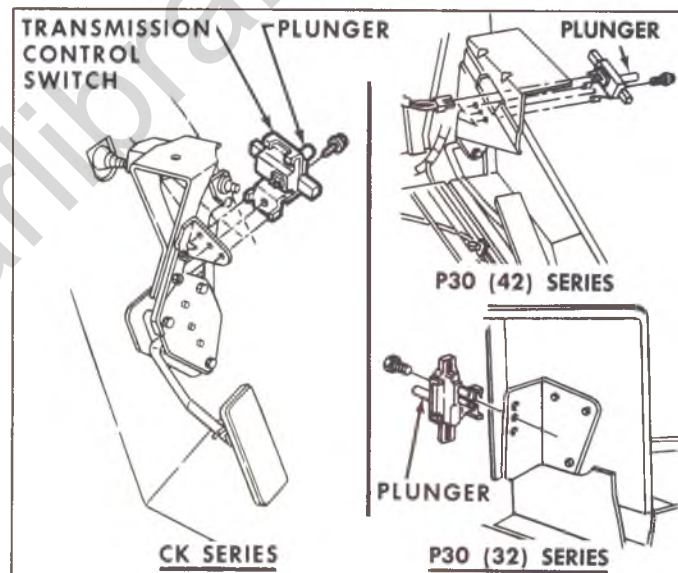

Fig. 28T—Detent Downshift Switch

## SERVICE OPERATIONS

### PRESSURE REGULATOR VALVE

#### Removal

1. Remove bottom pan and filter.
2. Compress regulator boost valve bushing against pressure regulator spring and remove snap ring, using J-5403 pliers.
3. Remove regulator boost valve bushing and valve.
4. Remove pressure regulator spring.
5. Remove spring retainer, washer spacer(s) is present, and regulator valve.

#### Installation

**NOTE:** A solid type pressure regulator valve must only be used in a pump cover with a squared-off pressure regulator boss (See Figure 29T). A pressure regulator valve with oil holes and orifice cup plug may be used to service either type pump.

Installation of the pressure regulator valve is the reverse of the removal. Installing new gasket on oil pan and adjusting fluid level.

### CONTROL VALVE BODY

#### Removal

1. Remove bottom pan and filter.
2. Disconnect lead wire from pressure switch assembly.
3. Remove control valve body attaching screws and detent roller spring assembly.

**NOTE:** Do not remove solenoid attaching screws.

**CAUTION:** If the transmission is in the vehicle, the front servo parts may drop out as the control valve assembly is removed.

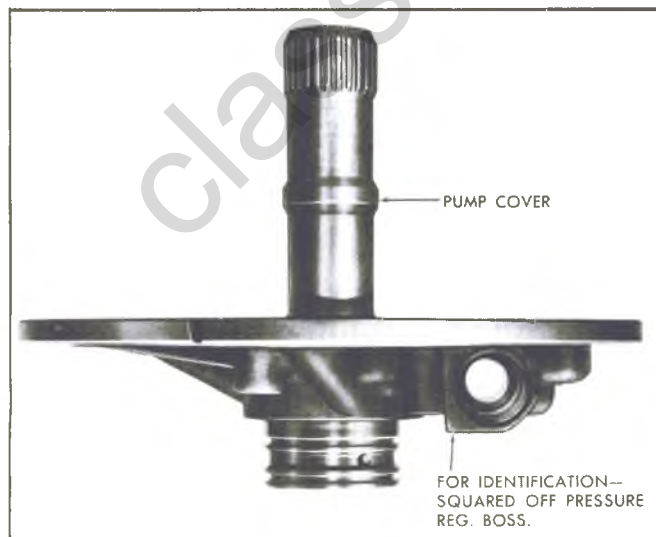

Fig. 29T—Pressure Regulator Valve

4. Remove control valve body assembly and governor pipes. If care is taken in removing control valve body the six (6) check balls will stay in place above the spacer plate.
5. Remove the governor screen assembly from end of governor feed pipe or from the governor feed pipe hole in the case (fig. 30T). Clean governor screen in clean solvent and air dry.

**CAUTION:** Do not drop manual valve.

6. Remove the governor pipes and manual valve from control valve body.

#### Installation

Installation of control valve body is in reverse of removal. See Overhaul Manual. Adjust fluid level.

### GOVERNOR

#### Removal

1. Remove governor cover attaching screws, cover, and gasket.
2. Discard gasket.
3. Withdraw governor assembly from case.

#### Installation

Installation of the governor assembly is the reverse of the removal. Use a new gasket under the governor cover. Adjust fluid level.

### MODULATOR AND MODULATOR VALVE

#### Removal

1. Remove modulator assembly attaching screw and retainer.
2. Remove modulator assembly from case. Discard "O" ring seal.
3. Remove modulator valve from case.

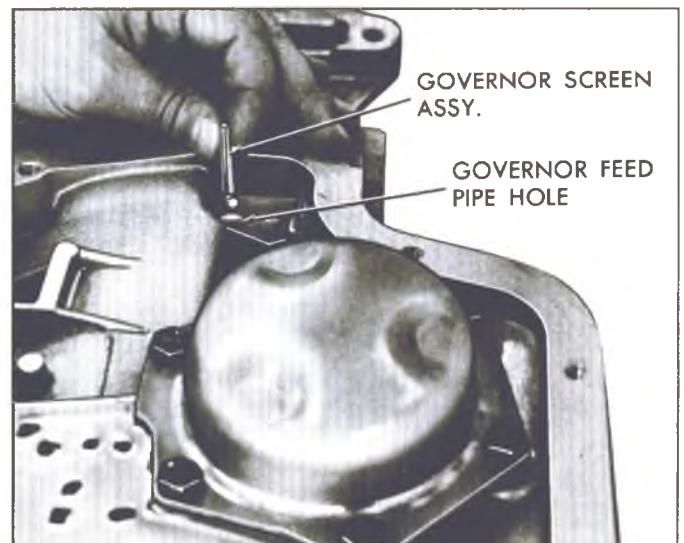

Fig. 30T—Governor Screen Position

## 7A-76 AUTOMATIC TRANSMISSION

### Installation

Installation of the modulator assembly and modulator valve is the reverse of the removal. Use a new "O" ring seal on the modulator assembly.

Adjust fluid level.

## PARKING LINKAGE—10, 20 SERIES

### Removal

1. Remove bottom pan and oil filter.
2. Unthread jam nut holding detent lever to manual shaft.
3. Remove manual shaft retaining pin from case.
4. Remove manual shaft and jam nut from case.

NOTE: Do not remove manual shaft seal unless replacement is required.

5. Remove parking actuator rod and detent lever assembly.
6. Remove parking pawl bracket attaching screws and bracket.
7. Remove parking pawl return spring.

NOTE: The following steps should be completed unless part replacement is required.

8. Remove parking pawl shaft retainer.
9. Remove parking pawl shaft, cup plug parking pawl shaft, and parking pawl.

### Installation

Installation of the parking linkage is the reverse of the removal. Use new seal and cup plug, if removed, and new bottom pan gasket.

## REAR SEAL

### Removal

1. Remove propeller shaft.
2. Pry seal out with screw driver.

### Installation

#### All Models Except CM

1. Use a non-hardening sealer on outside of seal body; and using Tool J-2139, drive seal in place.
2. Re-install propeller shaft.

#### Model CM

1. Use a non-hardening sealer on outside of seal body; and using Tool J-21464, drive seal in place.
2. Re-install propeller shaft.

## OTHER SERVICE OPERATIONS

The following operations when done as single operations and not as part of a general overhaul should, as a

practical matter, be performed with the transmission in the vehicle. Refer to the "Transmission Disassembly and Reassembly" section of the Overhaul Manual for service procedures.

1. Oil filler pipe and "O" ring seal.
2. Oil pan and gasket.
3. Down shift solenoid or connector.
4. Valve body spacer plate, gasket and check balls.
5. Front accumulator piston.
6. Rear servo and rear accumulator assembly.
7. Rear band apply checking with Tool J-21370.
8. Front servo assembly.
9. Speedo driven gear.
10. Case extension or gasket.
11. Filter and "O" ring.
12. Pressure switch assembly.

## TRANSMISSION REPLACEMENT

### Removal

Before raising the truck, disconnect the battery and release the parking brake.

1. Raise truck on hoist.
2. Remove propeller shaft.
3. Disconnect speedometer cable, electrical lead to case connector, vacuum line at modulator, and oil cooler pipes.
4. Disconnect shift control linkage.
5. Support transmission with suitable transmission jack.
6. Disconnect rear mount from frame crossmember.
7. Remove two bolts at each end of the frame crossmember and remove crossmember.
8. Remove converter under pan.
9. Remove converter to flywheel bolts.
10. Loosen exhaust pipe to manifold bolts approximately 1/4 inch, and lower transmission until jack is barely supporting it.
11. Remove transmission to engine mounting bolts and remove oil filler tube at transmission.
12. Raise transmission to its normal position, support engine with jack and slide transmission rearward from engine and lower it away from vehicle.
13. Use converter holding Tool J-5384 when lowering transmission or keep rear of transmission lower than front so as not to lose converter.

### Installation

The installation of the transmission is the reverse of the removal with the following additional steps.



1. Before installing the flex plate to converter bolts, make certain with the flex plate that the weld nuts on the converter as flush with the flex plate and the converter rotates freely by hand in this position. Then, hand start all bolts and tighten finger tight before torquing to specification. This will insure proper converter alignment.
2. Install transmission support crossmember to transmission and frame with taper on support sloping toward rear.
3. After installation of transmission, check linkage for proper adjustment.

4. Remove truck from hoist.

### OIL COOLER PIPES

If replacement of transmission steel tubing cooler pipes is required, use only double wrapped and brazed steel tubing meeting GM specification 123M or its equivalent. Under no condition use copper or aluminum tubing to replace steel tubing. Those materials do not have satisfactory fatigue durability to withstand normal vehicle vibrations.

Steel tubing should be flared using the upset (double lap) flare method which is detailed in Section 5.

## DIAGNOSIS

### SEQUENCE FOR DIAGNOSIS

1. Check and correct oil level.
2. Check detent switch.
3. Check and correct vacuum line and fittings.
4. Check and correct manual linkage.
5. Install oil pressure gage.
6. Road test car.
  - a. Road test using all selective ranges, noting when discrepancies in operation or oil pressure occur.
  - b. Attempt to isolate the unit or circuit involved in the malfunction.
  - c. If engine performance indicates an engine tune up is required, this should be performed before road testing is completed or transmission correction attempted. Poor engine performance can result in rough shifting or other malfunctions.

### FLUID CHECKING PROCEDURES

Refer to Maintenance and Adjustment section for fluid checking procedure.

### FLUID LEAK DIAGNOSIS

#### Determining Source of Oil Leak

Before attempting to correct an oil leak, the actual source of the leak must be determined. In many cases, the source of the leak can be deceiving due to "wind flow"

around the engine and transmission.

The suspected area should be wiped clean of all oil before inspecting for the source of the leak. Red dye is used in the transmission oil at the assembly plant and will indicate if the oil leak is from the transmission.

The use of a "Black Light" to locate the point at which the oil is leaking is helpful. Comparing the oil from the leak to that on the engine or transmission dipstick, when viewed by black light, will determine the source of the leak - engine or transmission.

Oil leaks around the engine and transmission are generally carried toward the rear of the car by the air stream. For example, a transmission oil fill pipe to case leak will sometimes appear as a leak at the rear of the transmission. In determining the source of a leak, proceed as follows:

1. Degrease underside of transmission.
2. Road test to get unit at operating temperature. (180 degrees F.)
3. Inspect for leak with engine running.
4. With engine off, check for oil leaks due to the raised oil level caused by drain back.

#### Possible Points of Oil Leak

1. Transmission Oil Pan Leak
  - a. Attaching bolts not correctly torqued.
  - b. Improperly installed or damaged pan gasket.
  - c. Oil pan gasket mounting face not flat.
2. Case Extension

## 7A-78 AUTOMATIC TRANSMISSION

- a. Attaching bolts not correctly torqued.
  - b. Rear seal assembly damaged or improperly installed.
  - c. Extension to case, gasket damage or improperly installed.
  - d. Porous casting. See paragraph C.
  - e. Output shaft "O" ring damaged.
3. Case Leak
- a. Filler pipe "O" ring seal damaged or missing; misposition of filler pipe bracket to engine "loading" one side of "O" ring.
  - b. Modulator assembly "O" ring seal damaged or improperly installed.
  - c. Electrical connector "O" ring seal damaged or improperly installed.
  - d. Governor cover bolts not torqued, gasket damaged or leak between case face and gasket.
  - e. Speedometer gear "O" ring damaged.
  - f. Manual shaft lip seal damaged or improperly installed.
  - g. Parking pawl shaft cup plug damaged, improperly installed.
  - h. Line pressure band release tap plug loose.
  - i. Vent pipe (refer to item 5).
  - j. Porous casting. See subparagraph C.
4. Leak at Front of Transmission
- a. Front pump seal leaks.
    1. Seal lip cut. Check converter hub for nicks, etc.
    2. Bushing moved forward and damaged.
    3. Garter spring missing from seal.
  - b. Front pump attaching bolts loose or bolt seals damaged or missing.
  - c. Front pump housing "O" ring damaged or cut.
  - d. Converter leak in weld area.
  - e. Porous casting (pump).
5. Oil Comes Out Vent Pipe
- a. Transmission over-filled.
  - b. Water in oil.
  - c. Foreign matter between pump and case or between pump cover and body.
  - d. Case - porous, front pump cover mounting face shy of stock near breather. See subparagraph C.
  - e. Pump to case gasket mispositioned.
  - f. Incorrect dipstick.
  - g. Cut "O" ring or grommet on filter.
  - h. Pump - shy of stock on mounting faces, porous casting, breather hole plugged in pump cover.

## OIL PRESSURE CHECK

### Road or Normal Operating Conditions

While road testing (with the transmission oil pressure gage attached and the vacuum modulator tube connected, the transmission pressure should check approximately as shown on figure 31T.

### Vehicle Stationary - Engine at 1200 RPM

With the transmission oil pressure gauge attached and the vacuum modulator tube disconnected, the transmission pressures should check approximately as shown in Fig. 32T.

### Vehicle Stationary - Engine at 1000 RPM

With the transmission oil pressure gauge attached and the vacuum modulator tube connected for normal modulator operation, the transmission pressure should check approximately as shown in Fig. 33T.

NOTE: Pressures are not significantly affected by altitude or barometric pressure when the vacuum modulator tube is connected.

## Case Porosity Repair

External leaks caused by case porosity have successfully been repaired with the transmission in the vehicle by using the following recommended procedures:

1. Road test and bring the transmission to operating temperature, approximately 180 degrees.
2. Raise vehicle on hoist or jack stand, engine running and locate source of oil leak. Check for leak in all operating positions. Use of a mirror is helpful in finding leaks.
3. Shut engine off and thoroughly clean area to be repaired with a cleaning solvent and a brush air dry.
4. Using instructions of the manufacturer, mix a sufficient amount of epoxy, Part No. 1360016, or equivalent to make repair. Observe cautions of mfg. in handling.
5. While the transmission case is still HOT apply the epoxy to the area to be repaired. A clean, dry soldering acid brush can be used to clean the area and also to apply the epoxy cement. Make certain the area to be repaired is fully covered.
6. Allow cement to cure for three hours before starting engine.
7. Road test and check for leaks.

## VACUUM MODULATOR DIAGNOSIS

A defective vacuum modulator can be determined by performing the following procedures.

### Vacuum Diaphragm Leak Check

Insert a pipe cleaner into the vacuum connector pipe as

		<u>Minimum</u>	<u>Maximum</u>
L2-2nd Gear - Steady road load at approximately 25 mph		145 psi	155 psi
<u>Gear</u>	<u>Selector Lever Position</u>	<u>Minimum</u>	<u>Maximum</u>
1st	Drive		
2nd	("Zero" throttle to full throttle. . . . .)	60	150
3rd			
3rd	Drive Range, Zero Throttle at 30 mph . . . . .	60	
Reverse	Rev. (Zero to full throttle . . . . .)	95	260

Fig. 31T—Oil Pressure Check - Road or Normal Operating Conditions

Approximate Altitude of Check (Ft. above sea level)	Drive Neutral Park	L1 or L2	Reverse
0	150	150	244
2,000	150	150	233
4,000	145	150	222
6,000	138	150	212
8,000	132	150	203
10,000	126	150	194
12,000	121	150	186
14,000	116	150	178

Fig. 32T—Oil Pressure Check - Vehicle Stationary, Vacuum Tube Disconnected

<u>Drive, Neutral, Park</u>	<u>L1 or L2</u>	<u>Reverse</u>
60	150	107

Fig. 33T—Oil Pressure Check - Vehicle Stationary, Vacuum Tube Connected

far as possible and check for the presence of transmission oil. If oil is found, replace the modulator.

Gasoline or water vapor may settle in the vacuum side of the modulator. If this is found without the presence of oil, the modulator should not be changed.

**Atmospheric Leak Check**

Apply a liberal coating of soap bubble solution to the vacuum connector pipe seam, the crimped upper to lower housing seam, and the threaded screw seal (Fig. 34T). Using a short piece of rubber tubing apply air pressure to the vacuum pipe by blowing into the tube and observe for leak bubbles. If bubbles appear, replace the modulator.

NOTE: Do not use any method other than human lung power for applying air pressure, as pressures over 6 psi may damage the modulator.

**Bellows Comparison Check**

Using a comparison gauge, as shown in Figure 35T, compare the load of a known good Hydra-Matic modulator with the assembly in question.

- a. Install the modulator that is known to be acceptable on either end of the gauge (Fig. 36T).

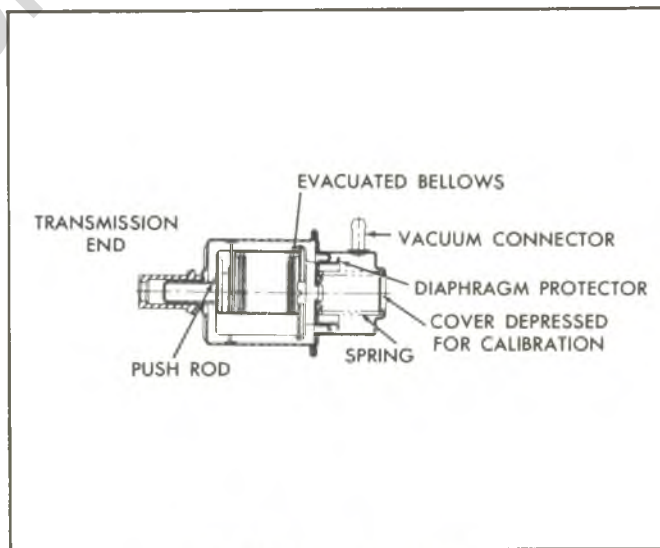

Fig. 34T—Vacuum Modulator

- b. Install the modulator in question on the opposite end of the gauge. (Fig. 37T).
- c. Holding the modulators in a horizontal position, bring them together under pressure until either modulator sleeve end just touches the line in the center of the gauge (Fig. 38T). The gap between the opposite modulator sleeve end and the gauge line should then be 1/16" or less. If the distance is greater than this amount, the modulator in question should be replaced.

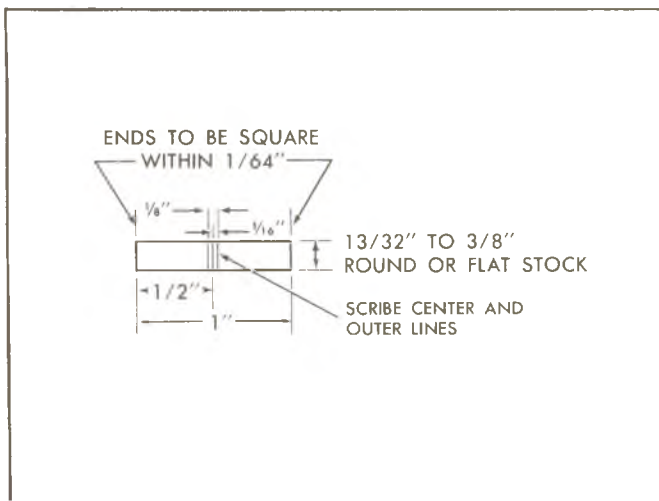

Fig. 35T—Bellows Comparison Gauge

### Sleeve Alignment Check

Roll the main body of the modulator on a flat surface and observe the sleeve for concentricity to the can. If the sleeve is concentric and the plunger is free, the modulator is acceptable.

Once the modulator assembly passes all of the above tests, it is an acceptable part and should be re-used.

### MANUAL LINKAGE

Manual linkage adjustment and the associated neutral safety switch are important from a safety standpoint. The neutral safety switch should be adjusted so that the engine will start in the Park and Neutral positions only.

With the selector lever in the Park position, the parking pawl should freely engage and prevent the vehicle from rolling. The pointer on the indicator quadrant should line up properly with the range indicators in all ranges.

### TROUBLE DIAGNOSIS

#### No Drive in Drive Range

(Install pressure gage)

- Low oil level - check for external leaks or defective vacuum modulator (leaking diaphragm will evacuate oil from unit).
- Manual linkage maladjusted (correct alignment in manual lever shift quadrant is essential); manual valve disconnected from manual lever pin.
- Low oil pressure - refer to **LOW LINE PRESSURE** below.
- Forward clutch:
  - a. Clutch does not apply - piston cracked; seals missing, damaged; clutch plates burnt (see **BURNED CLUTCH PLATES** below).
  - b. Pump feed circuit-to-forward clutch oil seal rings missing or broken on pump cover; leak or restriction in feed circuits; pump-to-case gasket

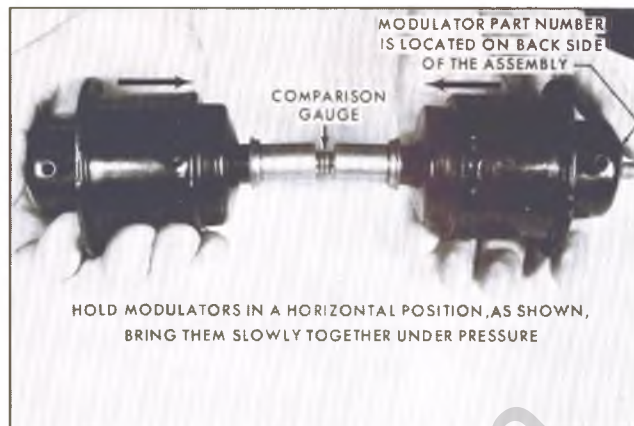

Fig. 36T—Holding Modulators in Horizontal Position

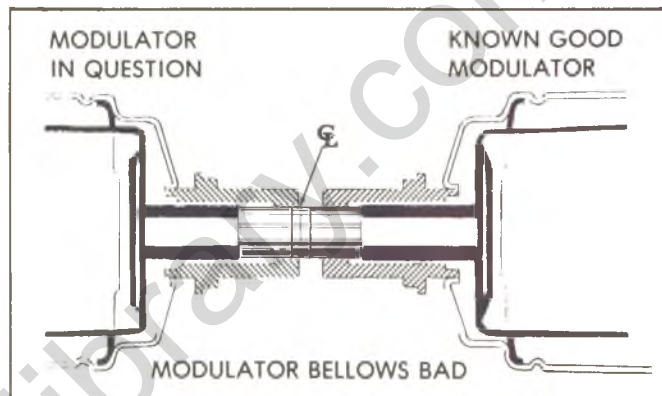

Fig. 37T—Modulator Bellows - Bad

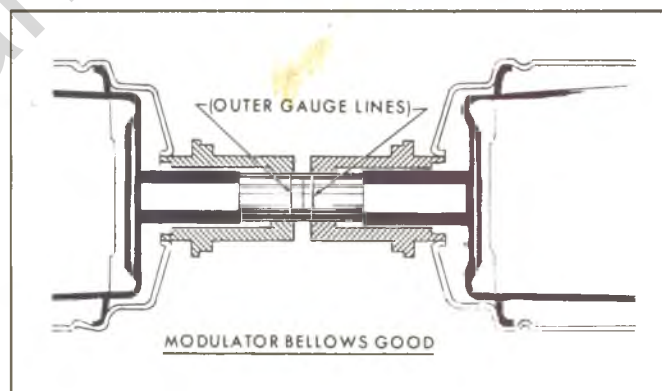

Fig. 38T—Modulator Bellows (Good)

mispositioned or damaged. Clutch drum ball check stuck or missing.

- Roller Clutch - broken springs, damaged cage or installed backwards.

#### High or Low Oil Pressure

(Refer to **OIL PRESSURE CHECKS**)

##### High Line Pressure

- Vacuum Leak:
  - a. Vacuum line disconnected.

- b. Leak on line from engine to modulator.
- c. Improper engine vacuum.
- d. Leak in vacuum-operated accessory (hoses, vacuum advance, etc.).
- Modulator:
  - a. Stuck modulator valve.
  - b. Water in modulator.
  - c. Damaged, not operating properly.
- Detent System:
  - a. Detent switch actuated (plunger stuck) or shorted.
  - b. Detent wiring shorted.
  - c. Detent solenoid stuck open.
  - d. Detent feed orifice in spacer plate blocked or restricted.
  - e. Detent solenoid loose.
  - f. Detent valve bore plug damaged.
  - g. Detent regulator valve pin short.
- Oil Pump:
  - a. Pressure regulator and/or boost valve stuck.
  - b. Incorrect pressure regulator valve spring.
  - c. Too many pressure regulator valve spacers.
  - d. Pressure boost valve installed backwards or defective.
  - e. Pressure boost bushing broken or defective.
  - f. Pump casting bad.

**Low Line Pressure**

- Low transmission oil level.
- Defective vacuum modulator assembly.
- Filter Assembly:
  - a. Blocked or restricted.
  - b. "O" Ring seal on intake pipe and/or grommet omitted or damaged.
  - c. Split or leaking intake pipe.
  - d. Wrong filter assembly.
- Oil Pump:
  - a. Pressure regulator and/or boost valve stuck.
  - b. Pressure regulator valve spring too weak.
  - c. Not enough spacers in pressure regulator.
  - d. Gear clearance, damaged, worn, drive gear installed backwards.
  - e. Pump-to-case gasket mispositioned.
  - f. Defective or mismatched pump body/pump cover.
- Internal Circuit Leaks:
  - a. Forward clutch leak (pressure low in Drive

range - pressure normal in Neutral and Reverse).

1. Check pump oil seal rings.
  2. Check forward clutch seals.
- b. Direct clutch leak (pressure low in Reverse, pressure normal in all other ranges).
    1. Check center support oil seal rings.
    2. Check direct clutch outer seal.
    3. Check rear servo and front accumulator pistons and rings for damage or missing.
6. Case Assembly:
    - a. Porosity in intake bore area.
    - b. Check case for intermediate clutch cup plug leak or blown out.
    - c. L1-reverse check ball mispositioned or missing (this will cause no reverse and no overrun braking in L1 range).

**1-2 Shift-Full Throttle Only**

- Detent switch sticking or defective (may stick in cold or wet weather). Can be detected by pulling connection at transmission and obtaining normal upshifts.
- Detent solenoid:
  - a. Loose.
  - b. Gasket leaking.
  - c. Sticks open.
- Control valve:
  - a. Valve body gaskets - leaking, damaged, incorrectly installed.
  - b. Detent valve train stuck.
  - c. 3-2 valve stuck.
- Case - porosity.

**First Speed Only, No 1-2 Shift**

- Governor:
  - a. Valve sticking.
  - b. Driven gear loose, damaged or worn (check for pin in case and length of pin showing); also check output shaft drive gear for nicks or rough finish if driven gear shows damage.
- Control valve:
  - a. 1-2 shift valve train stuck closed.
  - b. Governor feed channels blocked, leaking, pipes out of position, governor screen plugged.
  - c. Valve body gaskets leaking, damaged, incorrectly installed.
- Case:
  - a. Intermediate clutch cup plug leaking or blown out.

## 7A-82 AUTOMATIC TRANSMISSION

- b. Porosity between channels.
- c. Governor feed channel blocked; governor bore scored or worn, allowing cross pressure leak.
- Intermediate clutch:
  - a. Case center support - oil rings missing, broken, defective; orifice plug missing.
  - b. Clutch piston seals missing, improperly assembled, cut.

### First and Second Speeds Only, No 2-3 Shift

- Detent solenoid - stuck open (detent shifts only - the 2-3 shift would occur at very high speeds, being interpreted as no 2-3 shift).
- Detent switch.
- Control valve:
  - a. 2-3 valve train stuck.
  - b. Valve body gaskets leaking, damaged, incorrectly installed.
- Direct clutch:
  - a. Center support oil rings missing, broken, defective.
  - b. Clutch piston seals missing, improperly assembled, cut; piston ball check stuck or missing.

### Drive in Neutral

- Manual linkage maladjusted.
- Internal Linkage:
  - a. Manual valve disconnected or end broken.
  - b. Inside detent lever pin broken.
- Pump Assembly - transmission lube pressure leaking into forward clutch apply passage.
- Forward Clutch:
  - a. Burned plates - check cause.
  - b. Clutch doesn't release - will also cause no drive in Reverse.

### No Drive in Reverse or Slips in Reverse

(Install pressure gauge)

- Low fluid level.
- Manual linkage maladjusted.
- Oil pressure - refer to LOW LINE PRESSURE above.
- Control valve:
  - a. Valve body gaskets leaking, damaged, incorrectly installed (Other malfunctions may also be indicated).
  - b. Low reverse ball check missing from case (this will also cause no overrun braking in L1 Range).

- c. 2-3 valve train stuck open (this will also cause 1-3 upshift in Drive range).
- d. Reverse feed passage restricted; also check case passages.
- Rear servo and accumulator:
  - a. Servo piston seal ring damaged or missing.
  - b. Short band apply pin (this may also cause no overrun braking or slips in overrun braking - L1 range). Refer to INSTALLATION OF REAR SERVO ASSEMBLY for pin selection procedure.
  - c. Defective rear servo piston or bore.
- Reverse or low band burnt, loose lining; apply pin or anchor pins not engaged; band broken.
- Direct clutch:
  - a. Outer seal damaged or missing.
  - b. Clutch plates burnt (see BURNED CLUTCH PLATES below).
- Forward clutch - clutch does not release (will also cause Drive in Neutral).
- Center support - oil seal rings or grooves damaged or worn.

### Slips in all Ranges, Slips on Start

(Install pressure gauge)

- Low fluid level.
- Oil pressure - refer to LOW LINE PRESSURE above.
- Case - cross leaks, porosity.
- Forward and direct clutches slipping (if burnt, see BURNED CLUTCH PLATE below); oil seal rings on pump cover broken or worn.

### Slips 1-2 Shift

(Install pressure gauge)

- Low fluid level.
- Oil pressure - refer to LOW LINE PRESSURE above.
- Front accumulator piston oil ring damaged or missing.
- Control valve:
  - a. 1-2 accumulator valve train sticking.
  - b. Porosity in valve body or case.
  - c. Valve body attaching bolts not properly torqued.
- Rear accumulator oil ring missing or damaged; case bore damaged.
- Pump-to-case gasket mispositioned.
- Case:
  - a. Intermediate clutch cup plug leaks excessively.
  - b. Porosity between channels.

- c. Raised ridge around case center support bolt (does not allow control valve assembly to seat properly).
- Intermediate clutch:
  - a. Piston seals missing or damaged; clutch plates burnt (see **BURNED CLUTCH PLATES** below).
  - b. Center support - leak in feed circuit (oil rings damaged or grooves defective), excessive leak between tower and bushing, orifice bleed plug hole (.020 dia.) blocked, center support bolt not seated properly in case.

### **Rough 1-2 Shift**

(Install pressure gauge)

- Oil pressure - refer to **HIGH LINE PRESSURE** above.
- Control valve:
  - a. 1-2 accumulator valve train.
  - b. Valve body-to-case bolts loose.
  - c. Wrong gaskets or off location, damaged.
- Case:
  - a. Intermediate clutch ball missing or not sealing.
  - b. Porosity between channels.
- Rear servo accumulator:
  - a. Oil rings damaged.
  - b. Piston stuck.
  - c. Broken or missing spring.
  - d. Bore damaged.
- Intermediate clutch - clutch plates burnt (see **BURNED CLUTCH PLATES** below).

### **Slips 2-3 Shift**

(Install pressure gauge)

- Low fluid level.
- Oil pressure - refer to **LOW LINE PRESSURE** above.
- Control valve - accumulator piston pin (leak at swedge end).
- Case porosity.
- Direct clutch:
  - a. Piston seals leaking or ball check leaks.
  - b. Center support oil seal rings damaged; excessive leak between tower and bushing.

### **Rough 2-3 Shift**

(Install pressure gauge)

- Oil Pressure - refer to **HIGH LINE PRESSURE** above.
- Front servo accumulator:

- a. Front accumulator spring missing, broken.
- b. Accumulator piston stuck.
- Direct clutch - air check for leak to outer area of clutch piston or center piston seal.
- Damaged center support.

### **No Engine Braking in L2 Range - 2nd Gear**

- Front servo accumulator:
  - a. Servo or accumulator oil rings or bores leaking.
  - b. Servo piston cocked or stuck.
- Front band broken, burnt (check for cause), not engaged on anchor pin and/or servo pin.

### **No Engine Braking in L1 Range - 1st Gear**

- Case assembly - L1-reverse check ball mispositioned or missing from case; case damaged at L1-reverse check ball area.
- Rear servo:
  - a. Oil seal ring, bore or piston damaged; leaking apply pressure.
  - b. Rear band apply pin short, improperly assembled.
- Rear band broken, burnt (check for cause), not engaged on anchor pins or servo pin.

NOTE: Items above will also cause slips in Reverse or no Reverse.

### **No Part Throttle Downshift**

(Install pressure gauge)

- Oil pressure - refer to **HIGH OR LOW OIL PRESSURE** above.
- Control valve - 3-2 valve stuck spring missing or broken.

### **No Detent Downshifts**

- Detent switch adjustments, connection (switch plunger activated approx. 7/8" at full throttle opening).
- Solenoid inoperative, connections.
- Control valve-detent valve train sticking.

### **Low or High Shift Points**

(Install pressure gauge)

- Oil Pressure - refer to **HIGH OR LOW OIL PRESSURE** above.
- Governor:
  - a. Valve sticking.
  - b. Feed holes restricted or leaking; pipes damaged or mispositioned.
  - c. Feed line screen plugged.
- Detent switch.

## 7A-84 AUTOMATIC TRANSMISSION

- Detent solenoid stuck open, loose, etc. (will cause late shifts).
- Control valve:
  - a. Detent valve train.
  - b. 3-2 valve train (detent upshifts possible).
  - c. 1-2 shift valve train - 1-2 regulator valve stuck (this would cause a constant 1-2 shift point, regardless of throttle opening).
  - d. Spacer plate gaskets mispositioned; spacer plate orifice holes missing or blocked.
- Case porosity; intermediate clutch cup plug leaking, missing.

### Won't Hold in Park

- Manual linkage maladjusted.
- Internal linkage:
  - a. Parking brake lever and actuator defective (check for chamfer on actuator rod sleeve).
  - b. Parking pawl broken.
  - c. Parking pawl bracket loose, burned, rough edges or incorrectly installed.
  - d. Parking pawl return spring missing, broken or incorrectly hooked.

### Transmission Noisy

**CAUTION:** Before checking transmission for what is believed to be "transmission noise", make sure that the noise is not from the water pump, alternator, power steering, etc. These components can be isolated by removing the proper belt and running the engine no more than two minutes at one time.

### Park, Neutral and all Driving Ranges

- Pump Cavitation:
  - a. Oil level low.
  - b. Plugged or restricted filter.
  - c. Intake pipe "O" ring damaged.
  - d. Intake pipe split, porosity in case intake pipe bore.
  - e. Water in oil.
  - f. Porosity or voids at transmission case (pump face) intake port.
  - g. Pump-to-case gasket off location.
- Pump Assembly:
  - a. Gears damaged or defective; driving gear installed backwards.
  - b. Crescent interference.
  - c. Oil seal rings damaged or worn.
- Converter:
  - a. Loose flywheel-to-converter bolts.

- b. Damaged converter.

### First, Second and/or Reverse Gears

#### Planetary Gear Set:

- a. Gears or thrust bearings damaged.
- b. Front internal gear ring damaged.

#### During Acceleration - Any Gear

- Transmission or cooler lines grounded to underbody.
- Motor mounts loose or broken.

### Squeal at Low Vehicle Speed

Speedometer driven gear shaft seal - requires lubrication or replacement.

### Burned Clutch Plates

- Forward clutch:
  - a. Check ball in clutch drum damaged, stuck or missing.
  - b. Clutch piston cracked, seals damaged or missing.
  - c. Low line pressure (see LOW LINE PRESSURE above).
  - d. Manual valve mispositioned (may also cause front band failure).
  - e. Restricted oil feed to forward clutch (clutch housing to inner and outer areas not drilled, restricted, porosity in pump, etc.).
  - f. Transmission case valve body face not flat or porosity between channels.
  - g. Manual valve bent and center land not ground properly.
  - h. Pump cover oil seal rings missing, broken or undersize, ring groove oversize.
- Intermediate Clutch:
  - a. Constant bleed orifice in center support missing.
  - b. Rear accumulator piston oil ring damaged or missing.
  - c. 1-2 accumulator valve stuck in control valve assembly.
  - d. Intermediate clutch piston seals damaged or missing.
  - e. Center support bolt loose.
  - f. Low line pressure (see LOW LINE PRESSURE above).
  - g. Intermediate clutch cup plug in case missing.
  - h. Transmission case valve body face not flat or porosity between channels.
  - i. Manual valve bent and center land not ground properly.
- Direct Clutch:



- a. Restricted orifice in vacuum line to modulator (poor vacuum response).
  - b. Check ball in clutch piston damaged, stuck or missing.
  - c. Defective modulator bellows.
  - d. Center support bolt loose (bolt may be tight in support but not holding support tight to the case).
  - e. Center support oil rings or grooves damaged or missing.
  - f. Clutch piston cracked, seals damaged or missing.
  - g. Front and rear servo pistons and/or seals damaged.
  - h. 3-2 valve, 3-2 valve spring or 3-2 spacer pin installed in wrong location in 3-2 valve train bore.
  - i. Manual valve bent and center land not ground properly.
  - j. Transmission case valve body not flat or porosity between channels.
  - k. Intermediate roller clutch installed backwards.
- In addition, burned clutch plates can be caused by incorrect usage of clutch plates. Also, anti-freeze in transmission fluid can cause severe damaged, such as large pieces of clutch plate material peeling off.

classiccarylbrary.com



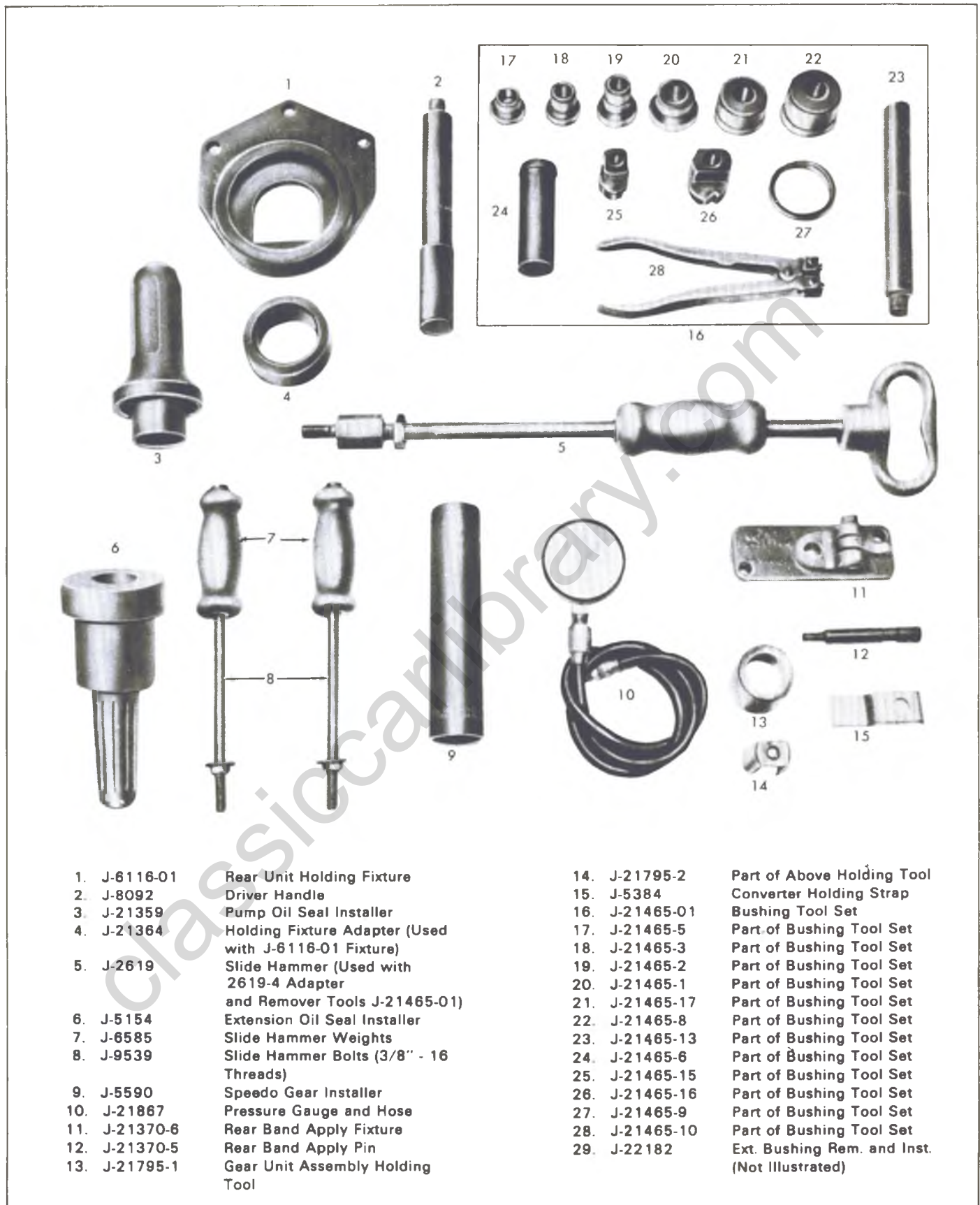

- |               |  |                |   |
|---------------|--|----------------|---|
| 1. J-6116-01  | Rear Unit Holding Fixture  | 14. J-21795-2  | Part of Above Holding Tool                    |
| 2. J-8092     | Driver Handle  | 15. J-5384     | Converter Holding Strap                       |
| 3. J-21359    | Pump Oil Seal Installer  | 16. J-21465-01 | Bushing Tool Set                              |
| 4. J-21364    | Holding Fixture Adapter (Used with J-6116-01 Fixture)                | 17. J-21465-5  | Part of Bushing Tool Set                      |
| 5. J-2619     | Slide Hammer (Used with 2619-4 Adapter and Remover Tools J-21465-01) | 18. J-21465-3  | Part of Bushing Tool Set                      |
| 6. J-5154     | Extension Oil Seal Installer   | 19. J-21465-2  | Part of Bushing Tool Set                      |
| 7. J-6585     | Slide Hammer Weights   | 20. J-21465-1  | Part of Bushing Tool Set                      |
| 8. J-9539     | Slide Hammer Bolts (3/8" - 16 Threads)                               | 21. J-21465-17 | Part of Bushing Tool Set                      |
| 9. J-5590     | Speedo Gear Installer  | 22. J-21465-8  | Part of Bushing Tool Set                      |
| 10. J-21867   | Pressure Gauge and Hose  | 23. J-21465-13 | Part of Bushing Tool Set                      |
| 11. J-21370-6 | Rear Band Apply Fixture  | 24. J-21465-6  | Part of Bushing Tool Set                      |
| 12. J-21370-5 | Rear Band Apply Pin  | 25. J-21465-15 | Part of Bushing Tool Set                      |
| 13. J-21795-1 | Gear Unit Assembly Holding Tool                                      | 26. J-21465-16 | Part of Bushing Tool Set                      |
|               |  | 27. J-21465-9  | Part of Bushing Tool Set                      |
|               |  | 28. J-21465-10 | Part of Bushing Tool Set                      |
|               |  | 29. J-22182    | Ext. Bushing Rem. and Inst. (Not Illustrated) |

Fig. 2ST—Turbo Hydra-Matic 400/475 Special Tools

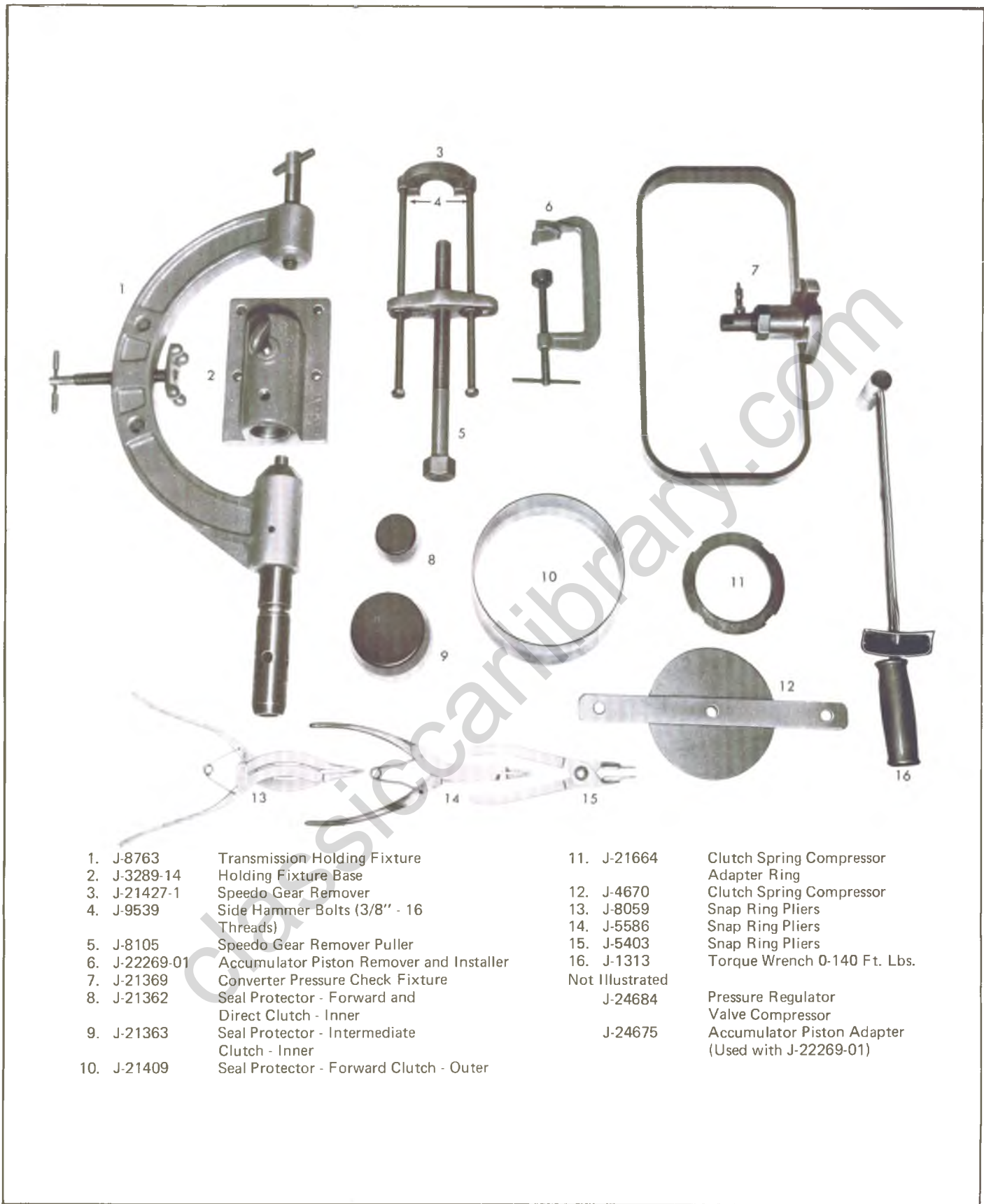

- |               |  |                 |   |
|---------------|--|-----------------|---|
| 1. J-8763     | Transmission Holding Fixture                       | 11. J-21664     | Clutch Spring Compressor Adapter Ring             |
| 2. J-3289-14  | Holding Fixture Base                               | 12. J-4670      | Clutch Spring Compressor                          |
| 3. J-21427-1  | Speedo Gear Remover                                | 13. J-8059      | Snap Ring Pliers                                  |
| 4. J-9539     | Side Hammer Bolts (3/8" - 16 Threads)              | 14. J-5586      | Snap Ring Pliers                                  |
| 5. J-8105     | Speedo Gear Remover Puller                         | 15. J-5403      | Snap Ring Pliers                                  |
| 6. J-22269-01 | Accumulator Piston Remover and Installer           | 16. J-1313      | Torque Wrench 0-140 Ft. Lbs.                      |
| 7. J-21369    | Converter Pressure Check Fixture                   | Not Illustrated |   |
| 8. J-21362    | Seal Protector - Forward and Direct Clutch - Inner | J-24684         | Pressure Regulator Valve Compressor               |
| 9. J-21363    | Seal Protector - Intermediate Clutch - Inner       | J-24675         | Accumulator Piston Adapter (Used with J-22269-01) |
| 10. J-21409   | Seal Protector - Forward Clutch - Outer            |                 |   |

Fig. 3ST—Turbo Hydra-Matic 400/475 Special Tools

## SECTION 8

# FUEL TANKS AND EXHAUST

Also refer to the Emission Control Systems Booklet and Maintenance Schedule Folder for maintenance and warranty information.

### CONTENTS OF THIS SECTION

Description.....	8-1	Diagnosis (Exhaust and ECS System).....	8-13
Service Operations (Incl. Maintenance Items) .....	8-2	Special Tools .....	8-14

### DESCRIPTION

All cab model trucks have fuel tanks relocated and mounted outside of the cab, outboard of the right frame rail. The tank is constructed of two steel sections, seam welded, together. Because of the outside location of the base and optional auxiliary tank, a plastic shield is released for all series and models for 1974. The shield is fitted into seam welded flange to the tank and is bolted to the bracket mounting which is attached to the frame, protecting the full frontal area of the tank. Also a steel "bathtub type" skid plate, is bolted to frame and fuel tank bracket.

On 3/4 and 1 ton forward control models and cowl models, the tank is mounted on the outside of the right frame side rail. A strong mounting of two metal straps anchor these tanks to mounting brackets which are bolted to the frame side member.

On 1/2 and 3/4 ton conventional and 4-wheel drive models, Suburban and Utility, and 1/2 ton forward control models the tank is located to the rear of the axle and between the side rails and envelopes the forward edge of the spare tire. These tanks are supported by two steel straps which are held at either end by a hook into the side rail. Metal to metal contact between tank and brackets or straps is prevented by the use of anti-squeak material.

Upper and lower filler necks vary as to size, length and shape, depending on model requirements. These necks are treated so that rust will not form and get into the fuel system. Lower filler necks are first bolted or riveted (except on P10, CK1-200 (06-14 Models) or on RPO N20, P32 (50 gallon tanks) to the tank, except on cab models, and then sweat soldered in place to eliminate any possibility of leakage at this point.

The fuel pickup pipe is built integrally with the tank gauge unit, located at the top of the tank. A large area,

fine-membrane material is located on the bottom of the fuel pickup pipe. This material is designed to prevent the entrance of dirt or water into the fuel system, and operates with a self-cleaning action.

Frame mounted tanks consist of an upper and lower half, each with a wide flange except for the new motor home 50 gallon tank which is a "wrap" type construction with bulkhead ends seam welded to tank walls.

The two tank sections are seam welded at the flange around the entire tank to assure leakproof construction. Exceptional stiffness is secured by the combination of the welded flanges and depressed ribs in both upper and lower tank sections.

### EVAPORATION CONTROL SYSTEM (ECS)

The Evaporation Control System (ECS) is standard equipment under federal regulations for all truck series rated under 6,000 pounds maximum obtainable GVW and all people carrying vehicles. Important changes have been made to improve performance and increase reliability. The most noteworthy being in the area of fuel fill. Past versions used partial inner tanks as fuel fill limiter devices. Current designs use filler necks extended further into the fuel tank and a revised fill vent tube.

### TANK FILLER NECK GAS CAP—10 SERIES AND TRUCKS CLASSED AS PEOPLE CARRIERS

The truck fuel tank filler cap has a pressure-vacuum safety relief valve.

NOTE: The gas cap requires replacement, only a cap identified on the inside of the cap with "pressure-vacuum" should be used. Failure to use the correct cap can result in a serious malfunction of the system.

## SERVICE OPERATIONS

(INCLUDING MAINTENANCE ITEMS)

### INDEX

Fuel Tanks and Attachments.....	8-2	Exhaust Systems .....	8-11
Fuel Lines.....	8-9	Special Tools .....	8-14
Evaporation Control System (ECS).....	8-9		

## FUEL TANKS AND ATTACHMENTS

**FUEL CAP, FUEL LINES AND FUEL TANK**—The fuel tank, cap and lines should be inspected for road damage which could cause leakage. Inspect fuel cap for correct sealing ability and indications of physical damage. Replace any damaged or malfunctioning parts.

### INDEX

Component Part Replacement.....	8-2	Metering Units (Gauge Sending Unit) .....	8-3
Draining Fuel Tank.....	8-2	Cleaning Fuel Systems .....	8-5
Fuel Tanks.....	8-3		

## COMPONENT PART REPLACEMENT

(REFER TO ILLUSTRATIONS)

### DRAINING FUEL TANK

If the fuel tank does not incorporate a drain plug, it will be necessary to siphon fuel from the tank when draining is needed. The following procedure is recommended.

1. Obtain approximately 10 feet of 3/8" I.D. hose and cut a flap-type slit 18" from one end. Make this cut in the direction of the shorter end of hose (See Figure 1).
2. Insert a small pipe nipple (slightly larger O.D. than the hose I.D.) into the opposite end of hose.
3. Insert the nipple end of siphon hose into the fuel tank filler neck with the natural curl of the hose pointed down. Insert until the hose is heard to strike the bottom of the tank.
4. With the opposite end of the hose in a suitable container, insert an air hose in the downward direction in the flap-type slit and trigger the flow of fuel.

**CAUTION:** Before draining be sure that the fuel tank gauge unit wire or battery negative cable is disconnected.

Always drain gasoline from complete fuel system including carburetor, fuel pump, all fuel lines and fuel tank if the vehicle is to be stored for any appreciable length of time.

This precaution will prevent accumulation of gum formation and resultant poor engine performance.

### GAUGE UNIT OR STRAINER Replacement

The following procedure is intended as a general guide

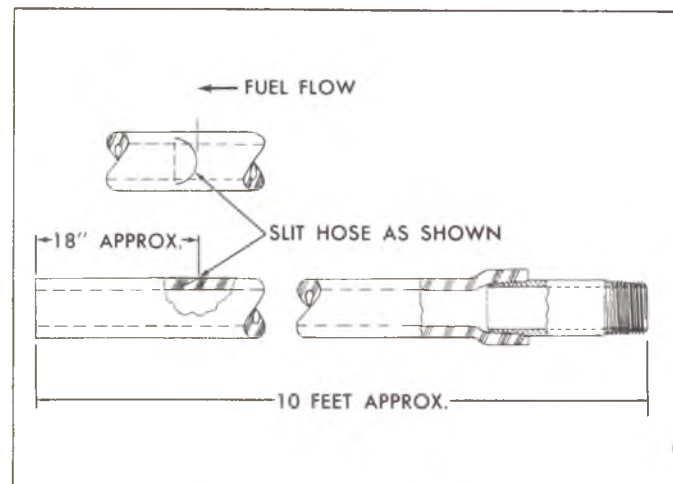

Fig. 1-Siphon Construction

only and will vary according to truck series and model.

1. Drain tank as previously outlined to a level below gauge unit mounting location or if unit is inaccessible remove fuel tank.
2. Disconnect fuel feed line and wiring from gauge unit.
3. Unlock gauge cam ring using Tool J-24187 and remove gauge unit from tank.

NOTE: On some chassis mounted tanks, remove gauge attaching screws and then disengage unit from tank.

4. Replace or clean strainer with compressed air as required.
5. Install gauge unit using reverse of removal procedure.

### GAS CAP IDENTIFICATION

The easiest way to identify the correct filler neck gas cap for trucks with the Evaporation Control System (ECS), is to check for the words "pressure-vacuum" on the inside of the cap. Also check for proper gas cap fit.

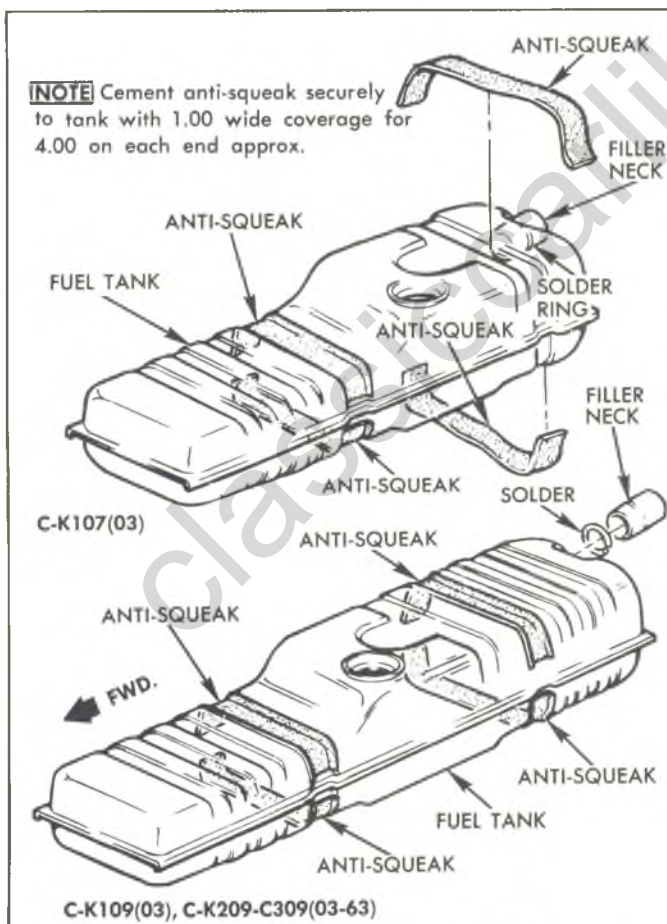

Fig. 2—Fuel Tank - Cab and Crewman Models

If gas cap replacement is required, always check vehicle identification and order by part number.

### FUEL TANKS - REMOVE AND INSTALL

**WARNING:** Before attempting fuel tank removal, always; remove battery negative cable from battery, place "NO SMOKING" signs and a CO2 fire extinguisher near work area, wear safety glasses, and siphon or pump fuel from tank into an explosive proof container.

NOTE: The optional auxiliary fuel tank is located outboard of the left frame rail in the same manner as the base tank in 1973. It is connected to the frame rail as illustrated.

### OUTSIDE FRAME RAIL FUEL TANKS- CAB AND CREWMAN MODELS (FIG. 2)

#### Removal and Installation

1. Drain tank as previously outlined. Also see Warning above.
2. Disconnect fuel lines, meter wire and ground lead.
3. Remove strap supports (lines, vent) and clips.
4. Loosen clamps from filler neck and vent line.
5. Remove strap bolts and lockwashers from tank front and rear locations on inside frame rail.
6. Remove tank from frame simultaneously disengaging filler neck hose from filler neck.
7. Remove meter assembly from fuel tank using Tool J-24187.
8. To install, reverse removal procedure.

### FUEL TANK (FIG. 3) - VAN

#### Removal and Installation

1. Drain tank.
2. Raise vehicle on hoist.
3. Unclamp filler neck and vent tube hose.
4. Unclamp gauge unit hose at frame end.
5. Support tank and remove support strap(s).
6. Lower tank until gauge unit wiring can be removed.
7. Remove fuel tank.
8. Install in the reverse order.
9. Lower vehicle and remove from hoist.

### 1/2 AND 3/4 TON CHASSIS CENTER AND AUXILIARY MOUNTED TANKS

#### Removal and Installation

1. Drain tank.

## 8-4 FUEL TANKS AND EXHAUST

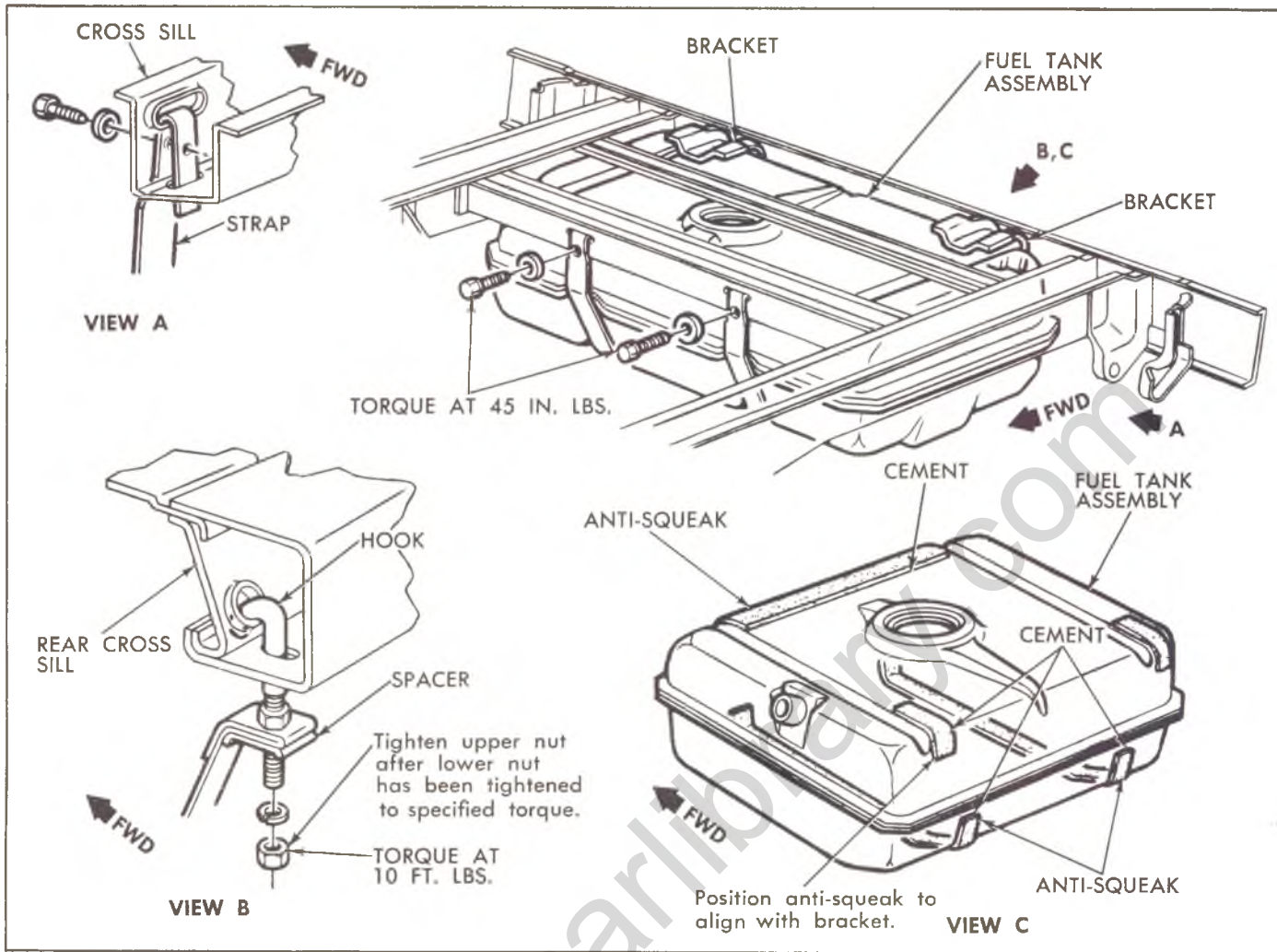

Fig. 3—Fuel Tank - Van Models

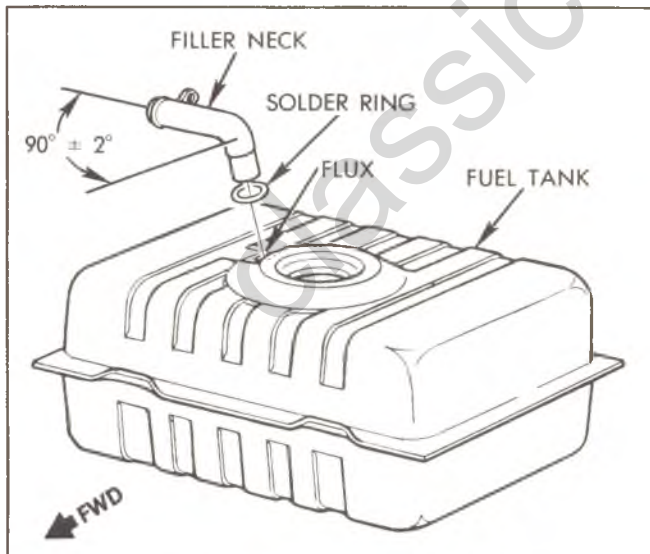

Fig. 4—Fuel Tank - C-K 10-20 (06-14)

2. Raise vehicle on hoist.
3. Unclamp upper filler neck and vent tube hose.
4. Unclamp gauge unit hoses at frame end.
5. Support tank and remove support strap(s).
6. Lower tank until gauge unit wiring can be removed.
7. Remove fuel tank.
8. Install in the reverse order, being sure that the anti-squeak material is replaced.
9. Lower vehicle and remove from hoist.

### P MODELS AND 1 TON CHASSIS (FRAME) MOUNTED TANKS

#### Removal and Installation

1. Drain tank.
2. Remove filler neck.
3. Disconnect gauge unit fuel line and wiring. Ignition switch must be in OFF position.
4. Remove bolts attaching tank supports to frame.



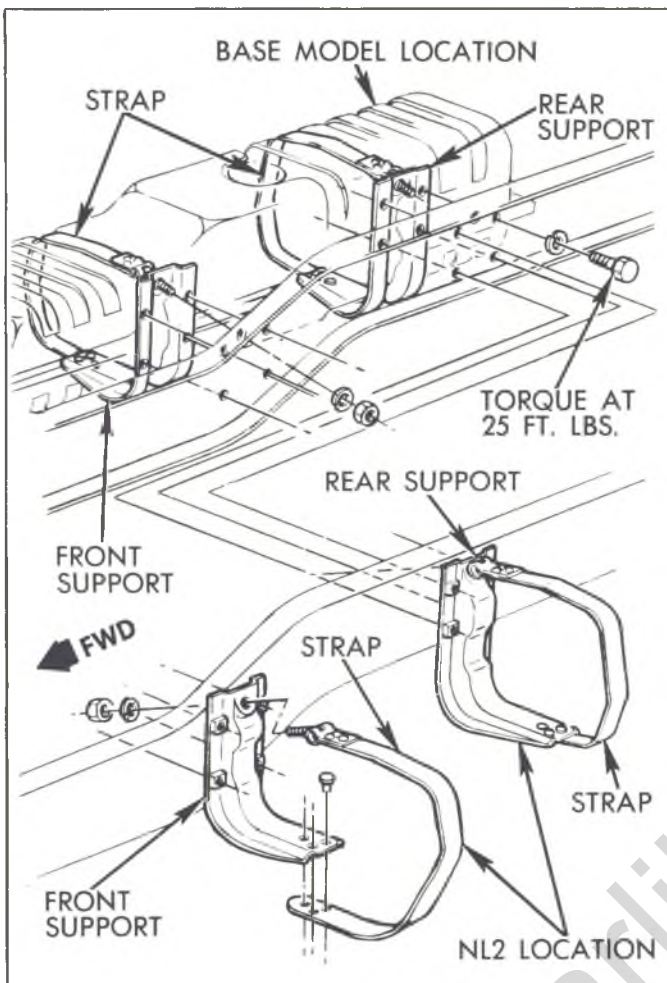

Fig. 5—Fuel Tank Mounting - Cab and Crewman Models

5. Remove tank complete with mounting brackets and support straps.
6. Remove tank from brackets and support straps, if necessary.
7. To install, reverse the removal procedures. Replace all anti-squeak material.

### CLEANING FUEL SYSTEMS

If trouble is due to contaminated fuel or foreign material that has been put into the tank, it can usually be cleaned. If tank is rusted internally, it should be replaced.

1. Disconnect battery and ignition coil primary wire (+ wire on ignition coil).
2. Drain fuel tank. (See DRAINING FUEL TANK.)
3. Remove fuel tank. (See FUEL TANKS - REMOVE AND INSTALL.)
4. Remove fuel inlet filter at carburetor and inspect for contamination. If filter is plugged, replace. (Leave fuel line disconnected.)
5. Locate tank away from heat, flame or other source of ignition. Remove fuel gauge tank unit and

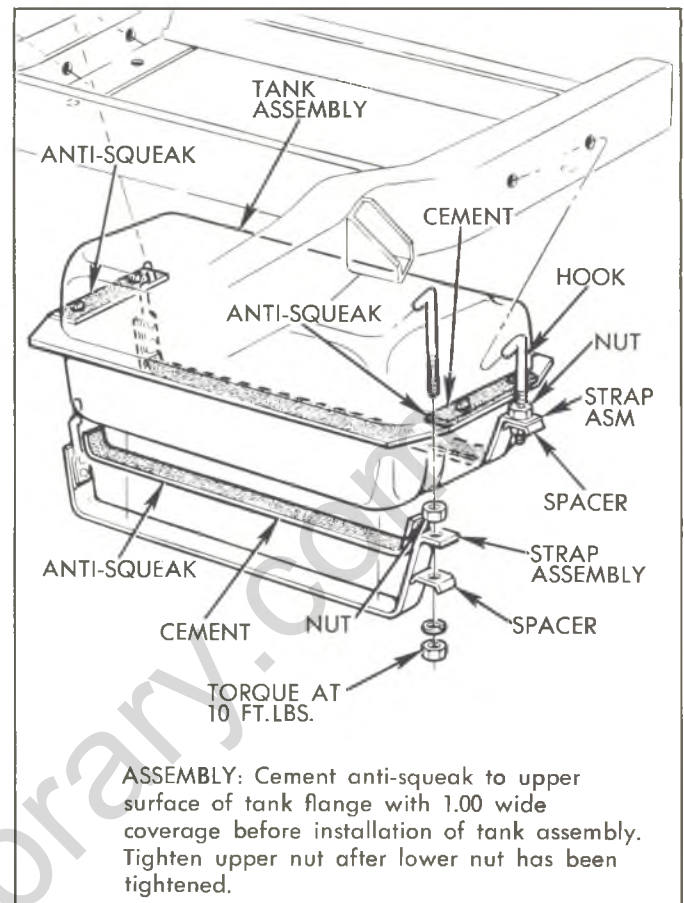

Fig. 6—Fuel Tank and Mounting - P-10 Models

inspect condition of filter. If filter is contaminated, a new filter should be installed upon reassembly.

6. Complete draining of tank by rocking it and allowing fuel to run out of tank unit hole.
  7. Purge fuel tank with steam or running hot water for at least five minutes. Pour water out of tank unit hole. (Rock tank to assure complete removal of water.)
- IMPORTANT:** This procedure will not remove fuel vapor. Do not attempt any repair on tank or filler neck where heat or flame is required.
8. Disconnect inlet fuel line at pump and use air pressure to clean fuel line and fuel return line (if equipped). Apply air pressure in the direction fuel normally flows through line.
  9. Use low air pressure to clean pipes on tank unit.
  10. Install new filter on fuel tank unit if required. Install fuel tank unit with new gasket into tank and install tank. Connect tank unit wires and all fuel lines except pump to carburetor line. (See REMOVAL OF TANK for proper procedure).
  11. Connect a hose to fuel line at carburetor; insert other end of hose into a one gallon fuel can.

## 8-6 FUEL TANKS AND EXHAUST

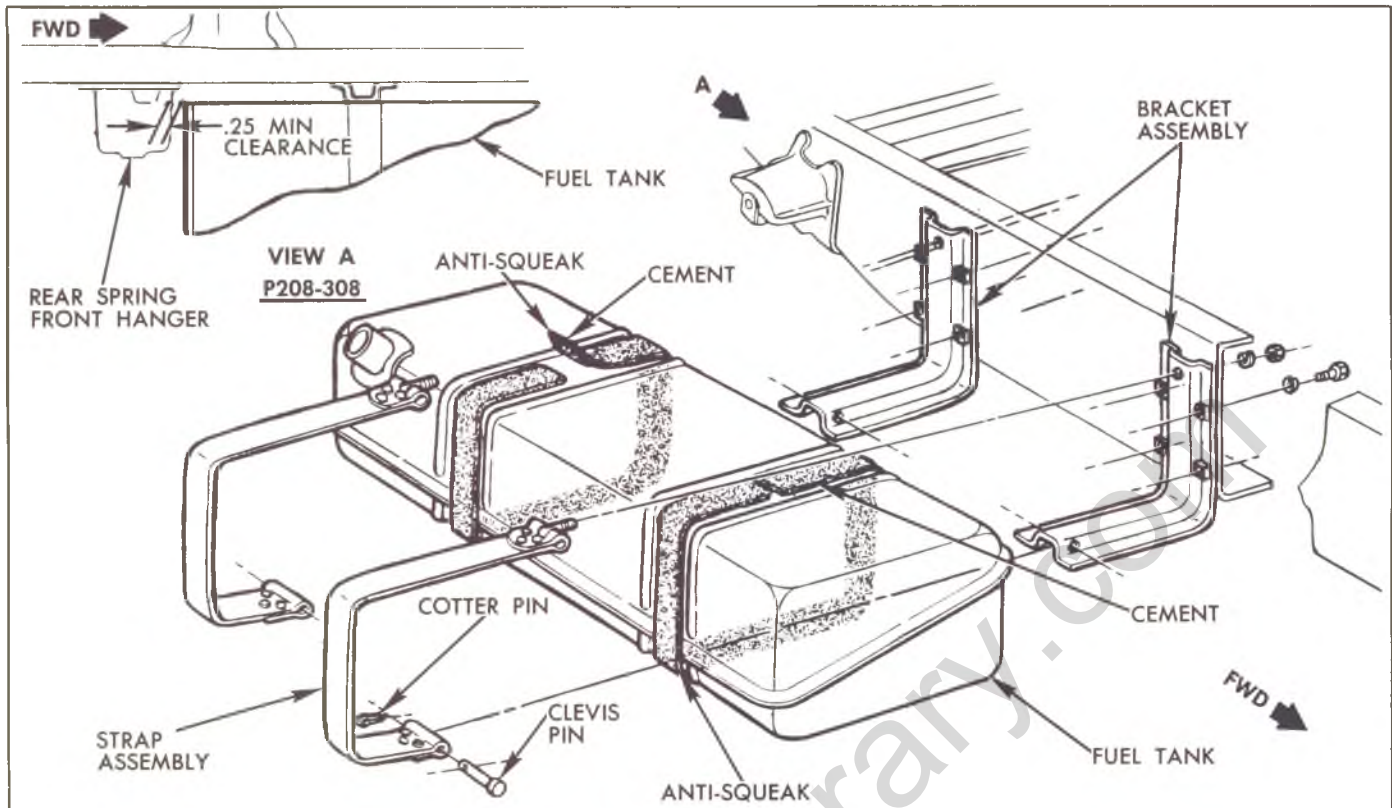

Fig. 7--Fuel Tank and Mounting - P20-30 Models

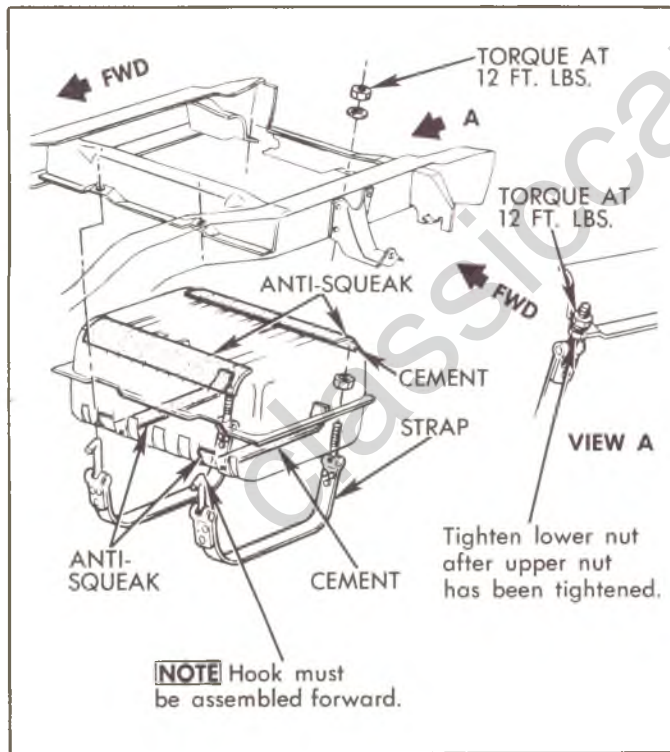

Fig. 8--Fuel Tank Mounting, C-K 10-20 (06-14) Series

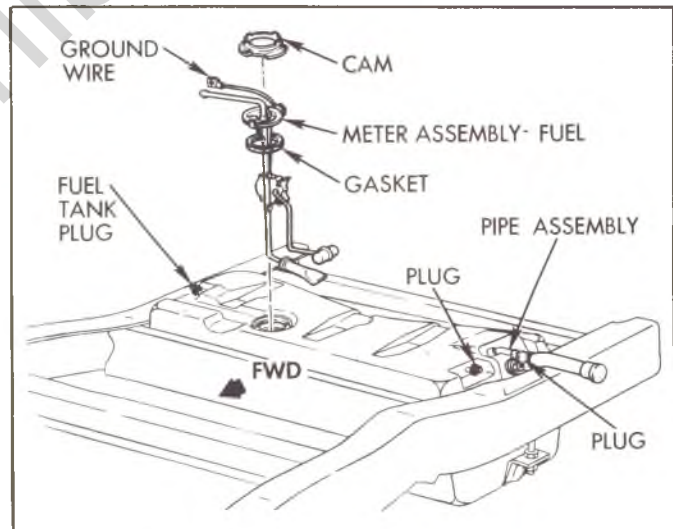

Fig. 9--Fuel Tank Lower Neck and Meter, P 10 Series

COIL PRIMARY WIRE (+ TERMINAL) IS DISCONNECTED.

12. Connect battery cable. **MAKE SURE IGNITION**

13. Put six gallons of clean fuel in tank and operate starter to pump two quarts of fuel into fuel can. This will purge fuel pump.
14. Remove hose and connect fuel line to carburetor.
15. Connect coil primary wire.

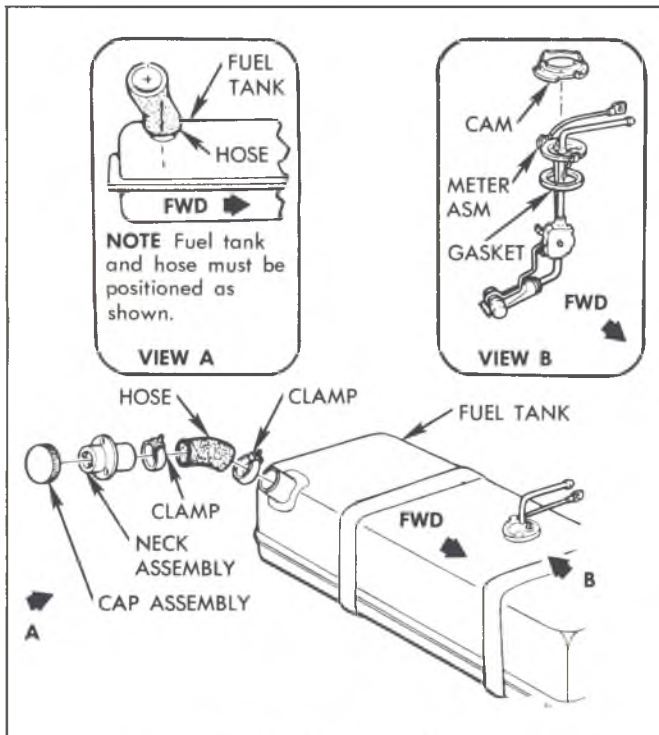

Fig. 10--Fuel Tank Neck and Meter (P20-30)

### FUEL TANK PURGING PROCEDURE

1. Remove fuel gauge unit and drain all remaining fuel from tank.
2. Visually inspect interior cavity of tank; if any fuel is evident, drain again.
3. Move tank to flushing area (wash rack).
4. Pour gasoline emulsifying agent and water solution into the tank and agitate mixture for 2 to 3 minutes, wetting all interior surfaces.

NOTE: For correct gasoline emulsifying agent - water mixture, refer to the emulsifying agent manufacturer's specifications. Use an available emulsifying agent such as "Product-Sol No. 913" or equivalent.

5. Fill tank (with water) to capacity and agitate again.
6. Empty contents into floor drain.
7. When empty, refill to overflowing with water to completely flush out remaining mixture and then empty tank.
8. If any vapor is present, repeat Steps 4 thru 8. Repeat as necessary until there is no evidence of fuel vapor.
9. Dry tank with compressed air and perform required service work.

### FUEL TANK LEAK TEST PROCEDURE

1. Plug all outlets as follows:
  - a. Use a known good pressure-vacuum filler cap for filler neck.
  - b. Install tank unit and plug fuel line.
  - c. Plug all except one of the vent tubes using a single short piece of fuel line hose.
  - d. Install another short piece of fuel line hose on the remaining open vent tube.
2. Apply air pressure to tank through open vent tube. Use extreme caution to prevent rupturing the tank. When air can be heard escaping from the filler neck cap (approximately 1 to 1 1/2 lbs. of pressure) pinch the fuel line hose to retain pressure.
3. Test repaired area for leaks with soap solution or by submersion. If leak is noted, make repair and retest.

## 8-8 FUEL TANKS AND EXHAUST

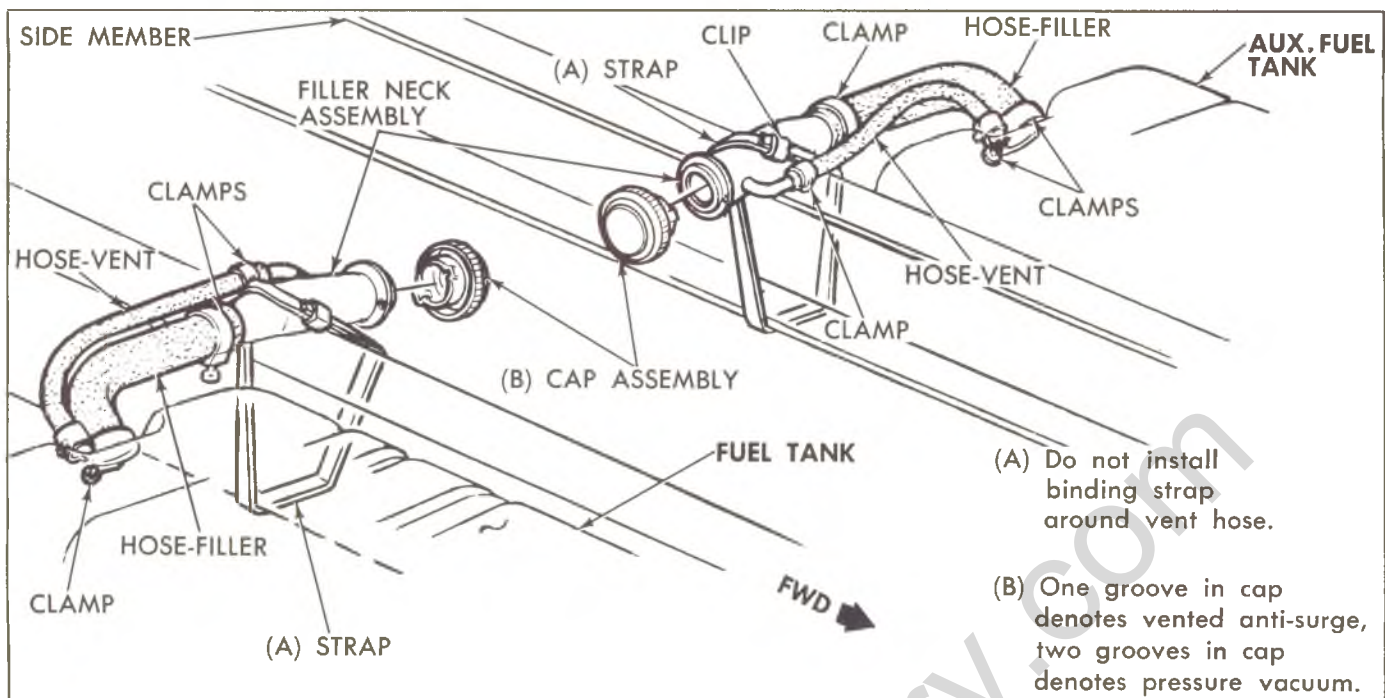

Fig. 11—Filler Neck - C-K (03-63)

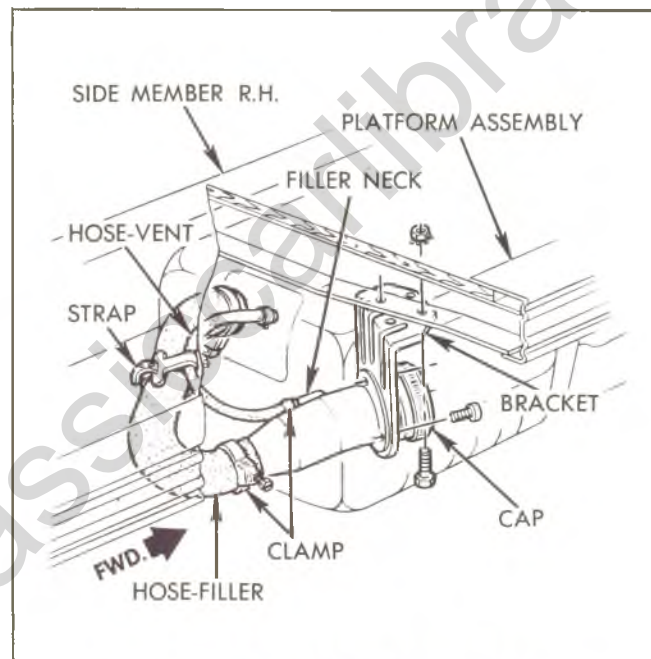

Fig. 12—Filler Neck C-K C-20-30 (03) and E56

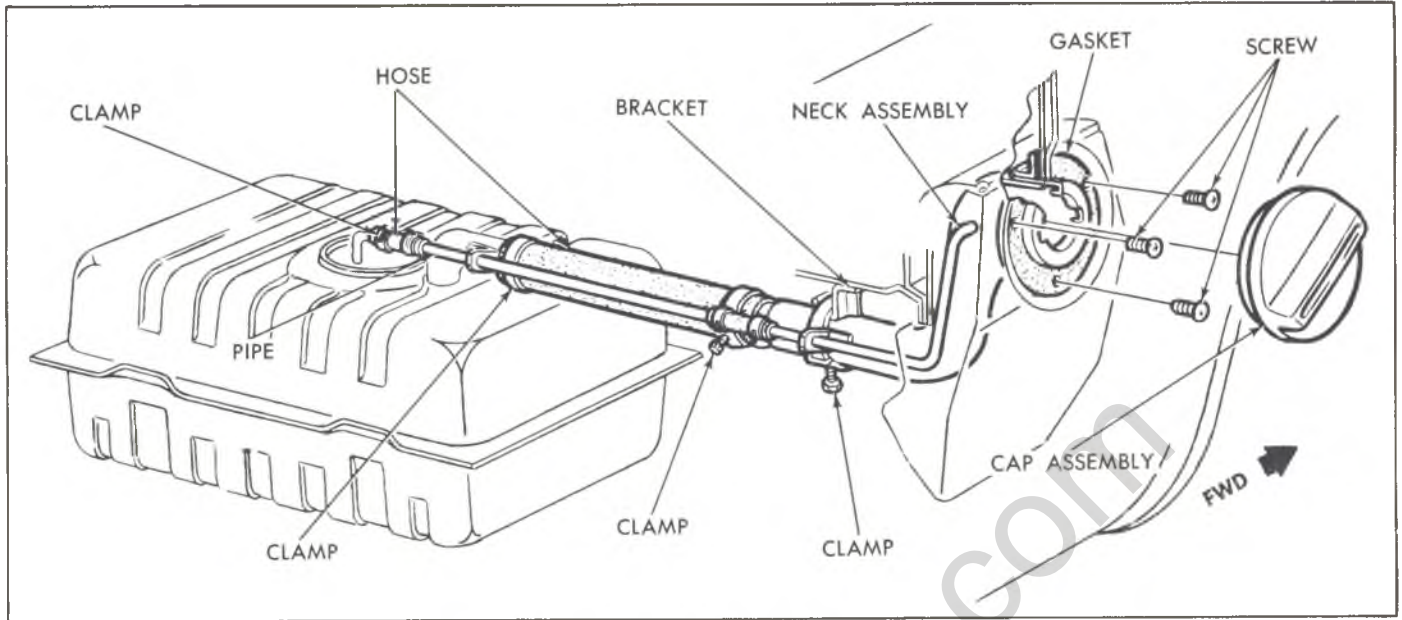

Fig. 13—Filler Neck C-K 10-20 (06-14)

## FUEL LINES

**NOTE:** When steel tubing replacement is required on any vehicle, only released steel tubing or its equivalent should be used for applicable replacement. Under no conditions should copper or aluminum tubing be used to replace steel tubing. All steel tubing should be flared using the upset (double lap) flare method which is detailed in Section 5 of the Service Section in applicable shop manuals.

The fuel lines should be inspected occasionally for leaks, kinks or dents. If evidence of dirt is found in the carburetor, fuel pump or on a disassembly, the lines should be disconnected and blown out. Check the fuel strainer in the tank for damage or omission.

When replacing a fuel line, only seamless steel tubing is to be used. Also, the ends of the tubing must be double-flared using commercially available double flaring tools. All fuel lines must be properly routed and retained.

### FRAME MOUNTED FUEL FILTER

Frame mounted fuel filters are standard equipment on some vehicles. The fuel filter element should be replaced at the recommended mileage intervals outlined in Section 0, this manual.

### FUEL LINE SERVICE

The fuel lines should be inspected occasionally for leaks, kinks or dents. If evidence of dirt is found in the carburetor, fuel pump or on a disassembly, the lines should be disconnected and blown out. Check the fuel strainer in the tank for damage.

When replacing a metal fuel line, only seamless steel tubing is to be used. Also, the ends of the tubing which join at a connector, must be double-flared using commercially available double flaring tools. All fuel lines must be properly routed and retained.

## EVAPORATION CONTROL SYSTEM

Also refer to the Emission Control Systems Booklet and Maintenance Schedule Folder for maintenance and warranty information.

### INDEX

Service Information.....	8-10	Canister Purge Valve .....	8-11
Component Part Replacement.....	8-10	Separator .....	8-11
Canister and/or Canister Filter.....	8-10	Fuel Tank .....	8-11

## 8-10 FUEL TANKS AND EXHAUST

**EVAPORATION CONTROL SYSTEM FUEL & VAPOR LINES**-ALL fuel and vapor lines and hoses must be in good condition with no signs of leakage. Any damaged or deteriorated lines or hoses must be replaced. All lines should be inspected for proper connections and correct routing.

Before making part replacement, refer to "hoses" under Service Information and also "Caution" below covering steel tubing part replacement.

**CAUTION:** *When steel tubing replacement is required on any vehicle, only released steel tubing or its equivalent should be used for applicable replacement. Under no conditions*

*should copper or aluminum tubing be used to replace steel tubing. All steel tubing should be flared using the upset (double lap) flare method which is detailed in Section 5 of the Service Section in applicable shop manuals.*

**EVAPORATION CONTROL SYSTEM CANISTER** - Check canister for cracks or damage when replacing the canister filter. Replace parts as necessary.

**FILTER-ECS-CANISTER**-Remove canister and replace filter every 24,000 miles in lower section of canister.

## SERVICE INFORMATION

The Components of this system are:

Correct replacement caps may be obtained from your dealer.

### FUEL TANK FILLER NECK GAS CAP

The fuel tank filler cap has a new two-step removal and installation procedure plus a pressure-vacuum relief valve.

It is equipped with a double set of locking tangs. To remove:

- Rotate cap one-half turn counterclockwise to clear the first set of tangs from the slots inside the filler neck.
- This will allow any residual pressure to escape.
- Pull the cap outward and rotate one quarter turn counterclockwise to clear second set of tangs. Then remove the cap.
- To install, reverse this procedure.

**NOTE:** If this cap requires a replacement, only a cap with these same features should be used. Failure to use the correct cap can result in a serious malfunction of the system.

### GASOLINE TANK

The gasoline tanks incorporate special extended filler necks and vents and also external hose connections.

### LIQUID VAPOR SEPARATOR

The separator mounts to the right or left hand side of the gasoline tank. If service is necessary, the entire assembly must be replaced.

### CANISTER FILTER

The canister is mounted on the side of the engine compartment. A filter is mounted in the bottom of the canister. It is to be replaced according to the recommended maintenance schedule.

### HOSES

When replacing any evaporative emission hose, use only replacement hose marked "EVAP". No other type of hose is to be used.

## COMPONENT PART REPLACEMENT

### CANISTER WITH CANISTER FILTER

#### Removal

1. Raise vehicle on hoist.
2. Note installed position of hoses on canister.

3. Disconnect hoses from top of canister.
4. Loosen clamps and remove canister.

If replacing filter, pull out filter from bottom of canister.

**Inspection**

1. Check hose connection openings. Assure that they are open.
2. Check operation of purge valve by applying vacuum to the valve. A good valve will hold vacuum.

**Installation**

1. Install new filter.
2. Assemble bottom of canister to canister body.
3. Install canister and tighten clamp bolts.
4. Connect hoses to top of canister in same position as in Step 3 above.

**CANISTER PURGE VALVE (Fig. 14)****Disassembly**

1. Disconnect lines at valve.
2. Snap off valve cap (slowly remove cap as diaphragm is under spring tension). Remove diaphragm, spring retainer and spring.
3. Replace parts as necessary. Check orifice openings.

**Assembly**

1. Install spring, spring retainer, diaphragm and cap.
2. Reinstall canister as previously outlined, connect lines to valve.

**SEPARATOR****Removal**

1. Raise vehicle on hoist.
2. Disconnect lines from separator.

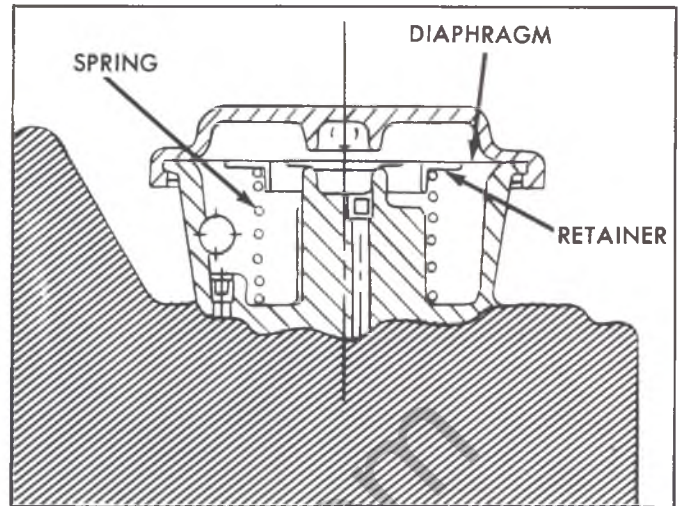

Fig. 14—Purge Valve

3. Remove retaining screw and remove separator.

**Installation**

1. Install separator and its retaining screw.
2. Connect lines to separator.

NOTE: If replacing hose, use only replacement hose marked EVAP.

3. Lower vehicle and remove from hoist.

**FUEL TANK**

Removal and installation procedures are the same as outlined for other models with exception of disconnecting and connecting fuel tank-to-separator vent lines. Refer to Fuel Tank Section.

**EXHAUST SYSTEM**

**IMPORTANT:** Make sure that exhaust system components have at least 3/4 inch clearance from the floor pan to avoid possible overheating of the floor pan and possible damage to the passenger compartment carpets.

**SERVICE INFORMATION**

When installing a new exhaust pipe, muffler or tailpipe, on any model, care should be taken to have the correct alignment and relationship of the components to each other. Particular care should be given to the installation of the exhaust pipe and crossover pipe assembly on V-8 engine single exhaust systems. Incorrectly assembled parts of the exhaust system are frequently the cause of annoying noises and rattles due to improper clearances

or obstructions to the normal flow of gases. Leave all clamp bolts and muffler strap bolts loose until all parts are properly aligned and then tighten, working from front to rear.

NOTE: When reinstalling exhaust pipe to manifold, always use new packings and nuts. Be sure to clean manifold stud threads with a wire brush before installing the new nuts.

## COMPONENT PART REPLACEMENT

EXHAUST SYSTEM PIPES AND RESONATORS REARWARD OF THE MUFFLERS MUST BE REPLACED WHENEVER A NEW MUFFLER IS INSTALLED.

Truck exhaust systems vary according to series and model designation. Series 10-30 trucks use a split-joint design system in which the exhaust pipe-to-muffler are clamped together and muffler-to-tailpipe connections are welded together. All mufflers and tailpipes are welded assemblies (no clamps) in 1974.

NOTE: All 10-20-30 Series exhaust have been aluminized. Always use the correct replacement parts when servicing these systems.

When installing a new exhaust pipe or muffler and

tailpipe, on any model, care should be taken to have the correct alignment and relationship of the components to each other. Particular care should be given to the installation of the exhaust pipe and crossover pipe assembly on V-8 engine single exhaust systems. Incorrectly assembled parts of the exhaust system are frequently the cause of annoying noises and rattles due to improper clearances or obstructions to the normal flow of gases. Leave all clamp bolts and muffler bolts loose until all parts are properly aligned and then tighten, working from front to rear.

NOTE: When reinstalling exhaust pipe to manifold, always use new packings and nuts. Be sure to clean manifold stud threads with a wire brush when installing the new nuts.

Classiccarlibrary.com



## DIAGNOSIS

## EXHAUST SYSTEMS

CONDITION	POSSIBLE CAUSE	CORRECTION
Leaking Exhaust Gases	Leaks at pipe joints.	Tighten U-bolt nuts at leaking joints to 150 inch-pounds.
	Damaged or improperly installed gaskets.	Replace gaskets as necessary.
	Loose heat tube connections.	Replace gaskets as required. Tighten stud nuts or bolts to specifications.
	Burned or rusted out heat tubes.	Replace heat tubes as required.
Exhaust Noises	Leaks at manifold or pipe connections.	Tighten clamps at leaking connections.
	Burned or blown out muffler.	Replace muffler assembly.
	Burned or rusted out exhaust pipe.	Replace exhaust pipe.
	Exhaust pipe leaking at manifold flange.	Tighten attaching bolts nuts to 17 foot-pounds.
	Exhaust manifold cracked or broken.	Replace manifold.
	Leak between manifold and cylinder head.	Tighten manifold to cylinder head stud nuts or bolts to specifications.
Engine Hard to Warm Up Or Will Not Return to Normal Idle	Heat control valve frozen in the open position.	Free up manifold heat control using a suitable manifold heat control solvent.
Manifold Heat Control Valve Noise	Thermostat broken.	Replace thermostat.
	Broken, weak or missing anti-rattle spring.	Replace spring.

## EVAPORATION CONTROL SYSTEM (ECS)

The Evaporation Control System should not require any maintenance other than the charcoal canister filter replacement. See "Emissions Control Section" of this manual. Any loss of fuel or vapor from the fuel filler cap would indicate one or more of the following:

- (1) An unsatisfactory seal between cap and filler neck.
- (2) A malfunction of filler cap release valve. A quick check of the filler fuel cap may be made by placing

against the mouth and blowing into the hole in the release valve housing. An immediate leak with light blowing or lack of release with hard blowing indicates a defective or incorrect unit.

- (3) All vapor lines plugged between fuel tank and vapor separator.
- (4) Plugged vapor lines between the vapor separator and the canister.

## SPECIAL TOOLS

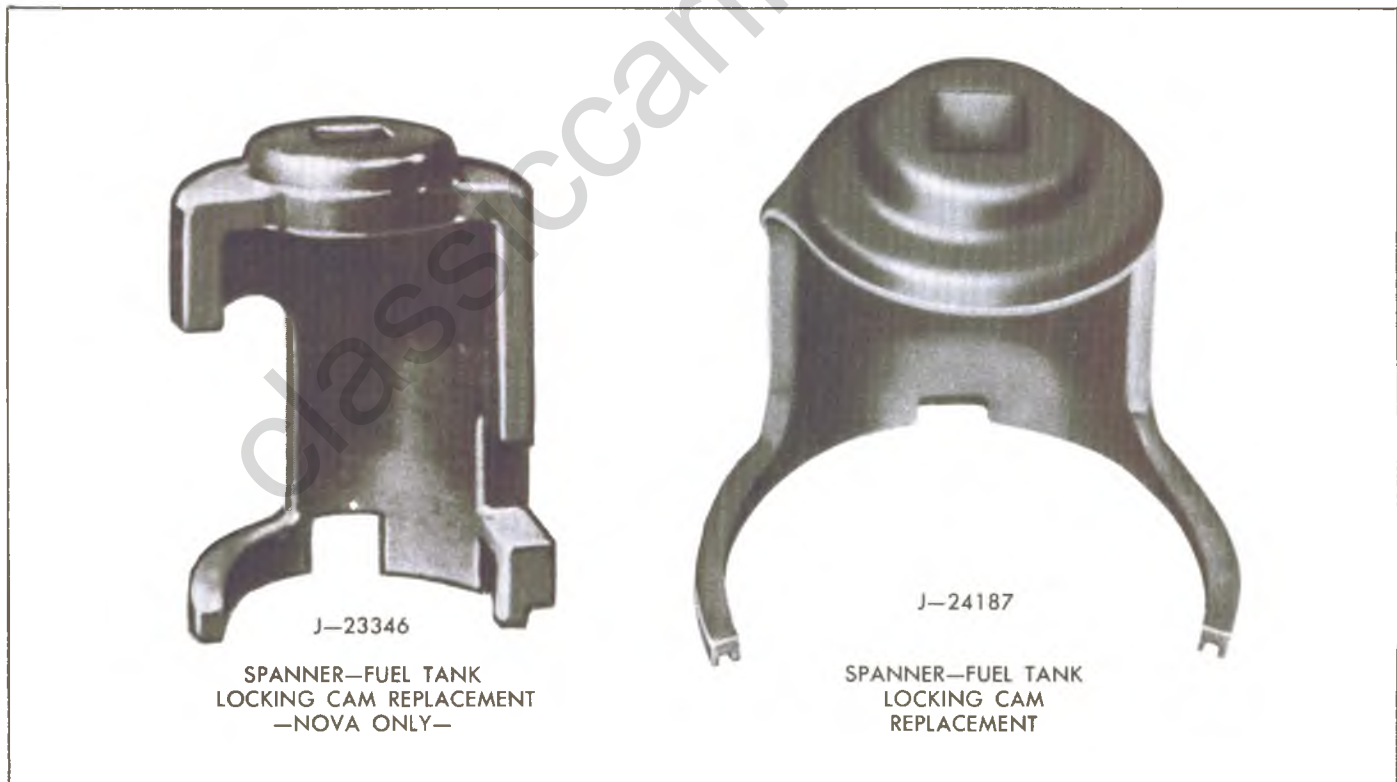

Fig. 15--Special Tool J-24187

## SECTION 9

# STEERING

The following caution applies to one or more steps in the assembly procedure of components in this portion of the manual as indicated at appropriate locations by the terminology "See Caution on page 1 of this Section".

**CAUTION THIS FASTENER IS AN IMPORTANT ATTACHING PART IN THAT IT COULD AFFECT THE PERFORMANCE OF VITAL COMPONENTS AND SYSTEMS, AND/OR COULD RESULT IN MAJOR REPAIR EXPENSE. IT MUST BE REPLACED WITH ONE OF THE SAME PART NUMBER OF WITH AN EQUIVALENT PART IF REPLACEMENT BECOMES NECESSARY. DO NOT USE A REPLACEMENT PART OF LESSER QUALITY OR SUBSTITUTE DESIGN. TORQUE VALUES MUST BE USED AS SPECIFIED DURING REASSEMBLY TO ASSURE PROPER RETENTION OF THIS PART.**

### CONTENTS OF THIS SECTION

General Description.....	9-2
Theory of Operation .....	9-2
Maintenance and Adjustments.....	9-24
Component Replacement and Repairs.....	9-29
Diagnosis.....	9-71
Special Tools.....	9-99

### INDEX

General Description.....	9-2	Intermediate Steering Shafts with Pot Joint	
Theory of Operation .....	9-2	Couplings .....	9-30
Steering Ratio .....	9-2	Intermediate Steering Shaft with Universal	
Manual Steering Gear .....	9-4	Joint Couplings .....	9-31
Steering Columns .....	9-6	Steering Gear.....	9-32
Tilt Columns .....	9-7	Pitman Shaft Oil Seal Replacement .....	9-33
Power Steering System .....	9-10	Directional Signal Switch .....	9-33
Power Steering Gear .....	9-11	Lock Cylinder .....	9-35
Power Steering Pump .....	9-16	Ignition Switch.....	9-37
Steering Linkage.....	9-22	Steering Column.....	9-37
Maintenance and Adjustments.....	9-24	Removal .....	9-39
Lubrication .....	9-24	Column Disassembly (Except Tilt).....	9-39
Adjustments.....	9-24	Column Assembly (Except Tilt).....	9-41
Steering Gear - Manual .....	9-24	Column Disassembly - Tilt.....	9-43
Steering Gear High Point Centering.....	9-25	Column Assembly - Tilt.....	9-45
Steering Wheel Alignment .....	9-25	Column Installation - Mandatory	
Steering Column Lower Bearing Adjustment.....	9-25	Sequence .....	9-47
Shifter Tube Adjustment.....	9-26	Steering Column Service G and P .....	9-48
Power Steering Gear .....	9-26	Upper Bearing G and P .....	9-48
Belt Tension.....	9-27	Lower Bearing G and P.....	9-48
Fluid Level.....	9-27	Directional Switch.....	9-48
Bleeding System.....	9-27	Tilt Column Bearing Housing .....	9-50
System Checks.....	9-28	Column Removal.....	9-51
Component Replacement and Repairs.....	9-29	Disassembly Standard Column .....	9-52
Steering Wheel.....	9-29	Assembly Standard Column .....	9-53
Steering Coupling.....	9-29	Disassembly Tilt Column.....	9-53
Flexible Type .....	9-29	Assembly Tilt Column.....	9-56

## 9-2 STEERING

Column Installation P Series.....	9-58	Diagnosis.....	9-71
Column Installation G Series.....	9-59	Steering Linkage.....	9-71
Steering Linkage.....	9-59	Manual Steering Gear.....	9-73
Tie Rod.....	9-59	Steering Column (C and K).....	9-75
Relay Rod.....	9-62	Collision Diagnosis.....	9-75
Idler Arm.....	9-63	Automatic Column.....	9-76
Pitman Arm.....	9-63	Manual Column.....	9-80
Steering Connecting Rod.....	9-64	Tilt Column.....	9-81
Power Steering System.....	9-64	Electrical Analyzer J-23980.....	9-82
Power Gear.....	9-64	Signal Switch.....	9-84
Pump.....	9-65	Power Steering System.....	9-88
Hoses.....	9-65	External Leakage.....	9-94
		Special Tools.....	9-99

## GENERAL DESCRIPTION

The steering gear is of the recirculating ball type. This gear provides for ease of handling by transmitting forces from the wormshaft to the pitman shaft through the use of ball bearings.

The steering column is connected to the steering gear by a flexible coupling. This coupling incorporates a capturing strap which is designed to prevent column-to-coupling deflection from exceeding the length of the coupling alignment pins.

The steering columns for C and K Series Trucks are

basically the same as passenger vehicle columns. The G and P Series trucks use the same type of columns as in 1972. Optional tilt columns are available for all Series trucks except P.

The trucks incorporate "Forward Steering" whereas the steering linkage is located forward of the front crossmember. Steering effort is transmitted to left and right hand adjustable tie rod through a relay rod. The relay rod is connected to an idler arm on the right and to the pitman arm on the left.

## THEORY OF OPERATION

### STEERING RATIO

The ratio of a steering system is the relationship of steering wheel movement to that of the front wheels - that is, the amount, in degrees, that the steering wheel must be turned to turn the front wheels one degree.

For example, if a truck with power steering has a steering ratio of 17.5:1, and that is a constant ratio gear, it is necessary to turn the steering wheel approximately 17.5 degrees for each degree of turn desired.

Part of the ratio is developed in the linkage, but the greatest part of the overall ratio is developed in the steering gear itself.

Comparatively, vehicles with manual steering utilize steering ratios of 24:1 to help minimize the steering effort.

With variable ratio power steering the steering ratio varies continuously from a moderate 16.0:1 or 15.0:1 for straight-ahead driving to a low 13.1:1 in full turns.

From the straight-ahead position, the steering ratio stays constant for the first 40 degrees of steering wheel movement, then decreases very gradually at first. This provides precise steering control for highway driving with a ratio always higher than 15:1, as passing or even

steering through curves seldom requires more than a quarter turn of the steering wheel.

When cornering, such as at an intersection, the ratio spread will be somewhat broader - anywhere between 16:1 and 14.1:1 -- as the steering necessary generally ranges from a half to a full turn of the steering wheel.

While this provides an excellent average cornering ratio of about 14:1, the most important factor is that the response increases as the need increases.

The low end of the ratio spread is utilized only near the extremes of the steering wheel travel--after approximately one full turn. Since the steering wheel is generally turned to its limit only when parking or backing up, the added maneuverability of these extreme low ratios is purely a bonus, since directional stability is not a factor at low speeds.

The design of the sector and rack are responsible for the steering flexibility.

Notice that the center tooth of the variable ratio sector (C & K) is longer than the teeth on either side, while all teeth of the conventional sector (G & P) are of equal length.

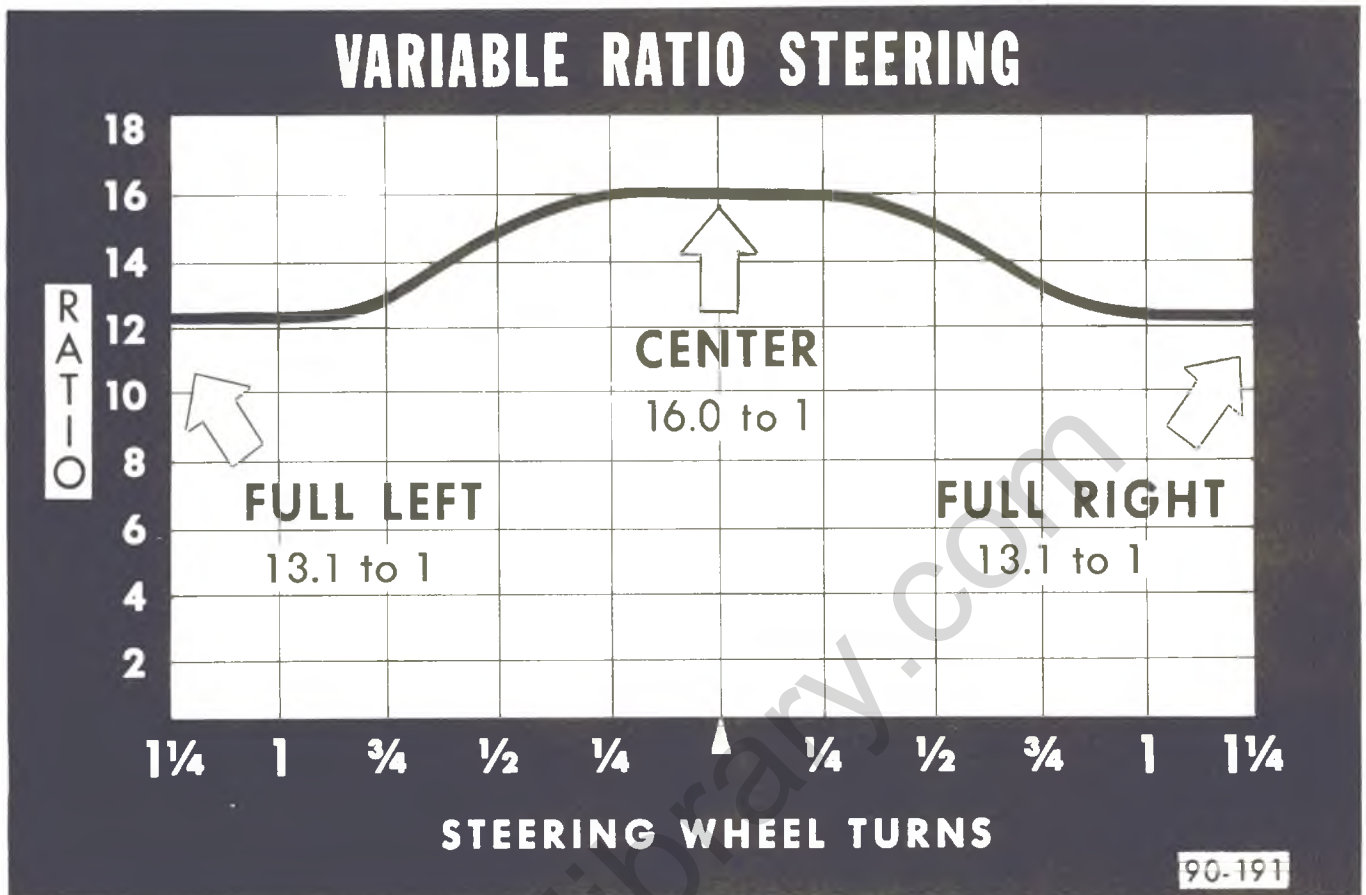

Fig. 1—Steering Ratio

Since the sector, like any gear, is basically a series of levers, it is easily seen that any movement of the rack will always cause the conventional sector to swing the pitman arm in the same ratio—that is, to turn the pitman arm the same number of degrees with each tooth in the sector.

To increase or decrease the ratio, it is only necessary to change the length of the sector teeth, and we see that a low ratio, or smaller radius sector with shorter teeth, produces a greater pitman arm movement than the high ratio sector with its longer teeth and greater leverage.

On this basis, the variable ratio sector is in reality one long high ratio lever at the center flanked by two lower ratio levers for left and right turns.

Since only the tip of the long center tooth is in contact with the rack when the front wheels are straight, initial movement of the rack in either direction causes a relatively small response of the sector and pitman arm because of the high ratio that results from this long lever relationship.

As a result, the steering ratio remains a nearly constant 16.0:1 for the first 40 degrees of steering wheel movement either direction from center.

Turning the steering wheel further, the effective length of the lever is reduced as the point of contact now rolls

down the side of the center tooth, to act as a shorter radius.

As a result, the steering ratio is reduced, causing the pitman arm to move noticeably further for a given steering wheel movement. With the wheel turned one-half turn, the steering ratio is reduced to approximately 14.2:1.

With a three-quarter turn of the steering wheel, the leverage has been further reduced to approximately 13.3:1.

This smooth reduction in steering ratio is produced by the rolling action between the rack and center tooth that constantly shortens the effective leverage by moving the contact point down the side to the root of the long center tooth. At this time, the tip of the short tooth begins contact with the rack at the same radius and soon takes over the load.

From three-quarters to one full turn of the steering wheel the ratio continues to diminish as the same rolling action moves the point of contact from the tip to the root of the short tooth.

This action completes the ratio reduction from 13.3 to 13.1:1. For the last quarter turn of the steering wheel, the ratio remains constant at 13.1:1 to provide greatest maneuverability for backing and parking.

### MANUAL STEERING GEAR

The manual steering gear (Figs. 2-7) is of the recirculating-ball-nut type with the steering shaft, worm shaft and worm nut all in line.

The steering shaft and worm shaft are separated with a coupling which permits removal of the gear assembly or steering shaft (and column) independent of each other.

The mechanical element of this steering gear is a recirculating ball system in which steel balls act as a rolling thread between the steering worm and nut. The nut is one piece and is geared to the sector of the pitman shaft, and mounted on the worm. It is driven through the steel balls which circulate in helical grooves in both the worm and nut. Ball return guides, attached to the nut, serve to recirculate the two sets of balls.

Lash between the pitman shaft sector and rack of the ball nut is maintained by an adjusting screw through the side cover which is retained in the end of the pitman shaft (Fig. 3).

The teeth on the sector, which are an integral part of the pitman shaft, and the ball nut are so designed that a tighter fit exists between the two when the front wheels are straight ahead. Proper engagement between the sector and the ball nut is obtained by an adjusting screw which moves the pitman shaft endwise, permitting desired engagement of the tapered teeth of the ball nut and sector gear. The worm bearing adjuster can be turned to provide proper preloading of the upper and lower worm thrust bearings. For overhaul procedures see the proper Overhaul Manual .

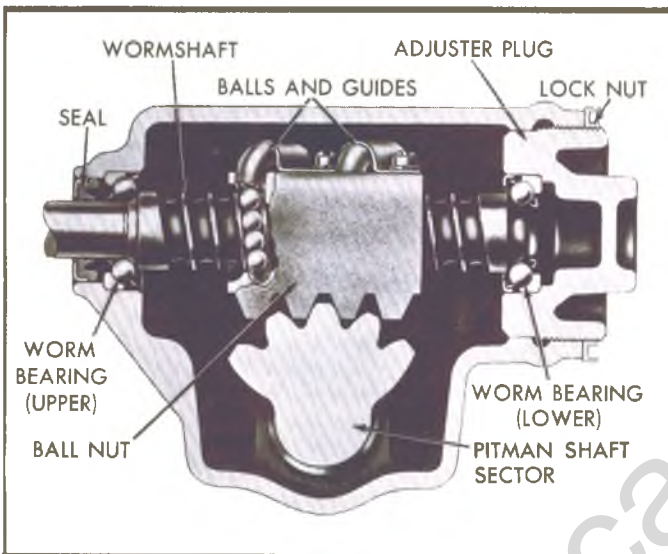

Fig. 2—Steering Gear—Typical Except G Series (Side View)

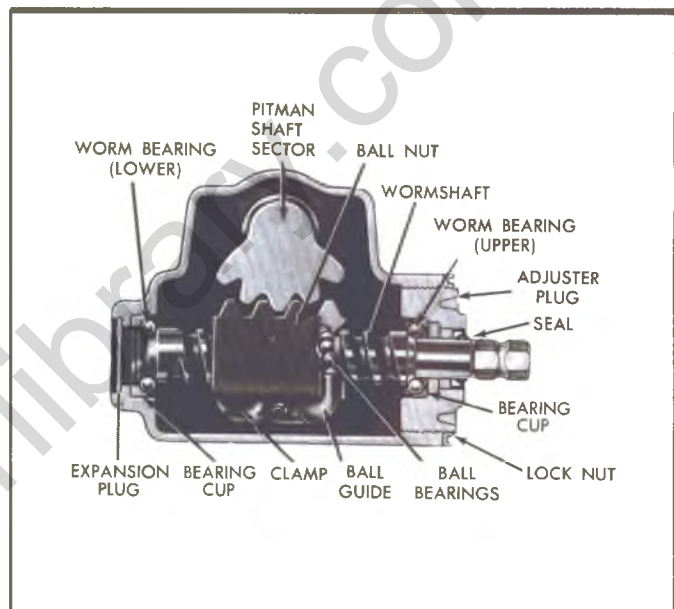

Fig. 4—Steering Gear— G Series (Side View)

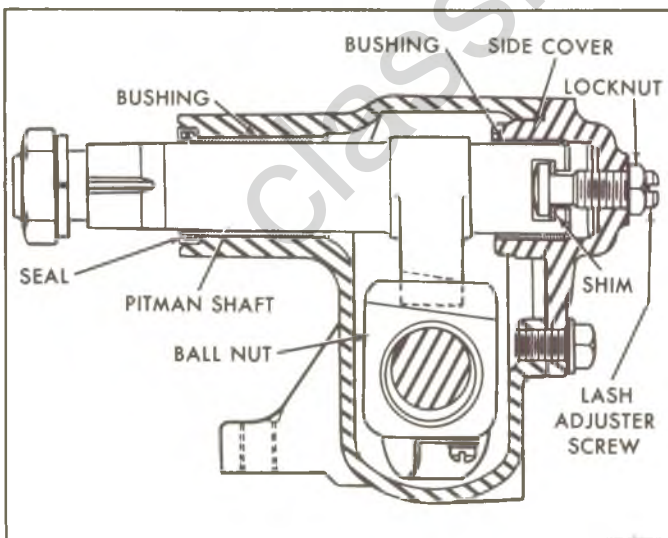

Fig. 3—Steering Gear—Typical Except G Series (End View)

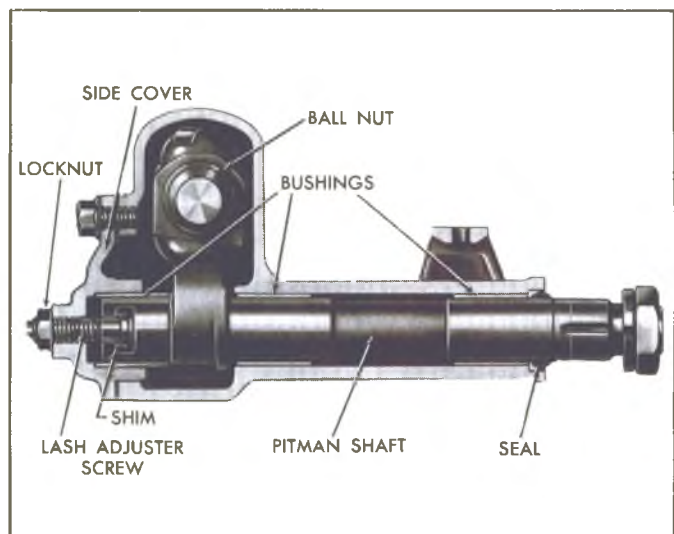

Fig. 5—Steering Gear—G Series (End View)

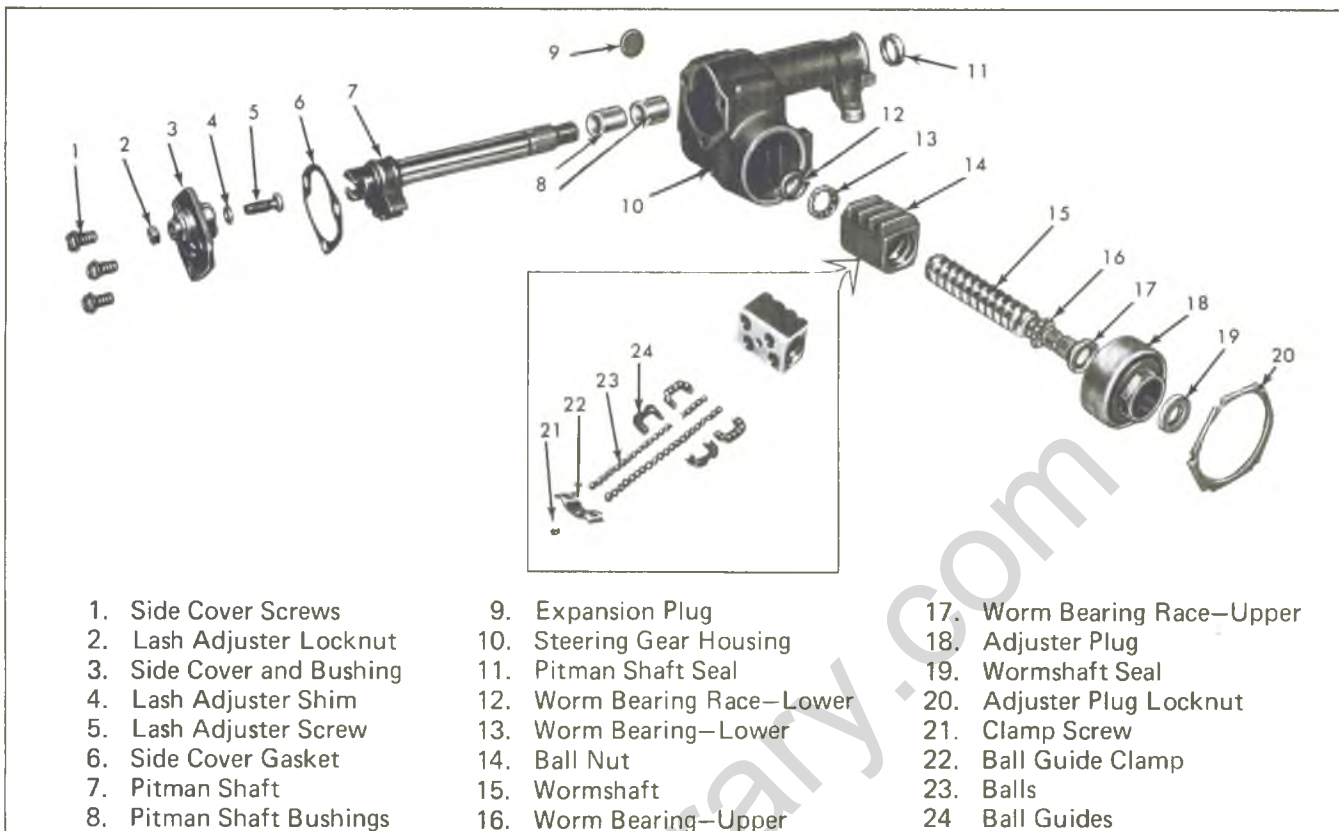

Fig. 6—Steering Gear—G Series Explode

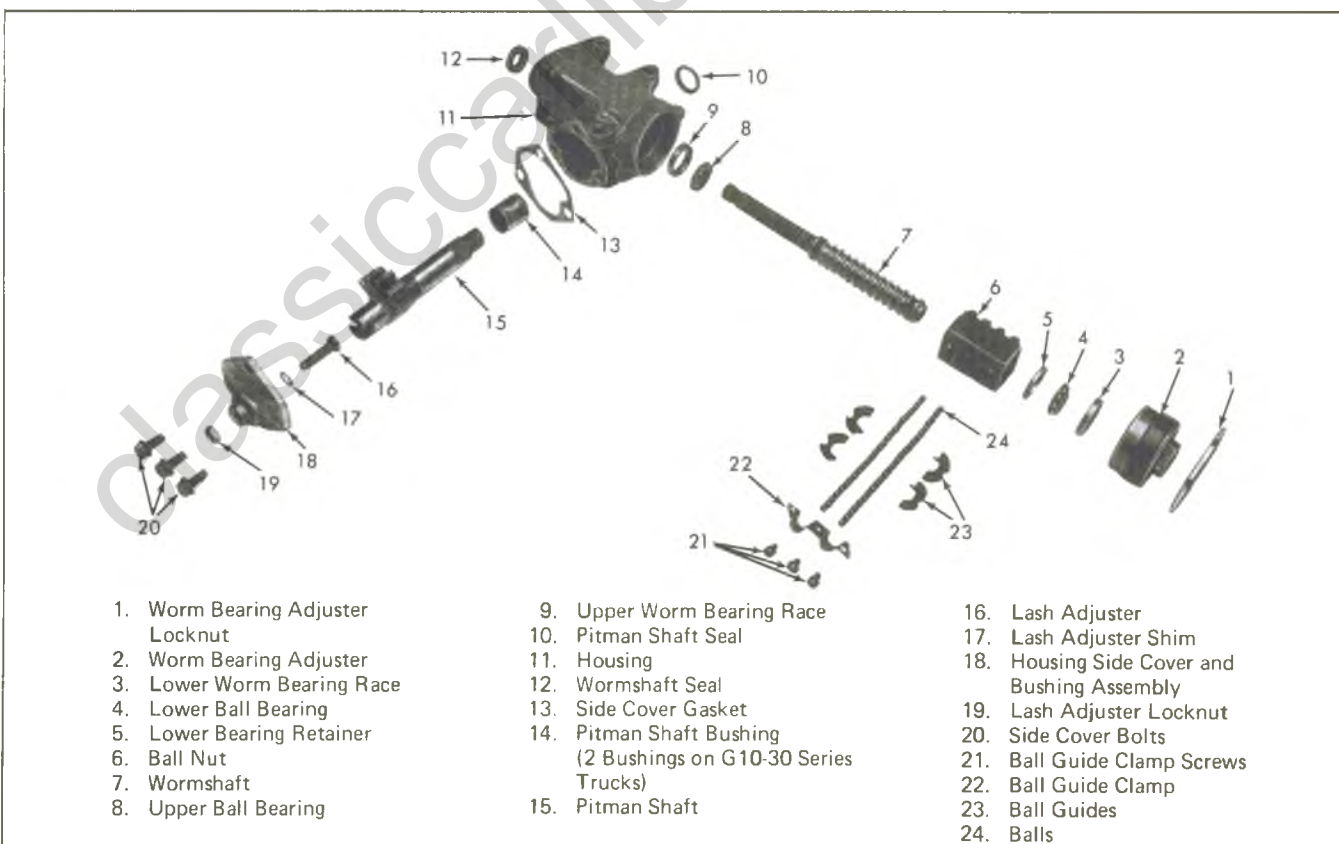

Fig. 7—Steering Gear—All Except G Series—Explode

## STEERING COLUMNS C AND K SERIES

The function locking energy absorbing steering column on C and K Series Trucks which, in addition to steering the vehicle, includes three important functions:

1. The column is energy absorbing, designed to compress up to 8.25 inches in a front-end collision to minimize the possibility of injury in the event of an accident.
2. The ignition switch and lock are mounted conveniently on the column.
3. With the automatic transmission column, the ignition, steering and gearshifting operation can be locked to inhibit theft of the vehicle.

The function locking energy absorbing steering column assembly is used on all C and K series trucks. This column is designed to compress under impact. When an vehicle is being driven, the forward movement of the vehicle and the forward movement of the driver both constitute a form of energy or force (Fig. 8). If a vehicle is involved in a frontal collision, the primary force (forward movement of the vehicle) is suddenly halted, while the secondary force (the driver) continues in the pre-collision direction. A frontal collision generally involves these two factors - the primary and the secondary forces. The secondary impact occurs if the driver is thrust forward onto the steering wheel and column.

The function locking energy absorbing column is designed to absorb these primary and secondary forces to the extent that the severity of the secondary impact is reduced. In reacting to the primary force the steering column compresses (Fig. 9), thereby reducing its tendency to move rearward. A split second later, if the driver is thrown forward and strikes the steering wheel (the secondary impact), his energy is also partially absorbed by compression characteristics of the column.

The operation of the column mounted lock (Fig. 10) is described as follows:

To start the vehicle, you insert the key in the lock, turn the unit to "start" and let the switch return to the "on" position. The "off", and "accessory" positions are also the same as in previous years, and are located in exactly the same order as they were when the unit was mounted on the instrument panel. The only thing that has changed is the lock's position and its function. By mounting the ignition lock on the column, two new features are possible.

When you engage the shift lever in "park" for automatic transmissions, and lock the ignition, the steering wheel locks and the gearshift locks. On standard transmission vehicles just the steering wheel locks.

The function locking energy absorbing column may be easily disassembled and reassembled, by following procedures in this section. The serviceman should be

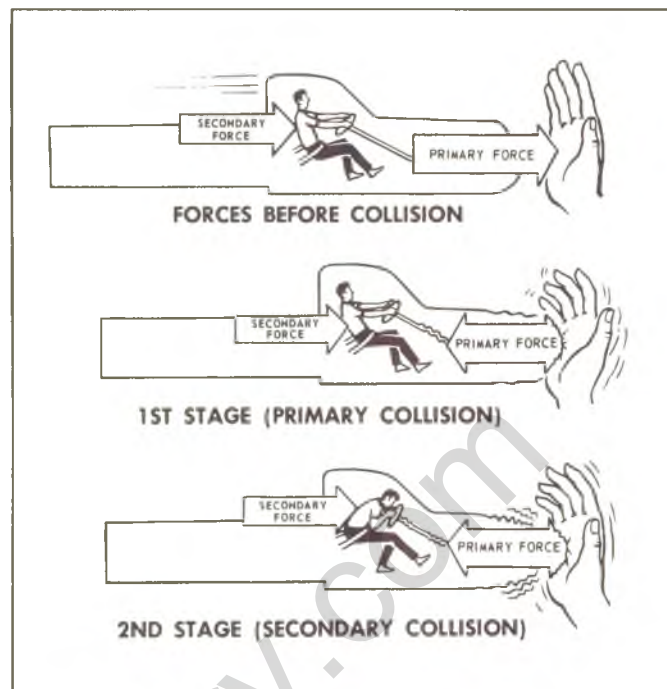

Fig. 8—Reaction of Forces During Collision

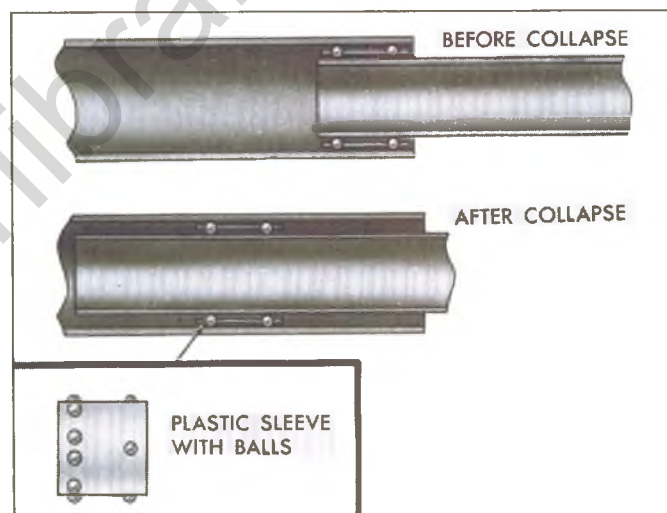

Fig. 9—Steering Column Jacket Design

aware that it is important that only the specified screws, bolts and nuts be used as designated and that they are tightened to their specified torque. This precaution will insure the energy absorbing action of the assembly. Care should be exercised **NOT** to use overlength bolts, as they may prevent a portion of the assembly from compressing under impact.

Equally as important is correct torque of bolts and nuts. Care should be taken to assure that the bolts or nuts securing the column mounting bracket to the instrument panel are torqued to the proper specification in order that the bracket will break away under impact. See the specifications section at the rear of this manual.

When the function locking energy absorbing column



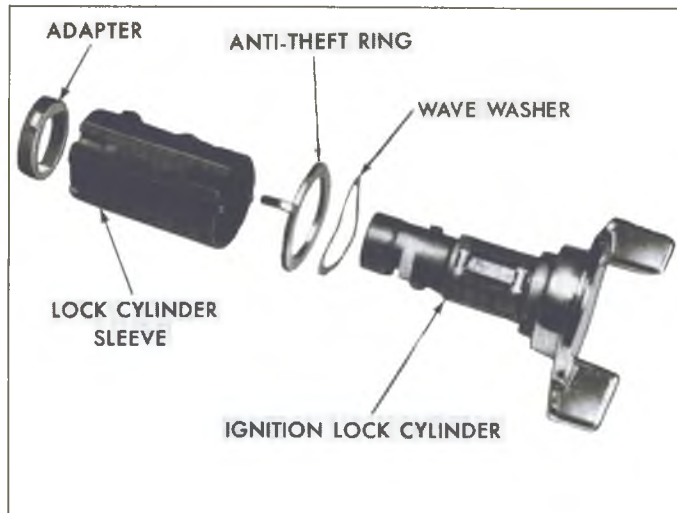

Fig. 10—Lock Cylinder Assembly

assembly is installed in a vehicle, it is no more susceptible to damage through usage than an ordinary column; however, when the column is removed, special care must be taken in handling this assembly. Only the specified wheel puller should be used. When the column is removed from the vehicle, such actions as a sharp blow on the end of the steering shaft or shift levers, leaning on the column assembly, or dropping of the assembly could shear or loosen the plastic fasteners that maintain column rigidity. It is, therefore, important that the removal and installation and the disassembly and reassembly procedures be carefully followed when servicing the assembly.

Whenever the column is removed on automatic transmission equipped vehicles, upon reinstalling the

column it will be necessary to check the neutral start switch for proper operation, and reposition if needed. A typical standard column is shown in Figure 11.

## TILT-COLUMNS

### C and K Series

The function locking energy absorbing tilt steering column option is available on all C and K series trucks (fig. 12).

The tilt function locking column is designed for ease of entry and driver comfort. Tilt columns have seven different steering wheel angle position.

The tilt mechanism consists of an upper and lower steering shaft assembly with a universal joint between them. A support assembly is held to the mast jacket by a lock plate, and a bearing housing assembly is positioned over the upper steering shaft and secured to the support by two pivot pins. Two lock shoes are pinned to the housing assembly and engage a pin in the support assembly. When the release lever is pulled up and the lock shoes disengage the support pin, the steering wheel is pushed up by a spring compressed between the support and housing assemblies.

The tilt release lever is located on the left side of the steering column and below the directional lever. The tilt lever is pulled toward the steering wheel and the wheel moved to the desired angle.

### G and P Series

A tilt column is also available for G and P (motor home) series trucks. It is the same as last years truck tilt column and all applicable service information will be found in the service section of this manual.

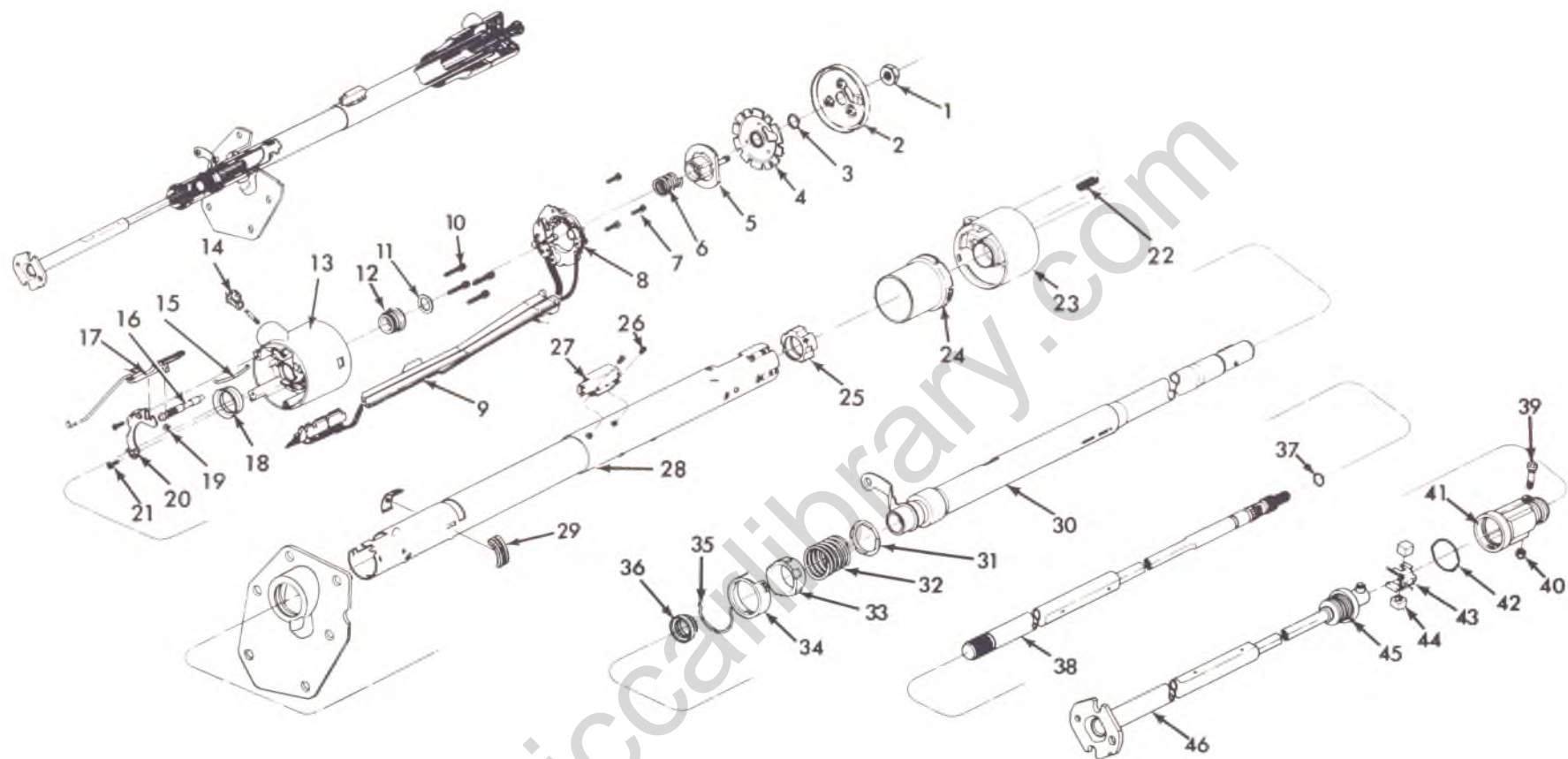
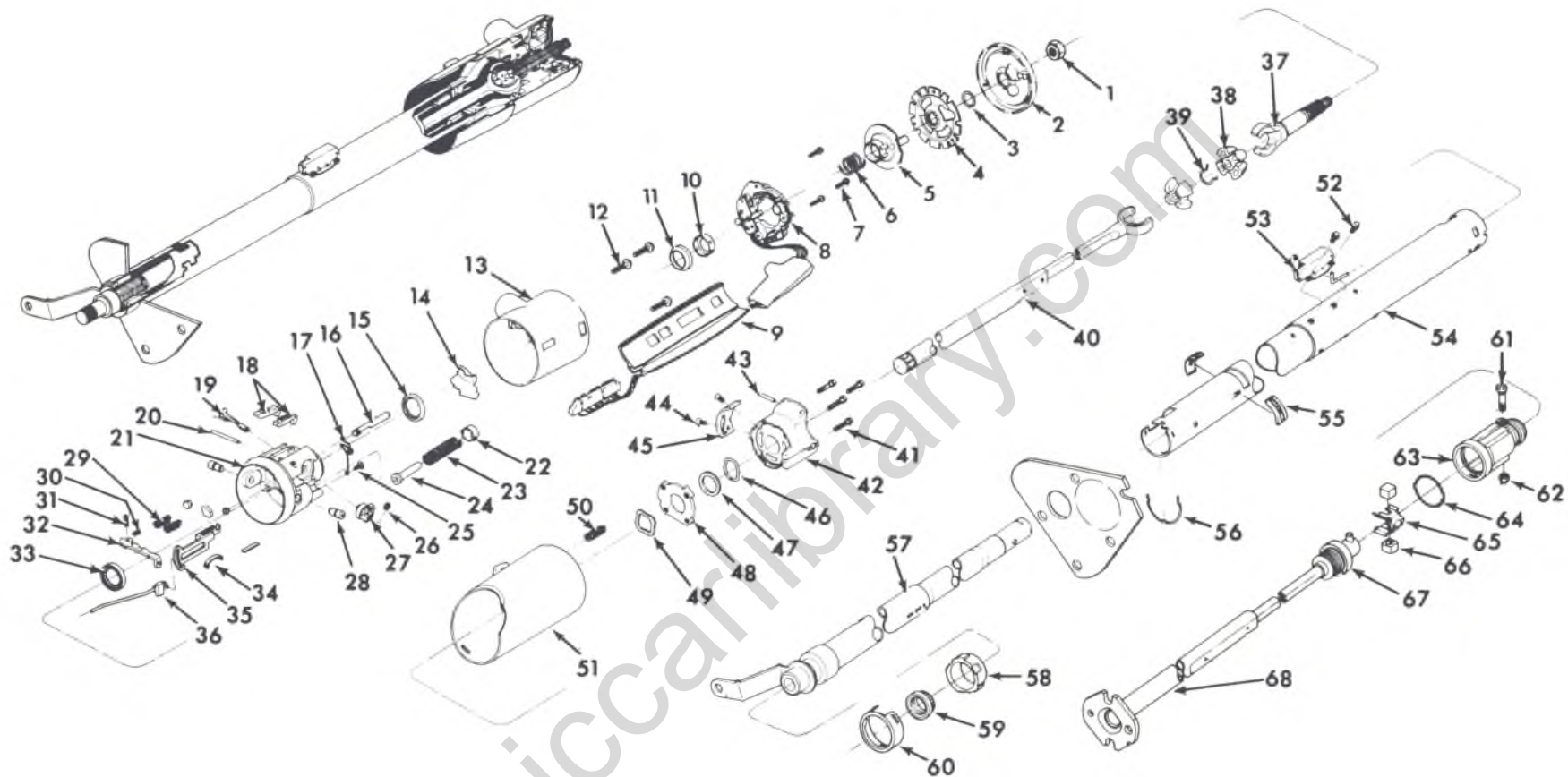

Fig. 11—Standard Column—C and K

- |                                |                                  |  |                         |
|--------------------------------|----------------------------------|--|-------------------------|
| 1. Shaft Nut                   | 12. Upper Bearing                | 24. Shift Shroud                               | 35. Retainer            |
| 2. Cover                       | 13. Turn Signal Housing          | 25. Gearshift Housing Bearing                  | 36. Lower Bearing       |
| 3. Lock Plate Retaining Ring   | 14. Ignition Switch Sector       | 26. Ignition Switch Screws                     | 37. Shaft Stop Ring     |
| 4. Lock Plate                  | 15. Switch Rack Preload Spring   | 27. Ignition Switch                            | 38. Steering Shaft      |
| 5. Cancelling Cam              | 16. Shaft Lock Bolt              | 28. Mast Jacket                                | 39. Pot Joint Bolt      |
| 6. Bearing Preload Spring      | 17. Switch Rod and Rack Assembly | 29. Neutral Safety or Back-Up Switch Retainers | 40. Nut                 |
| 7. Turn Signal Screws          | 18. Thrust Cap                   | 30. Shift Tube                                 | 41. Pot Joint Cover     |
| 8. Turn Signal Switch          | 19. Shaft Lock Bolt Washer       | 31. Thrust Spring Washer                       | 42. Seal Retaining Ring |
| 9. Protector Cover             | 20. Shift Lever Detent Plate     | 32. Shift Tube Thrust Spring                   | 43. Bearing Spring      |
| 10. Turn Signal Housing Screws | 21. Detent Plate Screws          | 33. Lower Bearing Adapter                      | 44. Bearing Blocks      |
| 11. Bearing Thrust Washer      | 22. Shift Lever Spring           | 34. Lower Bearing Reinforcement                | 45. Pot Joint Seal      |
|                                | 23. Gearshift Lever Housing      |  | 46. Intermediate Shaft  |

Fig. 12—Tilt Steering Column Assembly - C and K



- |                                |                                 |                                    |                                 |
|--------------------------------|---------------------------------|------------------------------------|---------------------------------|
| 1. Shaft Nut                   | 17. Lock Bolt Spring            | 35. Ignition Switch Rack           | 53. Ignition Switch             |
| 2. Cover                       | 18. Lock Shoes                  | 36. Ignition Switch Rod            | 54. Mast Jacket                 |
| 3. Lock Plate Retaining Ring   | 19. Sector Shaft                | 37. Upper Steering Shaft           | 55. Neutral-Safety or Back-Up   |
| 4. Lock Plate                  | 20. Lock Shoe Pin               | 38. Centering Spheres              | 56. Retainer                    |
| 5. Cancelling Cam              | 21. Bearing Housing             | 39. Center Sphere Spring           | 57. Shift Tube                  |
| 6. Bearing Preload Spring      | 22. Tilt Lever Spring Retainer  | 40. Lower Steering Shaft           | 58. Lower Bearing Adapter       |
| 7. Turn Signal Screws          | 23. Tilt Lever Spring           | 41. Bearing Housing Support Screws | 59. Lower Bearing               |
| 8. Turn Signal Switch          | 24. Tilt Lever Spring Guide     | 42. Bearing Housing Support        | 60. Lower Bearing Reinforcement |
| 9. Protector Cover             | 25. Lock Bolt Spring Screw      | 43. Pin                            | 61. Pot Joint Bolt              |
| 10. Upper Bearing Seat         | 26. Sector Snap Ring            | 44. Shift Tube Index Plate Screws  | 62. Nut                         |
| 11. Upper Bearing Race         | 27. Sector                      | 45. Shift Tube Index Plate         | 63. Pot Joint Cover             |
| 12. Turn Signal Housing Screws | 28. Bearing Housing Pivot Pins  | 46. Support Retaining Ring         | 64. Seal Retaining Ring         |
| 13. Turn Signal Housing        | 29. Shoe Release Springs        | 47. Support Thrust Washer          | 65. Bearing Spring              |
| 14. Tilt Lever Opening Shield  | 30. Spring                      | 48. Support Plate Lock             | 66. Bearing Blocks              |
| 15. Upper Bearing              | 31. Shoe Release Lever Pin      | 49. Support Wave Washer            | 67. Pot Joint Seal              |
| 16. Shaft Lock Bolt            | 32. Shoe Release Lever          | 50. Gearshift Lever Spring         | 68. Intermediate Shaft          |
|                                | 33. Lower Bearing               | 51. Gearshift Lever Housing        |                                 |
|                                | 34. Ignition Switch Rack Spring | 52. Ignition Switch Screws         |                                 |

## POWER STEERING SYSTEM

### HYDRAULICS

Hydraulics is the science of liquids, such as water or oil. When we study hydraulics, we learn that pressure can be exerted through liquids, and that this pressure can transmit motion from one place to another. The reason for this is that liquids are incompressible. That is, they cannot be compressed to a smaller volume.

### TRANSMITTING MOTION WITH LIQUIDS

Since liquid is not compressible, motion may be transmitted by liquid. For example, consider two pistons in a cylinder with a liquid between them. When the applying piston is moved into the cylinder 8 inches, then the output piston will be pushed along the cylinder the same distance. You could substitute a solid connecting rod between piston A and piston B and get the same result. But the advantage of such a system is that you can transmit motion between cylinders at any angle or distance. As the applying piston is moved, liquid is forced out of cylinder A, through the tube, and into cylinder B. This causes the output piston to move in cylinder B.

### TRANSMITTING PRESSURE WITH LIQUIDS

The pressure applied to a liquid is transmitted by the liquid in all directions and to every part of the liquid. For example, when a piston with 1 square inch of area applies a force of 100 pounds on a liquid, the pressure on the liquid is 100 psi (pounds per square inch). This pressure will be registered throughout the entire hydraulic system. If the area of the piston is 2 square inches and the piston applies a force of 100 pounds, then the pressure is only 50 psi.

With an input-output system we can determine the force

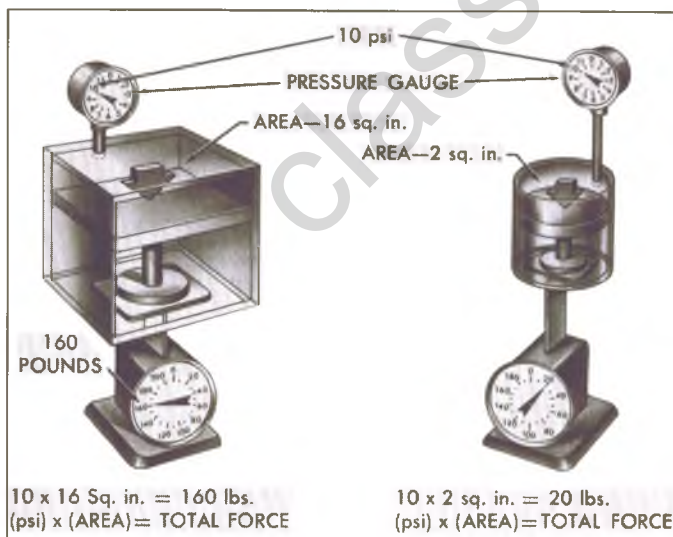

Fig. 13—Basic Hydraulic Theory

applied to any output piston by multiplying the pressure in pounds per square inch by the area of the output piston in square inches. For example, if the pressure is 10 psi, and the output piston has an area of 16 square inches, the output force on this piston is 10 times 16 or 160 pounds. If a piston has an area of 2 square inches its output force is therefore 20 pounds (10 x 2) (Fig. 13). The bigger the output piston, the greater the output force. If the area of the piston were 100 square inches, for example, the output force would be 1,000 pounds. Likewise, the higher the hydraulic pressure, the greater the output force. If the hydraulic pressure on the 2-square-inch piston went up to 1,000 psi, then the output force on the piston would be 2,000 pounds.

In all the preceding examples, a piston-cylinder arrangement was the means of producing the pressure and this is the method used in hydraulic brakes. However, any sort of pump or pressure-producing device can be used. Several types of pump (gear, rotor, vane) have been used in automatic transmissions and power steering. G.M. Power Steering uses a constant displacement vane type pump.

The hydraulic power steering system consists of a pump, an oil reservoir, a steering gear, a supply hose, and a return hose (Figs. 14-15).

The integral power steering gear may be either constant ratio or variable ratio. The integral power steering gear has an open center, rotary type, three-way control valve, which directs oil to either side of the rack piston. The

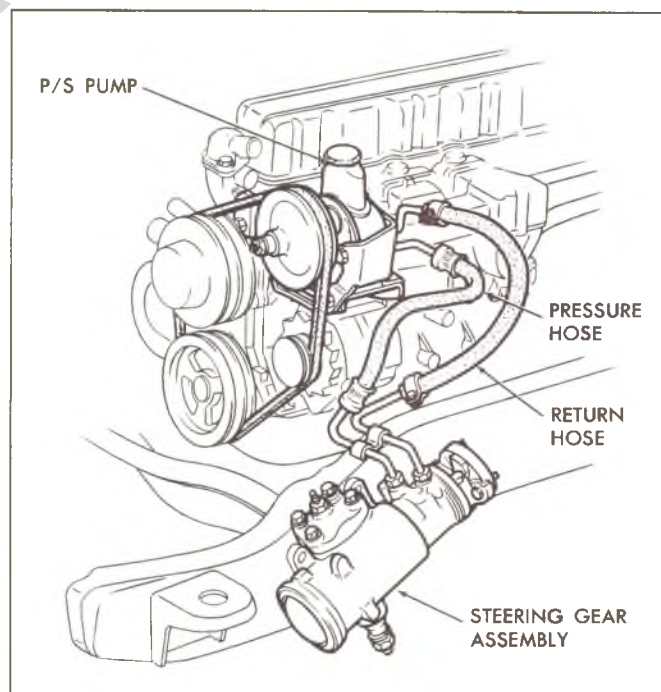

Fig. 14—Power Steering System w/L-6 Engine—  
Typical

rack piston converts hydraulic power into mechanical output. The steering gear is mounted on the left frame rail by three mounting bolts. The steering shaft is joined to the steering gear through a flexible coupling, which allows for the possibility of slight shaft to gear misalignment.

The pump is pulley driven, having an oil reservoir, which is part of the pump. It is attached to the front of the engine by a bracket, and is belt driven from the engine crankshaft.

### POWER STEERING GEAR ( Fig. 17 )

Two variations of integral power steering are used in trucks; "constant ratio" ("P" Models) and "Variable Ratio" ("C, G and K" Models).

The power steering gears are of the same general design and are overhauled in a like manner. Both gears incorporate the recirculating ball system in which steel balls act as a rolling thread between the steering wormshaft and rack-piston. The rack-piston nut is geared to the sector of the pitman shaft. The valve is contained in the gear housing thus eliminating the need for separately mounted valve and cylinder assemblies.

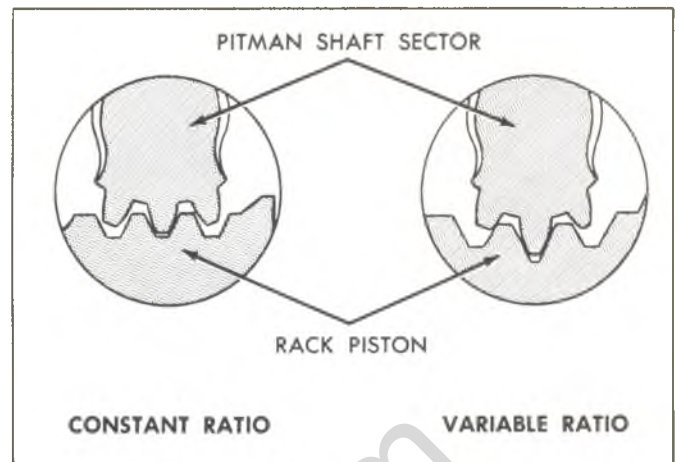

Fig. 16—Pitman Shaft Sector Teeth

All power steering gear assemblies will incorporate a new input shaft lower thrust bearing configuration. The thrust bearing itself will remain unchanged, but both thrust bearing races are conical, instead of the previous flat design, and actually become spring washers or races to prevent loss of thrust bearing preload for the life of the car.

Variable ratio steering is faster when cornering, requiring fewer turns of the steering wheel to move the front wheels

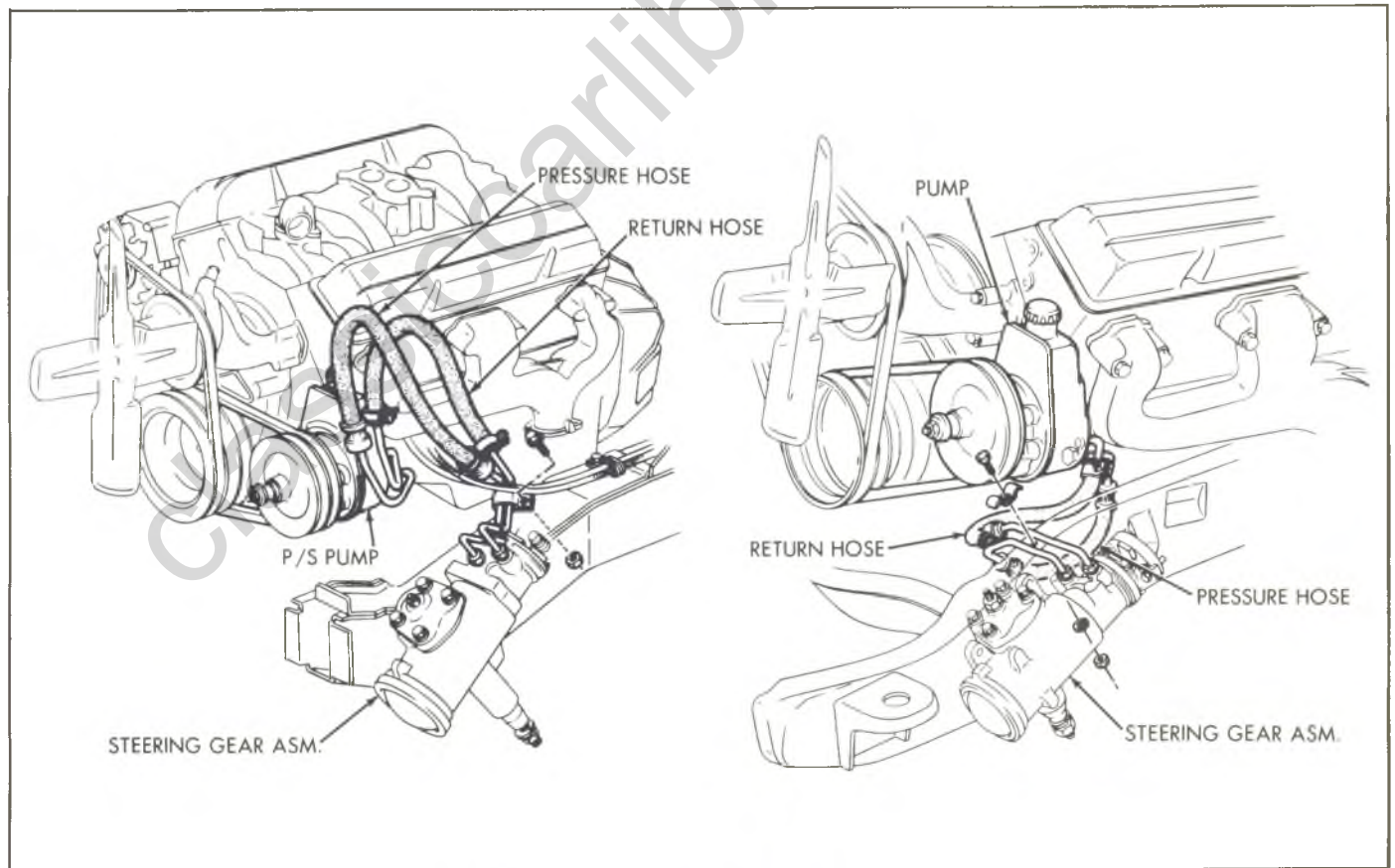

Fig. 15—Power Steering System V8—Typical

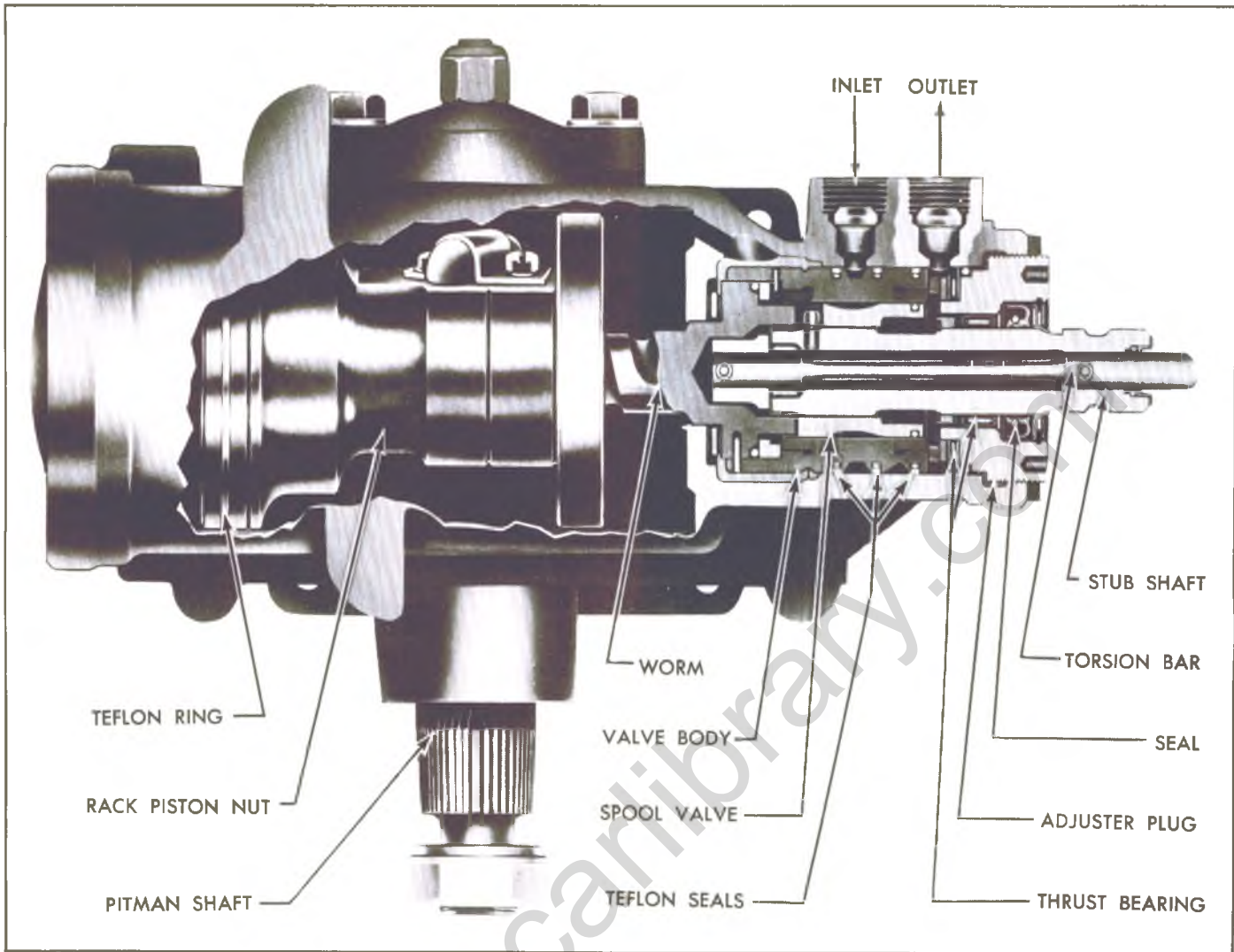

Fig. 17—Power Steering Gear—(Typical)

from stop to stop, while steering effort is not increased. It also provides more precise control and better response in maneuvering, particularly in sharp rapid turns and in parking.

Variable ratio steering is accomplished by a pitman shaft sector incorporating a short tooth on either side of a long center tooth, rather than a sector with three teeth of equal length as in the constant ratio gear (fig. 16). Companion changes are also made in the rack-piston teeth.

## OPERATION

### Neutral (Straight Ahead Position) (Fig. 19)

When turning effort is not being applied at the steering wheel, the slots in the spool valve are positioned so that oil entering the valve body from the housing pressure port passes through the slots in the spool valve to the oil return port in the housing. The chambers at both ends of the rack-piston and around the pitman shaft are always full of oil, which acts as a cushion to absorb road shock so that they are not transferred to the driver. In addition, this oil lubricates all the internal components of the gear.

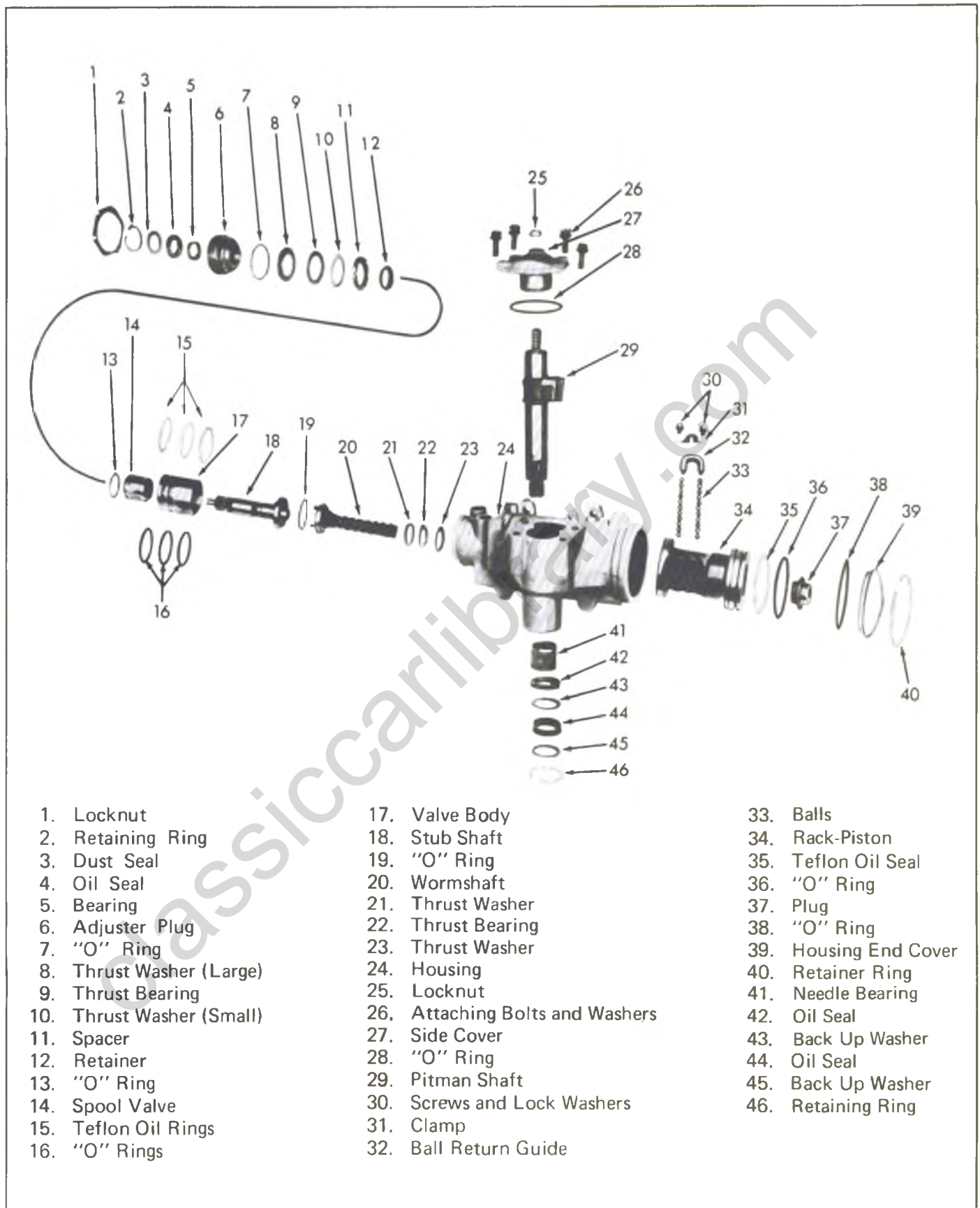

Fig. 18—Power Steering Gear—Exploded (Typical)

**Right Turn (Fig. 20)**

When the steering wheel is turned to the right, the worm resists being turned because of the resistance offered by the front wheels. The valve body also resists turning because it is pinned to the worm. Driver force exerted at the steering wheel turns the lower shaft and spool valve a slight amount in relation to the valve body because of the twisting action of the torsion bar. This slight amount of turning of the spool valve is sufficient to position the slots in the valve body and spool valve for power assist.

The right turn slots in the spool valve are closed off from the return (wide) slots in the valve body and opened more to the pressure (narrow) slots in the valve body. The left turn slots in the spool valve are closed off from the pressure slots in the valve body and opened more to the return slots in the valve body.

Pressure immediately begins to build up against the lower end of the rack-piston, forcing it upward to apply turning effort to the pitman shaft. The oil in the chamber at the upper end of the rack-piston is then forced out through the valve body and spool valve through the oil return port to the pump reservoir.

The instant the driver stops applying turning effort to the steering wheel, the spool valve is forced back into its neutral position by the torsion bar. Oil pressure on the

lower end of the rack-piston then decreases so that pressure is again equal on both sides of the rack piston and the front wheels return to the straight ahead position when the car is moving.

Under normal driving conditions, oil pressure does not exceed 200 psi except when turning corners where it does not ordinarily exceed 450 psi. Oil pressure, when parking, ranges from 900 to 1,300 psi depending upon road conditions and weight of the vehicle. The steering effort during normal driving, ranges from 1 to 2 lbs. and during parking from 2 to 3-1/2 lbs. again depending upon road conditions.

A check valve located under the high pressure connector seat hydraulically dampens the shock transmitted to the steering gear when driving on washboard roads.

**Left Turn (Fig. 21)**

When the steering wheel is turned to the left, the relationship between the spool valve slots and valve body slots is again changed through twisting of the torsion bar. Pressure immediately builds up against the upper end of the rack-piston, forcing it downward to apply turning effort to the pitman shaft. The oil in the chamber at the lower end of the rack-piston is forced out through the valve body and spool valve to the pump reservoir.

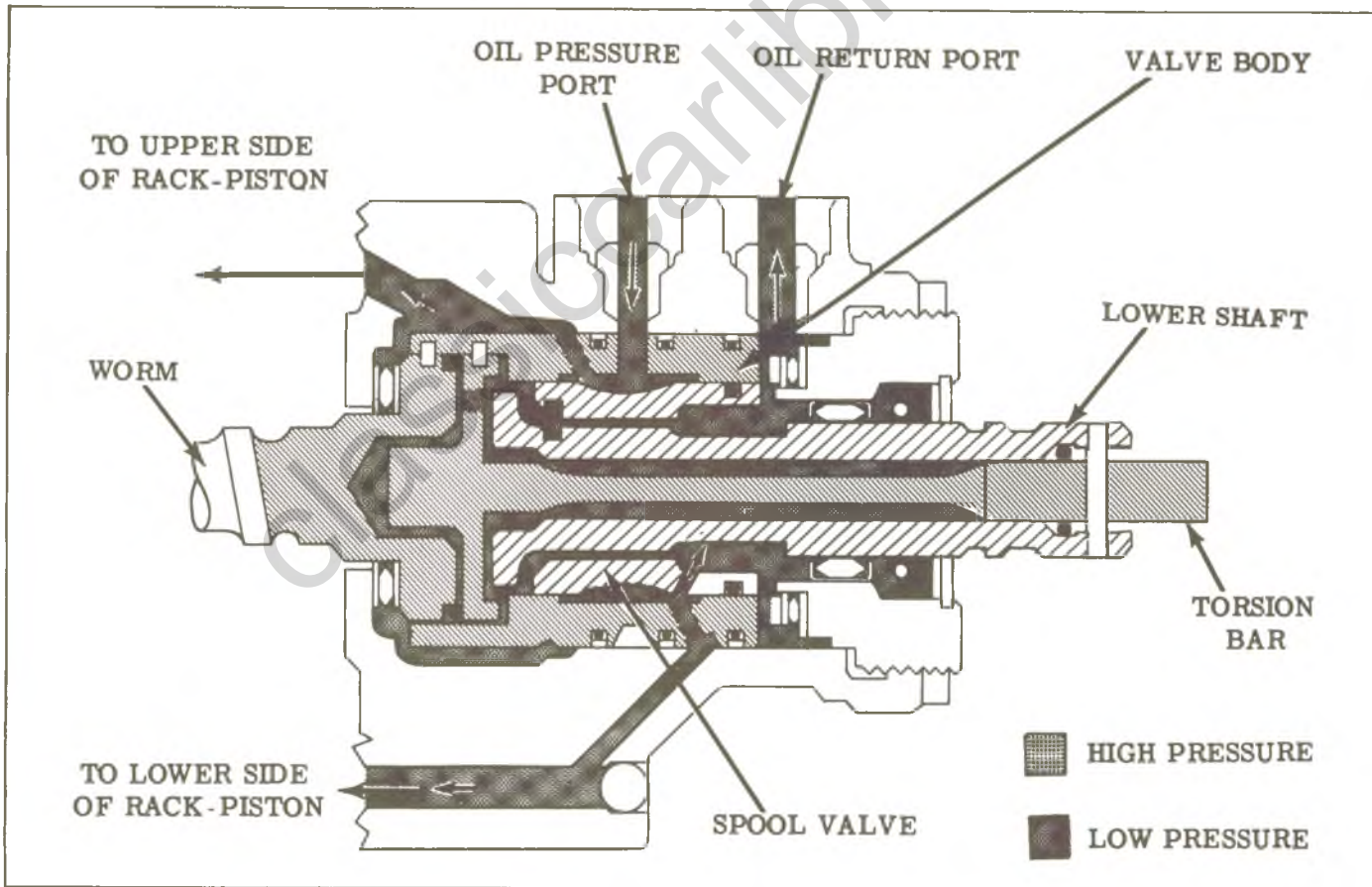

Fig. 19—Neutral Position



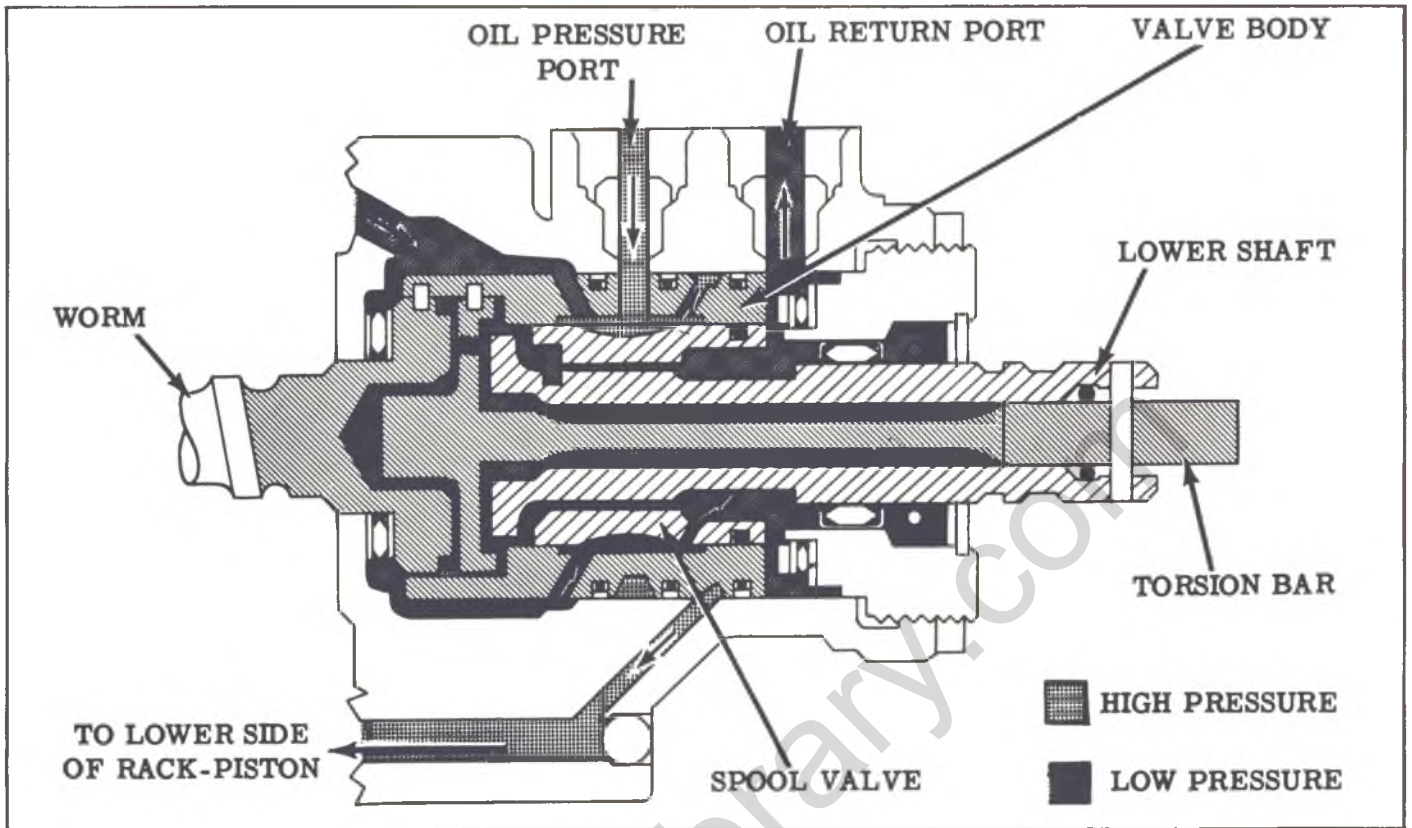

Fig. 20—Right Turn Position

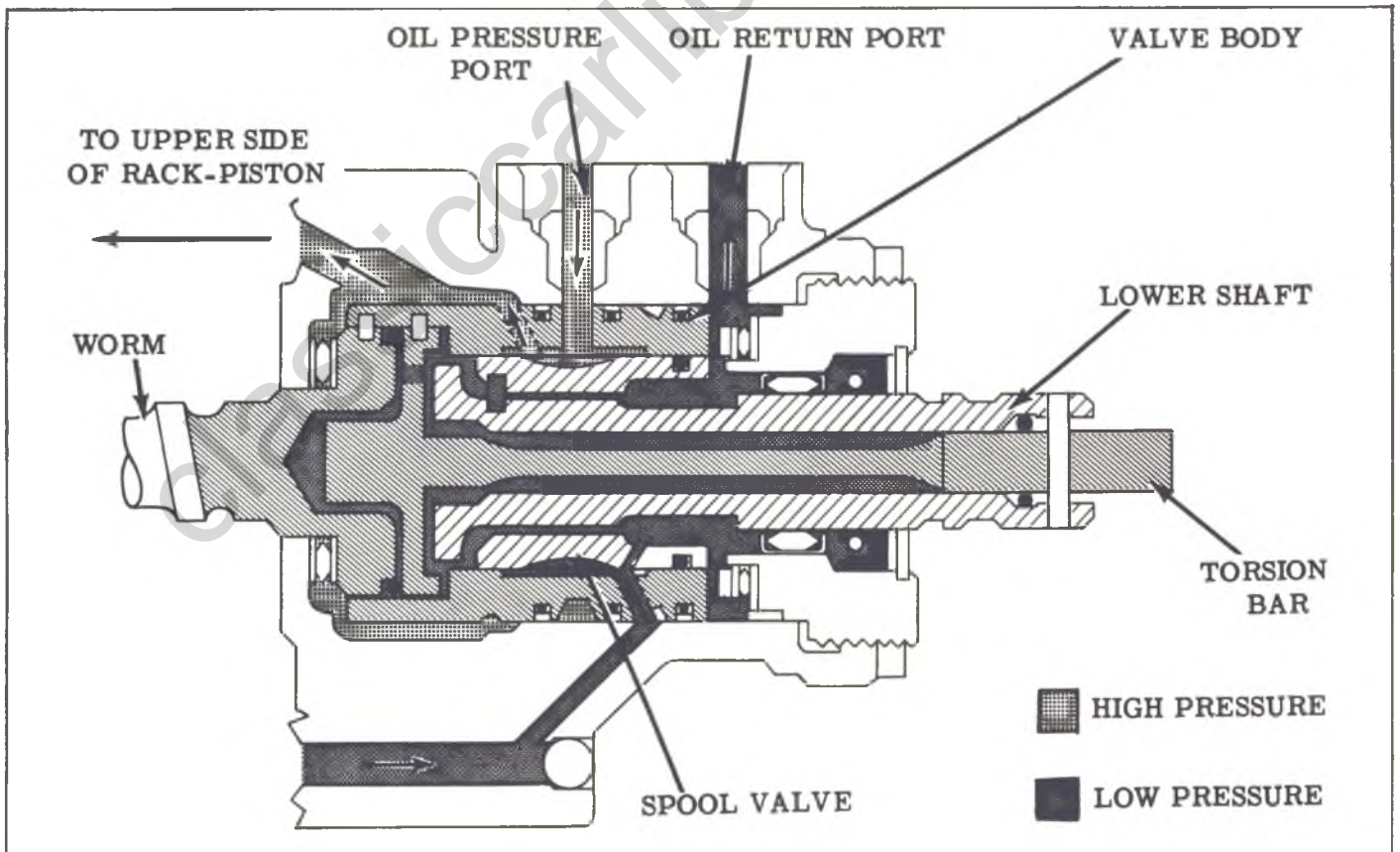

Fig. 21—Left Turn Position

## POWER STEERING PUMP

### PUMP DESCRIPTION

The housing and internal parts of the pump are inside the reservoir so that the pump parts operate submerged in oil. The reservoir is sealed against the pump housing, leaving the housing face and the shaft hub exposed. The reservoir has a filler neck fitted with a cap. A shaft bushing and seal are pressed into the housing from the front. The drive shaft is inserted through this seal and bushing. A large hole in the rear of the housing contains the functional parts; namely ring, rotor, vanes and plates. A smaller hole contains the control valve assembly and spring (Fig. 22).

The thrust plate (Fig. 22) is located on the inner face of the housing by two dowel pins. This plate has four central blind cavities for undervane oil pressure. The two outer blind cavities direct discharge oil through the two cross-over holes in the pump ring (Fig. 23), through the pressure plate, and into cavity 1 (Figs. 25, 26 and 27). The two outside indentations in the thrust plate are for intake of the oil from the suction part of the pump.

The pump ring (Fig. 23) is a plate having the mating surfaces ground flat and parallel. The center hole is a two lobed cam in which the rotor and vanes operate. The ring is placed next to the thrust plate, and located with the same dowel pins.

The pressure plate is fitted against the ring and located with the same two dowel pins. This plate has six through

ports. The four central through ports connect from cavity 1 (Figs. 25, 26 and 27) to supply undervane oil pressure. The two outer ports pass oil under discharge pressure to cavity 1. The two indentations are for oil intake from the suction part of the pump, cavity 7 (Figs. 25, 26 and 27) into the rotor.

The reservoir is for oil storage. It receives and directs the return oil back to the make-up passage of the pump.

All power steering pumps will incorporate a small disc shaped magnet attached to the pump housing (Fig. 22). The magnet will serve to collect any ferric particles which may be suspended in the oil.

The drive shaft is fitted with a pulley and is belt driven from the crankshaft. The rotor is loosely splined to the drive shaft and secured with a retaining ring. It is located centrally within the ring and between the thrust and pressure plates. The ten vanes are mounted in radial slots in the rotor (Fig. 23).

### PUMP OPERATION (Fig. 24)

The mode of operation of the power steering pump is based upon the demand of the power steering gear. The various major modes of operation are: Slow cornering, moderate to high speed straight ahead driving, and cornering against the wheel stop. The pump is designed to recognize these conditions as required by the steering gear valve and compensates for them internally.

As the drive shaft turns the rotor, the vane tips follow

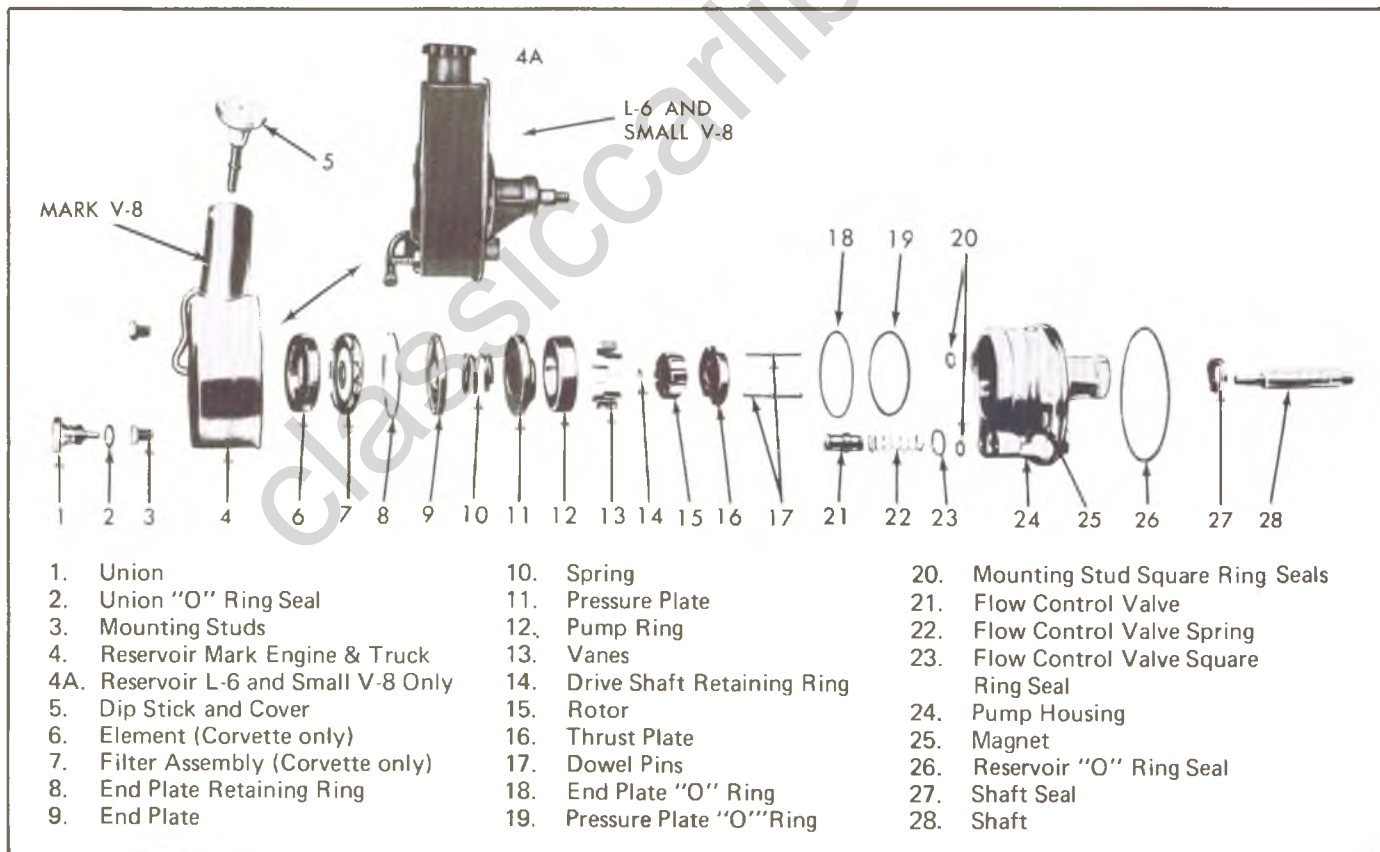

Fig. 22—Power Steering Pump—Explode

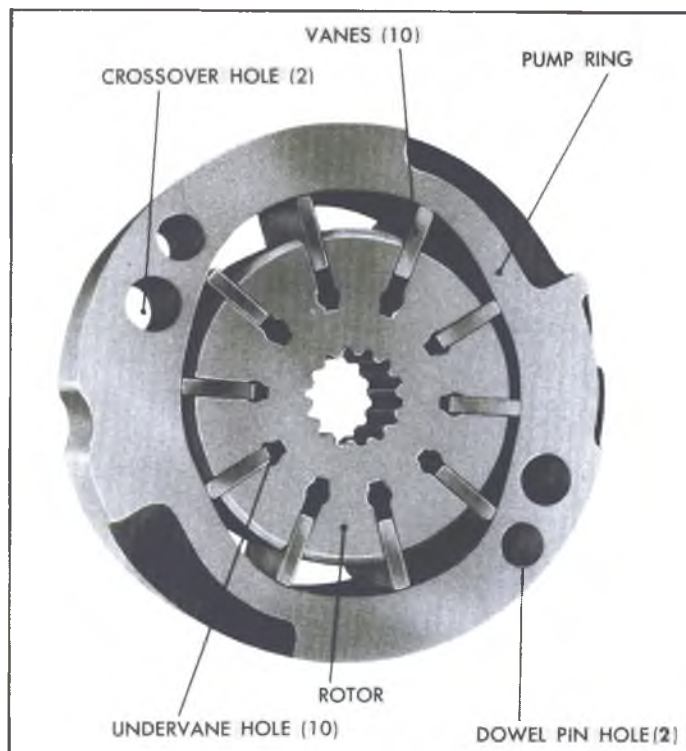

Fig. 23—Pump Components

the inner cam surface of the pump ring, moving outward and inward twice during each revolution. This results in a complete pumping cycle every 180 degrees of rotation (Fig. 23). Oil is moved in the spaces between the vanes. As the vane tips move outward, oil is sucked into the intervane spaces through four suction ports in the pressure and thrust plates. The pressure of the oil is raised, and the oil is discharged from the pump ring, as the vane tips move inward. High pressure oil discharges into cavity 1 (Figs. 25, 26 and 27), through two open ports in the pressure plate, and through two blind ports in the thrust plate, which are connected to cavity 1 by the cross-over holes in the ring. A portion of this oil is circulated through the central port system in the pressure plate, forcing the vanes to follow the cam surface of the ring. The ring-rotor leakage oil (12) is used for bushing lubrication and then bled to the reservoir.

### SLOW CORNERING (Fig. 25)

During slow cornering maneuvers, the oil pressure required will usually not exceed 400 p.s.i. The speed of the pump is not high enough to require internal bypassing of oil, therefore, the pump by-pass port to (5) remains closed. The high pressure discharge oil (7) is slightly lower in pressure than the internal high pressure oil (1). The drop in pressure occurs as oil flows through the flow control orifice (2). This lower pressure is communicated to the bottom end of the pump control valve (9) via orifice (11) and passage (8), resulting in a pressure unbalance on the valve itself. The flow control valve moves away from the discharge fitting, but due to

the force of the flow control spring (10) the valve remains closed to the bypass hole (5). The oil pressure does not build up high enough to cause the pressure relief valve to actuate, because the oil pumped through the steering gear is allowed to recirculate through the entire system.

### MODERATE TO HIGH SPEED OPERATION (Fig. 26)

When operating at moderate to high speed, it is desirable to limit the temperature rise of the oil. This is done by flow controlling. The control valve in the steering gear is an open center rotary valve. When this valve is in the straight ahead position, oil flows from the pump through the open center valve and back to the pump reservoir without traveling through the power cylinder. When this flow exceeds the predetermined system requirements, oil is bypassed within the pump. This is accomplished by the pressure drop which occurs across the flow control orifice (2). The pressure is reduced at the bottom of the flow control valve (9) via orifice (11) and passage (8). The pressure unbalance on the valve is sufficient to overcome the force of the spring (10), allowing the valve to open the bypass hole (5), and diverting oil into the intake chamber (6). Supercharging of the intake chamber occurs under these conditions. Oil at high velocity discharging past the valve into the intake chamber picks up make-up oil at hole (4) from the reservoir on the jet pump principle. By reduction of velocity, velocity energy is converted into supercharge pressure in cavity (6). During this straight ahead driving condition, the discharge pressure should not exceed 100 p.s.i.

### CORNERING AGAINST WHEEL STOPS (Fig. 27)



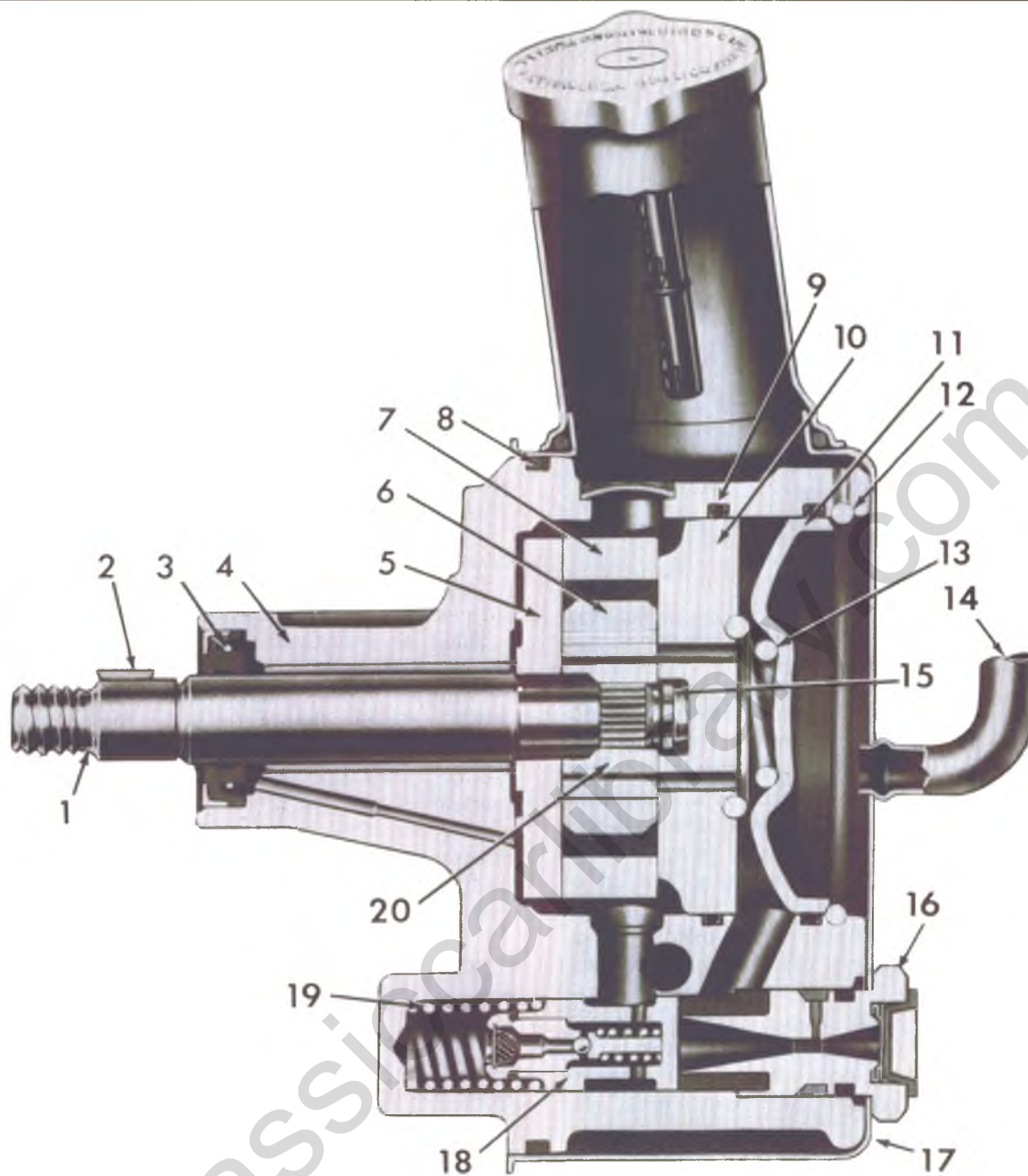

When the steering gear control valve is actuated in either direction to the point of cut-off, the flow of oil from the pump is blocked. This condition occurs when the front wheels meet the wheel stop, or when the wheel movement is otherwise blocked by a curb or deep sand or mud. The pump is equipped with a pressure relief valve. The relief valve is contained inside the flow control plunger (13). When the pressure exceeds a predetermined pressure, (greater than maximum system requirements) the pressure relief ball (14) opens, allowing a small amount of oil to flow into the bypass hole (5). This flow of oil passing through the pressure relief orifice (11) causes a pressure drop and resulting lower pressure on the bottom end of the control valve (9).

The pressure unbalance then causes the valve to compress the spring (10) allowing the major portion of the oil to bypass into the intake chamber (from 3 to 6) in the same manner as is accomplished by flow controlling. Relief pressures are usually between 900 and 1500 p.s.i. depending on the vehicle requirements.



- |                            |   |
|----------------------------|---|
| 1. Shaft                   | 12. End Plate Retaining Ring            |
| 2. Woodruff Key            | 13. Pressure Plate Spring               |
| 3. Shaft Seal              | 14. Pump Inlet Tube                     |
| 4. Pump Housing            | 15. Rotor-to-Drive Shaft Retaining Ring |
| 5. Thrust Plate            | 16. Pump Outlet Union                   |
| 6. Vanes                   | 17. Reservoir                           |
| 7. Pump Ring               | 18. Flow Control Valve                  |
| 8. Reservoir "O" Ring Seal | 19. Flow Control Valve Spring           |
| 9. Pressure Plate "O" Ring | 20. Rotor                               |
| 10. Pressure Plate         |   |
| 11. End Plate              |   |



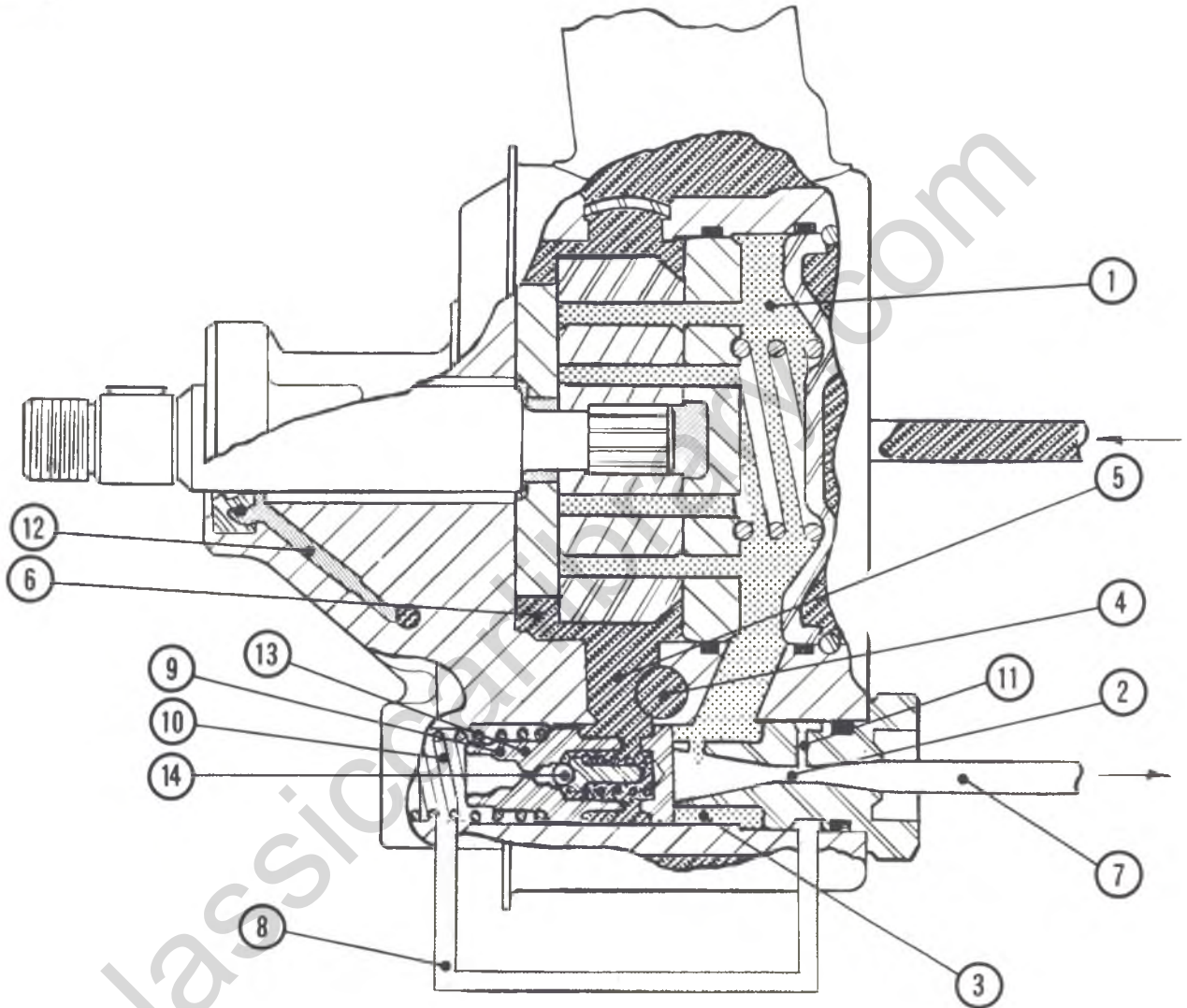

Fig. 24—Power Steering Pump—Typical

-  HIGH PRESSURE DISCHARGE
-  INTERNAL HIGH PRESSURE
-  RESERVOIR AND RETURN OIL
-  RING, ROTOR LEAKAGE OIL



- |  |  |
|--|--|
| 1. PUMP MAIN CAVITY                          | 8. PUMP CONTROL VALVE PASSAGE                                |
| 2. FLOW CONTROL ORIFICE                      | 9. PUMP CONTROL VALVE  |
| 3. INTAKE CHAMBER                            | 10. FLOW CONTROL SPRING                                      |
| 4. MAKE-UP OIL HOLE                          | 11. PUMP CONTROL VALVE ORIFICE<br>OR PRESSURE RELIEF ORIFICE |
| 5. BY-PASS PORT                              | 12. RING ROTOR LEAKAGE OIL                                   |
| 6. INTAKE CHAMBER<br>DURING FLOW CONTROLLING | 13. FLOW CONTROL PLUNGER                                     |
| 7. HIGH PRESSURE DISCHARGE<br>OIL            | 14. PRESSURE RELIEF BALL                                     |



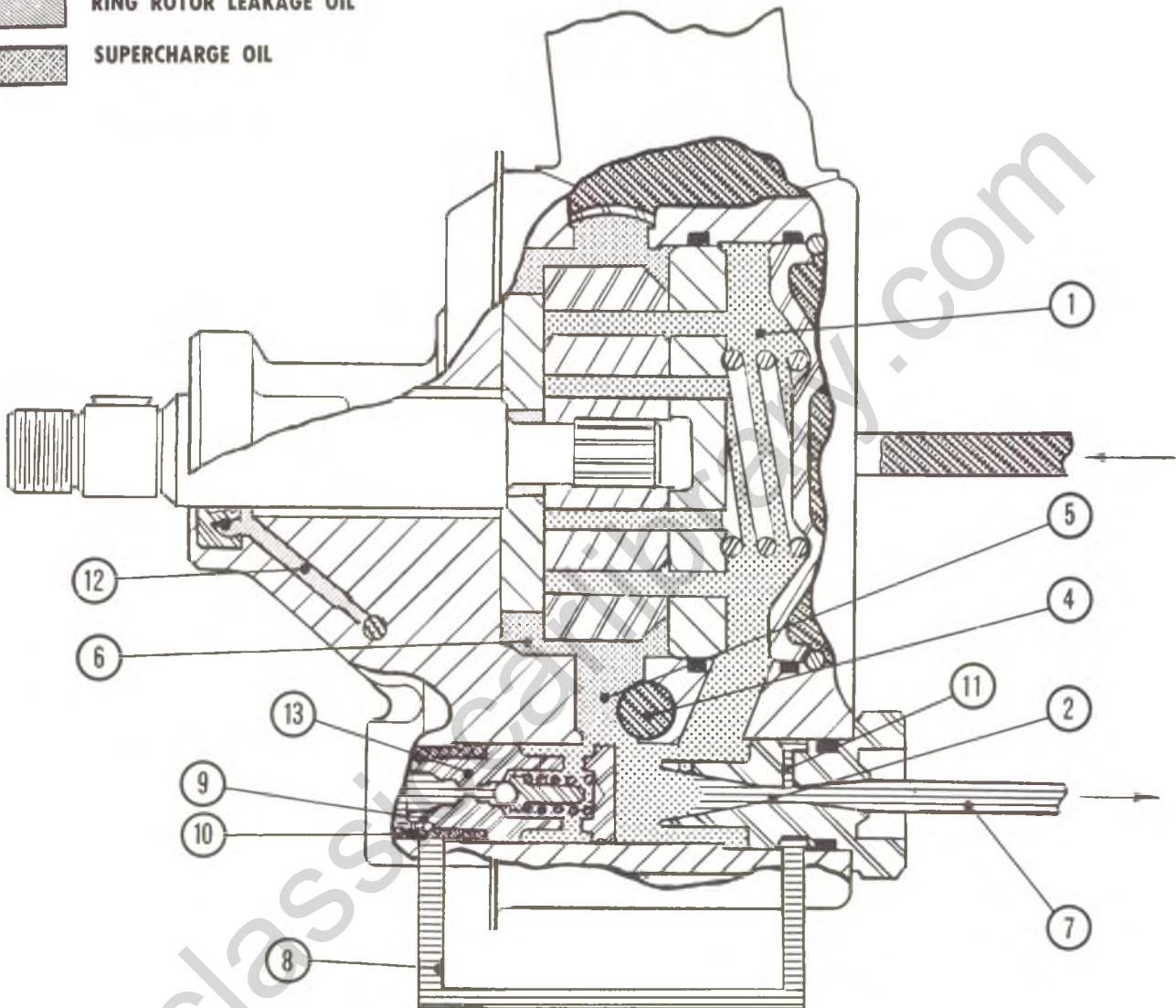

Fig. 25—Pump Flow During Slow Cornering

-  INTERNAL LOW PRESSURE OIL
-  LOW PRESSURE DISCHARGE OIL
-  RESERVOIR AND RETURN OIL
-  RING ROTOR LEAKAGE OIL
-  SUPERCHARGE OIL



- |  |  |
|--|--|
| 1. PUMP MAIN CAVITY                          | 8. PUMP CONTROL VALVE PASSAGE                                |
| 2. FLOW CONTROL ORIFICE                      | 9. PUMP CONTROL VALVE  |
| 3. INTAKE CHAMBER                            | 10. FLOW CONTROL SPRING                                      |
| 4. MAKE-UP OIL HOLE                          | 11. PUMP CONTROL VALVE ORIFICE<br>OR PRESSURE RELIEF ORIFICE |
| 5. BY-PASS PORT                              | 12. RING ROTOR LEAKAGE OIL                                   |
| 6. INTAKE CHAMBER<br>DURING FLOW CONTROLLING | 13. FLOW CONTROL PLUNGER                                     |
| 7. HIGH PRESSURE DISCHARGE<br>OIL            | 14. PRESSURE RELIEF BALL                                     |

Fig. 26—Pump During Flow Controlling (Moderate to High Speed Operation)

-  INTERNAL AND DISCHARGE HIGH PRESSURE OIL
-  PRESSURE RELIEF ORIFICE OIL FLOW
-  RESERVOIR AND RETURN OIL
-  RING, ROTOR LEAKAGE OIL
-  SUPERCHARGE OIL

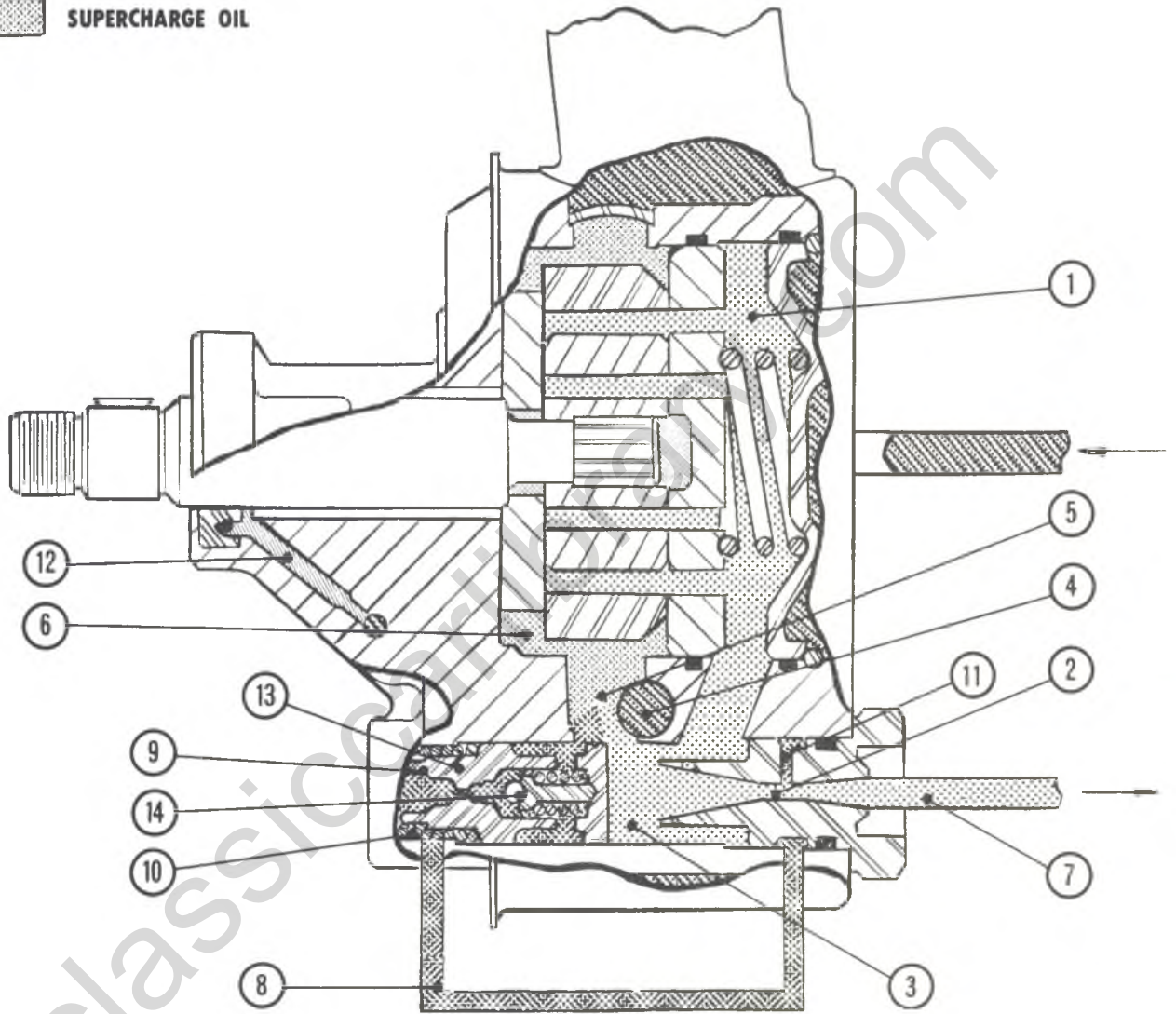

- |  |  |
|--|--|
| 1. PUMP MAIN CAVITY                          | 8. PUMP CONTROL VALVE PASSAGE                                |
| 2. FLOW CONTROL ORIFICE                      | 9. PUMP CONTROL VALVE  |
| 3. INTAKE CHAMBER                            | 10. FLOW CONTROL SPRING                                      |
| 4. MAKE-UP OIL HOLE                          | 11. PUMP CONTROL VALVE ORIFICE<br>OR PRESSURE RELIEF ORIFICE |
| 5. BY-PASS PORT                              | 12. RING ROTOR LEAKAGE OIL                                   |
| 6. INTAKE CHAMBER<br>DURING FLOW CONTROLLING | 13. FLOW CONTROL PLUNGER                                     |
| 7. HIGH PRESSURE DISCHARGE<br>OIL            | 14. PRESSURE RELIEF BALL                                     |

Fig. 27—Pump Flow During Pressure Relief (Cornering Against Wheel Stops)

## STEERING LINKAGE

In order to steer a vehicle, the wheels of the vehicle must be changed from their straight-ahead position.

The Ackerman system is used in most vehicles. For this method of steering, the front wheels are mounted on pivoted knuckles, and a steering linkage is used to tie the knuckles together so that the wheels rotate together about their pivots.

The center of rotation of a vehicle is the intersection of lines drawn perpendicular to the wheels (fig. 28). The purpose of the steering linkage is to turn the wheels while keeping this exact geometrical relationship which is necessary for minimum tire wear while turning. With the Ackerman system the front wheels do not turn equal amounts. One turns slightly more than the other so the geometrical center of rotation can be kept constant.

The problems the steering linkage encounters are keeping the geometrical relationship as well as moving with the front suspension (fig. 28). Presently all trucks except K series incorporate designs that are of the parallelogram type (fig. 29).

The basic parallelogram type linkage is made with five major components: Two adjustable tie rods, one relay

rod, one pitman arm and one idler arm. The adjustable tie rods have both left and right hand threads to allow for toe-in adjustment. The pitman arm and the idler arm are connected to the gear and frame respectively, and both are connected to the center link, or relay rod. As the steering wheel is turned, the gear rotates the pitman arm which forces the relay rod to one side. The relay rod, which is connected to the tie rods, moves the wheels which are pivoted on the control arms.

All K series vehicles use a FORE-AFT and CROSS STEER linkage which consists of an adjustable connecting rod, steering arm and a tie rod which connects the two steering knuckles together.

The tie rod joints in the steering linkage system require multi-axis motion (similar to your shoulder joint). This is accomplished by a ball and socket joint referred to as a tie rod socket or tie rod end. These joints allow the tie rod to follow the steering arm as the wheel is turned and as the suspension moves with road shock, while the joints connecting the idler and pitman arms to the relay rod often allow motion about a pivot in one plane only (similar to door hinge). In summation, as the pitman arm moves, it moves the relay rod. The tie rods, that are connected to the relay rod by ball studs, transmit the steering force to the wheels. Figure 30-32 shows the present steering linkages used on all series trucks.

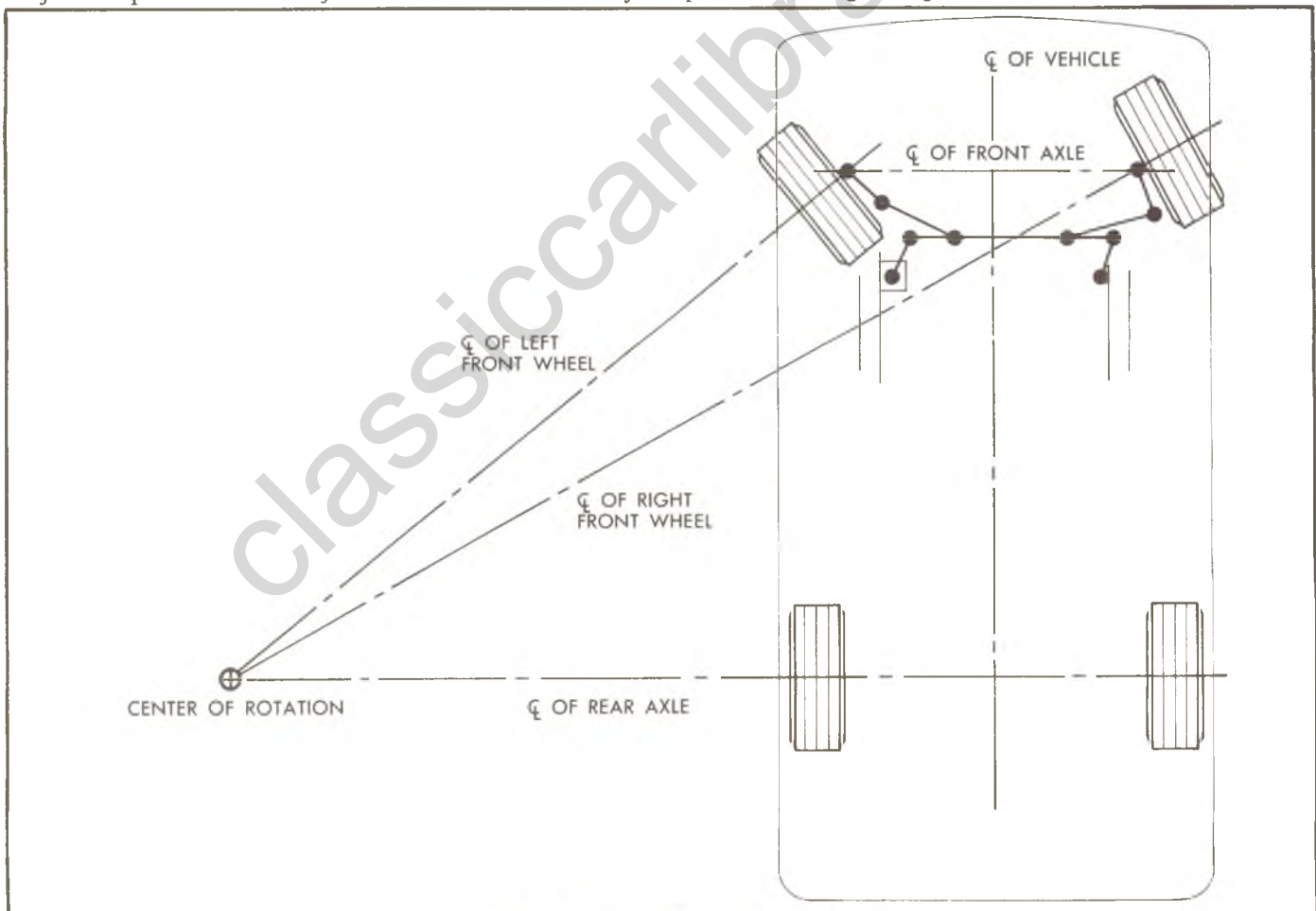

Fig. 28—Geometric Center of Rotation



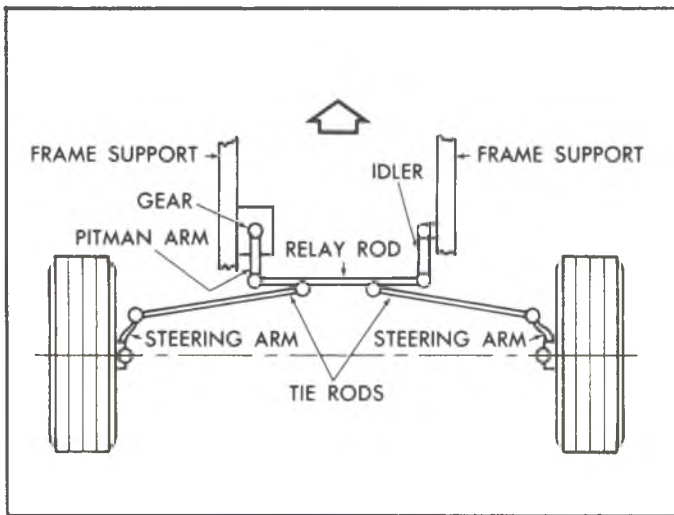

Fig. 29—Parallelogram Linkage—Front

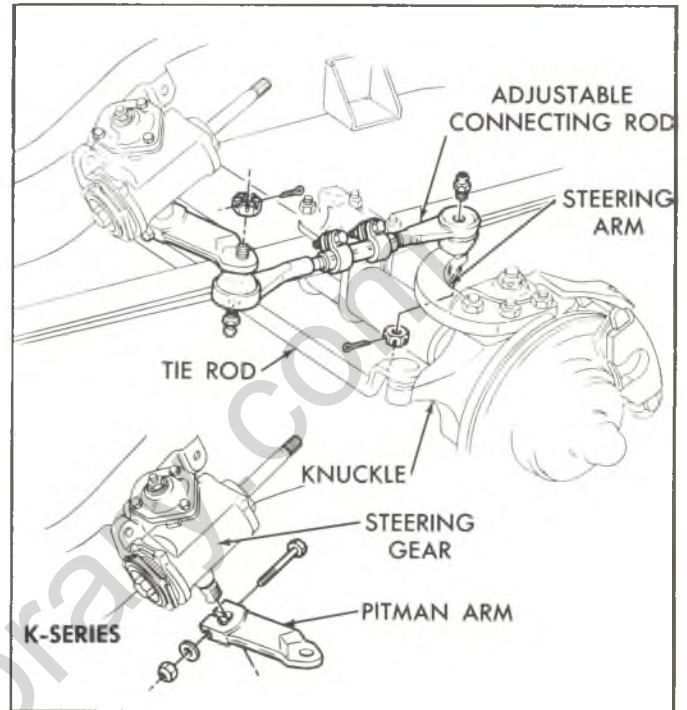

Fig. 31—Steering Linkage K Series - Typical

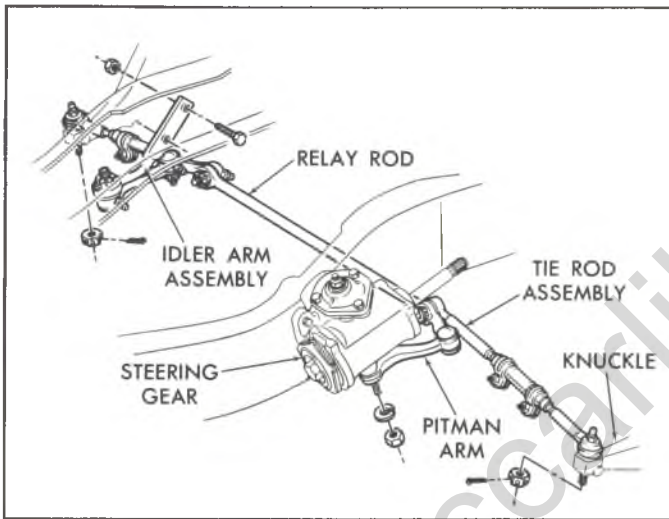

Fig. 30—Steering Linkage C, G and P Series Typical

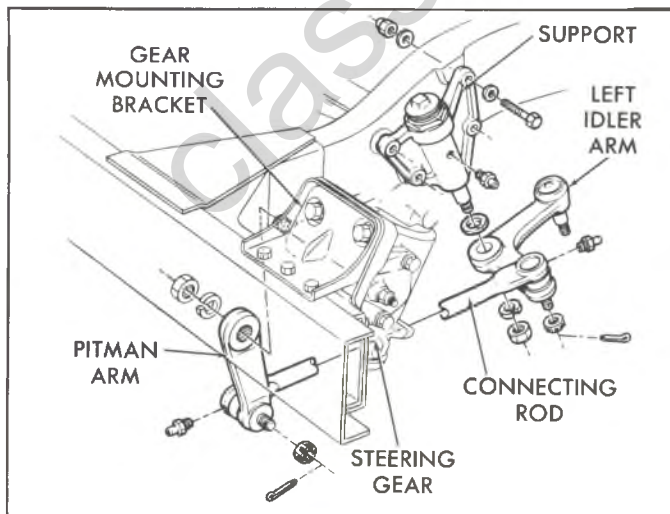

Fig. 32A—Connecting Rod and Pitman Shaft—Motor Home—Typical

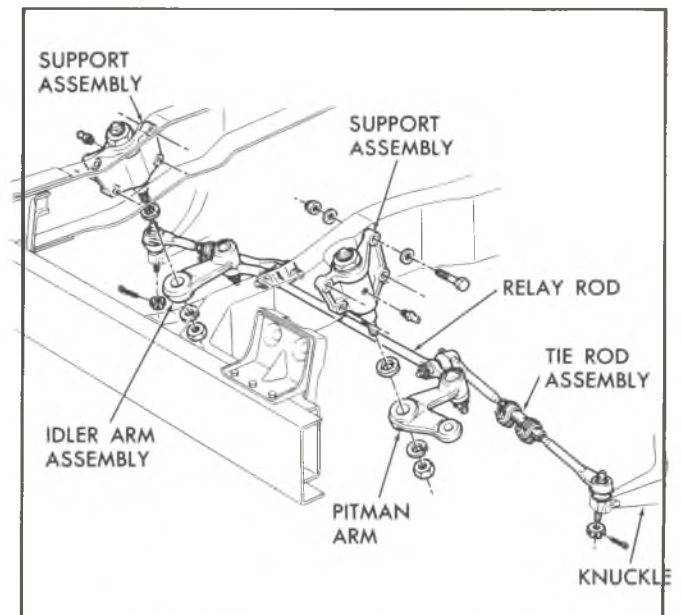

Fig. 32B—Steering Linkage Motor Home—Typical

## MAINTENANCE AND ADJUSTMENTS

### LUBRICATION

The manual steering gear is factory-filled with steering gear lubricant. Seasonal change of this lubricant should not be performed and the housing should not be drained - **no lubrication is required for the life of the steering gear.**

Every 36,000 miles, the manual gear should be inspected for seal leakage (**actual solid grease - not just oily film**). If a seal is replaced or the gear is overhauled, the gear housing should be refilled with #1051052 (13 oz. container) Steering Gear Lubricant which meets GM Specification GM 4673M, or its equivalent.

**NOTE:** Do not use EP Chassis Lube, which meets GM Specification GM 6031M, to lubricate the gear. **DO NOT OVER-FILL** the gear housing.

The steering linkage under normal conditions should be lubricated with any water resistant EP type chassis lubricant every 6,000 miles or four months, whichever occurs first. Lubricate every 3,000 miles or two months whichever occurs first when operating in dusty or muddy conditions or if the vehicle is used "off-road". Lubrication points and additional information on the chassis lubricant recommended can be found in Section 0--General Information and lubrication.

### ADJUSTMENTS

**CAUTION:** See *Caution on page one of this section regarding the fasteners referred to in steps 9d and 10.*

#### Manual Steering Gear

**CAUTION:** See *CAUTION on page 1 of this section regarding the fastener referred to in step 10.*

Before any adjustments are made to the steering gear attempt to correct complaints of loose or hard steering, or other wheel disturbances, a careful check should be made of front end alignment, shock absorbers, wheel balance and tire pressure for possible steering system problems. See Diagnosis in sections 3 and 9.

Correct adjustment of steering gear is very important. While there are but two adjustments to be made, the following procedure must be followed step-by-step in the order given.

1. Disconnect the battery ground cable.
2. Raise the vehicle.
3. Remove the pitman arm nut. Mark the relationship of the pitman arm to the pitman shaft. Remove the pitman arm with Tool J-6632 or J-5504 as shown in Figure 48.
4. Loosen the steering gear adjuster plug locknut and back the adjuster plug off 1/4 turn (fig. 33).

5. Remove the horn shroud or button cap.
6. Turn the steering wheel gently in one direction until stopped by the gear; then turn back one-half turn.

**CAUTION:** Do not turn the steering wheel hard against the stops when the steering linkage is disconnected from the gear as damage to the ball guides could result.

7. Measure and record "bearing drag" by applying a torque wrench with a socket on the steering wheel nut and rotating through a 90° arc (fig. 34).

**NOTE:** Do not use a torque wrench having a maximum torque reading of more than 50 inch pounds.

8. Adjust "thrust bearing preload" by tightening the adjuster plug until the proper "thrust loading preload" is obtained (See specifications section at rear of this manual). When the proper preload has been obtained, tighten the adjuster plug locknut to specifications and recheck torque. If the gear feels "lumpy" after adjustment, there is probably damage in the bearings due to severe impact or improper adjustment; the gear must be disassembled and inspected for replacement of damaged parts.
9. Adjust "over-center preload" as follows:
  - a. Turn the steering wheel gently from one stop all the way to the other carefully counting the total number of turns. Turn the wheel back exactly half-way, to center position.
  - b. Turn the lash adjuster screw clockwise to take out all lash between the ball nut and pitman shaft sector teeth and then tighten the locknut.
  - c. Check the torque at the steering wheel, taking

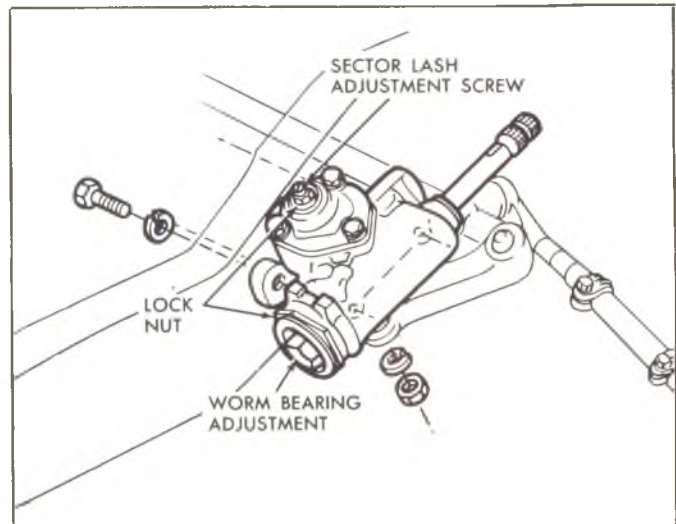

Fig. 33—Steering Gear Adjustment Points - Typical

the highest reading as the wheel is turned through center position. See the Specifications Section for proper over-center preload.

- d. If necessary, loosen locknut and readjust lash adjuster screw to obtain proper torque. Tighten the locknut to specifications and again check torque reading through center of travel.

**NOTE:** If maximum specification is exceeded, turn lash adjuster screw counter-clockwise, then come up on adjustment by turning the adjuster in a clockwise motion.

10. Reassemble the pitman arm to the pitman shaft, lining up the marks made during disassembly. Torque the pitman shaft nut to specifications.

**CAUTION:** *If a clamp type pitman arm is used, spread the pitman arm just enough, with a wedge, to slip the arm onto the pitman shaft. Do not spread the clamp more than required to slip over pitman shaft with hand pressure. Do not hammer the pitman arm onto the pitman shaft. Be sure to install the hardened steel washer before installing the nut.*

11. Install the horn button cap or shroud and connect the battery ground cable.
12. Lower the vehicle to the floor.

### Steering Gear High Point Centering

1. Set front wheels in straight ahead position. This can be checked by driving vehicle a short distance on a flat surface to determine steering wheel position at which vehicle follows a straight path.
2. With front wheels set straight ahead, check position of mark on wormshaft designating steering gear high point. This mark should be at the top side of the shaft at 12 o'clock position and lined up with the mark in the coupling lower clamp.

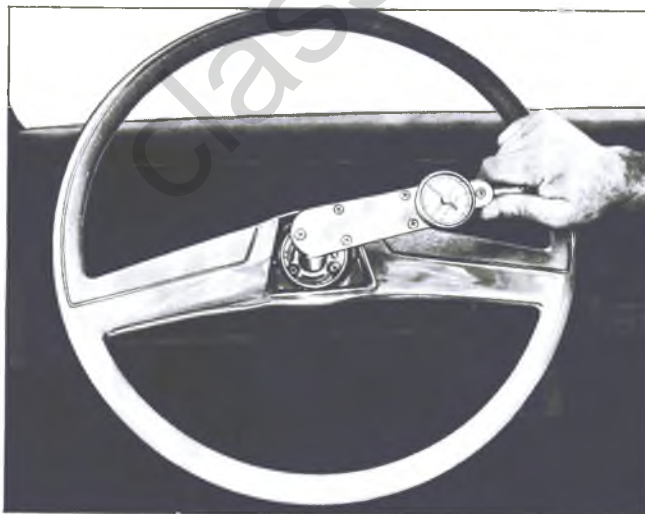

Fig. 34—Checking Torque at Steering Wheel

3. On C, G and P series if gear has been moved off high point when setting wheels in straight ahead position. Loosen adjusting sleeve clamps on both left and right hand tie rods, then turn both sleeves an equal number of turns in the same direction to bring gear back on high point.

**NOTE:** Turning the sleeves an unequal number of turns or in different directions will disturb the toe-in setting of the wheels.

4. On K series if the gear has been moved off high point when setting wheels in straight ahead position. Loosen adjusting sleeve clamps on the connecting rod then turn sleeve to bring gear back on high point.
5. Readjust toe-in as outlined in Section 3 (if necessary).
6. Be sure to properly orient sleeves and clamps as shown in figures 102 104 and 104B when fastening and torquing clamps to proper specifications.

### Steering Wheel Alignment

**NOTE:** On all series vehicles check steering gear for high point centering before checking steering wheel alignment.

1. Set wheels in straight ahead position by driving vehicle a short distance.
2. Note steering wheel position. If off more than 1 inch from center (fig. 35), remove steering wheel as outlined under "Steering Wheel - Removal", center high point on gear, reposition and reinstall the wheel.

### Steering Column Lower Bearing Adjustment G and P Series

1. Loosen clamp on steering shaft.
2. Applying 50 lb. force to the steering wheel end of

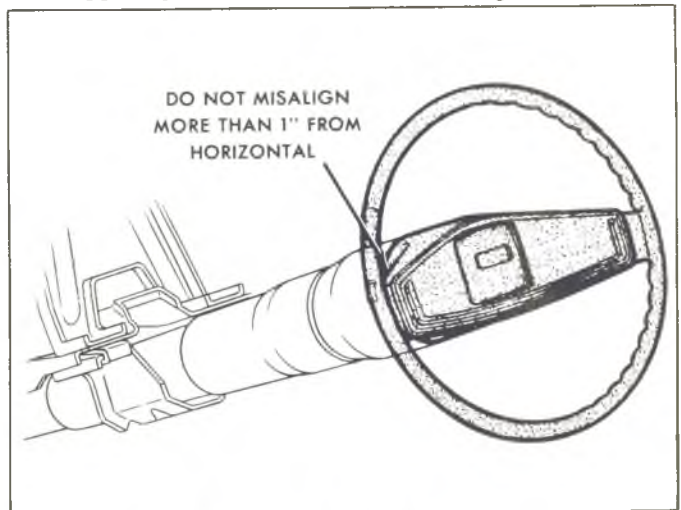

Fig. 35—Steering Wheel Alignment

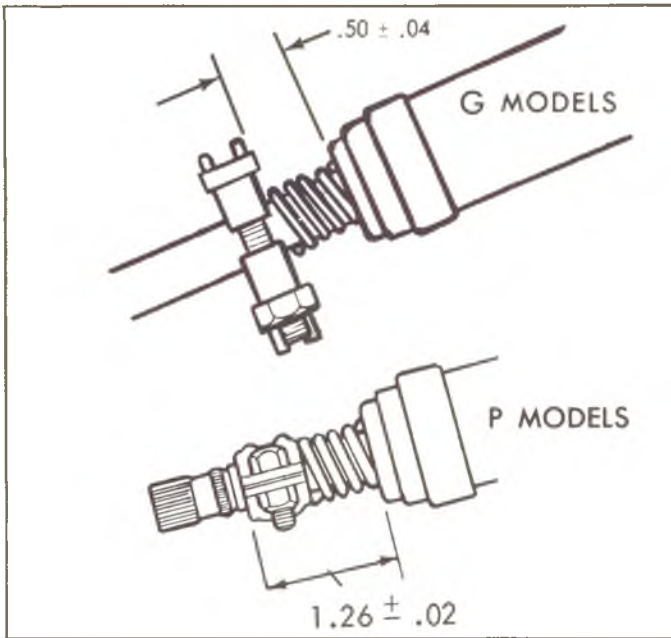

Fig. 36—Steering Column Lower Bearing Adjustment

the steering shaft, adjust clamp to obtain clearances indicated in Figure 36.

3. Tighten clamp bolt to specified torque.

### Shifter Tube Adjustment G and P Series

#### 3-Speed Transmission

1. Loosen adjusting ring attaching screws and clamp bolt.
2. Rotate adjusting ring to give .005" end play between adjusting ring and first and reverse shifter lever (fig. 37).
3. Tighten attaching screws and clamp bolt.



Fig. 37—Shift Tube Adjustment - 3 Speed Man. Transmission

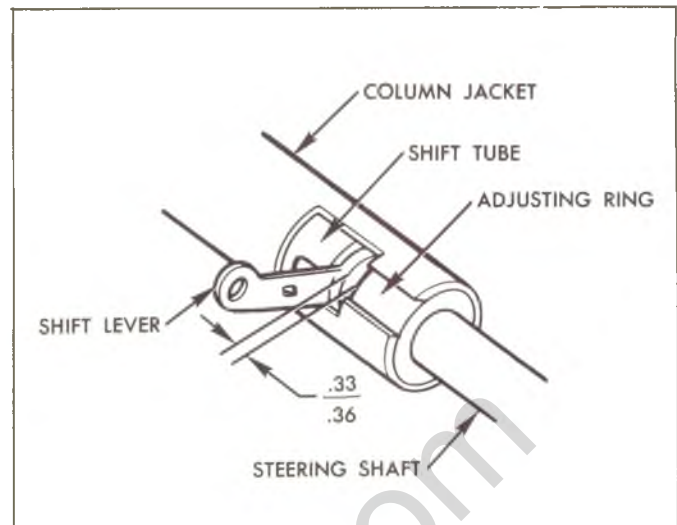

Fig. 38—Shift Tube Adjustment - Automatic Transmission

#### Automatic Transmission

1. Place the shift tube lever in "Neutral" or "Drive".
2. Loosen adjusting ring clamp screws and rotate the shift tube adjusting ring to obtain .33" to .36" clearance between the shift tube lever and adjusting ring (fig. 38).
3. Tighten the adjusting ring clamp screws to 70 in. lbs.

#### Power Steering Gear

The over-center adjustment (fig. 39) is the only power steering gear adjustment which can be made on the vehicle. However, in order to make this adjustment, it is also necessary to check the combined ball and thrust bearing preload.

**CAUTION:** See CAUTION on page 1 of this Section regarding the fastener referred to in step 10.

1. Disconnect the battery ground cable.
2. Raise and support front of vehicle so wheels hang free.
3. Remove the pitman shaft nut. Mark the relation of the pitman arm to the pitman shaft. Disconnect the pitman arm from the pitman shaft using Puller Tool J-6632 (fig. 48).
4. Loosen the pitman shaft adjusting screw locknut and thread the adjusting screw out to the limit of its travel through the side cover.
5. Remove the horn button cap or shroud.
6. Turn the steering wheel through its full travel, then locate the wheel at its center of travel.
7. Check the combined ball and thrust bearing preload with an inch-pound torque wrench on the steering shaft nut by rotating through the center of

travel (approximately 1/4 turn in each direction). Note the highest reading.

8. Tighten the pitman shaft adjusting screw and check torque at steering shaft nut until over-center preload and total steering gear preload falls within specifications. Refer to torque specifications at rear of manual for correct torque values.
9. Install horn button cap or shroud.
10. Connect the pitman arm to the pitman shaft, lining up the marks made at removal. Torque nut to specifications.
11. Lower vehicle to floor and connect the battery ground cable.

### Pump Belt Tension

1. Loosen pivot bolt and pump brace adjusting nuts.

**CAUTION:** Do not move pump by prying against reservoir or by pulling on filler neck.

2. Move pump, with belt in place until belt is tensioned to specifications as indicated by Tool J-23600 (Fig. 40).
3. Tighten pump brace adjusting nut. Then tighten pivot bolt nut.

### FLUID LEVEL

1. Check oil level in the reservoir by checking the dip stick when oil is at operating temperature. On models equipped with remote reservoir, the oil level should be maintained approximately 1/2 to 1 inch from top with wheels in full left turn position.
2. Fill, if necessary, to proper level with GM Power Steering Fluid or equivalent. If this is not available, any automatic transmission fluid bearing the mark Dexron®, or Dexron® II, or it's equivalent may be used.

NOTE: During flushing, overhaul or any operation where a complete change of fluid is

necessary use only power steering fluid or equivalent upon refilling.

### BLEEDING HYDRAULIC SYSTEM

1. Fill oil reservoir to proper level and let oil remain undisturbed for at least two minutes.
2. Start engine and run only for about two seconds.
3. Add oil if necessary.
4. Repeat above procedure until oil level remains constant after running engine.
5. Raise front end of vehicle so that wheels are off the ground.
6. Increase engine speed to approximately 1500 rpm.
7. Turn the wheels (off ground) right and left, lightly contacting the wheel stops.
8. Add oil if necessary.
9. Lower the vehicle and turn wheels right and left on the ground.
10. Check oil level and refill as required.
11. If oil is extremely foamy, allow vehicle to stand a few minutes with engine off and repeat above procedure.
  - a. Check belt tightness and check for a bent or loose pulley. (Pulley should not wobble with engine running.)
  - b. Check to make sure hoses are not touching any other parts of the truck, particularly sheet metal except where design calls for a clamp.
  - c. Check oil level, filling to proper level if necessary, following operations 1 through 10. This step and Step "D" are extremely important as low oil level and/or air in the oil are the most frequent causes of objectional pump noise.
  - d. Check the presence of air in the oil. If air is present, attempt to bleed system as described in operations 1 through 10. If it becomes obvious

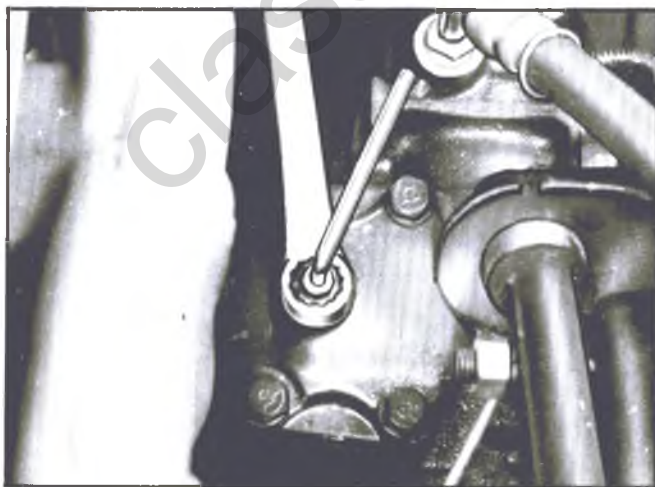

Fig. 39—Over-Center Adjustment



Fig. 40—Checking Belt Tension with J-23600

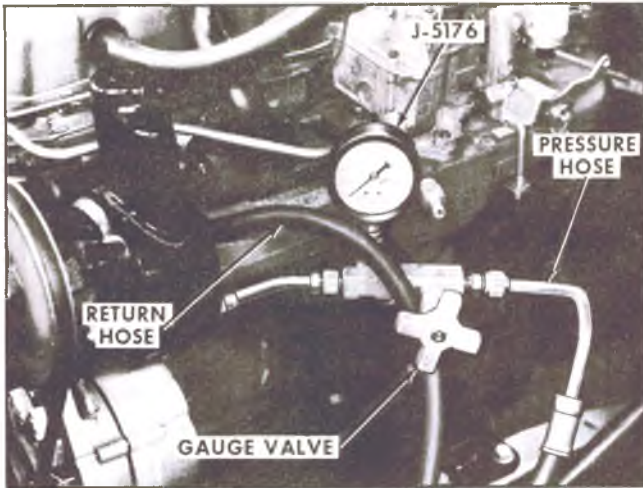

Fig. 41—Checking Power Steering Pressures

that the pump will not bleed after a few trials, proceed as outlined under Hydraulic System Checks.

## HYDRAULIC SYSTEM CHECKS

The following procedure outlines methods to identify and isolate power steering hydraulic circuit difficulties. The test provides means of determining whether power steering system hydraulic parts are actually faulty. This test will result in readings indicating faulty hydraulic operation, and will help to identify the faulty component.

Before performing hydraulic circuit test, carefully check belt tension, fluid level and condition of driving pulley.

### Power Steering Hydraulic System Test

Engine must be at normal operating temperature. Inflate front tires to correct pressure. All tests are made with engine idling, check idle adjustment and if necessary adjust engine idle speed to correct specifications listed in Section 6M and proceed as follows:

1. With engine NOT running disconnect pressure hose from pump and install Tool J-5176 using a spare pressure hose between gauge and pump. Gauge must be between shut-off valve and pump (Fig. 41). Open shut-off valve.
2. Remove filler cap from pump reservoir and check fluid level. Fill pump reservoir to full mark on dip stick. Start engine and, momentarily holding

steering wheel against stop, check connections at Tool J-5176 for leakage.

3. Bleed system as outlined under Maintenance and Adjustments.
4. Insert thermometer (Tool J-5421) in reservoir filler opening. Move steering wheel from stop to stop several times until thermometer indicates that hydraulic fluid in reservoir has reached temperature of 150° to 170°F.

**CAUTION:** To prevent scrubbing flat spots on tires, do not turn steering wheel more than five times without rolling vehicle to change tire-to-floor contact area.

5. Start engine and check fluid level adding any fluid if required. When engine is at normal operating temperature, the initial pressure read on the gage (valve open) should be in the 80-125 PSI range. Should this pressure be in excess of 200 PSI - check the hoses for restrictions and the poppet valve for proper assembly.
6. Close gate valve fully 3 times. Record the highest pressures attained each time. (Note: do not leave valve fully closed for more than 5 seconds as the pump could be damaged internally).
  - a. If the pressures recorded are within the listed specs and the range of readings are within 50 PSI, the pump is functioning within specs. (Ex. Spec. 1250 - 1350 PSI - readings - 1270 - 1275 - 1280).
  - b. If the pressures recorded are high, but do not repeat within 50 PSI, the flow controlling valve is sticking. Remove the valve, clean it and remove any burrs using crocus cloth or fine hone. If the system contains some dirt, flush it. If it is exceptionally dirty, both the pump and the gear must be completely disassembled, cleaned, flushed and reassembled before further usage.
  - c. If the pressures recorded are constant, but more than 100 PSI, below the low listed spec., replace the flow control valve and recheck. If the pressures are still low, replace the rotating group in the pump.
7. If the pump checks within specifications, leave the valve open and turn (or have turned) the steering wheel into both corners. Record the highest pressures and compare with the maximum pump pressure recorded. If this pressure cannot be built in either (or one) side of the gear, the gear is leaking internally and must be disassembled and repaired. See the current Overhaul Manual.
8. Shut off engine, remove testing gage, spare hose, reconnect pressure hose, check fluid level and/or make needed repairs.

## COMPONENT REPLACEMENT AND REPAIRS

### STEERING WHEEL

#### Removal G and P Series

1. Disconnect battery ground cable.
2. Remove horn button or shroud, receiving cup, Belleville spring and bushing and mark steering wheel to steering shaft relationship.
3. Remove steering shaft nut and washer.
4. Use Tool J-2927 to remove wheel (fig. 42).

#### Installation

**CAUTION:** See *CAUTION* on page 1 of this section regarding the fastener referred to in step 2.

**CAUTION:** Directional signal control assembly must be in neutral position when assembling steering wheel to prevent damage to cancelling cam and control assembly.

1. Place the steering wheel onto the steering shaft, aligning the marks made at removal.
2. Position into place and secure to proper torque with washer and nut.
3. Install Belleville spring, receiving cup, bushing and attaching screws.
4. Install horn button assembly.
5. Connect battery ground cable.

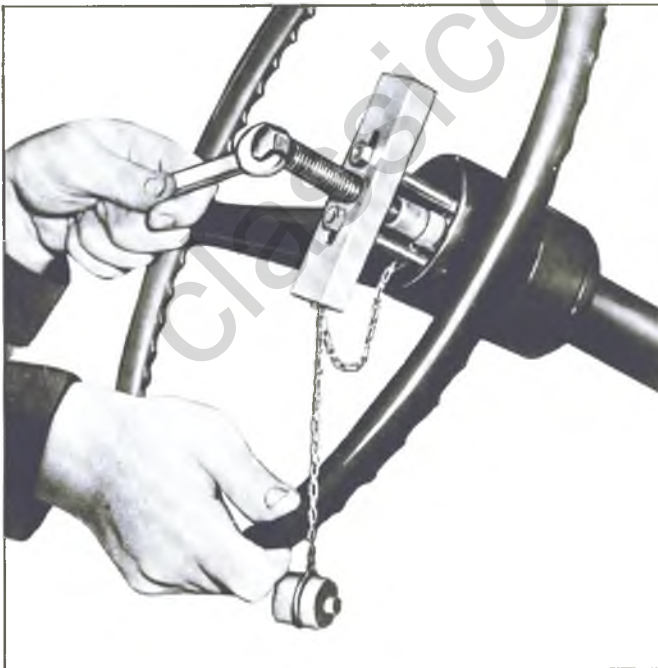

Fig. 42—Steering Wheel Removal Typical

#### Removal C and K Series

1. Disconnect battery ground cable.
2. Remove horn button cap.
3. Remove steering wheel nut.
4. Using tool J-2927, thread puller anchor screws into holes provided on steering wheel. Turn center bolt of tool clockwise to remove wheel.

**NOTE:** Do not hammer on puller. The tool centering adapters need not be used.

#### Installation

**CAUTION:** See *CAUTION* on page 1 of this section regarding the fasteners referred to in step 1.

1. With turn signal in neutral position, align marks and set wheel onto steering shaft. Torque steering shaft nut to specifications.

**CAUTION:** Do not over torque shaft nut or steering wheel rub may result.

2. Place steering wheel horn button on wheel and snap into proper position.
3. Connect battery ground cable.

### STEERING COUPLING

#### Flexible Type (Fig. 43)

##### Removal

1. Remove the coupling to steering shaft flange bolt nuts.
2. Remove the coupling clamp bolt.

**NOTE:** This is a special bolt and will require a 12 pt. socket or box wrench.

3. Remove the steering gear to frame bolts and lower the steering gear far enough to remove the flexible coupling.

**NOTE:** It is not necessary to disconnect the pitman arm from the pitman shaft.

4. Tap lightly on the flexible coupling with a soft mallet to remove the coupling from the steering gear wormshaft.

##### Installation

**CAUTION:** See *CAUTION* on page 1 of this section regarding the fasteners referred to in steps 2, 4 and 5.

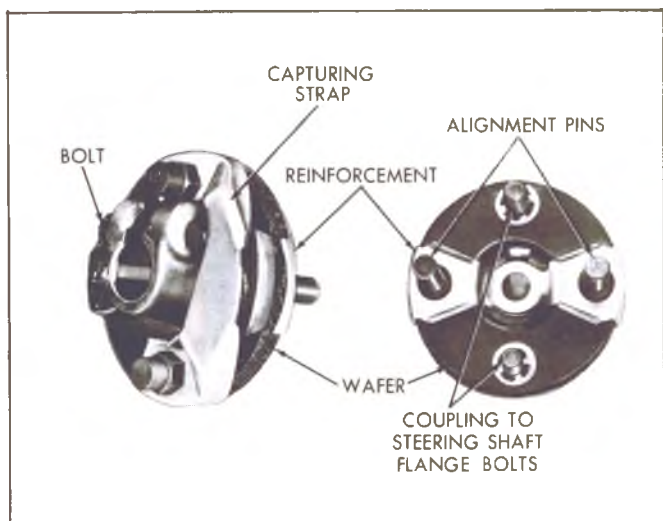

Fig. 43—Flexible Type Steering Coupling—Manual

1. Install the flexible coupling onto the steering gear wormshaft, aligning the flat on the shaft with the flat in the coupling.

**NOTE:** Push the coupling onto the wormshaft until the coupling reinforcement bottoms against the end of the worm.

2. Install the special bolt into the split clamp and torque to specifications.

**NOTE:** The bolt must pass through the shaft undercut.

3. Place the steering gear into position, guiding the flexible coupling bolts into the proper holes in the steering shaft flange.
4. Install and tighten the steering gear to frame bolts.
5. Install the coupling to flange bolt nuts and washers and torque to specifications. Be sure to maintain a coupling to flange dimension of .250" to .375". The coupling alignment pins should be centered in the flange slots.

## INTERMEDIATE STEERING SHAFTS WITH POT JOINT COUPLINGS

### Removal (Fig. 44)

1. Remove the lower shaft flange to flexible coupling bolts.
2. Remove upper shaft to intermediate coupling bolt.
3. If necessary, remove the steering gear to frame bolts and lower the steering gear far enough to remove the intermediate shaft assembly.

**NOTE:** It is not necessary to remove the pitman arm from the pitman shaft.

### Disassembly

1. Mark cover to shaft relationship. Pry off snap ring and slide cover from shaft.

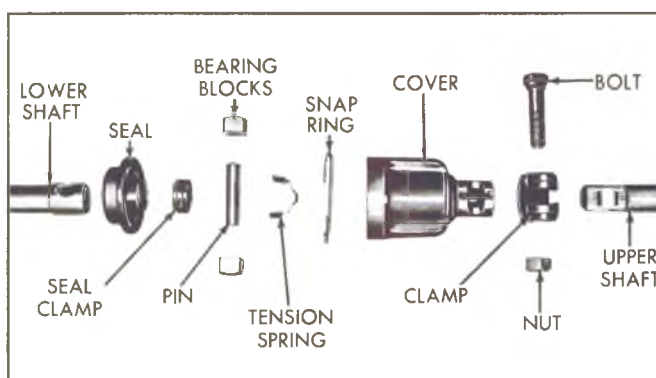

Fig. 44—Steering Shaft Intermediate Coupling (C and K)

2. Remove bearing blocks and tension spring from pivot pin.
3. Clean grease off pin and end of shaft. Scribe location mark on pin on same side as chamfer in shaft.
4. Supporting shaft assembly securely, with chamfer up, press pin out of shaft with arbor press.

**CAUTION:** Do not drive pin out with hammer. This will cause sticky or binding bearings when reassembled.

5. Remove seal clamp and slide seal off end of shaft.

### Assembly

1. Be sure all parts are free of dirt. Slide seal onto steering shaft. With lip of seal against step in shaft clamp seal.
2. Press pin back into shaft from chamfered side. Locate pin in shaft using scribe mark as reference.
 

**CAUTION:** Pin must be centered within .012 in. or binding in the coupling will result.
3. Check centering of pin (fig. 45).
  - a. Place just enough 3/8" flat washers on pin to prevent bearing block from bottoming when installed.
  - b. Measure distance from end of pin to top of bearing with micrometer.
  - c. Remove bearing and washers and place same bearing and washers on other end of pin. Measure distance from end of pin to top of bearing. If micrometer readings in Steps b and c differ more than .012, repeat last part of Step 2 and recheck.
4. Apply a liberal amount of wheel bearing grease to inside and outside of bearing blocks and inside of cover.
5. Position tension spring and bearing blocks on pin.
6. Slide cover over bearing blocks aligning reference mark on cover with mark on shaft. Install seal into end of cover and secure with snap ring retainer.



**Installation**

**CAUTION:** See *CAUTION* on page 1 of this section regarding the fasteners referred to in steps 1, 3 and 4.

1. Install the intermediate shaft assembly onto the steering shaft, aligning the flat on the shaft with the flat in the coupling. Install the pot joint clamp bolt and torque to specifications.
2. Lift the steering gear into position, guiding the flexible coupling bolts into the shaft flange holes.
3. Install the steering gear to frame bolts and torque to specifications.
4. Install the flexible coupling to steering shaft flange bolt lockwashers and nuts. Check that the coupling alignment pins are centered in the flange slots and then torque the coupling bolts to specifications.

### INTERMEDIATE STEERING SHAFT WITH UNIVERSAL JOINT COUPLINGS

#### Removal (Fig. 46)

1. Set front wheels in straight ahead position. This can be done by driving the vehicle a short distance on a flat surface.
2. Mark upper universal joint yoke to steering shaft relationship and lower yoke to steering gear wormshaft relationship.
3. Remove both upper and lower universal yoke pinch bolts.
4. Remove steering gear to frame bolts and lower the gear.

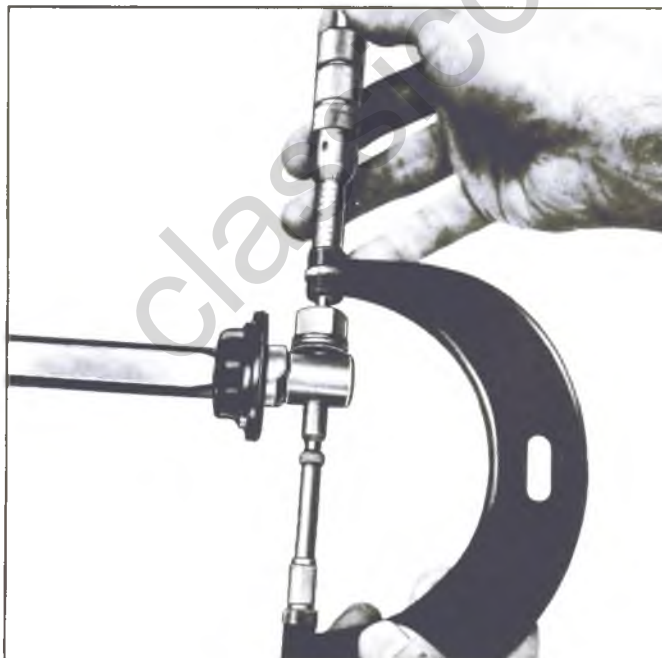

Fig. 45—Checking Coupling Pin Centering

**NOTE:** It is not necessary to disconnect the pitman arm from the steering gear pitman shaft.

5. Remove the intermediate steering shaft and universal joint assembly.

#### Disassembly

1. If the upper or lower half of the intermediate steering shaft is to be replaced, proceed as follows:
  - a. With the shaft assembly on a bench, straighten the tangs on the dust cap. Separate the upper and lower portions of the shaft assembly.
  - b. Remove the felt washer, plastic washer and dust cap. Discard the felt washer.
2. If the trunnion assemblies are to be replaced, proceed as follows:
  - a. Remove the snap rings retaining the trunnion bushings in one of the yokes.
  - b. Support the yoke on a bench vise and drive out one bushing by tapping on the opposite bushing using a soft drift and hammer.
  - c. Support the other side of the yoke and drive out the remaining bushing as in Step b above.
  - d. Move the yoke on the trunnion as necessary to separate the upper and lower yokes.
  - e. Remove the trunnion from the lower yoke as outlined in Steps a through d above. Remove and discard the seals.

#### Assembly

1. If the yoke trunnions were removed, reassemble as follows:
  - a. Place the new trunnion into the lower yoke.
  - b. Place new seals onto the trunnion and then press the new bushings into the yoke and over

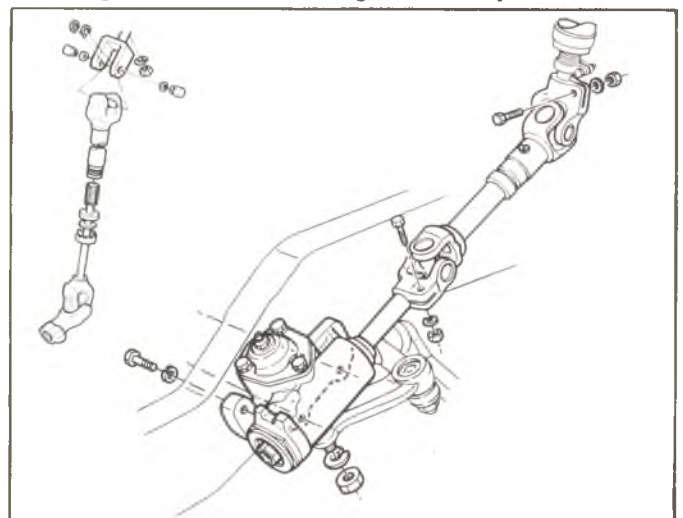

Fig. 46—Intermediate Steering Shaft — P Series

## 9-32 STEERING

the trunnion hubs far enough to install the snap rings.

- c. Install the snap rings.
  - d. Repeat Steps a through c to attach the upper yoke to the trunnion.
2. Reassemble the intermediate shaft assembly as follows:
    - a. Place the dust cap, plastic washer and a new felt seal over the shaft on the lower yoke assembly.
    - b. Align the arrow on the lower yoke assembly shaft with the arrow on the upper yoke assembly tube and push the two assemblies together.
    - c. Push the dust cap, plastic washer and felt washer into position on the lower end of the upper yoke assembly and bend the tangs of the dust cap down against the yoke tube.

### Installation

**CAUTION:** See *CAUTION* on page 1 of this section regarding the fasteners referred to in steps 1, 3 and 4.

1. Align the marks made at removal and assemble the intermediate shaft lower yoke onto the steering gear wormshaft. Install the pinch bolt and torque to specifications.

**NOTE:** The pinch bolt must pass through the shaft undercut. If a new yoke was installed, the slit in the yoke should be up (12 o'clock position).

2. Raise the steering gear into position while guiding the upper yoke assembly onto the steering shaft.

**NOTE:** The marks on the coupling and steering shaft must align. If a new yoke was installed, assemble the upper yoke to the steering shaft with the steering wheel in straight ahead position (gear must be on high point).

3. Install the steering gear to frame bolts and torque to specifications.
4. Install the upper yoke to steering shaft pinch bolt and torque to specifications.

**NOTE:** The pinch bolt must pass through the shaft undercut.

## STEERING GEAR

### Removal

1. Set the front wheels in straight ahead position by driving vehicle a short distance on a flat surface.
2. Remove the flexible coupling to steering shaft flange bolts (C-K models) or the lower universal joint pinch bolt (P models). Mark the relationship of the universal yoke to the wormshaft.
3. Mark the relationship of the pitman arm to the

pitman shaft. Remove the pitman shaft nut or pitman arm pinch bolt and then remove the pitman arm from the pitman shaft using Puller J-6632 (fig. 48).

4. Remove the steering gear to frame bolts and remove the gear assembly.
5. **C-K Models** — Remove the flexible coupling pinch bolt and remove the coupling from the steering gear wormshaft.

### Installation

**CAUTION:** See *CAUTION* on page 1 of this section regarding the fasteners referred to in steps 1a, 1c, 1d, 1e, 2b, 2c, and 3.

1. **C-K Models**
  - a. Install the flexible coupling onto the steering gear wormshaft, aligning the flat in the coupling with the flat on the shaft. Push the coupling onto the shaft until the wormshaft bottoms on the coupling reinforcement. Install the pinch bolt and torque to specifications.

**NOTE:** The coupling bolt must pass through the shaft undercut.

- b. Place the steering gear in position, guiding the coupling bolt into the steering shaft flange.
- c. Install the steering gear to frame bolts and torque to specifications.
- d. If flexible coupling alignment pin plastic spacers were used, make sure they are bottomed on the pins, torque the flange bolt nuts to specifications and then remove the plastic spacers.
- e. If flexible coupling alignment pin plastic spacers were not used, center the pins in the slots in the steering shaft flange and then install and torque the flange bolt nuts to specifications.

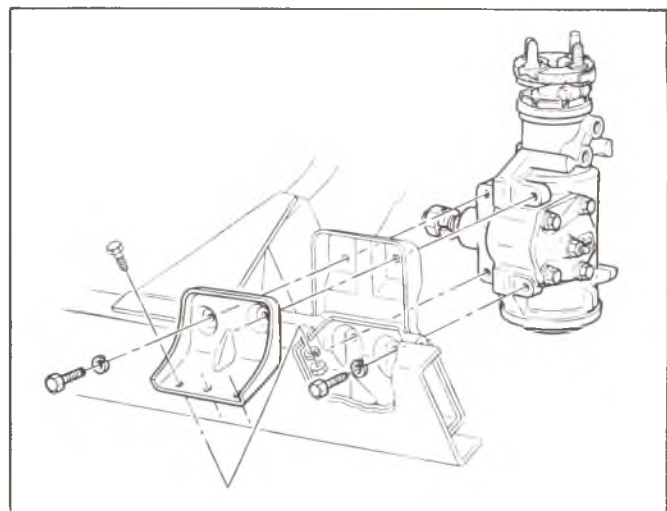

Fig. 47—Steering Gear Mounting—Motor Home - Typical

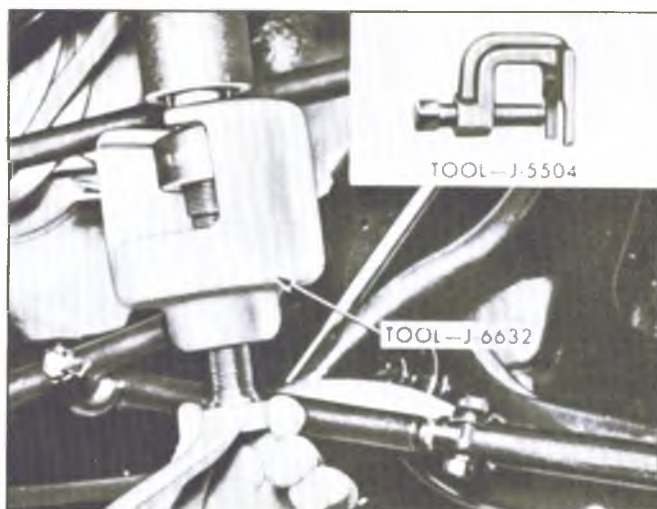

Fig. 48—Removing Pitman Arm — Typical

## 2. P Models

- a. Place the steering gear in position, guiding the wormshaft into the universal joint assembly and lining up the marks made at removal.

**NOTE:** If a new gear was installed, line up the mark on the wormshaft with the slit in the universal joint yoke.

- b. Install the steering gear to frame bolts and torque to specifications.
- c. Install the universal joint pinch bolt and torque to specification.

**NOTE:** The pinch bolt must pass through the shaft undercut.

3. Install the pitman arm onto the pitman shaft, lining up the marks made at removal. Install the pitman shaft nut or pitman arm pinch bolt and torque to specifications.

**CAUTION:** If a clamp type pitman arm is used, spread the pitman arm just enough, with a wedge, to slip the arm onto the pitman shaft. Do not spread the clamp more than required to slip over pitman shaft with hand pressure. Do not hammer the pitman arm onto the pitman shaft. Be sure to install the hardened steel washer before installing the nut.

## PITMAN SHAFT SEAL REPLACEMENT

### Manual Steering Gear

A faulty seal may be replaced without removal of steering gear from C, G and P trucks by removing pitman arm as outlined under Maintenance and Adjustments - Steering Gear Adjustments and proceed as follows:

**NOTE:** On K series vehicles remove the gear from the vehicle first.

1. Rotate the steering wheel from stop to stop, counting the total number of turns. The turn back exactly half-way, placing the gear on center (the wormshaft flat should be at the 12 o'clock position).
2. Remove the three self-locking bolts attaching side cover to the housing and lift the pitman shaft and side cover assembly from the housing.
3. Pry the pitman shaft seal from the gear housing using a screwdriver and being careful not to damage the housing bore.

**CAUTION:** Inspect the lubricant in the gear for contamination. If the lubricant is contaminated in any way, the gear must be removed from the vehicle and completely overhauled as outlined in the Overhaul Manual.

4. Coat the new pitman shaft seal with Steering Gear Lubricant meeting GM Specification GM4673M (or equivalent). Position the seal in the pitman shaft bore and tap into position using a suitable size socket.
  5. Remove the lash adjuster lock nut. Remove the side cover from the pitman shaft assembly by turning the lash adjuster screw clockwise.
  6. Place the pitman shaft in the steering gear such that the center tooth of the pitman shaft sector enters the center tooth space of the ball nut.
  7. Fill the steering gear housing with Steering Gear Lubricant meeting GM Specification GM4673M (or equivalent).
  8. Install a new side cover gasket onto the gear housing.
  9. Install the side cover onto the lash adjuster screw by reaching through the threaded hole in the side cover with a small screwdriver and turning the lash adjuster screw counter-clockwise until it bottoms and turn back in 1/4 turn.
  10. Install the side cover bolts and torque to specifications.
  11. Install the lash adjuster screw locknut, perform steering gear adjustment and install the pitman arm as outlined under "Maintenance and Adjustments".
- NOTE:** On K series install the gear into the vehicle using previously outlined procedure.

## DIRECTIONAL SIGNAL SWITCH

The directional signal switch can be removed with the steering column in the vehicle and without disturbing any of the column mountings.

### C and K Series

#### Removal

1. Remove the steering wheel as outlined under "Steering Wheel - Removal".
2. Remove the column to instrument panel trim cover.

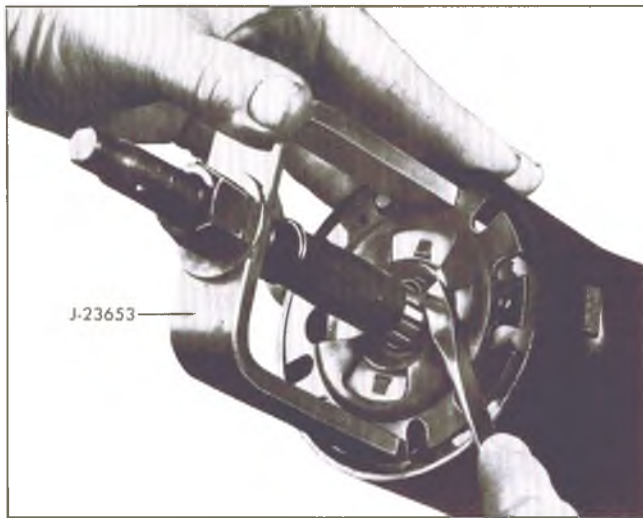

Fig. 49—Removing Lock Plate Retaining Ring

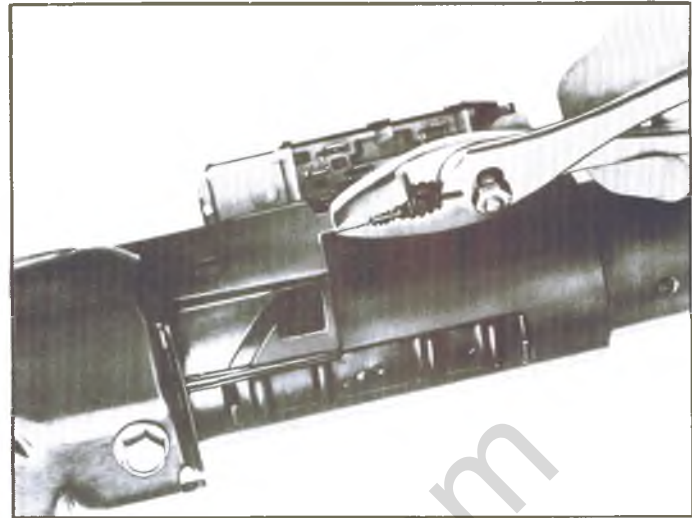

Fig. 50—Removing Directional Signal Wire Protector

3. Remove the three cover screws and lift the cover off the shaft.

**NOTE:** The cover screws have plastic retainers on the back of the cover so it is not necessary to completely remove these screws.

4. Screw the center post of Lock Plate Compressing Tool J-23653 onto the steering shaft as far as it will go. Compress the lock plate by turning the center post nut clockwise (fig. 49). Pry the round wire snap ring out of the shaft groove and discard the ring. Remove Tool J-23653 and lift the lock plate off the end of the shaft.

**CAUTION:** If the column is being disassembled on the bench, with the snap ring removed the shaft could slide out of the lower end of the mast jacket, damaging the shaft assembly.

5. Slide the directional signal cancelling cam, upper bearing preload spring and thrust washer off the end of the shaft.
6. Remove the directional signal lever screw and remove the lever.
7. Push the hazard warning knob in and unscrew the knob.
8. Remove the three switch mounting screws.
9. **All Columns** - Pull the switch connector out of the bracket on the jacket and feed switch connector through column support bracket and pull switch straight up, guiding the wiring harness through the column housing and protector.

10. Remove wire protector by pulling downward out of column with pliers using tab provided (fig. 50).

**Tilt Column** - Position the directional signal and shifter housing in the "low" position. Remove the harness cover by pulling toward the lower end of the column, be careful not to damage the wires.

11. Remove the three switch mounting screws and pull the switch straight up, guiding the wiring harness and cover through the column housing (fig. 51).

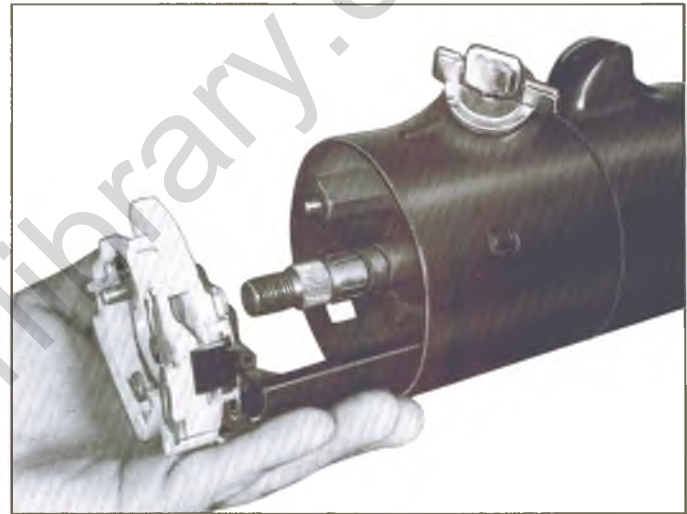

Fig. 51—Removing Directional Signal Switch Assembly

### Installation

**CAUTION:** It is extremely important that only the specified screws, bolts and nuts be used at assembly. Use of overlength screws could prevent a portion of the assembly from compressing under impact.

1. **All except Tilt** - Be sure that the wiring harness is in the protector. Feed the connector and cover down through the housing and under the mounting bracket (column in vehicle.)

**Tilt** - Feed the connector down through the housing and under the mounting bracket. Then install the cover on the harness.

2. Install the three mounting screws and clip the connector to the bracket on the jacket (fig. 52).
3. Install the column to instrument panel trim plate.

4. Install the hazard warning knob and directional signal lever.
5. Make certain that the switch is in "Neutral" and the hazard warning knob is out. Slide the thrust washer, upper bearing preload spring and canceling cam onto the upper end of the shaft.
6. Place the lock plate onto the end of the shaft. Screw the center post of Lock Plate Compressing Tool J-23653 onto the steering shaft as far as it will go. Place a NEW snap ring over the center post. Place the "C" bar over the center post and then compress the lock plate by turning the nut clockwise. Slide the new snap ring down the tapered center post and into the shaft groove (fig. 53). Remove Tool J-23653.

**CAUTION:** Always use a new snap ring when reassembling.

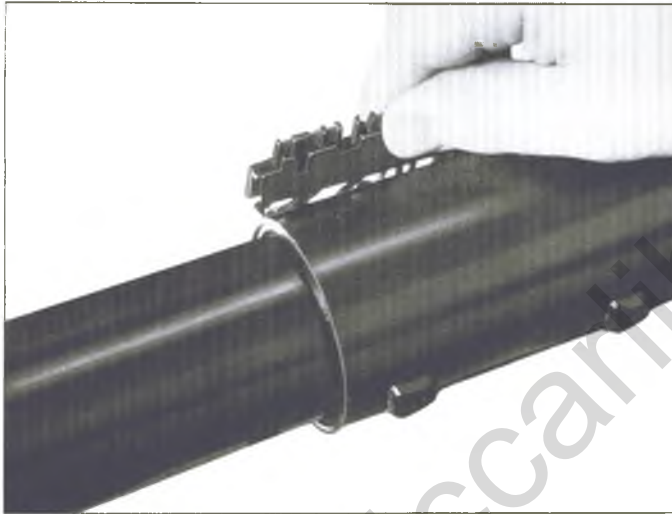

Fig. 52—Installing Switch Connector Onto Jacket Clips



Fig. 53—Installing Snap Ring

7. Place the cover on the end of the shaft and reinstall the three screws.
8. Install the steering wheel as outlined under "Steering Wheel - Installation".

### LOCK CYLINDER (C AND K SERIES)

The lock cylinder is located on the upper right hand side of the column. The lock cylinder should be removed in the "RUN" position only.

#### Removal

1. Remove the steering wheel as outlined under "Steering Wheel - Removal".
2. Remove the directional signal switch as outlined under "Directional Signal Switch - Removal".

**NOTE:** It is not necessary to completely remove the directional signal switch from the column. Pull the switch rearward far enough to slip it over the end of the shaft - do not pull the harness out of the column.

3. Insert a small screw driver or similar tool into the turn signal housing slot as shown in Figure 54. Keeping the tool to the right side of the slot, break the housing flash loose and at the same time depress the spring latch at the lower end of the lock cylinder. With the latch depressed, the lock cylinder can be removed from the housing.

#### Assembly (Fig. 55)

1. Place the key part way into the lock cylinder assembly. Place the wave washer and anti-theft ring onto the lower end of the lock cylinder.

**NOTE:** If the key is installed all the way into

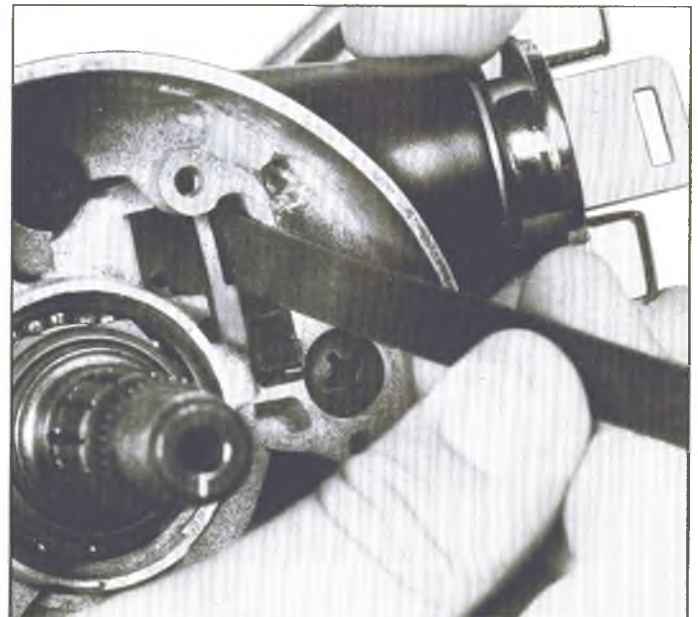

Fig. 54—Lock Cylinder Removal

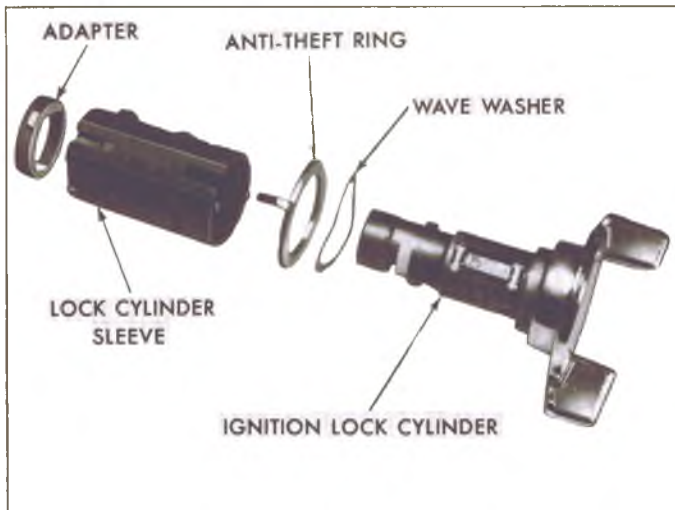

Fig. 55—Ignition Lock Cylinder Explode

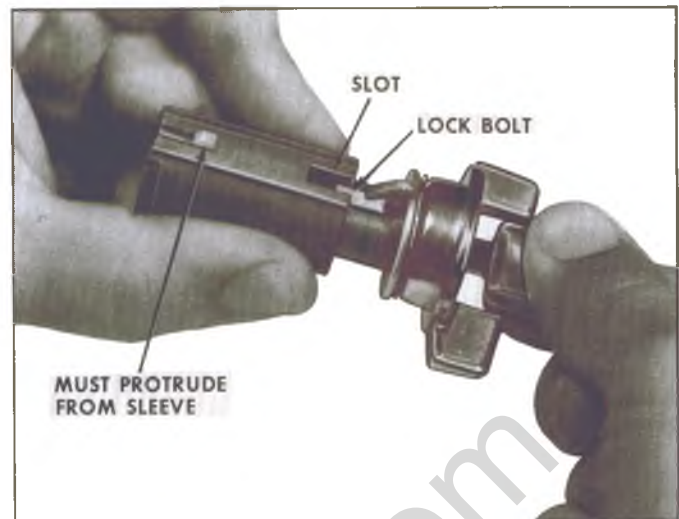

Fig. 56—Ignition Lock Cylinder Assembly

the lock cylinder, the plastic keeper in the lock cylinder protrudes and prevents installation of the sleeve assembly.

2. Make sure that the plastic keeper in the sleeve assembly protrudes from the sleeve (fig. 56).
3. Align the lock bolt on the lock cylinder and the tab on the anti-theft washer and the slot in the sleeve assembly (fig. 56). Push the sleeve all the way onto the lock cylinder assembly, push the ignition key the rest of the way in and rotate the lock cylinder clockwise.
4. Rotate the lock counter-clockwise into "LOCK" position.
5. Place the lock in a brass jawed vise or between two pieces of wood (fig. 57).

NOTE: If a vise is used, place cloth around the knob to prevent marring the knob surface.

6. Place the adapter ring onto the lower end of the cylinder so that the finger of the adapter is located at the step in the sleeve and the serrated edge of the adapter is visible after assembly to the cylinder and before "staking" (fig. 58). The key must be free to rotate at least 1/3 of a circle (120°).

NOTE: Tap the adapter onto the cylinder until it is stopped at the bottom of the cylinder flats (cylinder will extend above adapter approximately 1/16").

7. Using a small flat punch, at least 1/8" in diameter, stake the lock cylinder over the adapter ring in four places just outboard of the four dimples as shown in Figure 58.
8. Check lock operation before reinstalling vehicle.



Fig. 57—Ignition Lock Cylinder Installed in a Vise

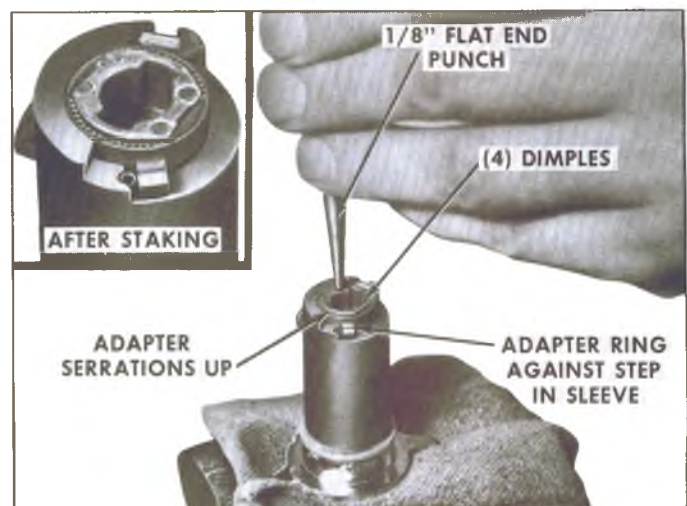

Fig. 58—Installing Adapter Ring

**Installation**

1. Hold the lock cylinder sleeve and rotate the knob clockwise against the stop. Insert the cylinder into

the housing bore with the key on the cylinder sleeve aligned with the keyway in the housing. Push the

cylinder into abutment of cylinder and sector. Hold an .070" drill between the lock bezel and housing. Rotate the cylinder counterclockwise, maintaining a light pressure until the drive section of the cylinder mates with the sector. Push in until the snap ring pops into the grooves and the lock cylinder is secured in the housing. Remove the .070" drill. Check lock cylinder for freedom of rotation.

2. Install the Direction Signal Switch and Steering Wheel as outlined previously in this section.

### IGNITION SWITCH (C AND K SERIES)

The ignition switch is mounted on top of the column jacket near the front of the dash. For anti-theft reasons, the switch is located inside the channel section of the brake pedal support and is completely inaccessible without first lowering the steering column (see steering column removal).

The switch is actuated by a rod and rack assembly. A portion of the rack is toothed and engages a gear on the

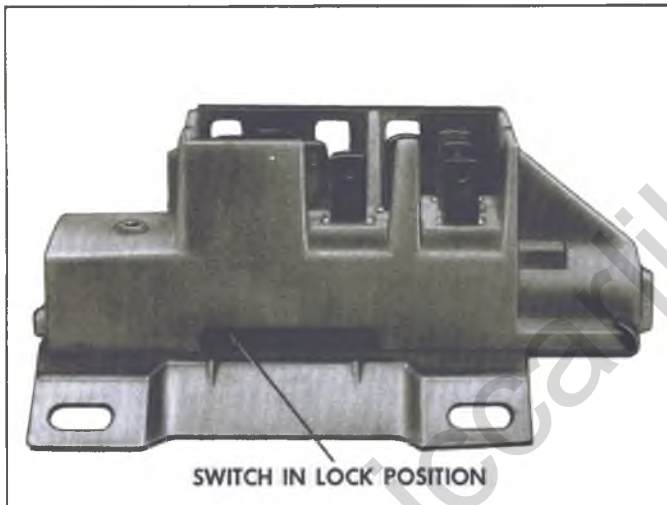

Fig. 59—Ignition Switch Assembly

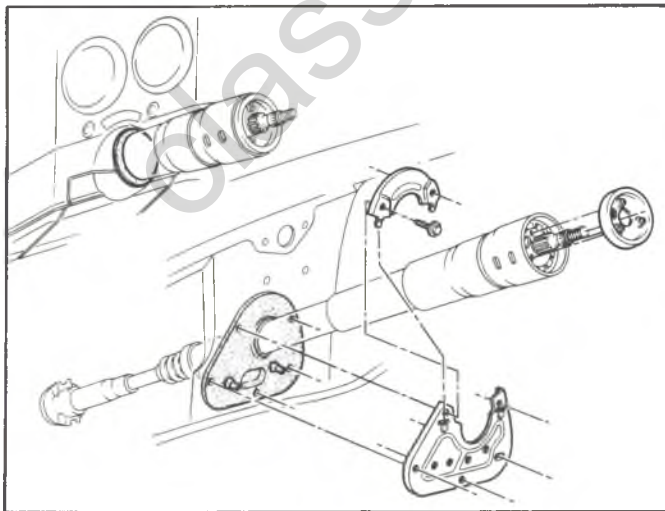

Fig. 60—Steering Column Cover and Seal

end of the lock cylinder, thus enabling the rod and rack to be moved axially (with respect to the column) to actuate the switch when the lock cylinder is rotated.

### Removal

1. Lower the steering column as outlined under "Steering Column Removal" later in this section. It is not necessary to remove the steering wheel.

**CAUTION:** *If the steering column is not removed from the vehicle, be sure that it is properly supported, before proceeding.*

2. The switch should be positioned in "Lock" position before removing. If the lock cylinder has already been removed, the actuating rod to the switch should be pulled up until there is a definite stop, then moved down one detent, which is the "Lock" position.
3. Remove the two switch screws and remove the switch assembly.

### Installation

1. Before replacing the switch, be sure that the lock is in the "Lock" position. Make certain that the switch is in "Lock" position (fig. 59); if it is not, a screwdriver (placed in the locking rod slot) can be used to move the switch to "Lock".
  2. Install the activating rod into the switch and assemble the switch on the column; tighten the mounting screws.
- CAUTION:** *Use only the specified screws since over-length screws could prevent a portion of the assembly from compressing under impact.*
3. Reinstall the steering column assembly following the "Mandatory Installation Sequence" outlined later in this section.

### STEERING COLUMN

All models which are equipped with the Function Locking Energy Absorbing Steering Columns are one of five basic designs.

1. **Synchromesh** — The synchromesh column is used on models with the standard transmission and column mounted shift levers. The shift tube, within the outer column jacket, includes two lower shift levers for connection to the transmission control linkage. This column does not lock the transmission when the lock cylinder is in the "lock" position.
2. **Floor Shift** — This column is used on models equipped with a manual transmission with the shift lever on the floor. This column does not lock the transmission when the lock cylinder is in the "lock" position.
3. **Automatic Column Shift**—this column is used on all models with an automatic transmission and a standard column. This column has a single lower shift lever for shifting the automatic transmission.

## 9-38 STEERING

The transmission is locked in Park when the lock cylinder is in "Lock", thus locking the transmission.

4. **Tilt Column Option automatic transmission** – The upper end and steering shaft of this column is specifically designed to accommodate the optional tilt steering wheel. The lower portion of the column is the same as in item number 3.
5. **Tilt Column Option Manual Transmission**—This column is the same as the automatic transmission tilt column except incorporating provisions for the manual transmission shifting and the transmission is not locked when the lock cylinder is in "Lock" position.

To perform service procedures on the steering column upper end components, it is not necessary to remove the column from the vehicle.

The steering wheel, horn components, directional signal switch, and ignition lock cylinder may be removed with the column remaining in the vehicle as described earlier in this section.

**CAUTION:** *The outer mast jacket shift tube, steering shaft and instrument panel mounting bracket are designed as energy absorbing units. Because of the design of these components, it is absolutely necessary to handle the column with care when performing any service operation. Avoid hammering, jarring, dropping or leaning on any portion of the column. When reassembling the column components, use only the specified screws, nuts and bolts and tighten to specified torque. Care should be exercised in using over-length screws or bolts as they may prevent a portion of the column from compressing under impact.*

### Inspection

To determine if the energy absorbing steering column components are functioning as designed, or if repairs are required, a close inspection should be made. Inspection is called for in all cases where damage is evident or whenever the vehicle is being repaired due to a front end collision. Whenever a force has been exerted on the steering wheel or steering column, or its components, inspection should also be made. If damage is evident, the affected parts must be replaced.

The inspection procedure for the various steering column components on all C and K Series Trucks is as follows:

#### Column Support Bracket

Damage in this area will be indicated by separation of the mounting capsules from the bracket. The bracket will have moved forward toward the engine compartment and will usually result in collapsing of the jacket section of the steering column.

#### Column Jacket

Inspect jacket section of column for looseness, and/or bends.

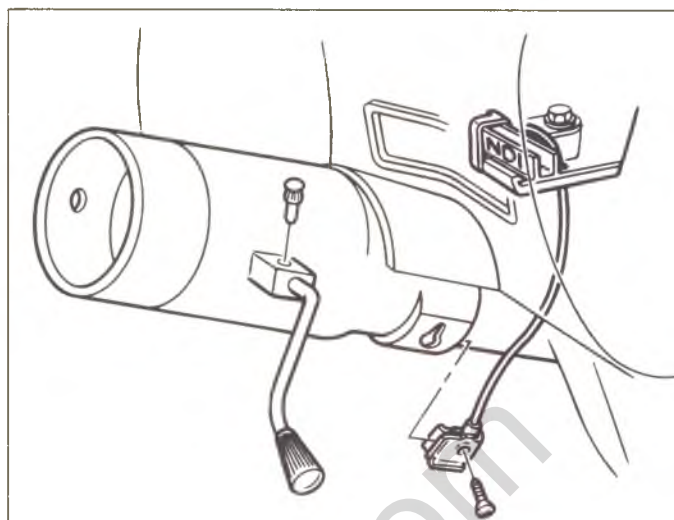

Fig. 61—Automatic Transmission Indicator Connection CK (Typical)

#### Shifter Shaft

Separation of the shifter shaft sections will be internal and cannot be visually identified. Hold lower end of the "shifter shaft" and move "shift lever" on column through its ranges and up and down. If there is little or no movement of the "shifter shaft", the plastic joints are sheared.

#### Steering Shaft

If the steering shaft plastic pins have been sheared, the shaft will rattle when struck lightly from the side and some lash may be felt when rotating the steering wheel while holding the rag joint. It should be noted that if the steering shaft pins are sheared due to minor collision with no appreciable damage to other components, that the vehicle can be safely steered; however, steering shaft replacement is recommended.

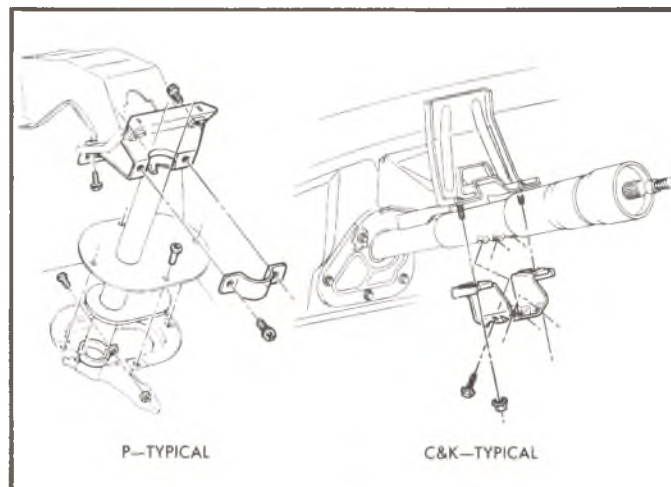

Fig. 62—Steering Column to Dash Panel - C, P and K Typical



Because of the differences in the steering column types, be sure to refer to the set of instructions below which apply to the column being serviced.

### COLUMN REMOVAL—C AND K COLUMNS

NOTE: Front of dash mounting plates must be loosened whenever the steering column is to be lowered from the instrument panel.

1. Disconnect the battery ground cable.
2. Remove the steering wheel as outlined under "Steering Wheel Removal".
3. Remove the nuts and washers securing the flanged end of the steering shaft to the flexible coupling.
4. Disconnect the transmission control linkage from the column shift tube levers.
5. Disconnect the steering column harness at the connector. Disconnect the neutral-start switch and back-up lamp switch connectors if so equipped.
6. Remove the floor pan trim cover screws and remove the cover.
7. Remove the screws securing the two halves of the floor pan cover; then remove the screws securing the halves and seal to the floor pan and remove the covers (figs. 62 and 63).
8. Remove the transmission indicator cable, if so equipped (fig. 61).
9. Move the front seat as far back as possible to provide maximum clearance.
10. Remove the two column bracket-to-instrument panel nuts and carefully remove from vehicle. Additional help should be obtained to guide the lower shift levers through the firewall opening.

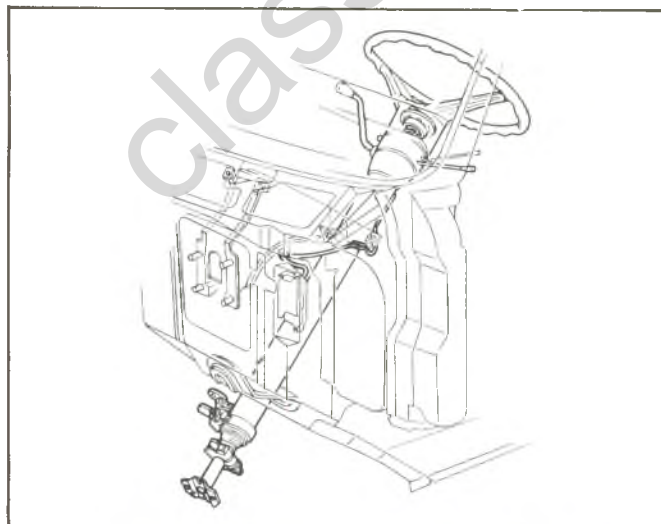

Fig. 63—Steering Columns to Dash Panel - G

### DISASSEMBLY—C AND K SERIES EXCEPT TILT COLUMNS—(Fig. 64)

NOTE: G and P Series columns differ from those shown in Figures 64 thru 72.

1. Remove the four dash panel bracket-to-column screws and lay the bracket in a safe place to prevent damage to the mounting capsules.
2. Place the column in a vise using both weld nuts of either Set A or B as shown in Figure 65. The vise jaws must clamp onto the sides of the weld nuts indicated by arrows shown on Set B.
 

**CAUTION:** Do not place the column in a vise by clamping onto only one weld nut, by clamping onto one weld nut of both sets A and B or by clamping onto the sides not indicated by arrows, since damage to the column could result.
3. Remove the Directional Signal Switch, Lock Cylinder, and Ignition Switch as outlined previously in this section.
4. **Column Shift Models** —Drive out the upper shift lever pivot pin and remove the shift lever.
5. Remove the upper bearing thrust washer. Remove the four screws attaching the turn signal and ignition lock housing to the jacket and remove the housing assembly (fig. 66).
6. Remove the thrust cap from the lower side of the housing.
7. Lift the ignition switch actuating rod and rack assembly, the rack preload spring and the shaft lock bolt and spring assembly out of the housing (fig. 67).
8. Remove the shift lever detent plate (shift gate).
9. Remove the ignition switch actuator sector through the lock cylinder hole by pushing firmly on the block tooth of the sector with a blunt punch or screwdriver (fig. 68).
10. Remove the gearshift lever housing and shroud from the jacket assembly (transmission control lock tube housing and shroud on floor shift models).
11. Remove the shift lever spring from the gearshift lever housing (lock tube spring on floor shift models).
12. Pull the steering shaft from lower end of the jacket assembly.
13. Remove the two screws holding the back-up switch or neutral-safety switch to the column and remove the switch.
14. Remove the lower bearing retainer clip (fig. 69).
15. **Automatic and Floorshift Columns** — Remove the lower bearing retainer, bearing adapter assembly, shift tube thrust spring and washer. The lower bearing may be removed from the adapter by light

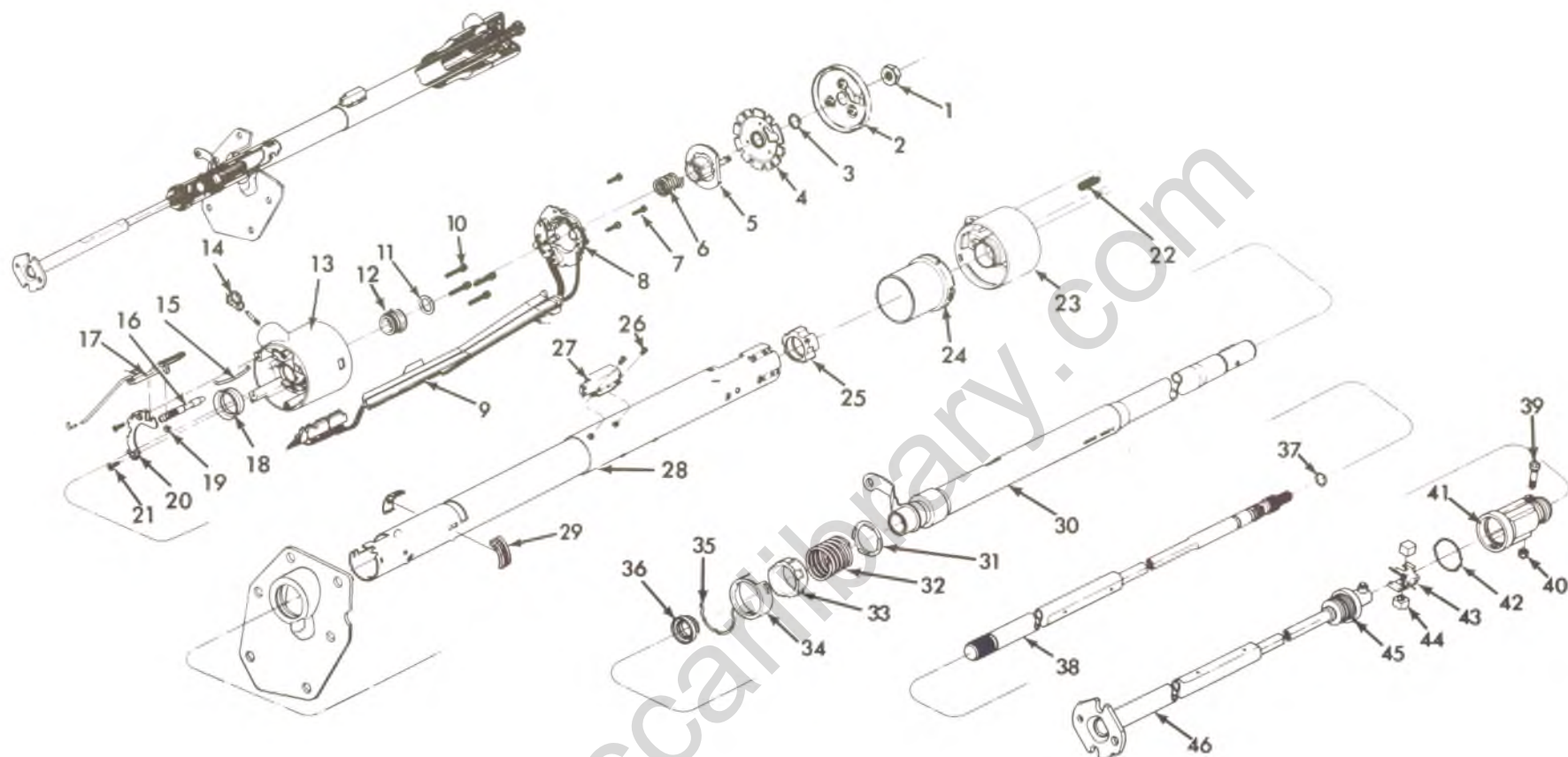

- |                                |                                  |  |                         |
|--------------------------------|----------------------------------|--|-------------------------|
| 1. Shaft Nut                   | 12. Upper Bearing                | 24. Shift Shroud                               | 35. Retainer            |
| 2. Cover                       | 13. Turn Signal Housing          | 25. Gearshift Housing Bearing                  | 36. Lower Bearing       |
| 3. Lock Plate Retaining Ring   | 14. Ignition Switch Sector       | 26. Ignition Switch Screws                     | 37. Shaft Stop Ring     |
| 4. Lock Plate                  | 15. Switch Rack Preload Spring   | 27. Ignition Switch                            | 38. Steering Shaft      |
| 5. Cancelling Cam              | 16. Shaft Lock Bolt              | 28. Mast Jacket                                | 39. Pot Joint Bolt      |
| 6. Bearing Preload Spring      | 17. Switch Rod and Rack Assembly | 29. Neutral Safety or Back-Up Switch Retainers | 40. Nut                 |
| 7. Turn Signal Screws          | 18. Thrust Cap                   | 30. Shift Tube                                 | 41. Pot Joint Cover     |
| 8. Turn Signal Switch          | 19. Shaft Lock Bolt Washer       | 31. Thrust Spring Washer                       | 42. Seal Retaining Ring |
| 9. Protector Cover             | 20. Shift Lever Detent Plate     | 32. Shift Tube Thrust Spring                   | 43. Bearing Spring      |
| 10. Turn Signal Housing Screws | 21. Detent Plate Screws          | 33. Lower Bearing Adapter                      | 44. Bearing Blocks      |
| 11. Bearing Thrust Washer      | 22. Shift Lever Spring           | 34. Lower Bearing Reinforcement                | 45. Pot Joint Seal      |
|                                | 23. Gearshift Lever Housing      |  | 46. Intermediate Shaft  |

Fig. 64—Standard Steering Column Explode Typical C and K

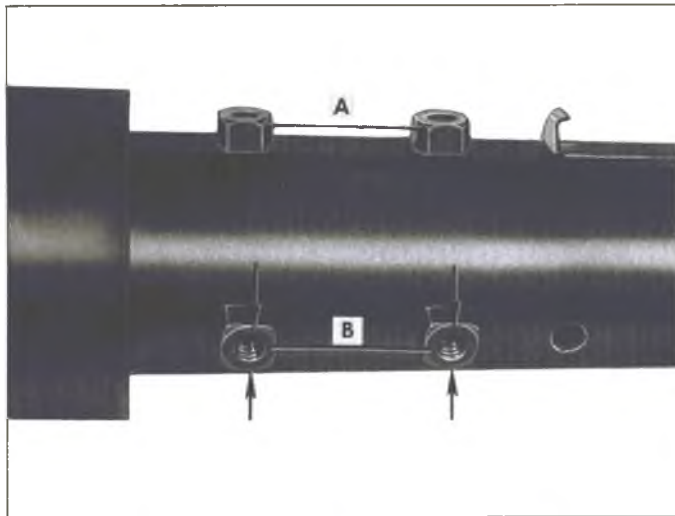

Fig. 65—Installing Steering Column in Vise

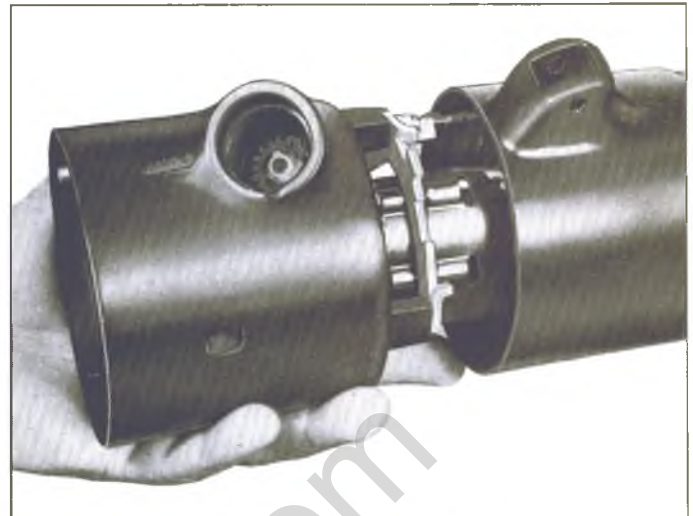

Fig. 66—Removing Turn Signal Housing

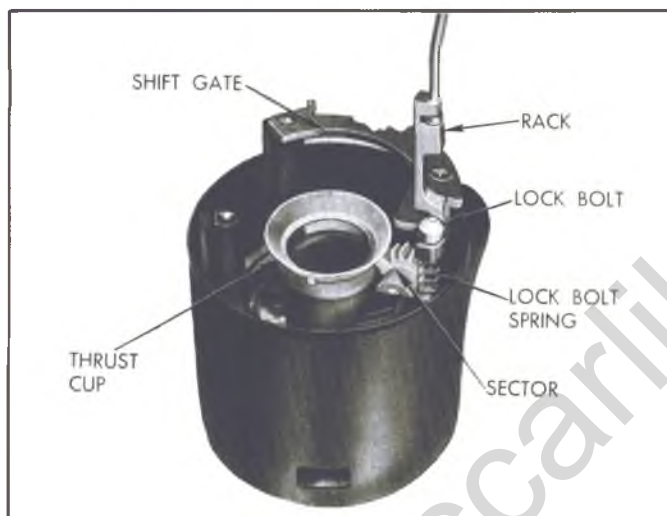

Fig. 67—Turn Signal Housing Assembly

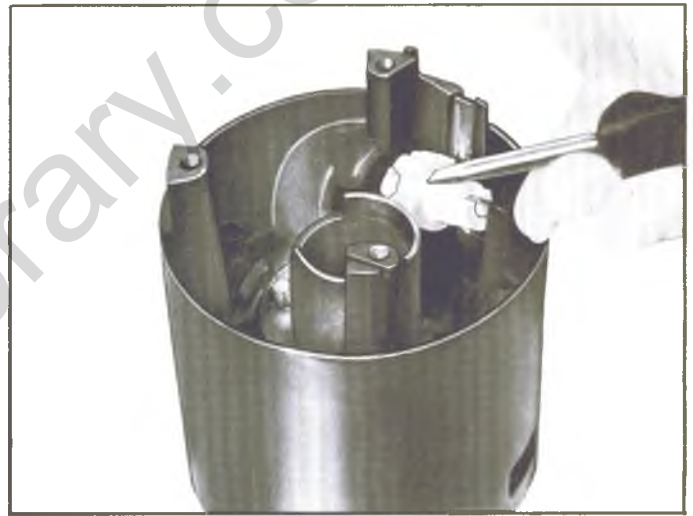

Fig. 68—Removing Ignition Switch Actuator Sector

pressure on the bearing outer race. Slide out the shift tube assembly.

**Manual Transmission — Column Shift —** Remove the lower bearing adapter, bearing and the first-reverse shift lever. The lower bearing may be removed from the adapter by light pressure on the bearing outer race. Remove the three screws from bearing at the lower end and slide out the shift tube assembly.

Remove the gearshift housing lower bearing from the upper end of the mast jacket.

## ASSEMBLY—ALL EXCEPT TILT COLUMNS

**NOTE:** Apply a thin coat of lithium soap grease to all friction surfaces.

1. Install the sector into the turn signal and lock cylinder housing. Install the sector in the lock cylinder hole over the sector shaft with the tang end

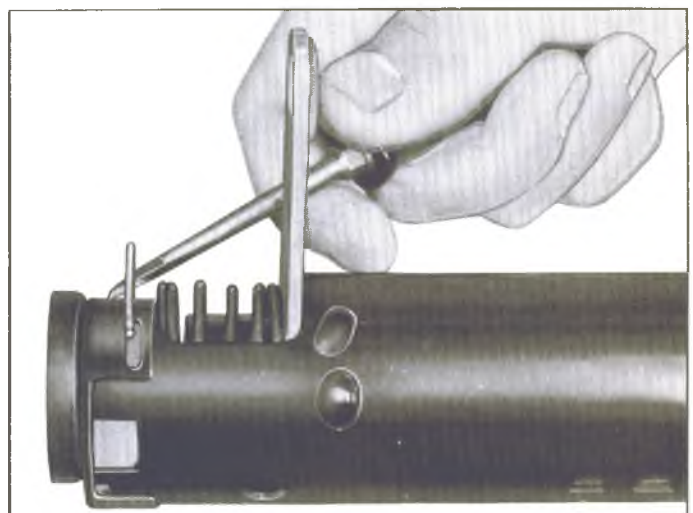

Fig. 69—Removing Lower Bearing Retainer



Fig. 70—Installing Rack Preload Spring

to the outside of the hole. Press the sector over the shaft with a blunt tool.

2. Install the shift lever detent plate onto the housing.
3. Insert the rack preload spring into the housing from the bottom side. The long section should be toward the handwheel and hook onto the edge of the housing (fig. 70).
4. Assemble the locking bolt onto the crossover arm on the rack and insert the rack and lock bolt assembly into the housing from the bottom with the teeth up (toward hand-wheel) and toward the centerline of the column (fig. 67). Align the 1st tooth on the sector with the 1st tooth on the rack; if aligned properly, the block teeth will line up when the rack assembly is pushed all the way in.
5. Install the thrust cup on the bottom hub of the housing.
6. Install the gearshift housing lower bearing. Insert



Fig. 71—Installing Gearshift Housing Lower Bearing

the bearing from the very end of the jacket. Aligning the indentations in the bearing with the projections on the jacket (fig. 71).

**CAUTION:** *If the bearing is not installed correctly, it will not rest on all of the stops provided.*

7. Install the shift lever spring into the gearshift lever (or lock tube) housing. Install the housing and shroud assemblies onto the upper end of the mast jacket. Rotate the housing to be sure it is seated in the bearing.
8. With the shift lever housing in place, install the turn signal and lock cylinder housing onto the jacket. The gearshift housing should be in "Park" position and the rack pulled downward. Be sure the turn signal housing is seated on the jacket and drive the four screws.
9. Press the lower bearing into the adapter assembly.
10. Insert the shift tube assembly into the lower end of the jacket and rotate until the upper shift tube key slides into the housing keyway.
11. **Automatic and Floorshift Columns** — Assemble the spring and lower bearing and adapter assembly into the bottom of the jacket. Holding the adapter in place, install the lower bearing reinforcement and retainer clip. Be sure the clip snaps into the jacket and reinforcement slots.
12. **Manual Transmission — Column Shift** — Loosely attach the three screws in the jacket and shift tube bearing.

Assemble the 1st-Reverse lever and lower bearing and adapter assembly into the bottom of the jacket. Holding the adapter in place, install the bearing reinforcement and retaining clip. Be sure the retaining clip snaps into the jacket and reinforcement slots.

Place a .005" shim between the 1st-Reverse lever and lever spacer and turn the upper shift tube

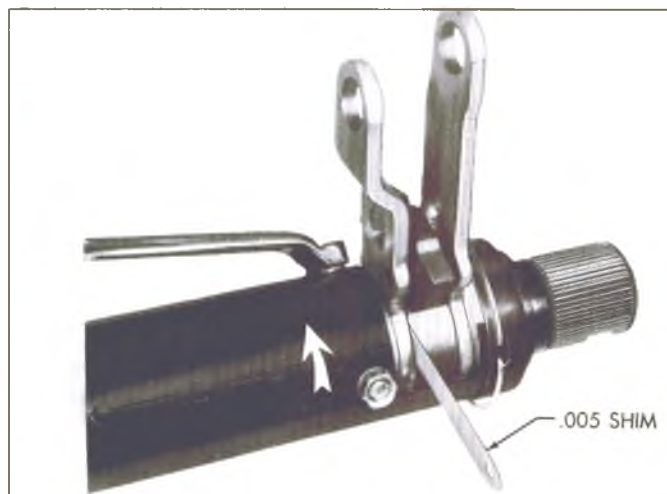

Fig. 72—Adjusting Lower Bearing - Typical

bearing down and tighten the three screws. Remove the shim (fig. 72).

13. Install the neutral-safety or back-up switch as outlined in Section 12 of this manual.
14. Slide the steering shaft into the column and install the upper bearing thrust washer.
15. Install the turn signal switch, lock cylinder assembly and ignition switch as previously outlined in this section.
16. Install the shift lever and shift lever pivot pin.
17. Remove the column from the vise.
18. Install the dash bracket to the column; torque the screws to specifications.

### DISASSEMBLY—TILT COLUMNS (Fig. 73)

**NOTE:** Steps 3-14 may be performed with the steering column in the vehicle.

1. Remove the four screws retaining the dash mounting bracket to the column and set the bracket aside to protect the breakaway capsules.
2. Mount the column in a vise using both weld nuts of either Set A or B as shown in Figure 65. The vise jaws must clamp onto the sides of the weld nuts indicated by arrows shown on Set B.

**CAUTION:** Do not place the column in a vise by clamping onto only one weld nut, by clamping onto one weld nut of both Sets A and B or by clamping onto the sides not indicated by arrows, since damage to the column could result.

3. Remove the directional signal switch, lock cylinder and ignition switch as outlined previously in this section.
4. Remove the tilt release lever. Drive out the shift lever pivot pin and remove the shift lever from the housing.
5. Remove the three turn signal housing screws and remove the housing.
6. Install the tilt release lever and place the column in the full "up" position. Remove the tilt lever spring retainer using a #3 phillips screwdriver that just fits into the slot opening. Insert the phillips screwdriver in the slot, press in approximately 3/16", turn approximately 1/8 turn counter-clockwise until the ears align with the grooves in the housing and remove the retainer, spring and guide (fig. 74).
7. Remove the pot joint to steering shaft clamp bolt and remove the intermediate shaft and pot joint assembly.

Push the upper steering shaft in sufficiently to remove the steering shaft upper bearing inner race and seat. Pry off the lower bearing retainer clip and remove the bearing reinforcement, bearing and

bearing adapter assembly from the lower end of the mast jacket.

8. Remove the upper bearing housing pivot pins using Tool J-21854-1 (fig. 75).
9. Install the tilt release lever and disengage the lock shoes. Remove the bearing housing by pulling upward to extend the rack full down, and then moving the housing to the left to disengage the ignition switch rack from the actuator rod.
10. Remove the steering shaft assembly from the upper end of the column.
11. Disassemble the steering shaft by removing the centering spheres and the anti-lash spring.
12. Remove the transmission indicator wire, if so equipped.
13. Remove the four steering shaft bearing housing support to gearshift housing screws and remove the bearing housing support. Remove the ignition switch actuator rod.
14. Remove the shift tube retaining ring with a screwdriver and then remove the thrust washer.
15. Install Tool J-23072 into the lock plate, making sure that the tool screws have good thread engagement in the lock plate. Then, turning the center screw clockwise, force the shift tube from the housing (fig. 76). Remove the shift tube (transmission control lock tube on floor shift models) from the lower end of the mast jacket. Remove Tool J-23072.

**CAUTION:** When removing the shift tube, be sure to guide the lower end through the slotted opening in the mast jacket. If the tube is allowed to interfere with the jacket in any way, damage to the tube and jacket could result.

16. Remove the bearing housing support lock plate by sliding it out of the jacket notches, tipping it down toward the housing hub at the 12 o'clock position and sliding it under the jacket opening. Remove the wave washer.
17. **All Columns** - Remove the shift lever housing from the mast jacket (transmission control lock tube housing on floor shift models). Remove the shift lever spring by winding the spring up with pliers and pulling it out. On floor shift models, remove the spring plunger.
18. Disassemble the bearing housing as follows:
  - a. Remove the tilt lever opening shield.
  - b. Remove the lock bolt spring by removing the retaining screw and moving the spring clockwise to remove it from the bolt (fig. 77).
  - c. Remove the snap ring from the sector drive shaft. With a small punch, lightly tap the drive shaft from the sector (fig. 78). Remove the drive shaft, sector and lock bolt. Remove the rack and rack spring.

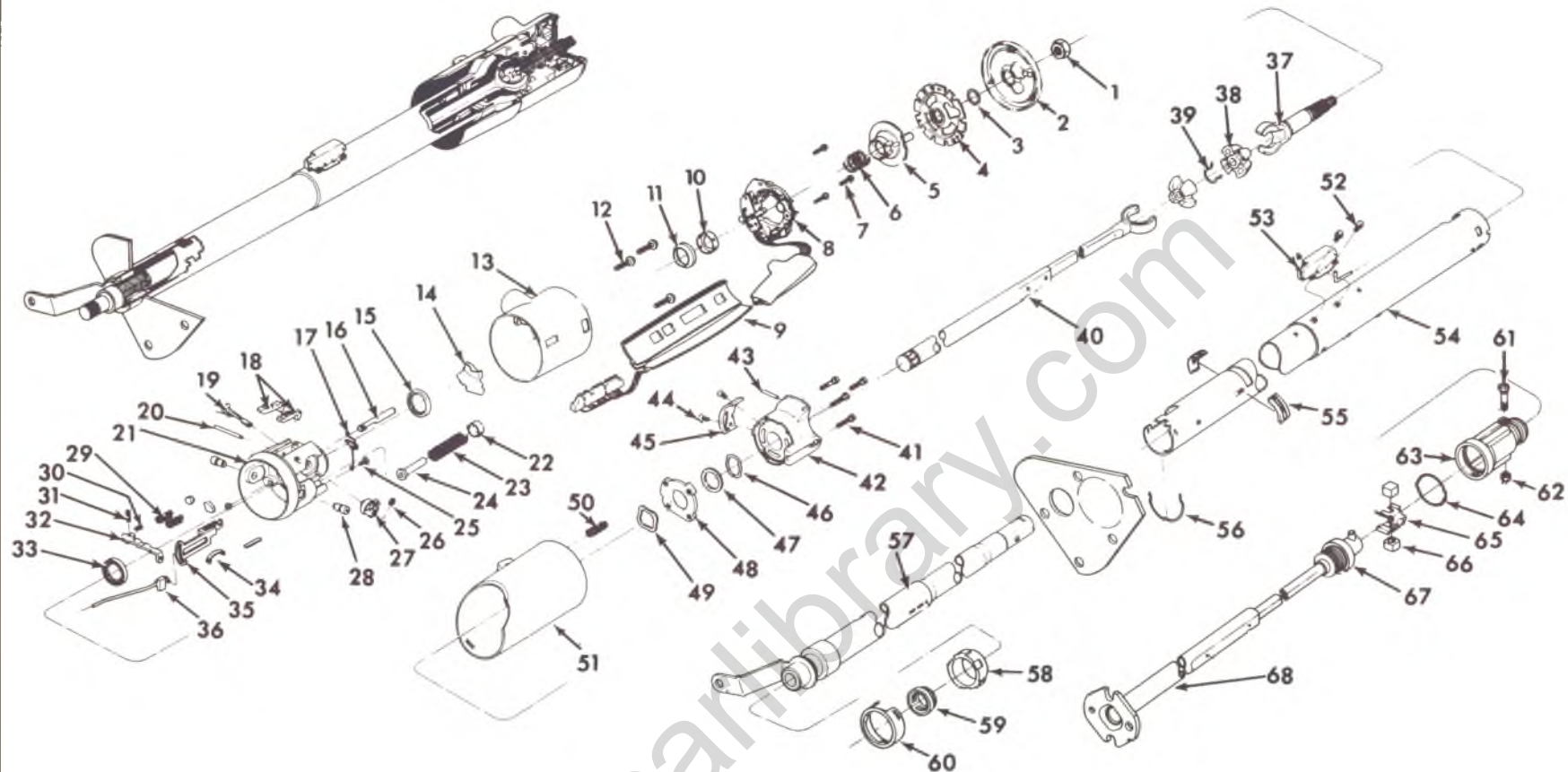

- |                                |                                 |                                    |                                 |
|--------------------------------|---------------------------------|------------------------------------|---------------------------------|
| 1. Shaft Nut                   | 17. Lock Bolt Spring            | 35. Ignition Switch Rack           | 53. Ignition Switch             |
| 2. Cover                       | 18. Lock Shoes                  | 36. Ignition Switch Rod            | 54. Mast Jacket                 |
| 3. Lock Plate Retaining Ring   | 19. Sector Shaft                | 37. Upper Steering Shaft           | 55. Neutral-Safety or Back-Up   |
| 4. Lock Plate                  | 20. Lock Shoe Pin               | 38. Centering Spheres              | 56. Retainer                    |
| 5. Cancelling Cam              | 21. Bearing Housing             | 39. Center Sphere Spring           | 57. Shift Tube                  |
| 6. Bearing Preload Spring      | 22. Tilt Lever Spring Retainer  | 40. Lower Steering Shaft           | 58. Lower Bearing Adapter       |
| 7. Turn Signal Screws          | 23. Tilt Lever Spring           | 41. Bearing Housing Support Screws | 59. Lower Bearing               |
| 8. Turn Signal Switch          | 24. Tilt Lever Spring Guide     | 42. Bearing Housing Support        | 60. Lower Bearing Reinforcement |
| 9. Protector Cover             | 25. Lock Bolt Spring Screw      | 43. Pin                            | 61. Pot Joint Bolt              |
| 10. Upper Bearing Seat         | 26. Sector Snap Ring            | 44. Shift Tube Index Plate Screws  | 62. Nut                         |
| 11. Upper Bearing Race         | 27. Sector                      | 45. Shift Tube Index Plate         | 63. Pot Joint Cover             |
| 12. Turn Signal Housing Screws | 28. Bearing Housing Pivot Pine  | 46. Support Retaining Ring         | 64. Seal Retaining Ring         |
| 13. Turn Signal Housing        | 29. Shoe Release Springs        | 47. Support Thrust Washer          | 65. Bearing Spring              |
| 14. Tilt Lever Opening Shield  | 30. Spring                      | 48. Support Plate Lock             | 66. Bearing Blocks              |
| 15. Upper Bearing              | 31. Shoe Release Lever Pin      | 49. Support Wave Washer            | 67. Pot Joint Seal              |
| 16. Shaft Lock Bolt            | 32. Shoe Release Lever          | 50. Gearshift Lever Spring         | 68. Intermediate Shaft          |
|                                | 33. Lower Bearing               | 51. Gearshift Lever Housing        |                                 |
|                                | 34. Ignition Switch Rack Spring | 52. Ignition Switch Screws         |                                 |

Fig. 73—Tilt Steering Column Assembly (Typical C and K)

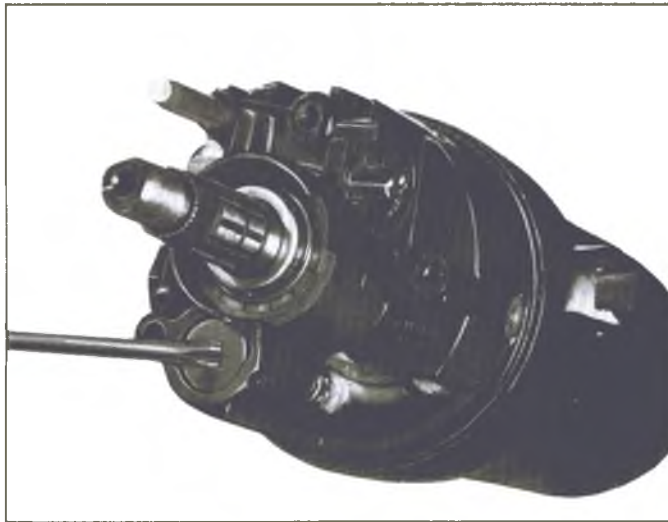

Fig. 74—Removing Tilt Lever Spring Retainer

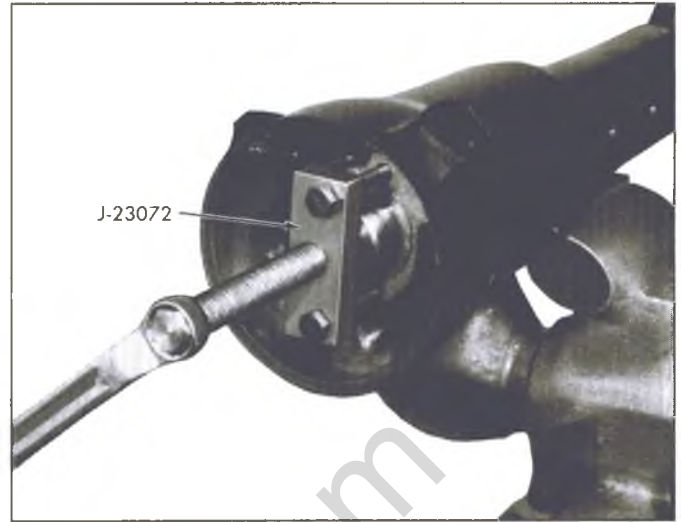

Fig. 76—Removing Shift Tube



Fig. 75—Removing Bearing Housing Pivot Pins

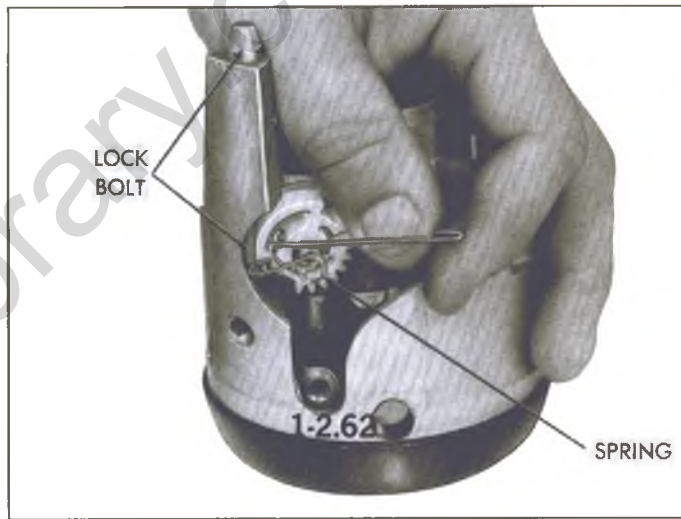

Fig. 77—Replacing Lock Bolt Spring

- d. Remove the tilt release lever pin with a punch and hammer. Remove the lever and release lever spring. To relieve the load on the release lever, hold the shoes inward and wedge a block between the top of the shoes (over slots) and bearing housing.
- e. Remove the lock shoe retaining pin with a punch and hammer. Remove the lock shoes and lock shoe springs.

NOTE: With the tilt lever opening on the left side and shoes facing up, the four slot shoe is on the left.

- f. Remove the bearings from the bearing housing only if they are to be replaced. Remove the separator and balls from the bearings. Place the housing on work bench and with a pointed punch against the back surface of the race, carefully hammer the race out of the housing

until a bearing puller can be used. Repeat for the other race.

### ASSEMBLY—TILT COLUMNS

Apply a thin coat of lithium grease to all friction surfaces.

1. If the bearing housing was disassembled, repeat the following steps:
  - a. Press the bearings into the housing, if removed, using a suitable size socket. Be careful not to damage the housing or bearing during installation.
  - b. Install the lock shoe springs, lock shoes and shoe pin in the housing. Use an approximate .180" rod to line up the shoes for pin installation.
  - c. Install the shoe release lever, spring and pin.

NOTE: To relieve the load on the release lever, hold the shoes inward and wedge a

10. Install the steering shaft assembly into the shift tube from the upper end. Carefully guide the shaft through the shift tube and bearing.
11. Install the ignition switch actuator rod through the shift lever housing and insert in the slot in the bearing support. Extend the rack downward from the bearing housing.
12. Assemble the bearing housing over the steering shaft and engage the rack over the end of the actuator rod (fig. 80).
13. With the external release lever installed, hold the lock shoes in the disengaged position and assemble the bearing housing over the steering shaft until the pivot pin holes line up.
14. Install the pivot pins.
15. Place the bearing housing in the full "up" position and install the tilt lever spring guide, spring and spring retainer. With a suitable screw driver, push the retainer in and turn clockwise to engage in the housing.
16. Install the upper bearing inner race and race seat.
17. Install the tilt lever opening shield.
18. Remove the tilt release lever, install the turn signal housing and torque the three retaining screws to 45 in. lbs.
19. Install the tilt release lever and shift lever. Drive the shift lever pin in.
20. Install the lock cylinder, turn signal switch and ignition switch as outlined previously in this section.
21. Align the groove across the upper end of the pot joint with the flat on the steering shaft. Assemble the intermediate shaft assembly to the upper shaft. Install the clamp and bolt and torque the nut to specifications.

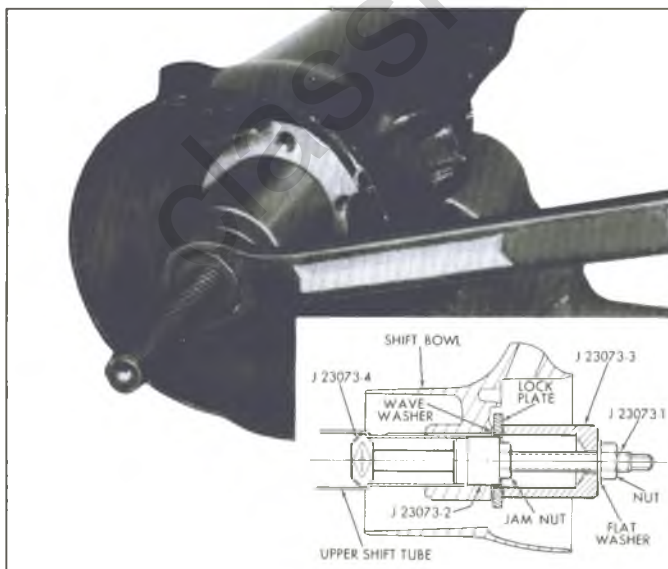

Fig. 81—Installing Shift Tube

NOTE: The clamp bolt must pass through the shaft under cut.

22. Install the neutral-safety switch or back-up switch as outlined in Section 12 of this manual.
23. Install the four dash panel bracket to column screws and torque to specifications.

**CAUTION:** Be sure that the slotted openings in the bracket (for the mounting capsules) face the upper end of the steering column.

## COLUMN INSTALLATION-MANDATORY SEQUENCE

### C and K SERIES VEHICLES (Fig. 82)

#### Mandatory Instructions

1. Assemble lower dash cover (A) and upper dash cover (B) to seal (C) with "Carrots" (part of seal).
2. Attach bracket (D) to jacket and tighten four bolts (E) to specified torque.

#### Mandatory Installation Sequence

1. Position column in body and position flange to rag joint and install lock washers and nuts (F) (May be tightened to specified torque at this time).

NOTE: Coupling (G) on manual steering must be installed prior to column installation.

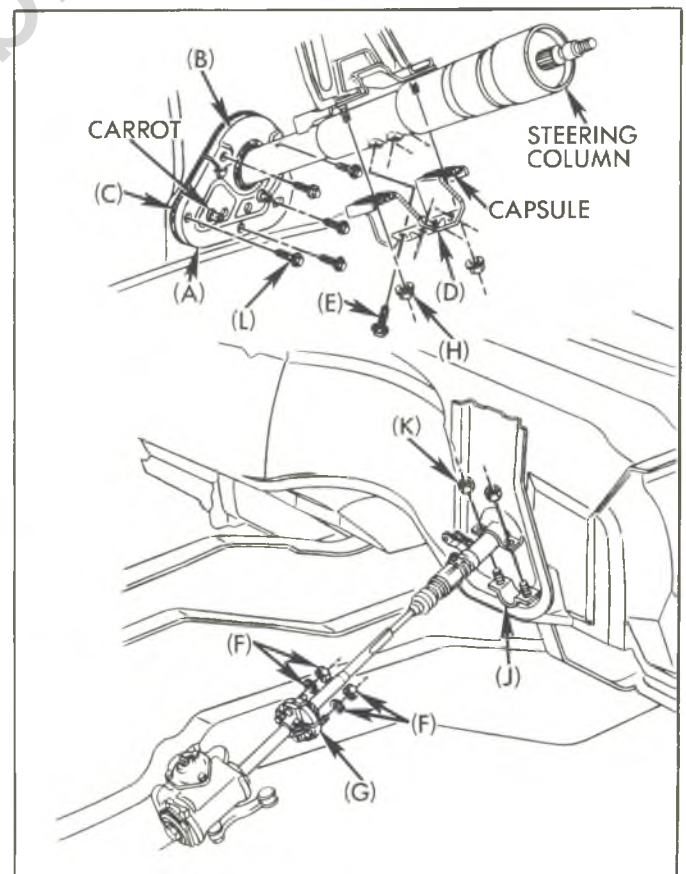

Fig. 82—Steering Column Installation (C and K)



## 9-48 STEERING

- Loosely assemble (2) capsule nuts (H) at the instrument panel bracket (D).
- Position lower clamp (J) and tighten attaching nuts (K) to specified torque.
- Tighten two nuts (H) at capsules to specified torque.
- Install seal (C) and covers (A and B) to dash.
- Install attaching screws (L) and tighten to specified torque.
- Tighten two nuts (F) at capsules to specified torque if not already done.
- Remove plastic spacers from flexible coupling pins.
- Install transmission indicator cable on column automatics.
- Install the instrument panel trim cover.
- Connect the transmission control linkage at the shift tube levers.
- Install the steering wheel as outlined previously in this section.
- Connect the battery ground cable.

### Mandatory System Requirements

- Pot joint operating angle must be  $1\ 1/2^\circ \pm 4^\circ$ .
- Flexible coupling must not be distorted greater than  $\pm .06$  due to pot joint bottoming, in either direction.

### STEERING COLUMN SERVICE FOR G AND P SERIES

#### STEERING COLUMN UPPER BEARING—G AND P SERIES

##### Standard Column

##### Removal

- Remove steering wheel as outlined in this section.
- Remove directional signal cancelling cam.
- Pry out upper bearing.

##### Installation

**CAUTION:** See *CAUTION* on page 1 of this section regarding the fasteners referred to in step 1.

- Replace all component parts in reverse order of removal making sure that directional signal switch is in neutral position before installing steering wheel. Torque steering wheel nut to specifications.

##### Tilt Column

The upper bearings on the tilt column are spun into the bearing housing assembly. If the bearings indicate need of replacement, the entire bearing housing must be replaced. See "Tilt Steering Column - Disassembly and Assembly" for the correct replacement procedure.

#### STEERING COLUMN LOWER BEARING P SERIES

##### Removal

- Remove the intermediate steering shaft and universal joint assembly as outlined earlier in this section. Remove the preload spring clamp and spring from the end of the steering shaft.
- Pry out the lower bearing assembly.

##### Installation

**CAUTION:** See *CAUTION* note on page 1 of this section regarding fasteners referred to in step 2.

- Place the new bearing over the end of the steering shaft and press into position in the column.
- Install the preload spring and clamp and torque the clamp bolt nut to specifications while maintaining the dimension shown in Figure 36. Reinstall the intermediate shaft and universal joint assembly as outlined under "Intermediate Steering Shaft with Universal Joint Couplings - Installation".

#### DIRECTIONAL SIGNAL SWITCH—G AND P SERIES COLUMNS

If the directional signal switch must be replaced, the steering column does not have to be removed from the vehicle.

##### Removal

- Remove the steering wheel as outlined under "Steering Wheel - Removal".
- Remove the directional signal switch cancelling cam and spring.
- Remove the column to instrument panel trim plate (if so equipped).

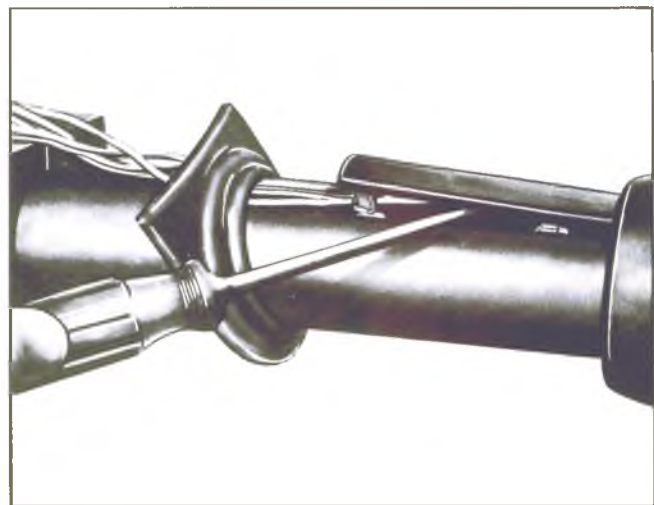

Fig. 83—Removing Wiring Harness Protector

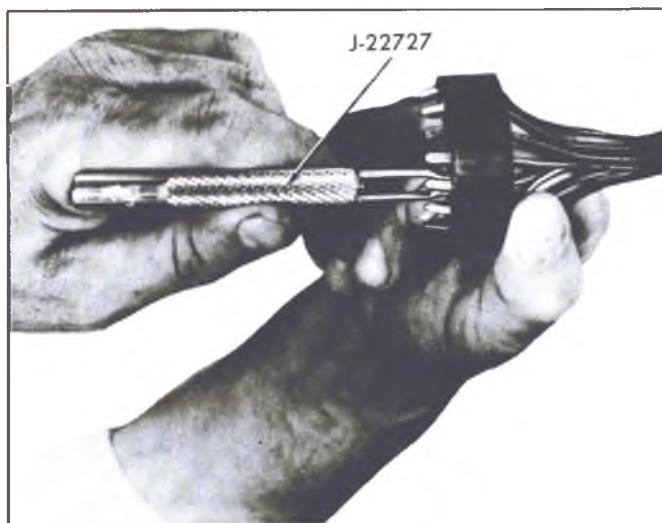

Fig. 84—Removing Wires from Connector

4. Disconnect the directional signal switch wiring harness at the half-moon connector.
5. Pry the wiring harness protector out of the column retaining slots as shown in Figure 83.
6. Mark the location of each wire in the half-moon connector and then remove each individual wire from the connector using Tool J-22727 (fig. 84). Insert the tool into the lower end of the connector and push in until the tool bottoms on the connector. Remove the tool and then pull the wire from the connector.
7. Remove the directional signal lever screw and remove the lever.
8. Push in on the hazard warning light knob and then unscrew and remove the knob.
9. Tilt Columns Only—
  - a. Automatic Transmission Models - Remove the PRNDL dial screws and remove the dial and indicator needle. Remove the cap and dial illumination bulb from the housing cover.
  - b. Unscrew and remove the tilt release lever.
  - c. Assemble Tool J-22708 inside the directional signal housing cover; push in until the tangs lock inside the cover flange (fig. 85). Turn the tool center screw clockwise to pull the cover from the housing.
10. Remove the three directional signal switch mounting screws and then carefully remove the switch assembly from the column while guiding the wiring harness through the opening in the shift lever housing.

#### Installation

**CAUTION:** See *CAUTION* on page 1 of this section regarding the fasteners referred to in step 9.

1. Wrap the ends of the directional signal switch wires

with tape and then guide them through the opening at the lower left hand side of the bearing housing (tilt columns) out the lower end of the shift lever housing and under the dash seal.

2. Place the directional signal switch in position and install the three mounting screws; torque to 25 in. lbs. after screw head has been firmly seated.
3. **Tilt Columns Only—**
  - a. Align the openings in the directional signal switch cover with the proper lever positions and tap the cover into place using a plastic hammer.
  - b. Install the tilt release lever.
  - c. Automatic Transmission Models - Install the PRNDL dial, pointer, dial illumination bulb and cap.
4. Install the directional signal switch lever and hazard warning knob.

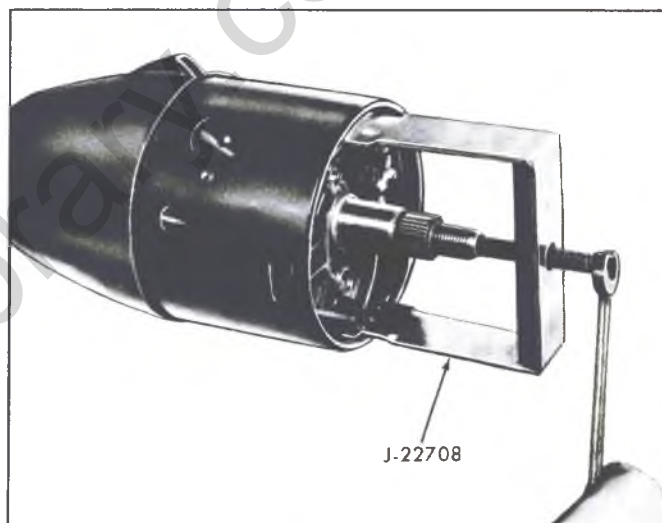

Fig. 85—Removing Directional Signal Housing Cover

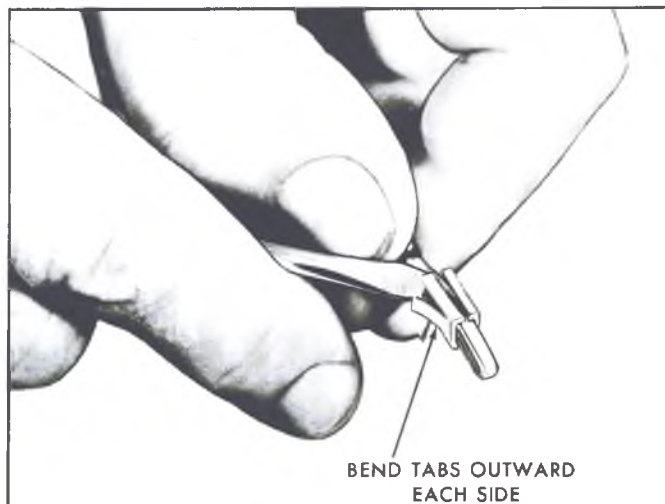

Fig. 86—Preparing Wire Retaining Tabs for Installation

## 9-50 STEERING

5. Bend the wire retaining tabs slightly outward on each wire in the wiring harness as shown in Figure 86; this will provide proper retention of the wire in the half-moon connector.
6. Install each wire in its marked location in the half-moon connector. Push in until square part of clip is flush with the bottom side of the connector. Connect the directional signal switch wiring harness.
7. Snap the wiring harness protector into the column retaining slots.
8. Install the directional signal cancelling cam and spring.
9. Install the steering wheel as outlined under "Steering Wheel - Installation".
10. Install the column to instrument panel trim plate (if so equipped).

### TILT COLUMN BEARING HOUSING ASSEMBLY - G AND P SERIES

#### Removal (Column in Vehicle)

1. Disconnect the battery ground cable.
2. Remove the steering wheel as outlined under "Steering Wheel - Removal".
3. Remove the directional signal switch as outlined under "Directional Signal Switch - Removal".
4. **Column Shift Models-** Using a suitable size punch, drive out the shift lever pivot pin and remove the shift lever.
5. Install the tilt release lever and place the column in the full "up" position. Remove the tilt lever spring and retainer using a screwdriver that just fits into the slot opening. Insert the screwdriver into the slot, push in approximately 3/16", rotate clockwise approximately 1/8 turn until the retainer ears align with the grooves in the housing and remove the retainer and spring.
6. Remove the steering shaft bearing locknut using Socket J-22599. Remove the upper bearing race seat and race.
7. Remove the two bearing housing pivot pins using Tool J-21854.
8. Pull up on the tilt release lever (to disengage the lock shoes) and remove the bearing housing.

If the bearing housing is being replaced or it is necessary to disassemble the bearing housing, proceed as follows:

- a. Press the upper and lower bearings out of the housing.
- b. Using Puller J-5822 and Slide Hammer J-2619, pull the bearing races from the housing.
- c. Remove the tilt release lever.
- d. Drive out the shoe release pivot pin using Tool

J-22635 or a suitable punch. Remove the lever spring and remove the wedge.

- e. Using a suitable size punch, drive out the lock shoe retaining pin. Remove the shoes and shoe springs.

If the upper steering shaft, lower steering shaft, or centering spheres are being removed, proceed as follows:

9. To remove the steering shaft assembly through the upper end of the column. If it is necessary to disassemble the shaft, proceed as follows:
  - a. To remove the lower steering shaft first disconnect the shaft at the pot joint coupling clamp.
  - b. Turn the upper shaft 90° to the lower shaft and slide the upper shaft and centering spheres from the lower shaft.
  - c. Rotate the centering spheres 90° and remove the centering spheres and preload spring from the upper shaft.

If the bearing housing support is being replaced, proceed as follows:

10. Remove the four bearing housing support screws and remove the support.

#### Assembly

**CAUTION:** See caution note on page 7 of this section regarding the fasteners referred to in steps 3, 9 and 11.

1. Assemble the steering shaft as follows:
  - a. Lubricate and assemble the centering spheres and preload spring.
  - b. Install the spheres into the upper (short) shaft and rotate 90°.
  - c. Install the lower shaft 90° to the upper shaft and over the centering spheres. Slowly straighten the shafts while compressing the preload spring.
2. Install the shaft assembly into the housing from the upper end.
3. Install the lower shaft to the pot joint coupling clamp. Install the coupling clamp bolt and torque to specifications.

NOTE: The coupling bolt must pass through the shaft undercut.

4. Assemble the bearing housing as follows:
  - a. Press the new upper and lower bearing races into the bearing housing.
  - b. Lubricate and install the bearings into the bearing races.
  - c. Place the lock shoe springs in position in the housing. Install each shoe in place and compress the spring until a suitable size straight punch can be used to hold the shoe in position (it may

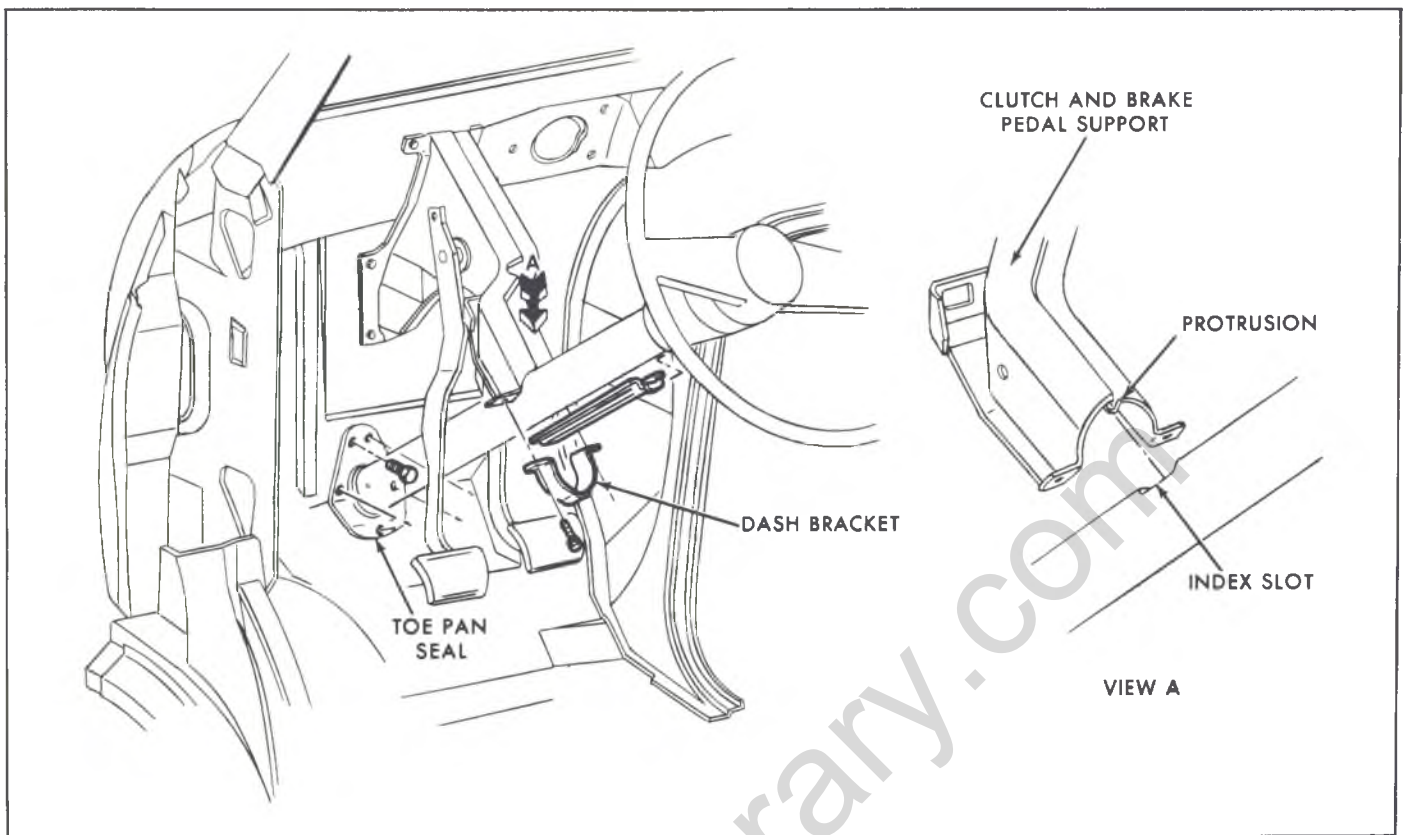

Fig. 87—Steering Column Installation-G Series

- d. Install the shoe release lever and drive in the pivot pin.
- e. Install the tilt release lever.
- f. Lubricate the shoes and release lever.
5. Install the bearing housing assembly to the support. Hold the tilt release lever in the "up" position until the shoes have fully engaged the support. Lubricate and install the bearing housing pivot pins. Press the pins in flush with the housing.
6. Place the housing in the full "up" position and then install tilt spring and retainer (tapered end of spring first). Push into the housing approximately 3/16" and rotate counterclockwise 1/8 turn.
7. Lubricate and install the upper bearing race, race seat and locknut. Tighten the locknut (using Socket J-22599) to remove the lash and then carefully further tighten 1/16 to 1/8 of a turn (column must be in straight ahead position).
8. Remove the tilt release lever.
9. Install the directional signal switch as outlined under "Directional Signal Switch - Installation".
10. Column Shift Models - Install the shift lever and pivot pin.
11. Install the steering wheel as outlined under "Steering Wheel - Installation".
12. Check electrical and mechanical functioning of column.

## STEERING COLUMN G AND P SERIES

### Removal (Fig. 87)

1. Disconnect the battery ground cable.
2. Column Shift Models - Disconnect transmission shifter rods at the lower end of the column.
3. G Models - Remove the steering shaft flange to flexible coupling bolts.  
P Models - Remove the intermediate steering shaft upper universal yoke to steering shaft pinch bolt. Mark the coupling to shaft relationship.
4. Remove column clamp screw(s) on engine side of firewall if equipped and remove or slide the clamp down the column.
5. From inside the vehicle, remove the screws from the toe pan cover and slide the cover and seal up the column.
6. Remove the steering wheel as outlined under "Steering Wheel-Removal," and reinstall the shaft nut and washer.
7. All Columns - Disconnect the directional signal wiring harness.

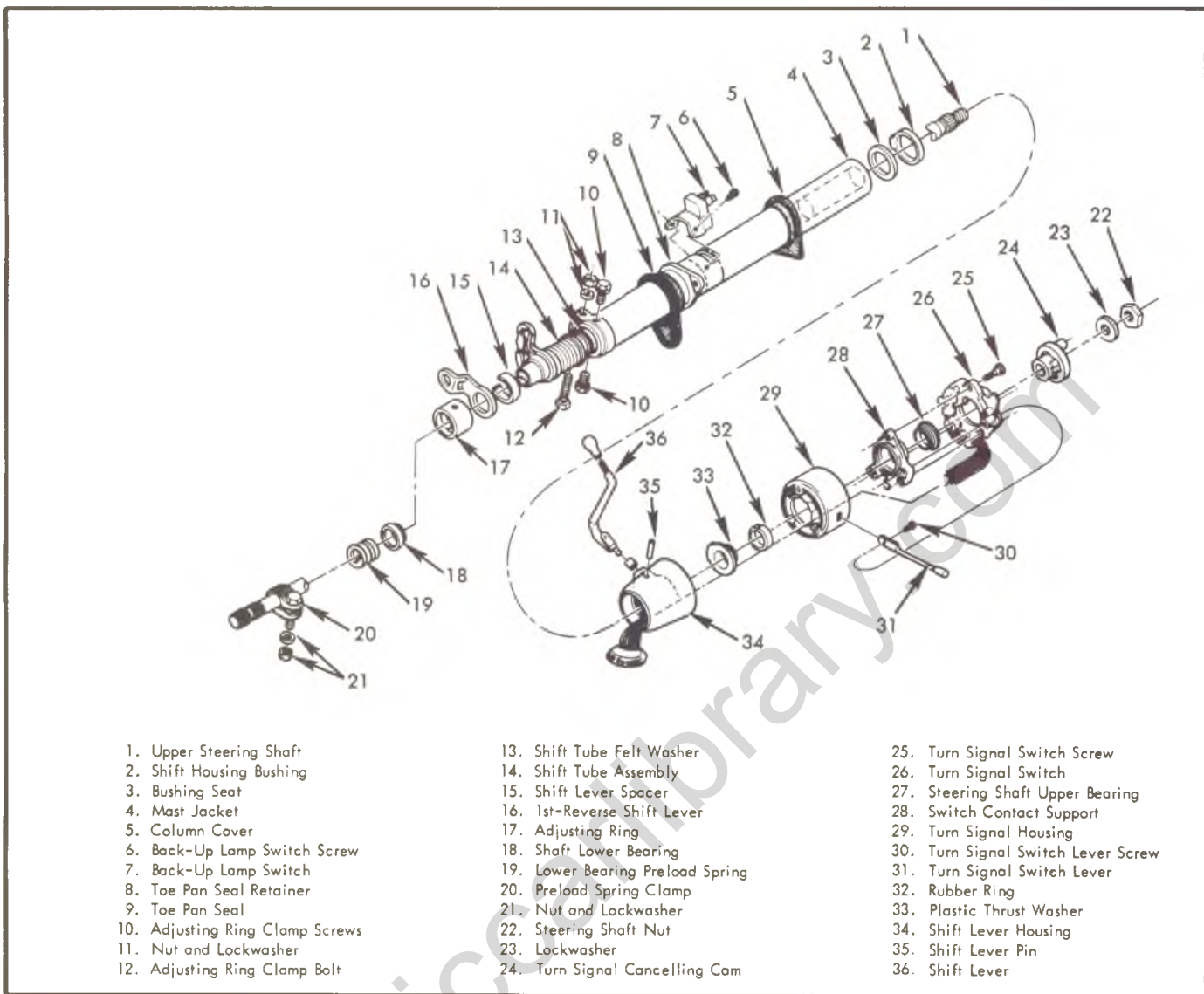

Fig. 88—Standard Column - Exploded (Typical G and P)

Standard Column with Automatic Transmission - Disconnect the conductor tube (for transmission indicator) at the instrument panel.

Tilt Column with Automatic Transmission - Disconnect the single wire at the fuse block and unclip it from the parking brake bracket.

8. Remove the cap screws from the column support bracket at the dash panel.
9. Carefully lower and then withdraw the column assembly, rotating so that the shift levers clear the toe pan opening.

#### Disassembly—Standard Column (Fig. 88)

NOTE: For floor shift transmission models, omit Steps 4, 14, 15 and 16.

1. Remove the steering wheel nut and lock washer and then slide the steering shaft assembly from the lower end of the column.

2. G Models - Remove the lower bearing preload spring and clamp from the steering shaft.  
 P Models - Remove the lower bearing preload spring and clamp.
3. Remove the back-up lamp switch.
4. Drive out the shift lever pivot pin and remove the shift lever.
5. Remove the directional signal cancelling cam. Remove the directional signal switch lever.
6. Remove the column wiring harness cover.
7. Remove the directional signal switch screws.
8. Rotate the directional signal switch housing counterclockwise and remove the housing from the column.

NOTE: The housing and switch cannot be fully removed from the column until the shift lever housing is removed.

9. Remove the plastic thrust washer assembly and then remove the shift lever housing (or extension housing) from the column.
10. Separate the directional signal switch, switch control support assembly, directional signal housing and shift lever housing (or housing extension) assemblies.
11. Press the steering shaft upper bearing out of the switch contact support.
12. Remove the shift lever housing (or extension housing) seat and bushing from the upper end of the column.
13. Remove the bolt and screws from the adjusting ring clamp and remove the clamp, adjusting ring and lower bearing. Press the lower bearing out of the adjusting ring.
14. 3-Speed Columns - Remove 1st-reverse shift lever and lever spacer.

Automatic Columns - Remove the selector plate clamping ring screws (3).

15. Place the column upright on the floor, supporting it with two pieces of wood. Place a block of wood on the upper end of the shift tube. Press down on the shift lever with foot while tapping on the wood block to withdraw the tube from the column jacket.

**NOTE:** In some tolerance stack-up cases it may be necessary to use a press. Be careful not to damage the tube or jacket.

16. Remove the felt seal from the shift tube.
17. Remove firewall clamp, toe pan seal and dash panel seals from the jacket.

### Assembly—Standard Column

**NOTE:** In the following assembly sequence use any general purpose lithium soap grease for lubricating those components so indicated.

1. Install the dash panel seal, toe panel and firewall clamps over the end of the jacket.
2. Lubricate all bearing surfaces on the shift tube.
3. Place the felt seal onto the shift tube (next to spring) and then place the shift tube in the jacket.
4. 3-Speed Columns - Temporarily install spacer, 1st-reverse shift lever and lower adjusting ring. Place a block of wood on top of the adjusting ring and tap until the shift tube bottoms. Remove adjusting ring, shift lever and spacer.

**NOTE:** The shift tube spring retainer must be bottomed against the jacket stops.

Automatic Columns - Align the three holes in the selector plate with the three holes in the jacket, position the clamping ring and install the three screws.

5. 3-Speed Columns - Lubricate and install the spacer

and 1st-reverse shift lever (tang of lever towards top of column).

6. Install lower bearing in the adjusting ring and then install the adjusting ring, clamp and screws.
7. Install the shift lever housing (or extension housing) seat and bushing to upper end of housing.
8. Thread directional signal switch wiring harness through the switch and shift lever (or extension) housings, lubricate the inner diameter of the shift housing, and then place the shift lever (or extension) housing onto the upper end of the column.
9. Install the switch housing plastic washer assembly. Press the upper bearing into the switch contact support.
10. Install the directional signal switch housing, contact support, bearing and switch and torque the switch screws to 25 in. lbs.
11. Install the column wiring harness cover and back-up lamp switch.
12. Install the directional signal and gearshift levers.
13. Adjust the shift tube as outlined under "Shifter Tube Adjustment."
14. Loosely install the lower bearing preload spring and clamp.
15. Slide the steering shaft assembly up through the column assembly. Install the directional signal cancelling cam, steering shaft nut and lock washer.

### Disassembly—Tilt Column (Fig. 89)

1. If the column is removed from the vehicle, place the column in a bench vise using Holding Fixtures J-22573 (fig. 90).

**CAUTION:** *Clamping the column directly in a vise, could result in a damaged column.*

2. Remove the directional signal switch as outlined under "Directional Signal Switch-Removal".
3. Remove the lower steering shaft and pot joint assembly and lower bearing and adapter assembly as outlined under "Lower Bearing and Adapter-Removal".
4. Column Shift Models - Using a suitable size punch, drive out the shift lever pivot pin and remove the shift lever.
5. Install the tilt release lever and place the column in the full "up" position. Remove the tilt lever spring and retainer using a screw driver that just fits into the slot opening (fig. 91). Insert the screw driver into the slot, push in approximately 3/16", rotate clockwise approximately 1/8 turn until the retainer ears align with the grooves in the housing and remove the retainer and spring.
6. Remove the steering shaft bearing locknut using

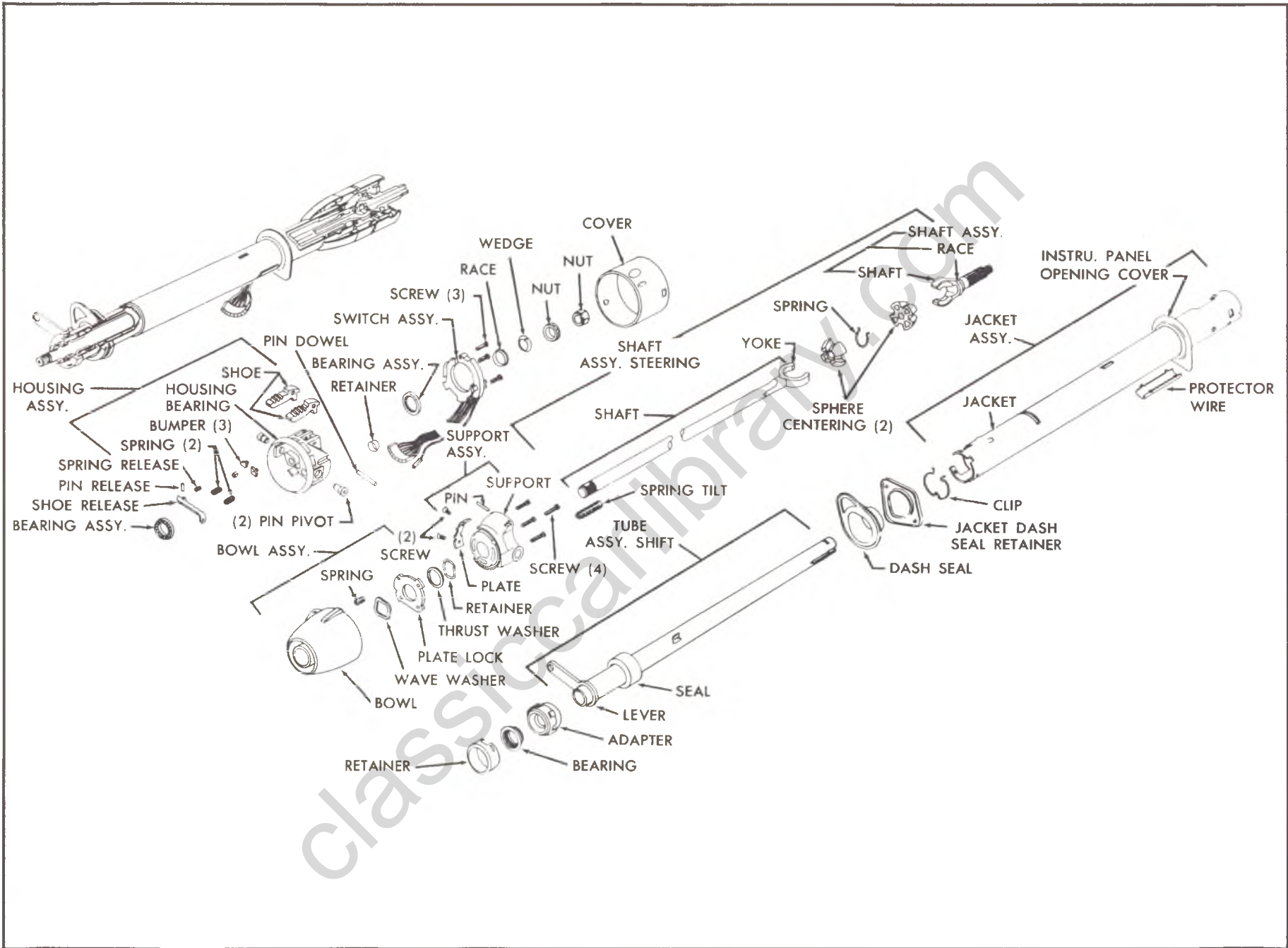

Fig. 89--Tilt Steering Column - G and P Series Explode

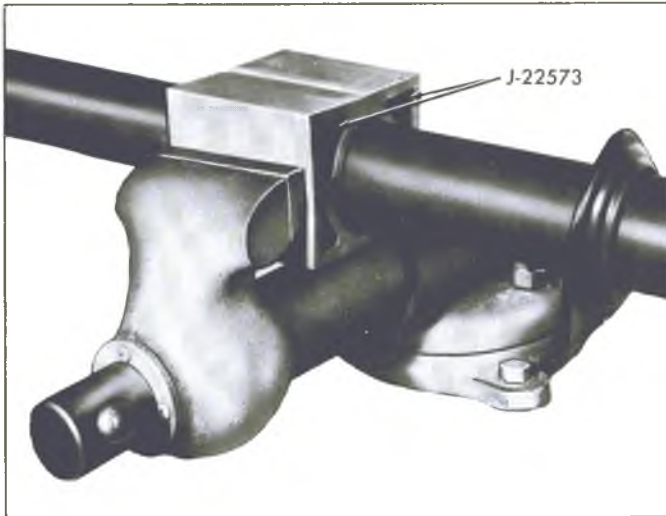

Fig. 90—Securing Column with J-22573

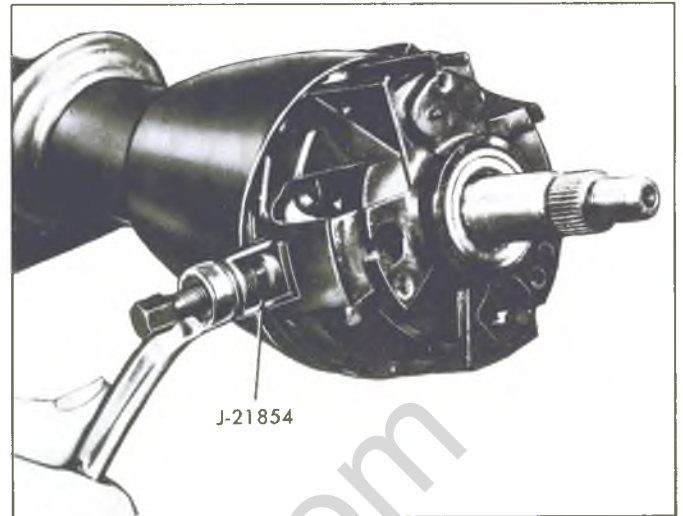

Fig. 92—Removing Bearing Housing Pivot Pin

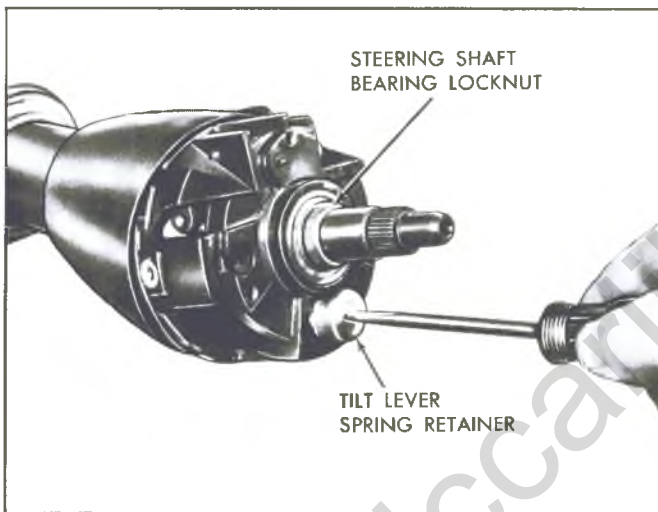

Fig. 91—Removing Tilt Spring and Retainer

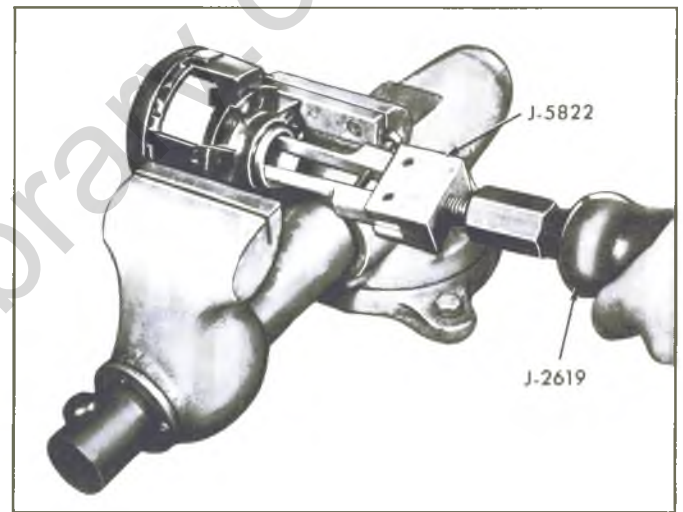

Fig. 93—Removing Bearing Race

socket J-22599. Remove the upper bearing race seat and race.

7. Remove the two bearing housing pivot pins using Tool J-21854 (fig. 92).
8. Pull up on the tilt release lever (to disengage the lock shoes) and remove the bearing housing. If it is necessary to disassemble the bearing housing, proceed as follows:
  - a. Press the upper and lower bearings out of the housing.
  - b. Using Puller J-5822 and Slide Hammer J-2619 pull the bearing races from the housing (fig. 93).
  - c. Remove the tilt release lever.
  - d. Drive out the shoe release lever pivot pin using Tool J-22635 or a suitable punch (fig. 94). Remove the lever spring and remove the wedge.
  - e. Using a suitable size punch, drive out the lock



Fig. 94—Removing Release Lever Pivot Pin



## 9-56 STEERING

shoe retaining pin. Remove the shoes and shoe springs.

9. Remove the steering shaft assembly through the upper end of the column. If it is necessary to disassemble the shaft proceed as follows:
  - a. Turn the upper shaft 90° to the lower shaft and slide the upper shaft and centering spheres from the lower shaft.
  - b. Rotate the centering spheres 90° and remove the centering spheres and preload spring from the upper shaft.
10. Remove the four bearing housing support screws and remove the support.

Column Shift Models - If the shift tube index plate must be removed, remove the two retaining screws and remove the plate.

11. Remove the shift tube retaining ring with a screw driver (fig. 95). Remove the thrust washer.
12. Remove the neutral-safety or back-up lamp switch screws and remove the switch.
13. Rework Shift Tube Removing Tool J-22551 by removing 1/2" from the pilot end of the tool (Fig. 96). This allows the shift tube to be pushed further out of the housing and will not affect the use of the tool on other columns.
14. Remove the shift tube assembly using Tool J-22551 (fig. 97). Insert the hooked end of the tool into the notch in the shift tube just below the shift lever housing key. Pilot the sleeve over the threaded end of the tool and into the upper end of the shift tube. Force the shift tube out of the housing by turning the nut onto the tool. If the shift tube is not completely free when the nut is bottomed on the threads, complete the removal by hand.

**CAUTION:** Do Not hammer or pull on the shift tube during removal. On column shift models, guide the lower shift lever through the slotted

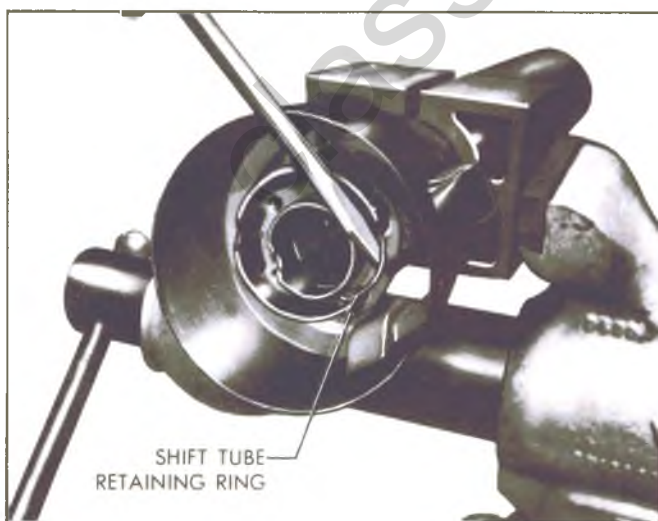

Fig. 95—Removing Shift Tube Retaining Ring

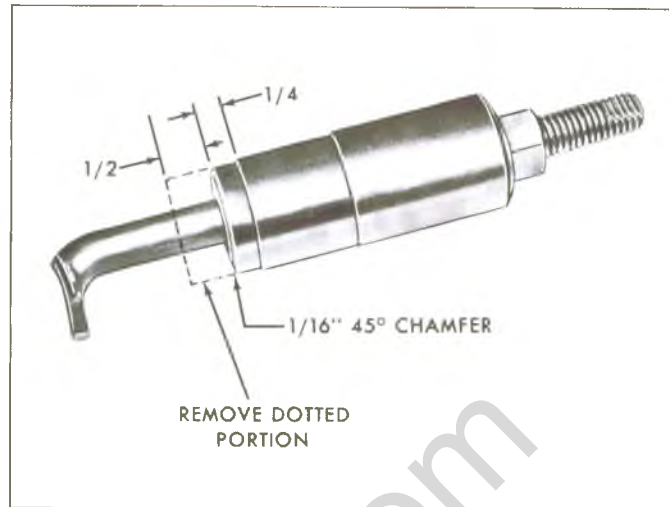

Fig. 96—Revised Shift Tube Removing Tool J-22551

*opening in the column to prevent damage to the tube or column.*

15. Remove the lock plate by sliding out of the column notches, tipping the plate downward toward the housing (to compress the wave washer) and then removing as shown in Figure 98. Remove the wave washer.
16. Remove the shift lever housing.
17. Column Shift Models - Remove the shift lever spring by winding the spring up with pliers.
18. If necessary, remove the dash panel seal, mounting plate and the instrument panel seal from the column jacket.

### Assembly—Tilt Columns

NOTE: When lubricating components during the following installation sequence, use any general purpose lithium soap grease.

1. Install the dash panel seal, mounting plate and the instrument panel seal on the column.
2. Column Shift Models - Press a new shift lever spring into the shift lever housing.
3. Slide the shift lever housing over the upper end of the column.
4. Place the wave washer and lock plate in position. Work the lock plate into the notches by tipping the plate toward the housing (compressing the wave washer) at the open side of the column. Lubricate the lock plate and upper end of the shift tube.
5. Carefully install the shift tube into the lower end of the column (make sure the foam seal is at the lower end of the shift tube). Align the keyway in the tube with the key in the shift lever housing and complete installation of the shift tube using Tool J-22549 (fig. 99). The shift lever housing key must bottom in the shift tube slot to be fully installed. Remove Tool

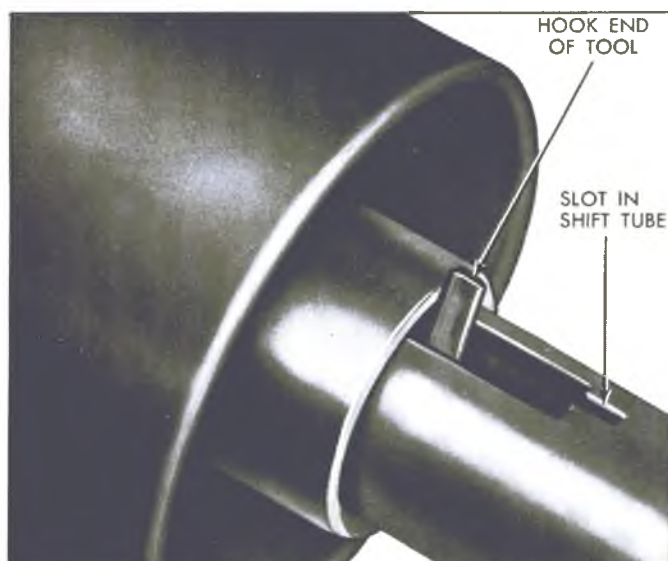

Fig. 97—Removing Shift Tube Assembly

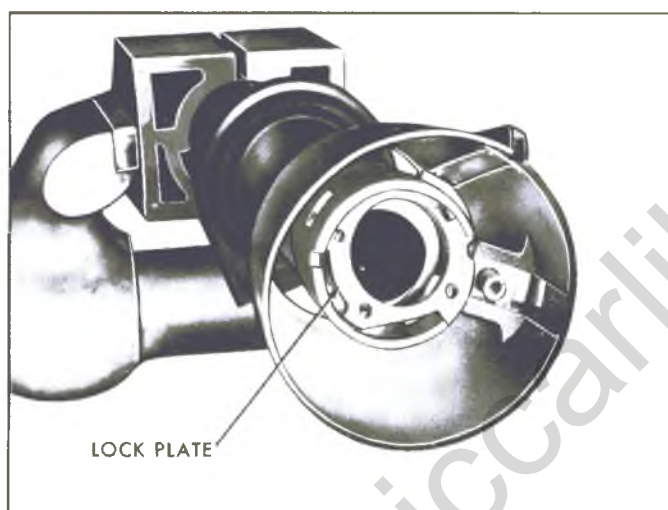

Fig. 98—Removing Lock Plate Assembly

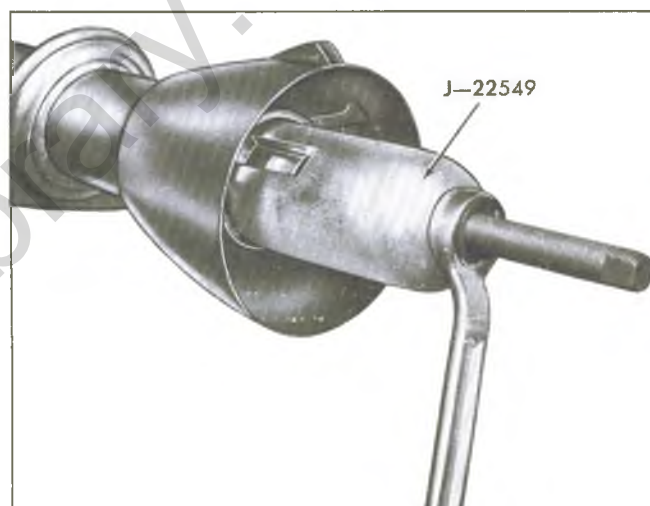

Fig. 99—Installing Shift Pin Tube

J-22549 from the column. Lubricate and push foam seal in flush with column housing.

**CAUTION:** Do Not hammer or force the tube when installing in the column.

6. Pull up on the shift lever housing (to compress the wave washer) and install the thrust washer and retaining ring. Be sure the ring is seated in both slots of the shift tube.
7. Lubricate the I.D. of the bearing housing support and install the support, aligning the bolt holes in the support with the bolt holes in the lock plate. Install the four support screws and torque to 45 in. lbs.
8. Assemble the steering shaft as follows:
  - a. Lubricate and assemble the centering spheres and preload spring.
  - b. Install the spheres into the upper (short) shaft and rotate 90°.
  - c. Install the lower shaft 90° to the upper shaft and over the centering spheres. Slowly straighten the shafts while compressing the preload spring.
9. Install the shaft assembly into the housing from the upper end.
10. Install the lower bearing and adapter, bearing reinforcement, wire clip, pot joint coupling and lower shaft as described under "Lower Bearing Installation".
11. Assemble the bearing housing as follows:
  - a. Press the new upper and lower bearing races into the bearing housing.
  - b. Lubricate and install the bearings into the bearing races.
  - c. Place the lock shoe springs in position in the

housing. Install each shoe in place and compress the spring until a suitable size straight punch can be used to hold the shoes in position (it may be necessary to acquire assistance to install the shoes). Once the shoes are in place, drive in the shoe retaining pin.

- d. Install the shoe release lever and drive in the pivot pin.
  - e. Install the tilt release lever.
  - f. Lubricate the shoes and release lever.
12. Install the bearing housing assembly to the support. Hold the tilt release lever in the "up" position until the shoes have fully engaged the support. Lubricate and install the bearing housing pivot pins. Press the pins in flush with the housing.
  13. Place the housing in the full "up" position and then install tilt spring and retainer (tapered end of spring first). Push into the housing approximately 3/16" and rotate counter clockwise 1/8 turn.
  14. Lubricate and install the upper bearing upper race, race seat and locknut. Tighten the locknut (using Socket J-22599) to remove the lash and then further tighten 1/16 to 1/8 of a turn (column must be in straight ahead position).
  15. Remove the tilt release lever.
  16. Install the directional signal switch as outlined under "Directional Signal Switch-Installation".
  17. Column Shift Models - Install the shift lever and pivot pin.
  18. Install the neutral-safety or back-up lamp switch.
  19. Remove the column from the bench vise.

**COLUMN INSTALLATION-MANDATORY SEQUENCE P SERIES (Fig. 87)**

**CAUTION:** See CAUTION note on page 1 of

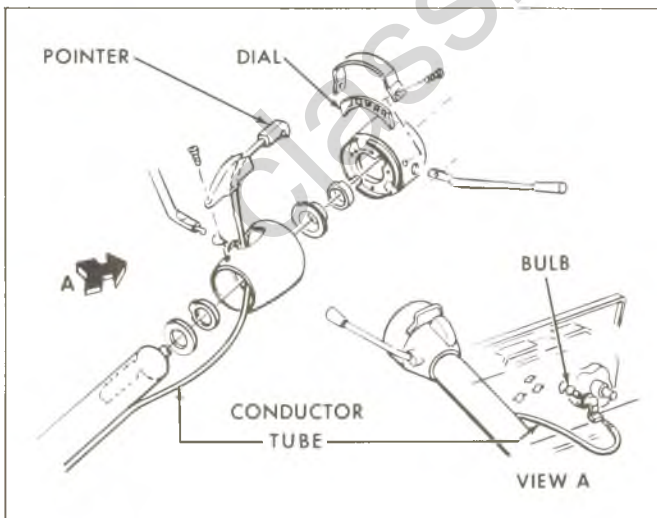

Fig. 100—Conductor Tube for Automatic Transmission Indicator

this section regarding the fasteners referred to in steps 1, 2, 3, and 10.

1. Applying 50 lbs. force on the steering wheel end of the steering shaft, adjust the lower bearing preload to allow steering shaft end play as indicated in Figure 36. Tighten the shaft clamp on pot joint bolt to specifications.
2. From the passenger side of the dash panel, carefully insert the lower end of the steering column through the toe panel opening.

Guide the steering shaft into the universal yoke, lining up the marks made at removal. Install the yoke pinch bolt and torque to specifications. The pinch bolt must pass through the shaft undercut.

3. Position and attach the lower clamp mounting bracket to the firewall. Locate the steering column protrusions against the toe pan bracket while at the same time, aligning protrusion in brake and clutch pedal support with index slot in the steering column, as shown in Figure 87. Install the column to bracket clamp and torque the clamp bolt to specifications.

NOTE: The toe pan bracket must not override the protrusions on the steering column.

4. Position the steering column to dash panel bracket, install the attaching bolts and torque to specifications.
5. If plastic spacers were used on the flexible coupling alignment pins, remove the spacers after all bolts have been properly torqued.
6. Install the seal at the toe pan and then install the toe pan bracket screws; torque to specifications.
7. Install the dash panel trim plate (if so equipped).
8. Connect the transmission shift linkage on column shift models.

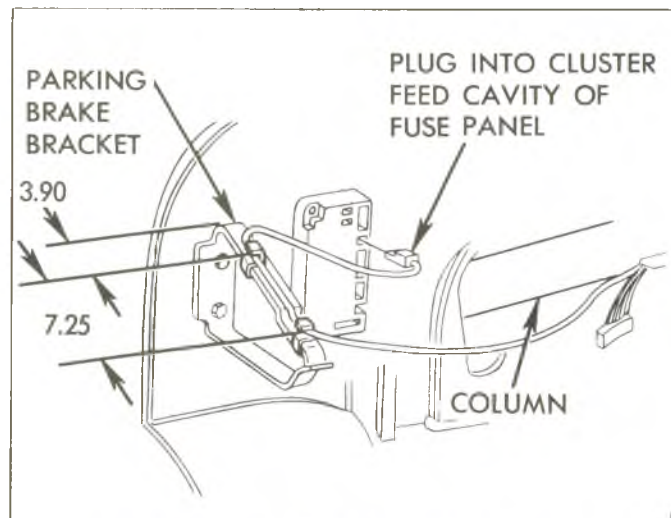

Fig. 101—Tilt Column Shift Indicator Light

9. All Columns - Connect the directional signal wiring harness.

Standard Column with Automatic Transmission - Connect the conductor tube (for transmission indicator) at the instrument panel (fig. 100).

10. Install steering wheel as outlined under "Steering Wheel-Installation".
11. Connect battery ground cable.

### Column Installation—Mandatory Sequence G Series

**CAUTION:** See *CAUTION* on page 1 of this section regarding the fasteners referred to in steps 3 and 10.

1. Adjust the column lower bearing preload by applying a force on the steering wheel end of the steering shaft (A). Position the spring and clamp to maintain the dimension as shown in Figure 36.
2. Install the plastic spacers onto the flexible coupling alignment pins.
3. From inside the vehicle, carefully insert the lower end of the column through the toe pan opening guiding the steering shaft flange onto the flexible coupling. Install and torque the flange to coupling bolts.
4. Locate the index slot in the column jacket with the protrusion on the clutch and brake pedal support.
5. Loosely install the column dash bracket and screws.
6. Push the column down until the steering shaft flange bottoms on the plastic spacers on the flexible coupling and then torque the dash bracket screws.
7. Remove the plastic spacer from the alignment pins using a wire hook. Check the rag joint to steering shaft flange clearance (.250" to .325"), if not within specifications, the dash bracket screws must be loosened and the column raised or lowered as required. Retorque the bracket screws.

**CAUTION:** The alignment pin plastic spacers must be removed before the vehicle can be driven.

8. Push the tow pan seal to the toe pan, install and torque the mounting screws.
9. All Columns Connect the directional signal switch wiring harness.  
Automatic Columns-Connect the conductor tube (for transmission indicator) to the instrument panel.
10. Install the steering wheel as outlined under "Steering Wheel Installation".
11. Connect the transmission linkage.
12. Connect the battery ground cable.

### STEERING LINKAGE

**CAUTION:** See *CAUTION* on page 1 of this section regarding all fasteners referred to in servicing steering linkage components.

#### Tie Rods

##### Removal

1. Raise vehicle on hoist.
2. Remove cotter pins from ball studs and remove castellated nuts.
3. To remove outer ball stud, tap on steering arm at tie rod end with a hammer while using a heavy hammer or similar tool as a backing (fig. 103).
4. Remove inner ball stud from relay rod using same procedure as described in Step 3.
5. To remove tie rod ends from tie rod, loosen clamp bolts and unscrew end assemblies.

##### Installation

**CAUTION:** See the *CAUTION* on page 1 of this section regarding the fasteners referred to in steps 4 and 6.

**NOTE:** Tie rod adjuster components often become rusted in service. In such cases, it is recommended that if the torque required to remove the nut from the bolt after breakaway exceeds 7 foot-pounds, discard the nuts and bolts. Apply penetrating oil between the clamp and tube and rotate the clamps until they move freely. Install new bolts and nuts having the same part number to assure proper clamping at the specified nut torque.

**CAUTION:** As a guide to correct orientation of the inner tie rod end relative to the outer tie rod end, rotate both ends to the extremes of travel in the same direction before clamping. The position of each tie rod end must be maintained as the clamps are tightened to ensure free movement of each joint. Return the rod assembly to midposition of its travel. This should result in the inner and outer ball studs being retained in a parallel relationship with the intermediate (relay) rod and steering knuckle (arm) respectively. The following procedure should be used when installing tie rods.

1. If the tie rod ends were removed, lubricate the tie rod threads with EP Chassis lube and install ends on tie rod making sure both ends are threaded an equal distance from the tie rod.
2. Make sure that threads on ball studs and in ball stud nuts are perfectly clean and smooth. Check condition of ball stud seals; replace if necessary.

**NOTE:** Tool J-24434 may be used to install ball stud seals.

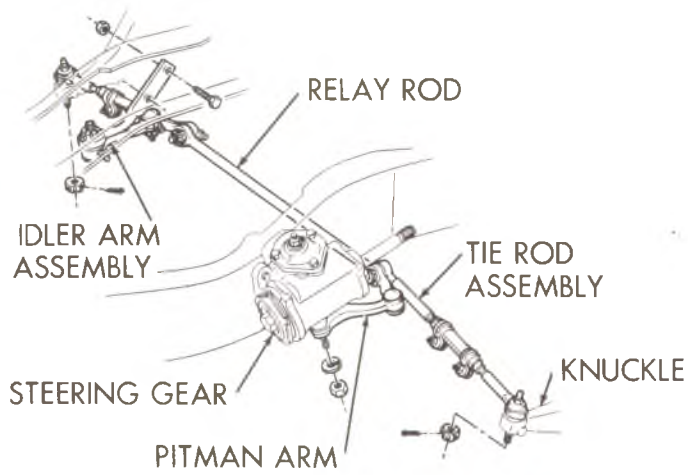

**C-SERIES**

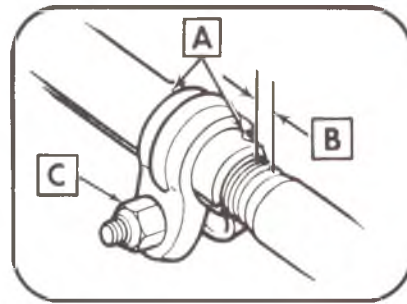

- A** **CAUTION** All clamps must be between & clear of dimples before torquing nut.
- B** Exposed socket thread length must be equal within  $\pm 0.06$  at each end of adjusting sleeve on L.H. & R.H. tie rod asm.
- C** All bolts must be installed in directions shown - Figs. 104 and 104B

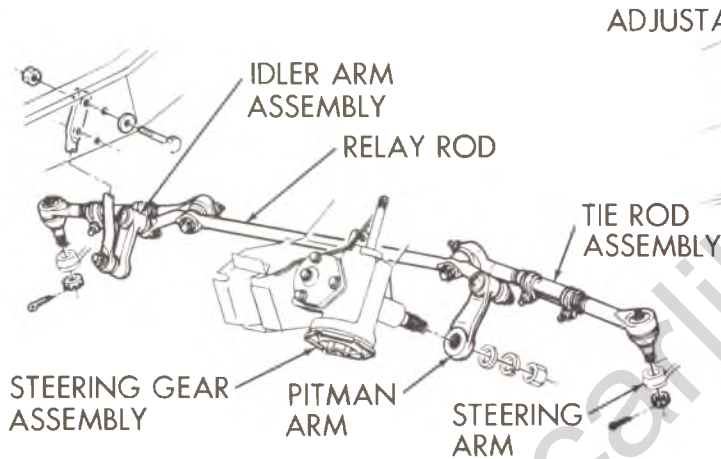

**VANS**

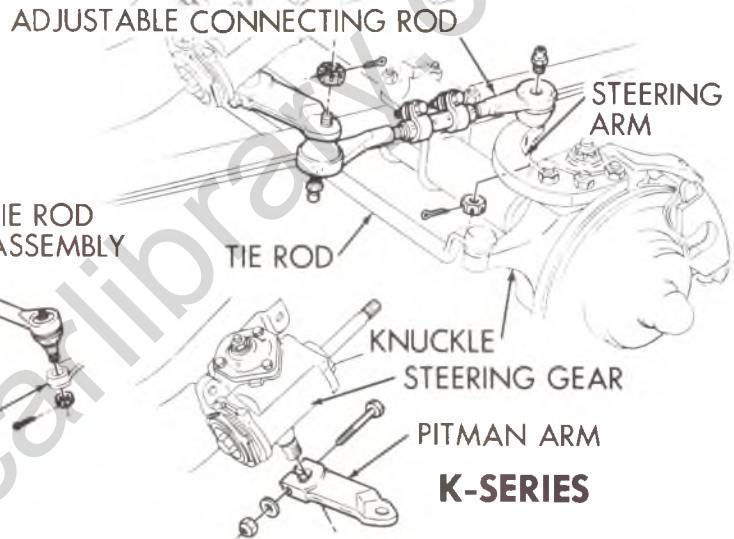

**K-SERIES**

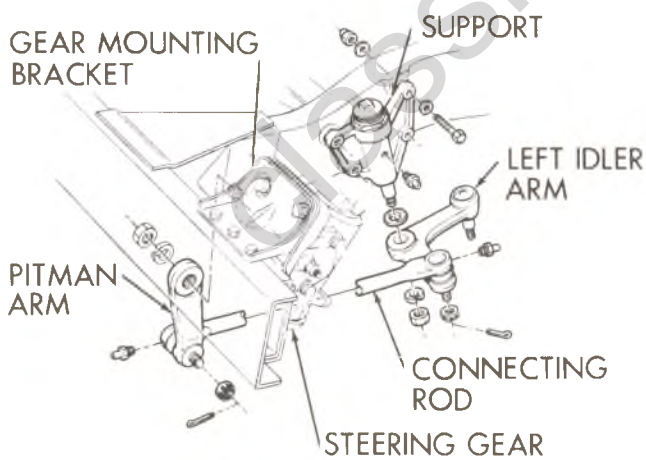

**MOTOR HOME**

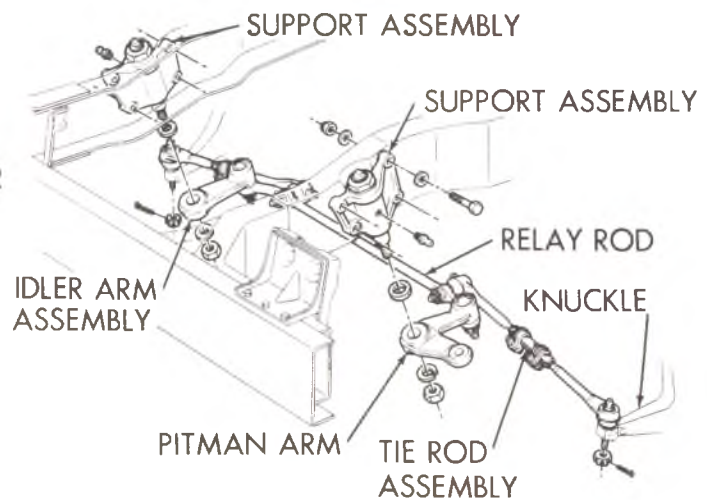

**MOTOR HOME**

Fig. 102—Steering Linkage

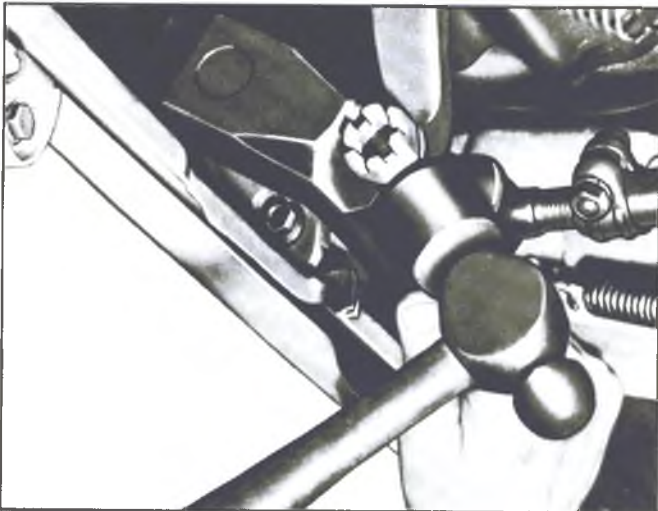

Fig. 103—Ball Stud Removal - Typical

NOTE: If threads are not clean and smooth, ball studs may turn in tie rod ends when attempting to tighten nut.

3. Install ball studs in steering arms and relay rod.
4. Install ball stud nut, tighten to specifications and install new cotter pins; see Specifications Section at rear of manual. Lubricate tie rod ends.

NOTE: Never back off nut to align the cotter pin, always tighten nut to next slot that lines up with hole in stud.

5. Adjust toe-in as described in Section 3.

**CAUTION:** Before tightening the tie rod adjusting sleeve clamp bolts, be sure that the following conditions have been met:

- a. The sleeve clamps must be positioned between the locating dimples at either end of the sleeve.
- b. The clamps must be positioned within the angular travel indicated in Figure 104.
- c. The relationship of the clamp slot with the slit in the sleeve should be maintained as shown in Figure 104.
- d. Rotate both inner and outer tie rod housing rearward to the limit of ball joint travel before tightening clamps. Tighten clamps to specifications. Return tie rod assembly to the center of travel.
- e. All procedures for alignment, adjustment and assembly of tie rods applies to each side.
- f. Check each assembly to be sure that a total travel of at least 35° can be obtained using a bubble protractor and a pair of vise grips (Fig. 104A).

**Inspection**

To ensure proper installation, it is necessary to perform the following inspection after any change of toe setting or removal of any ball stud:

1. Check the total rotation of the tie rod assembly

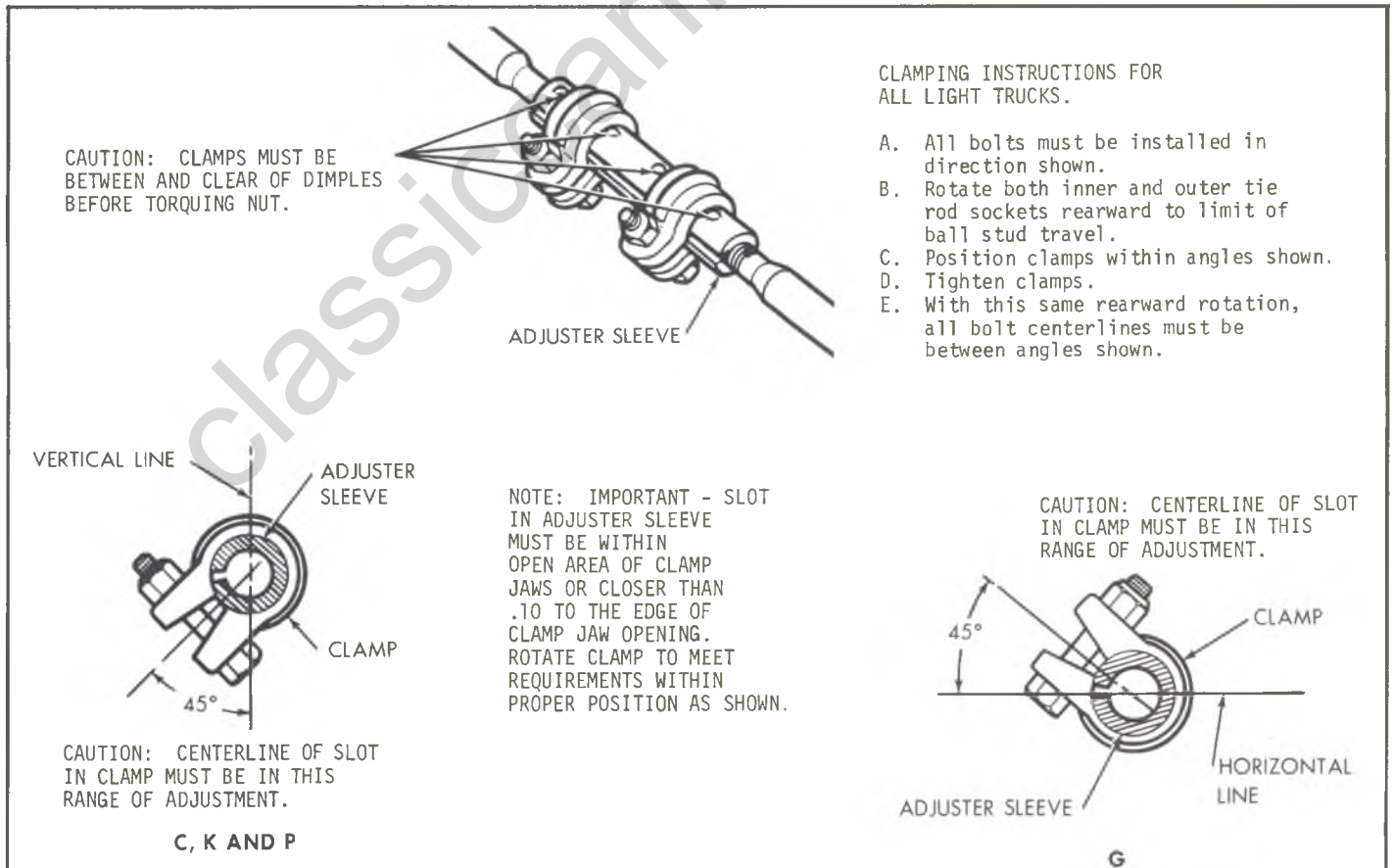

Fig. 104—Tie Rod Clamp Relationships

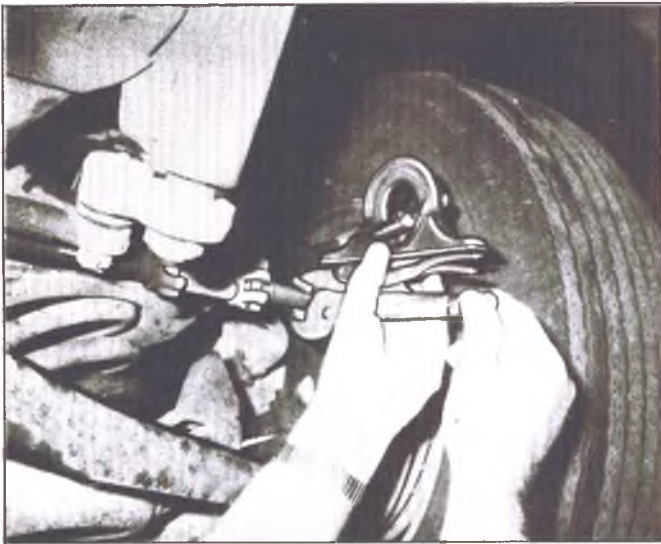

Fig. 104A—Tie Rod Inspection

using the following procedure:

- a. Lubricate inner and outer tie rod ends.
- b. Attach vise grip pliers to the outer tie rod end.
- c. Rotate outer tie rod end counterclockwise (up) to maximum position. Attach bevel protractor as shown in Figure 104A. Center protractor bubble indicator and record reading.

- d. Rotate tie rod end clockwise (down) to maximum position. Center protractor bubble indicator and record reading.
- e. Compare protractor readings obtained in Steps c and d. Total rotation of tie rod assembly should measure at least 35°.
- f. If rotation is less than 35°, loosen one tie rod sleeve clamp and rotate both tie rod ends to their maximum limit **both ends must be rotated in the same direction**
- g. Tighten tie rod clamp and again rotate both ends to their maximum limits, repeating Steps c and d. This recheck of total rotation will result in a minimum of 35° travel.
- h. After obtaining the correct amount of rotation (35° or greater), position the outer tie rod end approximately midway in this travel.

If rotating checks, outlined above, reveal a rough or lumpy feel, the inner or outer tie rod end assembly may have excessive wear and should be replaced.

If all of the above mentioned conditions are met, proper tie rod installation is assured.

### Relay Rod Removal

1. Raise vehicle on hoist.

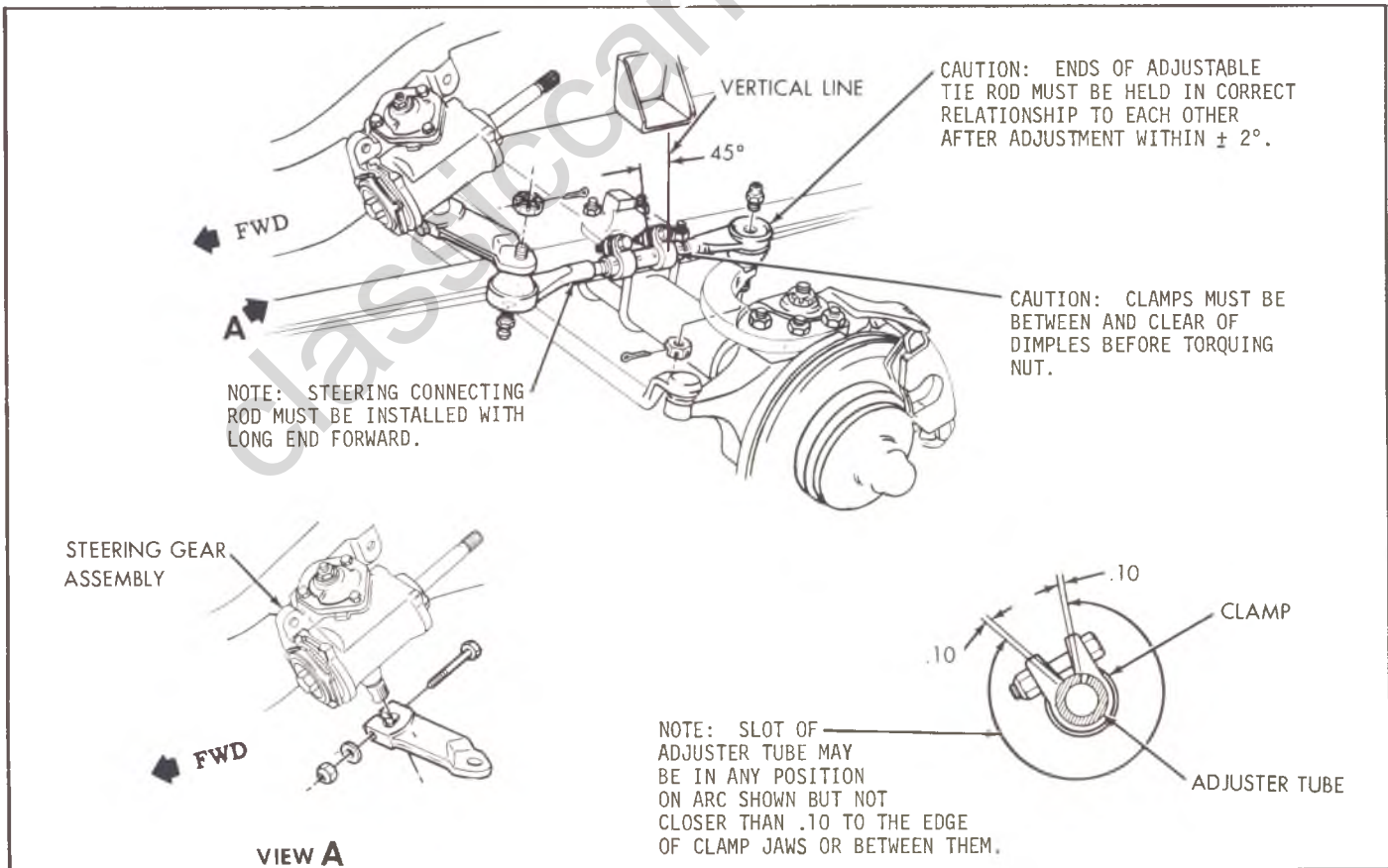

Fig. 104B—Adjustable Connecting Rod Assembly K Series

2. Remove inner ends of the tie rods from relay rod as described under "Tie Rod—Removal".
3. Remove the cotter pins from the pitman and idler arm ball studs at the relay rod. Remove the castellated nuts.
4. Remove the relay rod from the pitman and idler arms by tapping on the relay rod ball stud bosses with a hammer, while using a heavy hammer as a backing (fig. 103).
5. Remove the relay rod from the vehicle.

#### Installation

**CAUTION:** See the *CAUTION* on page 1 of this section regarding the fasteners referred to in steps 2 and 3.

1. Make sure that threads on the ball studs and in the ball stud nuts are perfectly clean and smooth. Check condition of ball stud seals; replace if necessary.

**NOTE:** If threads are not clean and smooth, ball studs may turn in sockets when attempting to tighten nut.

2. Install the relay rod to the idler arm and pitman arm ball studs, making certain the seals are in place. Install and torque the nut to specifications and then install the cotter pin.

**NOTE:** Never back off the nut to align cotter pin, always tighten nut to next slot that lines up with hole in stud.

3. Install the tie rods to the relay rod as previously described under "Tie Rod—Installation". Lubricate the tie rod ends.
4. Lower the vehicle to the floor.
5. Adjust toe-in (see Section 3) and align steering wheel as described previously in this section under "Steering Wheel Alignment and High Point Centering".

#### Idler Arm

**NOTE:** The idler arm assembly should always be replaced if it is found that an up and down force of 25 pounds, applied at the relay rod end of the idler arm, produces a vertical lash of more than 1/8" in the straight ahead position.

#### Removal

1. Raise vehicle on a hoist.
2. Remove the cotter pin and castellated nut from ball stud at the relay rod. Remove the ball stud from the relay rod by tapping on the relay rod boss with a hammer, while using a heavy hammer as a backing (fig. 103).
3. Remove the idler arm to frame bolt and remove the idler arm assembly.

#### Installation

**CAUTION:** See the *CAUTION* on page 1 of this section regarding the fasteners referred to in steps 1 and 3.

1. Position the idler arm on the frame and install the mounting bolts (special plain washers under bolt heads); torque the nuts to specifications.
2. Make sure that the threads on the ball stud and in the ball stud nut are perfectly clean and smooth. Check condition of ball stud seal; replace if necessary.

**NOTE:** If threads are not clean and smooth, ball stud may turn in the socket when attempting to tighten nut.

3. Install the idler arm ball stud in the relay rod, making certain the seal is positioned properly; install the nut and torque to specifications.

**NOTE:** Never back off nut to align cotter pin, always tighten nut to the next slot that lines up with the hole in the stud.

4. Install cotter pin.
5. Lower the vehicle to the floor.

#### Pitman Arm

##### Removal

1. Raise vehicle on hoist.
2. Remove cotter pin from pitman arm ball stud and remove nut.
3. Remove pitman arm or relay rod from ball stud by tapping on side of rod or arm (in which the stud mounts) with a hammer while using a heavy hammer or similar tool as a backing (fig. 103). Pull on linkage to remove from stud.
4. Remove pitman arm nut from pitman shaft or clamp bolt from pitman arm, and mark relation of arm position to shaft.
5. Remove pitman arm, using Tool J-6632 or J-5504 (Fig. 48).

##### Installation

**CAUTION:** See the *CAUTION* on page 1 of this section regarding the fasteners referred to in steps 3 and 4.

1. Install pitman arm on pitman shaft, lining up the marks made upon removal.

**CAUTION:** If a clamp type pitman arm is used, spread the pitman arm just enough, with a wedge, to slip arm onto pitman shaft. Do not spread pitman arm more than required to slip over pitman shaft with hand pressure. Do not hammer or damage to steering gear may result. Be sure to install the hardened steel washer before installing the nut.

2. Make sure that threads on ball studs and in ball stud nuts are clean and smooth. Check condition of



ball stud seals; replace if necessary.

NOTE: If threads are not clean and smooth, ball studs may turn in sockets when attempting to tighten nut.

3. Install pitman shaft nut or pitman arm clamp bolt and torque to specifications.
4. Position ball stud onto pitman arm or relay rod. Install nut and torque to specifications.
5. Install cotter pin.

NOTE: Never back off nut to align cotter pin, always tighten nut to next slot that lines up with hole in stud.

6. Lubricate ball studs.
7. Lower the vehicle to the floor.

### Steering Connecting Rod

#### Removal

1. Remove cotter pins from ball studs and remove castellated nuts.
2. Remove ball studs from steering arm and pitman arm boss with a heavy hammer and striking other side of boss with lighter hammer (similar to method shown in figure. 103).

#### Installation

CAUTION: See the CAUTION on page 1 of this section regarding the fasteners referred to in step 3.

For procedure concerning adjustment of connecting rod and steering wheel and gear high point centering see page 25.

1. Make sure that threads on ball studs and in ball stud nuts are clean and smooth. Check condition of ball stud seals - replace if necessary.

NOTE: If threads are not clean and smooth, ball studs may turn in connecting rod when attempting to tighten nut.

2. Install ball studs in steering arm and pitman arm. Be sure to install the long end of the connecting rod assembly to the pitman arm.
3. Install ball stud nuts and torque to specifications.

NOTE: Never back off nut to align cotter pin, always tighten nut to next slot that lines up with hole in stud.

4. Install cotter pins and lubricate ball studs.

NOTE: For proper alignment and orientation of connecting rod clamps see figure 104B.

### POWER STEERING SYSTEM

#### Power Steering Gear

##### Removal

1. Disconnect hoses at gear. When hoses are

disconnected, secure ends in raised position to prevent drainage of oil. Cap or tape the ends of the hoses to prevent entrance of dirt.

2. Install two plugs in gear fittings to prevent entrance of dirt.
3. Remove the flexible coupling to steering shaft flange bolts (G, C and K models) or the lower universal joint pinch bolt (P models). Mark the relationship of the universal yoke to the stub shaft.
4. Mark the relationship of the pitman arm to the pitman shaft. Remove the pitman shaft nut or pitman arm pinch bolt and then remove the pitman arm from the pitman shaft using Puller J-6632 (fig. 48).
5. Remove the steering gear to frame bolts and remove the gear assembly.
6. G, C and K Models – Remove the flexible coupling pinch bolt and remove the coupling from the steering gear stub shaft.

#### Installation

CAUTION: See CAUTION on page 1 of this section regarding the fasteners referred to in steps 1, 3, 4 and 5.

1. Install the flexible coupling onto the steering gear stub shaft, aligning the flat in the coupling with the flat on the shaft. Push the coupling onto the shaft until the stub shaft bottoms on the coupling reinforcement. Install the pinch bolt and torque to specifications.

NOTE: The coupling bolt must pass through the shaft undercut.

2. Place the steering gear in position, guiding the coupling bolt into the steering shaft flange.
3. Install the steering gear to frame bolts and torque to specifications.
4. If flexible coupling alignment pin plastic spacers

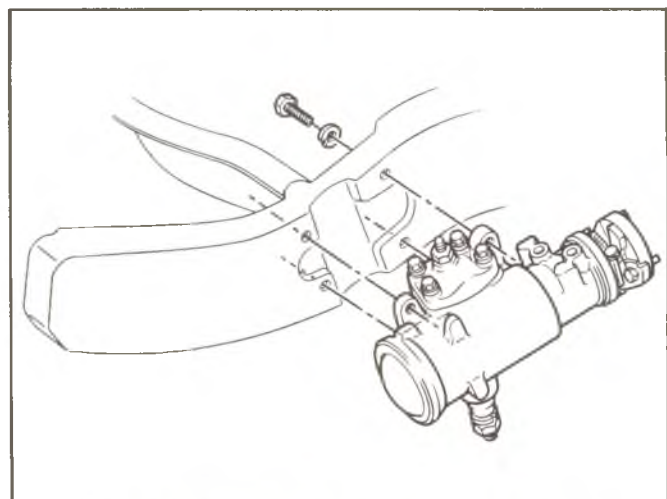

Fig. 105—Power Steering Gear Mounting-Typical

were used, make sure they are bottomed on the pins, tighten the flange bolt nuts to specifications and then remove the plastic spacers.

5. If flexible coupling alignment pin plastic spacers were not used, center the pins in the slots in the steering shaft flange and then install and torque the flange bolt nuts to specifications.

#### **P Models**

- a. Place the steering gear in position, guiding the stub shaft into the universal joint assembly and lining up the marks made at removal.

NOTE: If a new gear was installed, line up the mark on the stub shaft with the mark on the universal yoke.

- b. Install the steering gear to frame bolts and torque to specifications.
- c. Install the universal joint pinch bolt and torque to specification.

NOTE: The pinch bolt must pass through the shaft undercut.

#### **All Models**

6. Install the pitman arm onto the pitman shaft, lining up the marks made at removal. Install the pitman shaft nut or pitman arm pinch bolt and torque to specifications.
7. Remove the plugs and caps from the steering gear and hoses and connect the hoses to the gear. Tighten the hose fittings to specified torque.

## **POWER STEERING PUMP**

### **Removal (Fig. 106)**

1. Disconnect hoses at pump. When hoses are disconnected, secure ends in raised position to prevent drainage of oil. Cap or tape the ends of the hoses to prevent entrance of dirt.

On Models with remote reservoir Engine — Disconnect reservoir hose at pump and secure in raised position. Cap hose pump fittings.

2. Install two caps at pump fittings to prevent drainage of oil from pump.
3. Loosen bracket-to-pump mounting nuts.
4. Remove pump belt.
5. Remove bracket-to-pump bolts and remove pump from vehicle.

6. Remove drive pulley attaching nut.
7. Remove pulley from shaft. Do not hammer pulley off shaft as this will damage pump. Use Tool J-21239-1 for pulling stamped pulleys or Tool J-8433-1 with Adapter J-8433-2 for cast pulleys.

### **Installation**

1. Install pump pulley.

**CAUTION:** Do not hammer on pump shaft. Use pulley nut to pull pulley onto shaft. Use a new nut.

NOTE: On models equipped with a remote power steering pump reservoir fill the pump housing with as much fluid as possible before mounting.

2. Position pump assembly on vehicle and install attaching parts loosely.
3. Connect and tighten hose fittings.
4. Fill reservoir. Bleed pump by turning pulley backward (counter-clockwise as viewed from front) until air bubbles cease to appear.
5. Install pump belt over pulley.
6. Tension belt as outlined under "Pump Belt Tension—Adjustment" in this section.
7. Bleed as outlined under "Maintenance and Adjustments."

## **POWER STEERING HOSES**

When servicing power steering hoses, avoid twisting the hoses unnecessarily.

Note and correct any hose contact with other parts of the vehicle that could cause chafing or wear.

Any maintenance operation, on the power steering equipment, should include a thorough inspection of the hydraulic line system.

**CAUTION:** If the power steering return hose is removed or replaced for any reason or shows leakage at either connection replace the existing "crimped" clamp with a "worm drive" clamp for proper sealing.

Figures 107A, 107B, 107C illustrate typical installations.

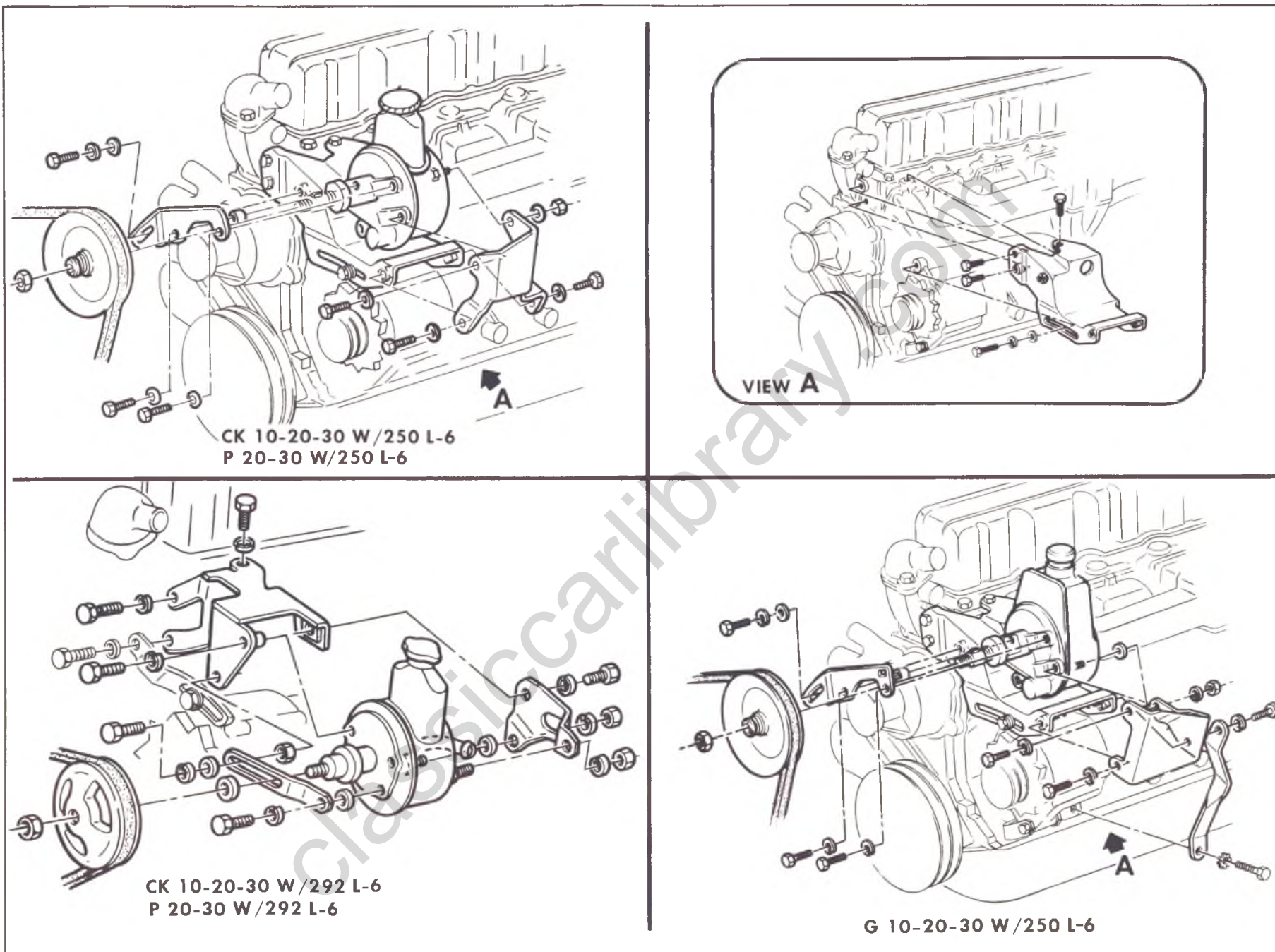

Fig. 106A—Power Steering Pump Mounting L-6—Typical

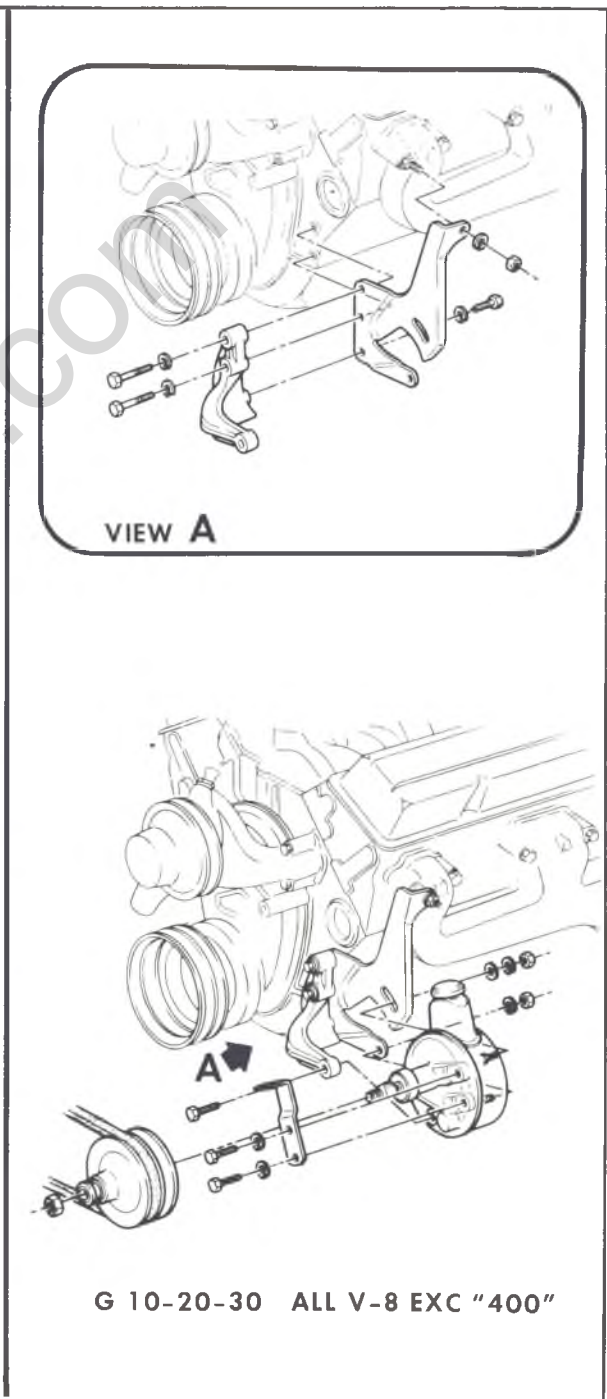
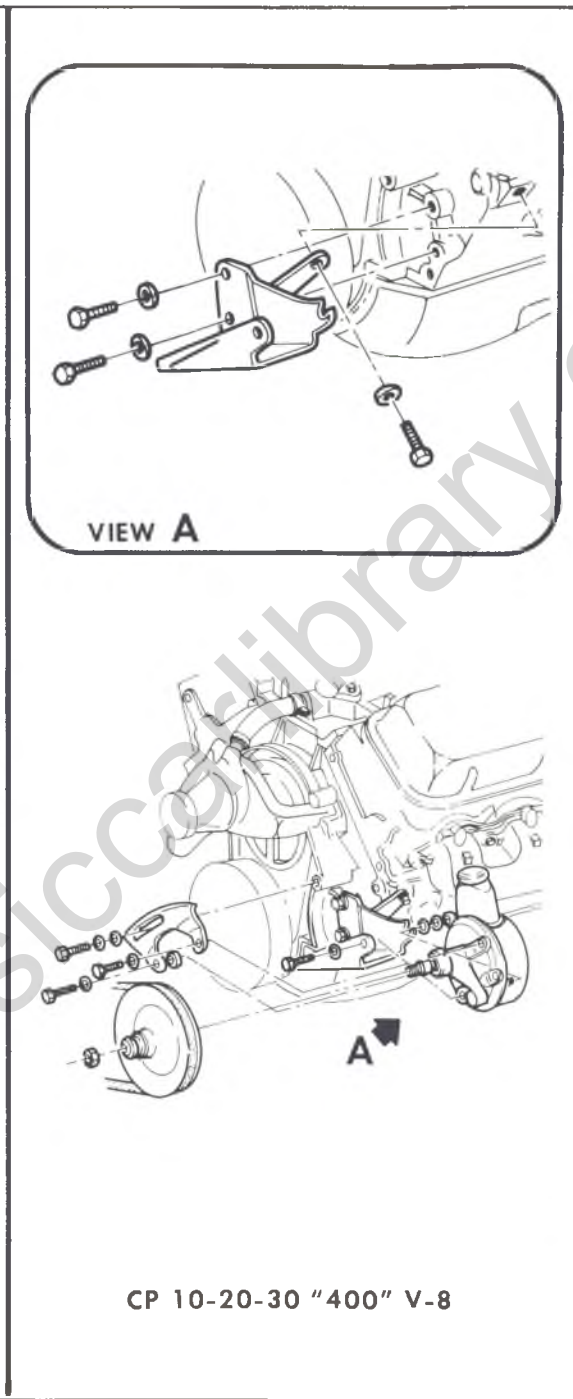
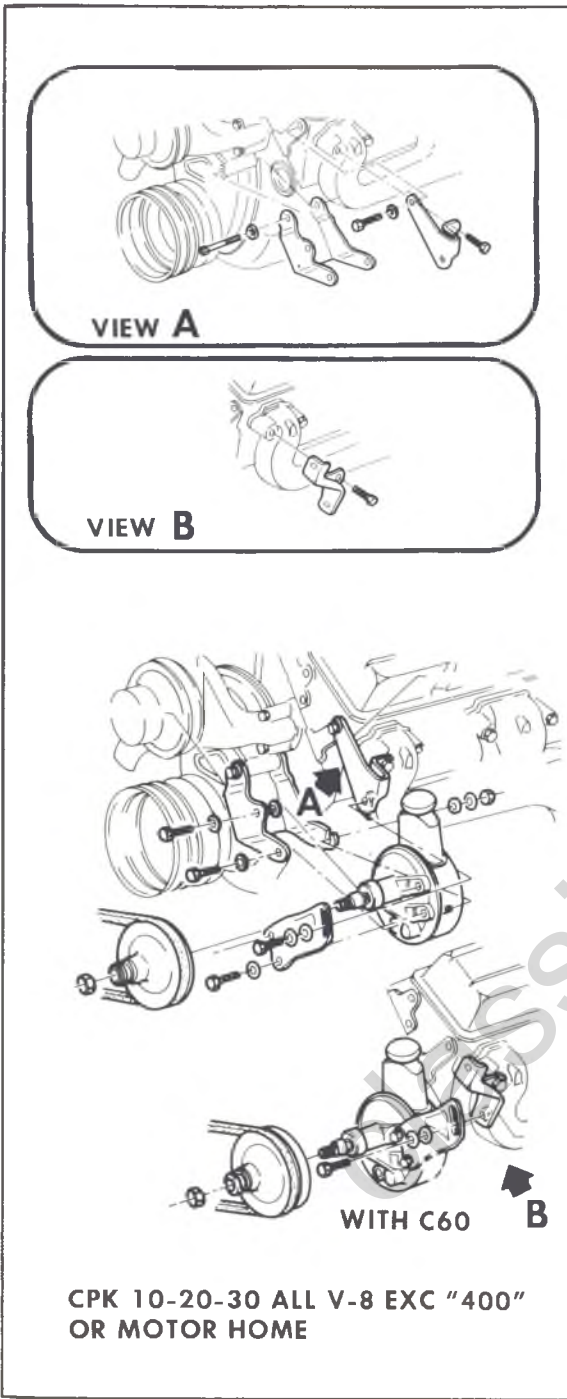
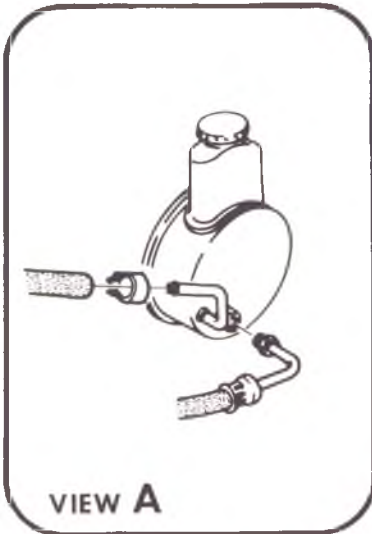
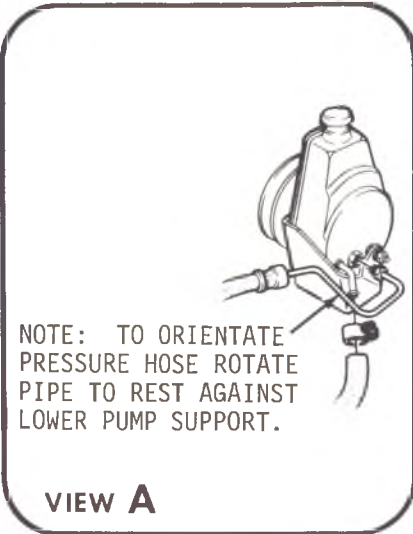

Fig. 106B—Power Steering Pump Mounting V-8—Typical



VIEW A



VIEW A

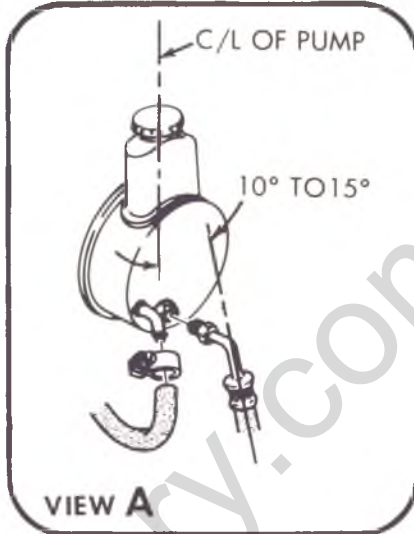

VIEW A

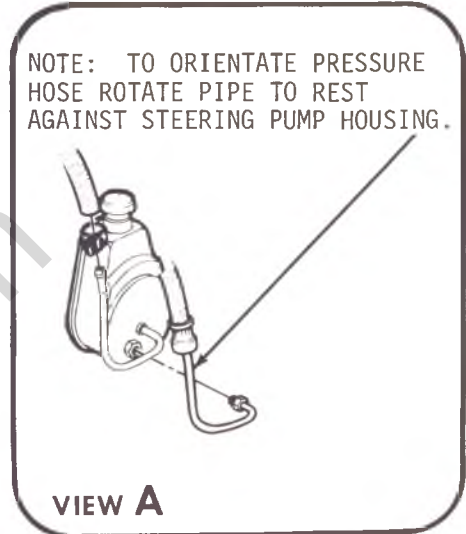

VIEW A

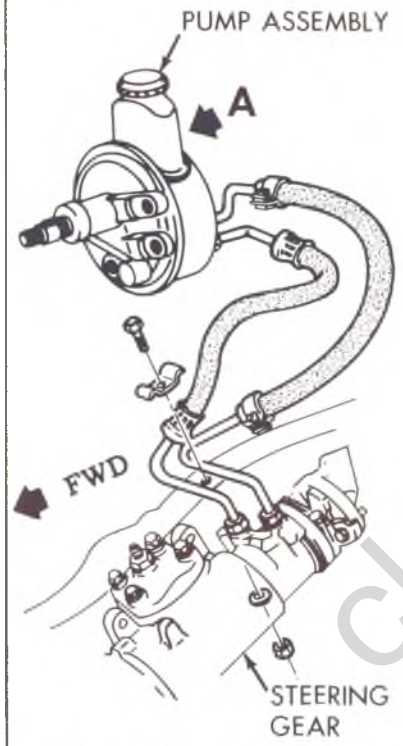

CK 10-20-30 L-6  
P 20-30 L-6

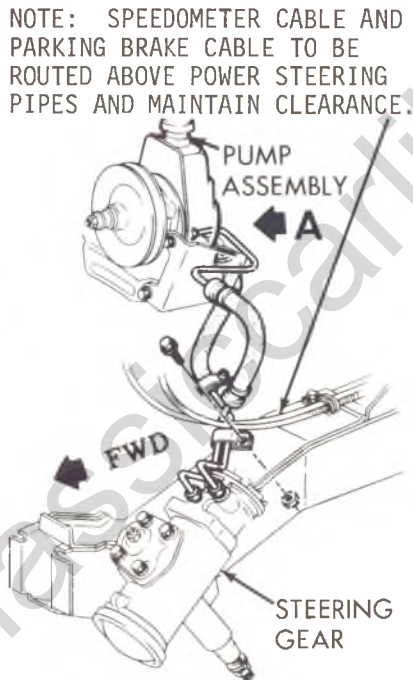

G 10-20-30 L-6

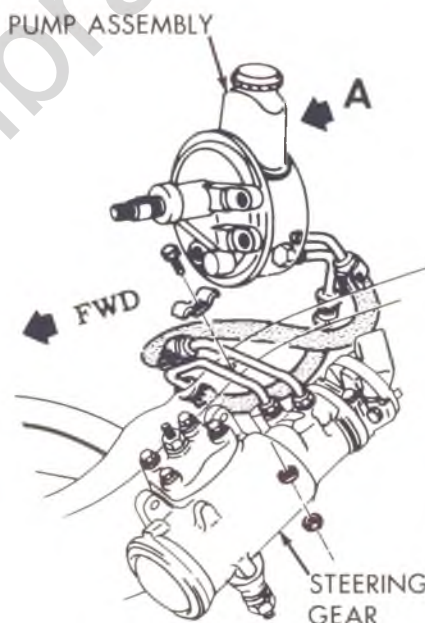

CK 10-20-30 V-8  
P 20-30 V-8

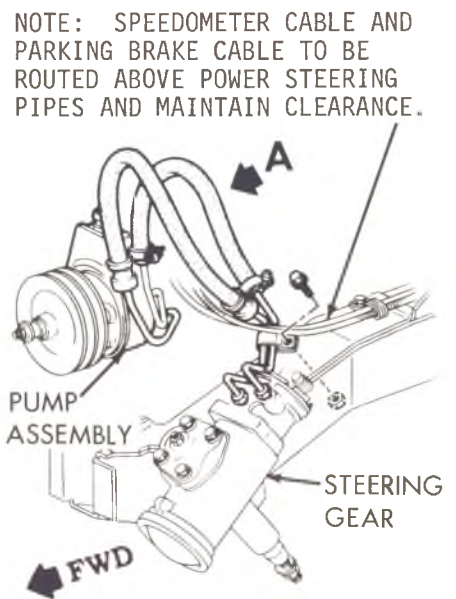

G 10-20-30 V-8

Fig. 107A—Power Steering Hose Routing—Typical

Fig. 107B—Power Steering Hose Routing With Hydroboost

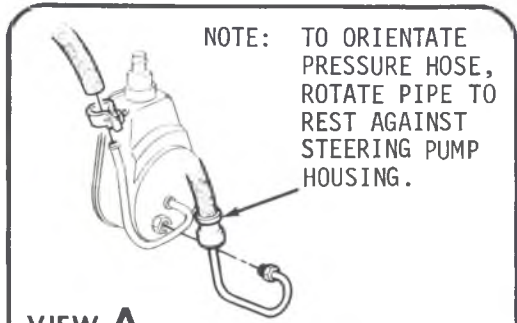

VIEW A

VIEW B

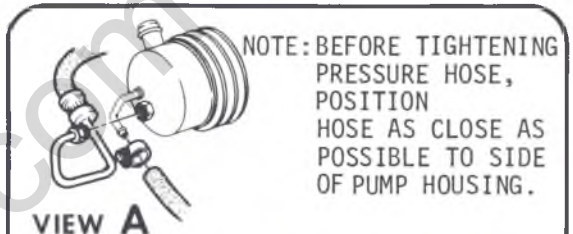
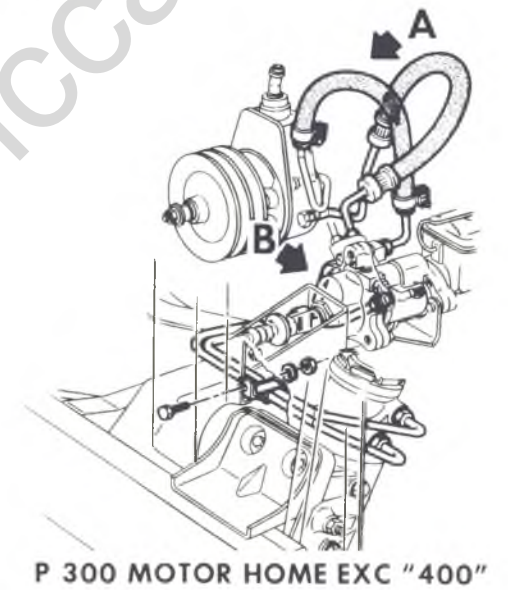
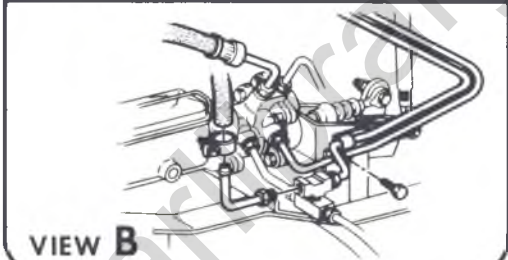
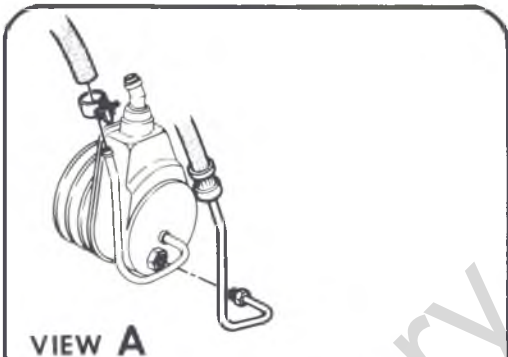
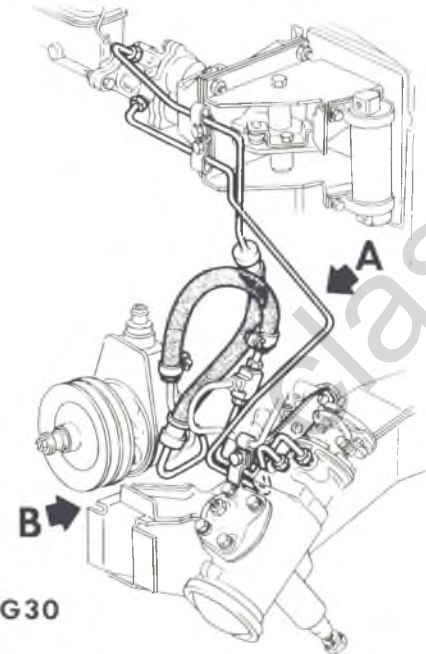

VIEW A

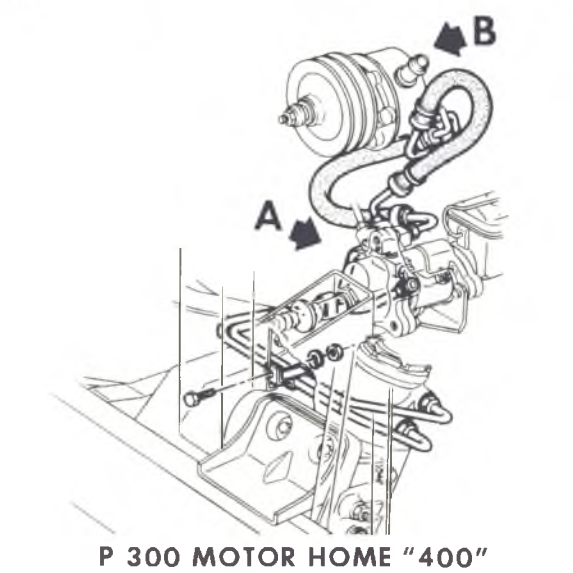
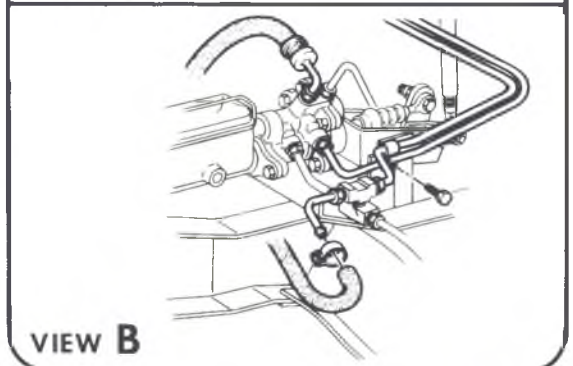

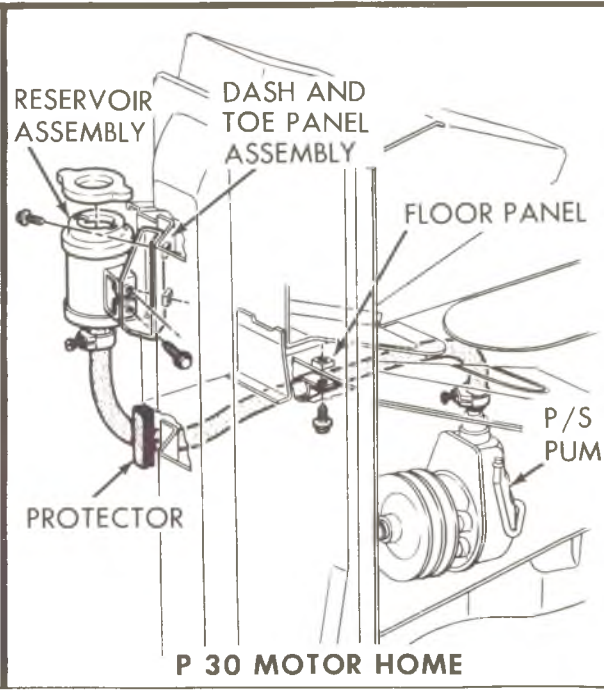
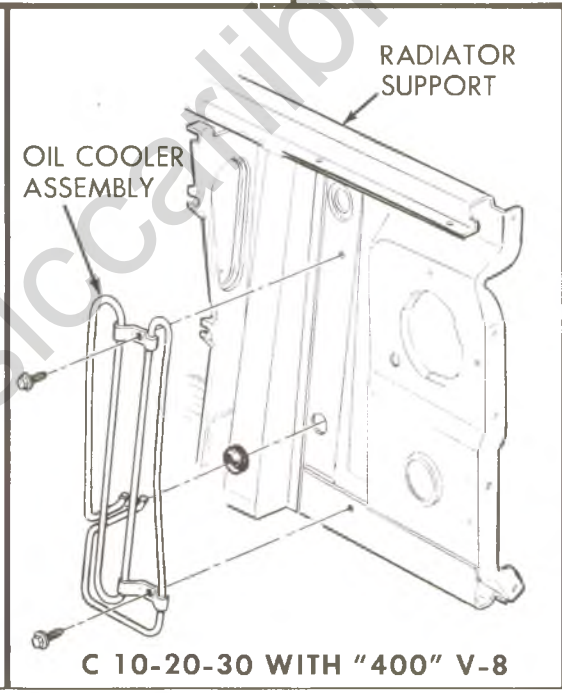
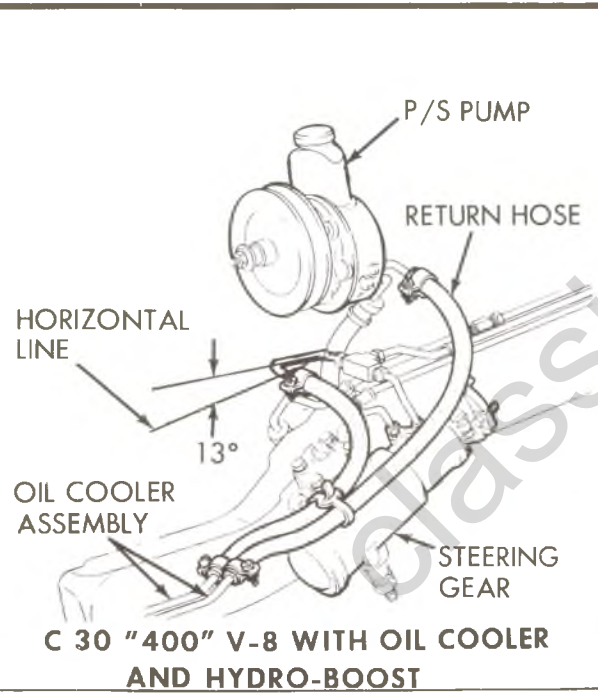
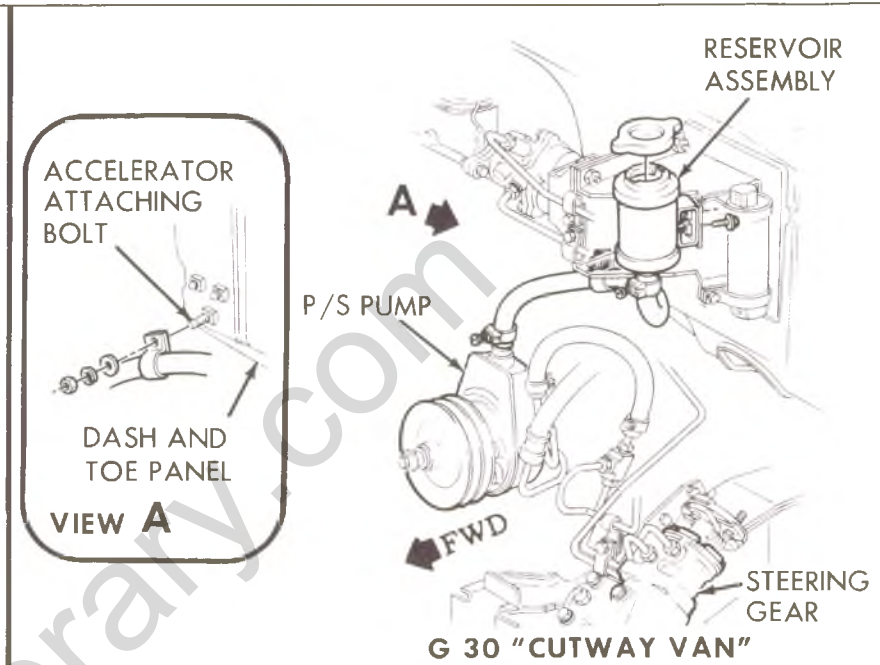
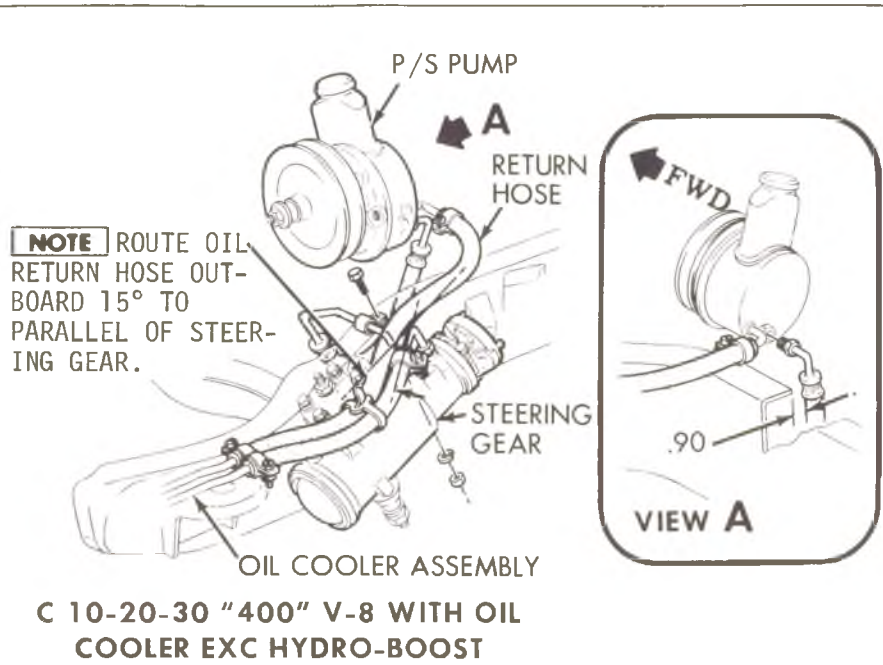

Fig. 107C—Power Steering Hoses and Piping

## STEERING SYSTEM DIAGNOSIS

CONDITION	POSSIBLE CAUSE	CORRECTION
<p>Excessive Play or Looseness in Steering System.</p>	<p>Front wheel bearings loosely adjusted.</p> <p>Worn steering shaft couplings.</p> <p>Worn upper ball joints.</p> <p>Steering wheel loose on shaft, loose pitman arm, tie rods, steering arms or steering linkage ball studs.</p> <p>Steering gear thrust bearings loosely adjusted.</p> <p>Excessive over-center lash in steering gear.</p> <p>Worn intermediate rod or tie rod sockets.</p>	<p>Adjust bearings to obtain proper end play.</p> <p>Replace part.</p> <p>Check and replace if necessary.</p> <p>Tighten to specified torque, or replace if necessary.</p> <p>Adjust preload to specification.</p> <p>Adjust preload to specification.</p> <p>Replace worn part.</p>
<p>Excessive looseness in tie rod or intermediate rod pivots, or excessive vertical lash in idler support.</p>	<p>Seal damage and leakage resulting in loss of lubricant, corrosion and excessive wear.</p>	<p>Replace damaged parts as necessary. Properly position upon reassembly.</p>

Fig. 108A—Steering Linkage Diagnosis



CONDITION	POSSIBLE CAUSE	CORRECTION
<p>Hard Steering – Excessive Effort Required at Steering Wheel.</p>	<p>Low or uneven tire pressure.</p> <p>Steering linkage or bolt joints need lubrication.</p> <p>Tight or frozen intermediate rod, tie rod or idler socket.</p> <p>Steering gear to column misalignment.</p> <p>Steering gear adjusted too tightly.</p> <p>Front wheel alignment incorrect. (manual gear)</p>	<p>Inflate to specified pressures.</p> <p>Lube with specified lubricant.</p> <p>Lube replace or reposition as necessary.</p> <p>Align column.</p> <p>Adjust over-center and thrust bearing preload to specification.</p> <p>Check alignment and correct as necessary.</p>
<p>Poor Returnability.</p>	<p>Steering linkage or ball joints need lubrication.</p> <p>Steering gear adjusted too tightly.</p> <p>Steering gear to column misalignment.</p> <p>Front wheel alignment incorrect. (Caster)</p>	<p>Lube with specified lubricant.</p> <p>Adjust over-center and thrust bearing preload to specifications.</p> <p>Align column.</p> <p>Check alignment and correct as necessary.</p>

Fig. 108B—Steering Linkage Diagnosis

CONDITION	POSSIBLE CAUSE	CORRECTION
Rattle or Chuck in Steering Gear.	<p>Insufficient or improper lubricant in steering gear.</p> <p>Pitman arm loose on shaft or steering gear mounting bolt loose.</p> <p>Loose or worn steering shaft bearing.</p> <p>Excessive over-center lash or worm thrust bearings adjusted too loose.</p> <p>NOTE: On turns a slight rattle may occur, due to the increased lash between ball nut and pitman shaft as gear moves off the center of "high point" position. This is normal and lash must not be reduced to eliminate this slight rattle.</p>	<p>Add lube specified.</p> <p>Tighten to specified torque.</p> <p>Replace steering shaft bearing.</p> <p>Adjust steering gear to specified preloads.</p>
Poor Returnability	<p>Steering column misaligned.</p> <p>Insufficient or improper lubricant in steering gear or front suspension.</p> <p>Steering gear adjusted too tight.</p> <p>Front wheel alignment incorrect (Caster)</p>	<p>Align column.</p> <p>Lubricate as specified.</p> <p>Adjust over-center and thrust bearing preload to specifications.</p> <p>Adjust to specifications.</p>

Fig. 109A—Manual Gear Diagnosis

9-74 STEERING

CONDITION	POSSIBLE CAUSE	CORRECTION
<p>Excessive Play or Looseness in Steering System.</p>	<p>Front wheel bearings loosely adjusted.</p> <p>Worn upper ball joints.</p> <p>Steering wheel loose on shaft, loose pitman arm, tie rods, steering arms or steering linkage ball nuts.</p> <p>Excessive over-center lash.</p> <p>Worm thrust bearings loosely adjusted.</p>	<p>Adjust to obtain proper end play.</p> <p>Check and replace ball joints if necessary.</p> <p>Tighten to specification, replace if worn or damaged.</p> <p>Adjust over-center preload to specifications.</p> <p>Adjust worm thrust bearing preload to specifications.</p>
<p>Hard Steering — Excessive Effort Required at Steering Wheel</p>	<p>Low or uneven tire pressure.</p> <p>Insufficient or improper lubricant in steering gear or front suspension.</p> <p>Steering shaft flexible coupling misaligned.</p> <p>Steering gear adjusted too tight.</p> <p>Front wheel alignment incorrect. (Manual Gear)</p>	<p>Inflate to specified pressures.</p> <p>Lubricate as specified. Re-lubricate at specified intervals.</p> <p>Align column and coupling.</p> <p>Adjust over-center and thrust bearing preload to specifications.</p> <p>Adjust to specifications.</p>

Fig. 109B—Manual Gear Diagnosis

## DIAGNOSIS C AND K STEERING COLUMNS

This section contains diagnostic information to help locate the cause of the problem in the column. Reference should be made to the correct method of column disassembly, repair, adjustment and reassembly. Damaged, broken or deformed parts must be replaced with the correct replacement.

### GENERAL INFORMATION

All C and K models are equipped with function locking energy absorbing Steering Columns. The columns are of five basic designs as follows:

1. **Synchromesh** — The synchromesh column is used on models with the standard transmission and column mounted shift levers. The shift tube, within the outer column jacket, includes two lower shift levers for connection to the transmission control linkage.
2. **Floor Shift** — This column is used on models equipped with a manual transmission with the shift lever on the floor. This column does not incorporate a shift tube.
3. **AUTOMATIC TRANSMISSION**—Available with column shift only Locks the transmission and steering wheel while in park position and the lock cylinder is in "Lock" position.
4. **TILT WHEEL OPTION** — The upper end and steering shaft of this column is specifically designed to accommodate the optional tilt steering wheel. It is available with either manual (the fourth column type) or automatic transmission on (the fifth column type).

To perform diagnostic procedures on the steering column upper end components, it is not necessary to remove the column from the vehicle.

The steering wheel, horn components, directional signal switch, ignition switch and lock cylinder may be removed with the column remaining in the vehicle as described in the Service Manual under "Component Part Replacement".

**CAUTION:** *The outer mast jacket shift tube, steering shaft and instrument panel mounting bracket are designed as energy absorbing units. Because of the design of these components, it is absolutely necessary to handle the column with care when performing any service operation. Avoid hammering, jarring, dropping or leaning on any portion of the column. When reassembling the column components, use only the specified screws, nuts and bolts and tighten to specified torque. Care should be exercised not to use over-length screws or bolts as they may prevent a portion of the column from compressing under impact.*

### COLLISION DIAGNOSIS

To determine if the energy absorbing steering column components are functioning as designed, or if repairs are required, a close inspection should be made. An inspection is called for in all cases where damage is evident or whenever the vehicle is being repaired due to a front end collision. Whenever a force has been exerted on the steering wheel or steering column, or its components, inspection should also be made. If damage is evident, the affected parts must be replaced.

The inspection procedure for the various steering column components on C and K trucks is as follows:

### COLUMN SUPPORT BRACKET

Damage in this area will be indicated by separation of the mounting capsules from the bracket. The bracket will have moved forward toward the engine compartment and will usually result in collapsing of the jacket section of the steering column.

### COLUMN JACKET

Inspect jacket section of column for looseness, and/or bends.

### SHIFTER SHAFT

Separation of the shifter shaft sections will be internal and cannot be visually identified. Hold lower end of the "shifter shaft" and move "shift lever" on column through its ranges and up and down. If there is little or no movement of the "shifter shaft", the plastic joints are sheared.

### Steering Shaft

If the steering shaft plastic pins have been sheared, the shaft will rattle when struck lightly from the side and some lash may be felt when rotating the steering wheel while holding the rag joint. It should be noted that if the steering shaft pins are sheared due to minor collision with no appreciable damage to other components, that the vehicle can be safely steered; however, steering shaft replacement is recommended.

Because of the differences in the steering column types, be sure to refer to the set of instructions below which apply to the column being serviced.

### Method To Determine Column Collapse

Measure distance between top of neutral-start switch window opening and the bottom of the upper jacket. The correct value is shown below:

- a. C-Truck 5 11/16" to 5 1/2".
- b. K-Truck 5 11/16" to 5 1/2".

## 9-76 STEERING

### Instrument Panel Bracket Capsule Damage

**NOTE:** The bolt head must not contact surface "A". If contact is made, the capsule shear load will be increased. If this condition exists replace the bracket.

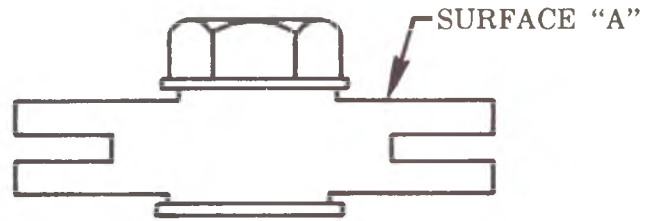

## AUTOMATIC TRANSMISSION COLUMNS

### LOCK SYSTEM – WILL NOT UNLOCK

Cause	Solution
A. Lock bolt damaged.	A. Replace lock bolt.
B. Defective lock cylinder.	B. Replace or repair lock cylinder.
C. Damaged housing.	C. Replace housing.
D. Damaged or collapsed sector.	D. Replace sector.
E. Damaged rack.	E. Replace rack.
F. Shear Flange on sector shaft collapsed.	F. Replace.

### LOCK SYSTEM – WILL NOT LOCK

Cause	Solution
A. Lock bolt spring broken or defective.	A. Replace spring.
B. Damaged sector tooth, or sector installed incorrectly.	B. Replace, or install correctly.
C. Defective lock cylinder.	C. Replace lock cylinder
D. Burr or lock bolt or housing.	D. Remove Burr.
E. Damaged housing.	E. Replace housing.
F. Transmission linkage adjustment incorrect.	F. Readjust (see Sec. 7).
G. Damaged rack.	G. Replace rack.
H. Interference between bowl and coupling (tilt).	H. Adjust or replace as necessary.
I. Ignition switch stuck.	I. Readjust or replace.
J. Actuator rod restricted or bent.	J. Readjust or replace.

### LOCK SYSTEM – HIGH EFFORT

Cause	Solution
A. Lock cylinder defective.	A. Replace lock cylinder.
B. Ignition switch defective.	B. Replace switch.
C. Rack preload spring broken or deformed.	C. Replace spring.
D. Burrs on sector, rack, housing, support, tang of shift gate or actuator rod coupling.	D. Remove Burr.
E. Bent sector shaft.	E. Replace shaft.
F. Distorted rack.	F. Replace rack
G. Misalignment of housing to cover (tilt only).	G. Replace either or both.

Fig. 110—Automatic Transmission Column Diagnosis

<b>LOCK SYSTEM – HIGH EFFORT (CONT'D.)</b>	
<b>Cause</b>	<b>Solution</b>
H. Distorted coupling slot in rack (tilt). I. Bent or restricted actuator rod. J. Ignition switch mounting bracket bent.	H. Replace rack. I. Straighten remove restriction or replace. J. Straighten or replace.
<b>HIGH EFFORT LOCK CYLINDER – BETWEEN “OFF” AND “OFF-LOCK” POSITIONS</b>	
<b>Cause</b>	<b>Solution</b>
A. Burr on tang of shift gate. B. Distorted rack.	A. Remove burr. B. Replace rack.
<b>STICKS IN “START” POSITION</b>	
<b>Cause</b>	<b>Solution</b>
A. Actuator rod deformed. B. Any high effort condition.	A. Straighten or replace. B. Check items under high effort section.
<b>KEY CAN NOT BE REMOVED IN “OFF-LOCK” POSITION</b>	
<b>Cause</b>	<b>Solution</b>
A. Ignition switch is not set correctly. B. Defective lock cylinder.	A. Readjust ignition switch. B. Replace lock cylinder.
<b>LOCK CYLINDER CAN BE REMOVED WITHOUT DEPRESSING RETAINER</b>	
<b>Cause</b>	<b>Solution</b>
A. Lock cylinder with defective retainer. B. Lock cylinder without retainer. C. Burr over retainer slot in housing cover.	A. Replace lock cylinder. B. Replace lock cylinder. C. Remove burr.
<b>LOCK BOLT HITS SHAFT LOCK IN “OFF” AND “PARK” POSITIONS</b>	
<b>Cause</b>	<b>Solution</b>
A. Ignition switch is not set correctly.	A. Readjust ignition switch.
<b>IGNITION SYSTEM – ELECTRICAL SYSTEM WILL NOT FUNCTION</b>	
<b>Cause</b>	<b>Solution</b>
A. Defective fuse in “accessory” circuit. B. Connector body loose or defective. C. Defective wiring.	A. Replace fuse. B. Tighten or replace. C. Repair or replace.

Fig. 111—Automatic Transmission Column Diagnosis

<b>IGNITION SYSTEM – ELECTRICAL SYSTEM – WILL NOT FUNCTION (CONT'D.)</b>	
<b>Cause</b>	<b>Solution</b>
D. Defective ignition switch. E. Ignition switch not adjusted properly.	D. Replace ignition switch. E. Readjust ignition switch.
<b>SWITCH WILL NOT ACTUATE MECHANICALLY</b>	
<b>Cause</b>	<b>Solution</b>
A. Defective ignition switch.	A. Replace ignition switch.
<b>SWITCH CAN NOT BE SET CORRECTLY</b>	
<b>Cause</b>	<b>Solution</b>
A. Switch actuator rod deformed. B. Sector to rack engaged in wrong tooth (tilt).	A. Repair or replace switch actuator rod. B. Engage sector to rack correctly.
<b>NOISE IN COLUMN</b>	
<b>Cause</b>	<b>Solution</b>
A. Coupling bolts loose. B. Column not correctly aligned. C. Coupling pulled apart. D. Sheared intermediate shaft plastic joint. E. Horn contact ring not lubricated. F. Lack of grease on bearings or bearing surfaces. G. Lower shaft bearing tight or frozen. H. Upper shaft tight or frozen. I. Shaft lock plate cover loose. J. Lock plate snap ring not seated. K. Defective buzzer dog cam on lock cylinder. L. One click when in "off-lock" position and the steering wheel is moved.	A. Tighten pinch bolts to specified torque. B. Realign column. C. Replace coupling and realign column. D. Replace or repair steering shaft and realign column. E. Lubricate with lubriplate. F. Lubricate bearings. G. Replace bearing. Check shaft and replace if scored. H. Replace housing assembly. I. Tighten three screws or, if missing, replace. CAUTION: Use specified screws. (15 in. lbs.) J. Replace snap ring. Check for proper seating in groove. K. Replace lock cylinder. L. Normal condition - lock bolt is seating.

Fig. 112—Automatic Transmission Column Diagnosis

<b>HIGH STEERING SHAFT EFFORT</b>	
<b>Cause</b>	<b>Solution</b>
<ul style="list-style-type: none"> <li>A. Column assembly misaligned in vehicle.</li> <li>B. Improperly installed or deformed dust seal.</li> <li>C. Tight or frozen upper or lower bearing.</li> <li>D. Flash on I.D. of shift tube from plastic joint.</li> </ul>	<ul style="list-style-type: none"> <li>A. Realign.</li> <li>B. Remove and replace.</li> <li>C. Replace affected bearing or bearings.</li> <li>D. Replace shift tube.</li> </ul>
<b>HIGH SHIFT EFFORT</b>	
<b>Cause</b>	<b>Solution</b>
<ul style="list-style-type: none"> <li>A. Column not aligned correctly in car.</li> <li>B. Improperly installed dust seal.</li> <li>C. Lack of grease on seal or bearing areas.</li> <li>D. Burr on upper or lower end of shift tube.</li> <li>E. Lower bowl bearing not assembled properly (tilt).</li> <li>F. Wave washer with burrs (tilt only).</li> </ul>	<ul style="list-style-type: none"> <li>A. Realign.</li> <li>B. Remove and replace.</li> <li>C. Lubricate bearings and seals.</li> <li>D. Remove burr.</li> <li>E. Reassemble properly.</li> <li>F. Replace wave washer.</li> </ul>
<b>IMPROPER TRANSMISSION SHIFTING</b>	
<b>Cause</b>	<b>Solution</b>
<ul style="list-style-type: none"> <li>A. Sheared shift tube joint.</li> <li>B. Improper transmission linkage adjustment.</li> <li>C. Loose lower shift lever.</li> <li>D. Improper gate plate.</li> <li>E. Sheared lower shift lever weld.</li> </ul>	<ul style="list-style-type: none"> <li>A. Replace shift tube assembly.</li> <li>B. Readjust linkage.</li> <li>C. Replace shift tube assembly.</li> <li>D. Replace with correct part.</li> <li>E. Replace tube assembly.</li> </ul>
<b>LASH IN MOUNTED COLUMN ASSEMBLY</b>	
<b>Cause</b>	<b>Solution</b>
<ul style="list-style-type: none"> <li>A. Instrument panel mounting bolts loose.</li> <li>B. Broken weld nuts on jacket.</li> <li>C. Instrument panel bracket capsule sheared.</li> <li>D. Instrument panel to jacket mounting bolts loose.</li> <li>E. Loose shoes in housing (tilt only).</li> <li>F. Loose tilt head pivot pins (tilt only).</li> <li>G. Loose shoe lock pin in support (tilt only).</li> </ul>	<ul style="list-style-type: none"> <li>A. Tighten to specifications. (20 ft. lbs.)</li> <li>B. Replace jacket assembly.</li> <li>C. Replace bracket assembly.</li> <li>D. Tighten to specifications. (15 ft. lbs.)</li> <li>E. Replace.</li> <li>F. Replace.</li> <li>G. Replace.</li> </ul>
<b>MISCELLANEOUS</b>	
<b>Cause</b>	<b>Solution</b>
<ul style="list-style-type: none"> <li>A. Housing loose on jacket - will be noticed with ignition in "Off-Lock" and a torque applied to the steering wheel.</li> <li>B. Shroud loose on shift bowl.</li> </ul>	<ul style="list-style-type: none"> <li>A. Tighten four mounting screws - (60 in. lbs.)</li> <li>B. Bend tabs on shroud over lugs on bowl.</li> </ul>

Fig. 113—Automatic Transmission Column Diagnosis



## MANUAL TRANSMISSION COLUMNS

### GENERAL INFORMATION

All of the preceding diagnosis information for automatic transmission will apply to the manual transmission. The following information is supplied in addition to and specifically for manual transmission columns.

### DRIVER CAN LOCK STEERING IN SECOND GEAR

Cause	Solution
<ul style="list-style-type: none"> <li>A. Defective upper shift lever.</li> <li>B. Defective shift lever gate.</li> <li>C. Loose relay lever on shift tube.</li> <li>D. Use of upper shift lever prior to 1969 model year.</li> </ul>	<ul style="list-style-type: none"> <li>A. Replace shift lever.</li> <li>B. Replace shift lever gate.</li> <li>C. Replace shift tube assembly.</li> <li>D. Replace with current lever.</li> </ul>

### HIGH SHIFT EFFORT

Cause	Solution
<ul style="list-style-type: none"> <li>A. Column not aligned correctly in car.</li> <li>B. Lower bowl bearing not assembled correctly.</li> <li>C. Improperly installed seal.</li> <li>D. Wave washer in lower bowl bearing defective.</li> <li>E. Improper adjustment of lower shift levers.</li> <li>F. Lack of grease on seal, bearing areas or levers.</li> <li>G. Damaged shift tube in bearing areas.</li> </ul>	<ul style="list-style-type: none"> <li>A. Realign column.</li> <li>B. Reassemble correctly.</li> <li>C. Remove and replace.</li> <li>D. Replace wave washer.</li> <li>E. Readjust (see Sec. 7).</li> <li>F. Lubricate seal, levers and bearings.</li> <li>G. Replace shift tube assembly.</li> </ul>

### IMPROPER TRANSMISSION SHIFTING

Cause	Solution
<ul style="list-style-type: none"> <li>A. Loose relay lever on shift tube.</li> </ul>	<ul style="list-style-type: none"> <li>A. Replace shift tube assembly.</li> </ul>

## TILT COLUMNS

### GENERAL INFORMATION

All of the preceding diagnosis will generally apply to tilt columns. The following is supplied in addition to and specifically for tilt columns.

### HOUSING SCRAPPING ON BOWL

Cause	Solution
<ul style="list-style-type: none"> <li>A. Bowl bent or not concentric with hub.</li> </ul>	<ul style="list-style-type: none"> <li>A. Replace bowl.</li> </ul>

Fig. 114—Manual Transmission Column Diagnosis

<b>STEERING WHEEL LOOSE</b>	
<b>Cause</b>	<b>Solution</b>
<ul style="list-style-type: none"> <li>A. Excessive clearance between holes in support or housing and pivot pin diameters.</li> <li>B. Defective or missing anti-lash spring in spheres.</li> <li>C. Upper bearing seat not seating in bearing.</li> <li>D. Upper bearing inner race seat missing.</li> <li>F. Loose support screws.</li> <li>G. Bearing preload spring missing or broken.</li> </ul>	<ul style="list-style-type: none"> <li>A. Replace either or both.</li> <li>B. Add spring or replace both.</li> <li>C. Replace both.</li> <li>D. Install seat.</li> <li>F. Tighten to 60 in. lbs.</li> <li>G. Replace preload spring.</li> </ul>
<b>STEERING WHEEL LOOSE EVERY OTHER TILT POSITION</b>	
<b>Cause</b>	<b>Solution</b>
<ul style="list-style-type: none"> <li>A. Loose fit between shoe and shoe pivot pin.</li> </ul>	<ul style="list-style-type: none"> <li>A. Replace both.</li> </ul>
<b>NOISE WHEN TILTING COLUMN</b>	
<b>Cause</b>	<b>Solution</b>
<ul style="list-style-type: none"> <li>A. Upper tilt bumper worn.</li> <li>B. Tilt spring rubbing in housing.</li> </ul>	<ul style="list-style-type: none"> <li>A. Replace tilt bumper.</li> <li>B. Lubricate.</li> </ul>
<b>STEERING COLUMN NOT LOCKING IN ANY TILT POSITION</b>	
<b>Cause</b>	<b>Solution</b>
<ul style="list-style-type: none"> <li>A. Shoe seized on its pivot pin.ivot pin.</li> <li>B. Shoe grooves may have burrs or dirt.</li> <li>C. Shoe lock spring weak or broken.</li> </ul>	<ul style="list-style-type: none"> <li>A. Replace shoe and pivot pin.</li> <li>B. Replace shoe.</li> <li>C. Replace lock spring.</li> </ul>
<b>STEERING WHEEL FAILS TO RETURN TO TOP TILT POSITION</b>	
<b>Cause</b>	<b>Solution</b>
<ul style="list-style-type: none"> <li>A. Pivot pins are bound up.</li> <li>B. Wheel tilt spring is defective.</li> <li>C. Turn signal switch wires too tight.</li> </ul>	<ul style="list-style-type: none"> <li>A. Replace pivot pins.</li> <li>B. Replace tilt spring.</li> <li>C. Reposition wires.</li> </ul>

Fig. 115—Tilt Column Diagnosis

## STEERING COLUMN ELECTRICAL ANALYZER J-23980 FOR C AND K SERIES COLUMNS

A new tool has been developed to help the technician analyze the steering column wiring harness for electrical problems. The tool in actuality eliminates the steering column, related wiring and components; and replaces them with the tool itself. In this way disassembly of the column is not performed until the problem has been determined to be in the column. By moving the tester switch, (with the key in the "on" position), the various functions may be checked. The switch positions are "OFF", "HORN", "LEFT TURN", "RIGHT TURN", "KEY BUZZER", and "HAZARD". (Trucks do not incorporate a Key Buzzer Switch) If the systems function properly while using the tester, then the malfunction has been narrowed to the column wiring or components. When this has been determined then the column may be serviced to correct the malfunction.

To use the tool just unfasten the harmonica connector on the column and plug the harness from J-23980 into the vehicle chassis harness. The "A", "B", and "C" terminals on the tester will overhang the chassis connector. This does not affect the test results. These terminals are for vehicles with cornering lights. Connect the single black jumper to a good ground. The tester is now ready for use (Fig. 116).

## TURN SIGNAL DIAGNOSIS C AND K SERIES

When a complaint is made involving the turn signal

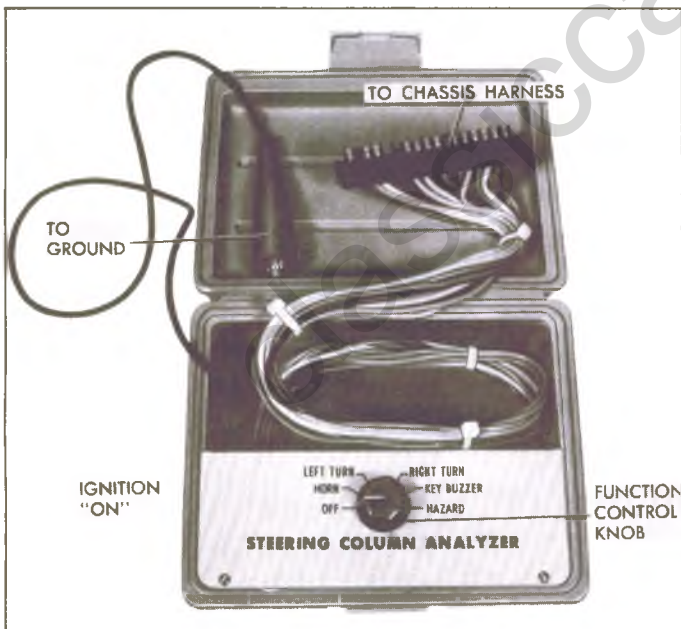

Fig. 116—Steering Column Electrical Analyzer J-23980

system, it must first be determined whether the problem is mechanical or electrical. If mechanical, the switch itself is at fault and must be repaired or replaced. If electrical, J-23980 should be used to determine whether the switch, or the chassis wiring is in need of repair or replacement.

This diagnostic procedure has been designed to guide the mechanic through the proper diagnosis and repair of the turn signal system. The service section is to be used where assembly and/or disassembly procedures are required. The wiring diagram, found in Section 12, should be used to trouble shoot the chassis and body wiring after the problem has been isolated.

The nature of the customer complaint will generally point to the problem area.

## ELECTRICAL

### Chassis Electrical

The most common turn signal system problems are generally electrical and may easily be fixed by the replacement of **fuses, bulbs or flashers**.

First make these checks and replace any non-operative components.

1. **Check fuses** (Figure 117). Replace if blown. If new fuse blows, replace flasher in system. (There are 2 flashers in the signal switch system. The hazard warning flasher is located on the fuse block, while the turn signal flasher is up under the instrument panel).

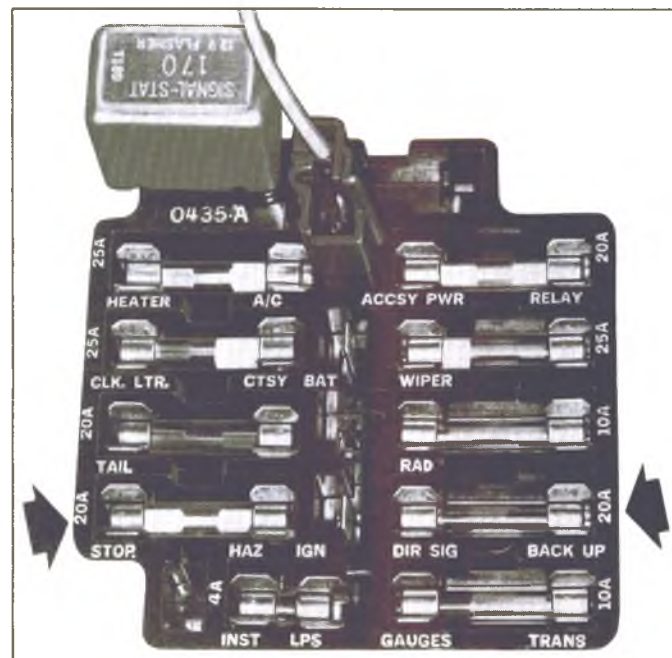

Fig. 117—Checking Fuses on Fuse Block

2. Check for secure connection at the chassis to switch connector. This is the harmonica connector on the column (Figure 118). Secure if loose. Check all individual wire terminals for proper seating in the connector bodies. Terminals should be locked in place.
3. Depress hazard warning button and check all lights in signal switch system. Replace any which do not work. If all lamps light when hazard warning is depressed, but flashing does not occur, replace hazard warning flasher. (On fuse block) (Figure 119).
4. If all directional lamps light when lane change or turn indicator is actuated, but no flashing occurs, replace the turn signal flasher. This flasher is located under the instrument panel.

The above four steps will, in most cases, cure the common signal switch system troubles. If the system is still not operating correctly, use J-23980 to determine whether the chassis wiring or the signal switch itself is at fault.

## MECHANICAL

1. If the customer's complaint indicates the problem is in the switch, function check as to return from full left and full right turns.

Actuate the turn lever into a full turn position in either direction, then turn the steering wheel (motor on — power steering) at least 1/4 turn in the direction indicated and then back to center. Do this in both directions. If the lever does not return to the neutral position, disassemble the upper part of the column until the switch is visible.

2. Check the return from lane change by holding the lever in lane change and releasing (both left and right). If the lever does not return to neutral, disassemble the upper part of the column.
3. If the hazard warning button cannot be depressed or released, the switch must be replaced.

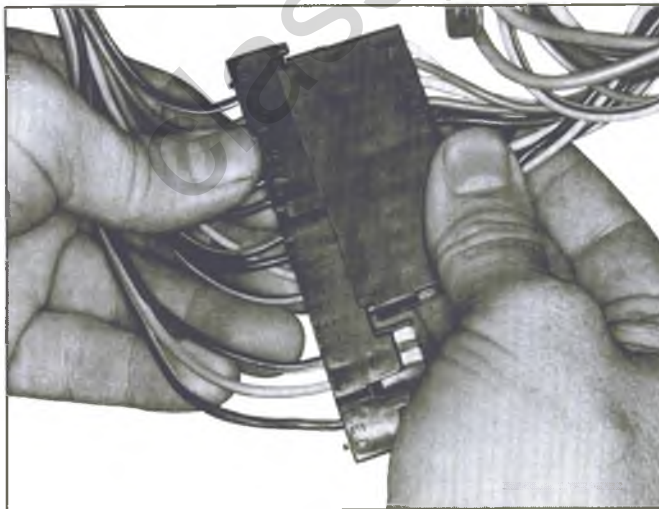

Fig. 118—Checking Harmonica Connector on Column

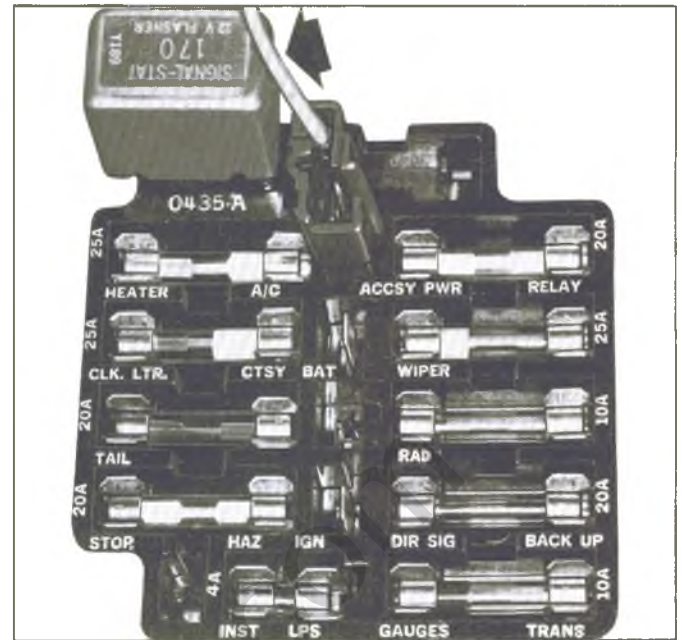

Fig. 119—Checking Hazard Warning Flasher

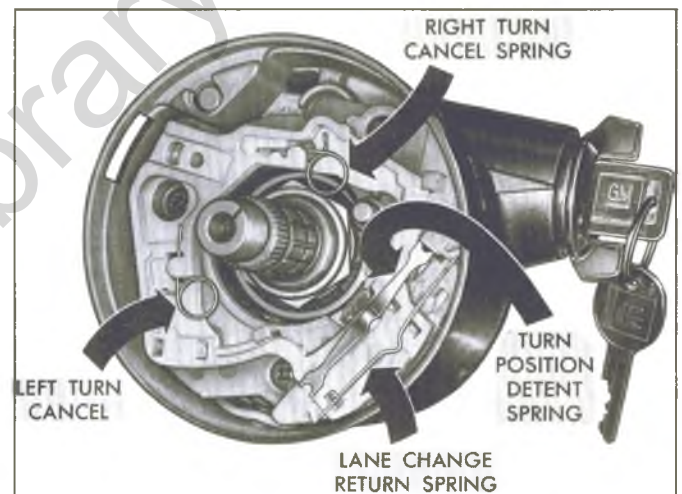

Fig. 120—Checking Turn Signal Switch Visually

### Switch Visual Inspection

1. With the upper part of the column disassembled so that the signal switch is visible (Figure 121) check for missing springs. Replace any spring that is missing, inspecting the molded pins which secure them. If these pins are broken, the switch must be replaced.
2. Check the position of the switch in the bowl. If it appears cocked or crooked, loosen the securing screws (3) and visually inspect the switch. If any of the plastic is broken or badly deformed, the switch must be replaced.
3. If the switch appears undamaged, replace it being careful to seat the pilot into the housing, tighten the screws to 25 in. lbs. of torque.

SIGNAL SWITCH DIAGNOSIS		
CONDITION	POSSIBLE CAUSE	CORRECTION
Turn signal will not cancel	<ul style="list-style-type: none"> <li>A. Loose switch mounting screws</li> <li>B. Switch or anchor bosses broken</li> <li>C. Broken, missing or out of position detent, return or cancelling spring</li> <li>D. Uneven or incorrect cancelling cam to cancelling spring interference. (.120)/side</li> </ul>	<ul style="list-style-type: none"> <li>A. Tighten to specified torque (25 in-lbs)</li> <li>B. Replace switch</li> <li>C. Reposition or replace springs as required</li> <li>D. Adjust switch position               <ul style="list-style-type: none"> <li>1. If interference is correct and switch will still not cancel, replace switch.</li> <li>2. If interference cannot be corrected by switch adjustment, replace cancelling cam.</li> </ul> </li> </ul>
Turn signal difficult to operate	<ul style="list-style-type: none"> <li>A. Actuator rod loose</li> <li>B. Yoke broken or distorted</li> <li>C. Loose or misplaced springs</li> <li>D. Foreign parts and/or materials</li> <li>E. Switch mounted loosely</li> </ul>	<ul style="list-style-type: none"> <li>A. Tighten mounting screw (12 in-lb)</li> <li>B. Replace switch</li> <li>C. Reposition or replace springs</li> <li>D. Remove foreign parts and/or material</li> <li>E. Tighten mounting screws (25 in-lbs)</li> </ul>
Turn signal will not indicate lane change	<ul style="list-style-type: none"> <li>A. Broken lane change pressure pad or spring hanger</li> <li>B. Broken, missing or misplaced lane change spring</li> <li>C. Jammed base or wires</li> </ul>	<ul style="list-style-type: none"> <li>A. Replace switch</li> <li>B. Replace or reposition as required</li> <li>C. Loosen mounting screws, reposition base or wires and retighten screws (25 in-lbs)</li> </ul>
Turn signal will not stay in turn position	<ul style="list-style-type: none"> <li>A. Foreign material or loose parts impeding movement of yoke</li> <li>B. Broken or missing detent or cancelling springs</li> <li>C. None of the above</li> </ul>	<ul style="list-style-type: none"> <li>A. Remove material and/or parts</li> <li>B. Replace spring</li> <li>C. Replace switch</li> </ul>
Hazard switch cannot be turned off	<ul style="list-style-type: none"> <li>A. Foreign material between hazard support cancelling leg and yoke</li> </ul>	<ul style="list-style-type: none"> <li>A. Remove foreign material               <ul style="list-style-type: none"> <li>1. No foreign material impeding function of hazard switch – replace turn signal switch</li> </ul> </li> </ul>

Fig. 121—Turn Signal Switch Diagnosis

SIGNAL SWITCH DIAGNOSIS		
CONDITION	POSSIBLE CAUSE	CORRECTION
Hazard switch will not stay on or difficult to turn off	<ul style="list-style-type: none"> <li>A. Loose switch mounting screws</li> <li>B. Interference with other components</li> <li>C. Foreign material</li> <li>D. None of the above</li> </ul>	<ul style="list-style-type: none"> <li>A. Tighten mounting screws (25 in-lbs)</li> <li>B. Remove interference</li> <li>C. Remove foreign material</li> <li>D. Replace switch</li> </ul>
No turn signal lights	<ul style="list-style-type: none"> <li>A. Defective or blown fuse</li> <li>B. Inoperative turn signal flasher</li> <li>C. Loose chassis to column connector</li> <li>D. Disconnect column to chassis connector. Connect new switch to chassis and operate switch by hand. If vehicle lights now operate normally, signal switch is inoperative</li> <li>E. If vehicle lights do not operate check chassis wiring for opens, grounds, etc.</li> </ul>	<ul style="list-style-type: none"> <li>A. Replace fuse and check operation</li> <li>B. Replace turn signal flasher</li> <li>C. Connect securely, check operation</li> <li>D. Replace signal switch</li> <li>E. Repair chassis wiring as required using manual as guide</li> </ul>
Turn indicator lights on, but not flashing	<ul style="list-style-type: none"> <li>A. Inoperative turn flasher</li> <li>B. Loose chassis to column connection</li> <li>C. Inoperative turn signal switch</li> <li>D. To determine if turn signal switch is defective, substitute new switch into circuit and operate switch by hand. If the vehicle's lights operate normally, signal switch is inoperative</li> <li>E. If the vehicle's lights do not operate, check light sockets for high resistance connections, the chassis wiring for opens, grounds, etc.</li> </ul>	<ul style="list-style-type: none"> <li>A. Replace turn flasher Note: There are two flashers in the system. Consult manual for location.</li> <li>B. Connect securely and check operation</li> <li>C. Replace turn signal switch</li> <li>D. Replace signal switch</li> <li>E. Repair chassis wiring as required using manual as guide</li> </ul>

Fig. 122—Turn Signal Switch Diagnosis

SIGNAL SWITCH DIAGNOSIS		
CONDITION	POSSIBLE CAUSE	CORRECTION
Front or rear turn signal lights not flashing	<p>A. Burned out fuse</p> <p>B. Burned out or damaged turn signal bulb</p> <p>C. High resistance connection to ground at bulb socket</p> <p>D. Loose chassis to column connector</p> <p>E. Disconnect column to chassis connector. Connect new switch into system and operate switch by hand. If turn signal lights are now on and flash, turn signal switch is inoperative.</p> <p>F. If vehicle lights do not operate, check chassis wiring harness to light sockets for opens, grounds, etc.</p>	<p>A. Replace fuse and check operation</p> <p>B. Replace bulb</p> <p>C. Remove or repair defective connection and check operation</p> <p>D. Connect securely and check operation</p> <p>E. Replace turn signal switch.</p> <p>F. Repair chassis wiring as required using manual as guide</p>
Stop light not on when turn indicated	<p>A. Burned out fuse</p> <p>B. Loose column to chassis connection</p> <p>C. Disconnect column to chassis connector. Connect new switch into system without removing old. Operate switch by hand. If brake lights work with switch in the turn position, signal switch is defective</p> <p>D. If brake lights do not work check connector to stop light sockets for grounds, opens, etc.</p>	<p>A. Replace fuse and check operation</p> <p>B. Connect securely and check operation</p> <p>C. Replace signal switch</p> <p>D. Repair connector to stop light circuits using manual as guide.</p>
Turn indicator panel lights not flashing	<p>A. Burned out bulbs</p> <p>B. High resistance to ground at bulb socket</p> <p>C. Opens, grounds in wiring harness from front turn signal bulb socket to indicator lights</p>	<p>A. Replace bulbs</p> <p>B. Replace socket</p> <p>C. Locate and repair as required. Use shop manual as guide.</p>

Fig. 123—Turn Signal Switch Diagnosis

SIGNAL SWITCH DIAGNOSIS		
CONDITION	POSSIBLE CAUSE	CORRECTION
Turn signal lights flash very slowly	<ul style="list-style-type: none"> <li>A. Inoperative turn signal flasher</li> <li>B. System charging voltage low</li> <li>C. High resistance ground at light sockets</li> <li>D. Loose chassis to column connection</li> <li>E. Disconnect column to chassis connector. Connect new switch into system without removing old. Operate switch by hand. If flashing occurs at normal rate, the signal switch is defective.</li> <li>F. If the flashing rate is still extremely slow, check chassis wiring harness from the connector to light sockets for grounds, high resistance points, etc.</li> </ul>	<ul style="list-style-type: none"> <li>A. Replace turn signal flasher</li> <li>B. Increase voltage to specified. See Sec. 6Y</li> <li>C. Repair high resistance grounds at light sockets</li> <li>D. Connect securely and check operation</li> <li>E. Replace signal switch</li> <li>F. Locate and repair as required. Use manual as guide. See Section 12</li> </ul>
Hazard signal lights will not flash — turn signal functions normally	<ul style="list-style-type: none"> <li>A. Blown fuse</li> <li>B. Inoperative hazard warning flasher</li> <li>C. Loose chassis to column connection</li> <li>D. Disconnect column to chassis connector. Connect new switch into system without removing old. Depress the hazard warning button and observe the hazard warning lights. If they now work normally, the turn signal switch is defective.</li> <li>E. If the lights do not flash, check wiring harness "K" lead (brown) for open between hazard flasher and harmonica connector. If open, fuse block is defective.</li> </ul>	<ul style="list-style-type: none"> <li>A. Replace fuse and check operation</li> <li>B. Replace hazard warning flasher</li> <li>C. Connect securely and check operation</li> <li>D. Replace the turn signal switch</li> <li>E. Replace fuse block (See Sec. 12)</li> </ul>

Fig. 124—Turn Signal Switch Diagnosis



## POWER STEERING SYSTEM DIAGNOSIS

Complaints of faulty steering are frequently the result of problems other than the steering gear or pump. Those areas of the steering system which can be easily checked and quickly corrected without disassembly and overhaul of any major components should be attempted first.

Conditions such as hard or loose steering, road shock or vibrations are not always due to the steering gear or pump, but are often related instead to such factors as low tire pressure and front end alignment. These factors should be checked and corrected before any adjustment or disassembly of the power steering gear or pump is attempted.

### SYSTEM CHECKS

Many factors affect power operation of the steering system, of which the most common are:

1. Fluid level and condition.
2. Drive belt tension.
3. Loose component mountings.
4. Loose pump pulley.

These factors must be checked and corrected before making any further diagnosis of the steering system. The need for proper diagnosis cannot be over-emphasized.

After the source of the problem has been found, determine the cause. For example, if the oil level in the reservoir is found to be low, refill and check the entire hydraulic system for oil leaks. Refilling the reservoir will not necessarily correct problem.

### Fluid Level

1. Run engine to normal operating temperature, then shut engine off. Remove reservoir filler cap and check oil level to "hot" mark on dipstick.
2. If oil level is low, add hydraulic fluid to proper level on dipstick and replace filler cap.

NOTE: When adding or making a complete fluid change, always use GM power steering fluid or equivalent.

3. When checking fluid level after the steering system has been serviced, air must be bled from the system. Proceed as follows:
  - a. With wheels turned all the way to the left, add power steering fluid to "Cold" mark on dipstick.
  - b. Start engine, and running at fast idle, recheck fluid level. Add fluid if necessary to "Cold" mark on dipstick.
  - c. Bleed system by turning wheels from side to side without hitting stops. Maintain fluid level just above internal pump casting. Fluid with air in it will have a light tan or red appearance. This air must be eliminated from fluid before normal steering action can be obtained.

- d. Return wheels to center position and continue to run engine for two or three minutes, then shut engine off.
- e. Road test car to make sure steering functions normally and is free from noise.
- f. Recheck fluid level as described in steps 1 and 2, making sure fluid level is at "hot" mark on dipstick after the system has stabilized at its normal operating temperature approximately 170° to 190°F.

### BELT ADJUSTMENT

When adjusting a power steering pump belt, never pry against the pump reservoir or pull against the filler neck. To increase belt tension move the pump outward by prying against the pump housing casting extension directly behind the pump drive pulley.

A belt that has been previously tensioned is considered to be a used belt and should be tightened to 75 pounds. A belt that has never been tensioned is considered to be a new belt and should be tightened to 125 pounds.

Place belt tension gage, J-23600 or equivalent midway between the pulleys on drive belt being checked. If the belt tension is incorrect proceed as follows:

1. When power steering pump is driven by a single belt:
  - a. Loosen the pump attaching bolts and adjust the belt to correct tension by moving the pump outward, away from the engine.
  - b. Snug all pump mounting bolts and remove pry bar.
  - c. Tighten all pump mounting bolts to specified torque.
  - d. Check belt tension and remove the belt tension gage.

### HYDRAULIC SYSTEM CHECKS

The following procedure outlines methods to identify and isolate power steering hydraulic circuit difficulties. The test provides means of determining whether power steering system hydraulic parts are actually faulty. This test will result in readings indicating faulty hydraulic operation, and will help to identify the faulty component.

Before performing hydraulic circuit test, carefully check belt tension, fluid level and condition of driving pulley.

### Power Steering Hydraulic System Test

Engine must be at normal operating temperature. Inflate front tires to correct pressure. All tests are made with engine idling, check idle adjustment and if necessary adjust engine idle speed to correct specifications listed in Section 6M and proceed as follows:

1. With engine NOT running disconnect pressure hose from pump and install Tool J-5176 using a spare

CONDITION	POSSIBLE CAUSE	CORRECTION
<p><b>SYSTEM NOISE</b></p> <p>There is some noise in all power steering systems.</p> <p>Common complaints are listed as follows:</p>		
Pump noise-"chirp".	Loose belt.	Adjust belt tension to specification.
Belt squeal.	Loose belt.	Adjust belt tension to specification.
Gear noise ("hissing" sound)	There is some noise in all power steering systems. One of the most common is a hissing sound most evident at standstill parking. There is no relationship between this noise and performance of the steering. "Hiss" may be expected when steering wheel is at end of travel or when slowly turning at standstill.	Do not replace valve unless "hiss" is extremely objectionable. Slight "hiss" is normal and in no way affects steering. A replacement valve will also exhibit slight noise and is not always a cure for the objection. Investigate clearance around flexible coupling rivets. Be sure steering shaft and gear are aligned so flexible coupling rotates in a flat plane and is not distorted as shaft rotates. Any metal-to-metal contacts through flexible coupling will transmit "hiss" into passenger compartment.
Rattle.	Pressure hose touching other parts of car. Loose pump pulley nut Pump vanes not installed properly. Pump vanes sticking in rotor slots.	Adjust hose position. Replace nut, torque to specs. Install properly. Free up by removing burrs, varnish or dirt.
Gear noise (rattle or chuckle).	Improper over-center adjustment  NOTE: A slight rattle may occur on turns because of increased clearance off the "high point". This is normal and clearance must not be reduced below specified limits to eliminate this slight rattle.  Loose pitman arm. Gear loose on frame.	Adjust to specifications.  Tighten to specifications Check gear-to-frame mounting bolts. Tighten bolts to 70 foot-pounds.
Rattle or chuckle.	Steering linkage looseness.	Check linkage pivot points for wear. Replace if necessary.
Groan.	Low oil level. Air in the oil. Poor pressure hose connection.	Fill reservoir to proper level. Bleed system by operating steering from right to left - full turn. Check connections, torque to specs.
Growl.	Excessive back pressure caused by hoses or steering gear. (restriction)	Locate restriction and correct. Replace part if necessary.

Fig. 125—Power Steering System Diagnosis

## 9-90 STEERING

CONDITION	POSSIBLE CAUSE	CORRECTION
Pump growl Note: Most noticeable at full wheel travel and stand still parking	Scored pump pressure plates, thrust plate or rotor.  Extreme wear of pump cam ring.	Replace affected parts, flush system.  Replace affected parts.
Swish in pump	Defective pump flow control valve	Replace valve
Whine in pump	Pump shaft bearing scored.	Replace housing and shaft, flush system
Squawk in gear (not belt)	Dampener "O" ring on valve spool cut	Replace "O" ring.
<b>SYSTEM OPERATION</b>  Excessive wheel kick-back or loose steering.	Backlash in steering linkage.  Air in system.  Excessive "over-center" lash.  Loose thrust bearing preload adjustment.  Worn poppet valve (Gear)  Steering gear loose on frame.  Steering gear flexible coupling too loose on shaft or rubber disc mounting screws loose.  Steering linkage ball studs worn enough to be loose.  Front wheel bearings incorrectly adjusted or worn.	Adjust parts affected or replace worn parts.  Add oil to pump reservoir and bleed by operating steering. Check all connections.  Adjust to specification.  Adjust to specification.  Replace poppet valve.  Tighten attaching bolts to 70 foot-pounds.  Tighten flange pinch bolts to 30 foot-pounds, if serrations are not damaged. Tighten upper flange to coupling nuts to 20 foot-pounds.  Replace loose components.  Adjust bearings or replace with new parts as necessary.
Poor return of steering.	Tires under-inflated.  Lower coupling flange rubbing against steering gear adjuster plug.  Steering wheel rubbing against directional signal housing.  Tight or frozen steering shaft bearings.  Steering linkage or ball joints binding.  Steering gear to column misalignment.  Tie rod pivots not centralized.  Lack of lubricant in suspension ball joints and steering linkage	Inflate to specified pressure.  Loosen pinch bolt and assemble properly.  Adjust steering jacket.  Replace bearings.  Replace affected parts.  Align steering column.  Adjust tie rod ends as required to center pivots.  Lubricate and relubricate at proper intervals

Fig. 126—Power Steering System Diagnosis

CONDITION	POSSIBLE CAUSE	CORRECTION
Poor return of steering. (Cont'd.)	Steering gear adjustments over specifications. Sticky or plugged valve spool. Rubber spacer binding in shift tube. Improper front suspension alignment. Tight steering shaft bearings.	Check adjustment with pitman arm disconnected. Readjust if necessary. Remove and clean or replace valve. Make certain spacer is properly seated. Lubricate inside diameter with silicone lubricant. Check and adjust to specifications. Replace bearings.
Vehicle leads to one side or the other. (Keep in mind road condition and wind. Test vehicle on flat road going in both directions)	Front suspension misaligned Steering shaft rubbing ID of shift tube. Unbalanced or badly worn steering gear valve. <b>NOTE:</b> If this is cause, steering effort will be very light in direction of lead and heavy in opposite direction. Steering linkage not level.	Adjust to specifications. Align column. Replace valve. Adjust as required.
Steering wheel surges or jerks when turning with engine running especially during parking.	Low oil level in pump. Loose pump belt. Sticky flow control valve. Insufficient pump pressure. Steering linkage hitting engine oil pan at full turn.	Check oil level, add as necessary. Adjust tension to specification. Inspect for varnish or damage, replace if necessary. Check pump pressure. (See pump pressure test). Replace relief valve if defective. Correct clearance.
Momentary increase in effort when turning wheel fast to right or left.	Pump belt slipping. Low oil level in pump. High internal leakage.	Tighten or replace belt. Check oil level, add as necessary. Check pump pressure (Test)
Hard steering or lack of assist.	High internal leakage. (Gear or pump) Loose pump belt. Low oil level in reservoir.	Check pump pressure. (See pump pressure test). Adjust belt tension to specification. Fill to proper level. If excessively low, check all lines and joints for evidence of external leakage, torque to specs.

Fig. 127—Power Steering Diagnosis

9-92 STEERING

CONDITION	POSSIBLE CAUSE	CORRECTION
<p>Hard Steering or lack of assist (Continued)</p>	<p>Lack of lubricant in suspension or ball joints.</p> <p>Tires not properly inflated.</p> <p>Steering gear to column misalignment.</p> <p>Steering gear adjusted too tight.</p> <p>Excessive friction in steering linkage.</p> <p>Lower coupling flange rubbing against steering gear adjuster plug.</p> <p>Sticky flow control valve.</p> <p>Frame bent.</p> <p>Front springs weak and sagging.</p> <p>Insufficient oil pressure.</p>	<p>Lubricate, relubricate at proper intervals.</p> <p>Inflate to recommended pressure.</p> <p>Align steering column.</p> <p>Test steering system for binding with front wheels off floor. Adjust as necessary.</p> <p>Check tie rod pivot points for excessive friction. Replace the affected pivot.</p> <p>Loosen pinch bolt and assemble properly.</p> <p>Replace or clean valve.</p> <p>Check frame for proper alignment or cracking. Repair or replace as necessary.</p> <p>Check standing height. Weak or sagging springs should be replaced with new ones.</p> <p>If above checks do not reveal cause of hard steering, diagnose hydraulic system to determine problem.</p>
<p>Low oil pressure due to restriction in hoses:</p>	<p>Check for kinks in hoses.</p> <p>Foreign object stuck in hose.</p>	<p>Remove kink.</p> <p>Remove hoses and remove restricting object or replace hose.</p>
<p>Low oil pressure due to steering gear:  (See pump pressure test)</p>	<p>Pressure loss in cylinder due to worn piston ring or scored housing bore.</p> <p>Leakage at valve rings, valve body to worm seal.</p> <p>Loose fit of spool in valve body or leaky valve body.</p> <p>Damaged poppet valve.</p>	<p>Remove gear for disassembly and inspection of ring and housing bore. Replace affected parts.</p> <p>Remove gear for disassembly and replace seals.</p> <p>Replace valve.</p> <p>Replace valve.</p>

Fig. 128—Power Steering System Diagnosis

CONDITION	POSSIBLE CAUSE	CORRECTION
<p>Low oil pressure due to steering pump: (See pump pressure test.)</p> <p>Note: Steering system external leakage</p> <p>Foaming milky power steering fluid, low level and possible low pressure.</p>	<p>Loose belt.</p> <p>Low oil level.</p> <p>Air in the oil.</p> <p>Defective hoses or steering gear.</p> <p>Flow control valve stuck or inoperative.</p> <p>Loose screw in end of flow control valve.</p> <p>Cracked or broken thrust or pressure plate.</p> <p>Pressure plate not flat against cam ring.</p> <p>Extreme wear of cam ring.</p> <p>Scored pressure plate, thrust plate or rotor.</p> <p>Vanes not installed properly.</p> <p>Vanes sticking in rotor slots.</p> <p>Air in the fluid, and loss of fluid due to internal pump leakage causing overflow.</p>	<p>Adjust tension to specification.</p> <p>Fill reservoir to proper level.</p> <p>Locate source of leak and correct. Bleed system.</p> <p>Correct as necessary.</p> <p>Remove burrs or dirt or replace.</p> <p>Tighten.</p> <p>Replace part.</p> <p>Replace pressure plate.</p> <p>Replace parts, flush system</p> <p>Replace parts. (If rotor, replace with rotating group kit), flush system</p> <p>Install properly. Radius edge to outside.</p> <p>Free-up by removing burrs, varnish or dirt.</p> <p>Check for leak and correct. Bleed system. Extremely cold temperatures will cause system aeration should the oil level be low. If oil level is correct and pump still foams, remove pump from vehicle and separate reservoir from housing. Check welsh plug and housing for cracks. If plug is loose or housing is cracked, replace housing.</p>

Fig. 129—Power Steering System Diagnosis

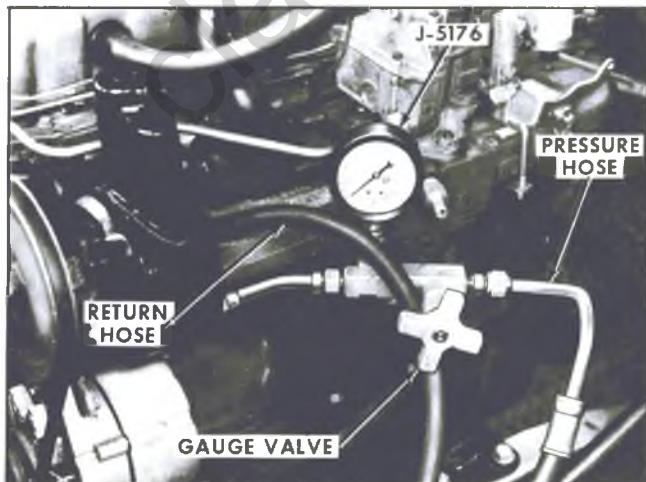

Fig. 130—Checking Power Steering Pressures

- pressure hose between gauge and pump. Gauge must be between shut-off valve and pump. Open shut-off valve.
2. Remove filler cap from pump reservoir and check fluid level. Fill pump reservoir to full mark on dip stick. Start engine and, momentarily holding steering wheel against stop, check connections at Tool J-5176 for leakage.
3. Bleed system as outlined under Maintenance and Adjustments.

## 9-94 STEERING

4. Insert thermometer (Tool J-5421) in reservoir filler opening. Move steering wheel from stop to stop several times until thermometer indicates that hydraulic fluid in reservoir has reached temperature of 150° to 170°F.

**CAUTION:** To prevent scrubbing flat spots on tires, do not turn steering wheel more than five times without rolling car to change tire-to-floor contact area.

5. Start engine and check fluid level adding any fluid if required. When engine is at normal operating temperature, the initial pressure read on the gage (valve open) should be in the 80-125 PSI range. Should this pressure be in excess of 200 PSI - check the hoses for restrictions and the poppet valve for proper assembly.
6. Close gate valve fully 3 times. Record the highest pressures attained each time. (Note: do not leave valve fully closed for more than 5 seconds as the pump could be damaged internally).
  - a. If the pressures recorded are within the listed specs and the range of readings are within 50 PSI, the pump is functioning within specs. (Ex. Spec. 900 - 1500 PSI - readings - 1270 - 1275 - 1280).
  - b. If the pressures recorded are high, but do not repeat within 50 PSI, the flow controlling valve is sticking. Remove the valve, clean it and remove any burrs using crocus cloth or fine hone. If the system contains some dirt, flush it. If it is exceptionally dirty, both the pump and the gear must be completely disassembled, cleaned, flushed and reassembled before further usage.
  - c. If the pressures recorded are constant, but more than 100 PSI, below the low listed spec., replace the flow control valve and recheck. If the pressures are still low, replace the rotating group in the pump.
7. If the pump checks within specifications, leave the valve open and turn (or have turned) the steering wheel into both corners. Record the highest pressures and compare with the maximum pump pressure recorded. If this pressure cannot be built in either (or one) side of the gear, the gear is leaking internally and must be disassembled and repaired. See the current Overhaul Manual.
8. Shut off engine, remove testing gage, spare hose, reconnect pressure hose, check fluid level and/or make needed repairs.

### POWER STEERING SYSTEM EXTERNAL LEAKAGE

#### General Procedure

1. Wipe suspected area dry.
2. Check for overfilled reservoir.

3. Check for oil aeration and overflow.
4. Check hose connections - tighten if necessary.
5. Verify exact point of leakage.

Example: Torison bar, stub shaft and adjuster seals are close together; exact leakage point could be confused.

Example: The point oil drips from is not necessarily the leakage point - oil overflowing from reservoir for instance.

6. When service is required:
  - A. Clean leakage area upon disassembly.
  - B. Replace leaking seal.
  - C. Check component sealing surfaces for damage.
  - D. Reset bolt torque to specifications where required.

Some of the customer complaints associated with the power steering system may be reported as:

1. Oil leakage on garage floor.
2. Oil leaks visible on steering gear, pump, or anywhere else on the left side of engine compartment.
3. Growling noise especially when parking or when engine is cold.
4. Loss of power when parking.
5. Heavy steering effort.

For the purpose of trouble shooting complaints of this nature, assume that there is an external leak in the power steering system.

### Leakage Diagnosis (Fig. 131)

This section is a guide, which when used in conjunction with your service manual will enable you, a service mechanic, to locate, identify, and repair leaks in the power steering system. It contains:

- A. Diagram of the complete power steering system with the areas of potential leakage identified.
- B. Recommended procedure for locating external leakage in the vehicle.
- C. Areas of leakage to be checked, which can be serviced at once.
- D. Part replacement recommendations.
- E. Diagram of the actual areas where leakage will be observed and the action recommended to repair this leakage.

### Leakage Check

The purpose of the diagnostic procedure is to pin-point the location of the leak. The method outlined in this manual can be followed to locate the leak and repair it.

In some cases you will be able to locate the leak easily. However, seepage type leaks may be more difficult to

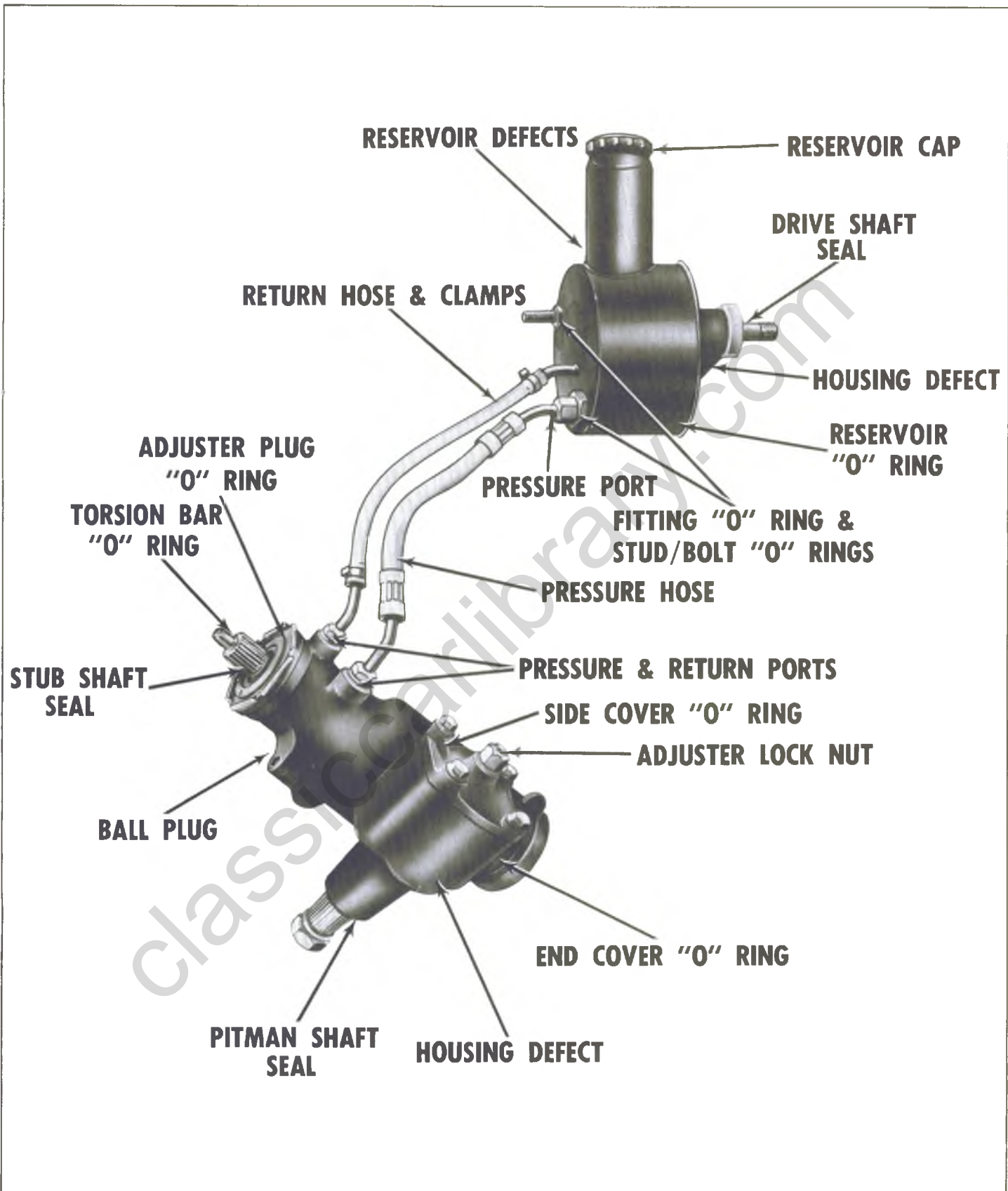

Fig. 131—Power Steering System Potential Leakage Areas



isolate. For seepage leaks, the following method is recommended.

- A. With the vehicle's engine off, wipe the complete power steering system dry (gear, pump, hoses, and connections).
- B. Check oil level in pump's reservoir and adjust as directed in maintenance section.
- C. Start engine and turn steering wheel from stop to stop several times. Do not hold in corner for any length of time as this can damage the power steering pump. It is easier if someone else operates the steering wheel while you search for the seepage.
- D. Find the exact area of leakage.
- E. Refer to the diagnostic chart to find the recommended method of repair.

### Quick Fixes

The purpose of this section is to acquaint you with the types of leakage which can be repaired very easily. It contains information on reservoir oil level, the hoses and the hose connections.

An overfilled pump reservoir can be a cause for leakage complaint. The oil in the steering system expands as heated during normal usage. If overfilled the excess is forced through the breather cap hole and may be sprayed over the engine by air blast. Operate the engine and steering system until normal operating temperature is obtained. Remove the reservoir cap and check the graduated level on the dipstick. Adjust the oil level as required.

Seepage at the hose connections can be a cause for leakage complaint and can be due to loose connection nuts. If leakage is observed at the hose connections, and the nut is not cross threaded, tighten the nuts at the gear to 30 foot pounds.

The nut at the power steering pump should be tightened to 40 foot pounds. If tightening to this torque does not stop the leak, refer to the diagnostic chart.

If either the return hose or the pressure hose leaks, replace the hose.

### Component Replacement

Lip seals, which seal rotating shafts, require special treatment. This type of seal is used on the steering gear at the pitman shaft, at the stub shaft, and on the drive shaft of the pump. When leakage occurs in one of these areas, always replace the seal(s), after inspecting and thoroughly cleaning the sealing surfaces. Replace the shaft only if very severe pitting is found. If the corrosion in the lip seal contact zone is slight, clean the surface of

the shaft with crocus cloth. Replace the shaft only if the leakage cannot be stopped by smoothing with crocus cloth first.

**Housing or Cover Seepage** - Both the power steering gear and pump assemblies are leakage checked before shipment. However, occasionally oil seepage may occur from the gear or pump other than the seal areas. If this type of leakage is found, replace the leaking part.

The following diagrams have been prepared to show the potential areas of leakage. If leakage occurs in the zones shown, replace the part listed using the service manual as a guide.

### STEERING GEAR LEAKAGE DIAGRAMS (Fig. 132)

Pay particular attention to the exact source of leakage as an improper diagnosis will result in an ineffective repair.

1. Replace adjuster plug "O" RING SEAL.
2. Replace dust and stub shaft seals. Refer to above on stub shaft seal ride.
3. Replace rotary valve assembly.
4. Seat ball flush with punch and restake. If seepage persists, replace housing.
5. Replace both pitman shaft seals. Refer to above on seal ride area of pitman shaft.
6. Replace end plug "O" ring seal.
7. Tighten nut to 35 foot pounds. Replace nut if leakage persists.
8. Replace side cover "O" ring seal.
9. If leakage persists upon tightening the fitting nut (30 foot pounds), replace brass connector and reface hose tube flare. If leakage is due to damaged threads (cross threaded), replace brass connector. Repair fitting nut or replace hose as required. If housing threads are badly stripped, replace housing.

### PUMP LEAKAGE DIAGRAMS (Fig. 133)

10. Tighten hose fitting nut to 40 foot pounds. If leakage persists, replace discharge fitting and reface hose tube flare or replace hose as required.
11. Tighten fitting to 35 foot pounds. If leakage persists, replace both "O" ring seals.
12. Replace reservoir "O" ring.
13. Replace drive shaft seal. Refer to above on seal ride area of drive shaft.
14. Replace reservoir.
15. Check oil level. If leakage persists with the level right and the cap tight, replace the cap.

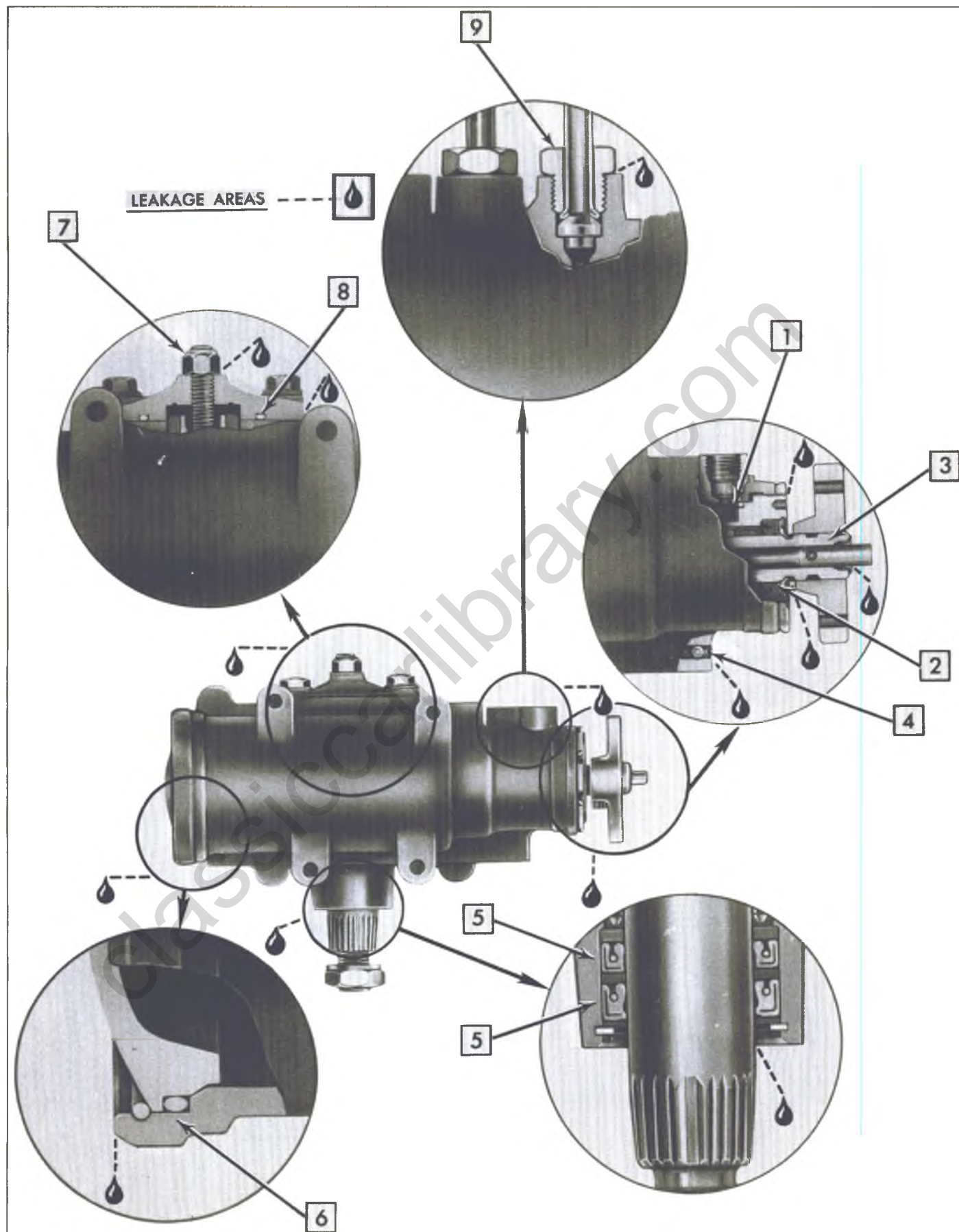

Fig. 132—Power Steering Gear Leakage

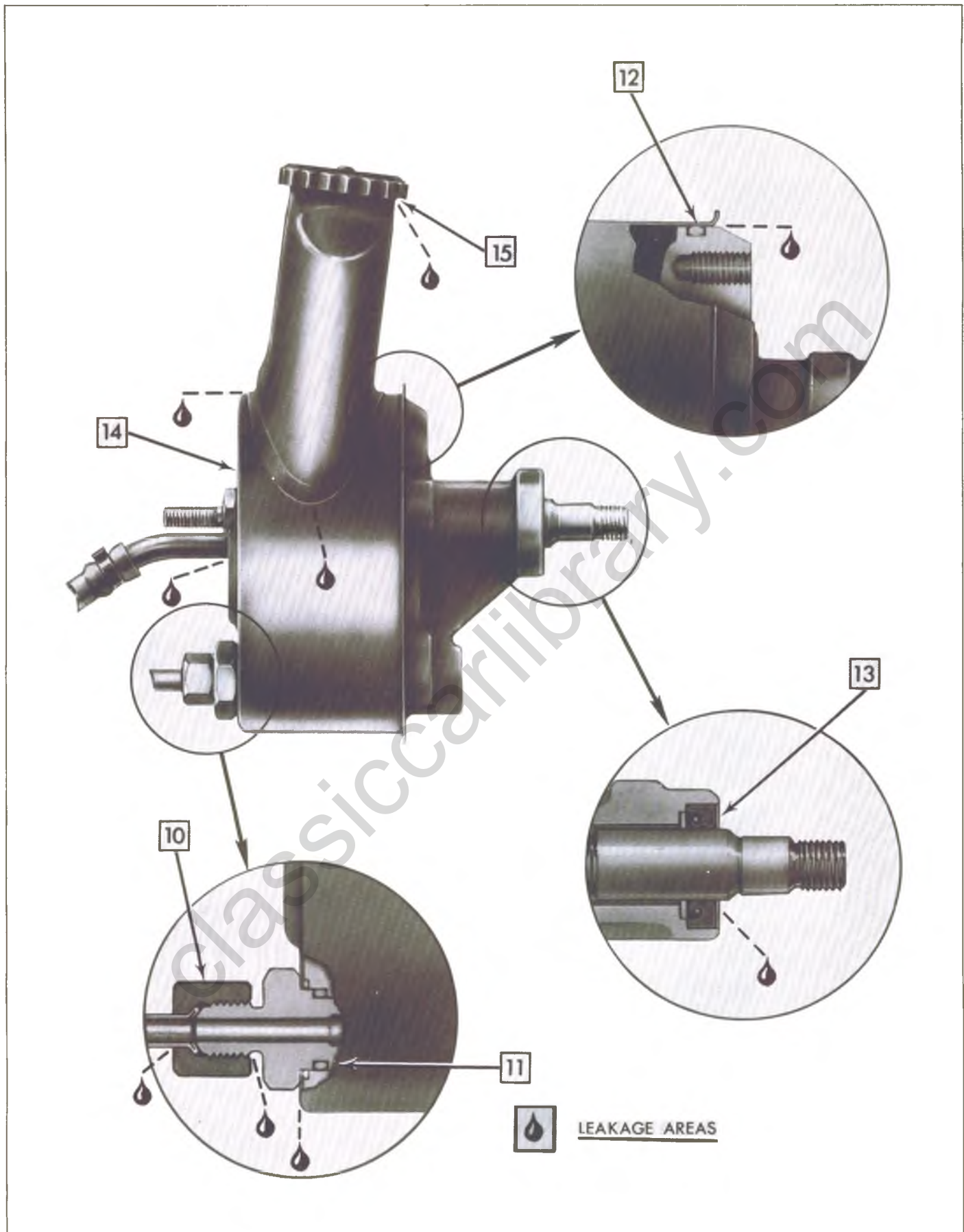

Fig. 133—Power Steering Pump Leakage

## SPECIAL TOOLS

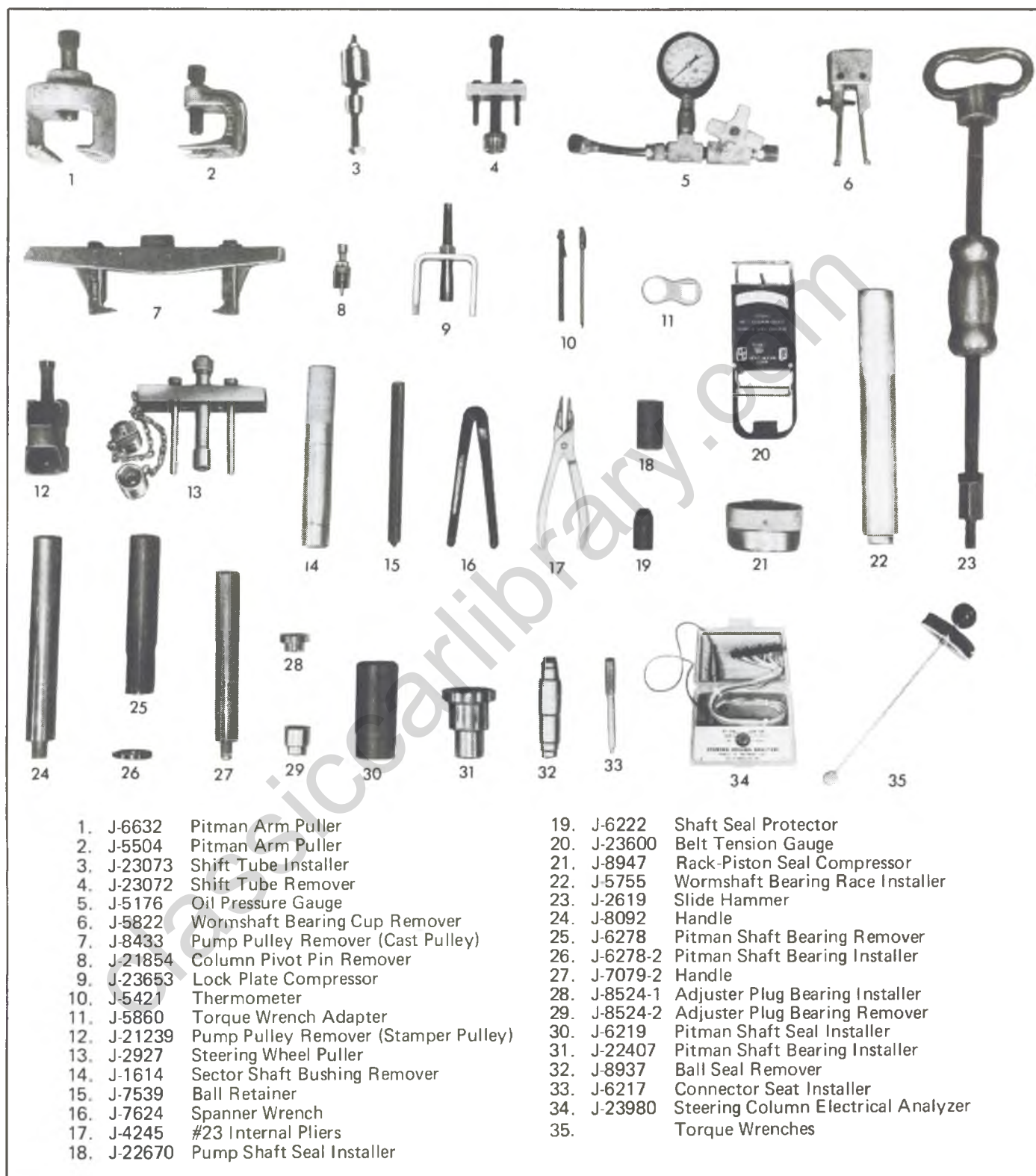

Fig. 134—Special Tools C and K



- |             |                                 |              |                                 |
|-------------|---------------------------------|--------------|---------------------------------|
| 1. J-6632   | Pitman Arm Puller               | 19. J-6278   | Pitman Shaft Bearing Remover    |
| 2. J-5504   | Pitman Arm Puller               | 20. J-6278-2 | Pitman Shaft Bearing Installer  |
| 3. J-5176   | Pressure Gauge                  | 21. J-7079-2 | Drive Handle                    |
| 4. J-5822   | Wormshaft Bearing Cup Puller    | 22. J-8524-1 | Adjuster Plug Bearing Installer |
| 5. J-5860   | Torque Wrench Adapter           | 23. J-8524-2 | Adjuster Plug Bearing Remover   |
| 6. J-22670  | Pump Shaft Seal Installer       | 24. J-6219   | Pitman Shaft Seal Installer     |
| 7. J-6222   | Shaft Seal Protector            | 25. J-6217   | Connector Seat Installer        |
| 8. J-9226   | Pitman Shaft Bushing Replacer   | 26. J-5421   | Thermometer                     |
| 9. J-7576   | Rack-Piston Seal Compressor     | 27. J-22407  | Pitman Shaft Bearing Installer  |
| 10. J-21239 | Pump Pulley Remover             | 28. J-22727  | Terminal Remover                |
| 11. J-2927  | Steering Wheel Puller           | 29. J-22708  | Turn Signal Cover Remover       |
| 12. J-1614  | Sector Shaft Bushing Remover    | 30. J-22573  | Steering Column Holding Fixture |
| 13. J-7539  | Ball Retainer                   | 31. J-22599  | Lock Nut Socket                 |
| 14. J-7624  | Spanner Wrench                  | 32. J-21854  | Pivot Pin Remover               |
| 15. J-4245  | #23 Internal Pliers             | 33. J-22551  | Shift Tube Remover              |
| 16. J-23600 | Belt Tension Gauge              | 34. J-22549  | Shift Tube Installer            |
| 17. J-5755  | Wormshaft Bearing Cup Installer | 35. - - -    | Torque Wrenches                 |
| 18. J-2619  | Slide Hammer                    |              |                                 |

Fig. 135—Special Tools G and P

## SECTION 10 WHEELS AND TIRES

### INDEX

General Description .....	10-1	Correcting Irregular Tire Wear .....	10-6
Maintenance .....	10-2	Wheel Removal and Installation .....	10-7
Wheel Nut Torques.....	10-2	Tire Mounting and Demounting.....	10-8
Tire Rotation .....	10-2	RHP Rims.....	10-9
Tire Inflation Pressure.....	10-2	RHP Rim Tire Mounting and Demounting .....	10-9
Service Operations .....	10-6		

## GENERAL DESCRIPTION

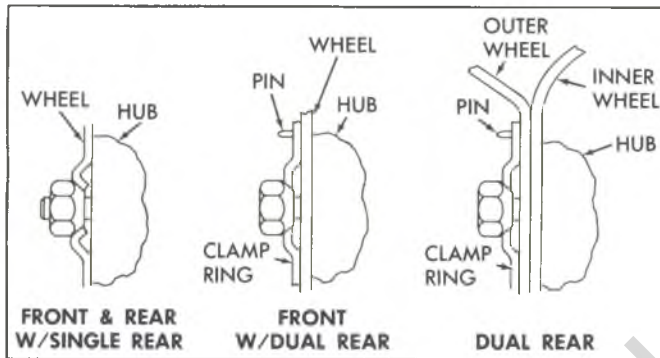

Fig. 1—Wheel Attachments

The 1974 truck is equipped with a wide range of tube or tubeless type tires and wheels selected according to the truck Gross Vehicle Weight Rating (GVWR) and type of service. The dual rear wheel option is available on Series 30 trucks. The factory installed bias belted tires are selected to provide the best all around tire performance for all normal operations. All tires are manufactured for use on wheels of specific size, configuration and load carrying capacity. When replacing a worn or damaged tire it is essential that you use a replacement tire of the same size and load rating as that with which the vehicle was equipped when manufactured. Use of any other size of tire may seriously affect ride, handling, ground clearance, tire clearance and speedometer calibration. Similarly, use of wheels with offsets other than

recommended, or use of what are commonly referred to as "reversed rims" may seriously overload wheel bearings or other axle components causing rapid wear or failure of these parts and void the vehicle warranty. To achieve best all around vehicle handling performance, belted tires and bias ply tires should not be mixed on the same truck. Because of possible adverse effects on vehicle handling, do not mix radial ply tires with other type tires on the same vehicle.

**NOTE:** On four-wheel drive vehicles all tires must be of equal size (but not necessarily ply rating) and of same tread configuration.

### TUBELESS TIRES

These tires have an inner liner which, if punctured, tends to cling to the penetrating object forming a partial seal until the object is removed from the tire. It is essential to conduct a periodic pressure check according to the tire inflation tables on the following pages plus a visual tire inspection to detect imbedded objects which might otherwise go unnoticed and cause serious casing damage.

### TUBE TIRES

Some commercial vehicles are equipped (at customer option) with synthetic rubber tires and tubes.

## THEORY

### TIRE TRACTION

A decrease in driving, cornering, and braking traction occurs when water, snow, ice, gravel, or other material is on the road surface. Driving practices and truck speed should be adjusted to the road conditions.

When driving on wet or slushy roads, it is possible for a wedge of water to build up between the tire and road surface. This phenomenon, known as hydroplaning, may cause partial or complete loss of traction, which adversely affects vehicle control and stopping ability. To

reduce the possibility of traction loss, the following precautions should be observed.

1. Slow down during rainstorms or when roads are slushy.
2. Slow down if road has standing water or puddles.
3. Replace tires when tread depth becomes 1/16".
4. Keep tires properly inflated.

### Puncture Inspection and Repair

At each lubrication, tires should be checked for foreign

## 10-2 WHEELS AND TIRES

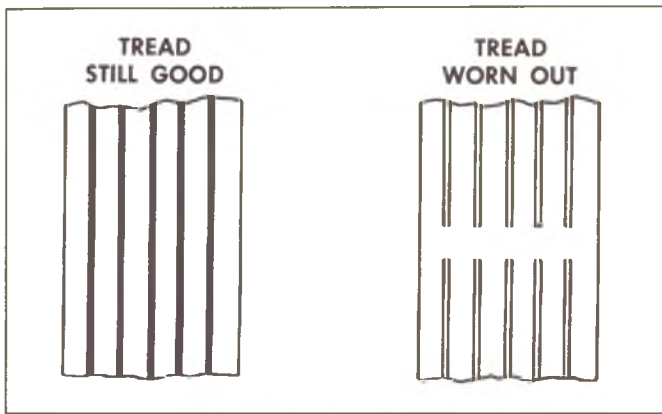

Fig. 2—Passenger Type Tire Tread Wear

objects in the tread or breaks in the tread or sidewall. If

tire is punctured or otherwise damaged, it should be repaired using one of several repair kits available through tire manufacturers outlets.

### Tread Wear

When the depth of tread becomes 1/16-inch or less, there is a significant decrease in traction and anti-skid properties, also, the majority of tire troubles will occur in the last 10% of tire life.

The original equipment passenger type tires on Series 10 trucks incorporate built in tread indicators to assist in judging when tires are worn out and should be replaced.

These indicators are molded into the bottom of the tread groove and will appear as bands across the tread as a visual reminder that the tire should be replaced (see fig. 2).

## MAINTENANCE

### WHEEL NUT TORQUES

On a new vehicle or after the wheel has been changed, the wheel nut torque must be checked at 100, 1,000 and 6,000 miles and every 6,000 miles thereafter.

### TIRE ROTATION

The rotation of truck tires will minimize tire trouble and produce longer tire life. With rotation, accelerated and irregular tire wear on any one particular tire will be spread out over the entire set, and replacement frequency will be reduced. Tire wear may also contribute to such trouble as poor handling and shimmy.

No definite tire rotation formula is applicable to all trucks because of the wide range of usage. However, certain fundamentals, mixed with experience and observation, will assist the trucker in reducing tire costs.

A rotation sequence that moves the front tires to the rear is a general recommendation. Due to different loading conditions on the wheels, new tires which are broken in on the front wheels usually produce the greatest overall tire life.

The outer tire on a dual wheel will skid or drag on a turn because of the difference in the turning radii of the inner and outer tires. This results in faster wear of the outer tire. In general, the tire with the largest diameter or least wear should be at the outside of each dual wheel. In addition, certain truckers have found when trucks are operated continuously on high crown roads an increase in air pressure of from 5 to 10 pounds in the outside tire of each dual produces maximum tire life.

To equalize wear it is recommended that the tires be rotated every 6,000 miles. Upon rotation, tire pressure must be adjusted (front and rear) in accordance with the recommendations for inflation pressure.

### Inflation Pressure

Standard inflation pressures for tires are listed in the "Minimum Tire Inflation Pressure at Gross Vehicle Weight Rating Charts" on the following pages. Front and rear pressures are shown for each model and GVWR and are based on the GVWR and front and rear axle ratings (GAWR's) printed on the vehicle's VIN Plate and Certification Label. Tires must be inflated to these pressures when the vehicle is fully loaded.

Lower inflation pressures are allowable only with a reduced load in the vehicle. After determining the load on each tire by weighing the vehicle on a scales, the corresponding inflation pressures for the reduced loads can be obtained from the "Tire Load and Inflation pressure chart". When operating at loads greater than the optional reduced load, the inflation pressure must be increased to the standard inflation for full rated loads. On K10 or K15 4-Wheel drive Pick-Ups and utility vehicles with passenger type tires, reduced tire pressures are recommended for front tires only, optimum ride and handling require full maximum inflation pressure in the rear tires at all times.

The use of improper tire inflation pressures can affect tire life and load carrying capacity, and may affect vehicle handling. Inflation pressures should be checked at least once a month (and preferably more often) to insure that the right amount of air is contained in the tires. With regard to tire life, too little air pressure allows abnormal deflection of the tire causing excessive operating temperatures, while too much air pressure prevents normal deflection, making the cord body more vulnerable to road impacts.

Use of optional inflations is allowable only with a reduced load as shown in the "Tire Load and Inflation Pressure Chart." When operating at loads greater than the optional reduced load, the inflation pressure must be

increased to the standard inflation for full rated loads. On K10 4 wheel drive Pick-Ups and Utility vehicles with passenger type tires, reduced tire pressures are

recommended for front tires only. Optimum ride and handling require full maximum inflation pressure in the rear tires at all times.

MINIMUM TIRE INFLATION PRESSURE AT GROSS VEHICLE WEIGHT RATING (GVWR) (Lbs.)

		C, K 105 UTILITY						K10, 15 PICKUP						K10, 15 SUBURBAN						P10, 15																	
		2 WHEEL DRIVE			4 WHEEL DRIVE			4 WHEEL DRIVE						4 WHEEL DRIVE																							
GVWR (Lbs.)→		4900		5200		5700		4900		5350		5800 & 6200		5200		5600		6000		5600		6000		6600		7150		4900		5200		5600		6000			
TIRE	LOAD RANGE	FR	R	FR	R	FR	R	FR	R	FR	R	FR	R	FR	R	FR	R	FR	R	FR	R	FR	R	FR	R	FR	R	FR	R	FR	R	FR	R	FR	R		
E78-15	B	32	32	—	—	—	—	32	32	—	—	—	—	—	—	—	—	—	—	—	—	—	—	—	—	—	—	—	—	—	—	—	—	—	—	—	—
G78-15	B	—	—	32	32	—	—	—	—	32	32	—	—	32	32	—	—	—	—	32	32	—	—	—	—	—	—	—	—	—	—	—	—	32	32	32	32
*6.50-16LT	C	—	—	45	45	45	45	—	—	45	45	45	45	45	45	45	45	—	—	45	45	45	45	—	—	—	—	—	—	—	—	—	—	45	45	45	45
H78-15	B	—	—	32	32	32	32	—	—	32	32	32	32	32	32	32	32	—	—	32	32	32	32	—	—	—	—	—	—	—	—	—	—	30	32	30	32
*7.00-15LT	C	—	—	45	45	45	45	—	—	45	45	45	45	45	45	45	45	45	45	45	45	45	45	—	—	—	—	—	—	—	—	—	—	40	45	40	45
*10-15LT	B	—	—	—	—	—	—	—	—	—	—	—	—	—	—	—	—	—	—	—	—	—	—	—	—	—	—	—	—	—	—	—	—	—	—	—	—
L78-15	B	—	—	28	30	28	30	—	—	30	30	30	30	30	32	30	32	30	32	30	32	30	32	30	32	30	32	30	32	—	—	—	—	26	32	26	32
*7.00-16LT	C	—	—	40	40	40	45	—	—	45	45	45	45	45	45	45	45	45	45	45	45	45	45	—	—	—	—	—	—	—	—	—	—	35	45	35	45
LR78-15	C	—	—	28	30	28	30	—	—	30	30	30	30	30	36	30	36	30	36	30	36	30	36	—	—	—	—	—	—	—	—	—	—	26	32	26	32
L78-15	D	—	—	—	—	—	—	—	—	—	—	—	—	—	—	—	—	—	—	—	—	—	—	—	—	—	—	—	—	—	—	—	—	—	—	—	—

		K20, 25 PICKUP & SUBURBAN						P20, 25						P30, 35 SINGLE WHEEL				
GVWR (Lbs.)→		6800		7500		8200		6800		7500		8000		7600		9000		
TIRE	LOAD RANGE	FR	R	FR	R	FR	R	FR	R	FR	R	FR	R	FR	R	FR	R	
8.75-16.5	C	40	45	40	—	—	—	40	45	40	—	—	—	45	—	—	—	
8.75-16.5	C	40	60	40	60	—	—	40	60	40	60	—	—	50	60	—	—	
9.50-16.5	D	30	60	—	—	30	60	30	60	—	—	30	60	35	60	35	—	
10-16.5	C	30	45	—	—	—	—	30	45	—	—	—	—	—	—	—	—	
7.50-16LT	C	35	45	35	—	35	—	40	45	40	—	40	—	45	—	—	—	
7.50-16LT	D	35	60	35	60	35	—	40	60	40	60	40	—	45	60	—	—	
7.50-16LT	E	35	75	—	—	35	75	40	75	—	—	40	75	45	75	—	—	
9.50-16.5	E	—	—	—	—	—	—	—	—	—	—	—	—	35	75	35	75	

		P30, 35 DUAL WHEELS							
GVWR (Lbs.)→		9000		10000		12000		14000	
TIRE	LOAD RANGE	FR	R	FR	R	FR	R	FR	R
8.00-16.5	D	60	50	60	60	—	—	—	—
7.50-16LT	C	45	35	45	45	—	—	—	—
7.50-16LT	D	45	35	45	45	—	—	—	—
7.00-18	D	55	40	55	45	—	—	—	—
8-19.5	D	—	—	—	—	50	65	50	—
8-19.5	E	—	—	—	—	—	—	50	80

MINIMUM TIRE INFLATION PRESSURE AT GROSS VEHICLE WEIGHT RATING (GVWR) (Lbs.)

		C10, 15 PICKUPS & CAB-CHASSIS						C10, 15 SUBURBANS							
GVWR (Lbs.)→		4900		5300		5400		6000		5400		6000		6800	
TIRE	LOAD RANGE	FR	R	FR	R	FR	R	FR	R	FR	R	FR	R	FR	R
G78-15	B	32	32	32	32	—	—	—	—	—	—	32	32	—	—
H78-15	B	32	32	—	—	32	32	—	—	32	32	32	32	—	—
6.50-16LT	C	45	45	—	—	45	45	—	—	45	45	45	45	—	—
7.00-15LT	C	40	45	—	—	40	45	—	—	40	45	—	—	—	—
L78-15	B	28	32	—	—	28	32	28	32	28	32	28	32	—	—
7.00-16LT	C	40	45	—	—	40	45	40	45	40	45	40	45	—	—
LR78-15	C	28	36	—	—	28	36	28	36	28	36	28	36	28	36
L78-15	D	—	—	—	—	—	—	—	—	—	—	28	36	28	36

		C20, 25 PICKUP & CAB-CHASSIS				C20, 25 SUBURBAN				C30, 35 PICKUP & CAB-CHASSIS											
GVWR (Lbs.)→		6400		7500		8200		7100		7500		8200		6600		8200		9000		9600	
TIRE	LOAD RANGE	FR	R	FR	R	FR	R	FR	R	FR	R	FR	R	FR	R	FR	R	FR	R	FR	R
8.75-16.5	C	45	45	—	—	—	—	45	45	—	—	—	—	45	45	—	—	—	—	—	—
8.75-16.5	D	45	60	—	—	—	—	45	60	—	—	—	—	45	60	—	—	—	—	—	—
7.50-16LT	C	40	45	—	—	—	—	40	45	—	—	—	—	40	45	—	—	—	—	—	—
10-16.5	C	35	45	—	—	—	—	—	—	—	—	—	—	35	45	—	—	—	—	—	—
7.50-16LT	D	40	60	—	—	—	—	40	60	—	—	—	—	40	60	—	—	—	—	—	—
7.50-16LT	E	40	75	40	75	40	75	40	75	40	75	40	75	40	75	40	75	—	—	—	—
9.50-16.5	D	35	60	35	60	35	60	35	60	35	60	35	60	35	60	35	60	35	—	—	—
9.50-16.5	E	—	—	—	—	—	—	—	—	—	—	—	—	35	75	35	75	35	75	35	75

		C30, 35 PICKUP & CAB-CHASSIS DUAL REAR WHEELS					
GVWR (Lbs.)→		8000		9000		10000	
TIRE	LOAD RANGE	FR	R	FR	R	FR	R
7.00-16LT	C	45	45	45	45	—	—
8.00-16.5	D	45	60	45	60	45	60
7.50-16LT	C	40	45	40	45	40	45
8.75-16.5	C	45	45	45	45	45	45
8.75-16.5	D	45	60	45	60	45	60
7.50-16LT	D	40	60	40	60	40	60



# 10-4 WHEELS AND TIRES

## MINIMUM TIRE INFLATION PRESSURE AT GROSS VEHICLE WEIGHT RATING (GVWR) (Lbs.)

CHEVY VAN																												
		G11005				G11305				G21005				G21305				G31005										
GVWR (Lbs.) →		4500		5000		4600		5100		5500		6000		5600		6000		6200		6900		7100		7700		8100		
TIRE	LOAD RANGE	FR	R	FR	R	FR	R	FR	R	FR	R	FR	R	FR	R	FR	R	FR	R	FR	R	FR	R	FR	R	FR	R	
E78-14	B	32	28																									
F78-14	B			32	32	30	24	32	32																			
7.00-14LT	C					45	40																					
7.00-14LT	D			60	60			60	60																			
G78-15	B									32	32			32	32													
G78-15	D											32	40			32	40											
H78-15	B											32	32			32	32											
HR78-15	B											32	32			32	32											
H78-15	D											32	38			32	38											
6.70-15LT	C									45	45			45	45													
8.25-15	D											32	40					32	40									
8.00-16.5	C																	40	45	45	45							
8.00-16.5	D																					45	65					
8.00-16.5	E																						45	65	60	75		
8.75-16.5	C																					35	45					
8.75-16.5	D																						35	50	45	60		
8.75-16.5	E																										45	75

CHEVY VAN														CUTAWAY			
		G31305										G31303					
GVWR (Lbs.) →		6400		7100		7300		7900		8300		8400		8900*			
TIRE	LOAD RANGE	FR	R	FR	R	FR	R	FR	R	FR	R	FR	R	FR	R		
8.00-16.5	C	45	45											45	45		
8.00-16.5	D			45	65												
8.00-16.5	E					45	65	60	75								
8.75-16.5	C			35	40												
8.75-16.5	D					35	50	45	60								
8.75-16.5	E									45	75	45	75				
9.50-16.5	D									60							

\*Dual Rear Tires.

SPORT VAN																												
		G11006				G11306				G21006				G21306				G31306										
GVWR (Lbs.) →		5200		5400		5400		5700		6200		5800		6400		6600		7100		7300		7800		8300				
TIRE	LOAD RANGE	FR	R	FR	R	FR	R	FR	R	FR	R	FR	R	FR	R	FR	R	FR	R	FR	R	FR	R	FR	R	FR	R	
F78-14	B	32	32																									
G78-14	B			32	32	32	32																					
G78-15	B							32	32			32	32															
G78-15	D									38	40			38	40													
H78-15	B									32	32			32	32													
HR78-15	B									32	32			32	32													
J78-15	B									30	32			30	32													
8.28-15	D									38	40			38	40													
6.70-15LT	C									45	45			45	45													
8.00-16.5	C									40	45			40	45	45	45											
8.00-16.5	D																	45	65									
8.00-16.5	E																			45	65	45	65	60	75			
8.75-16.5	C																			35	45							
8.75-16.5	D																				35	50	45	60				
8.75-16.5	E																									45	75	

**TIRE LOAD & INFLATION PRESSURE  
PASSENGER TYPE TIRES FOR LIGHT TRUCKS USED IN HIGHWAY SERVICE**

Tire Size	Range Load	Tire Load Limits at Various Inflation Pressures											
		20	22	24	26	28	30	32	34	36	38	40	
E78-15	B	973	1027	1082	1127	1182	1227	<u>1273</u>					
E78-14	B	973	1027	1082	1127	1182	1227	<u>1273</u>					
F78-14	B	1054	1109	1164	1218	1272	1318	<u>1364</u>					
G78-14	B	1136	1191	1255	1309	1364	1418	<u>1473</u>					
G78-15	B	1136	1191	1255	1309	1364	1418	<u>1473</u>					
G78-15	D	1136	1191	1255	1309	1364	1418	<u>1473</u>	1528	1572	1619	<u>1664</u>	
H78-15	B	1236	1309	1373	1436	1500	1555	<u>1609</u>					
H78-15	D	1236	1309	1373	1436	1500	1555	<u>1609</u>	1664	1719	1774	<u>1827</u>	
HR78-15	B	1236	1309	1373	1436	1500	1555	<u>1609</u>					
J78-15	B	1300	1363	1437	1500	1564	1628	<u>1691</u>					
G78-15	B	1136	1191	1255	1309	1364	1418	<u>1473</u>					
G78-15	D	1136	1191	1255	1309	1364	1418	<u>1473</u>	1528	1572	1619	<u>1664</u>	
H78-15	B	1236	1309	1373	1436	1500	1555	<u>1609</u>					
H78-15	D	1236	1309	1373	1436	1500	1555	<u>1609</u>	1664	1719	1774	<u>1827</u>	
L78-15	B	1382	1455	1527	1591	1664	1727	<u>1791</u>					
LR78-15	C	1382	1455	1527	1591	1664	1727	<u>1791</u>	1855	<u>1909</u>			
L78-15	D	1382	1455	1527	1591	1664	1727	<u>1791</u>	1855	<u>1909</u>	1973	<u>2024</u>	
8.25-15	D	1136	1191	1255	1309	1364	1418	<u>1473</u>	1528	<u>1572</u>	1619	<u>1664</u>	
10.00-15	B	1390	1470	1540	1620	1690	1760						

**TIRES FOR LIGHT TRUCKS USED IN HIGHWAY SERVICE  
TIRES USED AS SINGLES**

Tire Size	Load Range	Tire Load Limits at Various Inflation Pressures											
		30	35	40	45	50	55	60	65	70	75		
<b>TUBE TYPE TIRES MOUNTED ON 5° TAPERED BEAD SEAT RIMS</b>													
6.50-16	C	1270	1390	1500	1610								
7.00-15	C	1350	1480	1610	1720								
7.00-15	D	1350	1480	1610	1720	1830	1940	<u>2040</u>					
7.00-16	C	1430	1560	1680	1800								
7.00-16	D	1430	1560	1680	1800	1910	2030	<u>2130</u>					
7.00-18	D	—	—	—	—	1950	2090	<u>2220</u>	2350	2470	<u>2590</u>		
7.50-16	C	1620	1770	1930	2060								
7.50-16	D	1620	1770	1930	2060	2190	2310	<u>2440</u>					
7.50-16	E	1620	1770	1930	2060	2190	2310	<u>2410</u>	2560	2670	<u>2780</u>		
7.50-17	D					2110	2270	<u>2410</u>	2540	2680	<u>2800</u>		
7.00-17	D					1870	2010	<u>2130</u>	2260	2370	<u>2490</u>		
<b>TUBELESS TIRES MOUNTED ON 15° TAPERED BEAD SEAT DROP CENTER RIMS</b>													
7.00-15	D	1640	1790	1940	2075	2205	2335	<u>2455</u>					
8-19.5	D	—	—	—	—	2110	2270	<u>2410</u>	2540	2680	<u>2800</u>		
8-19.5	E	—	—	—	—	2110	2270	<u>2410</u>	2540	2680	<u>2800*</u>		

**TIRES USED AS DUALS**

Tire Size	Load Range	Tire Load Limits at Various Inflation Pressures											
		30	35	40	45	50	55	60	65	70	75		
<b>TUBE TYPE TIRES MOUNTED ON 5° TAPERED BEAD SEAT RIMS</b>													
6.50-16	C	1120	1225	1320	1420								
7.00-16	C	1260	1365	1475	1580								
7.00-16	D	1260	1365	1475	1580	1685	1780	<u>1870</u>					
7.00-18	D	—	—	1710	1830	1950	2060	<u>2170</u>	<u>2270</u>				
7.50-16	C	1430	1565	1690	1815								
7.50-16	D	1430	1565	1690	1815	1930	2040	<u>2140</u>					
7.50-16	E	1430	1565	1690	1815	1930	2040	<u>2140</u>	2245	2345	<u>2440</u>		
8.00-16.5	E	1195	1310	1415	1520	1620	1710	<u>1800</u>	1885	1970	<u>2050</u>		
<b>TUBELESS TIRES MOUNTED ON 15° TAPERED BEAD SEAT DROP CENTER RIMS</b>													
8.00-17.5	D	1445	1575	1700	1820	1935	2050	<u>2155</u>					
8.00-19.5	D	—	—	1850	1990	2110	2230	<u>2350</u>	<u>2460</u>				
8.00-19.5	E	—	—	1850	1990	2110	2230	<u>2350</u>	<u>2460</u>	2570	<u>2680(†)</u>		

(†) 2780 lbs. at 80 lbs. pressure.

**WIDE BASE TUBELESS TIRES USED AS SINGLES**

Tire Size	Load Range	Tire Load Limits at Various Inflation Pressures											
		30	35	40	45	50	55	60	65	70	75		
7.00-14LT	C	6	1030	1130	1220	1310							
7.00-14LT	D	8	1030	1130	1220	1310	1390	1470	<u>1550</u>				
6.70-15LT	C	6	1210	1320	1430	<u>1520</u>							
8.00-16.5	C	1360	1490	1610	1730								
8.00-16.5	D	1360	1490	1610	1730	1840	1945	<u>2045</u>					
8.00-16.5	E	1360	1490	1610	1730	1840	1945	<u>2045</u>	2145	2240	<u>2330</u>		
8.75-16.5	C	1570	1720	1850	1990								
8.75-16.5	D	1570	1720	1850	1990	2110	2240	<u>2350</u>					
8.75-16.5	E	1570	1720	1850	1990	2110	2240	<u>2350</u>	2470	2570	<u>2680</u>		
9.50-16.5	D	1860	2030	2190	2350	2500	2650	<u>2780</u>					
9.50-16.5	E	1860	2030	2190	2350	2500	2650	<u>2780</u>	2920	3050	<u>3170</u>		
10.00-16.5	C	1840	2010	2170	2330								

(Refer to Tire Load and Inflation Pressure Notes)

## TIRE LOAD AND INFLATION PRESSURE TIRES FOR LIGHT TRUCKS USED IN HIGHWAY SERVICE (Cont'd)

### WIDE BASE TUBELESS TIRES USED AS DUALS

Tire Size	Load Range	Tire Load Limits at Various Inflation Pressures									
		30	35	40	45	50	55	60	65	70	75
8.00-16.5	C	1195	1310	1415	1520						
8.00-16.5	D	1195	1310	1415	1520	1620	1710	1800			
8.75-16.5	C	1380	1515	1630	1750						
8.75-16.5	D	1380	1515	1630	1750	1855	1970	2070			
8.75-16.5	E	1380	1515	1630	1750	1855	1970	2070	2175	2260	2360

#### Tire Load and Inflation Pressure Notes

1. Tire inflation pressure may increase as much as 6 pounds per square inch (psi) when hot.
2. For continuous high speed operation, (over 75 mph) with passenger car type tires increase tire inflation pressure 4 pounds per square inch over the recommended pressures up to a maximum of 32 pounds per square inch cold for load range B tires, or 36 pounds per square inch cold for load range C tires. Sustained speeds above 75 mph are not recommended when the 4 pounds per square inch adjustment would require pressures greater than the maximum stated above.
3. For sustained high speed driving over 65 MPH, with truck type tires cold inflation pressures must be increased 10 PSI above those specified in the above table for the load being carried. For special operating conditions . . . such as campers or other high center of gravity loading vehicles . . . cold inflation pressures may be increased up to 10 PSI. The total increase in cold inflation pressures shall not exceed 10 PSI above those specified in the above table for the load being carried.
4. Cold tire inflation pressure: after vehicle has been inoperative for 3 hours or more, or driven less than 1 mile. Hot tire inflation pressure: after vehicle has been driven 10 miles or at speeds of more than 60 miles per hour.
5. Loads should be distributed as evenly as possible in the cargo area.
6. Vehicles with luggage racks do not have a vehicle load limit greater than specified.
7. When towing trailers, the additional load on the axle induced by the trailer tongue load must not cause the axle load to exceed the limits stamped on the GVW plate. Tire inflation pressures must be adjusted accordingly.
8. Maximum load must not exceed the maximum tire load limit as indicated by the underscoring in the table. Minimum recommended cold inflation pressures for various loads must conform to the table.

## SERVICE OPERATIONS

**CAUTION:** Servicing of tires mounted on multi-piece rims requires proper tools, safety equipment and specialized training. Severe injuries can result from improper servicing techniques. It is recommended that tires on multi-piece rims be serviced only by competent personnel with proper equipment or by competent truck tire repair shops.

### CORRECTING IRREGULAR TIRE WEAR

#### Heel and Toe Wear

This is a saw-toothed effect where one end of each tread block is worn more than the other. The end that wears is the one that first grips the road when the brakes are applied.

Heel and toe wear is less noticeable on rear tires than on front tires, because the propelling action of the rear wheels creates a force which tends to wear the opposite end of the tread blocks. The two forces, propelling and braking, make for more even wear of the rear tires, whereas only the braking forces act on the front wheels, and the saw-tooth effect is more noticeable.

A certain amount of heel and toe wear is normal.

Excessive wear is usually due to high speed driving and excessive use of brakes. The best remedy, in addition to cautioning the owner on his driving habits, is to interchange tires regularly.

#### Side Wear

This may be caused by incorrect wheel camber, underinflation, high cambered roads or by taking corners at too high a rate of speed. The first two causes are the most common. Camber wear can be readily identified because it occurs only on one side of the treads, whereas underinflation causes wear on both sides. Camber wear requires correction of the camber first and then interchanging tires. There is, of course, no correction for high cambered roads. Cornering wear is discussed further on.

#### Misalignment Wear

This is wear due to excessive toe-in or toe-out. In either case, tires will revolve with a side motion and scrape the tread rubber off. If misalignment is severe, the rubber will be scraped off of both tires; if slight, only one will be affected. The scraping action against the face of the tire causes a small feather edge of rubber to appear on one side of the tread and this feather edge is certain

indication of misalignment. The remedy is readjusting toe-in, or rechecking the entire front end alignment if necessary.

### Uneven Wear

Uneven or spotty wear is due to such irregularities as unequal caster or camber, bent front suspension parts, out-of-balance wheels, brake drums out of round, brakes out of adjustment or other mechanical conditions. The remedy in each case consists of locating the mechanical defect and correcting it.

### Cornering Wear

When a truck makes an extremely fast turn, the weight is shifted from an even loading on all wheels to an abnormal load on the tires on the outside of the curve and a very light load on the inside tires, due to centrifugal force. This unequal loading may have two unfavorable results.

**First**, the rear tire on the inside of the curve may be relieved of so much load that it is no longer geared to the road and it slips, grinding off the tread on the inside half of the tire at an excessive rate. This type of tire shows much the same appearance of tread wear as tire wear caused by negative camber.

**Second**, the transfer of weight may also overload the outside tires so much that they are laterally distorted resulting in excessive wear on the outside half of the tire, producing a type of wear like that caused by excessive positive camber.

Cornering wear can be most easily distinguished from abnormal camber wear by the rounding of the outside shoulder or edge of the tire and by the roughening of the tread surface which denotes abrasion.

Cornering wear often produces a fin or raised portion along the inside edge of each row in the tread pattern. In some cases this fin is almost as pronounced as a toe-in fin, and in others, it tapers into a row of tread blocks to such an extent that the tire has a definite "step wear" appearance.

The only remedy for cornering wear is proper instruction of operators. Driving more slowly on curves and turns will avoid grinding rubber off tires. To offset normal cornering wear as much as possible tires should be interchanged at regular intervals.

### Wheel and tire Balancing

It is desirable from the standpoints of tire wear and vehicle ride and handling ease to maintain proper balance of wheel and tire assemblies on all models. This may be accomplished by either of the two types of balancing systems in current use which balance wheels either on the vehicle or off. The "on the vehicle" type, however, is the more desirable in that all rolling components (brake drums, bearings, seals, etc.) are included in the balancing procedure and thereby have any existing unbalance corrected.

### Truck Wheel Balance Weights

All 1974 truck wheels equipped with a tubular side ring (rolled flange rim) on the outboard side of the wheel rims require special design weights to fit. Dynamic balancing can be accomplished through use of these special balance weights which are designed only for installations on the outboard side of these wheels. Conventional weights fit only the inboard side of these wheels.

### Static Balance

Static balance (sometimes called still balance) is the equal distribution of weight of the wheel and tire assembly about the axis of rotation in such a manner that the assembly has no tendency to rotate by itself, regardless of its position. For example: A wheel with a chunk of dirt on the rim will always rotate by itself until the heavy side is at the bottom. Any wheel with a heavy side like this is statically out of balance. Static unbalance of a wheel causes a hopping or pounding action (up and down) which frequently leads to wheel "flutter" and quite often to wheel "tramp".

### Dynamic Balance

Dynamic balance (sometimes called running balance) means that the wheel must be in static balance, and also run smoothly at all speeds.

To insure successful, accurate balancing, the following precautions must be observed:

- Wheel and tire must be clean and free from all foreign matter.
- The tires should be in good condition and properly mounted with the balance mark on the tire, if any, lined up with the valve.
- Bent wheels that have runout over 1/16" should be replaced.
- Inspect tire and wheel assembly to determine if an eccentric or out-of-round condition exists. Note that this condition, if severe, cannot be "balanced out." An assembly which has an out-of-round condition exceeding 3/16" on tire sizes through 19.5" is not suitable for use on the front of the vehicle. Its use on the rear should be governed by its general condition and whether the roundness defect seriously detracts from overall ride quality.
- When balancing wheels and tires, it is recommended that the instructions covering the operation of the wheel balancer being used be closely followed.

## WHEEL REMOVAL AND INSTALLATION

### Jacking Instructions

Place vehicle jack supplied or recommended as follows: **to raise a rear wheel**, place jack under axle housing; **to raise front wheel of C, G, P models**, place jack under

## 10-8 WHEELS AND TIRES

lower control arm pivot; to raise front wheel of K models, place jack under front axle near spring seat.

### Dual and Single Wheels

When installing the tire and wheel on the vehicle, the following procedure should be followed:

After wheel nuts are put on loosely, turn the wheel until one nut is at the top of the bolt circle; tighten the nut just snug. Snug up the remaining nuts criss-cross to minimize runout, then tighten the nuts to the recommended torque alternately and evenly to avoid excessive runout.

When installing wheels on vehicles with dual rear wheels:

1. Install inner and outer wheel and clamp ring on rear, or wheel and clamp ring on front (be sure pins on clamp ring face outboard).
2. Install and snug nuts finger tight.
3. Torque nuts to specified torque in sequence shown in Figure 3.

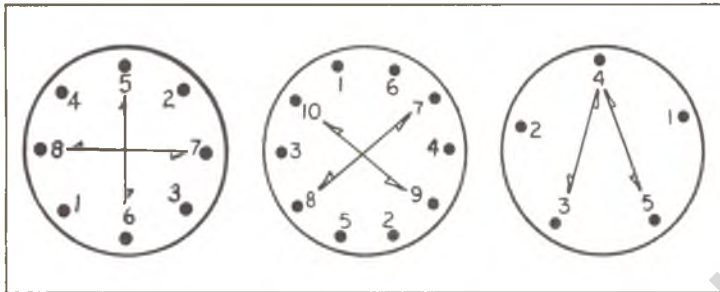

Fig. 3—Wheel Nut Tightening Sequence

Lateral runout should not exceed 1/8" on front wheel or 3/16" on rear wheel.

### Matching Side and Lock Rings

Side and lock rings of different rim types are **not interchangeable**. Some may appear to be, but they do not fit properly on the rim base. Serious accidents have resulted from the use of mismatched rings. Rim base and rings must be matched according to manufacturer, size and type. This information is stamped on each part.

### Installing Synthetic Tubes

**CAUTION:** When tube and flap are not properly lubricated and mounted, they will stretch thin in the tire bead and rim region. This will cause premature failure.

1. Before installing tube in tire, clean inside of casing thoroughly.
2. Insert tube in tire and inflate until it is nearly rounded out.
3. Inspect rim for rust scale and bent flanges—clean rust scale and straighten flanges where necessary.
4. Using a brush or cloth swab, apply a solution of neutral vegetable oil soap to the inside and outside

of tire beads and also to the rim side of the tube. Do not allow soap solution to run down into tire.

5. When mounting tire and tube on a drop center rim, follow the standard procedure. Be sure tire is centered on rim so that beads are out of rim well before inflating. Do not allow tire to hang loosely on wheel while inflating.
6. Center valve and pull it firmly against the rim. Hold in this position and inflate until tire beads are firmly seated on rim against flanges.
7. Completely deflate tire by removing valve core.
8. Reinflate tire to recommended pressure.

## TUBELESS TIRES

Tubeless tires mounted on one piece full drop center rims are standard on some trucks. These tires have a safety inner liner which if punctured, tends to cling to the penetrating object forming a partial seal until the object is removed from the tire.

The mounting and demounting of tubeless truck tires will present no problem when a rubber lubricant, such as Ru-Glyde or equivalent is applied to tire beads and rim flanges. Ru-Glyde or equivalent in addition to materially assisting in mounting and demounting also prevents rusting at the tire sealing area and thus prevents tires from adhering to the wheel.

**CAUTION:** A hammer, or tools with sharp edges, should never be used to demount or mount tubeless tires as damage to rim flange or tire sealing bead may result.

### Inspection for Leaks

1. With wheel assembly removed from vehicle, inflate the tire to recommended operating pressure.
2. Check for leaks at rim bead by placing wheel and tire horizontal and allowing water to stand in groove between rim and tire. Check for large leaks by lowering assembly into water tank or running water over tire.

### Demounting

1. Remove valve core to completely deflate tire. With tire lying flat on floor, loosen beads from rim seats by walking around on tire with heels at points close to rim. With wide side of rim down, apply tire lubricant to top bead. With stops toward rim, insert spoon ends of two tire irons about 10" apart. While standing on tire to hold bead in gutter, pull one tool toward center of rim.
2. Hold one iron in position with foot and pull second iron toward center of rim. Progressively work bead off rim, taking additional bites if necessary.
3. Stand assembly in vertical position. Lubricate second bead. At top of assembly insert straight end of tire iron between bead and back flange of rim at about a 45 degree angle.

4. Turn iron so that it is perpendicular to rim. Pry second bead off.

**Mounting**

All tubeless tires will be mounted as follows:

1. Inspect rim to insure bead seats are clean and smooth. Then place rim on floor with wide side down and lubricate first bead of tire and upper bead seat of rim.
2. Push first bead into well of rim and onto rim as far as possible. Using straight end of tire iron and with stop resting on rim flange, work remaining section of first bead over rim.
3. Hold second bead in well by standing on tire. When necessary, push section of bead into rim well and anchor with vise-grip pliers by pinching pliers on rim flange. Using spoon end of tire iron with stop toward rim, work progressively around bead using small bites until bead slips over flange onto rim base. If necessary, insert second tire iron and lubricate last 6" of bead before completing.
4. Check valve to be certain that hex nut at the valve base is tight. Inflate tire to recommended operating pressure. Check assembly for air leaks.

**TUBE TYPE TIRES**

The 16.0 x 5.50F dual wheel uses a continuous side ring which has two cutouts directly opposite each other and a single tool notch located approximately 45 degrees from one cutout, (fig. 4). The cutouts enable the continuous side ring to be buttoned on to the rim base without deforming either the ring or rim.

**Rim-Tire Replacement**

**Safety Precautions**

- Use only parts free from damage or heavy rust.

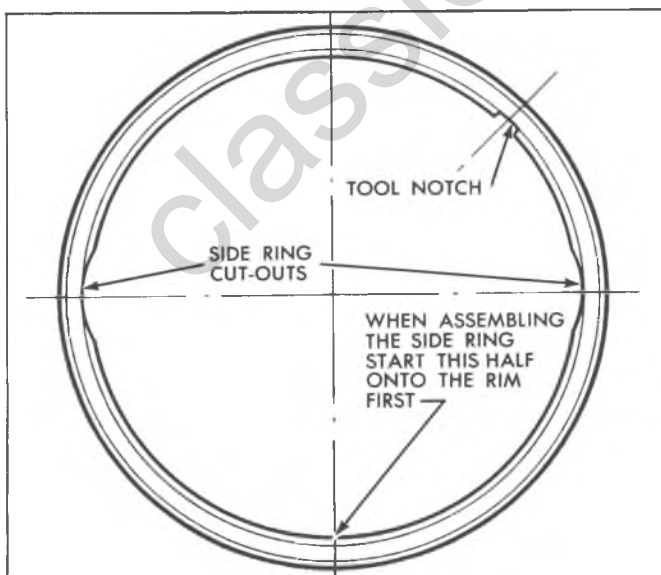

Fig. 4—RHP Continuous Side Ring



Fig. 5—Loosening First Bead

- Insure that side ring is completely seated before inflating tire.
- Inflate tire in safety cage or use clip-on type air chuck so that operator may stand aside during inflation.
- Insure that tire is completely deflated prior to removal of rings.

**Demounting**

1. First remove valve core to completely deflate tire.
2. Place tire and wheel on floor with side ring up.
3. To loosen first bead, drive hooked end of rim tool between tire and rim flange and press downward on bead (fig. 5). Progress around rim, using 2 tools, as shown.



Fig. 6—Removing Ring

## 10-10 WHEELS AND TIRES

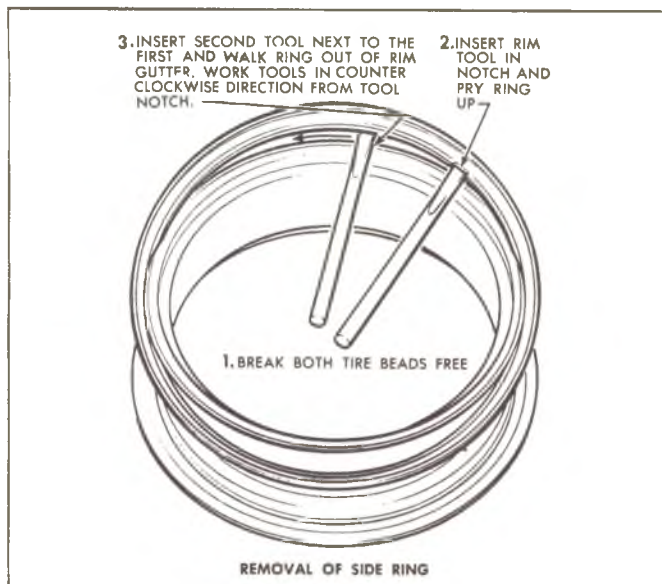

Fig. 7—Removal of Side Ring



Fig. 9—Prying Second Bead From Rim

4. The side ring is ready to demount if it is loose and turns easily in the rim gutter.
5. Locate the tool notch in the side ring and insert the rim tool or a long, husky screwdriver and pry up (fig. 6), making sure the opposite side of the ring is fitting into the rim gutter. Do not bend the ring.
6. Now a second tool can be inserted (see fig. 7) and used with the first to walk the tools in a counterclockwise direction from the tool notch (work toward the cutout that is farthest from the tool notch).
7. When the tools reach the cutout the ring will usually spring off. If necessary, a light tap with the mallet will free the last half of the ring after it has been pried up so both cutouts are visible.

8. Force upper tire bead into well opposite the valve slot and with tire tool pry opposite portion of bead over edge of rim (fig. 8).
9. Turn tire over and by means of rim tools, loosen bead on opposite bead seat. This can be further aided by using foot pressure.
10. Make sure one portion of second bead is still in the rim well, then pry opposite portion of bead over edge of rim (fig. 9). This will free the tire from the rim.

### Mounting

1. Place tire on rim so that valve is in line with valve hole and insert valve through valve hole.



Fig. 8—Prying Bead Over Edge of Rim



Fig. 10—Mounting First Bead



Fig. 11—Applying Second Bead

2. Force first bead down into well of rim just to side of valve with foot.
3. Mount first bead over rim gutter with rim tool progressing from each side of foot to point approximately opposite foot (fig. 10).
4. To apply second bead, start at point opposite valve and press bead toe over rim gutter and into rim well with foot pressure (fig. 11).
5. Mount remainder of bead over rim gutter by means of thin tire tool, being careful not to pinch tube.
6. Place half of side ring in rim gutter and push until the ring is half on and the crescent shaped cutouts straddle the rim gutter per illustration (fig. 12).
7. Insert rim tool or large screwdriver in the tool notch and pull the ring on and down toward the rim gutter.
8. While pulling on the rim tool or screwdriver, hit the side ring a sharp blow with a mallet in the area between the tool notch and the nearest cutout. The second half of the ring will now be started over the rim gutter (fig. 13).
9. Remove the rim tool and continue the mallet blows starting at the tool notch and progress counterclockwise until the entire ring is in the rim gutter.
10. Check to make sure the side ring is properly assembled before inflating the tire. The ring will turn easily on the rim base after it is fully assembled.

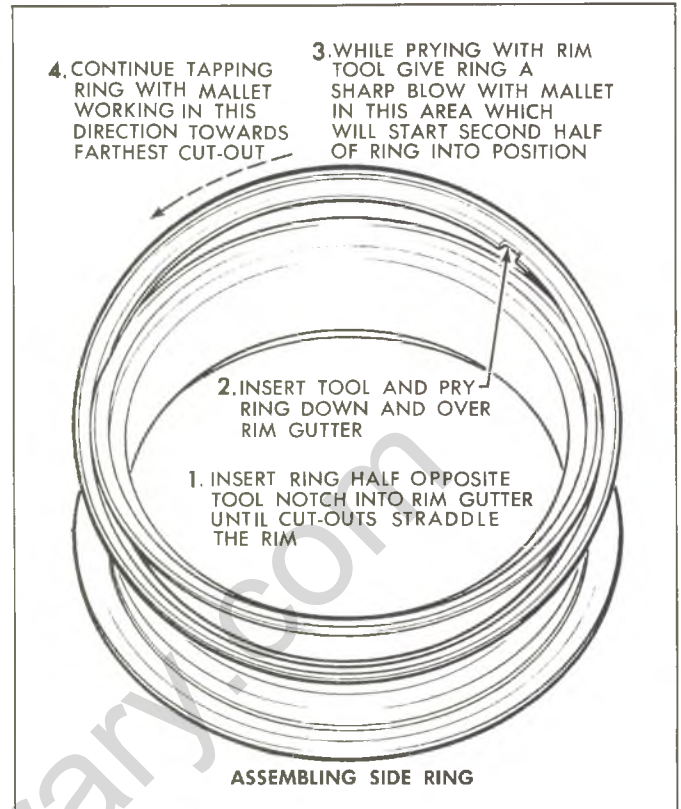

Fig. 12—Assembling Side Ring



Fig. 13—Forcing Ring into Gutter



classiccarylbrary.com

# SECTION 11

## CHASSIS SHEET METAL

### INDEX

General Description .....	11-1	Hood Assembly.....	11-4
Maintenance and Adjustment.....	11-1	Front Sheet Metal - CK Series.....	11-5
Hood Assembly - CK Series.....	11-1	Radiator Support .....	11-6
Hood Hinge Spring Replacement.....	11-1	Front Fender.....	11-7
Hood Hinge.....	11-1	Front Fender and Skirt.....	11-8
Hood Lock Assembly.....	11-2	Front Fender Skirt.....	11-8
Hood Assembly.....	11-3	Running Board.....	11-8
Hood Assembly - G Series.....	11-3	Front Sheet Metal - G Series.....	11-8
Hood Hinge.....	11-3	Sheet Metal Checking.....	11-8
Hood Lock Assembly.....	11-3	Fender Skirt - P Series.....	11-8
Hood Bumper.....	11-4	Wood Grain Applique Installation Procedure .....	11-8

## GENERAL DESCRIPTION

### CK Series

The chassis sheet metal assembly is attached to the frame and body at adjustment points. The front of the assembly is supported by two mounts located at the frame side rails. Fore and aft and side adjustment is allowed by oversize holes at the fender rear attaching point and chassis sheet metal mounts. Special shims at the rear locations allow adjustment of the rear of the assembly. The lower rear edge of the assembly is attached to the body at the rocker panel by bolts on each side. Shims are used at this location to provide in and out adjustment at the rear of the fender. The bolts that retain the sheet metal braces must be torqued to the required torques. If these bolts are loose, the braces will not provide additional support for the sheet metal assembly.

### G Series

The front end sheet metal design does not include the radiator support and fenders as loose items inasmuch that these items are welded together as an integral part of the body.

Front end sheet metal includes the hood assembly, hood hinges, hood lock catch and support, a hood rod assembly which supports the hood, a bolted radiator-upper tie bar, and series designation plates and hoods emblems. Refer to figure 13 for sheet metal checking.

Refer to Section 13 for Radiator and Grille service procedures, Section 14 for Bumpers, and Section 1A for Heater.

## MAINTENANCE AND ADJUSTMENTS

### HOOD ASSEMBLY - CK SERIES

#### Hood Hinge Spring Replacement

For Hinge Spring Replacement, a tool can be made to dimensions as shown in Figure 1.

1. Raise and safely support the hood in full open position.
2. As shown in Figure 2, engage hooked end of tool to spring, then carefully pull forward to engage or disengage spring from hinge assembly.

#### Hood Hinge (Fig. 2)

##### Removal

1. Prop the hood in the extreme open position and

place protective covering over the cowl and fenders.

2. Scribe position of hinge attachment on hood rear reinforcement and remove two bolts.
3. Remove hood hinge spring as described above.
4. Scribe position of hinge attachment on fender assembly and remove bolts.
5. Remove hinge.

##### Installation

1. Install hinge assembly to fender and align within scribe marks. Install bolts.
2. Install hood hinge spring.

## 11-2 CHASSIS SHEET METAL

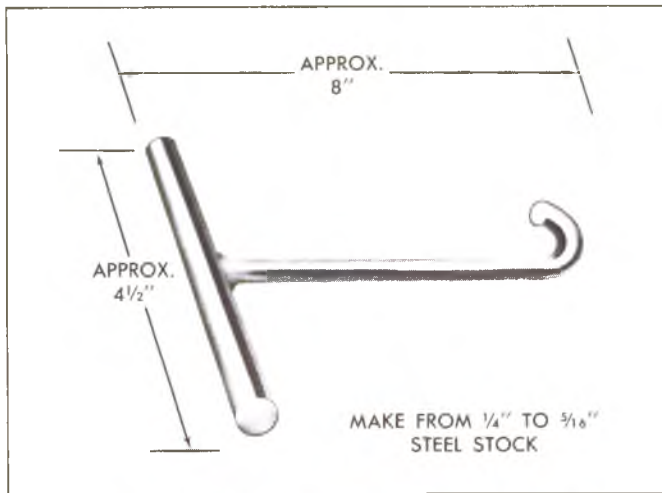

Fig. 1—Hood Hinge Spring Remover/Installer

3. Install bolts and align hood. See Hood Alignment in this section.

### Hood Lock Assembly

A bolt-type hood lock is used as shown in Figure 3. The lock bolt, located on the hood dovetails with the mounted striker plate, preventing upward or downward movement of the hood while the vehicle is in motion. Integral with the striker plate is the combination lock release lever and safety catch.

#### Replacement

1. Open hood and remove the four bolts holding the combination lock support and lock bolt.

NOTE: If original hood lock assembly is to be replaced, scribe a line around lock for alignment on installation.

2. Place hood lock assembly in position.
3. Adjust as outlined under Adjustments.

#### Adjustment (Fig. 4)

1. Loosen lock nut on lock bolt and adjust lock bolt approximately 2 7/16 inches from bottom of lock bolt to bottom of support.
2. Adjust tightness of support screws so they are just snug enough to hold support in position.
3. Adjust support fore and aft until nubble enters center of elongated guide. Bending nubble to accomplish this adjustment may seriously effect lock operation and safety latch engagement and is, therefore, not recommended.
4. Tighten screws to 140 pound inches.
5. Adjust lock bolt to obtain a secure hood closure and reasonable lock release effort.

### Hood Bumper Adjustment

Hood Bumpers must be adjusted until hood and fender line up flush at front corner. Adjust hood lock bolt to

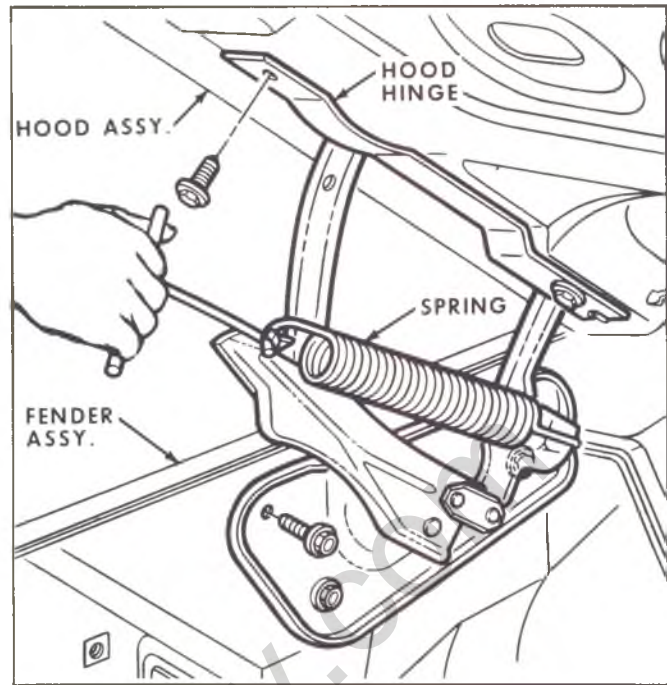

Fig. 2—Hood Hinge and Spring—CK Series

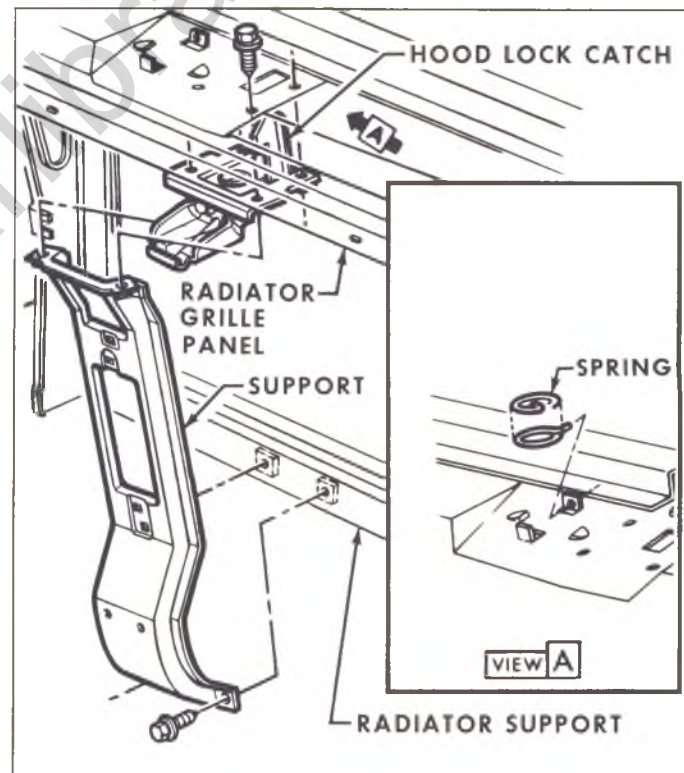

Fig. 3—Hood Lock Catch and Support—CK Series

obtain a minimum load of 45 pounds to a maximum load of 55 pounds on each bumper after hood is firmly slammed.

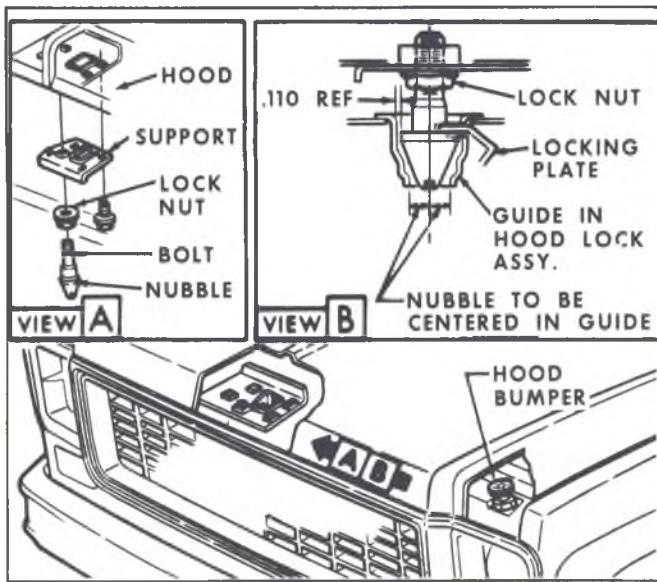

Fig. 4—Hood Lock Bolt and Bumper—CK Series

## Hood Assembly

### Removal

1. Open hood and prop in full open position.  
NOTE: If hood is to be reinstalled and present alignment is satisfactory, mark each hinge in relation to hood, to assure original alignment.
2. Remove two (2) cap screws which attach each hinge to hood; then with a helper remove hood from vehicle.

### Installation

1. If original hood is to be installed, position hood to hinges and install four cap screws snug which attach hinges to hood.  
NOTE: If a new hood is to be installed, perform procedures as outlined under Alignment, directly below.
2. Shift hood on hinges to location marks made before removal of hood, then tighten attaching cap screws at hinges firmly. Close hood and check fit. If necessary to align hood perform procedure as outlined under "Alignment" which follows.

### Alignment (Fig. 2)

1. Loosen hood hinge bolts. Note that rear most bolt hole in hinge is slotted to allow hood trailing edge to move up and down.
2. Adjust hood rear bumper bolt so that bumper is flush with fender. Nut must be threaded completely onto bolt before torquing to maintain design height.

3. Perform hood lock adjustment as outlined in this section if necessary.

## Hood Assembly - G Series

The alignment of the hood is controlled by the position of the hood hinges and the height of the two bumpers located one at each side of the radiator support. The adjustment at the hood lock must be made after the hinges and bumpers are properly adjusted (refer to Hood Lock Adjustment fig. 6). To align the hood and lock proceed as follows:

### Hood Hinge (Fig. 5)

The body mounted portion of the hood hinges are slotted to provide up and down movement. The hood mounted end is slotted to provide forward and rearward movement.

Hood support rod assembly must operate freely without binding in assembled position.

### Hood Lock Assembly

A bolt-type hood lock is used as shown in Figure 6. The lock bolt, located on the hood, dovetails with the mounted striker plate, preventing upward or downward movement of the hood while the vehicle is in motion. Integral with the striker plate is the combination lock release lever and safety catch.

1. Scribe a line around the entire hinge plate to be repositioned.
2. Loosen the appropriate screws and shift the position of the hood into correct alignment using the scribe marks to check amount of movement. Check alignment by tightening screws and closing the hood.

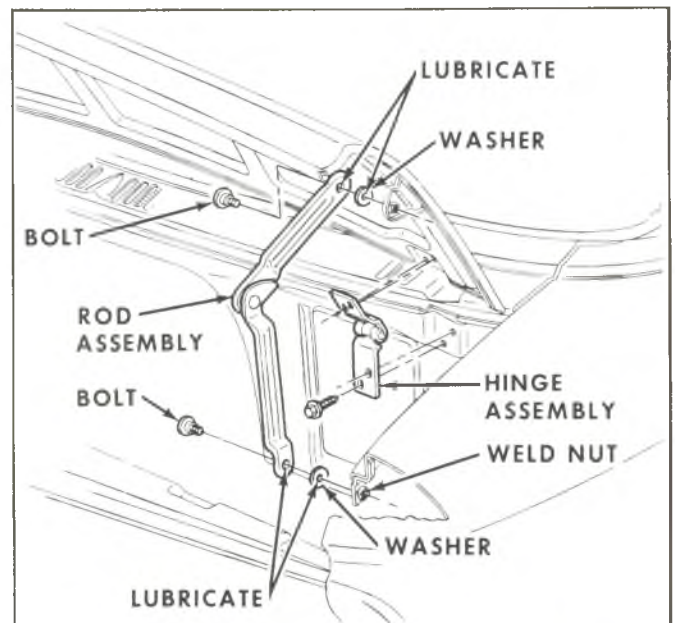

Fig. 5—Hood Hinge and Rod Assembly—G Series

## 11-4 CHASSIS SHEET METAL

### Replacement

1. Open hood and remove the four bolts holding the combination lock catch and lock bolt.

NOTE: If original hood lock assembly is to be replaced, scribe a line around lock for alignment on installation.

2. Place hood lock assembly in position.
3. Adjust as outlined under Adjustments.

### Adjustment

**CAUTION:** Hood lock assembly to be adjusted fore and aft until hood lock bolt enters center of elongated guide. Bending bolt to accomplish this adjustment may seriously effect lock operation and safety catch engagement and is, therefore not recommended.

1. Adjust lock bolt as shown in Figure 7.
2. Open hood and adjust tightness of catch assembly so that it is just "snug" enough to hold lock bolt in position.

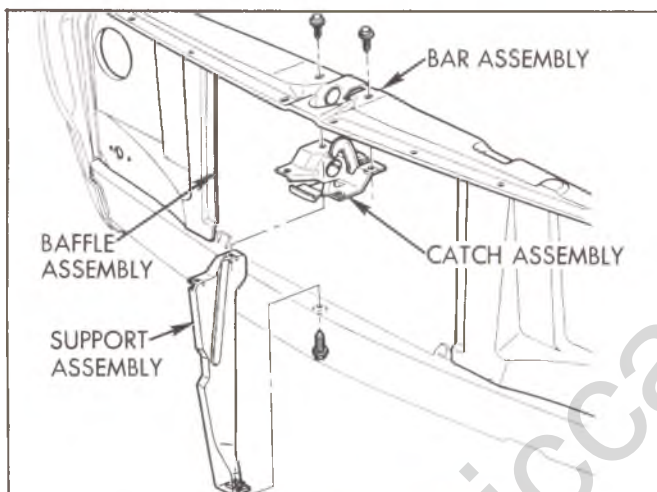

Fig. 6—Hood Lock Catch Assembly—G Series

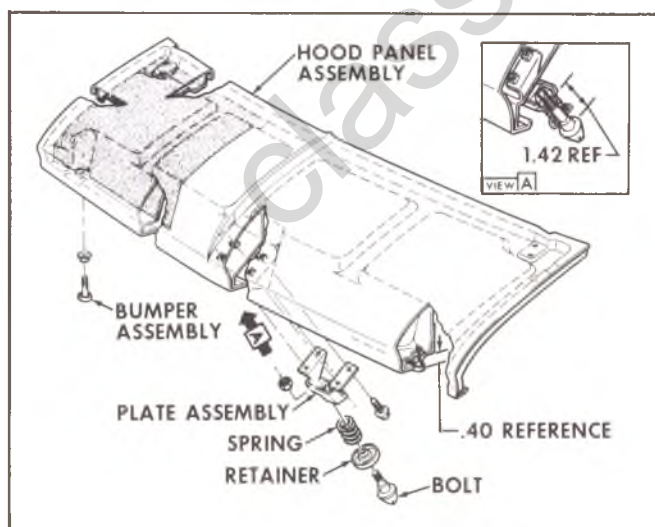

Fig. 7—Hood, Bumpers and Latch—G Series

3. Close hood in a normal manner.
4. Raise hood again; lock bolt assembly will have shifted to operating position. Tighten bolts fully. Further adjustment may be made at lock bolt support, if necessary.
5. Adjust lock bolt to obtain a secure hood closure and reasonable lock release effort.

### Hood Bumper (Fig. 7)

Adjust hood bumpers so that hood top surface is flush with the fender and grille top surfaces. Refer to Figure 13 for correct sheet metal adjustment dimensions.

### Hood Assembly (Fig. 7)

#### Removal

1. Lay a fender cover along cowl top to prevent hood from scratching painted surfaces.
2. Open hood and prop in full open position.  
NOTE: If hood is to be reinstalled and present alignment is satisfactory, mark each hinge in relation to hood, to assure original alignment.
3. Remove rod assembly (see fig. 5).
4. Remove two cap screws which attach each hinge to hood; then with a helper remove hood from vehicle.

#### Installation

1. If original hood is to be installed, position hood to hinges with helper and install four cap screws snug which attach hinges to hood.
2. Install rod assembly.  
NOTE: If a new hood is to be installed, perform procedures as outlined under Alignment, directly below.
3. Shift hood on hinges to location marks made before removal of hood, then tighten attaching cap screws at hinges firmly. Close hood and check fit. If necessary to align hood perform procedure as outlined under "Alignment" which follows.

#### Alignment

1. Loosen hood hinge bolts. Note that rear bolt holes in hinge is slotted to allow hood trailing edge to move up and down.
2. Adjust hood bumpers so that hood and adjacent surfaces are flush.
3. Perform hood lock adjustment as outlined in this section if necessary.

NOTE: Hood Lock Assembly to be adjusted fore and aft until nubble (part of Hood Lock Bolt Support Assembly) enters center of elongated guide (Socket). Bending nubble to accomplish this adjustment may seriously effect lock operation and safety catch engagement and is, therefore, **NOT RECOMMENDED**.

## FRONT SHEET METAL ASSEMBLY-CK SERIES

Removal of entire front sheet metal assembly including radiator involves disassembly of mounts, disconnecting radiator hoses and removal of front bumper. Vehicles equipped with air conditioning and/or power steering will require special handling.

Refer to appropriate sections of this manual for instructions.

Shims which are found at various locations should be recorded to ease installation of sheet metal assembly.

Refer to Figure 8 for sheet metal clearance.

### Removal

1. Drain radiator and remove radiator hoses. Disconnect oil cooler lines if so equipped.
2. Disconnect wire connectors at the dash and toe panel and wire connector to horn and voltage regulator.
3. Disconnect battery and generator wires.

4. Remove front bumper bolts and remove bumper.
5. Remove bolts attaching fender upper edge to cowl door frame.
6. Remove fan shroud.
7. Working from underneath rear of fender, remove attachment from each fender at the hinge pillar.
8. Remove bolt from each radiator support mounting.
9. Remove bolts at each fender skirt to cab underbody (fig. 9).
10. With a helper, remove front sheet metal assembly, with radiator, battery, horn and voltage regulator attached.

### Installation

1. With a helper place sheet metal assembly in position.

NOTE: Install all bolts loosely to facilitate aligning after complete installation.

2. Install fender bolts at cowl.

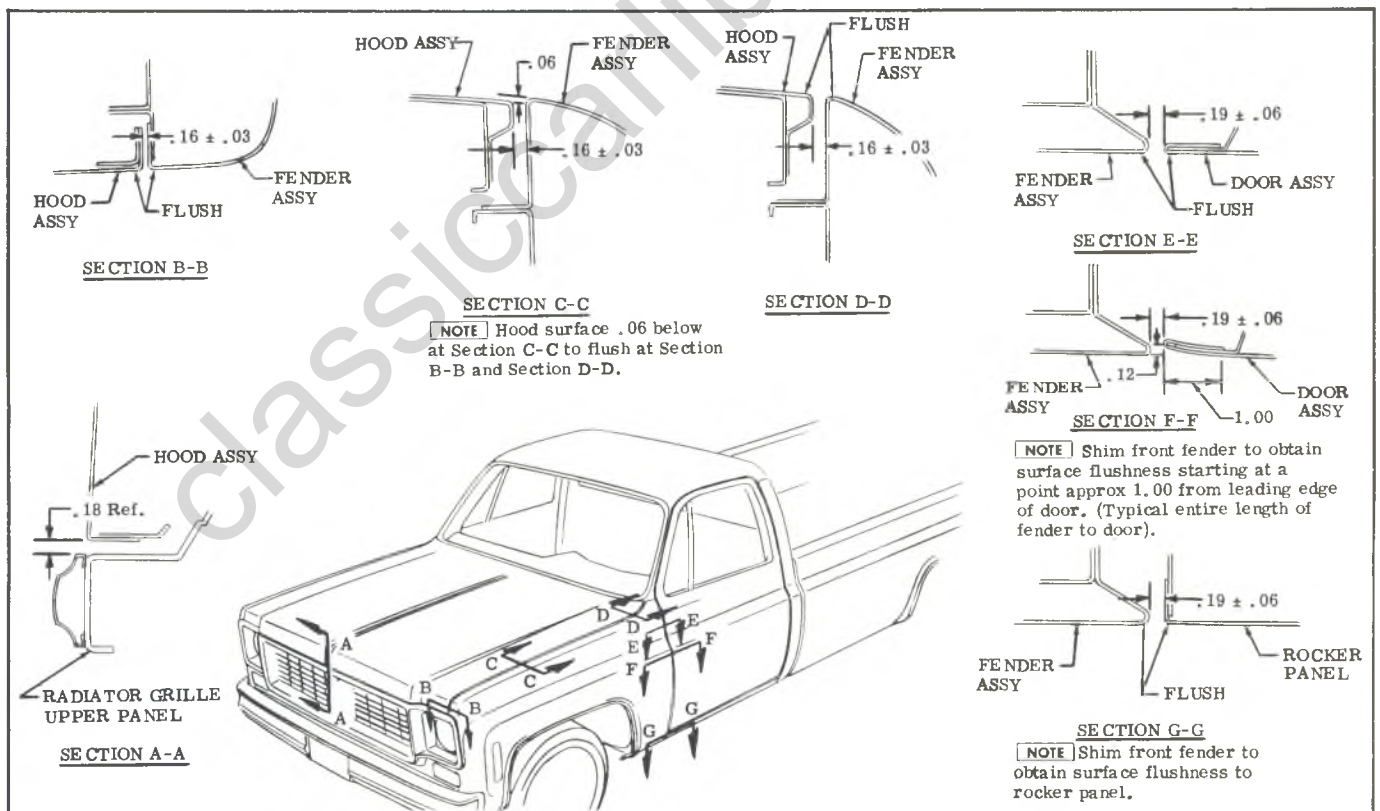

Fig. 8—Sheet Metal Clearance—CK Series

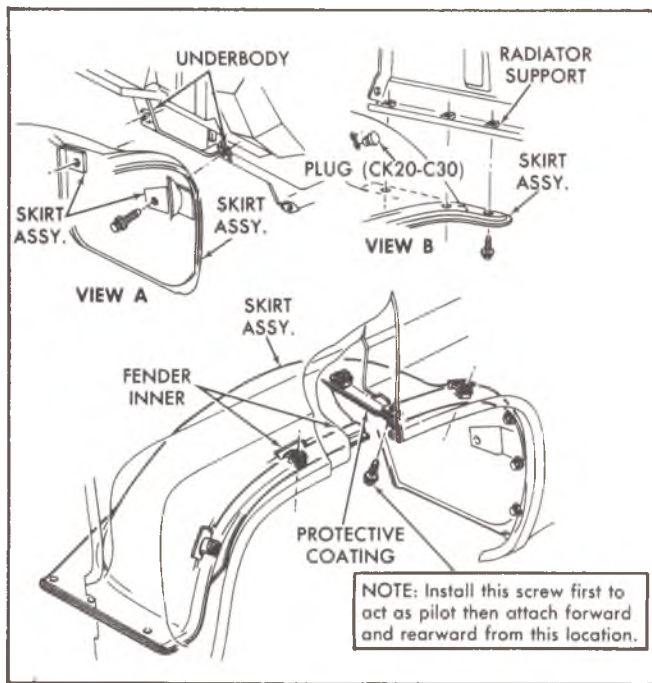

Fig. 9—Fender Skirt Assembly—CK Series

3. Install combination bolt and flat washer assembly into each fender reinforcement while inserting shims required between fender reinforcement and body (See Figure 10).
4. Install two bolts and shims required at each fender rear lower edge to hinge pillar.
5. Install bolt in each fender skirt to underbody.

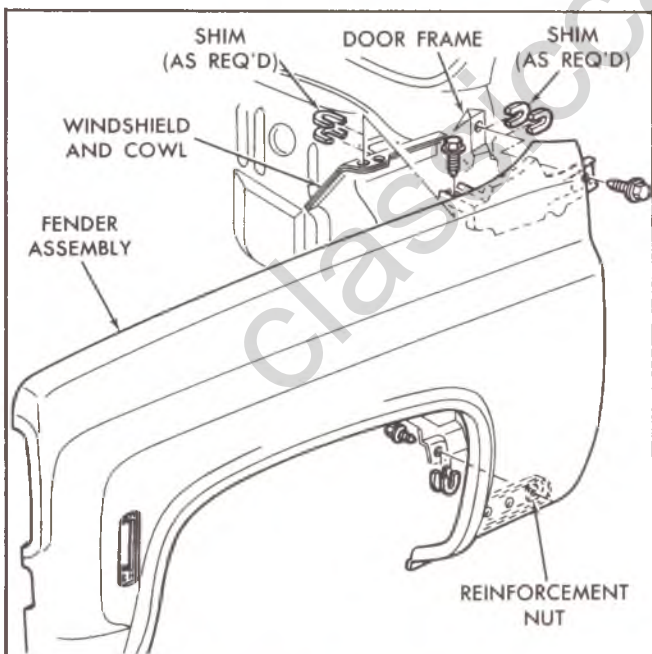

Fig. 10—Front Fender Assembly—CK Series

6. Install bolts at steering column skirt reinforcement, final torque 25 ft. lbs.
7. Tighten each radiator support mounting bolt 33 ft. lbs.
8. Torque bolts at fender to cowl 25 ft. lbs.
9. Install front bumper.
10. Connect wire connectors at dash and toe panel. Attach generator and regulator wires.
11. Connect upper and lower radiator hoses. Connect oil cooler lines to the radiator on models so equipped.
12. Connect battery and fill radiator. Start engine and check for leaks.

### Radiator Support

#### Removal

1. Remove hood as described in this section.
2. Drain radiator, saving coolant, loosen attachments and remove radiator and coolant recovery tank.
3. Disconnect and remove battery.
4. Remove battery tray with battery hanger.
5. Remove wiring from radiator support.
6. Disconnect fan shroud and lay back on engine.
7. Remove both head lamp assemblies.
8. Remove grille assembly.
9. Remove upper and lower radiator grille panels. (Fig. 11).
10. Remove screws securing front fenders to radiator support.
11. Remove screws securing fender skirts to radiator support bottom. (Fig. 9).
12. Remove bolt securing center grille support to radiator support.
13. Remove bolts securing hood catch assembly to radiator support.
14. Remove radiator support bolts secured to frame.
15. Tilt radiator support rearward and lift up and off.

#### Installation

1. Rotate radiator support into position and loosely install attachments to frame.
2. Connect center grille support to radiator support.
3. Connect hood latch plate.
4. Connect radiator support brackets to fenders.
5. Connect support to fenders.
6. Connect screws from underside of fender skirts to support bottom.
7. Attach grille upper panel to fenders loosely.
8. Attach grille lower panel to fenders.

9. Tighten radiator support bolts.
  10. Place battery tray in position and fasten to radiator support.
  11. Install radiator coolant recovery tank hoses and shroud.
  12. Connect removed wiring to radiator support.
  13. Install both head lamp assemblies.
  14. Tighten all previously installed bolts and screws.
  15. Install battery and connect leads and wires.
  16. Install grille assembly.
  17. Fill radiator with coolant as specified in Section 13.
  18. Install hood on previously marked outline.
3. Remove screws attaching upper and lower radiator grille panels.
  4. Remove screws attaching fender wheel opening flange to skirt.
  5. Remove skirt to fender bolts, located inboard on underside of skirt.
  6. Remove two (2) screws attaching support bracket to fender.
  7. Remove five (5) screws attaching radiator support to front fender.
  8. Remove bolt and shim attaching trailing edge of fender to hinge pillar.
  9. Remove two bolts and shims at top rear of fender attaching to cowl.

### FRONT FENDER (FIG. 10)

#### Removal

1. Remove hood and hinge assembly.
2. Remove head lamp bezel, wiring and attachments from fender.

#### Installation

To install, reverse the removal procedure using sealing tape between filler panel and fender. Check sheet metal alignment.

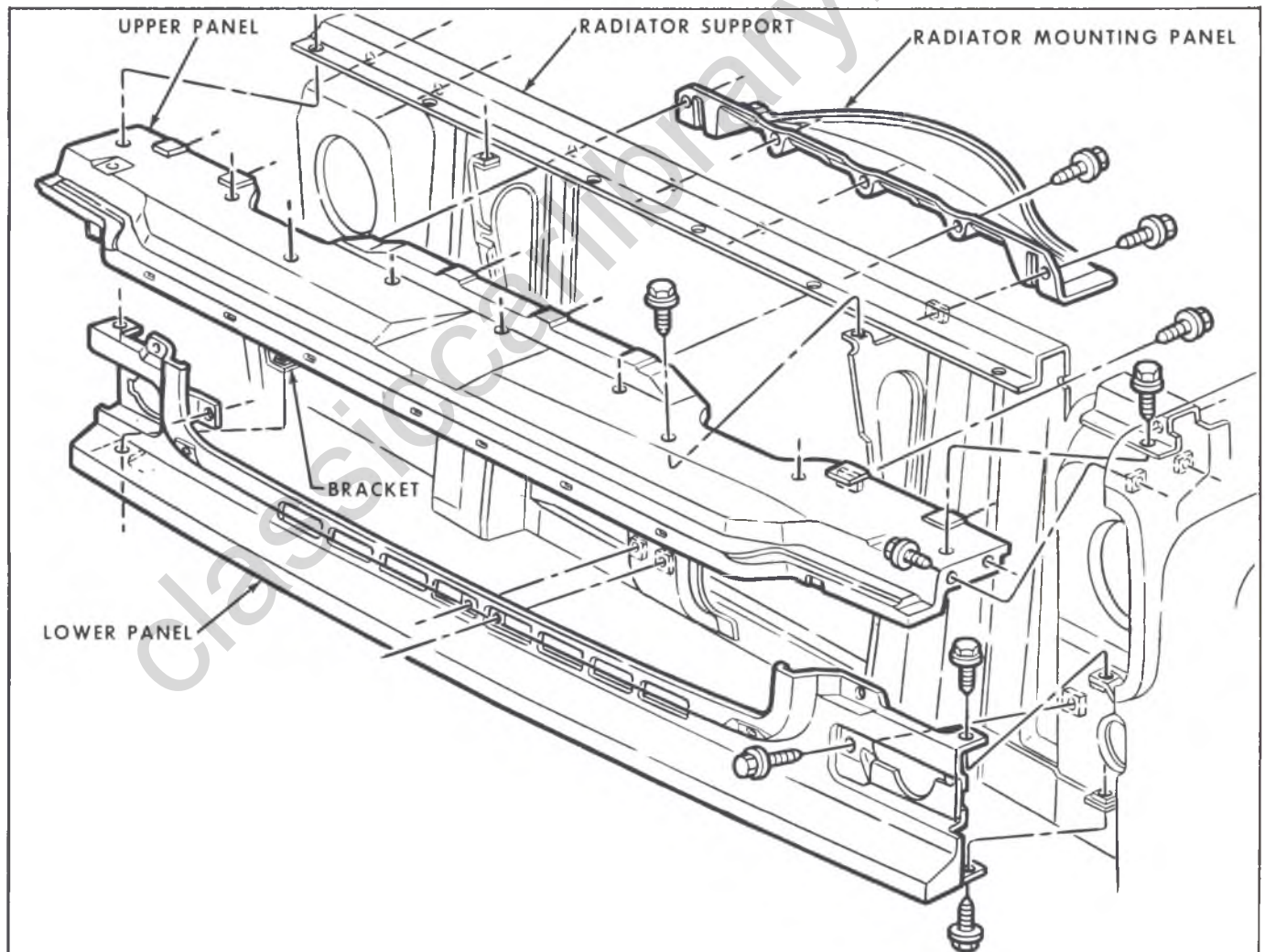

Fig. 11—Radiator Upper and Lower Grille Panels—CK Series



## FRONT FENDER AND SKIRT (FIGS. 9 AND 10)

### Removal

1. Remove hood and hood hinge assembly.
2. Disconnect and remove battery (right side or auxiliary left side).
3. Remove head lamp bezel, wiring and attachments from fender.
4. Remove screws attaching upper and lower radiator grille panels.
5. Remove screws attaching skirt to radiator support.
6. Remove two (2) top rear fender bolts and shims.
7. Remove bolt and shims at bottom of fender.
8. Remove bolt and shim(s) attaching skirt to underbody.
9. Remove two (2) screw attaching support bracket to fender.
10. Remove five (5) screws attaching radiator support to front fender.
11. Lift fender and skirt from truck.

### Installation

Install front fender and skirt assembly in reverse order of removal.

## FRONT FENDER SKIRT

Refer to figure 9 for removal and installation of Front Fender Skirt.

## RUNNING BOARDS

Refer to figure 12 for removal and installation of running boards.

## Front Sheet Metal Assembly - G Series

The front end sheet metal components not covered in this section are covered in the Body Section 1B.

## SHEET METAL CHECKING

Refer to the sheet metal checking illustration figure 13 for proper gaps and hood adjustments.

## Fender Skirt - P Series

Refer to figure 14 for removal and installation of fender skirt, brackets, rear supports and hangers.

## WOOD GRAIN APPLIQUE INSTALLATION PROCEDURE

### General

The wood grain applique (transfer film) is a vinyl material with a pressure sensitive adhesive backing. The

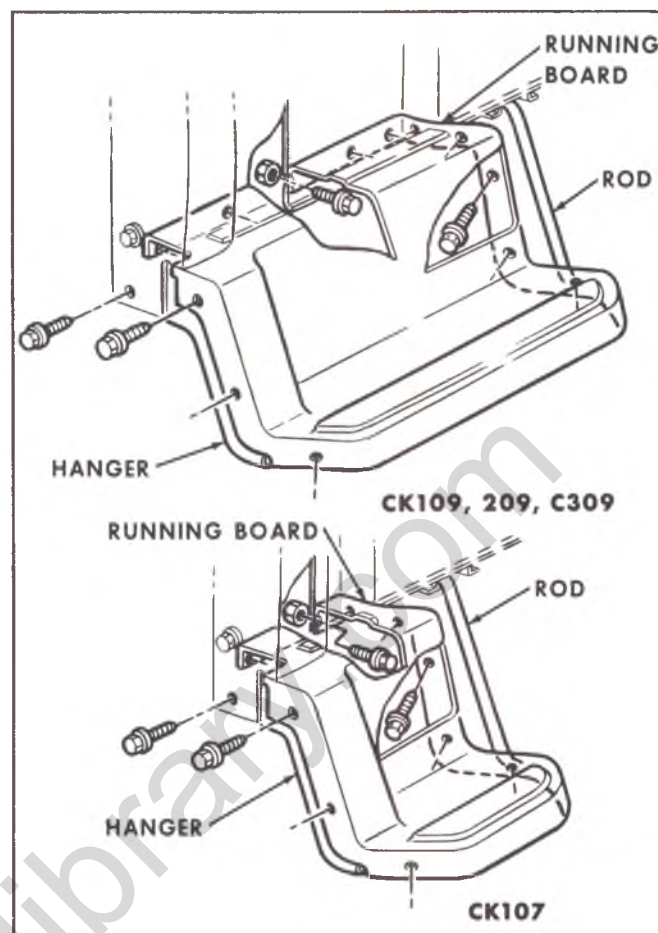

Fig. 12—Running Boards—CK Series

transfers are serviced in pre-cut panels. The transfers are designed with an appealing wood grain pattern and a 50 degree or semi-gloss finish.

Preparation of the surface to which the transfer will be applied is very important. In cases where body metal repair has been made it is necessary to prime and color coat these areas to blend with the undamaged surface. Apply the transfer film to color coated panels only, never to bare metal or primer.

The surface must be free of any imperfections that might high-light through the film. Remove dirt nibs and other foreign material in the paint by light sanding with 600 grit sandpaper.

The temperature of the body must be maintained at a moderate level between approximately 70 and 90 degrees. Too warm a body will cause the wood grain film to stick prematurely while too cool a body will reduce the adhesion of the wood grain film. Cool the body panel with cool water when too warm and heat the body panel with a heat gun or a heat lamp when too cold.

Transfers should not be replaced in temperatures below 65 degrees Fahrenheit. The transfer should not be subjected to temperature greater than 175°F and should

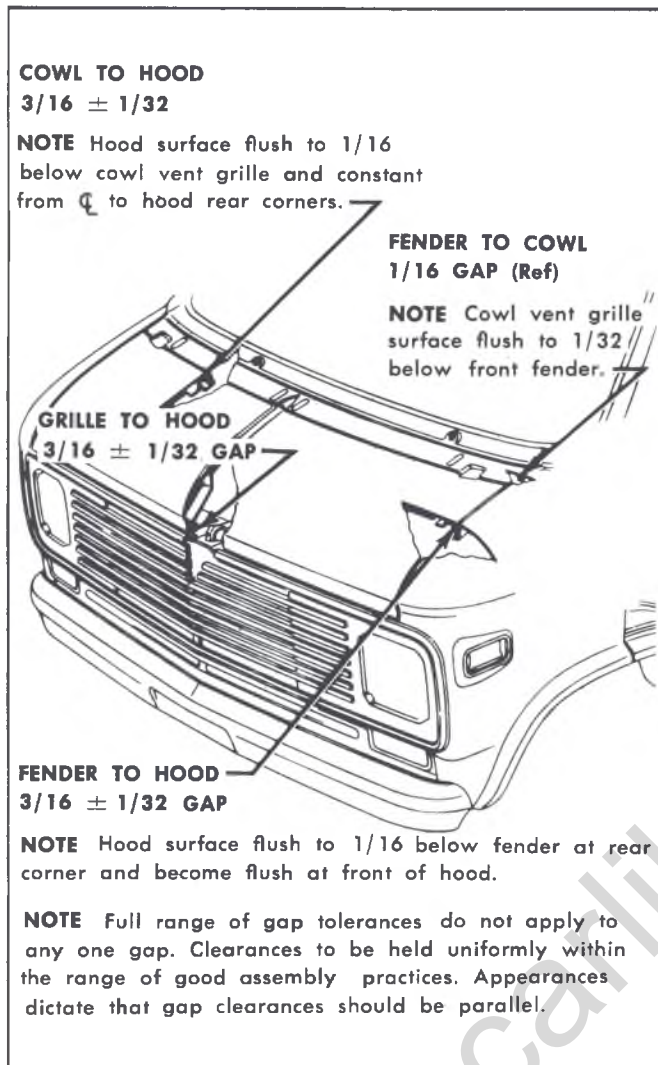

Fig. 13—Front End Sheet Metal Checking—G Series

not be left at or near this temperature for extended periods of time.

Shelf life of the transfer material is 90 days at a temperature not to exceed  $105^{\circ}\text{F}$ .

#### Removal

Remove the moldings from the affected panel. The

transfer film may then be removed by lifting an edge and peeling the material from the painted surface. Exercise care so as not to damage the paint. Application of heat to the transfer and the panel by means of a heat gun or heat lamp will aid in the removal.

#### Installation

1. With a solvent dampened sponge, clean entire surface to be covered with applique.
2. Wipe area dry with a clean cloth.
3. Prior to application of transfer, wet down the complete transfer surface of the fender with a solution of  $1/4$  oz. of neutral detergent cleaner (must not contain oils, perfumes, or bleaches) per gallon of clear water. It is essential that no substitute for this solution be used and that the specified proportions be maintained.
4. While entire area is still wet with solution, remove paper backing from transfer and align upper edge with pierced holes in fender and press on lightly.
5. Start at center of transfer and squeeze outboard from middle to edges removing all air bubbles and wetting solution to assure a satisfactory bond. Use teflon-backed plastic squeegee only.
6. Notch applique at fender rear contour bend areas with scissors. Also notch out front marker lamp.
7. Fold ends of applique over fender flanges using squeegee. Heat the wrap-around area of applique with a heat lamp or gun to approximately  $90^{\circ}\text{F}$  and press with squeegee to secure entire edge surface.
8. If the wrap-around of the transfer has trouble sticking to fender edges, brush vinyl adhesive onto the fender or transfer area. Allow the adhesive to set for one minute then press transfer to fender for adhesion.
9. Inspect transfer installation from critical angle using adequate light reflection to detect any irregularities that may have developed during installation. Remove all air or moisture bubbles by piercing each at an acute angle with a fine pin or needle and by pressing the bubble down.
10. Install previously removed parts and clean up vehicle as required.

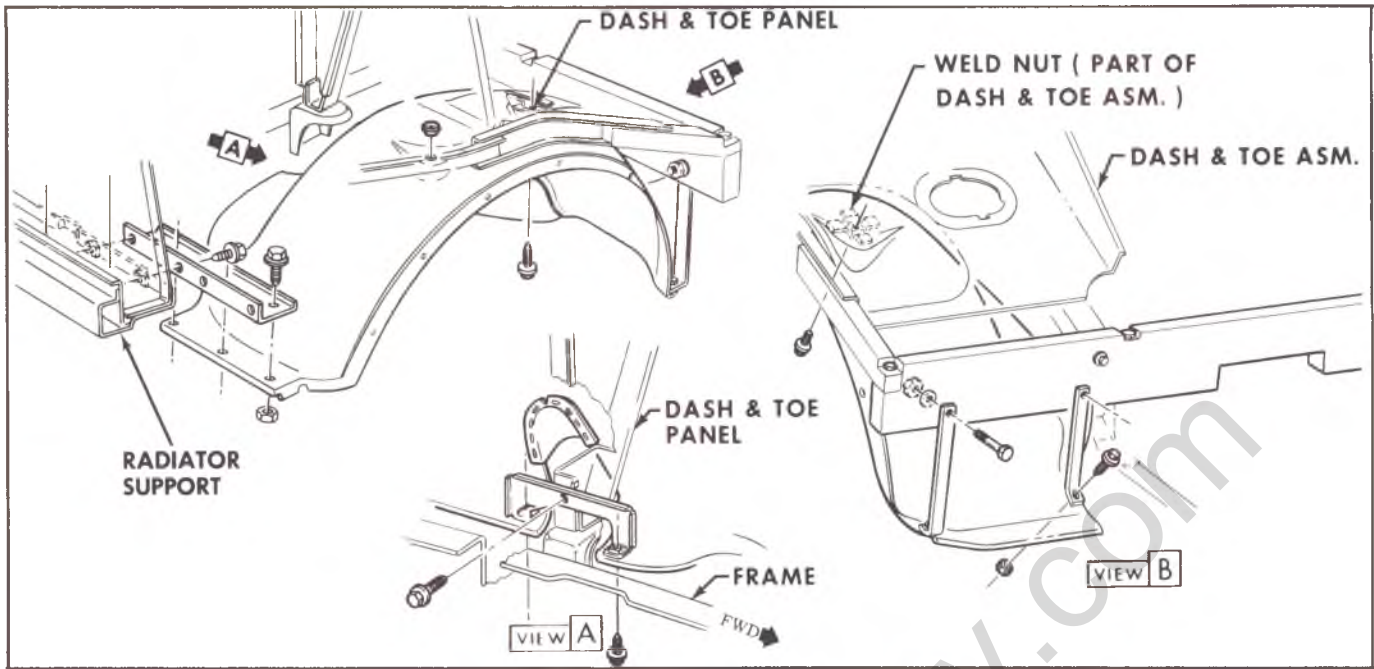

Fig. 14—Fender Skirt, Dash and Toe Pan—P Series

Classiccarlibrary.com

# SECTION 12

## ELECTRICAL—BODY AND CHASSIS

### CONTENTS OF THIS SECTION

Lighting System.....	12-1
Instruments and Gauges .....	12-9
Directional Signals.....	12-15
Windshield Wiper and Washer .....	12-33
Circuit Protection .....	12-43
Diagnosis.....	12-44

## LIGHTING SYSTEM

### INDEX

General Description .....	12-1	Tail, Stop and Backup Lamp Bulbs.....	12-4
Maintenance and Adjustments .....	12-2	Tail, Stop and Backup Lamp Housing.....	12-4
Headlamp Adjustment .....	12-2	Directional Signal Lamps.....	12-4
Component Part Replacement.....	12-2	Clearance and Identification Lamps.....	12-4
Sealed Beam Unit Replacement.....	12-2	Light Switch.....	12-4
Parking Lamp Bulb.....	12-3	Dimmer Switch.....	12-7
Parking Lamp Housing.....	12-3	Stoplamp Switch.....	12-7
Front Side Marker Lamp Bulb and/or Housing.....	12-3	Neutral Start Switch .....	12-7
Rear Side Marker Lamp Bulb and/or Housing..	12-4	Backing Lamp Switch.....	12-9
		Windshield Wiper/Washer Switch.....	12-9

## GENERAL DESCRIPTION

The lighting system includes the main light switch; stop light, dimmer and backing lamp switches; head and parking lamps; stop, tail, side marker, clearance and identification lamps; instrument illumination, directional

signal and indicator lamps and the necessary wiring to complete the various circuits.

A bulkhead fuse panel (fig. 1) provides convenient power

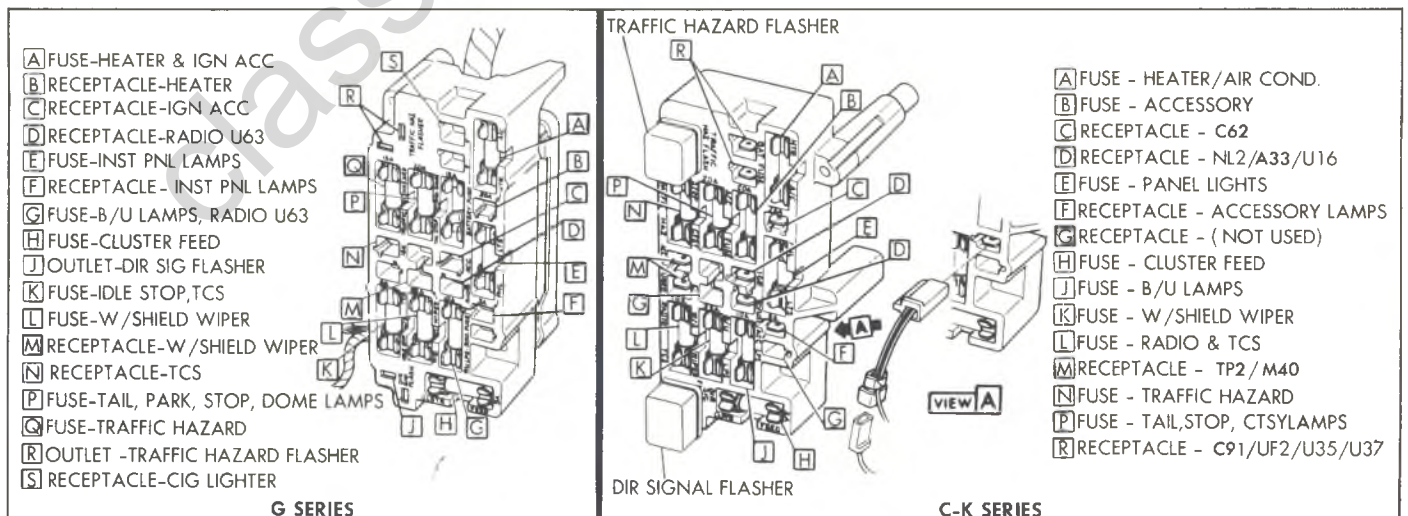

Fig. 1--Fuse Panel

## 12-2 ELECTRICAL - BODY AND CHASSIS

taps and fuse clips for the appropriate circuits. The engine wiring harness and forward lamp harness connectors are bolted to the fuse panel.

All wiring systems not protected by a fuse or circuit breaker incorporate a fusible link which provides increased overload protection. The starting motor circuit is the exception.

Composite wiring diagrams are available in a separate manual. The standardized color code is common to all wiring harnesses. The wire covering color designates a particular circuit usage.

## MAINTENANCE AND ADJUSTMENTS

Maintenance of the lighting units and wiring system consists of an occasional check to see that all wiring connections are tight and clean, that the lighting units are securely mounted to provide good ground and that the headlamps are properly adjusted. Loose or corroded connections may cause a discharged battery, difficult starting, dim lights, and possible damage to the A.C. generator. Wire harnesses must be replaced if insulation becomes burned, cracked, or deteriorated. Whenever it is necessary to splice a wire or repair one that is broken, always use solder to bond the splice. Always use rosin flux solder on electrical connections. Use insulating tape to cover all splices or bare wires.

When replacing wires, it is important that the correct size be used. Never replace a wire with one of a smaller size. Fusible links in the wiring are four gauge sizes smaller than the cable it is designed to protect. The links are marked on the insulation with wire gauge size because of the heavy insulation which makes the link appear a heavier gauge than it actually is.

Each harness and wire must be held securely in place by clips or other holding devices to prevent chafing or wearing away the insulation due to vibration.

By referring to the wiring diagram manual, circuits may be tested for continuous circuit or shorts with a conventional test lamp or low reading volt meter.

### HEADLAMP ADJUSTMENT (Fig. 2)

The headlamps must be properly aimed to obtain maximum road illumination.

The headlamps must be checked for proper aim

whenever a sealed beam unit is replaced and after repairs of the front end sheet metal assembly.

Regardless of the method used for checking headlamp aim, the truck must be at normal weight, that is with gas, oil, water and spare tire. Tires must be inflated to specified pressures.

Some states have special requirements for headlamp aiming adjustment and these requirements must be known and followed.

Horizontal and vertical aiming of each sealed beam is provided by two adjusting screws visible through the bezel which move the mounting ring against the tension of the coil spring (fig. 2).

There is no adjustment for focus since the sealed beam unit is set for focus during manufacturing assembly.

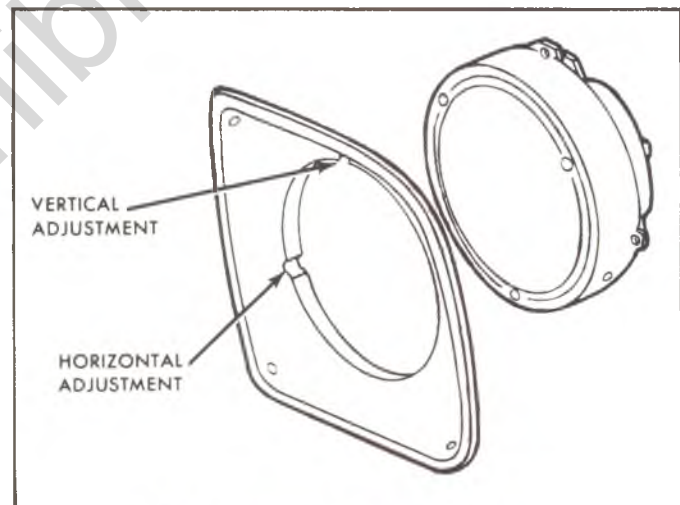

Fig. 2—Headlamp Adjustments (Typical)

## COMPONENT PART REPLACEMENT

### SEALED BEAM UNIT

#### Replacement (Figs. 3 and 4)

1. Remove bezel retaining screws and bezel.
2. Disengage spring from retaining ring.
3. Turn headlamp unit to disengage assembly from headlamp adjusting screws.
4. Disconnect wiring harness connector located at rear of unit in engine compartment.

NOTE: Do not disturb adjusting screw setting.

5. Remove retaining ring and headlamp from mounting ring.
6. Position new sealed beam unit in mounting ring and install retaining ring.

NOTE: The number molded into lens face must be at top.

7. Attach wiring harness connector to unit.

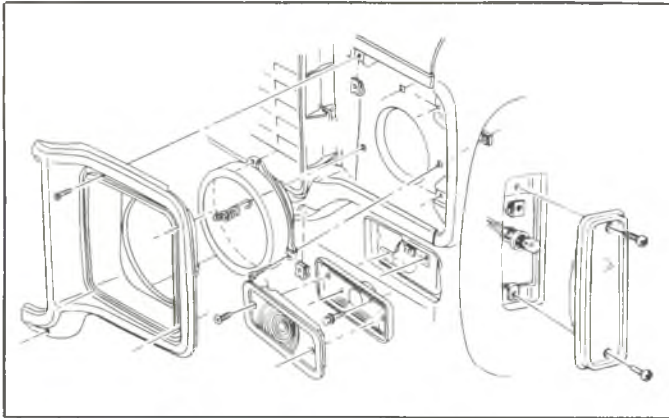

Fig. 3-Front Lighting (C-K Models)

8. Install headlamp assembly in panel opening, twisting slightly to engage mounting ring tabs with adjusting screws.
9. Install retaining ring spring then check operation of unit and install bezel.

### PARKING LAMP BULB

#### Replacement (Figs. 3 and 4)

1. Remove lens retaining screws and remove lens from the housing.
2. Replace the bulb and check lamp operation.
3. Install lens and retaining screws.

### PARKING LAMP HOUSING

#### C-K Models

##### Replacement (Fig. 3)

1. Remove parking lamp lens screws and remove the lens.
2. Remove the lamp housing retaining screws and pull the housing forward.
3. Disconnect the parking lamp wiring harness from the housing by rotating the bulb socket counterclockwise.
4. Connect the wiring harness to the new housing by inserting the bulb socket into the housing and rotating clockwise.
5. Install the bulb if removed during disassembly. Install the lens and retaining screws.

#### G Models

##### Replacement (Fig. 4)

##### Right Side

1. Remove both headlamp bezels.
2. Remove both parking lamp lens.
3. Remove grille.

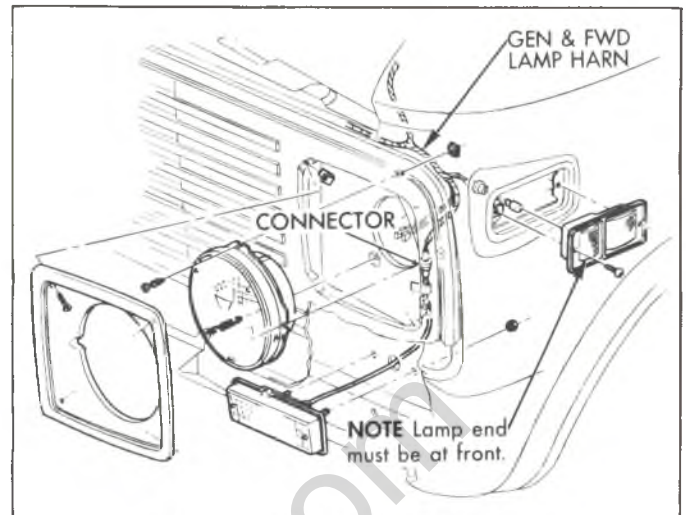

Fig. 4-Front Lighting (G Models)

4. Remove battery and battery box.
5. Disconnect wiring harness at connector.
6. Remove housing stud nuts and remove housing with pigtail.
7. To install, reverse removal steps.

##### Left Side

1. Remove two screws and parking lamp lens.
2. Disconnect wiring harness at connector.
3. Remove housing stud nuts and remove housing with pigtail.
4. To install, reverse removal steps.

### FRONT SIDE MARKER LAMP BULB AND/OR HOUSING

#### All Models

##### Replacement

**NOTE:** For housing replacement follow procedure for the right side bulb replacement below.

1. **Left Side** - Raise hood.

**Right Side** - Remove lamp assembly retaining screws and pull outward on assembly.

2. Twist wiring harness socket 90° counterclockwise and remove harness and bulb from housing.
3. Replace bulb and check lamp operation.
4. Insert bulb into housing, press in on harness socket and twist 90° clockwise. Check that socket is securely attached.
5. **Left Side** - Lower hood.

**Right Side** - Install housing in opening and install retaining screws.

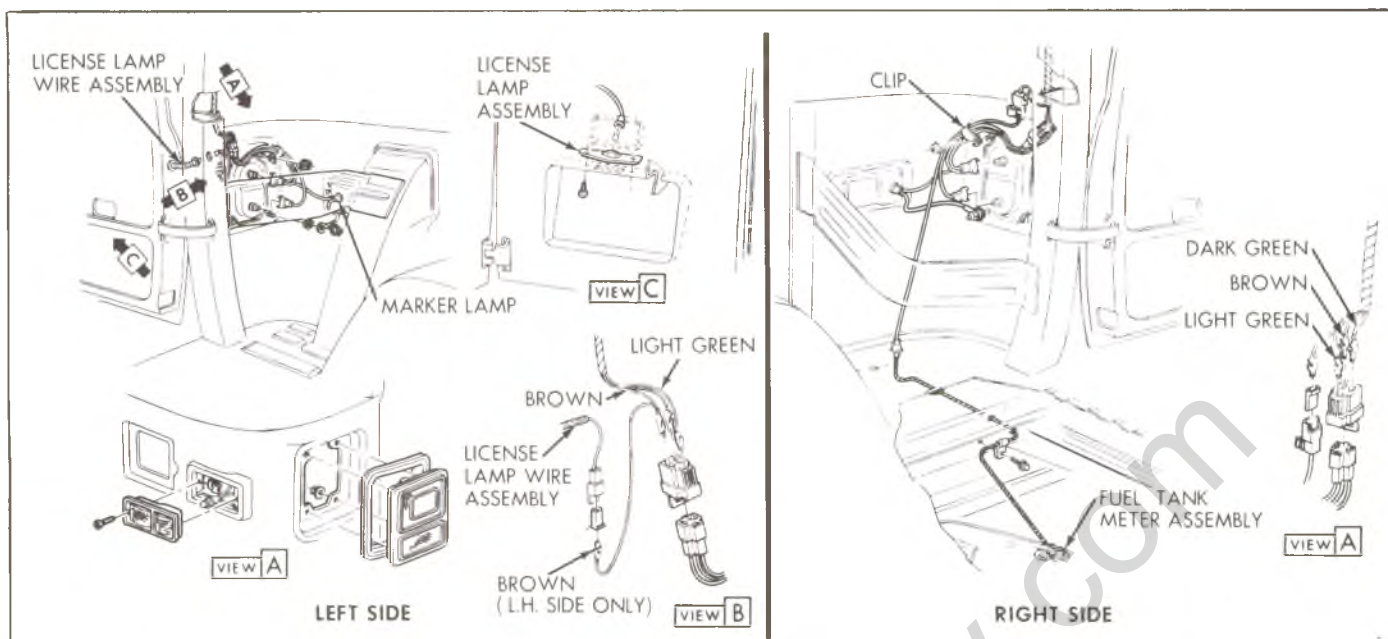

Fig. 5--Rear Lighting (G Models)

### REAR SIDE MARKER LAMP BULB AND/OR HOUSING

#### C-K 03 Models with E62 and G Models

##### Replacement

Same as Right Front Side Marker Lamp Bulb and/or Housing Replacement - All Vehicles.

NOTE: Bulb on G Models without interior trim may be removed from inside the vehicle.

#### C-K 14, 03 and 63 with E63, and 06 Models

##### Replacement

1. Remove lens to housing four screws.
2. Replace bulb and check operation.
3. Position lens and install four attaching screws.

#### Platform and Stake Rack Models (E56)

Exploded views of the different rear lighting arrangements are shown in Figures 7 and 8. The bulbs may be replaced by removing the lamp lens attaching screws and lamp lens. The lamp housings may be replaced by removing the housing attaching nuts or screws, or by removing the nuts and bolts from the bracket.

### TAIL, STOP AND BACKUP LAMP BULBS

##### Replacement

1. Remove lens to housing attaching screws.
2. Replace bulb and check operation.
3. Position lens and install attaching screws.

### TAIL, STOP AND BACKUP LAMP HOUSING C-K 14, 03 and 63 w/E63 and 06 Models

#### All G Models

##### Replacement

1. Remove lens to housing attaching screws.
2. Remove bulbs from sockets.
3. Remove housing attaching screws (nuts on G Models).
4. Rotate wiring harness sockets counterclockwise and remove housing.
5. To install, reverse Steps 1-4 above.

### DIRECTIONAL SIGNAL LAMPS

Directional signal lamps are an integral part of parking and tail lamp assemblies. Refer to the applicable lamp or bulb replacement procedures covered previously.

### CLEARANCE LICENSE PLATE AND IDENTIFICATION LAMPS

Refer to Figures 7 through 10 for clearance and identification lamp installations.

### LIGHT SWITCH

#### C-K Models (Fig. 11)

##### Replacement

1. Disconnect the battery ground cable.
2. Reaching up behind instrument cluster, depress shaft retaining button and remove switch knob and rod.

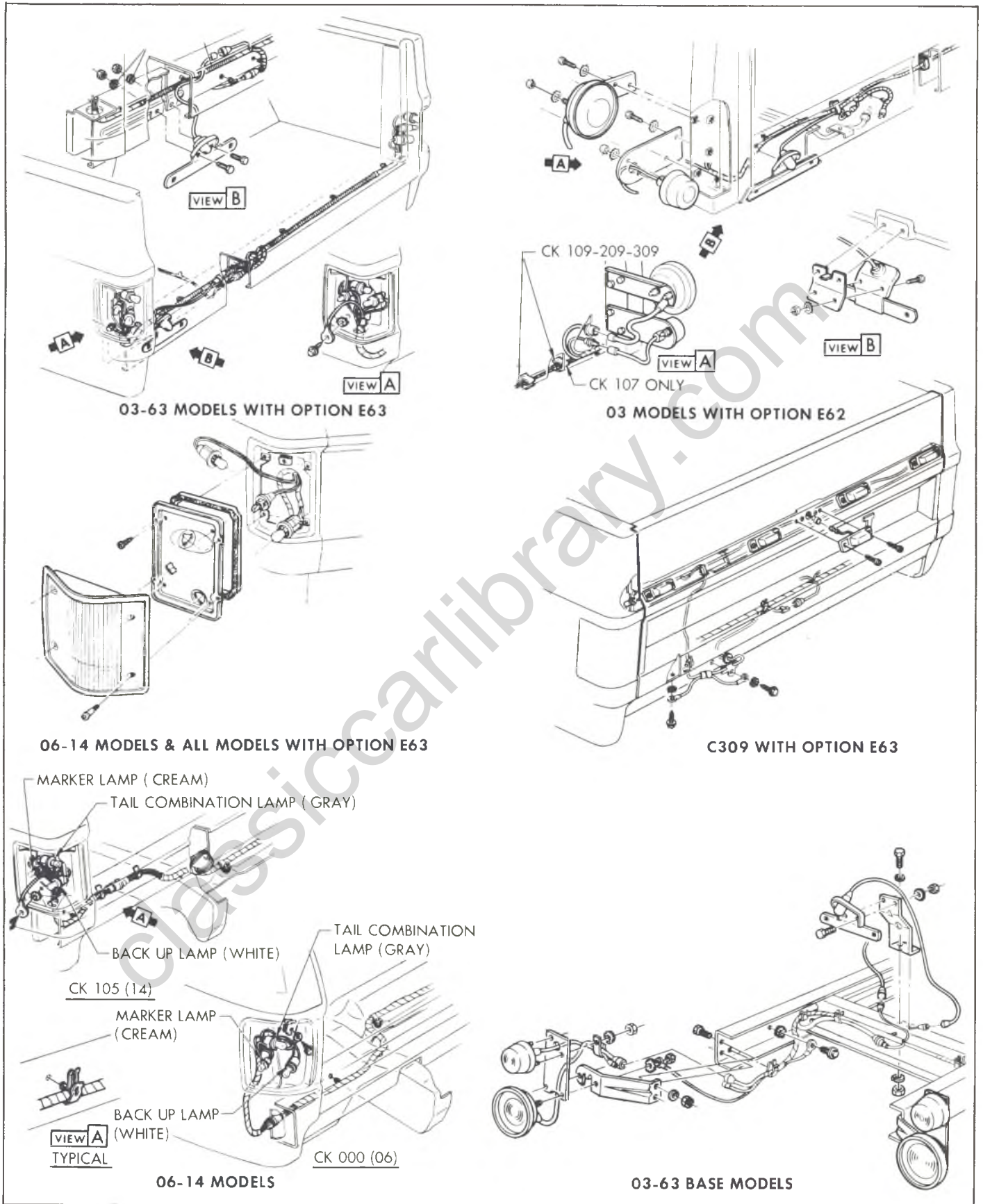

Fig. 6--Rear Lighting (C-K Models Except with E56 or E62)



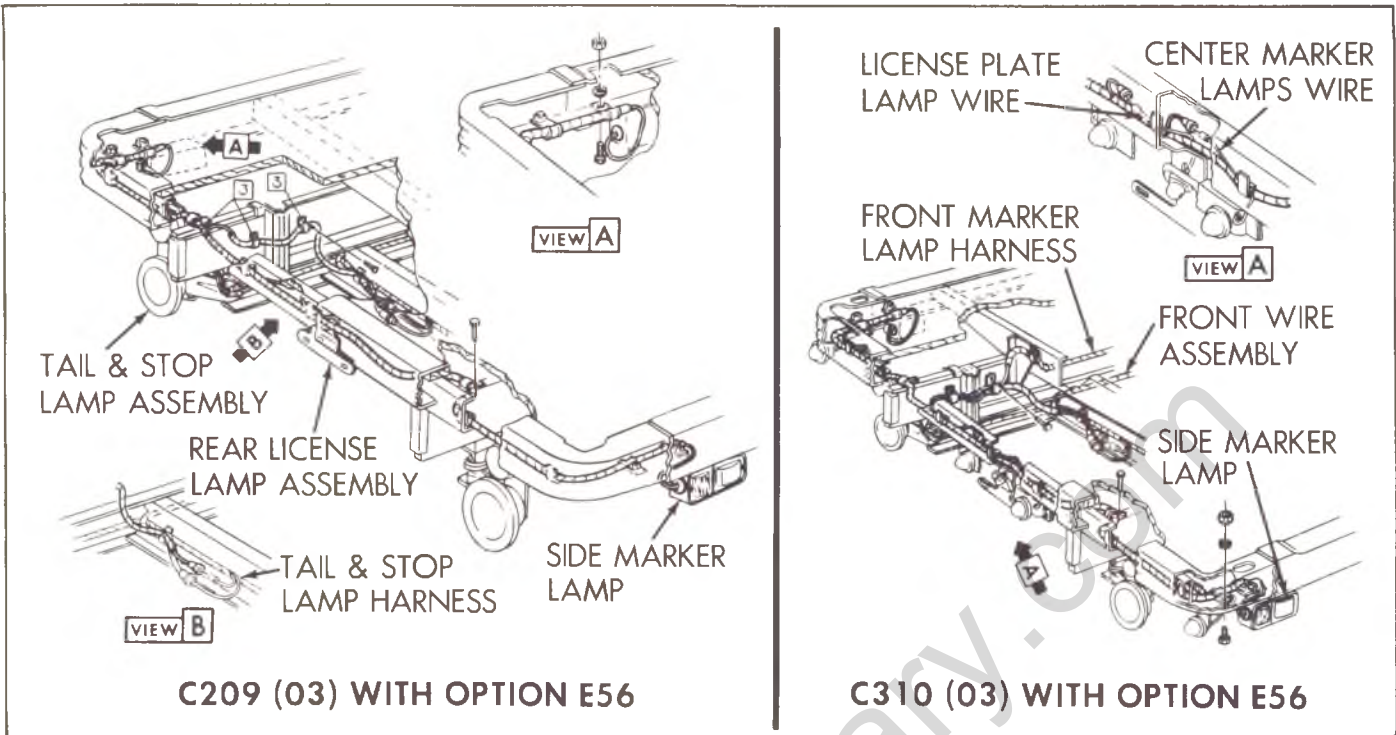

Fig. 7--Rear Lighting (C-K Platform and Stake Rack Models)

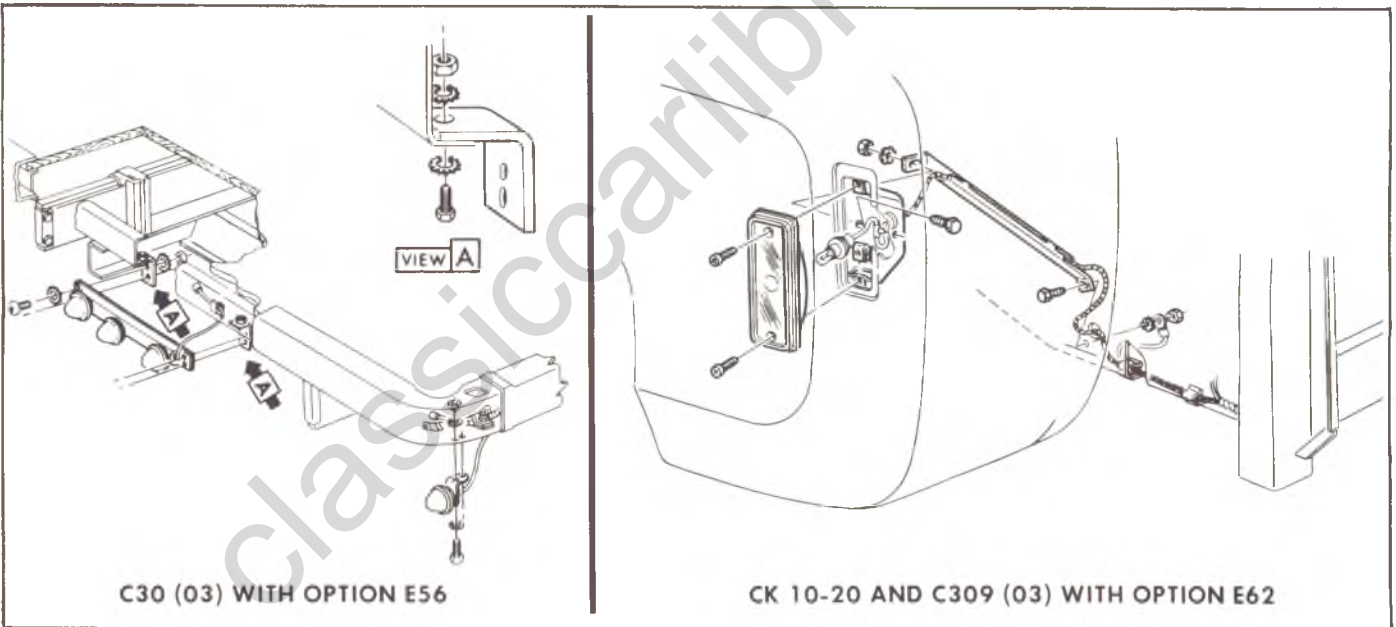

Fig. 8--Rear Lighting (C30 03 Models with E56 and C-K Models with E62)

3. Remove instrument cluster bezel screws on left end. Pull out on bezel and hold switch nut with a wrench.
4. Disconnect multiple wiring connectors at switch terminals.
5. Remove switch by rotating while holding switch nut.

6. To install, reverse Steps 1-5 above.

**G Models (Fig. 11)**

**Replacement**

1. Disconnect battery ground cable.
2. Reaching up behind instrument panel, depress shaft retaining button and remove switch knob-shaft.

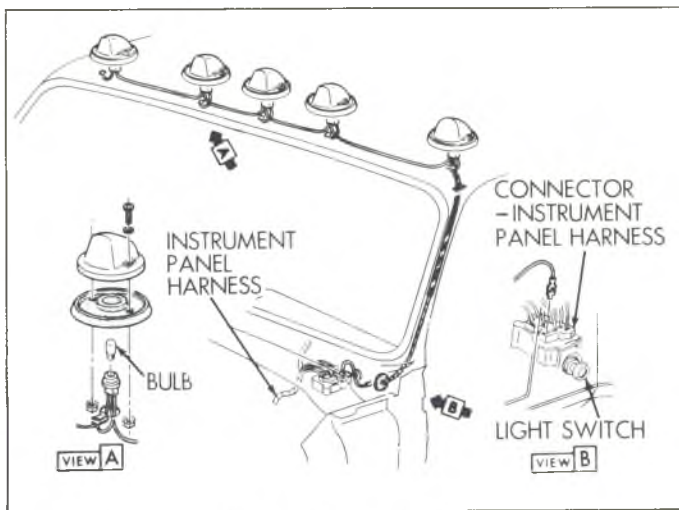

Fig. 9--Clearance Lamps

3. From front of instrument panel remove switch retaining nut.
4. Push switch from panel opening and remove multiple electrical connector at switch terminals.
5. To install, reverse Steps 1-4, making sure grounding ring is installed on switch.

## DIMMER SWITCH

### Replacement

1. Fold back upper left corner of the floor mat and remove two screws retaining switch to the floor pan.
2. Disconnect wiring connector from switch terminals.
3. Connect wiring to replacement switch and check operation.
4. Position switch to floor pan and install retaining screws.
5. Replace floor mat.

## STOPLAMP SWITCH

See Section 5 (Brakes) of this manual for adjustment and replacement procedures.

## NEUTRAL START SWITCH

### C-K Models (Fig. 12)

#### Replacement and Adjustment

1. Disconnect battery ground cable.
2. Disconnect electrical harness at switch.
3. Remove switch mounting screws and remove switch.
4. Position shift lever in neutral gate notch.
5. Insert .096" gauge pin to a depth of 3/8 inch into switch gauge hole. Switch assembly is fixed in neutral position with internal plastic shear pin.
6. Assemble the switch to column by inserting the

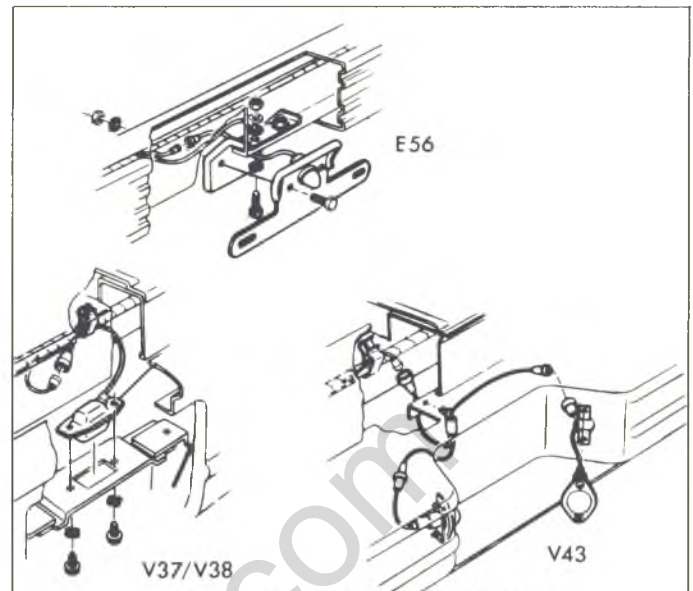

Fig. 10--License Plate Lamps (C-K Models)

switch carrier tang in the shift tube slot and fasten in position by assembling mounting screws to retainers.

NOTE: If retainer strips out it must be replaced.

7. Remove .096" gauge pin.
8. Move shift lever out of neutral gate notch to park gate position to shear switch internal plastic pin.
9. Return shift lever to neutral gate notch.
10. Switch gauge hole will freely admit .089" gauge pin to a depth of 3/8 inch.
11. If pin will not freely enter gauge hole, switch must be reset as below.
12. Connect battery ground cable and electrical harness.

#### Reset Installation Procedure

1. Place shift lever in neutral gate notch.
2. Loosen attaching screws.
3. Rotate switch on column and insert .096" gauge pin to depth of 3/8 inch.
4. Tighten attaching screws.
5. Repeat installation procedure Steps 7 through 12 above.

## G-P Models

### Replacement (Fig. 12)

1. Raise vehicle on a hoist.
2. Disconnect the switch harness from the switch.
3. Remove switch mounting bolts and remove switch.
4. Assemble new switch loosely to mounting bracket.
5. Align .093/.097 hole in Lever (B) with hole in Switch Assembly. Insert Pin (A) to hold in NEUTRAL position.

## 12-8 ELECTRICAL - BODY AND CHASSIS

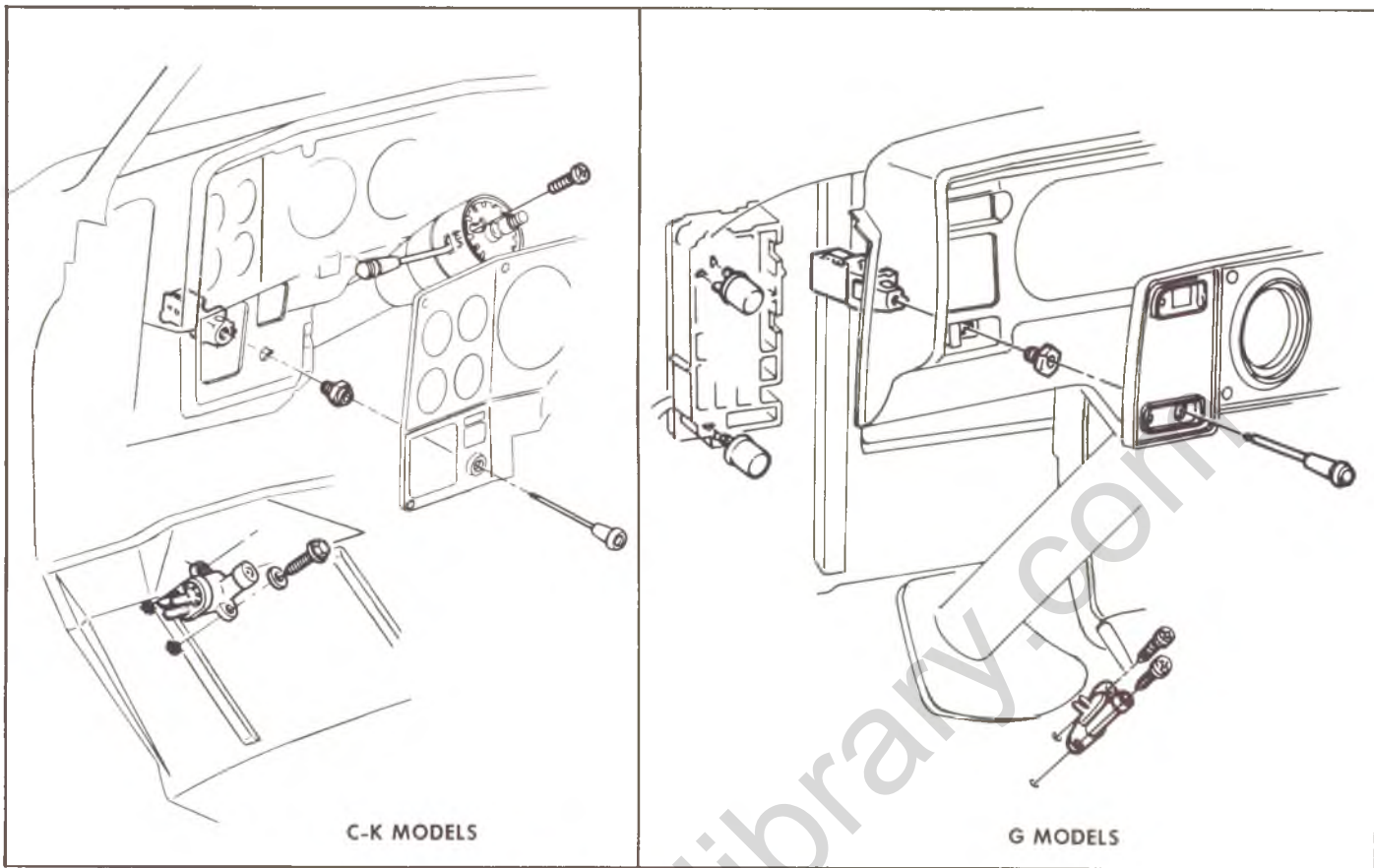

Fig. 11--Light and Dimmer Switches

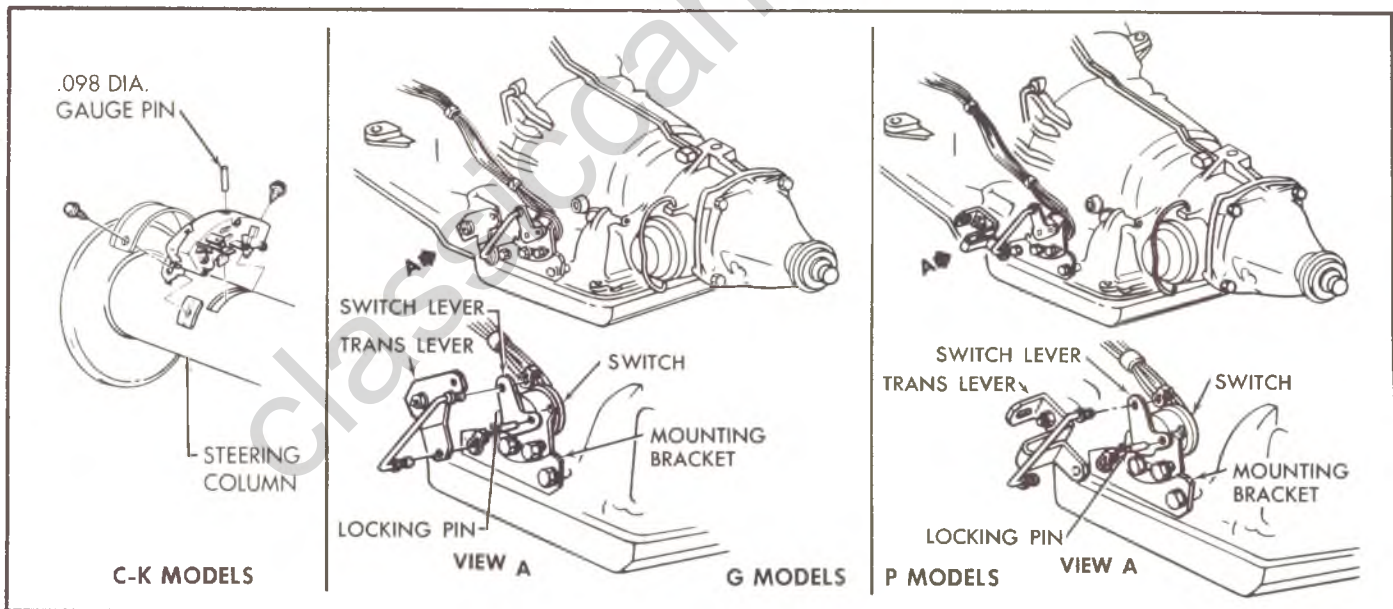

Fig. 12--Neutral Start Switch Replacement - Typical

- Set Transmission Lever (C) in NEUTRAL position by the following method.

**NOTE:** Obtain NEUTRAL by moving Transmission Lever counterclockwise to L1

detent, then clockwise three detents to the NEUTRAL detent position.

- Install Rod into Transmission Lever and Switch Lever. Secure with clips.

8. Tighten switch attaching screws.
9. Lower vehicle from hoist and carefully check switch operation.

### BACKING LAMP SWITCH

See "Neutral Start Switch" for automatic transmission models.

### Column Mounted Switch (Manual Transmission)

#### Replacement

1. Disconnect battery ground cable.
2. Disconnect switch wiring harness.
3. Remove column mounting screws and remove switch.
4. Assemble the switch to the column. Fasten in position by installing mounting screws.
5. Install battery ground cable.
6. Check operation to make sure back-up lights come on in reverse gear only.

### Transmission Mounted Switch

#### Replacement

1. Raise vehicle on a hoist.
2. Disconnect switch wiring harness.

3. Remove switch from transmission.
4. To install a new switch, reverse Steps 1-3 above.

### WINDSHIELD WASHER/WIPER SWITCH

#### C-K Models

##### Replacement

1. Disconnect battery ground cable.
2. Remove instrument panel bezel screws and bezel.
3. Remove switch attaching screws.
4. Pull out on switch assembly and disconnect electrical harness - remove switch.
5. To install, reverse Steps 1-4 above. Check switch operation before reinstalling instrument panel bezel.

#### G Models

##### Replacement

1. Disconnect battery ground cable.
2. Reach up behind left side of instrument panel, and:
  - a. Remove plug connector from rear of switch.
  - b. Remove (3) mounting screws securing bezel and ground wires to switch.
3. Replace switch, installing ground wire and connector. Check operation of switch, first observing washer solvent level.

## INSTRUMENTS AND GAUGES

### INDEX

General Description .....	12-9	Speedometer Cable .....	12-13
Component Part Replacement .....	12-10	Fuel Gauge .....	12-13
Ignition Switch .....	12-10	Temperature Gauge .....	12-13
Instrument Cluster .....	12-10	Temperature Sending Unit .....	12-14
Indicator and Illuminating Bulb .....	12-12	Oil Pressure Gauge .....	12-14
Laminated Circuit .....	12-12	Oil Pressure Sending Unit .....	12-14
Speedometer .....	12-12	Ammeter Gauge .....	12-14

## GENERAL DESCRIPTION

All instruments and gauges are installed in the instrument cluster. Instruments and gauges can be

serviced in the vehicle (C-K Models); however, the entire cluster must be removed from the vehicle for servicing

of the instruments and gauges (G Models). Illuminating and indicator lamps may be replaced without removing the cluster from the vehicle. Bulbs are installed in plastic holders which lock into the cluster housing.

Regular maintenance is not required on the instrument cluster or its components other than maintaining clean, tight electrical connections, replacing defective parts and keeping the speedometer cable properly lubricated.

## COMPONENT PART REPLACEMENT

### IGNITION SWITCH

#### C-K Models

See Section 9 - Steering, for ignition switch replacement procedure.

#### G Models

##### Replacement (Fig. 13)

1. Disconnect ground cable from battery.
2. Remove lock cylinder by positioning switch in "ACC" position and inserting stiff wire in small hole in cylinder face. Push in on wire to depress plunger and continue to turn key counterclockwise until lock cylinder can be removed.
3. Remove the metallic ignition switch nut.
4. Pull the ignition switch out from behind the instrument panel and remove the "theft resistant" connector. Use a screwdriver to unsnap the locking tangs on the connector from their position on the switch.
5. Snap the connector into place on a new ignition switch.
6. Place the switch into position from behind the instrument panel, first adding grounding ring then install the ignition switch nut.
7. Install the lock cylinder, key inserted.
8. Install ground cable on battery.

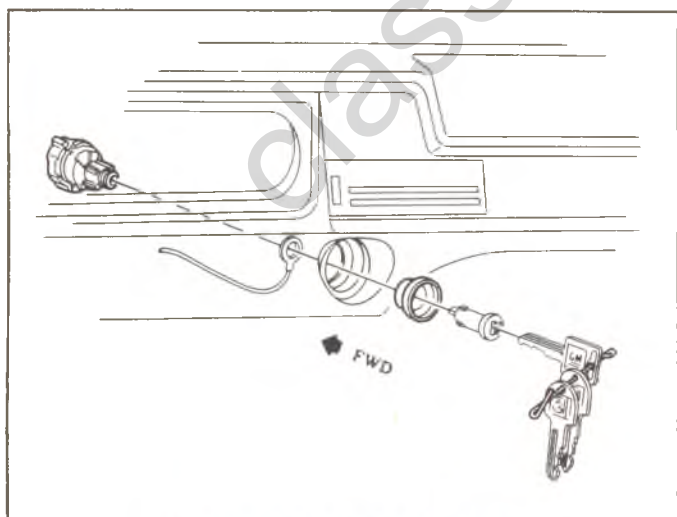

Fig. 13-Ignition Switch (G Models)

### INSTRUMENT CLUSTER

#### C-K Models

##### Replacement (Fig. 14)

1. Disconnect the battery ground cable.
2. Remove the instrument cluster bezel and steering column cover screws and remove the bezel and cover.
3. Remove the clock knob (if so equipped).
4. Remove the lens retaining screws and remove the lens.
5. Remove the transmission PRNDL indicator retaining screws and remove the indicator. Remove the cluster retainer.
6. Reach up under the dash and disconnect the speedometer cable by depressing spring clip and pulling cable out of speedometer head. Disconnect oil pressure line (if so equipped).
7. Disconnect cluster wiring harness.
8. Remove cluster retaining screws and remove cluster.
9. Remove cluster assembly to workbench for further disassembly as required.
10. To install, reverse Steps 1-8 above.

#### G Models

##### Replacement (Fig. 15)

1. Disconnect battery ground cable.
2. Reach up under instrument cluster and disconnect speedometer cable by first depressing tang on rear of speedometer head, then pulling cable free from head as tang is depressed.
3. Unplug instrument panel harness connector from printed circuit.
4. Disconnect oil pressure line from gauge if so equipped.
5. Remove two nuts attaching instrument cluster studs to lower opening in instrument panel.
6. Pull top of cluster away from instrument panel and lift out bottom of cluster.
7. Remove cluster to bench for further disassembly (laminated printed circuit, speedometer head, gauges).
8. Install cluster in reverse order of removal, noting that clips at top of cluster slip into instrument panel opening after bottom of cluster is installed.

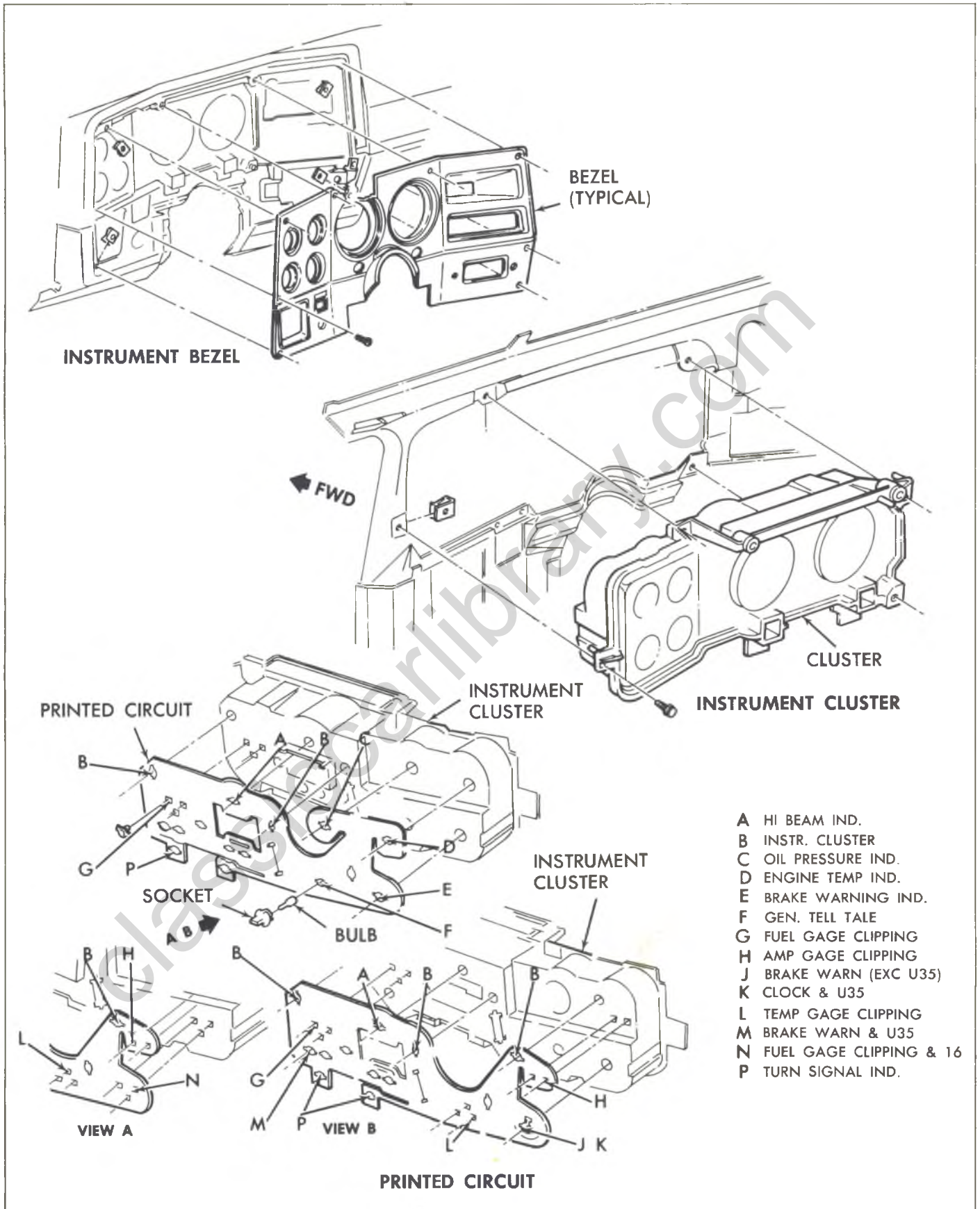

Fig. 14-Instrument Cluster Assembly (C-K Models)

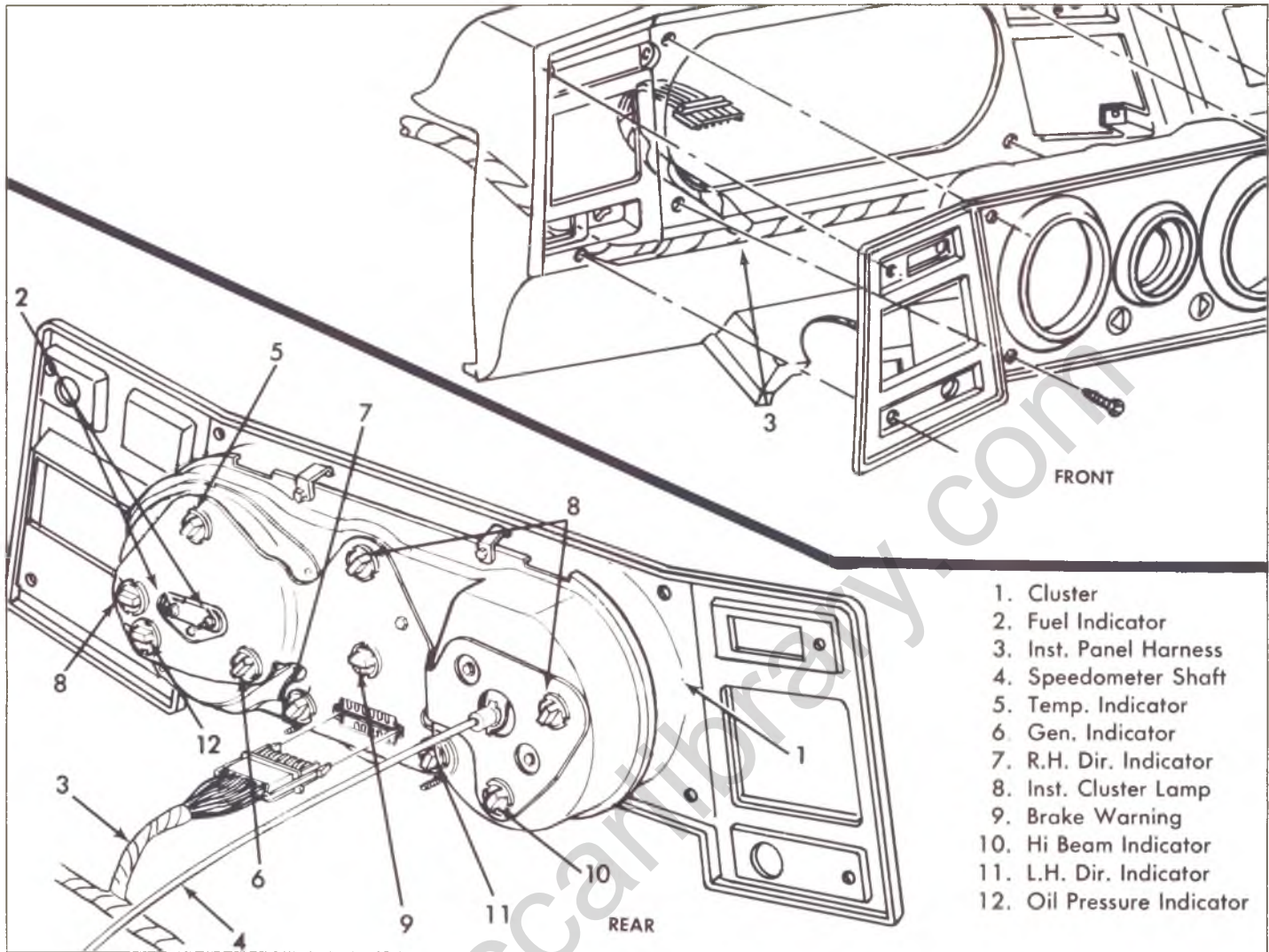

Fig. 15-Instrument Cluster Assembly (G Models)

## INDICATOR AND ILLUMINATING BULBS

### All Models

#### Replacement (Figs. 14 and 15)

1. Reach up under instrument panel and turn bulb holder counterclockwise to remove from the cluster housing.
2. Pull bulb straight out to remove from holder.
3. Install replacement bulb in holder, press inward to lock in place.
4. Insert holder into housing, with lugs on holder entering notches in case, and turn clockwise to lock holder against printed circuit.

### LAMINATED CIRCUIT—All Models

#### Replacement

1. Remove instrument cluster assembly as previously described in this section.
2. Remove all instrument cluster lamp bulb assemblies.

3. Remove laminated circuit retaining screws.

NOTE: These screws serve as a ground for the circuit and must be reinstalled to provide the proper ground.

4. **G Models** - Remove fuel, temperature and ammeter terminal nuts retaining laminated circuit to rear of cluster.
5. Lift laminated circuit from cluster cover.
6. To install, reverse Steps 1-5 and check electrical operation of all affected components.

### SPEEDOMETER

NOTE: Servicing of the speedometer assembly should only be performed by trained technicians having the proper test equipment.

### C-K Models

#### Replacement

1. Disconnect the battery ground cable.

2. Remove headlamp switch control knob.
3. Remove radio control knobs and clock adjuster stem.
4. Remove instrument cluster bezel and steering column cover.
5. Remove instrument cluster lens.
6. Remove transmission PRNDL indicator and case front cover.
7. Remove speedometer to cluster screws and speedometer assembly.
8. To install, reverse removal procedure. Check speedometer operation.

## G Models

### Replacement

1. Remove instrument cluster as previously described in this section.
2. Remove four screws retaining cluster rear cover containing speedometer.
3. Remove two hex head screws and rubber grommets securing speedometer assembly to cluster cover.
4. To install, reverse removal procedure and check operation of speedometer assembly.

**CAUTION:** Use care to prevent kinking the speedometer cable during removal and installation.

## SPEEDOMETER CABLE CORE

### All Vehicles

#### Replacement

1. Disconnect battery ground cable.
2. Disconnect speedometer cable from speedometer head by reaching up under instrument panel, depressing spring clip and pulling cable from head.
3. Remove old core by pulling it out at end of speedometer cable casing.

**NOTE:** If old cable core is broken it will be necessary to remove lower piece from transmission end of casing.

4. Lubricate entire length of cable core with speedometer cable lubricant.
5. To install, reverse Steps 1-3 above.

**CAUTION:** Use care to prevent kinking speedometer cable core during installation.

## FUEL GAUGE

### C-K Models

#### Replacement

1. Perform Steps 1-5 of "Instrument Cluster - Replacement".
2. Remove fuel gauge attaching screws and remove the gauge.
3. To install, reverse Steps 1-2 above. Check gauge operation.

### G Models

#### Replacement

1. Remove instrument cluster assembly as previously described.
2. Remove instrument cluster bulb holders, ground screws, nuts and washers retaining laminated circuit to fuel gauge rear cover.
3. Remove three screws retaining fuel gauge rear cluster cover.
4. Lift gauge away from laminated circuit and rear cluster cover.
5. To install, reverse Steps 1-4 and check operation of fuel gauge.

**NOTE:** Mount insulator strip on fuel gauge studs first, then resistor, then a nut on each stud, next the laminated circuit, then a plain washer on each of two studs holding laminated circuit and finally a nut on back of the studs that have a washer and laminated circuit.

## TEMPERATURE GAUGE

### C-K Models

#### Replacement

1. Perform Steps 1-5 of "Instrument Cluster - Replacement".
2. Remove temperature gauge attaching screws and remove the gauge.
3. To install, reverse Steps 1 and 2 above and check gauge operation.

**NOTE:** Be sure gauge studs engage clips holding laminated circuit to back of cluster housing.

### G Models

#### Replacement

1. Remove instrument cluster assembly as previously described in this section.
2. Remove terminal nuts retaining laminated circuit to gauge unit.
3. Remove attaching screws, cover and gauge assembly from cluster housing.
4. Remove terminal attaching nuts and gauge unit from cover plate.



## 12-14 ELECTRICAL - BODY AND CHASSIS

5. To install, reverse removal procedure and check operation of gauge.

### TEMPERATURE SENDING UNIT

#### All Models

##### Replacement

**WARNING:** Do not remove cap with engine hot, allow vehicle to cool off first.

1. Relieve cooling system pressure by loosening radiator cap to first stop. Tighten cap after pressure is relieved.
2. Disconnect sending unit wiring harness.
3. Remove sending unit from the engine.
4. Install new sending unit and connect electrical harness.
5. Check coolant level and unit operation.

NOTE: Coolant must have at least 0°F. freeze protection for sending unit to function properly.

### OIL PRESSURE GAUGE

#### C-K Models

##### Replacement

1. Perform Steps 1-5 of Instrument Cluster - Replacement" procedure.
2. Reach up under the instrument panel and place a cloth under the line to gauge connection. Remove line to gauge nut.
3. Remove gauge to cluster attaching screws and remove gauge.
4. To install, reverse Steps 1-3 above and check gauge operation.

#### G Models

##### Replacement

1. Remove instrument cluster as previously described in this section.  
NOTE: Oil pressure line connection may leak oil when opened; wrap with cloth.
2. Remove bulb holders, grounding screws and lift laminated circuit aside as necessary.
3. Remove instrument cluster cover to separate oil pressure gauge from cluster.
4. Remove pipe fitting and retaining nut from gauge

being replaced then remove gauge from cluster DO NOT KINK PIPE.

5. To install replacement oil pressure gauge, reverse Steps 1-4, then observe operation of gauge.

### OIL PRESSURE SENDING UNIT

#### All Models

##### Replacement

1. Disconnect wiring harness connector from sending unit terminal located in block above starter on L-6 engines, at left front of distributor on V-8 (except 454 V-8) or rear left side of block (454 V-8) engines.
2. Remove sending unit using Tool J-21757. Replace with new unit and check operation.

### AMMETER GAUGE

#### C-K Models

##### Replacement

NOTE: First check two in-line fuses at front of engine compartment.

1. Perform Steps 1-5 of "Instrument Cluster - Replacement" procedure.
2. Remove the gauge to instrument panel screws and remove the gauge.
3. To install, reverse Steps 1 and 2 above and check gauge operation.

NOTE: Be sure gauge studs engage clips holding printed circuit to back of cluster housing.

#### G Models

##### Replacement

NOTE: First check two in-line fuses at front of engine compartment.

1. Remove instrument cluster assembly as previously described in this section.
2. Remove terminal nuts retaining laminated circuit to ammeter.
3. Lay back laminated circuit portion after removing grounding screws and bulb holders.
4. Remove attaching screws, cover and ammeter from cluster housing.
5. Remove terminal attaching nuts and ammeter from cover plate.
6. To install, reverse Steps 1-5 and check operation of ammeter.

## DIRECTIONAL SIGNAL SWITCH

The directional signal switch is a self-contained unit which incorporates the hazard warning switch and the lane changing signal.

The hazard warning circuit is activated by a push-pull switch which is located on the right side of the steering column, opposite the directional signal lever. The switch knob must be pulled to cancel circuit.

The lane changing circuit is activated by holding the directional signal lever in the first detent position; there is no lock in or cancelling device in this position.

See Section 9 "Steering" for all servicing procedures.

## WINDSHIELD WIPER AND WASHER C-K-G MODELS

### INDEX

General Description .....	12-15	Motor Assembly .....	12-23
Theory of Operation .....	12-16	Adjustments .....	12-24
Service Operations .....	12-19	Windshield Washer Pump Assembly.....	12-24
Wiper Motor .....	12-19	Diagnosis.....	12-25
Replacement .....	12-19	Wiper On Vehicle.....	12-25
Wiper/Washer Disassembly .....	12-20	Wiper Off Vehicle .....	12-26
Motor Disassembly .....	12-21	Washer System .....	12-32

### GENERAL DESCRIPTION

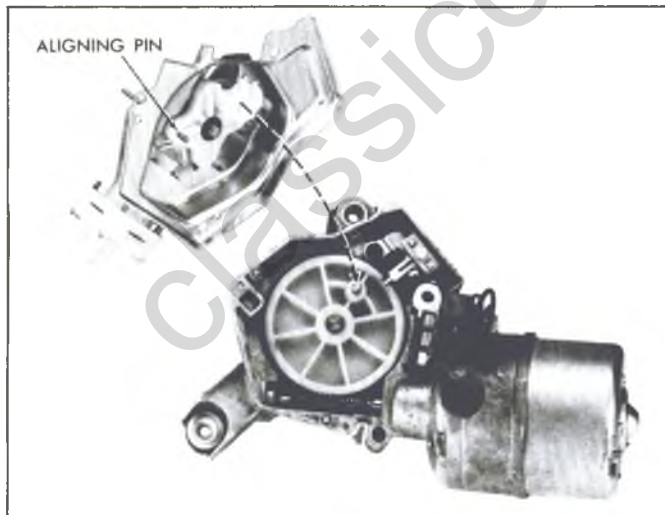

Fig. 16—Washer Mechanism Mounting on Wiper

The wiper motor assembly consists of compound wound 12 volt D.C. motor, gear reduction mechanism and parking switch enclosed in a common die cast housing. The armature has a worm shaft which drives a gear and shaft assembly. A crank arm, which is attached externally to the gear shaft, operates the linkage which activates the blades.

The wiper motor is equipped with an internal circuit breaker mounted on the motor brush plate which protects the motor from overheating.

Figure 16 shows the assembly of the washer pump to the wiper motor.

## THEORY OF OPERATION

### ELECTRICAL CIRCUITS

The following facts should be kept in mind throughout the following explanation.

1. The wiper dash switch is a grounding type switch, and therefore must be securely mounted.
2. When installed in a vehicle, the wiper motor is connected to the chassis through a ground strap. This in effect connects the wiper housing to the ground side of the battery.
3. The ignition switch opens and closes the feed wire circuit to the wiper. Therefore, it must be turned ON to operate wipers.

The wiper motor operation is controlled by two switches—a dash control switch and a parking switch located in the wiper motor gear box.

The parking switch contacts are normally closed and are opened by a cam on the gear when the wiper blades

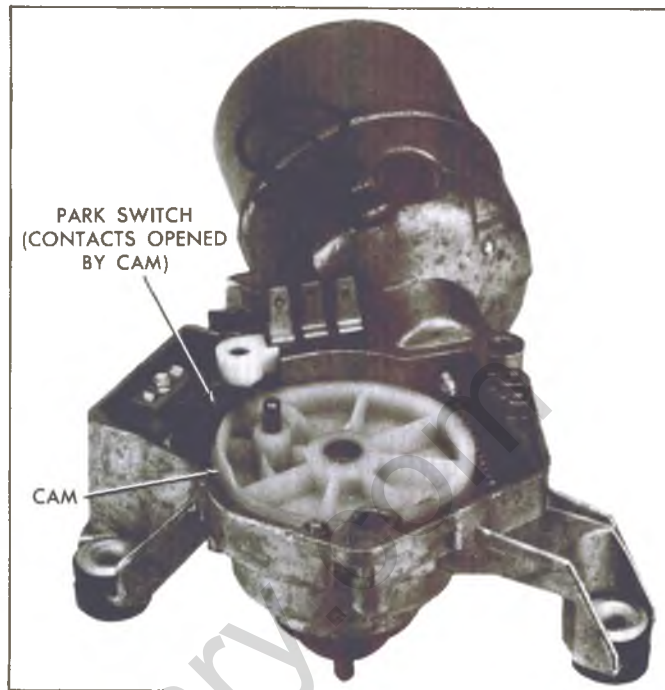

Fig. 17—Gear in PARK Position—Contacts Open

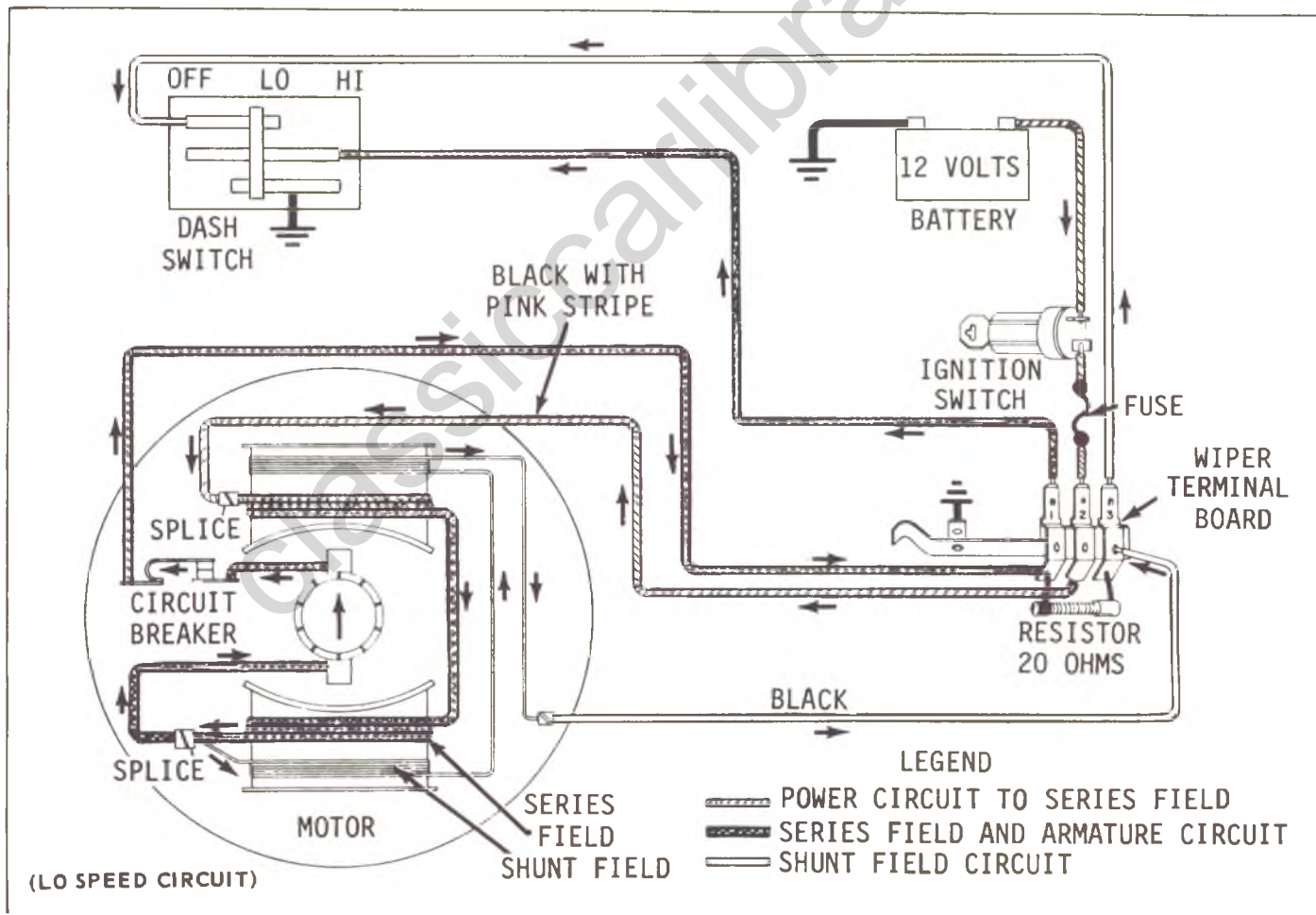

Fig. 18—LO Speed Circuit

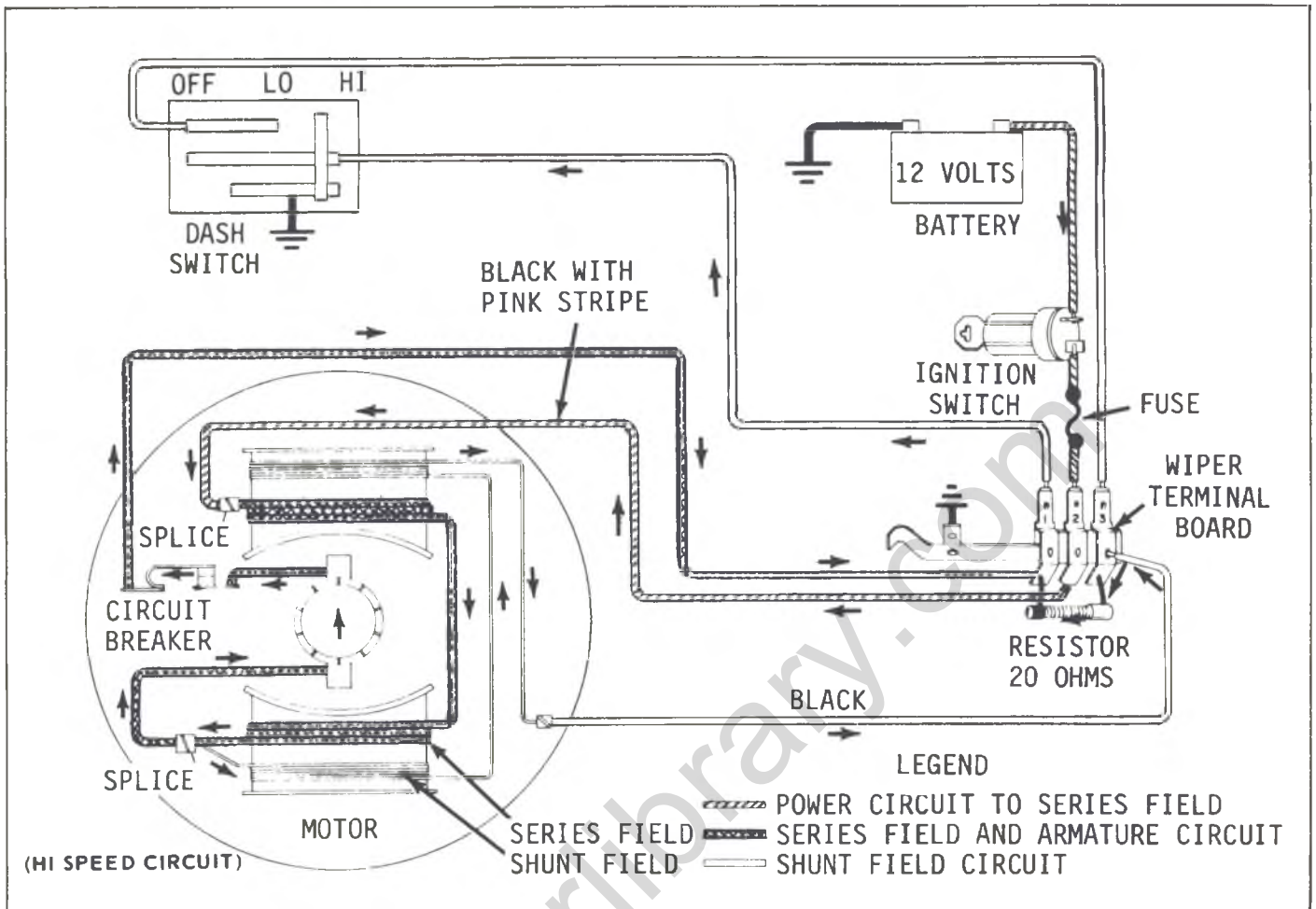

Fig. 19--HI Speed Circuit

reach the park position. The park switch acts as a holding switch to maintain the motor circuits to ground during that period of operation between the time the operator turns the wiper off at the dash switch and the blades reach the park position. Figure 17 shows the park switch contacts open.

### "Lo" Speed Operation

When the operator turns the wiper dash switch to the "LO" speed position, the wiper motor circuits are completed to ground at the dash switch as follows: (Refer to Figure 18). Current flows from the battery through the ignition switch to the center terminal of the wiper terminal board. From the center terminal, current then passes through the black with pink stripe lead to the series field coils (Larger diameter wire) where it divides and flows as follows:

1. The shunt field coils to wiper terminal No. 3 through the wiring harness to the dash switch to ground.
2. The series field-armature circuit is completed via wiper terminal No. 1 through the wiring harness to the dash switch to ground.

### "HI" Speed Operation

Turning the wiper dash switch to the "HI" or fast speed position changes the shunt field coil circuit as follows: (Refer to Figure 19).

With the dash switch in the HI speed position, the shunt field coil current passes through a 20 ohm resistor on the back of the wiper terminal board to terminal No. 1 and then via the wiring harness to the dash switch to ground. The armature and series field circuit is also completed via the wiring harness from wiper terminal No. 1 to the dash switch to ground.

### Turning the Wiper "OFF"

Turning the wiper dash switch to the OFF position opens the wiper circuits to ground at the dash switch. If, however, the wiper blades are in any position other than the normal park or off position, the wiper motor circuits are completed to ground by the wiper motor park switch as follows: (Refer to Figure 20).

1. The series field-armature circuit is completed to ground via the parking switch to the wiper housing to chassis of vehicle.
2. The shunt field coil circuit is completed to ground

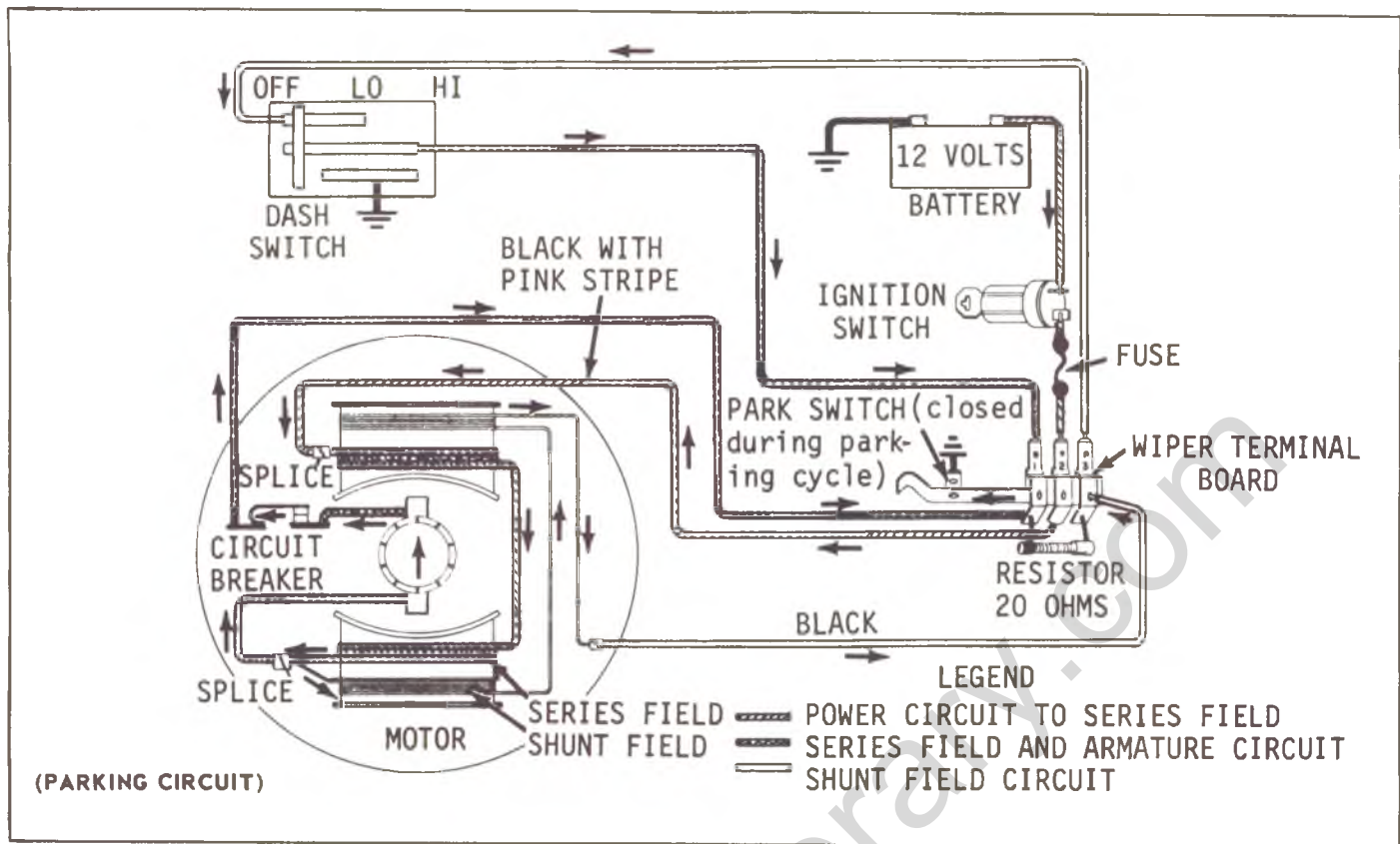

Fig. 20--PARKING Circuit

via wiper terminal No. 3 through the wiring harness to the dash wiring harness to wiper terminal No. 1, through the parking switch to ground.

**IMPORTANT:** Note that the shunt field circuit during the parking operation bypasses the resistor causing the wiper to operate in LO Speed. Failure of the wiper to operate in

LO Speed during parking results in the wiper failing to shut off.

With the wiper motor circuits completed to ground via the parking switch, the wiper motor continues to operate until the wiper gear cam opens the park switch contacts (Figure 17) stopping the wiper.

See Figure 21 for Wiper OFF Circuit.

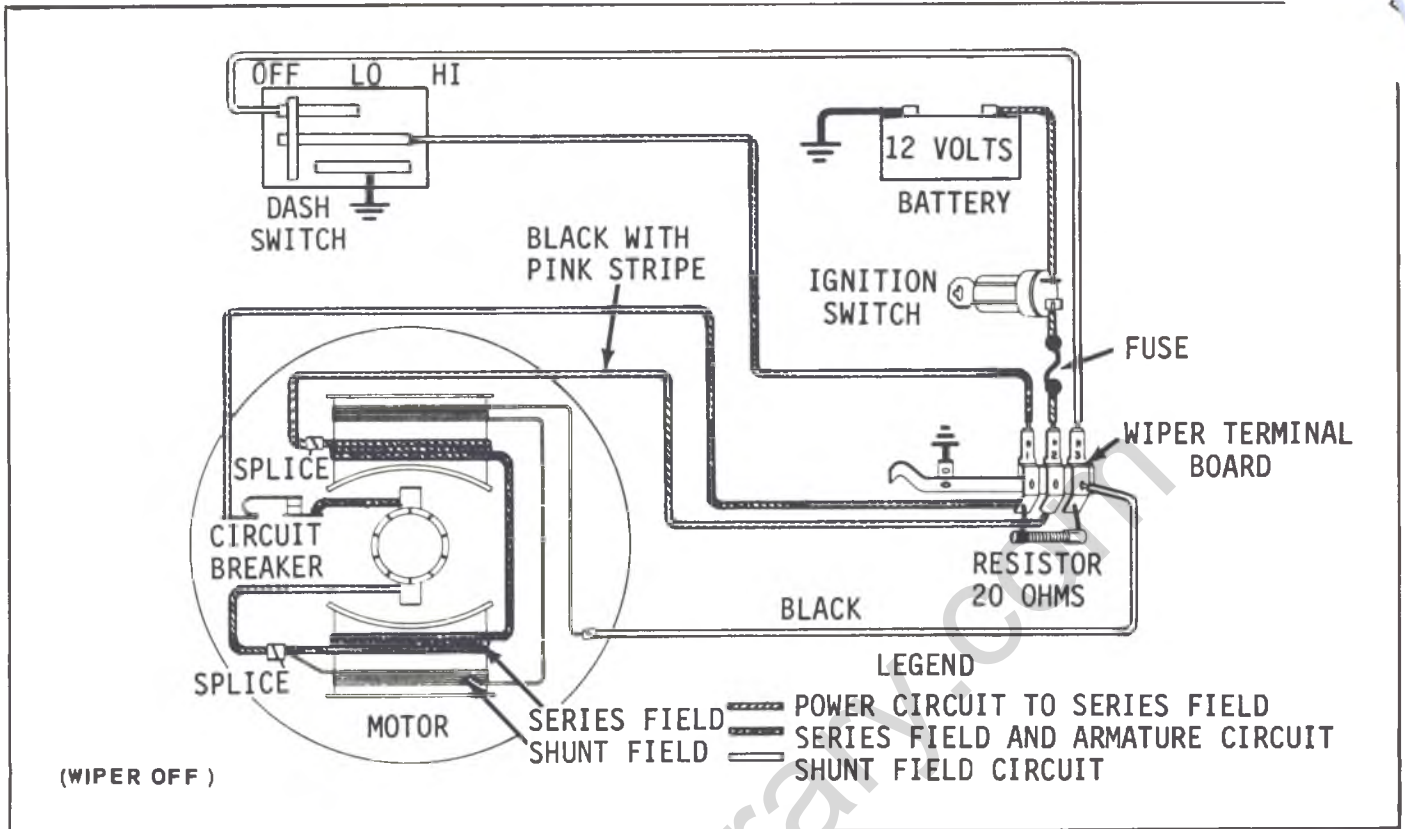

Fig. 21--OFF Circuit

## SERVICE OPERATIONS

### WIPER MOTOR

#### C-K Models

##### Replacement (Fig. 22)

1. Make sure wiper motor is in Park position.
2. Open hood and disconnect ground cable from battery.
3. Disconnect electrical harness at wiper motor and hoses at washer pump.
4. Reach down through access hole in plenum and loosen wiper drive rod attaching screws. Remove drive rod from wiper motor crank arm.
5. Remove wiper motor to dash panel attaching screws and remove the motor assembly.
6. To install, reverse Steps 1-5 above.

NOTE: Lubricate the wiper motor crank arm pivot prior to reinstallation.

#### G Models

##### Replacement (Fig. 23)

1. Make sure wiper motor is in Park position.

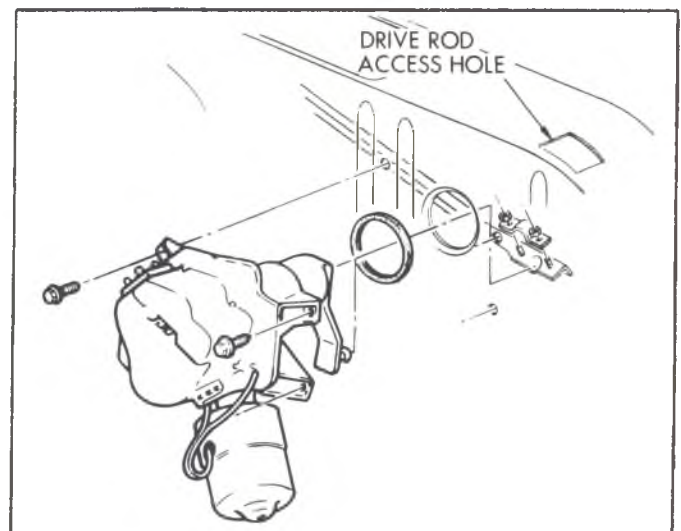

Fig. 22--Wiper Motor (C-K Models)

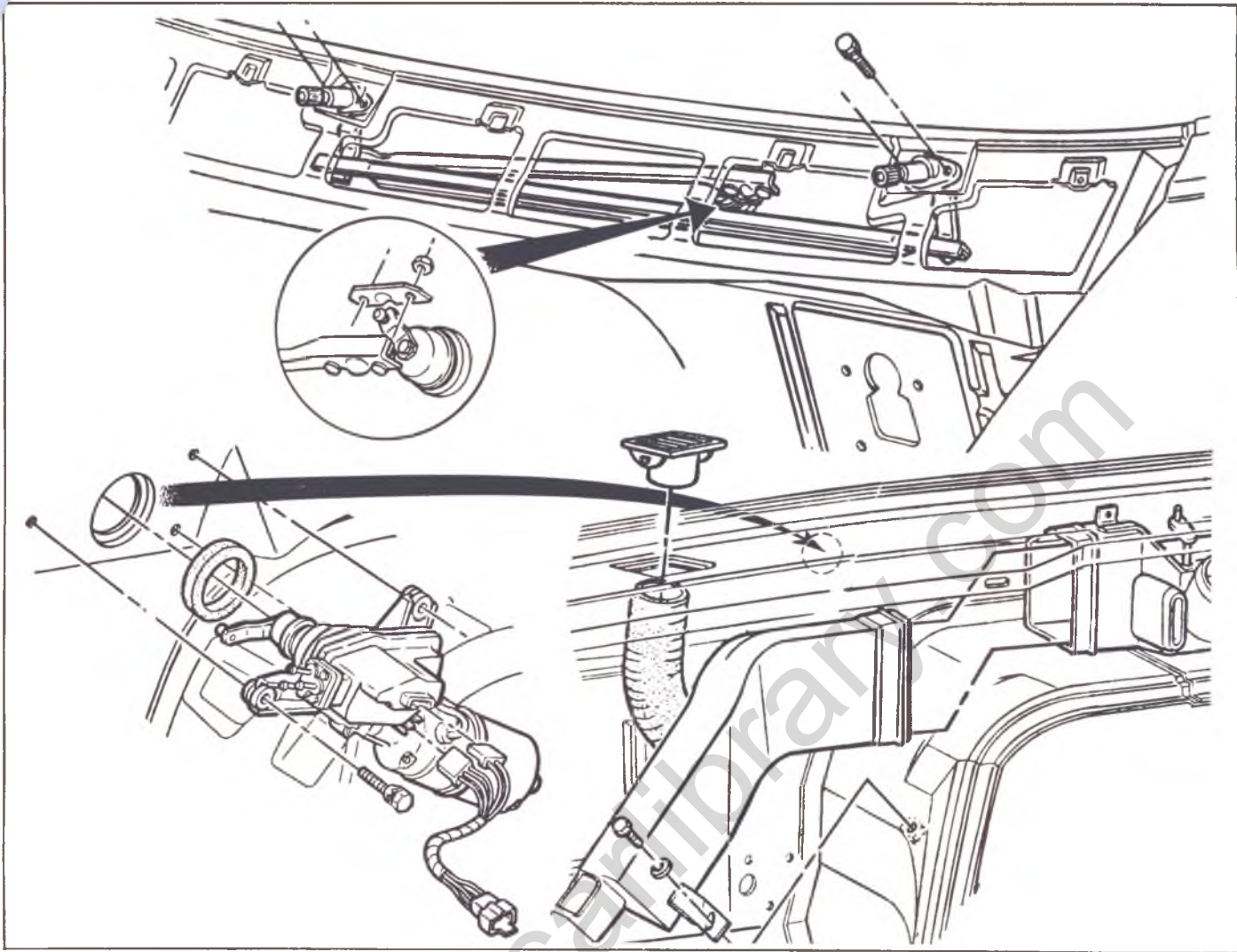

Fig. 23--Wiper Motor (G Models)

2. Open hood and disconnect ground cable from battery.
3. Remove wiper arms from wiper transmission linkage.
4. Remove remaining screws securing cowl panel cover and lift off.
5. Loosen nuts holding transmission linkage to wiper motor crank arm and lift linkage off arm.
6. Disconnect power feed to wiper motor at multiple connector.
7. Remove left dash defroster outlet from flex hose and push hose aside for access to wiper motor screws.
8. Remove one screw securing left hand heater duct to engine cover shroud and slip heater duct down and out.
9. Protect carpet, then remove windshield washer hoses from washer pump.
10. Remove three screws securing wiper motor to cowl

and lift wiper motor out from under dash for further disassembly on bench.

11. To install, reverse Steps 1-10 above.

NOTE: Install wiper in the PARK position. Lube wiper motor crank arm pivot prior to installation.

## WIPER/WASHER DISASSEMBLY

### Park Switch (Fig. 24)

1. Remove washer pump (fig. 16).
2. Remove screw retaining park switch.
3. Remove spacer.
4. Unsolder lead.

### Terminal Board (Fig. 24)

1. Remove washer pump.

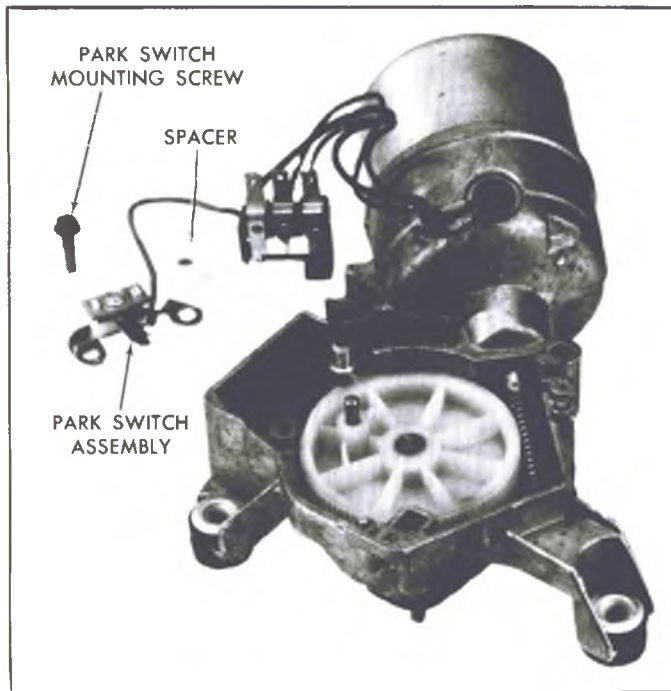

Fig. 24--PARK Switch Removal

2. Remove spacer.
3. Unsolder leads.

### Gear Assembly

1. Remove washer pump.
2. Remove park switch (See park switch removal). Unsolder lead only if required.
3. Clamp crank arm in vise and loosen crank arm retaining nut. Remove nut and crank arm (fig. 25).
4. Remove seal cap and using No. 22 External Snap Ring Pliers, remove the "C" retaining ring (fig. 26). Next, remove washer, end play washers, and outer spacer (fig. 27).
5. Slide the gear assembly out of the housing and remove the inner spacer washer (fig. 28).
6. To reassemble the gear box, reverse the disassembly procedure.

### Crank Arm Assembly

1. Operate wiper gear to park position (fig. 25).
2. Position crank arm on gear shaft flats according to position shown in Figure 25.
3. Install crank arm retaining nut finger tight, then clamp crank arm in vise and tighten retaining nut securely.

### MOTOR DISASSEMBLY

NOTE: Motor section may be disassembled independently of the gear box.

### Brush Plate and Circuit Breaker

#### Removal

1. Scribe a reference line along the side of the casting

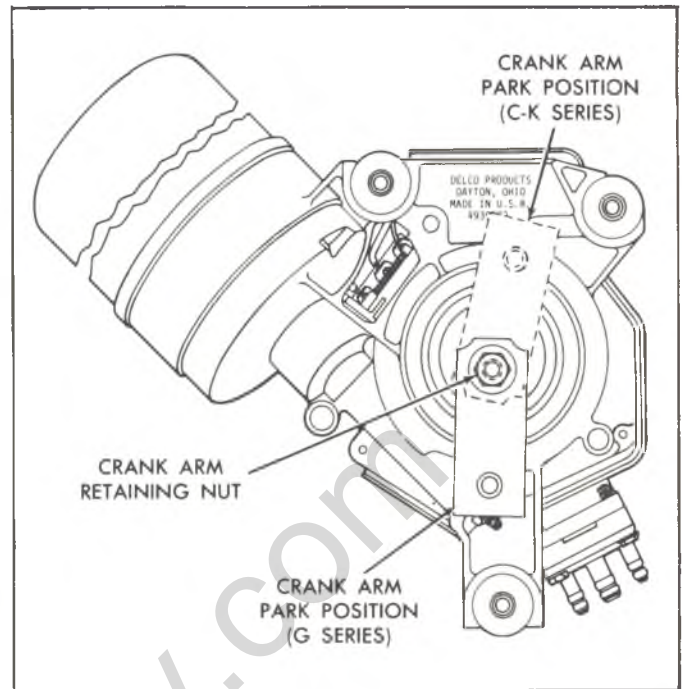

Fig. 25--Crank Arm in PARK Position

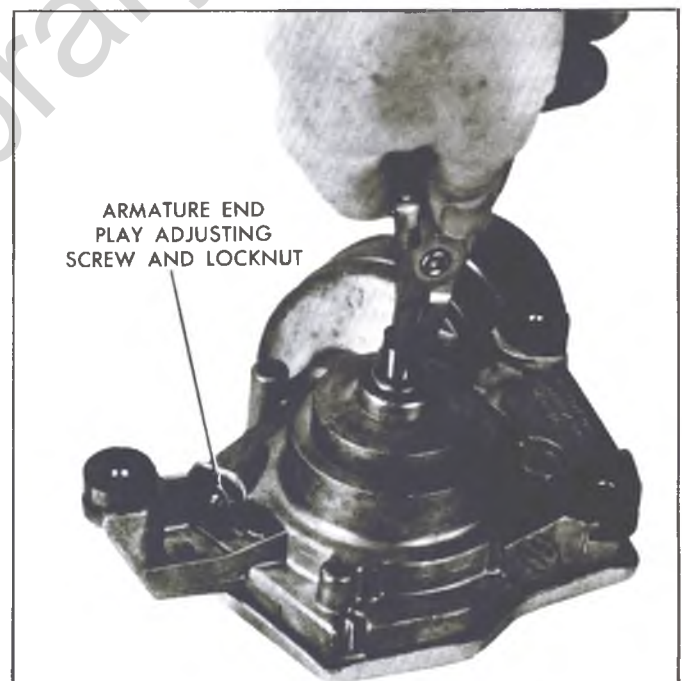

Fig. 26--"C" Ring Removal

- and end cap to insure proper reassembly.
2. Remove the two motor through bolts.
3. Feed exposed excess length of motor leads through the casting grommet and carefully back the case and field assembly plus the armature away from the casting (fig. 29).

NOTE: It may be necessary to remove the



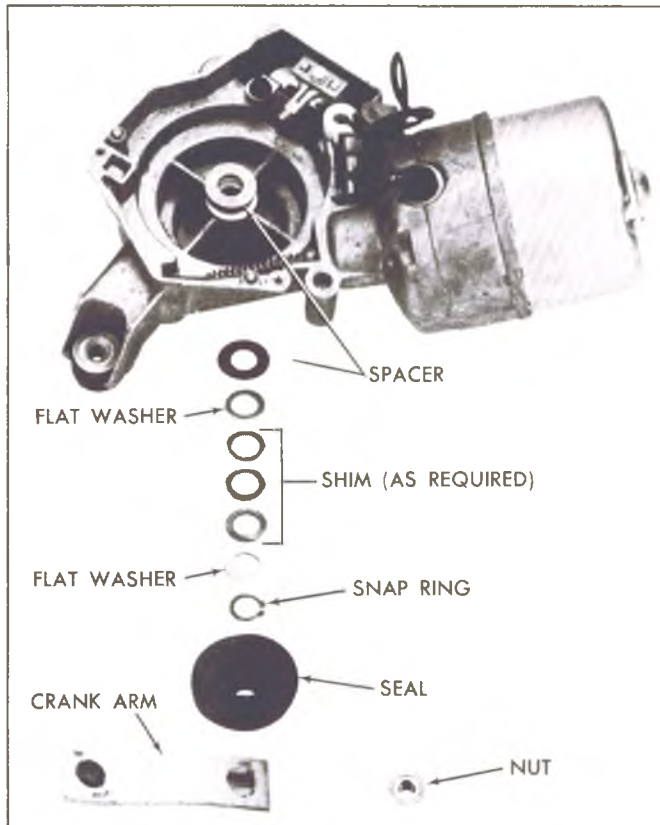

Fig. 27--Assembly Above Drive Gear

armature end play adjusting screw and insert a rod through the opening in order to apply pressure against the end of the armature.

4. Unsolder the black cotton-covered lead from circuit breaker (fig. 30).
5. Straighten out the four tabs that secure the brush plate to the field coil retainers (fig. 30).

**CAUTION:** Be careful not to break any of the retainer tabs.

6. Install "U" shaped brush retainer clip over brush holder that has brush lead attached to circuit breaker (fig. 30).
7. Holding the opposite brush from that retained in Step 6, carefully lift the brush holder off the mounting tabs far enough to clear the armature commutator (fig. 31).
8. Allow the brush, held in Step 7, to move out of its holder. Remove the brush spring and lift the brush holder off the armature shaft.

**Armature**

**Removal**

1. Follow Steps 1 thru 8 under brush plate and circuit breaker removal.
2. Lift armature out of case and field assembly.
3. If armature is being replaced, remove thrust ball

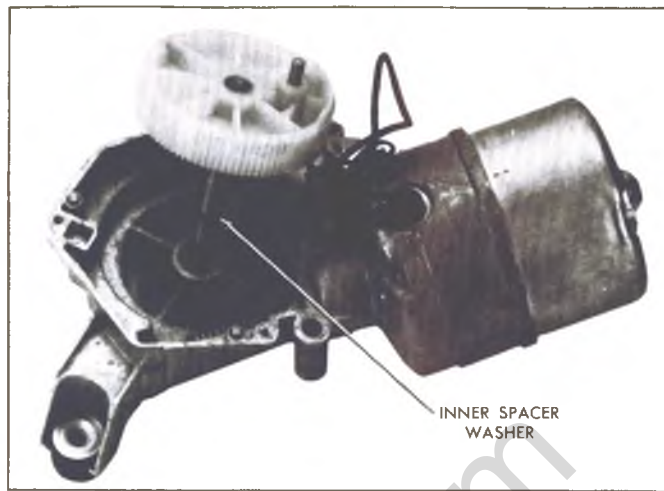

Fig. 28--Drive Gear Removal



Fig. 29--Wiper Motor Separation

from end of defective armature shaft and install it in new armature.

**NOTE:** Thrust ball may be easily removed with a magnet.

**Case and Field Assembly**

**Removal**

1. Remove brush plate and armature.
2. The end case and field assembly is serviced as a unit. To free the field and case assembly, cut the solid black plastic insulation and black with pink

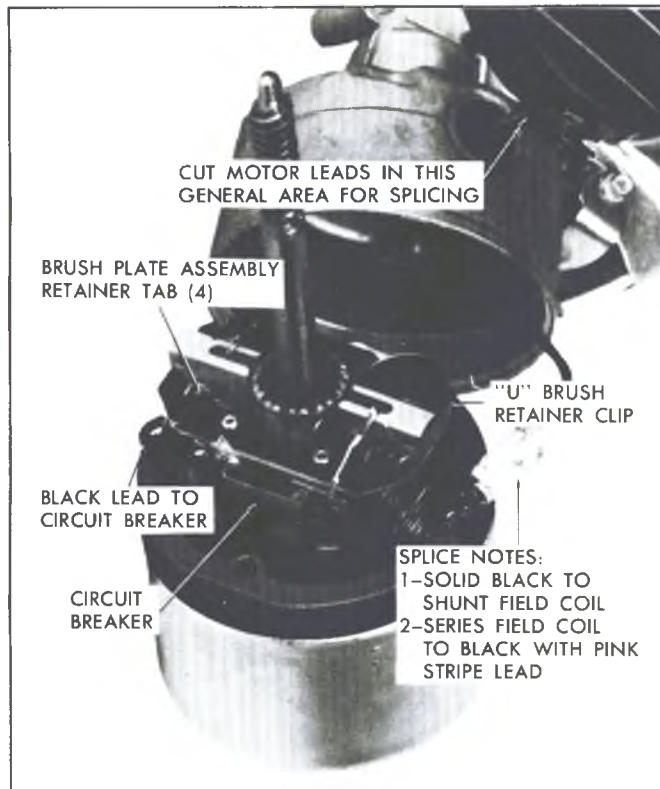

Fig. 30-Circuit Breaker

stripe leads in a location convenient for splicing—preferably near the wiper terminal board. Refer to Figure 30 for splicing location.

3. Remove steel thrust plate and rubber disc from case bearing as required.

### MOTOR ASSEMBLY

1. If new field and case assembly is being installed, splice the black and black with pink stripe leads of the new field with the corresponding leads of the wiper terminal board.
2. Install the rubber thrust disc, steel thrust disc and felt lubricating washer in the case assembly bearing in order indicated.
3. Lubricate end of armature shaft that fits in case bearing. Next, install thrust ball in end of shaft.
4. Assemble armature in the case and field assembly (fig. 32).
5. Position the partially assembled brush plate (fig. 33) over the armature shaft far enough to allow assembly of the remaining brush in its brush holder, then position the brush plate on the mounting tabs in the position shown in Figure 30.

NOTE: Circuit breaker should be opposite field cross over splice connections (Figure 30).

6. Center the brush plate mounting holes over the



Fig. 31-Removing Brush Holder



Fig. 32-Armature Installation

mounting tabs and bend the tabs toward the brush holders as required to secure the brush plate in position.

**CAUTION:** Be sure tabs are centered in brush plate mounting holes.

7. Remove brush retainer clips and resolder black cotton covered lead to circuit breaker (fig. 30).
8. If new case and field assembly is used, scribe a line

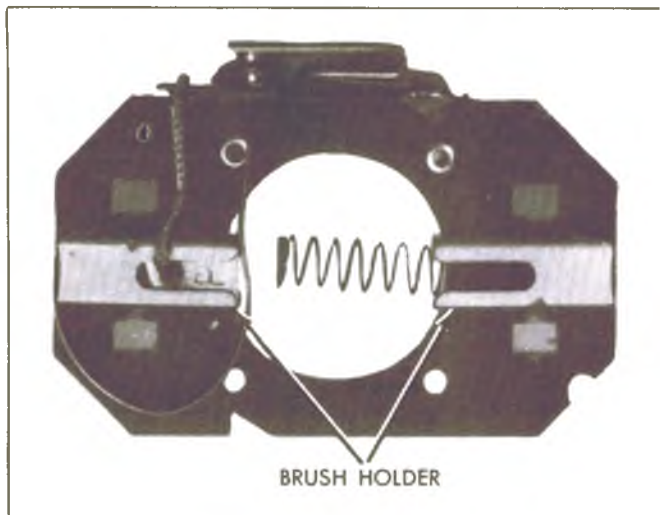

Fig. 33-Brush Plate Assembly

on it in the same location as the one scribed on the old case. This will insure proper alignment of the new case with the scribed line made on the housing (Step 1 under Brush Plate Removal).

9. Position armature worm shaft inside the housing and, using the scribed reference marks, line up as near as possible the case and field assembly with the housing.
10. Maintaining the armature in its assembled position in the case, start the armature worm shaft through the field and housing bearing until it starts to mesh with the worm gear. At the same time, carefully pull the excess black and black and pink stripe leads through the housing grommet.
 

**CAUTION:** *It may be necessary at this point to rotate armature slightly before the armature worm will engage with worm gear teeth.*
11. Rotate the case as required to align the bolt holes in the case with those in the housing.
12. Secure the case to the housing with the two tie bolts.
13. Adjust armature end-play as described under "Wiper Adjustments".

## WIPER ADJUSTMENTS

### Armature End-Play

Loosen adjusting screw locknut (Figure 26) and tighten the adjusting screw until finger tight, tighten locknut.

### Gear Assembly End-Play

Add end-play washers as required to obtain .005" minimum end-play (Figure 26).

## WASHER PUMP

The washer pump and/or valve assembly may be

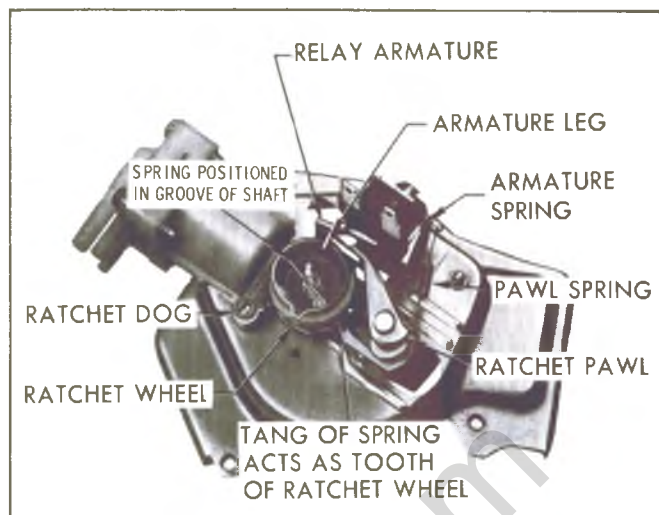

Fig. 34-Washer Pump Assembly

removed from the wiper assembly as a unit; therefore, it is not necessary to remove the wiper assembly from the vehicle if only the washer pump and/or valve assembly requires service.

When the pump is removed from the wiper assembly, all working parts are readily accessible and may easily be serviced as necessary (fig. 34). A cross-section of the washer pump valve assembly is shown in Figure 35.

### Replacement

1. Raise vehicle hood and disconnect ground cable from battery.
2. **G Models** - Remove left heater duct attached to engine shroud, for access.
3. Disconnect washer hoses and electrical connections from assembly.
4. Remove three screws securing washer pump and cover to wiper assembly. Remove pump from wiper gear box.
5. To install, reverse Steps 1-4 above.

## Pump Valve

### Replacement

1. **G Models** - Remove the washer pump as outlined above.
- C-K Models** - Raise hood. Disconnect washer hoses and electrical connections from assembly.
2. Remove the four screws that attach the valve assembly to the pump housing.

**CAUTION:** *During re-assembly be sure gasket between housing and valve plate is properly positioned in the housing and valve plate grooves. Also be sure triple "O" ring is properly installed between valve and pipe assembly.*

3. To install, reverse removal procedure.

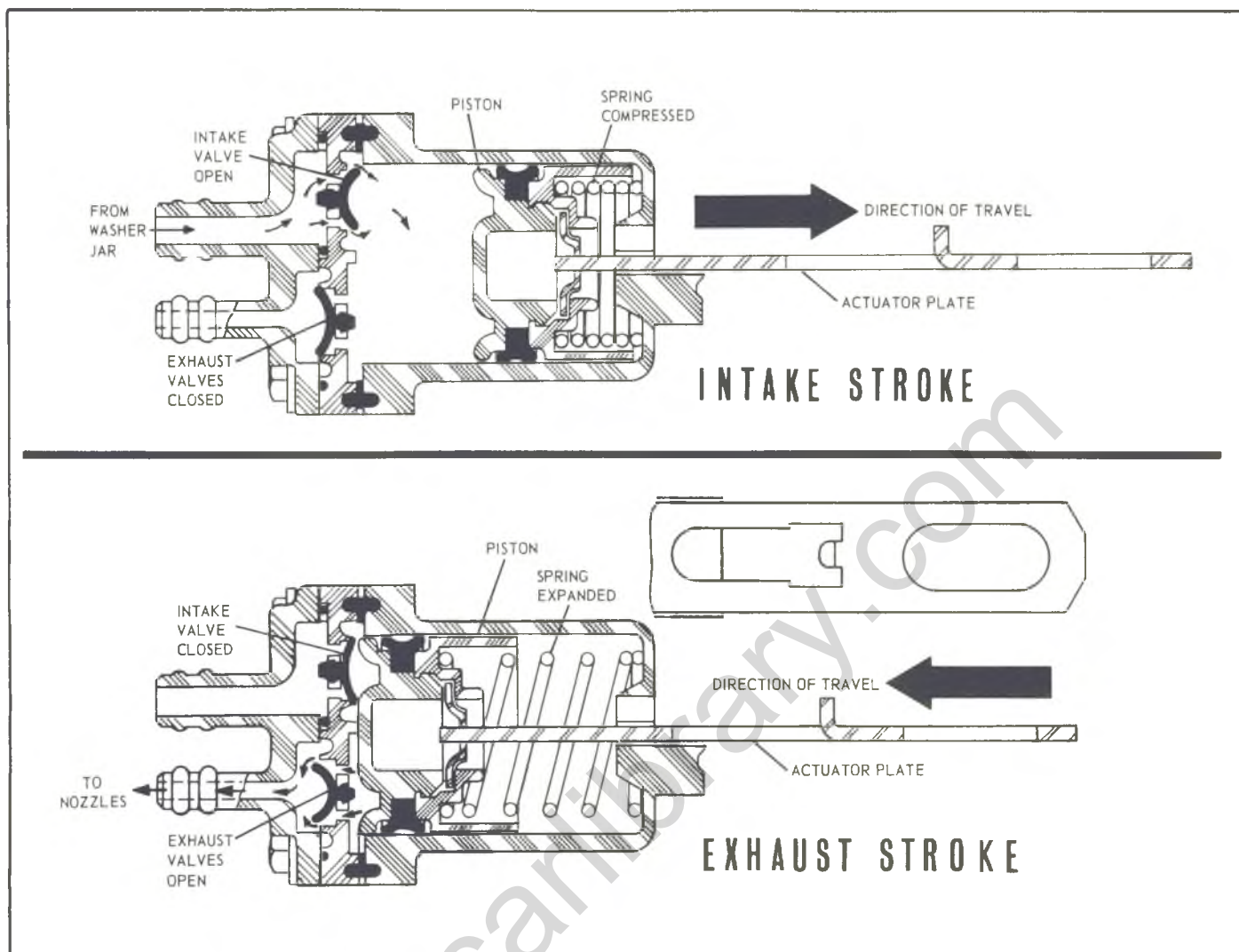

Fig. 35-Cross Section of Windshield Washer Pump Valve Assembly

## DIAGNOSIS

### WIPER - ON VEHICLE

Troubleshooting with wiper installed on the vehicle consists of two basic steps: (A) Preliminary inspection and (B) Operating wiper independent of vehicle wiring and dash switch.

#### Preliminary Inspection Procedure

- A. Preliminary Inspection - Check the following items:
1. Body wiring securely connected to wiper unit and dash switch.
  2. Wiper ground connection to vehicle chassis.
  3. Dash switch is mounted securely.
  4. Fuse.

5. With ignition switch "ON", there should be 12 volts at center terminal (No. 2) of wiper connector body. Refer to Figure 36 for #2 terminal location.

- B. To determine if wiper is cause of trouble, disconnect existing harness from wiper and connect jumper leads to wiper terminals as shown in Figure 36. Try operating wiper in LO and HI speeds. Also check if wiper will shut off properly (blades in park position).

If wiper operates correctly, trouble must be in wiring harness or dash switch. Refer to TROUBLE CHART. If wiper fails to operate correctly, remove wiper and check it per instructions in TROUBLE CHART - WIPER DETACHED.

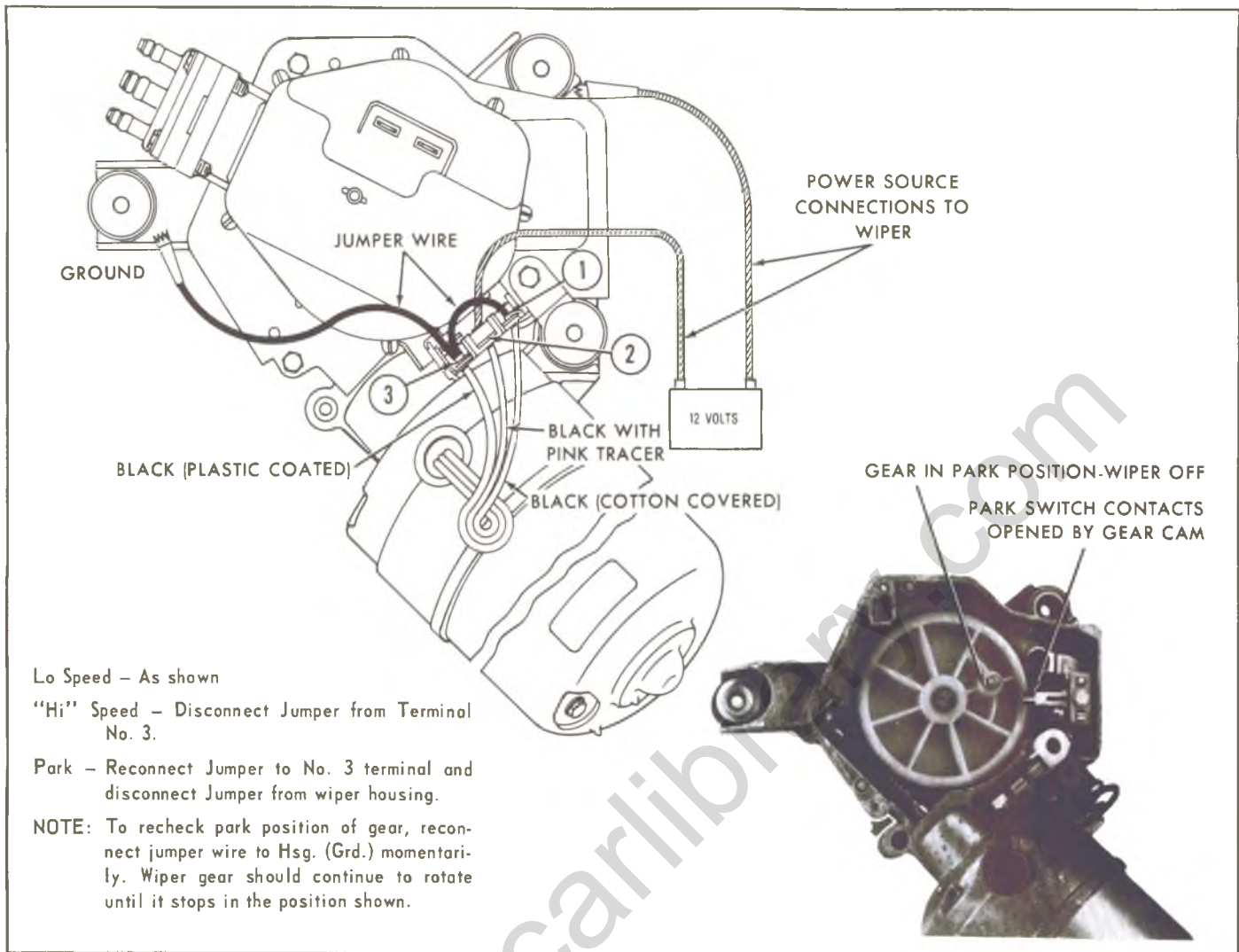

Fig. 36--Wiper Motor Diagnosis Diagram

**WIPER - OFF VEHICLE**

Connect Ammeter (0-30 amps), Power Source and

Jumper wires to wiper as shown in Figure 36. Observe current draw, determine type of trouble that exists and refer to the TROUBLE CHART - WIPER DETACHED.

TROUBLE CHART	
Wiper Performs Correctly in Step "B" But ORIGINAL TROUBLE Was	POSSIBLE CAUSE
1 — Wiper inoperative	<ul style="list-style-type: none"> <li>— No voltage supply at wiper (Blown fuse or open in wire that connects to No. 2 wiper terminal.)</li> <li>— Defective Dash Switch</li> <li>— Wire from Wiper Terminal No. 1 to dash switch open.</li> </ul>
2 — Wiper would not shut off but had: (a) Both LO and HI speeds  (b) LO speed only  (c) HI speed only	<ul style="list-style-type: none"> <li>(a) Wire from wiper terminal 1 to dash switch grounded.</li> <li>(b) Wire from wiper terminal No. 3 to dash switch grounded.</li> <li>(c) Wire from wiper terminal No. 3 to dash switch open.</li> </ul>
3 — Wiper had "HI" speed only	See item 2 (c) above
4 — Wiper had "LO" speed only	See item 2 (b) above
5 — Intermittent Operation	Loose dash switch mounting. Defective dash switch.

TROUBLE CHART – WIPER DETACHED

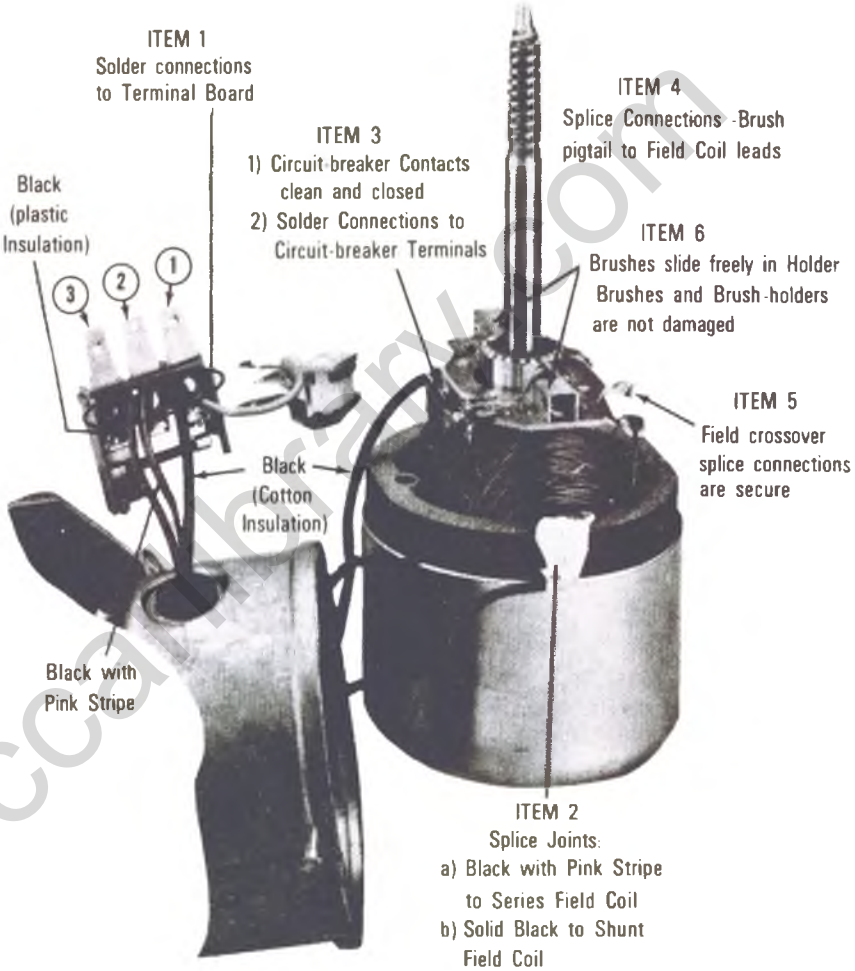
Trouble Description	Check the items shown in the views opposite trouble description
<p>(1) <u>Wiper Inoperative</u> and</p> <p>(a) Ammeter Reading – 0 Amp. Check items: 1, 2(a), 4 and 5</p> <p>(b) Ammeter Reading – 2.0–3.0 Amps Check items: 1, 3, 4, 6</p> <p>(c) Ammeter Reading – 20 + Amps Check for condition that will stall wiper, such as broken gear or locked armature.</p>	 <p>ITEM 1 Solder connections to Terminal Board</p> <p>ITEM 2 Splice Joints: a) Black with Pink Stripe to Series Field Coil b) Solid Black to Shunt Field Coil</p> <p>ITEM 3 1) Circuit-breaker Contacts clean and closed 2) Solder Connections to Circuit-breaker Terminals</p> <p>ITEM 4 Splice Connections - Brush pigtail to Field Coil leads</p> <p>ITEM 5 Field crossover splice connections are secure</p> <p>ITEM 6 Brushes slide freely in Holder Brushes and Brush-holders are not damaged</p> <p>Black (plastic Insulation)</p> <p>Black (Cotton Insulation)</p> <p>Black with Pink Stripe</p>

## TROUBLE CHART – WIPER DETACHED (CONT.)

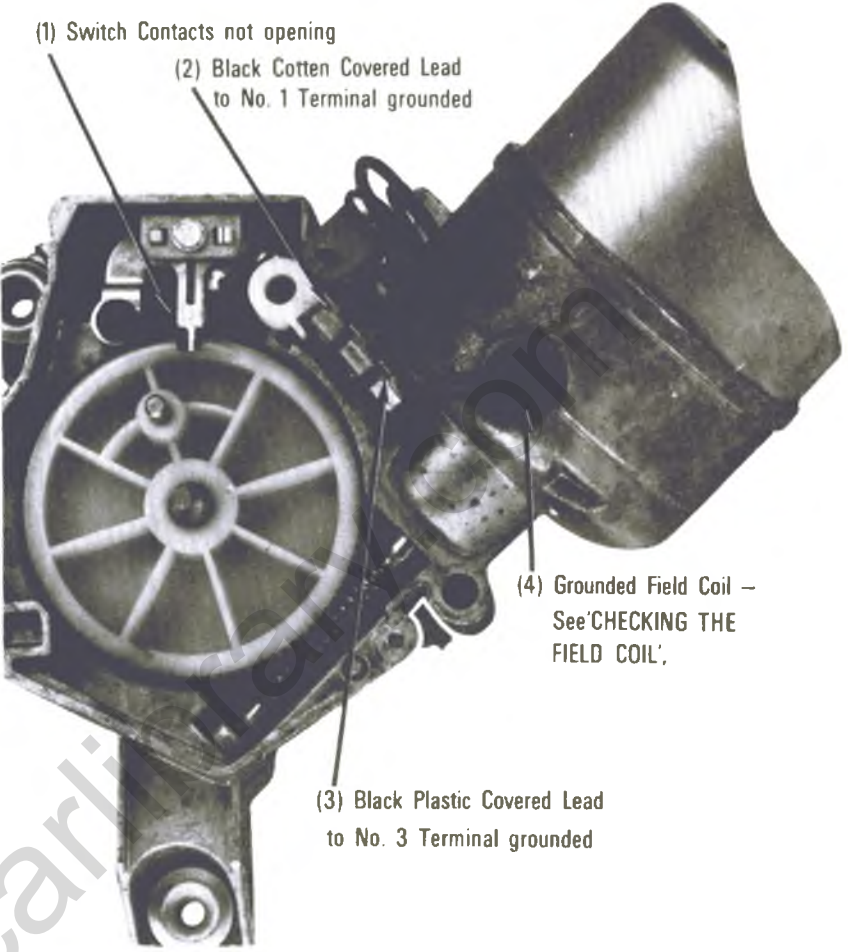
Trouble Description	Check Items shown in views opposite trouble description
<p>(2) <u>Wiper will not shut off</u> and</p> <p>(a) Wiper has both LO and HI Speeds. Check Items (1) and (2).</p> <p>(b) Wiper has LO Speed Only. Check Items (3) and (4).</p> <p>(c) Wiper has HI Speed Only. (Shunt field circuit open) Refer to trouble condition "Wiper Inoperative" and check Items 1, 2 (b), 4 and 5.</p>	 <p>(1) Switch Contacts not opening</p> <p>(2) Black Cotton Covered Lead to No. 1 Terminal grounded</p> <p>(3) Black Plastic Covered Lead to No. 3 Terminal grounded</p> <p>(4) Grounded Field Coil – See 'CHECKING THE FIELD COIL'.</p>
<p>(3) <u>Wiper has "HI" Speed Only</u></p>	<p>Refer to view opposite trouble condition "Wiper Inoperative" and check Items 1, 2 (b), 4 and 5.</p>
<p>(4) <u>Wiper has "LO" Speed Only</u></p>	<p>See Trouble Description 2 (b).</p>
<p>(5) <u>Wiper Gear and/or crank arm does not park correctly.</u> Wiper gear and/or crank arm stops rotating immediately when wiper motor is shut off.</p>	<p>Check for bent, damaged or dirty park switch contacts. See Item (1) in view opposite Trouble Description No. 2 "Wiper will not shut "Off".</p>
<p>(6) <u>Wiper Speed Excessive in Hi Speed Mode</u> (Crank arm or gear rotation exceeds 80 RPM)</p>	<p>Open resistor on back of wiper terminal board.</p>



TROUBLE CHART – WIPER DETACHED (CONT.)

Trouble Description	Check items shown in view opposite trouble description.
<p>(7) Intermittent Operation:</p> <p>(a) Current Draw Normal (3.5 – 5.0 amps.)</p> <p>(b) Current Draw – 6 – 8 amps. (Wiper runs slow and is noisy.)</p>	<p>(1) Check for loose splice joints and/or solder joints. Refer to view opposite trouble description (wiper Inop). If items check out, a defective circuit breaker is indicated.</p> <p>(1) Check for shorted or grounded armature.</p> <p>(2) Check armature end play (.002" – .003" Normal)</p> <p>(3) Check gear shaft end play (.005" Max.)</p>

CHECKING THE ARMATURE AND FIELD COIL ASSEMBLY

Field testing the armature and continuity of field coils consists of using a test light similar to that shown in Figure A.

Disassemble Motor as required to gain access to the field and armature assemblies.

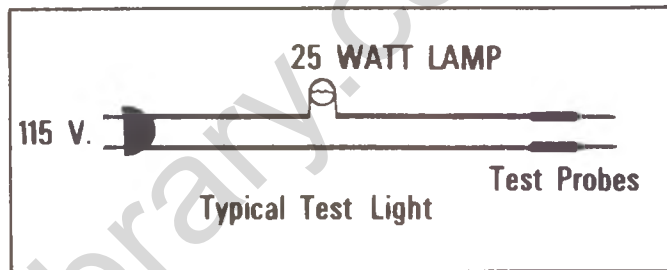

FIGURE A

Armature Checks:

Grounded—Touch test light probes to armature lamina and commutator. If armature is grounded, the lamp will light.

Open – A bar to bar check with the test light will indicate an open armature (Fig. B). If lamp does not light between any two adjacent commutator bars, an open armature is indicated.

Shorted – Test armature on growler for shorted condition.

Field Coil Checks:

IMPORTANT: Insulate brushes from armature commutator. A thin piece of paper will be adequate.

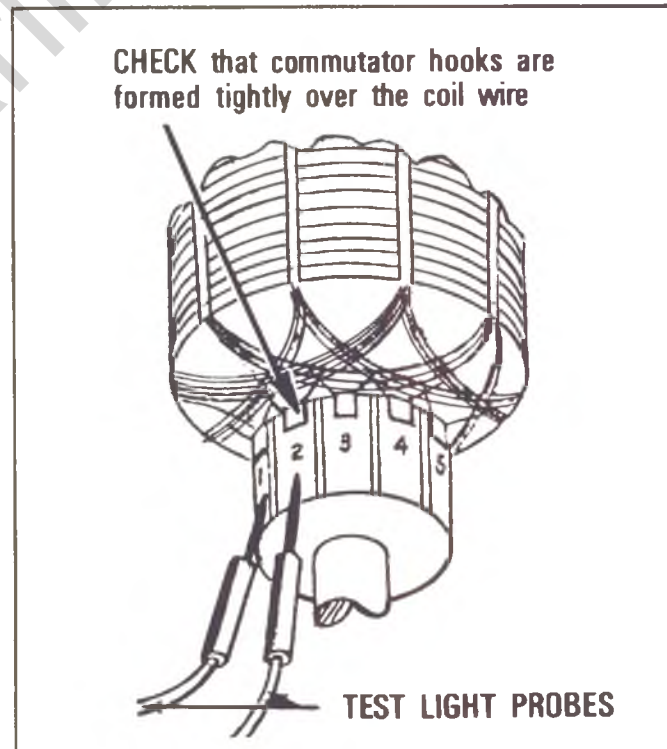

FIGURE B

## CHECKING THE ARMATURE AND FIELD ASSEMBLY (CONT.)

- Open Check** Connect test light to following points. Refer to Figure C .
- Shunt Field:** Brush lead "A" and black wire terminal (No. 3) on wiper terminal board. If lamp fails to light, check splice joints — Items 2, 4 and 5 in Trouble Chart opposite wiper inoperative.
- Series Field:** Brush lead "A" and No. 2 terminal on wiper terminal board Figure C . If lamp fails to light, check splice joints — Items 2, 4 and 5 in Trouble Chart opposite wiper inoperative.
- Ground Check** Connect test light to field lamina and wiper terminal board, terminals 2 and 3. (Be sure End Cap and Field Lamina are not touching wiper gear casting.)

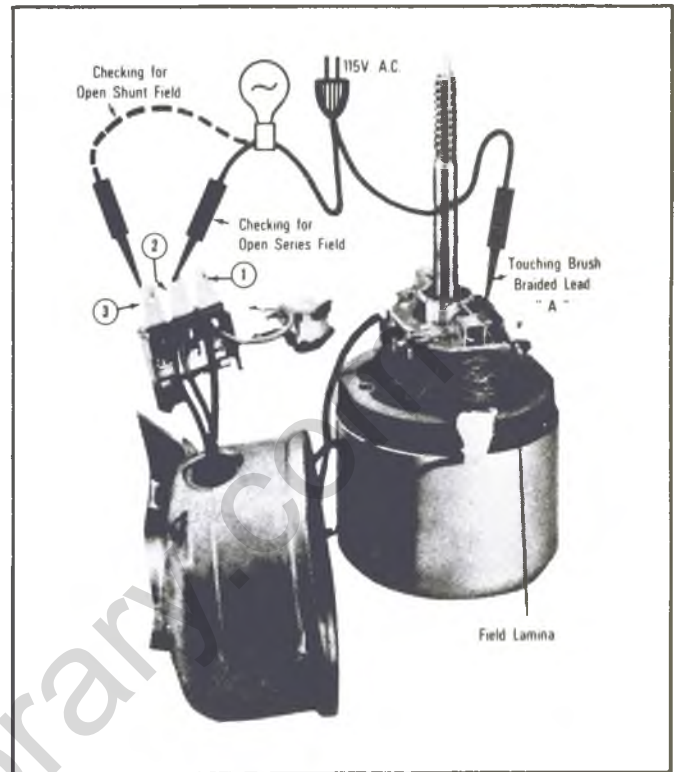

FIGURE C

## DIAGNOSIS - WASHER SYSTEM

CONDITION	APPARENT CAUSE	CORRECTION
1. Washer inoperative	<p>A. Inadequate quantity of washer solution</p> <p>B. Hoses damaged or loose</p> <p>C. Plugged screen at end of jar cover hose</p> <p>D. Loose electrical connection to washer pump or wiper switch</p> <p>E. Open circuit in feed wire to pump solenoid coil</p> <p>F. Wiper switch defective</p> <p>G. Pump solenoid coil defective</p> <p>H. Washer nozzles plugged</p> <p>I. Ratchet wheel tooth missing</p> <p>J. Ratchet pawl spring missing</p> <p>K. Defective pump valve assembly</p>	<p>A. Add washer solution</p> <p>B. Cut short length to insure air tight connection or replace hose</p> <p>C. Clean screen</p> <p>D. Check electrical connection and repair if necessary</p> <p>E. Locate open circuit and repair</p> <p>F. Replace wiper switch</p> <p>G. Replace solenoid</p> <p>H. Clean washer nozzles</p> <p>I. Replace ratchet wheel</p> <p>J. Replace ratchet pawl spring</p> <p>K. Replace pump valve assembly</p>
2. Washer pumps continuously when wipers are operating	<p>A. Grounded wire from pump solenoid to switch</p> <p>B. Wiper Switch Defective</p> <p>C. Ratchet wheel tooth missing</p> <p>D. Ratchet wheel dog broken or not contacting ratchet wheel teeth</p> <p>E. Lock-out tang broken or bent on piston actuating plate</p>	<p>A. Locate grounded wire and repair</p> <p>B. Replace wiper switch</p> <p>C. Replace ratchet wheel</p> <p>D. Replace or repair ratchet wheel dog</p> <p>E. Replace piston actuating plate</p>

# WINDSHIELD WIPER AND WASHER P MODELS

## INDEX

General Description .....	12-33
Theory of Operation.....	12-33
Service Operations.....	12-34
Wiper Motor.....	12-34
Windshield Washer.....	12-36
Diagnosis.....	12-39

## GENERAL DESCRIPTION

The system consists of a compound wound rectangular-shaped motor attached to a gear box containing a parking switch in addition to the gear train. The gear train consists of a motor armature helical gearshaft

which drives an intermediate gear and pinion assembly. The pinion gear of the intermediate gear and pinion drives an output gear and shaft assembly.

## THEORY OF OPERATION

Turning the wiper switch to the LO speed position completes the circuits from the wiper terminals 1 and 3 to ground. Current then flows from the battery via wiper terminal No. 2 through the series field and divides; (1) part passes through the armature to ground via wiper terminal No. 1 to the wiper switch and (2) the second part passes through the shunt field to ground through wiper terminal No. 3 to the wiper switch (fig. 37).

**NOTE:** The wiper switch must be securely grounded to body metal.

Moving the wiper switch to the HI speed position opens the shunt field circuit to ground at the switch. However, the shunt field is connected to a 20 ohm resistor which is connected across wiper terminals 1 and 3. The shunt field

current then flows via terminal No. 3 through the resistor to terminal No. 1 to the switch, to ground (fig. 38).

The parking circuit covers that portion of wiper operation when the wiper switch is turned "off" and the wiper blades have not reached the park position.

When the wiper blades are not in the normal park position, the parking switch contacts are still closed. The wiper will continue to operate until the wiper output gear is turned to a position where its cam opens the park switch. Referring to Figure 39, it can be seen that the wiper motor circuits are completed to ground through the parking switch.

**NOTE:** The wiper motor must be securely grounded to body metal.

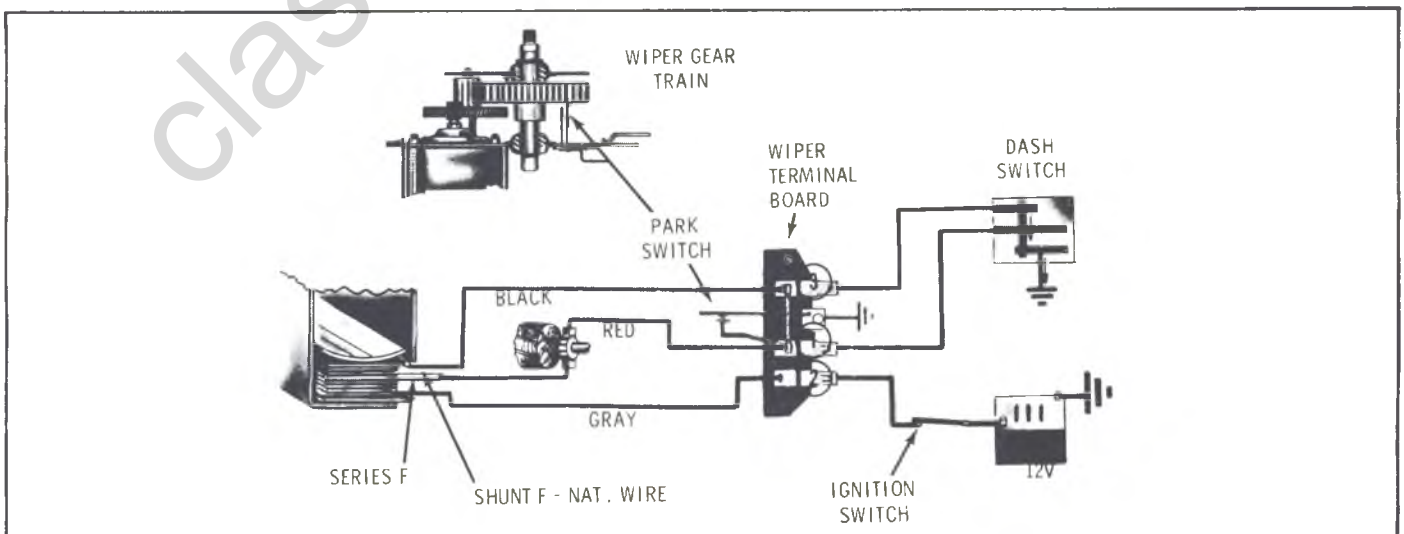

Fig. 37--LO Speed Circuit

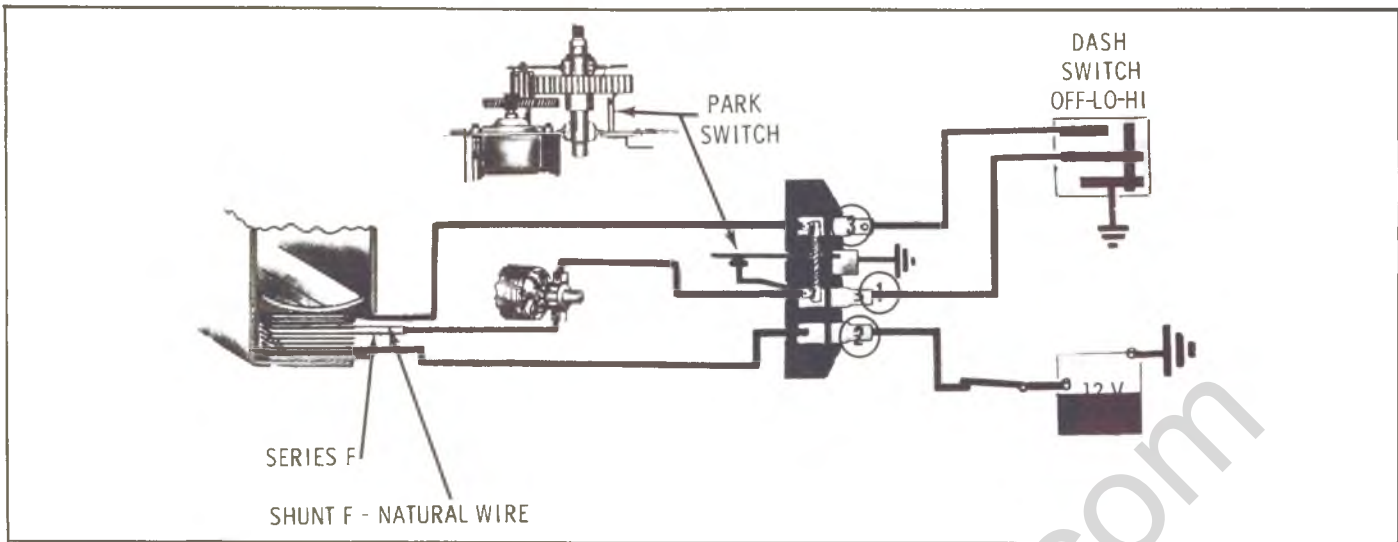

Fig. 38--HI Speed Circuit

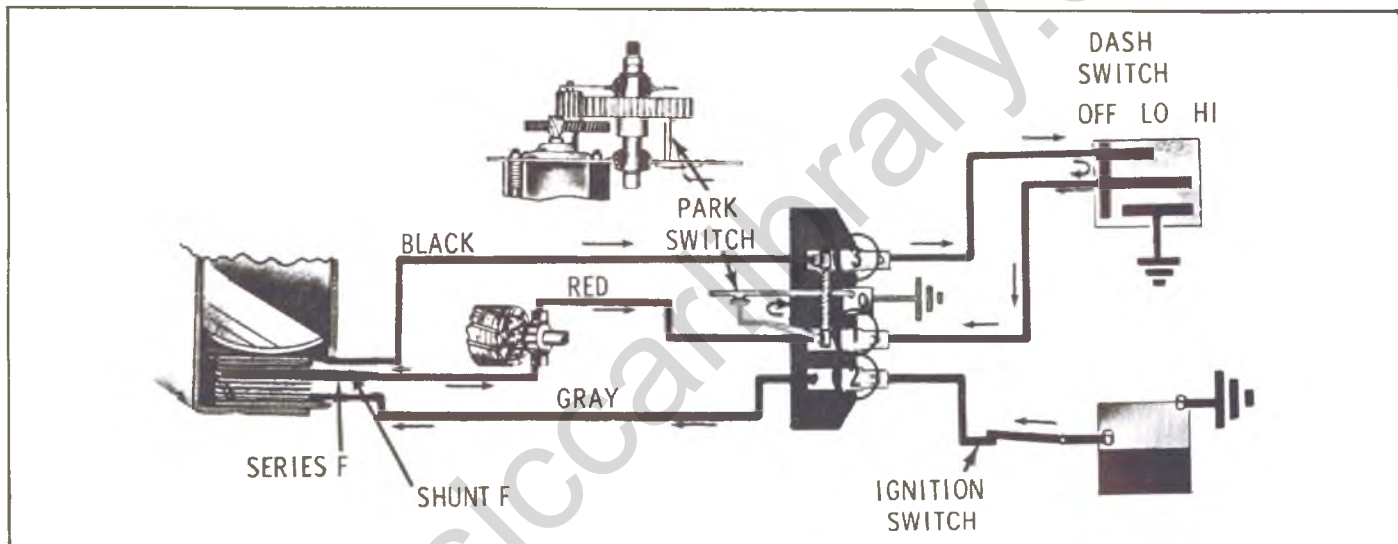

Fig. 39--PARKING Circuit

The shunt field circuit is completed from terminal No. 3 via the switch to terminal No. 1 through the parking switch to ground. The series field and armature circuit is also completed from terminal No. 1 through the parking switch to ground.

NOTE: The shunt field is connected direct to

ground, by-passing the resistor. This results in LO speed operation during the parking operation.

When the output gear cam opens the park switch contacts, the wiper is OFF.

## SERVICE OPERATIONS

### WIPER MOTOR

Wiper motor replacement procedures are not included here since installation is performed by the individual body manufacturers; however, disassembly of the unit will be covered.

### Disassembly (Fig. 40)

#### Gear Box

1. Remove the two washer pump mounting screws and

lift pump off washer.

2. Remove washer pump drive cam as required (figs. 43 and 44). The cam is pressed on the shaft but can be wedged off by using two screwdrivers between cam and plate.
3. Clamp crank arm in a vise and remove crank arm retaining nut.

**CAUTION:** Failure to clamp crank arm may result in stripping of wiper gears.

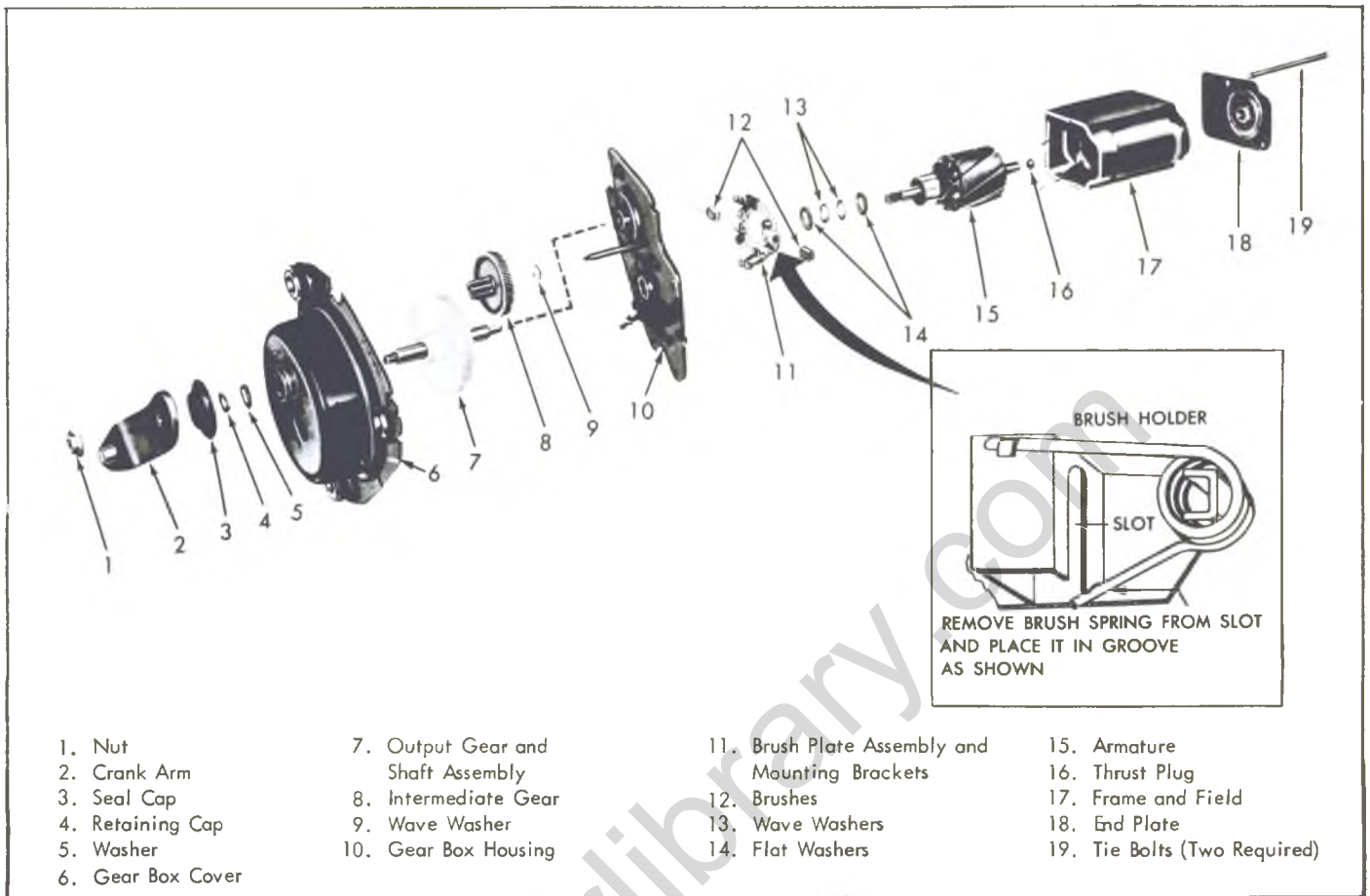

Fig. 40-Wiper Motor and Gear Box Assembly

4. Remove crank arm, seal cap, retaining ring, and end-play washers.

NOTE: Seal cap should be cleaned and repacked with a waterproof grease before reassembly.

5. Drill out gear box cover retaining rivets, remove cover from gear train.

NOTE: Screws, nuts and lockwashers for reassembling cover to wiper are contained in the service repair package.

6. Remove output gear and shaft assembly, then slide intermediate gear and pinion assembly off shaft.

7. If necessary, remove terminal board and park switch assembly as follows:

- a. Unsolder motor leads from terminals. Code motor leads.
- b. Drill out rivets securing terminal board and park switch ground strap to mounting plate.

NOTE: Screws, nuts and washers for attaching a replacement terminal board park switch assembly are included with the replacement assembly.

### Motor

1. Follow Steps 1 through 7b under gear box disassembly.
2. Remove motor through bolts, tap motor frame lightly, and remove motor from mounting plate.
3. Remove brush spring tension (fig. 40), slide armature and end plate from motor frame. Pull end plate from armature.

NOTE: Thrust plug located between armature shaft and end plate.

4. Remove end play adjusting washers from armature, noting arrangement for proper reinstallation.

### Inspection

Check and inspect all parts for wear; replace as necessary. All parts can be replaced individually except motor frame and field, which is serviced as an assembly. Service kits also provide screws, nuts and washers to replace gear cover and terminal board rivets.

### Assembly

Refer to Figure 40 for exploded view of motor and gear train.

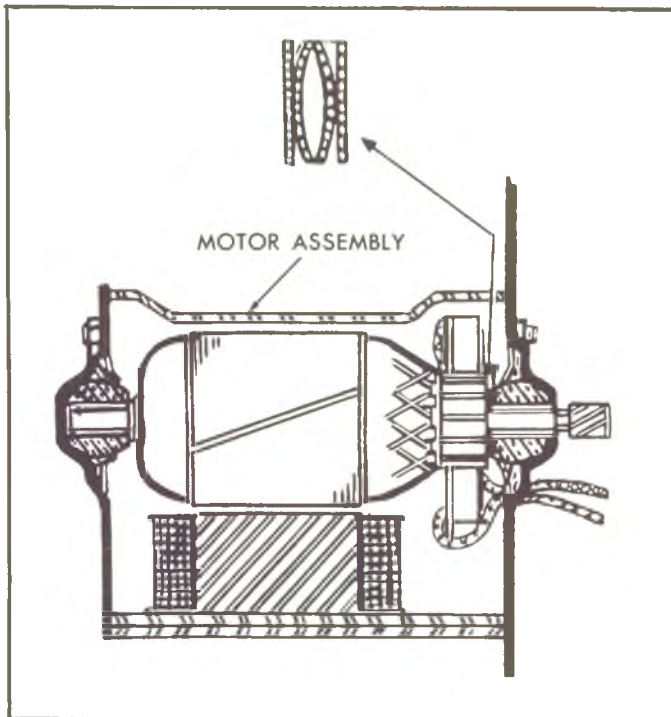

Fig. 41--End Play Wave Washer Installation

**Motor**

Reassemble motor using reverse of disassembly procedure.

NOTE: Armature end play is controlled by end play washers. See Figure 41 for proper assembly of end play washers. Lubricate armature shaft bushings with light machine oil.

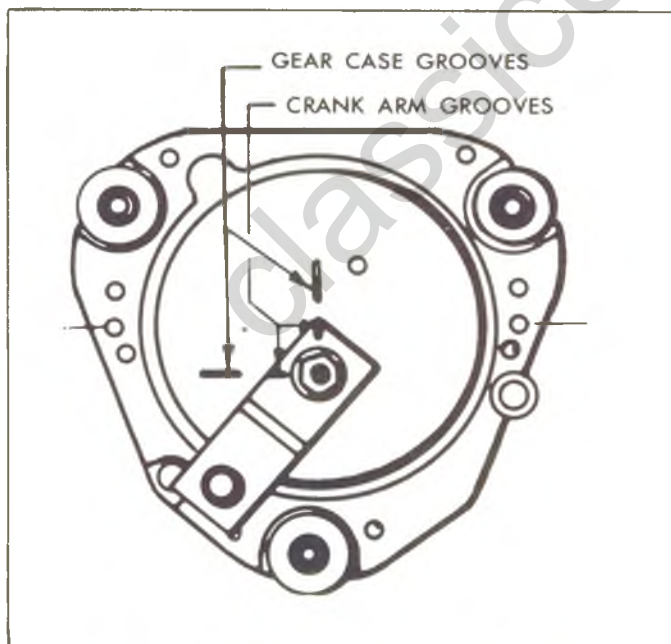

Fig. 42--Wiper Motor Crank Arm in Park Position

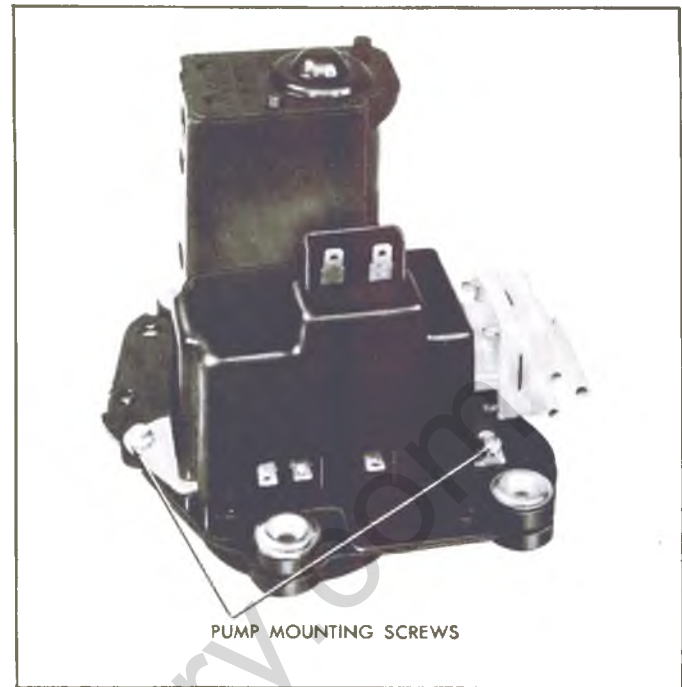

Fig. 43--Washer Pump Attaching Screws

**Gear Box**

1. Assemble gear box using reverse of disassembly procedure.

NOTE: Lubricate gear teeth with Delco Cam and Ball Bearing lubricant (or equivalent). Be sure cover is properly located over dowel pins and be sure to reinstall ground strap.

2. Place wiper in park position and install crank arm on output shaft, rotate crank so alignment marks line up with those on cover (fig. 42).
3. Replace retaining nut, place crank arm in vise, tighten retaining nut.

**WINDSHIELD WASHER**

The positive displacement washer pump used on the two-speed non-depressed park wipers (fig. 43) use a pump mechanism consisting of a piston, piston spring and valve arrangement driven by a (4) lobe cam, and follower assembly (fig. 45). The cam is attached to one shaft of the wiper motor output gear (fig. 44). Programming is accomplished electrically and mechanically by a relay assembly and ratchet wheel arrangement.

**Replacement**

1. Disconnect battery ground cable.
2. Remove two (2) pump mounting bolts.
3. Remove washer pump assembly.



Fig. 44--Washer Pump Drive Cam

4. To install reverse Steps 1-3 above.

**CAUTION:** Install washer multiplug harness connector with battery lead on terminal with no tang (fig. 43). Incorrect installation of connector will result in direct ground and destroy wiper motor fuse.

#### Disassembly-Assembly (Figures 46-49)

1. Remove washer pump cover by squeezing.



Fig. 45--Washer Pump Drive Cam and Actuator

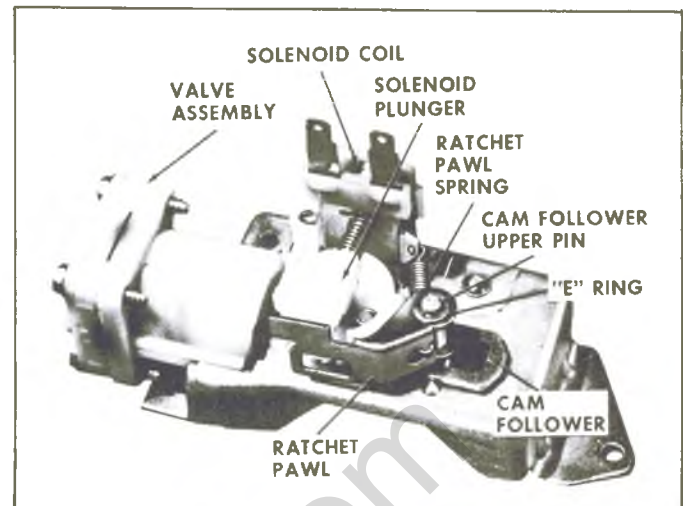

Fig. 46--Washer Pump Mechanism

2. Solenoid assembly - ratchet dog.
  - a. Remove the ratchet dog retaining screw. Hold the spring loaded solenoid plunger in position and carefully lift the solenoid assembly and ratchet dog off the frame of the pump.
  - b. Separate the ratchet dog from solenoid mounting plate as required.
3. Ratchet pawl.
  - a. Disconnect ratchet pawl spring.
  - b. Remove ratchet pawl retaining ring and slide ratchet pawl off cam follower shaft.
4. Ratchet wheel.
  - a. Follow Step 1 under solenoid - ratchet dog disassembly.

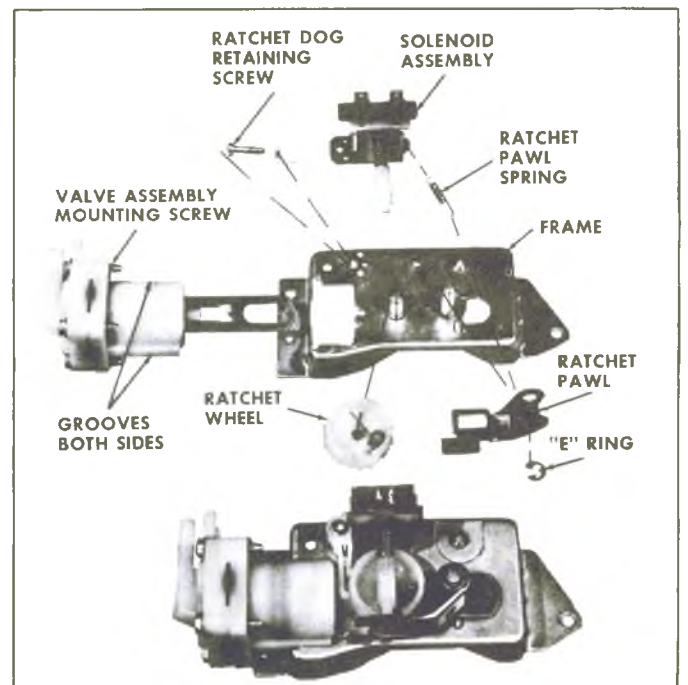

Fig. 47--Washer Pump-Exploded View





Fig. 48--Releasing Pump From Lockout Position

- b. Move ratchet wheel spring out of shaft groove and slide ratchet wheel off its shaft.
5. Pump and actuator plate assembly.

- a. Remove solenoid assembly - ratchet dog, ratchet pawl and ratchet wheel as outlined in their respective procedures.
  - b. To separate the pump and pump actuator plate from the frame, pull the pump housing in the direction of the arrow until the grooves in the housing clear the frame. Then remove the actuator plate from the ratchet wheel and cam follower shafts.
6. Valve assembly.
- a. Remove the four (4) screws that attach the valve assembly to the pump housing.

**CAUTION:** During assembly, be sure gasket between housing and valve plate is properly positioned in the housing and valve plate grooves. Also be sure triple "O" ring is properly installed between valve body and pipe assembly.

- 7. To assemble washer unit, reverse above procedures.

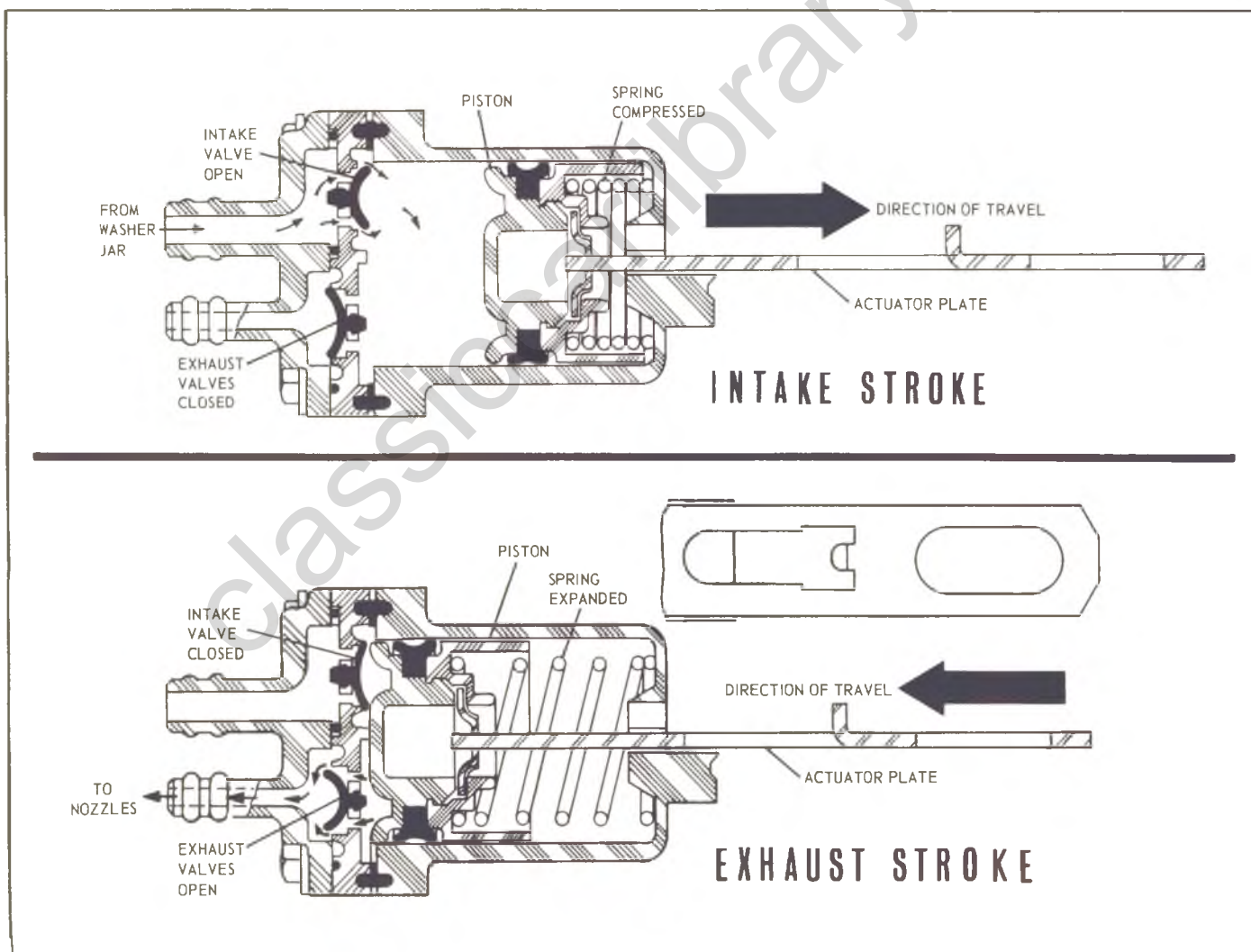

Fig. 49--Cross Section of Windshield Washer Pump Valve

## DIAGNOSIS

## WIPER - ON VEHICLE

1. Inspect for the following items:
  - a. Wiring harness is securely connected to wiper and switch.
  - b. Wiper motor is securely grounded to body.
  - c. Wiper switch is securely mounted and grounded.
  - d. Check fuse.
2. If items in Step 1 check out, try operating wiper in both "LO" and "HI" speeds, then turn wiper off (blades should return to park position). If wiper fails to operate correctly, proceed to Step 3.
3. Disconnect wiring harness from wiper and try operating wiper as shown in Figure 50.
  - a. If wiper operates correctly independently of switch and vehicle wiring, refer to the DIAGNOSIS CHART - WIPER ON VEHICLE.
  - b. If wiper still fails to operate correctly in Step 3, disconnect wiper linkage from motor crankarm and try operating wiper again. If wiper operates correctly independently of linkage, check linkage for cause of wiper malfunction.

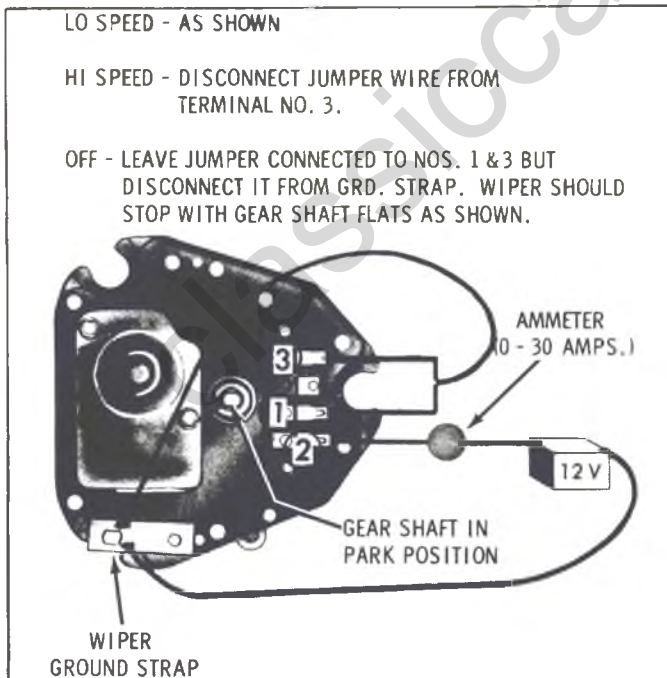

Fig. 50--Jumper Wire Connections

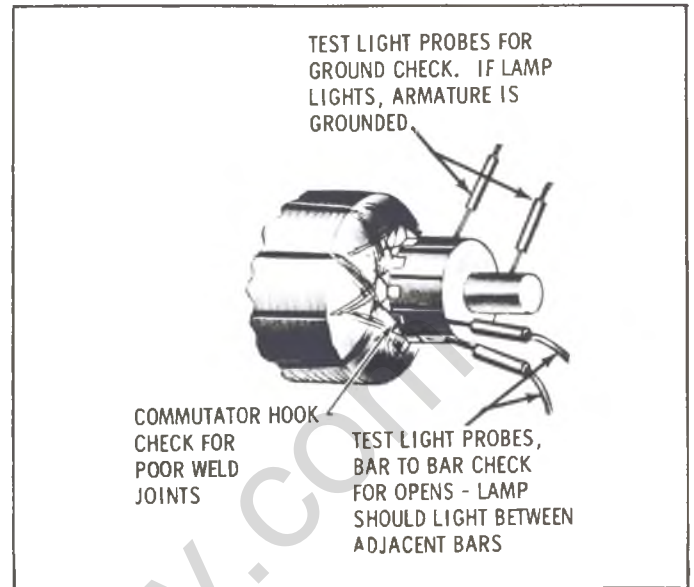

Fig. 51--Checking Armature

- c. If wiper fails to operate correctly independently of linkage, remove wiper motor from vehicle and refer to DIAGNOSIS CHART-WIPER OFF VEHICLE.

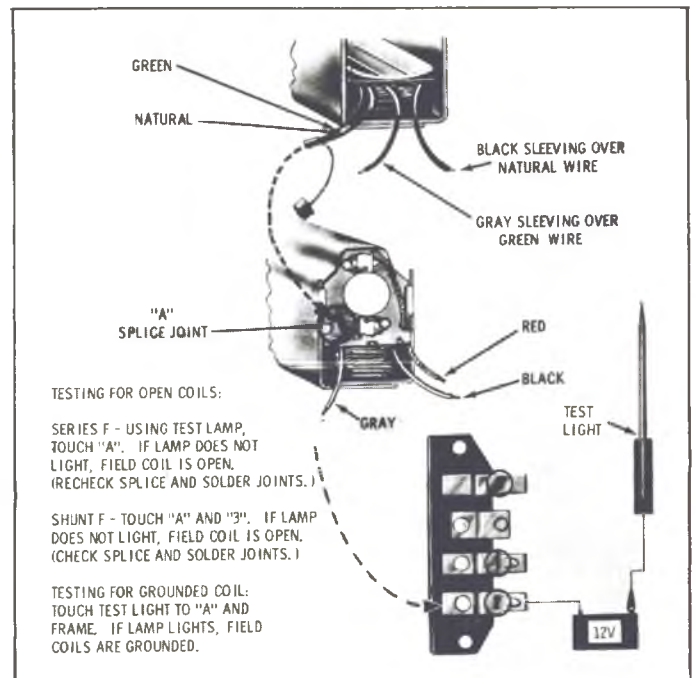

Fig. 52--Testing Field Coils

**DIAGNOSIS - WIPER ON VEHICLE**

NOTE: Ignition switch must be "on" for all electrical tests.

CONDITION	APPARENT CAUSE	CORRECTION
<p>1. Wiper Inoperative or intermittent</p>	<p>A. Blown fuse</p> <p>B. Open circuit in feed wire (No. 2 terminal on wiper motor)</p> <p>C. Loose mounting of wiper switch</p> <p>D. Defective wiper switch</p> <p>E. Open circuit in wire to wiper switch (No. 1 terminal on wiper motor)</p>	<p>A. Locate short circuit and repair. Replace fuse.</p> <p>B. Locate broken wire and repair</p> <p>C. Tighten switch mounting</p> <p>D. Replace switch</p> <p>E. Locate broken wire and repair</p>
<p>2. Wiper will not shut off:</p> <p>A. Wiper has both "Lo" and "Hi" speeds</p> <p>B. Wiper has "Lo" speed only</p> <p>C. Wiper has "Hi" speed only</p>	<p>A. Grounded Wire (No. 1 terminal on wiper motor) to wiper switch</p> <p>A. Defective wiper switch</p> <p>B. Grounded wire (No. 3 terminal on wiper motor) to wiper switch</p> <p>A. Defective wiper switch</p> <p>B. Open circuit in wire (No. 3 terminal on wiper motor) to wiper switch</p>	<p>A. Locate short circuit and repair</p> <p>A. Replace wiper switch</p> <p>B. Locate and repair short circuit</p> <p>A. Replace wiper switch</p> <p>B. Locate and repair broken wire</p>
<p>3. Wiper has "Hi" speed only</p>	<p>A. Open circuit in wire (No. 3 terminal on wiper motor) to wiper switch</p>	<p>A. Locate broken wire and repair</p>
<p>4. Wiper has "Lo" speed only</p>	<p>A. Grounded wire (No. 3 terminal on wiper motor) to wiper switch</p> <p>B. Defective wiper switch</p>	<p>A. Locate short circuit and repair</p> <p>B. Replace wiper switch</p>
<p>5. Blades do not return to full park position</p>	<p>A. Loose wiper ground strap connection</p>	<p>A. Tighten strap connection</p>

## DIAGNOSIS - WIPER OFF VEHICLE

CONDITION	APPARENT CAUSE	CORRECTION
1. Wiper Inoperative or Intermittent	<p>A. Broken or damaged gear train (only if inoperative)</p> <p>B. Poor solder connections at terminal board</p> <p>C. Loose splice joints at brush plate</p> <p>D. Brushes binding in brush holder</p> <p>E. Open circuit in armature</p>	<p>A. Replace gears as required</p> <p>B. Resolder wires at terminals</p> <p>C. Recrimp or solder splice joints</p> <p>D. Clean holder or replace brush, spring or brush plate assembly.</p> <p>E. Replace armature</p>
<p>2. Wiper will not shut-off:</p> <p>A. Wiper has normal "Hi" and "Lo" speed</p> <p>B. Wiper has "Lo" speed only</p> <p>C. Wiper has "Hi" speed only</p>	<p>A. Defective park switch</p> <p>B. Grounded red lead wire</p> <p>A. Grounded shunt field coil</p> <p>B. Grounded black wire</p> <p>A. Open circuit in shunt field coil</p> <p>B. Open circuit in black wire</p>	<p>A. Replace terminal board assembly</p> <p>B. Repair short circuit in red wire</p> <p>A. Replace frame and field assembly</p> <p>B. Repair short circuit in black wire</p> <p>A. Replace frame and field assembly</p> <p>B. Repair broken wire or poor solder connection</p>
3. Wiper shuts off - but not in park position	A. Park switch defective or contacts dirty	A. Replace terminal board assembly or clean contacts
4. "Hi" speed too fast	A. Resistor defective	A. Replace terminal board assembly

## DIAGNOSIS - WASHER SYSTEM

CONDITION	APPARENT CAUSE	CORRECTION
1. Washers inoperative	<p>A. Inadequate quantity of washer solution</p> <p>B. Hoses damaged or loose</p> <p>C. Plugged screen at end of jar cover hose</p> <p>D. Loose electrical connection to washer pump or wiper switch</p> <p>E. Open circuit in feed wire to ratchet relay coil</p> <p>F. Wiper switch defective</p> <p>G. Ratchet relay coil defective</p> <p>H. Washer nozzles plugged</p> <p>I. Ratchet wheel tooth missing</p> <p>J. Ratchet pawl spring missing</p> <p>K. Defective pump valve assembly</p>	<p>A. Add washer solution</p> <p>B. Cut short length off end of hose to insure air tight connection or replace hose</p> <p>C. Clean screen</p> <p>D. Check electrical connections and repair if necessary</p> <p>E. Locate open circuit and repair</p> <p>F. Replace wiper switch</p> <p>G. Replace ratchet relay</p> <p>H. Clean washer nozzles</p> <p>I. Replace ratchet wheel</p> <p>J. Replace ratchet pawl spring</p> <p>K. Replace pump valve assembly</p>
2. Washer pumps continuously when wipers are operating	<p>A. Grounded wire from ratchet relay to switch</p> <p>B. Wiper switch defective</p> <p>C. Ratchet wheel tooth missing</p> <p>D. Ratchet wheel dog broken or not contacting ratchet wheel teeth</p> <p>E. Lock-out tang broken or bent on piston actuating plate</p>	<p>A. Locate grounded wire and repair</p> <p>B. Replace wiper switch</p> <p>C. Replace ratchet wheel</p> <p>D. Replace or repair ratchet wheel dog</p> <p>E. Replace piston actuating plate</p>

# CIRCUIT PROTECTION

## INDEX

General Description .....	12-43
Circuit Breaker .....	12-43
Fuse .....	12-43
Fusible Link .....	12-43
Service Operations	
Fusible Link Replacement.....	12-44
Diagnosis.....	12-44

## GENERAL DESCRIPTION

All electrical circuits are protected against excessive loads which might occur due to shorts or overloads in the wiring system. Such protection is provided by either a circuit breaker, fuse or fusible link. Each of these protective devices are explained below.

### CIRCUIT BREAKER

A circuit breaker is a protective device designed to open the circuit when a current load is in excess of rated breaker capacity. If there is a short or other type of overload condition in the circuit, the excess current will open the circuit breaker and cause it to cycle if it automatically resets, thus, indicating there is something wrong in the system. The circuit breaker will continue to cycle until the trouble is found and corrected. Excessive cycling of the breaker will eventually damage the breaker contacts to the point that replacement of the breaker is necessary.

### FUSE

A common method of protection is to use a fuse in the circuit. Whenever there is an excessive current through the circuit, the fusible element will melt and open the circuit. The disadvantage of using a fuse instead of a circuit breaker is the fuse is a one-time protection and replacement is required.

### FUSIBLE LINK (FIG. 53)

In addition to circuit breakers and fuses, the wiring harness incorporates fusible links to protect the wiring. Links are used rather than a fuse in wiring circuits that are not normally fused, such as the ignition circuit. Chevrolet wiring fusible links are color coded red in the charging and load circuits to match color coding of the circuit they protect. Each link is four gauge sizes smaller than the cable it is designed to protect and are marked on the insulation with wire gauge size because the heavy insulation makes the link appear a heavier gauge than it actually is.

Engine compartment wiring harnesses incorporate several fusible links. The same size wire with special hypalon insulation must be used when replacing a fusible link.

The links are:

1. A molded splice at the starter solenoid "Bat" terminal, 14 gauge red wire. Servicing requires splicing in a new link.
2. A 16 gauge red fusible link is located at junction block to protect all unfused wiring of 12 gauge or larger. The link is molded into the bulkhead connector.
3. The generator warning light and field circuitry (16 gauge wire) is protected by a fusible link (20 gauge red wire) used in the "battery feed to boltage regulator #3 terminal" wire. The link is installed as a molded splice in the circuit at the junction block. Service by splicing in a new 20 gauge wire.
4. The ammeter circuit on G Model trucks is protected

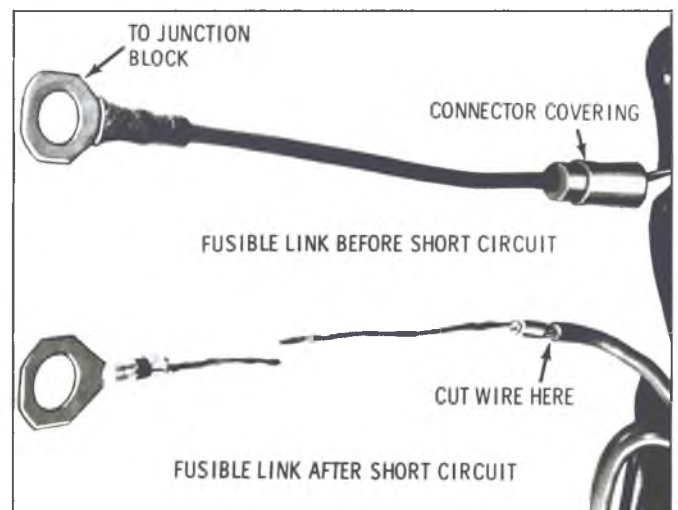

Fig. 53—Fusible Link

by two red 20 gauge wire fusible links installed as molded splices in the circuit at the junction block. On C-K and P trucks, the ammeter circuit uses a

20 gauge wire fusible link in the battery to starter circuit in addition to the two in-line fuses. Service by splicing in new 20 gauge wire.

## SERVICE OPERATIONS

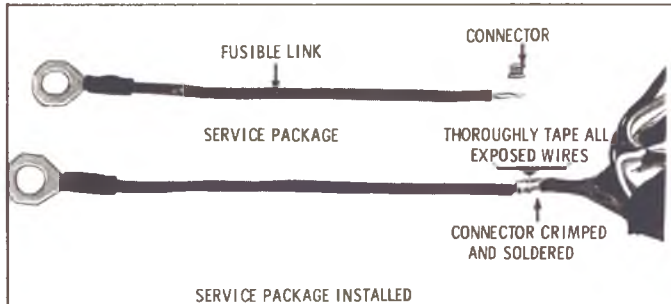

Fig. 54—Fusible Link Replacement

### Fusible Link Replacement (Fig. 54)

A new fusible link can be installed, after the short circuit is located and repaired, as follows:

1. Disconnect battery ground cable.
2. Disconnect fusible link from junction block or starter solenoid.
3. Cut harness directly behind connector to remove damaged fusible link (fig. 53).
4. Strip harness wire approximately 1/2".
5. Position clip around new fusible link and harness wire, crimp so that all wires are securely fastened.
6. Solder connection using rosin core solder. Use sufficient heat to obtain a good solder joint.
7. Tape all exposed wires with plastic electrical tape to prevent corrosion and shorting.
8. Connect fusible link to junction block or starter solenoid.
9. Connect battery ground cable.

### DIAGNOSIS

Failures in a circuit are usually caused by short or open circuits. Open circuits are usually caused by breaks in the wiring, faulty connections or mechanical failure in a component such as a switch or circuit breaker. Short circuits are usually caused by wires from different components of the circuit contacting one another or by a wire or component grounding to the metal of the body due to a screw driven through the wires, insulation cut through by a sharp metal edge, etc.

The following information may aid in locating and correcting a failure in the body wiring electrical system.

1. If a major portion of the electrical circuit becomes inoperative simultaneously, the failure may be due to improper connections between the front and rear harness, or between the front harness and the chassis wiring connector on top of fuse block.
2. If only one of the circuits is inoperative, the failure is due to an open circuit or short in the affected circuit. Short circuits usually result in blown fuses or in the case of power equipment circuits, in the circuit breaker opening the circuit. If the fuse is not blown and the circuit affected is a lamp circuit, check the bulb before proceeding with any checking procedures.
3. The dome lamp and courtesy lamp circuits are designed so that the switches are in the "ground" side of the circuit. If a condition is encountered where the lamps remain "on" even though the jamb or courtesy lamp switches are not actuated, the failure is probably due to defective switches, or to the wire leading to the switches being grounded to the metal body.

## DIAGNOSIS

### INDEX

Headlamp .....	12-45
Side Marker Lamp .....	12-46
Tail, Park, and License Lamp .....	12-47
Turn Signal and Hazard Warning .....	12-48
Back-up Lamp .....	12-49
Stop Lights .....	12-50
Oil Pressure Indicator .....	12-51
Coolant Temperature Indicator .....	12-51
Charging System Indicator .....	12-52
Horns .....	12-53
Speedometer .....	12-53
Fuel Gauge .....	12-54

# DIAGNOSIS

## HEADLAMP DIAGNOSIS

Condition	Possible Cause	Correction
One headlamp inoperative or intermittent	<ol style="list-style-type: none"><li>1. Loose connection</li><li>2. Defective Sealed Beam</li></ol>	<ol style="list-style-type: none"><li>1. Secure connections to sealed beam including ground. (Black Wire)</li><li>2. Replace sealed beam</li></ol>
One or more headlights are dim.	<ol style="list-style-type: none"><li>1. Open ground connection at headlight</li><li>2. Black ground wire mislocated in headlight connector (type 2 sealed beam)</li></ol>	<ol style="list-style-type: none"><li>1. Repair black wire connection between sealed beam and body ground.</li><li>2. Relocate black wire in connector</li></ol>
One or more headlights short life	<ol style="list-style-type: none"><li>1. Voltage regulator misadjusted</li></ol>	<ol style="list-style-type: none"><li>1. Readjust regulator to specifications.</li></ol>
All headlights inoperative or intermittent	<ol style="list-style-type: none"><li>1. Loose connection</li><li>2. Defective dimmer switch</li><li>3. Open wiring - light switch to dimmer switch</li><li>4. Open wiring - light switch to battery</li><li>5. Shorted ground circuit</li><li>6. Defective light switch</li></ol>	<ol style="list-style-type: none"><li>1. Check and secure connections at dimmer switch and light switch.</li><li>2. Check voltage at dimmer switch with test lamp. If test lamp bulb lights only at light blue wire terminal, replace dimmer switch.</li><li>3. Check light blue wire with test lamp. If bulb lights at light switch light blue wire terminal but not at dimmer switch, repair open wire.</li><li>4. Check red wire terminal at light switch with test lamp. If lamp does not light, repair open red wire circuit to battery. (possible open fusible link)</li><li>5. If, after a few minutes operation, headlights flicker "ON" and "OFF" and or a thumping noise can be heard from the light switch (circuit breaker opening and closing), repair short to ground in circuit between light switch and headlights. After repairing short, check for headlight flickering after one minute operation. If flickering occurs, the circuit breaker has been damaged and light switch must be replaced.</li><li>6. Check red and white wire terminals at light switch with test lamp. If bulb lights at red wire terminal but not at light blue terminal, replace light switch.</li></ol>



Upper or lower beam will not light or intermittent	1. Open connection or defective dimmer switch	1. Check dimmer switch terminals with test lamp. If bulb lights at light blue or tan wire terminals, repair open wiring between dimmer switch and headlights. If bulb will not light at one of these terminals, replace dimmer switch.
	2. Short circuit to ground	2. Follow diagnosis above (All headlights inoperative or intermittent)

**SIDE MARKER LAMP DIAGNOSIS**

Condition	Possible Cause	Correction
One lamp inoperative	1. Turn signal bulb burnt out (Front lamp)	1. Switch turn signals on. If signal bulb does not light, replace bulb. (Bulb filament provides ground path for marker lamp bulb through the light blue or dark blue/white strip wires).
	2. Side marker bulb burnt out	2. Replace bulb.
	3. Loose connection or open in wiring	3. Using test lamp, check brown wire terminal at bulb socket. If test lamp lights, repair open ground circuit. If lamp does not light, repair open brown wire circuit.
Front or rear lamps inoperative	1. Loose connection or open ground connection	1. If associated tail or park lamps do not operate, secure all connectors in brown wire circuit. If park and turn lamps operate, repair open ground connections.
	2. Multiple bulbs burnt out	2. Replace burnt out bulbs.
All lamps inoperative	1. Blown fuse	1. If park and tail lamps do not operate, replace blown fuse. If new fuse blows, check for short to ground between fuse panel and lamps.
	2. Loose connection	2. Secure connector to light switch.
	3. Open in wiring	3. Check tail light fuse with test lamp. If test lamp lights, repair open wiring between fuse and light switch. If not, repair open wiring between fuse and battery. (Possible open fusible link).

4. Defective light switch

4. Check light switch with test lamp. If test lamp lights at terminal No. 5 but not at terminal No. 4, replace light switch.

**TAIL, PARK AND LICENSE LAMP DIAGNOSIS**

<b>Condition</b>	<b>Possible Cause</b>	<b>Correction</b>
One side inoperative	1. Bulb burnt out	1. Replace bulb
	2. Open ground connection at bulb socket or ground wire terminal	2. Jumper bulb base socket connection to ground. If lamp lights, repair open ground circuit.
Both sides inoperative	1. Tail lamp fuse blown	1. Replace fuse. If new fuse blows, repair short to ground in brown wire circuit between fuse panel through light switch to lamps.
	2. Loose connection	2. Secure connector at light switch.
	3. Open wiring	3. Using test light, check circuit on both sides of fuse. If lamp does not light on either side, repair open circuit between fuse panel and battery. (possible open fusible link). If test lamp lights at light switch brown wire terminal, repair open wiring between light switch and lamps.
	4. Multiple bulb burnout	4. If test lamp lights at lamp socket brown wire terminal, replace bulbs.
	5. Defective light switch	5. If test lamp lights at light switch terminal No. 4 (Brown/white wire) but not at terminal No. 5 (Brown wire), replace defective light switch.

## TURN SIGNAL AND HAZARD WARNING LAMP

Condition	Possible Cause	Correction
Turn signals inoperative one side	1. Bulb(s) burnt out (Flasher cannot be heard)	1. Turn hazard warning system on. If one or more bulbs are inoperative replace necessary bulbs.
	2. Open wiring or ground connection	2. Turn Hazard warning system on. If one or more bulbs are inoperative, use test lamp and check circuit at lamp socket. If test lamp lights, repair open ground connection. If not, repair open wiring between bulb socket and turn signal switch.
	3. Improper bulb or defective turn signal switch.	3. Turn hazard warning system on. If all front and rear lamps operate, check for improper bulb (1034 instead of 1157). If bulbs are OK, replace defective turn signal switch.
	4. Short to ground. (Flasher can be heard, no bulbs operate)	4. Locate and repair short to ground by disconnecting front and rear circuits separately.
Turn signals inoperative	1. Blown turn signal fuse	1. Turn hazard warning system on. If all lamps operate, replace blown fuse. If new fuse blows, repair short to ground between fuse and lamps.
	2. Defective flasher (Located behind instrument panel near steering column)	2. If turn signal fuse is OK and hazard warning system will operate lamps, replace defective turn signal flasher.
	3. Loose connection	3. Secure steering column connector.  If necessary, check purple wire terminals in connector with test lamp. If test lamp lights only on one side of connector, clean or tighten connector contacts.

Hazard warning lamps inoperative	<ol style="list-style-type: none"> <li>1. Blown stop-hazard fuse</li> <li>2. Defective hazard warning flasher. (Located on fuse panel).</li> <li>3. Open in wiring or defective turn signal switch.</li> </ol>	<ol style="list-style-type: none"> <li>1. Switch turn signals on. If lamps operate, replace stop-hazard fuse if blown. If new fuse blows, repair short to ground. (Could be in stop light circuit).</li> <li>2. If stop-hazard fuse is OK, switch turn signals on. If lamps operate, replace defective hazard flasher.</li> <li>3. Using test lamp, check brown wire in turn signal steering column connector. If lamp does not light on either side of connector, repair open circuit between flasher and connector. If lamp lights only on feed side of connector, clean connector contacts. If lamp lights on both sides of connector, replace defective turn signal switch assembly.</li> </ol>
----------------------------------	--	---

**BACK-UP LAMP**

Condition	Possible Cause	Correction
One lamp inoperative or intermittent	<ol style="list-style-type: none"> <li>1. Loose or burnt out bulb</li> <li>2. Loose connection</li> <li>3. Open ground connections</li> </ol>	<ol style="list-style-type: none"> <li>1. Secure or replace bulb.</li> <li>2. Tighten connectors.</li> <li>3. Repair bulb ground circuit.</li> </ol>
Both lamps inoperative or intermittent.	<ol style="list-style-type: none"> <li>1. Neutral start switch misadjusted (Open when shift lever is in reverse position)</li> <li>2. Loose connection or open circuit</li> <li>3. Blown fuse</li> <li>4. Defective neutral start switch</li> <li>5. Defective ignition switch</li> </ol>	<ol style="list-style-type: none"> <li>1. Readjust neutral start switch.</li> <li>2. Secure all connectors. If OK, check continuity of circuit from fuse to lamps with test lamp. If lamp does not light on either side of fuse, correct open circuit from battery to fuse.</li> <li>3. Replace fuse. If new fuse blows, repair short to ground in circuit from fuse through neutral start switch to back-up lamps.</li> <li>4. With ignition on, check switch terminals in back-up position with test lamp. If lamp lights at pink wire terminal but not at light green wire terminal, replace neutral start switch.</li> <li>5. If test lamp lights at ignition switch battery terminal but not at output terminal, replace ignition switch.</li> </ol>

Lamp will not turn off	1. Neutral start switch misadjusted (closed when shift lever is not in reverse position)	1. Readjust neutral start switch
------------------------	--	----------------------------------

**STOP LIGHTS**

Condition	Possible Cause	Correction
One bulb inoperative	1. Bulb burnt out.	1. Replace bulb.
One side inoperative	1. Loose connection, open wiring or defective bulbs	1. Turn on directional signal. If lamp does not operate, check bulbs. If bulbs are OK, secure all connections. If lamp still does not operate, use test lamp and check for open wiring.
	2. Defective directional signal switch or cancelling cam	2. If lamp will operate by turning directional signal on, the switch is not centering properly during cancelling operation. Replace defective cancelling cam or directional signal switch.
All inoperative	1. Stop-hazard fuse blown	1. Replace fuse. If new fuse blows, repair short to ground in circuit between fuse and lamps.
	2. Stop-switch misadjusted or defective	2. With brake pedal depressed, check white wire terminal in steering column connector with test lamp. If lamp does not light, check stop switch for proper adjustment. If adjustment is OK, replace stop switch.
Will not turn off	1. Stop switch misadjusted or defective.	1. Readjust switch. If switch still malfunctions, replace.

**OIL PRESSURE INDICATOR**

<b>Condition</b>	<b>Possible Cause</b>	<b>Correction</b>
Light not lit, ignition on and engine not running.	1. Bulb burned out.	1. Replace bulb.
	2. Open in light circuit.	2. Locate and correct open.
	3. Defective oil pressure switch.	3. Replace oil pressure switch.
Light on, engine running above idle speed.	1. Grounded wiring between light and switch.	1. Locate and repair ground.
	2. Defective oil pressure switch.	2. Replace oil pressure switch.
	3. Low oil pressure.	3. Locate cause of low oil pressure and correct.

**COOLANT TEMPERATURE INDICATOR**

<b>Condition</b>	<b>Possible Cause</b>	<b>Correction</b>
"HOT" indicator; light not lit when cranking engine.	1. Bulb burned out.	1. Replace bulb.
	2. Open in light circuit.	2. Locate and correct open.
	3. Defective ignition switch.	3. Replace ignition switch.
Light on, engine running.	1. Wiring grounded between light and switch.	1. Locate and correct grounded wiring.
	2. Defective temperature switch.	2. Replace temperature switch.
	3. Defective ignition switch.	3. Replace ignition switch.
	4. Coolant temperature above 258 degrees F.	4. Locate and correct cause of high coolant temperature.

## CHARGING SYSTEM INDICATOR

Condition	Possible Cause	Correction
Light on, ignition off.	1. Shorted positive diode.	1. Locate and replace shorted diode.
Light not on, ignition on and engine not running.	1. Bulb burned out.	1. Replace bulb.
	2. Open in light circuit.	2. Locate and correct open.
	3. Open in field.	3. Replace rotor.
Light on, engine running above idle speed.	1. No generator output.	1. Check and correct cause of no output.
	2. Shorted negative diode.	2. Locate and replace shorted diode.
	3. Loose or broken generator belt.	3. Tighten or replace and tighten generator belt.

**HORNS WILL NOT OPERATE**

Cause	Correction
Loose connections in circuit.	Check and tighten connections. Be sure to check ground straps.
Defective horn switch.	Replace defective parts.
Defective horn relay.	Replace relay.
Defects within horn.	Replace horn.

**HORNS HAVE POOR TONE**

Cause	Correction
Low available voltage at horn.	Check battery and charging circuit.
Defects within horn.	Although horn should blow at any voltage above 7.0 volts, a weak or poor tone may occur at operating voltages below 11.0 volts. If horn has weak or poor tone at operating voltage of 11.0 volts or higher, remove horn and replace.

**HORNS OPERATE INTERMITTENTLY**

Cause	Correction
Loose or intermittent connections in horn relay or horn circuit.	Check and tighten connections.
Defective horn switch.	Replace switch.
Defective relay.	Replace relay.
Defects within horn.	Replace horn.

**HORNS BLOW CONSTANTLY**

Cause	Correction
Sticking horn relay.	Replace relay.
Horn relay energized by grounded or shorted wiring.	Check and adjust wiring.
Horn button can be grounded by sticking closed.	Adjust or replace damaged parts.

**SPEEDOMETER**

Cause	Correction
Noisy speedometer cable.	1. Loosen over-tightened casing nuts and snap-on at speedometer head.
Pointer and odometer inoperative.	2. Replace housing and core.
Inaccurate reading.	Replace broken cable.
Kinked cable.	1. Check tire size.
Defective speedometer head.	2. Check for correct speedometer driven gear.
Casing connector loose on speedometer case.	Replace cable. Reroute casing so that bends have no less than 6" radius.
	Replace or have repaired at authorized service station.
	Tighten connector.



DASH UNIT NEVER READS EMPTY  
OR  
DASH UNIT READS FULL AT ALL  
TIMES WITH IGNITION ON

1. Check for disconnected or loose tank unit feed wire at tank unit.
2. Connect Gas Gauge Tester J-22344 to tank unit feed wire and observe dash unit.

**No Improvement**

1. Check cluster fuse.
2. Check for proper connections at: Dash unit to printed circuit, I.P. harness to printed circuit, Flat wire to I.P. harness, Trunk harness to flat wire.
3. Remove dash unit and check.

**Dash Unit Reads Okay**

1. Check ground wire from tank unit to trunk floor pan for continuity.

**ERRATIC FUEL GAUGE READINGS  
AND OFF CALIBRATION COMPLAINTS**  
(Gauge fluctuation during acceleration and deceleration is normal.)

- Check the following for loose connection:
1. Dash unit mounting screws.
  2. I.P. harness to printed circuit.
  3. I.P. harness to flat wire.
  4. Flat wire to trunk harness.
  5. Feed wire to tank unit.
  6. Tank unit ground to body.

DASH UNIT READS EMPTY AT  
ALL TIMES WITH IGNITION ON

1. Disconnect tank unit feed wire. Dash unit should now read full.

**Gauge Reads Full**

1. Check for grounded tank unit lead.
2. Remove tank unit and check.

**Gauge Does Not Read Full**

1. Check cluster fuse.
2. Check for proper connections at: Dash unit to printed circuit, I.P. harness to printed circuit.
3. If dash unit is okay, check for opens in printed circuit or shorts due to pinched wires in the body harness.
4. Remove dash unit and check.

**NOTE:** Many fuel gauge tank units and dash units are replaced because of poor diagnosis or lack of knowledge of the variables in the system. For example, some owners complain that when their gauge reads empty the tank cannot be filled to the capacity stated in the owner's manual.

Possible reasons:

1. Empty fuel reserve of 1 to 3 gallons.
2. Gas station attendant did not take time to completely fill the tank.
3. Car was filled on a hill or with a heavy trunk load causing the tank vent pipe to be blocked and therefore preventing the tank from being completely filled.

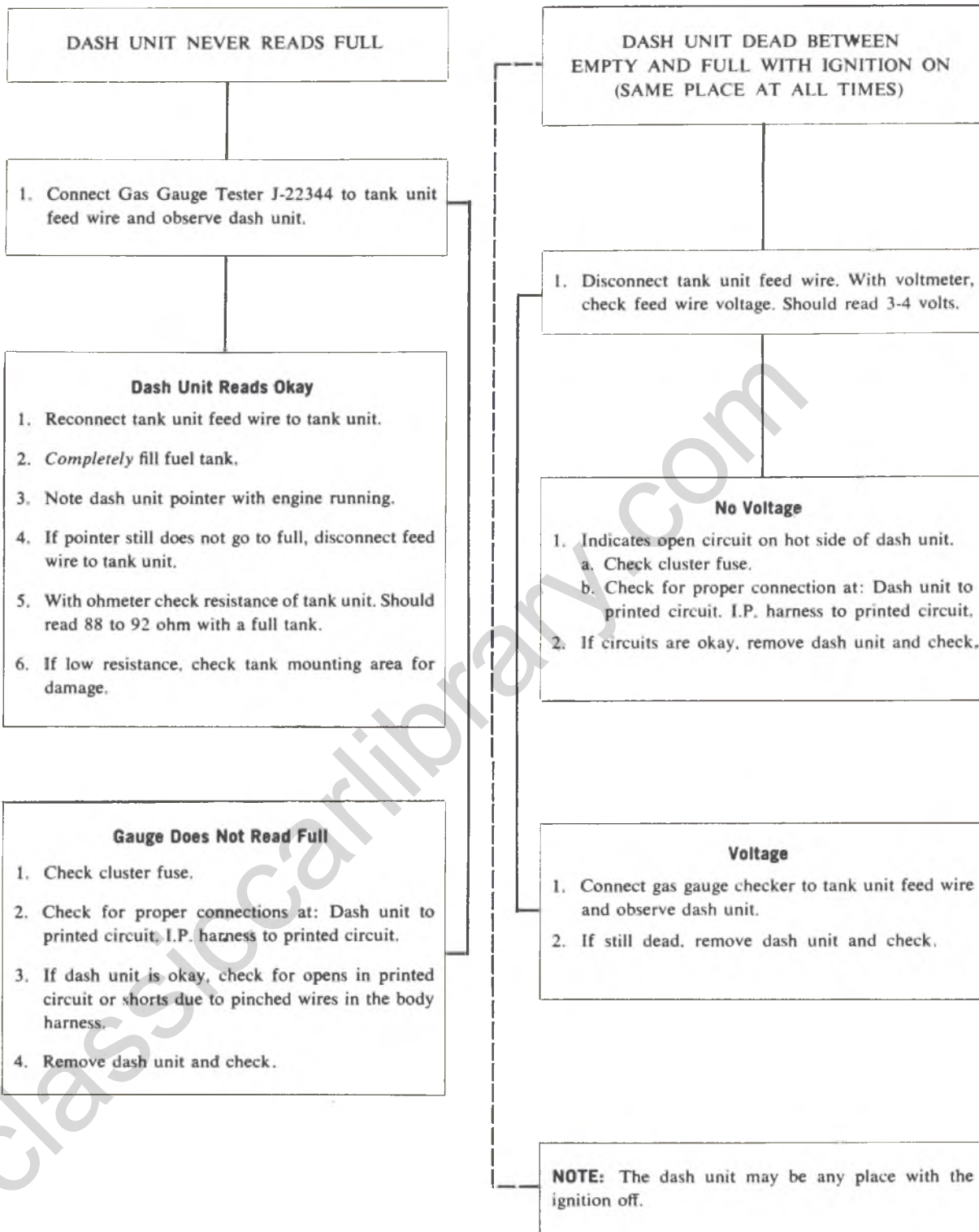

classiccarylbrary.com

**SECTION 13**  
**RADIATOR AND GRILLE**  
**CONTENTS OF THIS SECTION**

Radiator.....	13-1	Grille .....	13-1
---------------	------	--------------	------

**RADIATOR**

**INDEX**

General Description .....	13-1	Radiator Replacement (except P30(32)Chassis) ....	13-1
Service Procedure.....	13-1	Radiator Replacement (P30(32) Chassis).....	13-2
Maintenance .....	13-1	Coolant Recovery System .....	13-5

**GENERAL DESCRIPTION**

P30 (32) Chassis is equipped with down-flow radiator.

All other models are equipped with cross-flow radiators. The cross-flow radiator is similar to the down-flow radiator except it is mounted sideways in the vehicle and attached in the conventional manner.

All models are equipped with a recovery type cooling system which is designed to maintain the engine at proper operating temperature. The coolant recovery tank

collects coolant that expands with rising temperature that would otherwise overflow from system. When system temperature drops, coolant is drawn from recovery tank back into radiator by the suction created by coolant contraction.

Coolant recovery tank level should be at "Full-Cold" line when cold. At normal operating temperatures, tank level will reach "Full-Hot" line.

**SERVICE PROCEDURES**

**MAINTENANCE**

For maintenance and checking cooling system, refer to Section 6K, Engine Cooling System.

For cooling system capacities, refer to Section 0, General Information and Periodic Maintenance.

If a fan blade is bent or damaged in any way, no attempt should be made to repair and reuse the damaged part. A bent or damaged fan assembly should always be replaced with a new fan assembly.

It is essential that fan assemblies remain in proper balance and proper balance cannot be assured once a fan assembly has been bent or damaged.

**RADIATOR REPLACEMENT**

**(All Except P30 (32) Chassis)**

Refer to Figures 1, 3 and 4 for radiator assembled positions for each vehicle.

**Removal**

1. Remove radiator cap when engine is cool by:
  - Slowly rotating cap counter clockwise to detent (do not press down while rotating).
  - Wait until any residual pressure (indicated by a hissing sound) is relieved.
  - After all hissing ceases, press down on cap while continuing to rotate counterclockwise.

**CAUTION:** *To avoid the danger of being burned, do not remove radiator cap while engine and radiator are still hot because scalding fluid and steam will be blown out under pressure.*

2. Open drain cock and drain radiator.
3. Disconnect upper and lower radiator hoses and transmission oil cooler lines or heater hose, if equipped.

## 13-2 RADIATOR AND GRILLE

4. Disconnect coolant recovery system hose (figs. 5 through 7).
5. If shroud installed, remove shroud to radiator screws and lift shroud out of lower clips and carefully hang shroud over engine fan assembly to provide clearance for radiator removal.
6. Remove finger guard (G Series, L6 engine only).
7. Remove radiator upper mounting panel (retainers on G Series) from radiator support. Remove upper mounting pads.
8. Lift radiator out of the lower mountings and remove from vehicle. Lift shroud out of vehicle if applicable.

### Installation

1. Inspect mounting pads and mounting panel or retainers and replace as required.
2. With fan shroud positioned over fan, lower radiator into lower mountings and install radiator upper mounting panel.
3. Install fan shroud if so equipped.
4. Connect upper and lower radiator hoses and coolant recovery system hose. Inspect hose clamps and all hoses. Replace hoses whenever swollen, checked or otherwise deteriorated.
5. Connect transmission oil cooler lines or heater hose, if equipped.
6. Remove coolant recovery tank and empty of fluid. Flush tank with clean water, drain and reinstall.
7. Add sufficient ethylene glycol coolant, meeting GM Specification 1899-M, to provide the required freezing and corrosion protection - at least a 44 percent solution (20° F). Fill radiator to the base of radiator filler neck and add sufficient coolant to

recovery tank to raise level to the "FULL-HOT" mark. Reinstall recovery tank cap.

10. Pressure test system and radiator cap for proper pressure holding capacity (15 psi). If replacement of cap is required, use the proper cap specified for your vehicle.

## RADIATOR REPLACEMENT

### (P30 (32) Chassis) (Fig. 2)

#### Removal

1. Remove radiator cap when engine is cool by:
  - Slowly rotating cap counter clockwise to detent (do not press down while rotating).
  - Wait until any residual pressure (indicated by a hissing sound) is relieved.
  - After all hissing ceases, press down on cap while continuing to rotate counterclockwise.

**CAUTION:** To avoid the danger of being burned, do not remove radiator cap while engine and radiator are still hot because scalding fluid and steam will be blown out under pressure.

2. Open drain cock and drain radiator.
3. Disconnect upper and lower radiator hoses, coolant recovery hose and transmission oil cooler lines.
4. Place vehicle on hoist or raise front end.
5. Remove four (4) screws from lower support and remove support.
6. Lower radiator from vehicle.

#### Installation

1. Inspect mounting pads in upper and lower support retainers and replace as required.

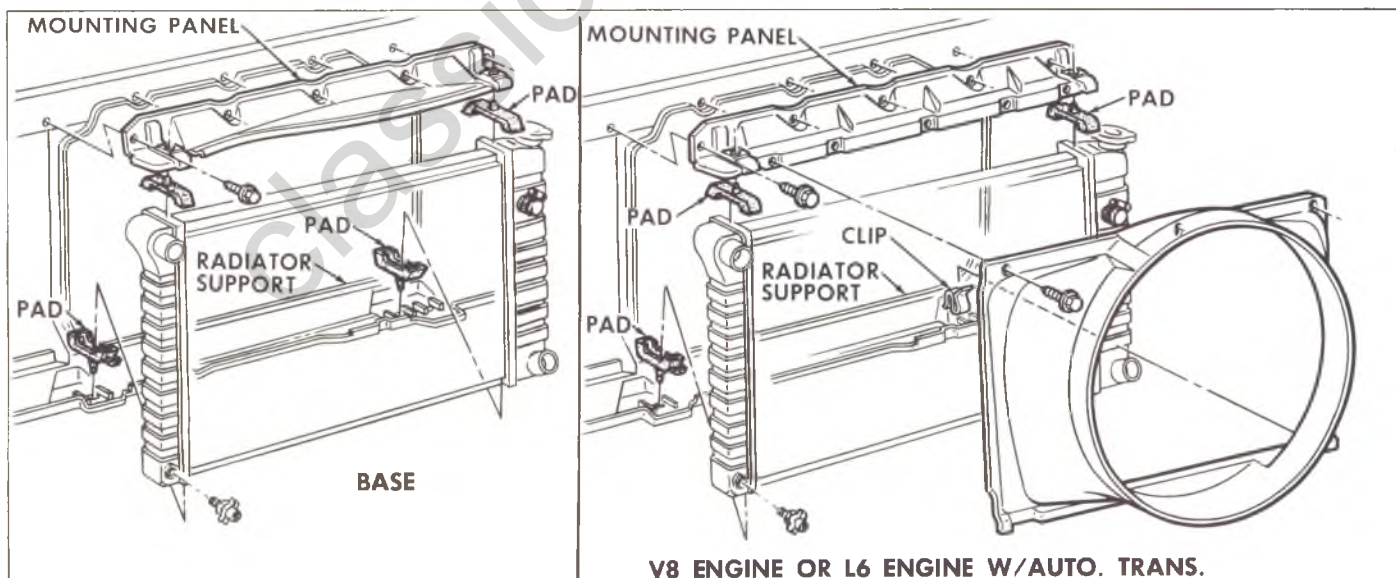

Fig. 1—Radiator and Fan Shroud—CK/P Series

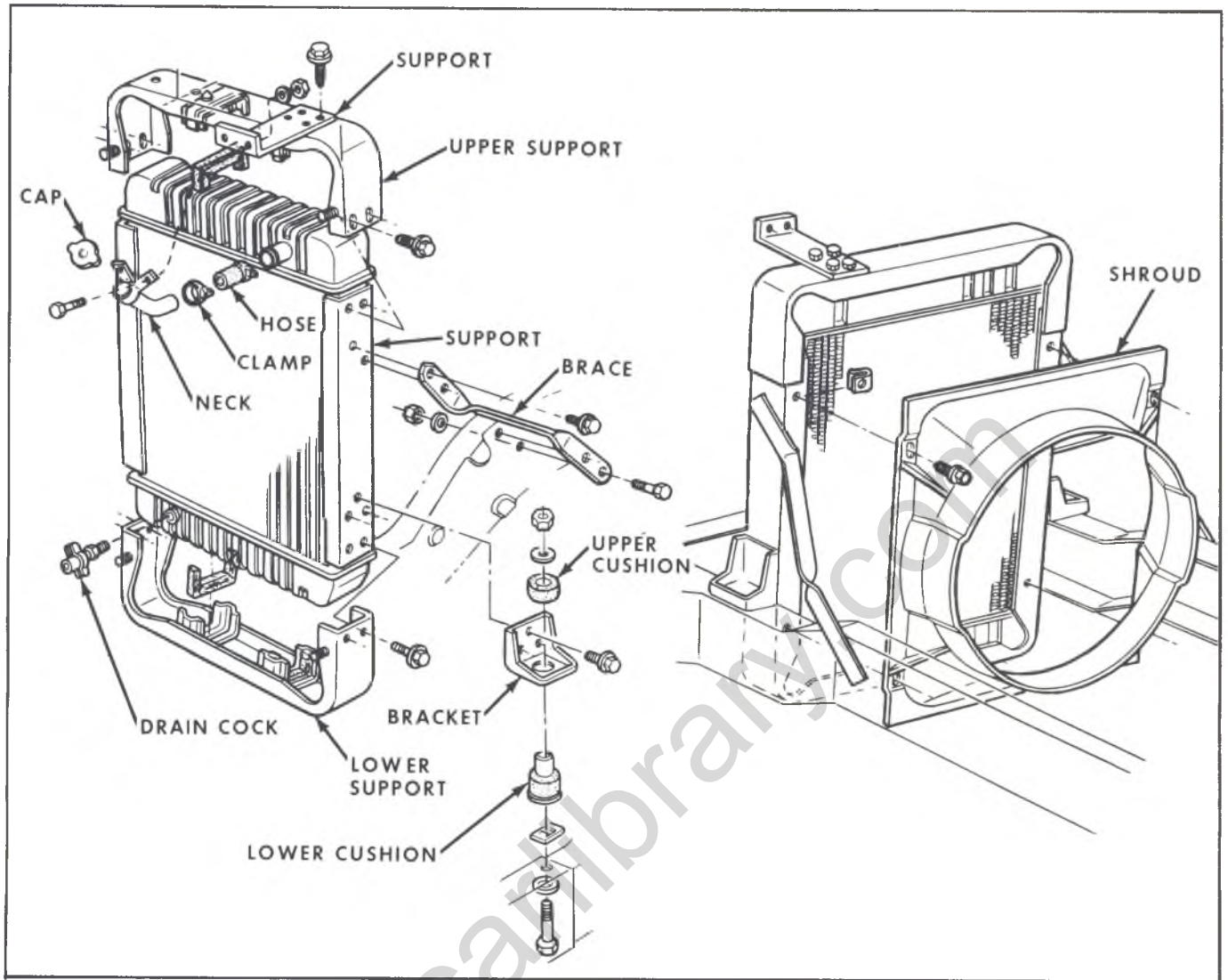

Fig. 2—Radiator and Fan Shroud—P30 (32)

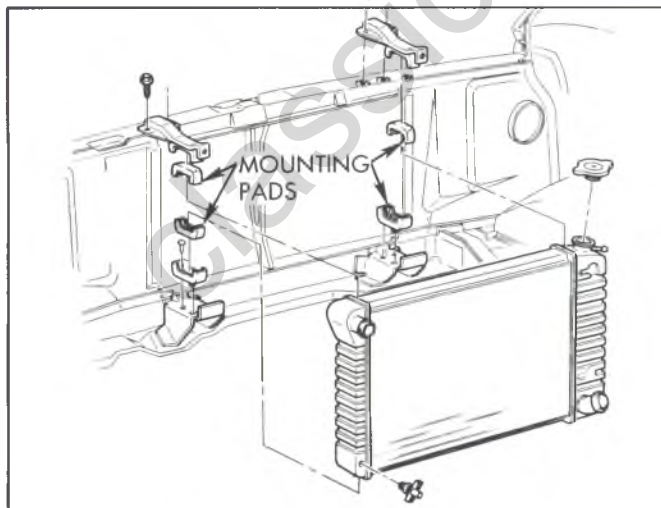

Fig. 3—Radiator Mounting—G Series

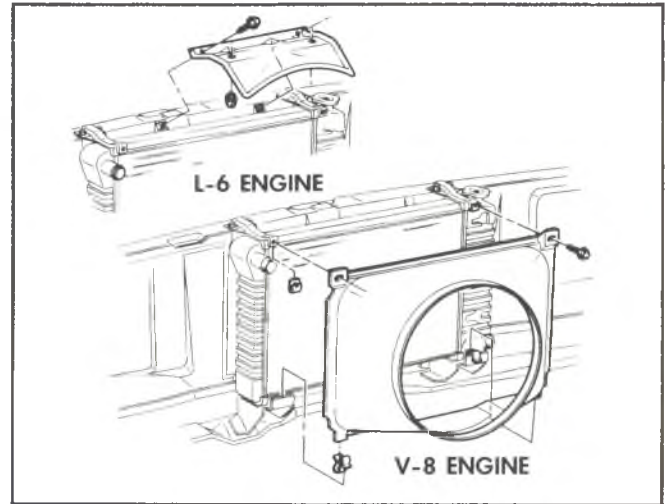

Fig. 4—Radiator Shrouds—G Series

## 13-4 RADIATOR AND GRILLE

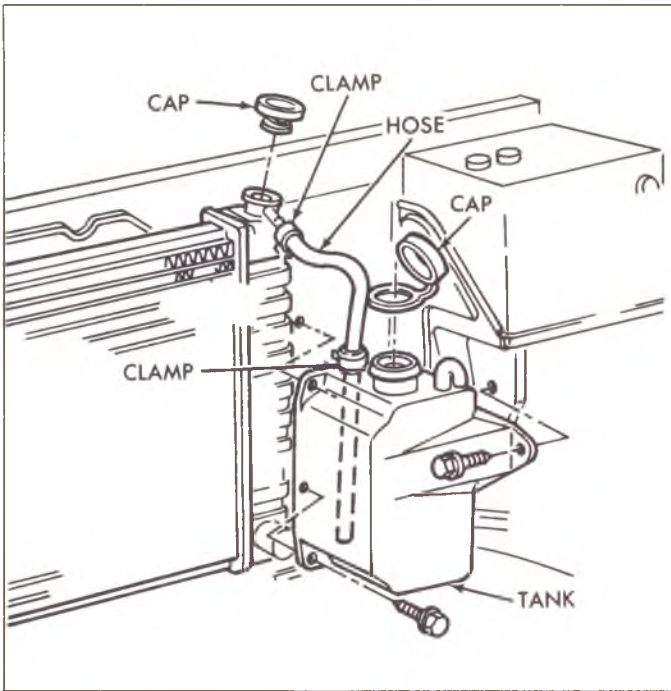

Fig. 5—Coolant Recovery Tank—CK Series

2. Before installing radiator, coat rubber radiator retaining pads with a rubber lubricant.
3. Install radiator being sure that radiator tank ribs align with mounting pads in upper and lower support retainers. Radiator tanks must be fully

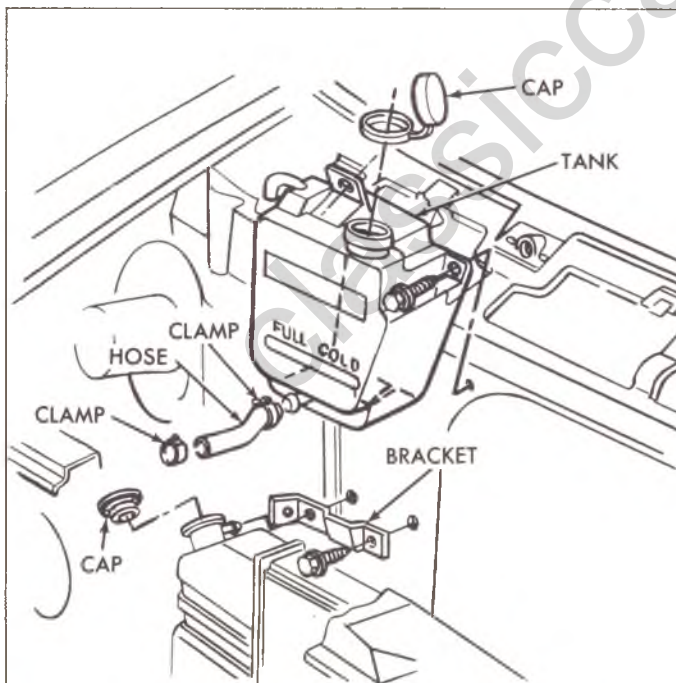

Fig. 6—Coolant Recovery Tank—G Series

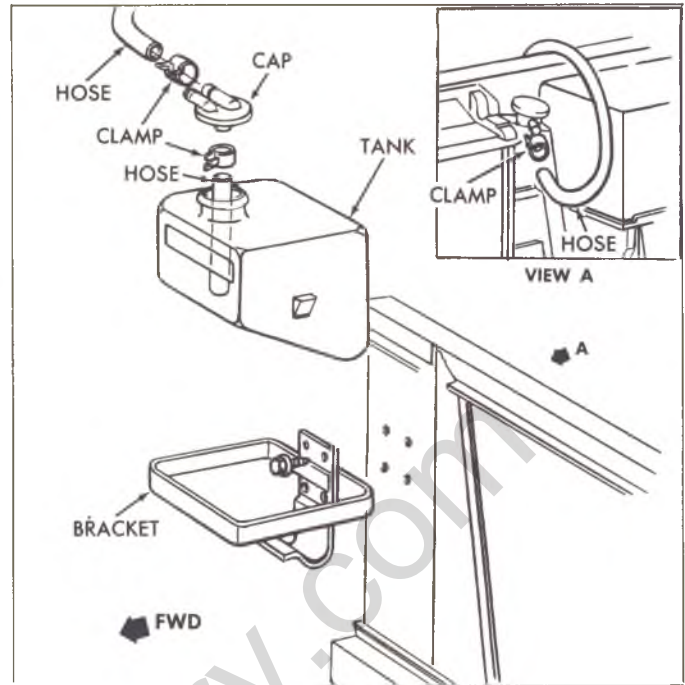

Fig. 7—Coolant Recovery Tank—P(42) Series

seated around radiator support retainers. Do not crush radiator tanks.

4. Connect upper and lower radiator hoses and coolant recovery system hose. Inspect hose clamps and all hoses. Replace hoses whenever swollen, checked or otherwise deteriorated.
5. Connect transmission oil cooler lines.
6. Tighten screws to proper torque valve.

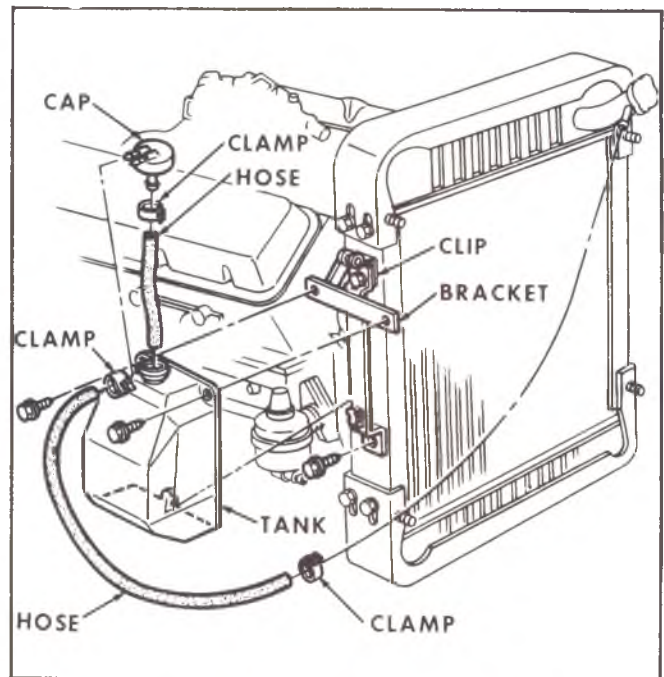

Fig. 8—Coolant Recovery System—P30 (32)

7. Remove coolant recovery tank and empty of fluid. Flush tank with clean water, drain and reinstall.
8. Add sufficient ethylene glycol coolant, meeting GM Specification 1899-M, to provide the required freezing and corrosion protection - at least a 44 percent solution (20° F). Fill radiator to the base of radiator filler neck and add sufficient coolant to recovery tank to raise level to the "FULL-HOT" mark. Reinstall recovery tank cap.
9. Run engine, with radiator cap removed, until normal operating temperature is reached. (Radiator upper hose becomes hot).
10. With engine idling, add coolant until level reaches bottom of filler neck and install radiator cap making arrows on cap line up with overflow tube.
11. Pressure test system and radiator cap for proper pressure holding capacity (15 psi). If replacement of

cap is required, use the proper cap specified for your vehicle.

**CAUTION:** Radiator support is not a structural member. No body mounting supports or other attachments used for structural purposes are to be fastened to radiator support.

### COOLANT RECOVERY SYSTEM

Refer to Figure 5 for removal and installation of coolant recovery system on CK Series.

Refer to Figure 6 for removal and installation of coolant recovery system on G Series.

Refer to Figure 7 for removal and installation of coolant recovery system on P(42) Series.

Refer to Figure 8 for coolant recovery system on P30 (32) chassis.

## GRILLE SERVICE PROCEDURES

### GRILLE - CK SERIES (Fig. 9)

#### Removal

1. Remove the eight (8) screws retaining grille to brackets and support assembly.
2. Remove bezels as required.

#### Installation

Reverse removal procedure.

**CAUTION:** Grille is made of plastic. Do not use excessive heat or harsh chemicals to clean in this area to prevent distortion and/or paint peeling.

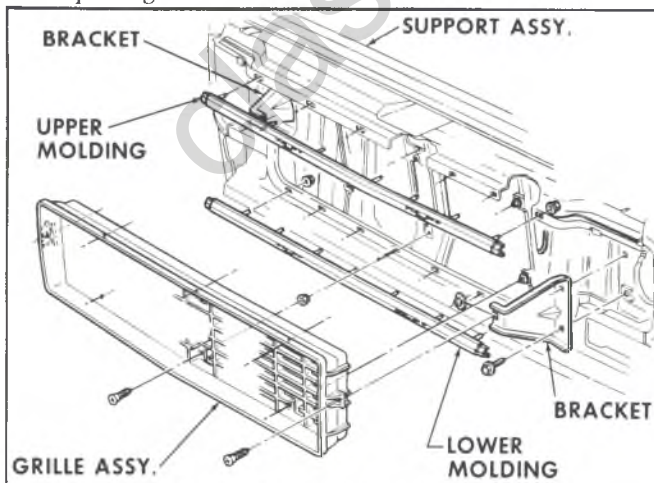

Fig. 9—Radiator Grille—CK Series

### GRILLE - G SERIES (Fig. 10)

#### Removal

1. Remove left and right headlamp bezels.
2. Remove attaching screws. Grille to cross sill, body and radiator support and remove the grille.

#### Installation

Install the grille in reverse order of removal.

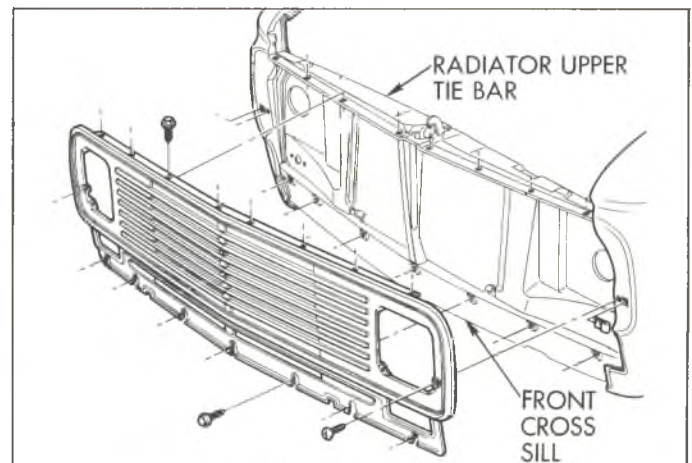

Fig. 10—Radiator Grille—G Series



classiccarylbrary.com

## SECTION 14 BUMPERS

### INDEX

General Description .....	14-1	Rear Bumper - C and K Models .....	14-1
Service Procedures - 10 thru 30 Series .....	14-1	Rear Step Bumper - C and K Models .....	14-2
Front Bumper - C, K and P Models .....	14-1	Front Bumper G Series .....	14-2
		Rear Bumper G Series .....	14-2

## GENERAL DESCRIPTION

All 1974 truck front and rear bumpers are of a single piece design. Bumper attachments are the standard bracket and brace to frame mountings. This section

contains procedures for the removal and installation of face bars, brackets, braces and license plate brackets.

## SERVICE PROCEDURES—10 THRU 30 SERIES

### FRONT BUMPER—C, K AND P MODELS (Fig. 1)

#### Removal

1. Remove bolts securing two bumper brackets to frame.
2. Remove bolts securing bumper face bar to frame, and left and right bumper braces and remove bumper from vehicle.
3. If necessary, disassemble bumper by removing bolts attaching brackets and braces to bumper face bar.

#### Installation

Assemble and install front bumper following the removal procedure in reverse order. Refer to torque specifications in rear of manual for correct torque values.

### REAR BUMPER—C AND K MODELS (Fig. 2)

#### Removal

1. Remove bolts attaching bumper to each bumper brace. Disconnect license lamp wiring on suburban and panels and pickup.
2. Remove bolts attaching bumper to frame.
3. Remove bumper from vehicle.
4. If necessary, replace body dirt seal.

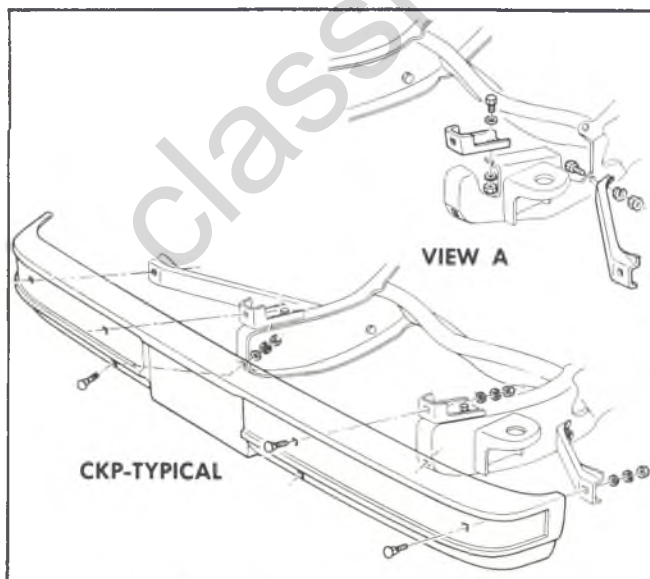

Fig. 1—Front Bumper—C, K and P Models

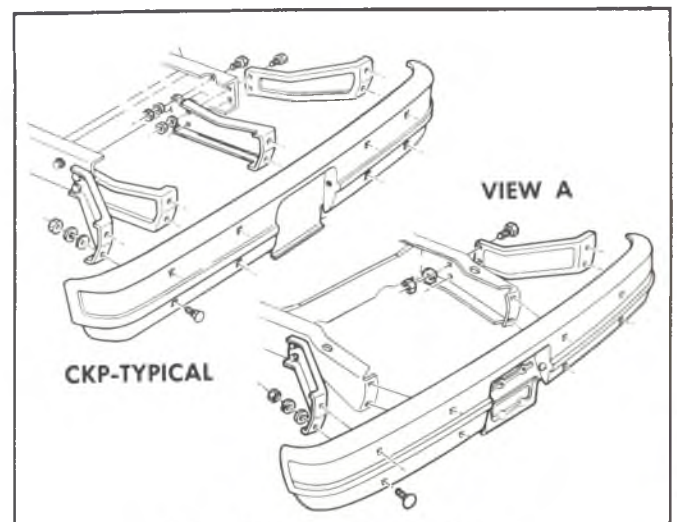

Fig. 2—Rear Bumper—C-K Models

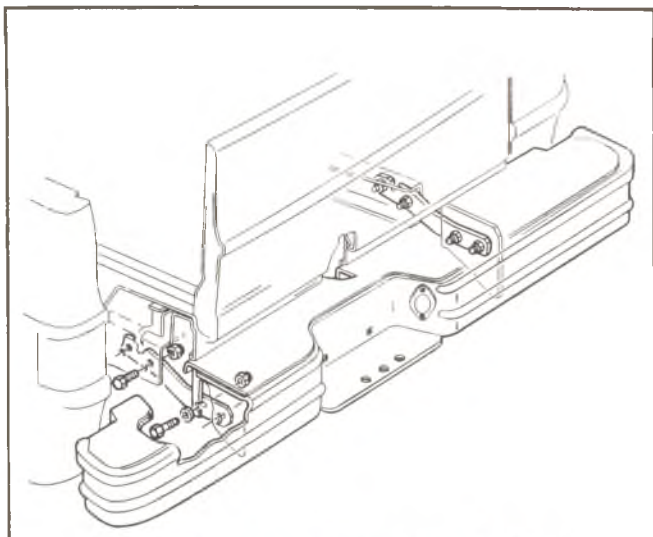

Fig. 3—Rear Step Bumper C and K Models

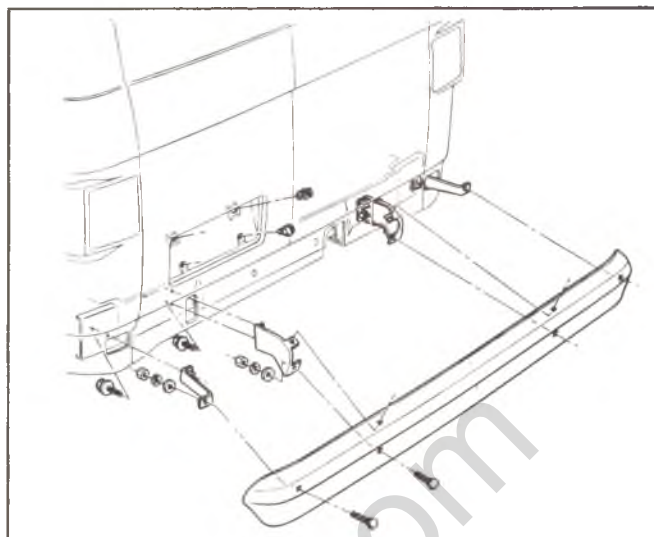

Fig. 5—Rear Bumper—G Models

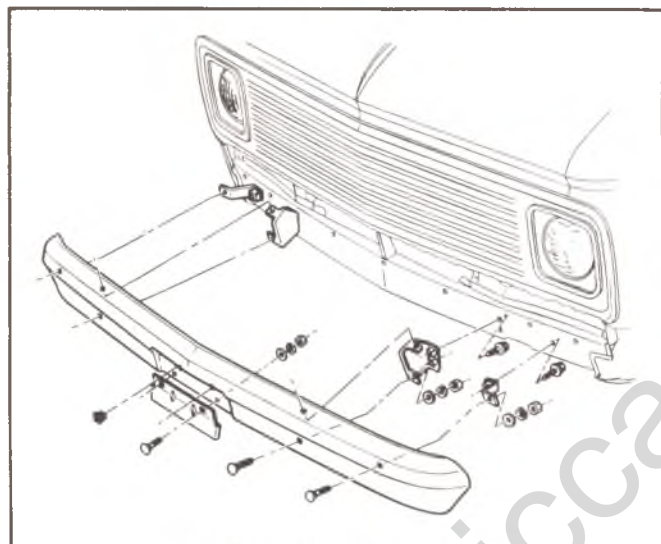

Fig. 4—Front Bumper—G Models

#### Installation

Install rear bumper following removal procedure in reverse order. Connect license lamp wiring on suburban, panel, and pickup models. Refer to torque specifications at the rear of this manual for correct torque values.

### REAR STEP BUMPER C AND K MODELS

#### Removal (Fig. 3)

1. Disconnect license lamp wiring.
2. Remove bolts connecting bumper to braces.
3. Remove bumper assembly.
4. Remove bolts securing bumper brace to frame and remove brace.

#### Installation

Install rear step bumper by reversing removal procedure. Connect license lamp wiring. Refer to torque specifications at the rear of this manual for correct torque values.

### FRONT BUMPER—G MODELS

#### Removal Fig. 4

1. Remove nuts securing bumper to brackets and braces from left and right side. Remove bumper.
2. Remove the license plate support nuts and bolts.
3. If necessary to remove the braces and brackets: remove screws securing brackets and braces to sheet metal.

NOTE: The bumper may be removed with brackets and braces attached.

#### Installation

Install in reverse order of removal. Refer to torque specifications at rear of this manual for correct torque values.

### REAR BUMPER—G MODELS

#### Removal Fig. 5

1. Remove nuts securing bumper to brackets and braces and remove the bumper.
2. Remove brackets and braces from vehicle.

NOTE: The bumper may be removed with brackets and braces attached if necessary.

#### Installation

Install in reverse order of removal. Refer to torque specifications at the rear of this manual for correct torque values.

# SECTION 15 ACCESSORIES

## INDEX

General Description .....	15-1
Maintenance and Adjustments .....	15-1
Component Part Replacement .....	15-2
Radio .....	15-2
Speaker .....	15-3
Antenna .....	15-4
Diagnosis .....	15-4

## GENERAL DESCRIPTION

AM and AM/FM radios are available on the C-K model trucks; AM only on G model trucks.

C-K model trucks incorporate a windshield antenna. The

antenna lead snaps onto the center of the windshield, inside the vehicle. G model antennas are mounted externally on the right front fender.

## MAINTENANCE AND ADJUSTMENTS

### RADIO INSTALLATION PRECAUTIONS

Listed below are common causes of inoperative radio receivers or poor reception on the AM scale upon reinstallation after repair.

- Radio speakers not connected--this could cause the output transistor to burn out in the receiver.
- Antenna lead not plugged into the receiver or windshield.
- Antenna trimmer not peaked.

### TRIMMING RADIO

If diagnosis indicates the radio receiver must be trimmed, perform the following procedure:

1. **G Models** Set antenna mast at maximum height.
2. Remove the tuner control knob and bezel (right hand knob).
3. Place the ignition key in the "ACC" position.
4. Turn the volume control to maximum volume.
5. Tune the radio to a weak station (near 1400 KC) on the AM scale.

6. Adjust the antenna trimmer screw ( $\pm 2^\circ$  screw rotation) until maximum volume is received (fig. 1).
7. Turn the radio volume off.
8. Replace the tuner control bezel and knob.
9. Turn the ignition to "lock".

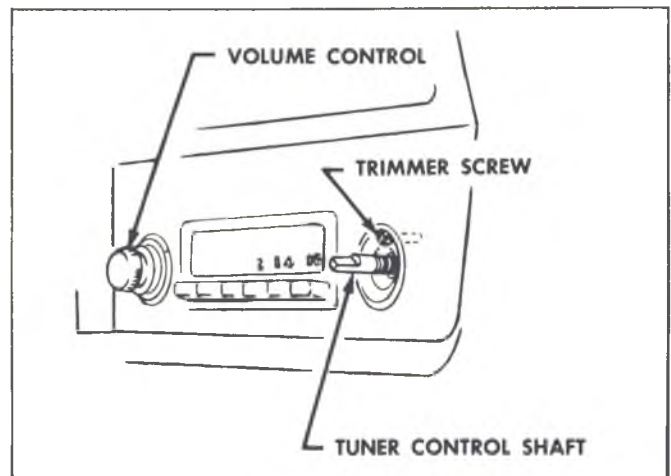

Fig. 1--Trimming Radio

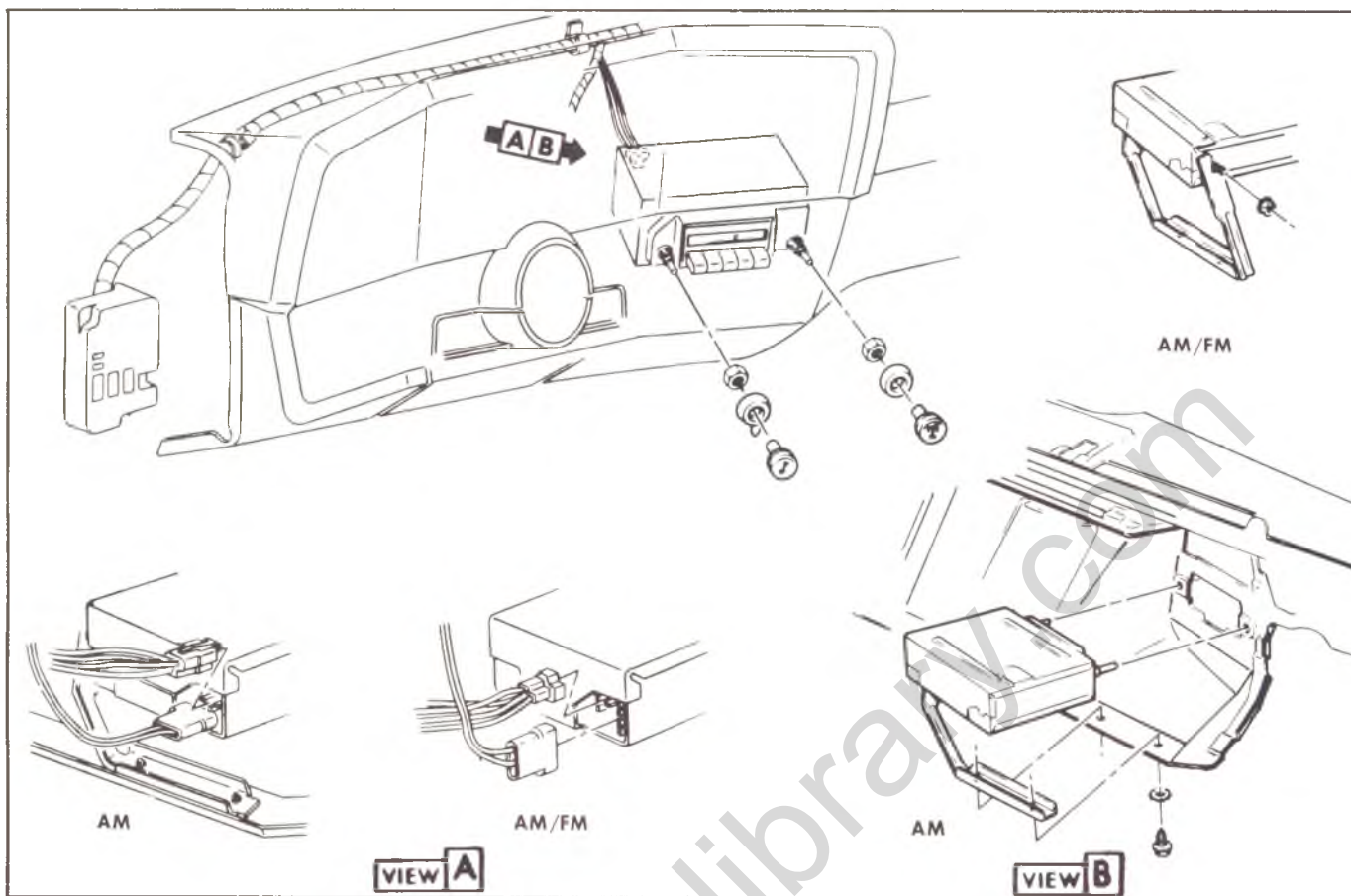

Fig. 2--Radio Installation (C-K Models)

## COMPONENT PART REPLACEMENT

### RADIO

#### C-K Models

##### Replacement (Fig. 2)

1. Disconnect the battery ground cable.
2. Pull off radio control knobs and remove knob bezels. Remove the nuts and washers from the control shafts using a deep well socket.
3. **AM Radio**—Remove the radio support bracket stud nut and lockwasher.  
**AM/FM Radio**—Remove the radio support bracket to instrument panel screws.
4. Lift up on the rear edge of the radio. Then push the radio forward until the control shafts clear the instrument panel. Lower the control far enough to disconnect the electrical harness.
5. Disconnect the power feed, speaker and antenna lead wires and remove the radio.
6. To install, reverse Steps 1-5 above.

#### G Models

##### Replacement (Fig. 3)

1. Disconnect ground cable from battery.
2. Remove engine cover.
3. Remove air cleaner on carburetor.
4. Remove stud in carburetor throat for mounting air cleaner.
5. Cover carburetor throat with clean plastic to prevent dirt or radio attachments from falling into carburetor.
6. Remove knobs, washers and nuts from control shafts on front of radio.
7. Remove bracket to radio receiver screw.
8. Now guide radio forward and then down through engine access area. Lower the radio far enough to disconnect electrical connectors and antenna lead. Remove radio.
9. Reverse Steps 1-8 for installation of radio.

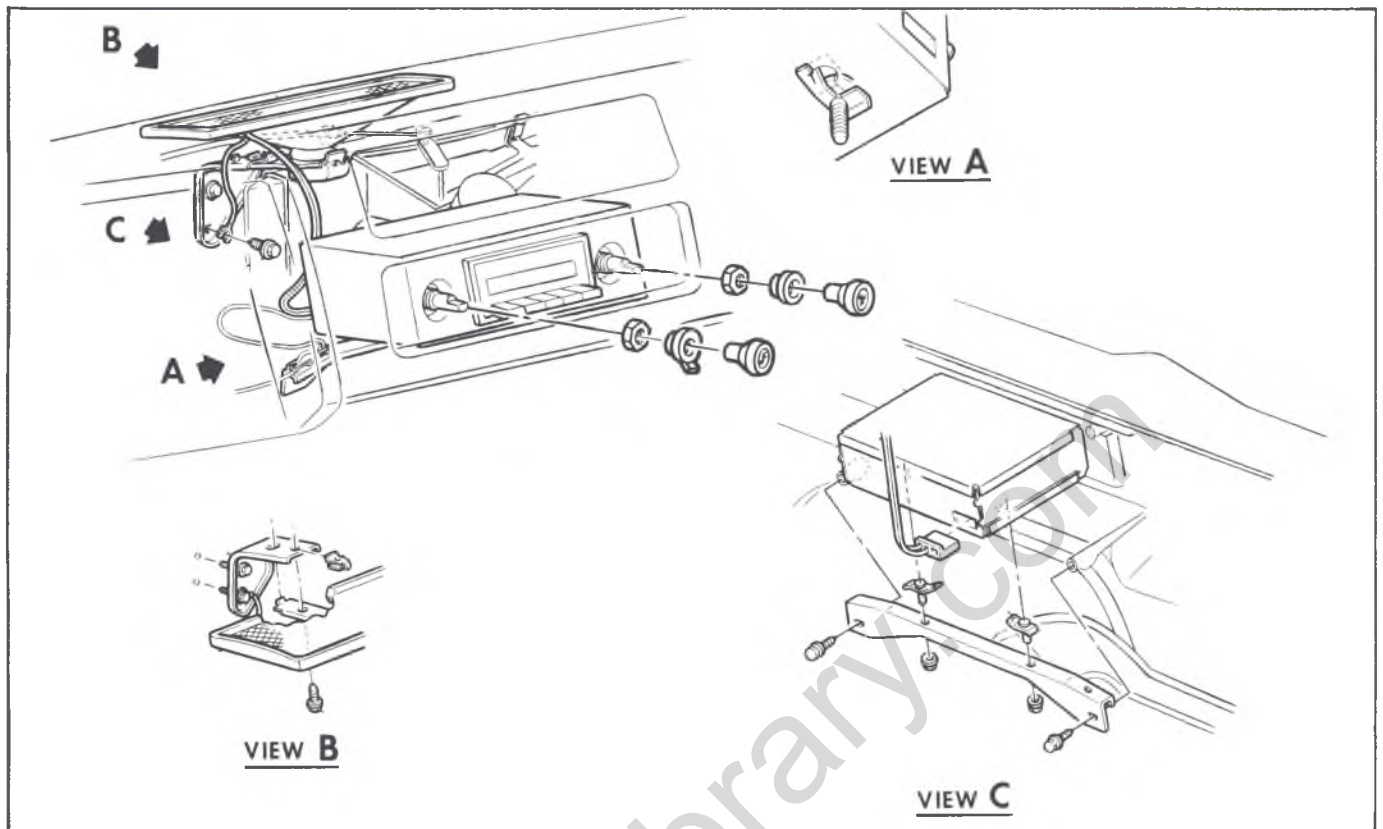

Fig. 3-Radio Installation (G Models)

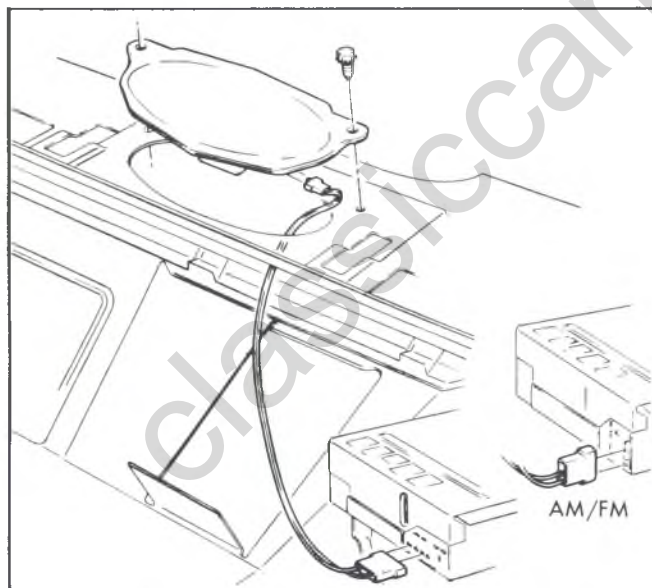

Fig. 4-Radio Speaker (C-K Models)

**SPEAKER**

**C-K Models**

**Replacement (Fig. 4)**

1. Disconnect the battery ground cable.

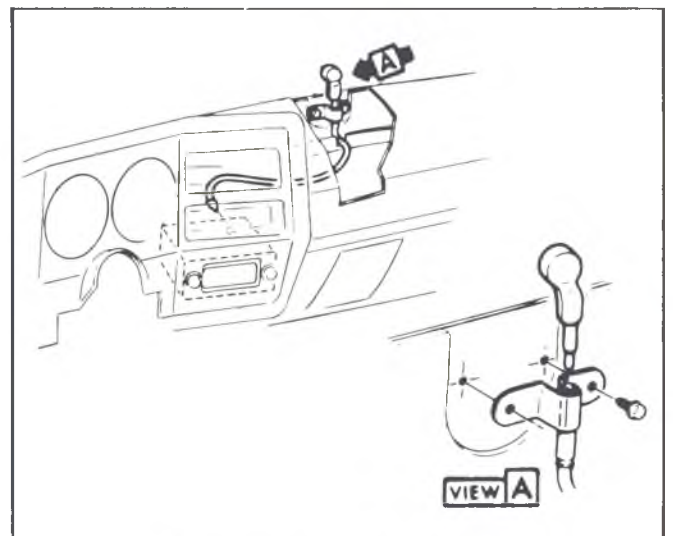

Fig. 5-Antenna Lead (C-K Models)

2. Remove instrument cluster bezel upper (4) screws.
3. Remove the instrument panel pad screws and remove the pad.
4. Remove the speaker to dash panel screws.
5. Lift up on the speaker, disconnect the speaker wiring harness and then remove the speaker.
6. To install, reverse Steps 1-5 above.

## G Models

### Replacement (Fig. 3)

1. Follow radio removal Steps 1 through 8.
2. Remove left heater duct (attached to engine cover extension by one screw).
3. Remove speaker to mounting bracket screw and lower speaker out engine cover opening.
4. Reverse Steps 1-3 above for speaker replacement.

## ANTENNA

### C-K Models (Fig. 5)

#### Antenna Replacement

Refer to Section 1B of this manual "Windshield Replacement" procedure.

#### Cable Replacement

1. Disconnect battery ground cable.
2. Unsnap antenna cable from the windshield.
3. Remove the bracket to dash panel screws.
4. Disconnect the cable at the rear of the radio receiver and remove the cable assembly.

### G Models (Fig. 6)

#### Antenna Replacement

1. Unscrew the mast nut. Holding the cable assembly from turning using two separate wrenches. Remove the rod and mast assembly.
2. To install, insert the rod and mast assembly into the cable assembly and tighten the mast nut. Hold the

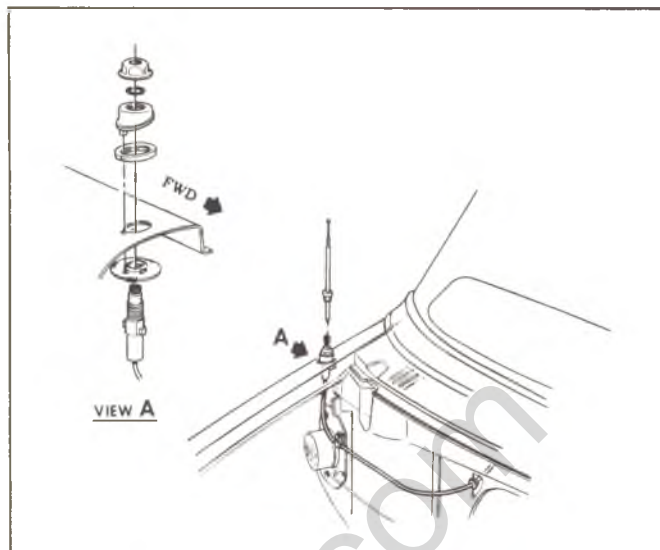

Fig. 6-Antenna Installation (G Models)

cable assembly from turning using a second wrench.

#### Cable Assembly Replacement

1. Disconnect the battery ground cable.
2. Remove the antenna assembly as described above.
3. Remove the cable body nut and then remove the seal, bezel, gasket and ring ground.
4. Perform Steps 2-8 of "Radio Removal".
5. Disconnect the cable at the rear of the receiver.
8. Insert the new cable through the dash panel (from the forward side).
9. Reverse Steps 1-5 above to complete installation.

NOTE: Be sure cable grommet is properly positioned in the dash panel.

## DIAGNOSIS

The radio trouble diagnosis guide is intended as an aid in locating minor faults which can be corrected without a specialized knowledge of radio and without special radio test equipment. If the suggestions given here do not affect a correction, further testing should be done only by a trained radio technician having proper test equipment.

### RADIO DEAD

Turn on radio.

#### No Thump Heard

Check fuse.

**Fuse blown**-Check receiver and speaker connectors.

**Connectors loose or defective**-Correct as required.

**Connectors okay**-Check speaker by substituting a known good speaker.

**Radio does not play even with a known good substitute speaker**-Defective receiver. Remove for servicing.

**Radio plays with substitute speaker**-Replace speaker.

### Thump Heard

Check antenna connection at back of radio and at base of windshield or antenna.

**Connections defective**-Substitute a known good lead-in cable.

**Radio plays**-Defective cable.

**Radio still won't play, even with a known good lead-in cable**-Substitute and trim a known good radio.

**Good radio plays**-Defective radio.

**Good radio still won't play**-Defective antenna.  
Change windshield or antenna.

### RADIO CUTS ON AND OFF

Check for defective or loose receiver or antenna connectors at the rear of radio or base of windshield or antenna.

**Defective or loose connectors**-Repair as necessary.

**Connectors okay**-Substitute a known good lead-in cable.

**Radio plays okay**-Defective cable.

**Radio still cuts out with a known good lead-in cable**-Check speaker by substituting a known good speaker.

**Radio plays okay**-Replace speaker.

**Radio still plays intermittently, even with a known good speaker**-Defective receiver.

### RADIO STATIONS MIX TOGETHER

Trim radio as described earlier in this section. However, if two or more signals are picked up at the same time, there is no known way to separate them.

### RADIO NOISY

Static-Start engine, rev up engine several times, and listen for speaker static.

**Static Heard**-Trim radio - check for spark plug wire breakdown, loose or improperly seated wire, or loose or missing engine ground strap.

Check suppressors on voltage regulator, alternator, and resistor on timing control solenoid.

**Static Still Present**-Defective receiver.

### WEAK RADIO SIGNAL

Test windshield antenna as described under "Antenna Testing" in this section.

### DISTORTED TONE

Turn on radio, adjust for high volume and maximum bass. Check speaker by substituting a good speaker.

**No Distortion**-Replace speaker.

**Distortion**-Defective receiver-remove for servicing.

### TESTING WINDSHIELD ANTENNA (FIG. 7)

All C-K model trucks with factory installed radios are equipped with windshield antennas. To positively identify antenna failure and eliminate the possibility of unnecessary windshield replacement, Windshield Antenna Tester J-23520 should be used to determine the continuity of the thin antenna wire.

When antenna failure is suspected, the following checks should be made before replacing the windshield.

1. Check Tester J-23520 for operation on any vehicle radio antenna that is operating normally to test for a weak or dead battery.
2. Check all antenna connectings to insure that the antenna is electrically coupled to the radio.
3. Turn ignition switch to accessory position, turn radio "ON", select AM band if receiver is AM/FM and tune radio to an off station position.
4. Hold tester to antenna beginning at the upper corner of the antenna:

**CAUTION:** *The plastic Shield must be on the tester at all times to avoid scratching the windshield.*

- a. If a shrill sound is emitted through the speaker when both antenna wires are tested, the antenna is operational.
- b. If no sound is emitted through one or both antenna wires, move the tester along the wire toward the center of the windshield and down toward the radio.
- c. If a shrill sound is picked up, find the exact location where the noise begins, this is the area of the defect. Replace windshield.
- d. If no noise is heard over the entire length of the antenna, unplug the antenna lead at the radio and touch the tester to the antenna socket in the radio.
- e. If the radio now makes a shrill sound, check connectors and antenna lead for possible defect before replacing windshield.
- f. If no noise is emitted, the radio, speaker, or fuse is defective.

**NOTE:** Make sure that the antenna tester is turned off after completing antenna test.



Fig. 7--Testing Windshield Antenna (Typical)



classicalibrary.com

# HEATING AND AIR CONDITIONING

## SECTION 1A

### HEATER

	<u>Volts</u>	<u>Amps. (Cold)</u>	<u>RPM (Cold)</u>
<b>Blower Motor</b>			
C-K Models . . . . .	13.5	6.25 Max.	2550 Min. 2950 Max.
G Models . . . . .	13.5	7.1 Max.	2850 Min. 3250 Max.
<b>Fuses</b>			
C-K Models . . . . .			20 Amp.
G Models . . . . .			20 Amp.

### AUXILIARY HEATER

	<u>Volts</u>	<u>Amps. (Cold)</u>	<u>RPM (Cold)</u>
Blower Motor . . . . .	13.5	9.6 Max.	2700 Min.

### AIR CONDITIONING

<b>Compressor*</b>			
Make . . . . .			Frigidaire
Type . . . . .			6 Cylinder Axial
Displacement . . . . .			12.6 Cu. In.
Rotation . . . . .			Clockwise
	<u>Volts</u>	<u>Amps. (Cold)</u>	<u>RPM (Cold)</u>
<b>Blower Motor</b>			
C-K Four Season . . . . .	12.0	12.8 Max.	3400 Min.
C-K-G Overhead, G Floor and Motor Home Units . . . . .	12.0	13.7 Max.	3400 Min.

### Compressor Clutch Coil

Ohms (at 80°F) . . . . .	3.70
Amps. (at 80°F) . . . . .	3.33 @ 12 volts

### System Capacities

<b>Refrigerant 12</b>	
C-K Four-Season System . . . . .	3 lbs. 12 oz.
C-K-G Overhead Systems . . . . .	5 lbs. 4 oz.
G Model C60 System . . . . .	3 lbs.
Motor Home Chassis Unit . . . . .	3 lbs. 4 oz.

### 525 Viscosity Refrigeration Oil

All except Overhead systems . . . . .	10 oz.
Overhead Systems . . . . .	13 oz.

### Torque Specifications

<b>Compressor Suction and Discharge</b>	
Connector Bolt . . . . .	25 ft. lbs.
Rear Head to Shell Stud Nuts . . . . .	23 ft. lbs.
Shaft Mounting Nut . . . . .	20 ft. lbs.
Compressor Mounting Bracket Bolts . . . . .	25 ft. lbs.
Front Bracket to Compressor Bolts . . . . .	20 ft. lbs.
Belt Tension . . . . .	See Tune Up Chart

### Fuses

<b>Fuse Block—</b>	
C-K Systems . . . . .	25 Amp.
Motor Home Chassis Unit . . . . .	20 Amp.
<b>In-Line—</b>	
C-K Four-Season Systems . . . . .	30 Amp.
C-K Overhead System . . . . .	20 Amp.
Motor Home Chassis Unit . . . . .	None
<b>Circuit Breaker</b>	
G Model Systems . . . . .	35 Amp.

## BODY

### SECTION 1B

#### C AND K MODELS

#### FRONT END

Windshield Wiper Linkage to Plenum . . . . .	25 in. lb.
Sunshade Support . . . . .	20 in. lb.
Inside Rear View Mirror to Bracket . . . . .	45 in. lb.
Outside Rear View Mirror to Door Panel —	
Base Mirror . . . . .	25 in. lb.
West Coast Mirror—Lower Bracket to Door . . . . .	20 in. lb.
—Upper Bracket to Door. . . . .	45 in. lb.

#### DOORS

Window Regulator Assembly to Door Panel . . . . .	85 in. lb.
Remote Control Door Lock to Door Panel . . . . .	45 in. lb.
Lock Striker to Body Pillar . . . . .	45 ft. lb.
Outside Door Handle. . . . .	85 in. lb.
Inside Door Handle . . . . .	85 in. lb.
Hinges to Body and Door . . . . .	35 ft. lb.
Front Door—Window Run Channel	
Upper Screw Assembly . . . . .	85 in. lb.
Lower Bolt Assembly. . . . .	18 in. lb.
Front Door—Ventilator Assembly	
Top Vent Screw . . . . .	18 in. lb.
Side Vent Screws and Spacers . . . . .	25 in. lb.
Lower Vent Channel Bolts . . . . .	40 in. lb.
Side Rear Door—Run Channel	
Front Upper to Door . . . . .	40 in. lb.
Rear Upper to Door . . . . .	20 in. lb.
Front and Rear Lower to Door. . . . .	85 in. lb.
Lock Lever to Door . . . . .	85 in. lb.
Rear Door—Lock Striker (06) . . . . .	95 in. lb.
Rear Door—Latch L.H. and R.H. to Door (06) . . . . .	85 in. lb.
Rear Door—Latch Control Assembly to Door (06)	
—Upper Assembly . . . . .	85 in. lb.
—Lower Assembly . . . . .	90 in. lb.
Rear Door—Weatherstrip L.H. (06) . . . . .	18 in. lb.

#### END GATE (14)

Hinges—Body Half and Gate Half . . . . .	35 ft. lb.
Support Assembly—Body to End Gate . . . . .	25 ft. lb.
Torque Rod—Retainer Assembly. . . . .	85 in. lb.
—Anchor Assembly . . . . .	18 ft. lb.
Latch Assembly to End Gate . . . . .	85 in. lb.
Latch Control Assembly to End Gate . . . . .	40 in. lb.
Access Cover . . . . .	18 in. lb.
Handle to Latch Control Assembly . . . . .	55 in. lb.
Glass Channel Assembly to End Gate . . . . .	85 in. lb.
Cap Assembly to Channel Assembly. . . . .	24 in. lb.
Striker—Body Mounted . . . . .	18 ft. lb.

#### END GATE (06)

Hinges—Hinge to Body . . . . .	35 ft. lb.
—Hinge to End Gate. . . . .	20 ft. lb.
Support Cable Bolts . . . . .	25 ft. lb.
Torque Rod—Silencer Bracket . . . . .	40 in. lb.
—End Support Bracket. . . . .	90 in. lb.
Latch Assembly to End Gate . . . . .	20 ft. lb.
Latch Remote Control Assembly to End Gate . . . . .	40 in. lb.
Access Cover . . . . .	18 in. lb.
Outside Handle . . . . .	55 in. lb.
Glass Channel . . . . .	45 in. lb.

#### TAILGATE (03, 63—with E63)

Trunnion Assembly . . . . .	18 ft. lb.
Linkage and Striker Assembly—Support . . . . .	25 in. lb.

#### TAILGATE (03, 63—with E62)

Trunnion Assembly . . . . .	35 ft. lb.
Chain Support Assembly . . . . .	90 in. lb.

#### SEATS

Front Bench Seat	
Adjuster-to-Seat . . . . .	155 in. lb.
Adjuster-to-Floor . . . . .	25 ft. lb.
Front Bucket Type (14, 03)	
Driver	
Adjuster-to-Seat . . . . .	18 ft. lb.
Adjuster-to-Floor . . . . .	25 ft. lb.
Passenger (03)	
Support-to-Seat . . . . .	18 ft. lb.
Support-to-Floor (Front). . . . .	25 ft. lb.
Support-to-Floor (Rear) . . . . .	40 ft. lb.
Passenger (14)	
Latch Support-to-Seat (Rear) . . . . .	18 ft. lb.
Striker-to-Floor (Rear) . . . . .	25 ft. lb.
Support (Upper)-to-Seat (Front) . . . . .	18 ft. lb.
Support (Lower)-to-Floor (Front) . . . . .	25 ft. lb.
Support (Upper)-to-Support (Lower) . . . . .	30 ft. lb.
Rear Bench (06, 14)	
Support-to-Seat . . . . .	18 ft. lb.
Support-to-Floor . . . . .	50 ft. lb.
Rear Bench (63)	
Support-to-Seat . . . . .	150 in. lb.
Support-to-Floor . . . . .	35 in. lb.
Folding Rear Seat (06)	
Support Asm-to-Floor . . . . .	150 in. lb.
Seat-to-Support Asm . . . . .	18 in. lb.

BODY MOUNTING (C-K MODELS)—FT. LBS.

Model	#1	#2	#3	#4	#5	#6
(03)	45	45	—	—	—	—
(06)	35	35	—	35	—	35
(14)	55	45	35	35	—	—
(63)	55	35	55	—	—	—

**G MODELS**

**MIRRORS AND SUNSHADE**

- Inside Rear View Mirror to Bracket . . . . . 15 in. lb.
- Outside Rear View Mirror to Panel . . . . . 40 in. lb.
- Sunshade Support to Header Panel . . . . . 15 in. lb.

**SIDE WINDOW (SWINGOUT)**

- Latch to Body . . . . . 40 in. lb.
- Latch to Glass . . . . . 40 in. lb.
- Hinge to Body . . . . . 40 in. lb.

**FRONT SIDE DOORS**

- Door Hinges . . . . . 30 ft. lb.
- Door Hinge Access Hole Cover . . . . . 18 in. lb.
- Door Lock Striker . . . . . 45 ft. lb.
- Door Lock to Door . . . . . 20 ft. lb.
- Outside Door Handle . . . . . 45 in. lb.

**REAR DOOR**

- Hinge Strap to Door . . . . . 45 in. lb.
- Hinge Strap Bracket to Body . . . . . 45 in. lb.
- Hinge (to body and door) . . . . . 30 ft. lb.
- Remote Control Retaining Screws . . . . . 85 in. lb.
- Latch-to-Door Retaining Screws . . . . . 90 in. lb.
- Door Strikers-to-Body . . . . . 90 in. lb.
- Outside Door Handle . . . . . 45 in. lb.

**SLIDING SIDE DOOR**

- Remote Control (front latch) to Door . . . . . 90 in. lb.
- Rear Latch to Door . . . . . 90 in. lb.
- Rear Plate to Door . . . . . 90 in. lb.
- Lower Front Roller and Roller Support
  - Support-to-Door . . . . . 24 ft. lb.
  - Support to Roller Bracket . . . . . 24 ft. lb.
  - Roller to Roller Bracket . . . . . 20 ft. lb.
  - Catch to Roller Bracket . . . . . 45 in. lb.
- Upper Front Roller Bracket
  - Bracket to Door . . . . . 24 ft. lb.
  - Roller to Bracket . . . . . 20 ft. lb.
- Upper Left Hinge (Door Half)
  - Hinge to Door . . . . . 25 ft. lb.
- Upper Left Hinge (Body Half)
  - Roller to Hinge . . . . . 20 ft. lb.
  - Guide Block to Hinge . . . . . 40 in. lb.
  - Lever Arm-to-Hinge Retaining Nut . . . . . 120 in. lb.
  - Lever Retaining Screw . . . . . 40 in. lb.
  - Striker to Body . . . . . 20 ft. lb.
- Rear Striker Bolt (Body Mounted) . . . . . 45 ft. lb.
- Front Striker Retaining Screws (Body Mounted) . . 90 in. lb.

**SEATS**

- Seat Belt to Seat . . . . . 37 ft. lb.
- Passenger and Drivers
  - Seat to Adjuster (Mounting Bracket) . . . . . 18 ft. lb.
  - Seat to Riser . . . . . 18 ft. lb.
  - Seat Riser-to-Floor . . . . . 50 ft. lb.
- Bench Seats
  - Seat to Seat Support . . . . . 18 ft. lb.
  - Seat Support to Floor Clamps . . . . . 40 ft. lb.

# FRONT SUSPENSION

## SECTION 3

### \* WHEEL ALIGNMENT SPECIFICATIONS

CASTER **											
Dimension "A" in inches +	2 1/2"	2 3/4"	3"	3 1/4"	3 1/2"	3 3/4"	4"	4 1/4"	4 1/2"	4 3/4"	5"
GA10 - 30 PA 30	+2 1/4°	+2°	+1 1/2°	+1 1/4°	+1°	+3/4°	+1/2°	+1/4°	0°	-1/4°	-1/2°
CA PA 10			+2°	+1 1/2°	+1 1/4°	+1°	+3/4°	+1/2°	+ 1/4°	0°	-1/2°
CA PA 20 - 30	+1 1/2	+1 1/4°	+1°	+3/4°	+1/2°	+1/4°	0°	-1/4°	-1/2°	-3/4°	-1°
K10 - 20	+4° -- no provision for resetting										
PA 10-20	-	-	-	+1 1/2°	+1 1/4°	+1°	+3/4°	+1/2°	+1/4°	0°	-1/4°
<b>CAMBER</b>											
CA GA PA 10 - 20 - 30 .....										+1/4°	
KA 10 - 20 .....										No provision for resetting	
<b>TOE-IN (TOTAL)</b>											
CA GA PA 10 - 20 - 30 K 10 - 20 .....										3/16"††	
K 10-20										0°	

\* See Column 1, 2 or 3 under Vehicle Alignment Tolerances for applicable tolerances.

\*\* See Page 3-15 for the proper method of determining Caster Angle.

+ See Page 3-15 Figure 20 for method of determining Dimension "A".

†† K-10 with full time four wheel drive toe-in = 0".

#### VEHICLE ALIGNMENT TOLERANCES ††

#### VEHICLE INSPECTION TOLERANCES ††

	Field Usage	
	Column 1 *Service Checking	Column 3 @ Service Reset
Camber .....	± 3/4°	± 1/2°
Caster .....	± 1°	± 1/2°
\$ Toe-in .....	± 1/8"	± 1/16"
Camber (Side to Side) .	1°	1/2°
Caster (Side to Side) . .	1°	1/2°

	Column 2
Caster .....	± 2°
Camber .....	± 1 1/2°
Toe .....	± 3/8"

\* Caster and Camber must not vary more than 1° from side to side.

@ Caster and Camber must not vary more than 1/2° from side to side.

\$ Toe setting must always be made after caster and camber.

†† See explanatory copy in front suspension section 3 Page 14.

## FRONT SUSPENSION BOLT TORQUE (Ft. Lbs.) \$

	CP-10	CP-20-30	K-All	G-10-20	G-30
Lower Control Arm Shaft U-Bolt	45	85	—	45	85
Upper Control Arm Shaft Nuts	70	105	—	70	105
Control Arm Rubber Bushings	140	—	—	140	
Upper Control Arm Bushing Steel \$\$		New 190 Used 115	—	w/Spacer 160 No Spacer 95	w/Spacer 190 No Spacer 115
Lower Control Arm Bushing Steel \$\$		New 280 Used 130	—	w/Spacer 280 No Spacer 130	w/Spacer 280 No Spacer 130
Upper Ball Joint Nut	*50	**90	**100	*50	**90
Lower Ball Joint Nut	**90	**90	***80	**90	**90
Crossmember to Side Rail	65	65	—	65	65
Crossmember to Bottom Rail	100	100	—	100	100
Crossmember Brake Support Struts		60			60
Stabilizer Bar to Control Arm	25	25	ANCHOR PLATE - 130		25
Stabilizer Bar to Frame	25	25	.55		25
Shock Absorber Upper End	140	140	65		75
Shock Absorber Lower End	60	60	65		75
Brake Splash Shield to Knuckle	120 In. Lbs.	120 In. Lbs.	120 In. Lbs.		120 In. Lbs.
Wheel Bearing Adjustment	—	—	Inner # - 35 Outer - 50		—
Wheel Bearing Preload	Zero	Zero	Zero		Zero
Wheel Bearing End Movement	.001 - .005"	.001 - .005"	.001 - .010"		.001 - .005
Caliper Mounting Bolt	35	35	35		35
Spring - Front Eye Bolt	—	—	90		—
Spring - Rear Eye Bolt	—	—	50		—
Spring - To Rear Shackle Bolt	—	—	50		—
Spring - To Axle U-Bolt	—	—	150		—
Spring - Front Support to Frame	—	—	25		—
Suspension Bumper	15	15	25		15
Stabilizer to Spring Plate	—	—	130		—

\* Plus additional torque to align cotter pin. Not to exceed 90 ft. lbs. maximum.

\*\* Plus additional torque to align cotter pin. Not to exceed 130 ft. lbs. maximum.

\*\*\* Plus additional torque to align cotter pin.

# Back nut off to align cotter pin at nearest slot.

\$ All specifications are given in foot pounds of Torque unless indicated otherwise.

\$\$ C10, G10-20 Rubber Bushings; C20-30, G30, P10-30 Steel Bushings.

## FOUR WHEEL DRIVE

Axle	5500# (Dana)		Bolt Torques (Ft. Lbs.)
Gear Backlash Preferred	.004" - .009"	Carrier Cover	35
Min. and Max.	.004" - .009"	Ring Gear	110
New Pinion Bearing Preload	20-40 in. lbs.	Differential Bearing Caps	85
Used Pinion Bearing Preload	10-20 in. lbs.	Filler Plugs	10
		Drive Pinion Nut	255
		Brake - Backing Plate	35
		Axle Shaft To Hub Bolts	60

# REAR SUSPENSION

## SECTION 4

### TORQUE SPECIFICATIONS (FT. LBS.)

#### WHEEL BEARING ADJUSTMENT SPECIFICATIONS

Ring Gear Size	Bearing Adjusting Nut Torque*	Adjusting Nut Back-off*	Outer Locknut Torque	Resulting Bearing Adjustment	Type of Bearing
10-1/2" and 9-3/4"	50 Ft. Lbs.	**	65 Ft. Lbs.	.001 to .010 End Play	Tapered Roller
12-1/4"	75-100 Ft. Lbs.	1/8 *	250 Ft. Lbs.	Slight Preloaded	Barrel Roller

\*\* Back-off nut and retighten to 35 Ft. Lbs. then, back-off nut 1/4 turn.

\* With wheel rotating.

UNIVERSAL JOINT ATTACHMENT TORQUE SPECIFICATIONS	
Strap Attachments . . . . .	15 Ft. Lbs.
"U" Bolt Attachment. . . . .	20 Ft. Lbs.

Ring Gear Size	Lubricant Capacity
8-7/8"	3.5 Pints
Chevrolet 10-1/2"	5.4 Pints
Dana 10-1/2"	7.2 Pints
Dana 9-3/4	6.0 Pints
12-1/4"	14.0 Pints

#### DIFFERENTIAL SPECIFICATIONS

	8-7/8"	10-1/2" Dana 9-3/4"	10-1/2" Chevrolet	12-1/4"
Gear Backlash Preferred	.005"-.008"	.004"-.009"	.005"-.008"	.005"-.008"
Min. and Max.	.003"-.010"	.004"-.009"	.003"-.012"	.003"-.012"
Pinion Bearing Preload (In. Lbs.)				
New	20-25	20-40	25-35	
Used	5-10	10-20	5-15	

	8-7/8"	10-1/2" Dana 9-3/4"	10-1/2" Chevrolet	12-1/4"
Filler Plugs	18	10	18	10
Differential Pinion Lock	25	—	—	—
Drive Pinion Nut	—	255	220	220
Differential Carrier to Axle Housing	—	—	45	85
Differential Bearing Adjusting Lock	—	—	15	15
Pinion Bearing Cage To Carrier	—	—	70	165
Thrust Pad Lock Nut	—	—	—	135
Brake - Backing Plate	40	105	105	155
Axle Shaft To Hub Bolts	—	90	90	15

#### Bolt Torques (Ft. Lbs.)

	8-7/8"	10-1/2" Dana 9-3/4"	10-1/2" Chevrolet	12-1/4"
Carrier Cover	23	35	18	—
Ring Gear	50	110	110	105
Differential Bearing Caps	55	85	100	205

\*Initial Torque Only, Additional Torque as necessary.

## TORQUE SPECIFICATIONS (FT. LBS.) (CONT'D.)

	C-K	G	P
Spring-to-Axle "U" Bolt Nuts	140	120(GP,20) 140(G30)	140
Leaf Spring			
—Front Bushing Bolt	90	135	90
—Rear Shackle Bolt	90	135	90
Shock Absorber			
—Upper Attachment	140	75	140
—Lower Attachment	115	75	115
Propeller Shaft			
To Rear Axle (Strap)	12-17	12-17	12-17
To Rear Axle ("U" Bolt)	18-22	—	18-22
Bearing Support-to-Hanger	20-30	20-30	20-30
Hanger-to-Frame	40-50	—	—
Rear Stabilizer-to-Anchor Plate	20-30	—	20-30



# BRAKES

## SECTION 5 TORQUE SPECIFICATIONS

	C	K	G	P
Master Cylinder to Dash or Booster . . . . .			25 ft. lbs.	
Booster to Dash or Frame . . . . .			25 ft. lbs.	
Brake Line to Master Cylinder . . . . .			150 in. lbs.	
Brake Line to Combination Valve . . . . .			150 in. lbs.	
Brake Line to Flex Hose . . . . .			150 in. lbs.	
Combination Valve Mounting Nuts . . . . .			150 in. lbs.	
Combination Valve Bracket to Frame . . . . .	—	—	—	25 ft. lbs.
Flex Hose to Caliper . . . . .			22 ft. lbs.	
Rear Line to Wheel Cylinder . . . . .			150 in. lbs.	
Rear Line to Connector or Unions . . . . .			115 in. lbs.	
Rear Flex Hose to Connector . . . . .	115 in. lbs.	115 in. lbs.	150 in. lbs.	150 in. lbs.
Front Brake Hose to Frame Nut . . . . .	150 in. lbs.	58 in. lbs.	58 in. lbs.	58 in. lbs.
Front Brake Hose Bracket Bolt . . . . .	58 in. lbs.	—	150 in. lbs.	150 in. lbs.
Brake Hose Bracket to Axle Housing . . . . .	150 in. lbs.	150 in. lbs.	—	150 in. lbs.
Brake Hose to Bracket at Axle Housing . . . . .	150 in. lbs.	150 in. lbs.	90 in. lbs.	150 in. lbs.
Brake Line Clips . . . . .	150 in. lbs.	150 in. lbs.	100 in. lbs.	150 in. lbs.
Push Rod to Pedal . . . . .	—	—	—	25 ft. lbs.
Push Rod Adjusting Nut . . . . .			25 ft. lbs.	
Brake Pedal Bolt Nut . . . . .	25 ft. lbs.	25 ft. lbs.	20 ft. lbs.	45 ft. lbs.
Brake Pedal Sleeve to Bracket . . . . .	—	—	—	100 in. lbs.
Stoplamp Switch Bracket to Pedal . . . . .	25 ft. lbs.	25 ft. lbs.	25 ft. lbs.	—
Pedal Bracket to Dash . . . . .	25 ft. lbs.	25 ft. lbs.	120 in. lbs.	25 ft. lbs.
Hydro-Boost Pedal Rod — P30(32) Models . . . . .	—	—	—	25 ft. lbs.
Hydro-Boost Pedal Rod — P30(32) Models . . . . .	—	—	—	15 in. lbs.
Parking Brake Assembly to Dash . . . . .	100 in. lbs.	100 in. lbs.	100 in. lbs.	—
Parking Brake Assembly to I.P., Kick Panel or Floorpan . . . . .	150 in. lbs.	150 in. lbs.	100 in. lbs.	18 ft. lbs.
Parking Brake Cable to Assembly Clip . . . . .	—	—	18 ft. lbs.	—
Cable Clips to Frame . . . . .	—	—	150 in. lbs.	150 in. lbs.
Equalizer Nuts . . . . .	—	—	—	18 ft. lbs.
Prop Shaft Parking Brake Adjusting Nut . . . . .	—	—	—	25 ft. lbs.
Prop Shaft Parking Brake Cable Bracket to trans. . . . .	—	—	—	25 ft. lbs.
Prop Shaft Parking Brake Cable Clip . . . . .	—	—	—	20 ft. lbs.
Rear Brake Anchor Pin . . . . .			140 ft. lbs.	
Caliper Mounting Bolt . . . . .			35 ft. lbs.	
Support Plate to Knuckle . . . . .			140 in. lbs.	
Wheel Cylinder to Flange Plate Bolt . . . . .			50 in. lbs.	
Hydro-Boost Accumulator . . . . .			20 ft. lbs.	
Accumulator Inlet Line . . . . .			140 in. lbs.	
Accumulator Outlet Line . . . . .			165 in. lbs.	
Hydro-Boost Inlet, Outlet and Return Lines . . . . .			25 ft. lbs.	
Hydro-Boost Pivot Lever Bolt . . . . .			40 ft. lbs.	
Hydro-Boost Brace . . . . .	—	—	150 in. lbs.	150 in. lbs.
Hydro-Boost Push Rod Retainer Bracket . . . . .	—	—	150 in. lbs.	25 ft. lbs.
Brake Bleeder Valves . . . . .	Torque to seal or 100 in. lbs. max. Replace valve if it will not seal at 100 in. lbs.			

# ENGINE

## SECTION 6

GENERAL DATA:									
Type		In Line		V8					
Displacement (cu. in.)		250	292	350		454			
Horsepower @ rpm		100 @ 3600	120 @ 3600	145 @ 3600	160 @ 3800	230 @ 4000	245 @ 4000		
Torque @ rpm		175 @ 1800	215 @ 2000	250 @ 2200	255 @ 2400	350 @ 2800	365 @ 2800		
RPO		LD4	L25	LF5	LS9	LF8			
Carburetor		1BBL.	1BBL.	2BBL.	4BBL.	4BBL.			
Bore		3 7/8		4		4 1/4			
Stroke		3.53	4.12	3.48		4			
Compression Ratio		8.25:1	8.0:1	8.5:1		8.25:1			
Firing Order		1-5-3-6-2-4		1-8-4-3-6-5-7-2					
CYLINDER BORE:									
Diameter		3.8745 - 3.8775		3.9995 - 4.0025		4.2495 - 4.2525			
Out of Round	Production	.0005 Max.		.001 Max					
	Service	.002 Max.							
Taper	Production	Thrust Side	.0005 Max.						
		Relief Side	.0005 Max.		.001 Max.				
	Service	.005 Max.							
PISTON:									
Clearance	Production	.0005-.0015	.0026-.0036	.0007-.0013		.0018-.0028			
	Service	.0025 Max.		.0045 Max.		.0027 Max.			
PISTON RING:									
COMPRESSION	Clearance Groove	Production	Top	.0012 - .0027	.0020-.0040	.0012 - .0032		.0017 - .0032	
			2nd	.0012-.0032					
			Service	Hi Limit Production + .001					
	Gap	Production	Top	.010 - .020					
2nd			.010 - .020	.013 - .025		.010 - .020			
		Service	Hi Limit Production + .01						
OIL	Groove Clearance	Production	.005 Max.	.005-.0055	.002 - .007		.0005 - .0065		
		Service	Hi Limit Production + .001						
	Gap	Production	.015 - .055				.010 - .030		
		Service	Hi Limit Production + .01						
PISTON PIN:									
Diameter		.9270 - .9273				.9895 - .9898			
Clearance	Production	.00015 - .00025				.00025 - .00035			
	Service	.001 Max.							
Fit in Rod		.0008 - .0016 Interference							

**SPECIFICATIONS 10**

CRANKSHAFT:						
Main Journal	Diameter	All 2.2983 - 2.2993		#1-2-3-4 2.4484 - 2.4493	#1 2.7485 - 2.7494	
				#5 2.4479 - 2.4488	#2-3-4 2.7481 - 2.7490	
					#5 2.7478 - 2.7488	
	Taper	Production	.0002 (Max.)			
		Service	.001 (Max.)			
Out of Round	Production	.0002 (Max.)				
	Service	.001 (Max.)				
Main Bearing Clearance	Production	All .0003	All .0008	#1 .0008 - .0020	#1-2-3-4 .0013 - .0025	
		— .0029	— .0034	#2-3-4 .0011 - .0023	#5 .0024 - .0040	
		Service #1 - .002 (Max.) All Others .0035 (Max.)				
Crankshaft End Play				.002 - .006		.006 - .010
Crank-pin	Diameter	1.999 - 1.2000	2.099 - 2.100	2.199 - 2.200	2.1985 - 2.1995	
		Taper				
	Production		.0003 (Max.)			
	Service		.001 (Max.)			
Out of Round	Production		.0002 (Max.)			
	Service		.001 (Max.)			
Rod Bearing Clearance	Production		.0007 - .0027		.0013 - .0035	
	Service				.0035 (Max.)	
Rod Side Clearance		.0006 - .0017		.008 - .014		.013 - .023
CAMSHAFT:						
Lobe Lift ± .002"	Intake	.2217	.2315	.2600	.2343	
	Exhaust	.2217	.2315	.2733	.2343	
Journal Diameter				1.8682 - 1.8692		1.9482 - 1.9492
Camshaft Runout				.0015 Max.		
Camshaft End Play				.001 - .005 (In-Line Engine)		
VALVE SYSTEM:						
Lifter				Hydraulic		
Rocker Arm Ratio		1.75:1		1.50:1		1.70:1
Valve Lash	Intake	One Turn Down From Zero Lash				
	Exhaust					
Face Angle (Int. & Exch.)				45°		
Seat Angle (Int. & Exh.)				46°		
Seat Runout (Int. & Exh.)				.002 (Max.)		
Seat Width	Intake	1/32 - 1/16				
	Exhaust	1/16 - 3/32				
Stem Clearance	Production	Int.	.0010 - .0027			
		Exh.	.0015 - .0032		.0010 - .0027	
	Service		Hi Limit Production + .001 Intake - + .002 Exhaust			
Valve Spring (Outer)	Free Length		190		Exhaust 1.91	Inlet 2.03
	Pressure lbs. @ in.	Closed	55-64 @ 1.66	85-93 @ 1.69	76-84 @ 1.61	76-84 @ 1.70
		Open	180-192 @ 1.27	174-184 @ 1.30	183-195 @ 1.20	194-206 @ 1.25
Installed Height ± 1/32"		1-21/32	1-5/8	1-5/8	1-23/32	1-7/8
Damper	Free Length		—		1.94	
	Approx. # of Coils		—		4	

TUNE-UP CHART

ENGINE	Type		In Line		V8		
	Displacement		250	292	350		454
	Horsepower		100	120	145	160	230 & 245
COMPRESSION ①			130 psi		150 psi		
SPARK PLUG	Make & Number	Standard	AC-R46T	AC-R44T	AC-R44T		
		Cold	AC-R45T	AC-R43T			
Gap			.035"				
DISTRIBUTOR ②	Point Dwell		31°-34°		29°-31°		
	Point Gap		.016" (Used) .019" (New)				
	Arm Spring Tension		19-23 ounces				
	Condenser		.18-.23 microfarad				
	Timing ③	Syn.	L.D.	See Idle Mixture Specifications			
H.D.							
Auto.		L.D.					
		H.D.					
DRIVE BELT ④	Fan P/S and Air Pump		50 lb. Min. 75 ± 5 lbs. (Used) 125 ± 5 lbs. (New) Using Strand Tension Gauge				
	A/C Compressor		65 lbs. Min. 95 ± 5 lbs. (Used) 140 ± 5 lbs. (New) Using Strand Tension Gauge				
AIR CLEANER			See Note ⑤				
VALVE LASH			Hydraulic — 1 turn down from zero lash				
IDLE RPM ⑥	Syn.	L.D.	850	—	900	900	800
		H.D.	600	600	—	600	700
	Auto.	L.D.	600	—	600	600	600
		H.D.	600	600	—	600	700
FUEL PUMP ⑦	Pressure in lbs.		3-1/2 to 4-1/2		7 to 8-1/2		
	Volume		1 pint in 30-45 seconds @ cranking speed				
CRANKCASE VENTILATION			Check at 12,000 Miles/Replace at 24,000 Miles				

- ① PSI at Cranking Speed, throttle wide open — Maximum variation, 20 PSI between cylinders.
- ② Rotate cam lubricator 180° at 12,000 mile intervals — Replace at 24,000 mile intervals.
- ③ At idle speed with vacuum advance line disconnected and plugged. On Step Van vehicles, use number two cylinder and timing tab on bottom of cover. B — B.T.D.C.
- ④ Do not pry against A.I.R. pump housing.
- ⑤ CAUTION: In addition to its function of filtering air drawn into the engine through the carburetor, the air cleaner also acts as a flame arrestor in the event the engine backfires. Because backfiring may cause fire in the engine compartment, the air cleaner should be installed at all times unless its removal is necessary for repair or maintenance services.  
 Paper Element Type — First 12,000 miles, inspect element for dust leaks, holes, or other damage and replace if necessary. If satisfactory, rotate element 180° from original installation position. Replace element at 24,000 miles. Element must not be washed, oiled, tapped, or cleaned with an air hose. If so equipped, replace P.C.V. breather filter every 24,000 miles (do not attempt to clean). If so equipped, clean wire mesh frame arrestor every 12,000 miles.  
 Oil Bath Type — The oil level in the oil bath air cleaner reservoir should be checked every 12,000 miles and sufficient S.A.E. 50 oil added when temperature is above freezing or S.A.E. 20 oil added when temperature is below freezing. Adding oil and servicing the cleaner will vary greatly, depending upon operating conditions.  
 Oil Wetted Paper Element With Polyurethane Wrap — This dual element air cleaner has extremely long life and will not require replacement for 50,000 to 100,000 miles under normal operating conditions. Cleaning and oiling of the polyurethane wrap should be done at 24,000 miles under normal highway or city-type operation. Service under off-the-road or extremely dusty operations should be performed at 12,000 miles or less depending upon severity of operating conditions.
- ⑥ See "TUNE-UP" section.
- ⑦ Replace filter element located in carburetor inlet every 12 months or 12,000 miles, whichever occurs first.  
 \* 2°B on C20 Suburban Models. L.D. All 10 Series: C-K20 Suburban; All G20 Series and G30 Sportvans.  
 H.D. All C-K20 Series except C-K20 Suburban; All C-P30 Series and all G30 Series except Sportvans.

**IDLE MIXTURE ADJUSTMENT SPECIFICATIONS  
LIGHT DUTY EMISSION VEHICLES**

**GM 102 250 CU. IN. – FEDERAL**

**TRANSMISSION**

	<b>Automatic</b>	<b>Manual</b>
Exhaust Emission Control System	CCS-EGR	AIR-EGR
Timing (°BTC @ RPM)	8° @ 600	8° @ 850
Solenoid Adj. (RPM)	600 (DR)	850 (N)
Lean Drop Idle Mixture (RPM)	650/600 (DR)	950/850 (N)

**GM 102 250 CU. IN. – CALIFORNIA**

**TRANSMISSION**

	<b>Automatic</b>	<b>Manual</b>
AIR-EGR Exhaust Emission Control		
Timing (°BTC @ RPM)		8° @ 850
Solenoid Adj. (RPM)	N/A	850 (N)
Lean Drop Idle Mixture (RPM)		950/850 (N)

**GM 104-2 350 CU. IN. 2 BBL – FEDERAL**

**TRANSMISSION**

	<b>Automatic</b>	<b>Manual</b>
AIR-EGR Exhaust Emission Control		
Timing (°BTC @ RPM)	8° @ 600	0° @ 900
Solenoid Screw (RPM)	600 (DR)	900 (N)
Lean Drop Idle Mixture (RPM)	650/600 (DR)	1000/900 (N)

**GM 104-4 350 CU. IN. 4BBL FED. (EXC. C-K 10 & 20 SUBURBAN AND G20 & 30 SPORTVANS)**

**TRANSMISSION**

	<b>Auto. Exc. Versavan (COPO)</b>	<b>Auto Versavan (COPO)</b>	<b>Manual</b>
Exhaust Emission Control System	CCS-EGR	AIR-EGR	AIR-EGR
Timing (°BTC @ RPM)	8° @ 600	8° @ 600	8° @ 900
Solenoid Screw (RPM)	600 (DR)	600 (DR)	900 (N)
Lean Drop Idle Mixture (RPM)	650/600 (DR)	630/600 (DR)	950/900 (N)

**GM 104-4 350 CU. IN. 4BBL FED. C-K 10 & 20 SUBURBANS AND G20 & 30 SPORTVANS**

**TRANSMISSION**

	<b>Auto</b>	<b>Manual Exc. Suburban</b>	<b>Manual Suburban</b>
AIR-EGR Exhaust Emission Control			
Timing (°BTC @ RPM)	12° @ 600	8° @ 900	6° @ 900
Solenoid Screw (RPM)	600 (DR)	900 (N)	900 (N)
Lean Drop Idle Mixture (RPM)	630/600 (DR)	950/900 (N)	950/900 (N)

**GM 104-4 350 CU. IN. 4BBL CAL.**

**TRANSMISSION**

	<b>Auto Exc. Suburban</b>	<b>Auto Suburban</b>	<b>Manual</b>
AIR-EGR Exhaust Emission Control			
Timing (°BTC @ RPM)	8° @ 600	6° @ 600	4° @ 900
Solenoid Screw (RPM)	600 (DR)	600 (DR)	900 (N)
Lean Drop Idle Mixture (RPM)	630/600 (DR)	630/600 (DR)	950/900 (N)

**GM 105 454 CU. IN. – NATIONWIDE**

**TRANSMISSION**

	<b>Automatic</b>	<b>Manual</b>
AIR-EGR Exhaust Emission Control		
Timing (°BTC @ RPM)	10° @ 600	10° @ 800
Solenoid Screw (RPM)	600 (DR)	800 (N)
Lean Drop Idle Mixture (RPM)	630/600 (DR)	850/800 (N)

## IDLE MIXTURE ADJUSTMENT SPECIFICATIONS

HEAVY DUTY EMISSION VEHICLES

Family	Engine (CID)	Idle Speed (RPM)	Timing (°BTC)	Lean Drop Settings (RPM)
GM111	250	600	6	700/600
GM112	292	600	8	700/600
GM113	350/4bbl	600	4	750/600
GM115	454	700	8	800/700

IDLE CO ADJUSTMENT SPECIFICATIONS

**NOTE:** Idle Speed and Timing Adjustment Specifications are the same for both lean drop and idle CO settings.

LIGHT DUTY EMISSION VEHICLES

	Max. Acceptable CO Level (%)	If Over Max. Acceptable Level Reset to (% or Less)
GM 102 (250 cu. in.)	.3	.3 or below
GM 104-2 (350 cu. in.)	.5	.5 or below
GM 104-4 (350 cu. in.)	.5	.5 or below
GM 105 (454 cu. in.)	.5	.5 or below

HEAVY DUTY EMISSION VEHICLES

Engine Family	Max. Acceptable CO Level (%) @ Level	If Over Max. Acceptable Level Reset to (% or Less)
GM 111 (250 cu. in.)	2.0	2.0
GM 112 (292 cu. in.)	0.3	0.3
GM 113 (350 cu. in. 4bbl)	0.5	0.5
GM 115 (454 cu. in.)	0.5	0.5

ENGINE TORQUES

Size	Usage	In Line		Small V-8	Mark IV V-8
		250	292	350	454
1/4-20	Camshaft Thrust Plate	80 lb. in.			
	Crankcase Front Cover			80 lb. in.	
	Flywheel Housing Cover			80 lb. in.	
	Oil Filler Bypass Valve				80 lb. in.
	Oil Pan (To Crankcase)		80 lb. in.		
	Oil Pan (To Front Cover)	50 lb. in.			55 lb. in.
	Oil Pump Cover	70 lb. in.			80 lb. in.
	Rocker Arm Cover		45 lb. in.		50 lb. in.
11/32-24	Connecting Rod Cap	35 lb. ft.			
5/16-18	Camshaft Sprocket				20 lb. ft.
	Clutch Pressure Plate	20 lb. ft.			
	Oil Pan (To Crankcase)	75 lb. in.		65 lb. in.	135 lb. in.
	Oil Pump	115 lb. in.			
	Push Rod Cover	50 lb. in.			
	Water Pump	15 lb. in.			
3/8-16	Clutch Pressure Plate			35 lb. ft.	
	Distributor Clamp			20 lb. ft.	
	Flywheel Housing			30 lb. ft.	
	Manifold (Exhaust)				20 lb. ft. ①
	Manifold (Exhaust to Inlet)	30 lb. ft.			
	Manifold (Inlet)				30 lb. ft.
	Manifold-to-head	35 lb. ft.			
	Thermostat Housing	30 lb. ft.			
	Water Outlet			30 lb. ft.	
Water Pump				30 lb. ft.	
3/8-24	Connecting Rod Cap		40 lb. ft.	45 lb. ft.	50 lb. ft.
7/16-14	Cylinder Head			65 lb. ft.	80 lb. ft.
	Main Bearing Cap	65 lb. ft.		70 lb. ft.	
	Oil Pump				65 lb. ft.
	Rocker Arm Stud				50 lb. ft.
7/16-20	Flywheel	60 lb. ft.		60 lb. ft.	65 lb. ft.
	Torsional Damper		60 lb. ft.		
1/2-13	Cylinder Head	95 lb. ft.			
	Main Bearing Cap				110 lb. ft.
1/2-14	Temperature Sending Unit			20 lb. ft.	
1/2-20	Torsional Damper				85 lb. ft.
	Oil Filter		Hand Tight		25 lb. ft.
	Oil Pan Drain Plug			20 lb. ft.	
	Flywheel		110 lb. ft.		
14mm	5/8	Spark Plug		15 lb. ft.	

① Inside bolts on 350 engine 30 lb. ft.

**CARBURETOR**  
SECTION 6M  
IDENTIFICATION  
TRUCKS

VEHICLES				ENGINE				TRUCK CARBURETORS			
TYPE				Displacement and Type	RPO	BBL.	Throttle Lever Ball Stud Location	FEDERAL		CALIFORNIA	
C	K	P	G					Manual	Auto.	Manual	Auto.
10-20*	10-20*	10	10-20-30*	250 L-6	LD-4	1	None	7044021	7044022	7044321	N/A
20-30\$	20\$	20-30	30\$	250 L-6	LD-4	1	None	7044025	7044025	F	F
20-30\$	20\$	20-30		292 L-6	L-25	1	None	7044026	7044026	F	F
10	10			350 V-8	LF-5	2	Upper	7044113	7044114	N/A	N/A
			10	350 V-8	LF-5	2	None	7044123	7044124	N/A	N/A
10#	10#			350 V-8	LS-9	4QJ	Upper	7044203	7044202	7044503	7044502
10*-20*	10*-20*			350 V-8	LS-9	4QJ	Upper	7044503	7044502	7044503	7044502
			10#-20#	350 V-8	LS-9	4QJ	Lower	7044219	7044218	7044519	7044518
			10*20*30*	350 V-8	LS-9	4QJ	Lower	7044219	7044224	7044519	7044518
20\$-30\$	20\$			350 V-8	LS-9	4QJ	Upper	7044213	7044213	7044513	7044513
		20-30		350 V-8	LS-9	4QJ	Lower	7044216	7044216	7044516	7044516
			30\$	350 V-8	LS-9	4QJ	Lower	7044214	7044214	7044514	7044514
		30M		350 V-8	LS-9	4QJ	Upper	7044215	7044215	7044515	7044515
10				454 M-4	LF-8	4QJ	Upper	N/A	7044223	7044512	7044500
20\$-30\$		30M		454 M-4	LF-8	4QJ	Upper	7044212	7044212	N/A	7044512
		30		454 M-4	LF-8	4QJ	Lower	N/A	7044217	N/A	7044517
20*				454 M-4	LF-8	4QJ	Upper	N/A	7044220	N/A	7044520

- NOTES: (\*) "C" - "K" Suburbans & "G" Sport Vans (A.I.R. Light Duty)  
 (F) Same as Federal  
 (\$) "C" - "K" 03 Series and "G" 05 Series (Heavy Duty)  
 (V) Virginia School Bus  
 (M) Motor Home  
 (#) "C" - "K" Except Suburban and "G" Except Sport Vans (C.C.S. Light Duty)



**ADJUSTMENTS**  
**TRUCKS**  
Rochester Carburetors

Model	NUMBER (A) Automatic Trans. (M) Manual Trans.	Float Level	Float Drop	Metering Rod	Pump Rod	Choke Rod (Fast Idle Cam 2nd Step)	Air Valve Wind-Up	Choke Vacuum Break	Choke Unloader
MV	7044021(M)	.295		.080		.275		.350	.500
MV	7044022(A)	.295		.080		.245		.300	.500
MV	7044321(M)	.295		.080		.300		.375	.500
MV	7044025(AM)	1/4		.070		.245		.300	.521*
MV	7044026(AM)	1/4		.070		.275		.350	.521*
2GV	7044113(M)	19/32	1 9/32		1 9/32	.200		.140	.250
2GV	7044114(A)	19/32	1 9/32		1 3/16	.245		.130	.325
2GV	7044123(M)	19/32	1 9/32		1 9/32	.200		.140	.250
2GV	7044124(A)	19/32	1 9/32		1 3/16	.245		.130	.325
4QJ	7044202 & 5Q2	1/4			13/32(*)	.430	7/8	.230	.450
4QJ	7044203 & 503	1/4			13/32(*)	.430	7/8	.230	.450
4QJ	7044218 & 518	1/4			13/32(*)	.430	7/8	.215	.450
4QJ	7044219 & 519	1/4			13/32(*)	.430	7/8	.215	.450
4QJ	7044213 & 513	11/32			13/32(*)	.430	7/8	.215	.450
4QJ	7044223 (227)	.675			13/32(*)	.430	7/16	.220	.450
4QJ	7044212 (217)	.675			13/32(*)	.430	7/16	.230	.450
4QJ	7044512 (517)	.675			13/32(*)	.430	7/16	.230	.450
4QJ	7044500 (520)	.675			13/32(*)	.430	7/16	.250	.450
4QJ	7044224	11/32			13/32(*)	.430	7/8	.215	.450
4QJ	7044214 & 514	11/32			13/32(*)	.430	7/8	.215	.450
4QJ	7044215 & 515	11/32			13/32(*)	.430	7/8	.215	.450
4QJ	7044216 & 516	11/32			13/32(*)	.430	7/8	.215	.450

\* Measured at top of choke blade

**FAST IDLE (RUNNING) RPM ADJUSTMENT**

Carburetors — Rochester

Vehicles	MV		4QJ		2GV	
	Auto.	Man.	Auto.	Man.	Auto. and Manual	
All Trucks	1800 a, b		(M4)#†c	#†c	Advisory Setting	These settings are approximate with low idle at 500 RPM, as specified — with viscous clutch fans disengaged.
	2400 a † %		1600† a.	(**) a.	†1600 (1-1/2 S.A.E)	

†With vacuum advance without EGR signal

a. On high step

# On M4, 1600 RPM for both Auto. and Manual except 7044212, 217, 512, 517, which is 1700 RPM

(\*\*) L/D Truck — Manual, Q-Jet — 1300 RPM w/o Vac. Advance  
H/D Truck — Manual, Q-Jet — 1600 RPM with Vac. Advance

b. w/o Vac. Advance, w/o EGR

% 7044025 & 7044026 only

c. w/o EGR, vacuum plugged on EGR equipped units

**IDLE MIXTURE ADJUSTMENT**  
 – LEAN DROP METHOD –  
 (REFER TO SERVICE MANUAL IDLE MIXTURE PROCEDURE – LEAN DROP METHOD.)  
 LIGHT DUTY (10-30) TRUCKS

**NOTE:** Refer to "Idle Mixture Adjustments" or "Idle Stop Solenoid Adjustments", as applicable, in Section 6M (Service Manual), under carburetors before using the following charts.

**NOTE:** All Idle Speeds listed are to be set with Air Conditioning OFF.

**UNLESS OTHERWISE NOTIFIED:** Always use current specifications that agree with the "Vehicle Emission Control Information" sticker on the vehicle.

**LIGHT DUTY EMISSION VEHICLES**

**GM 102 250 CU. IN. – FEDERAL**

**TRANSMISSION**

	<u>Automatic</u>	<u>Manual</u>
Exhaust Emission Control System	CCS-EGR	AIR-EGR
Timing (°BTC @ RPM)	8° @ 600	8° @ 850
(* Solenoid Adj. (RPM) energized (curb idle)	600 (DR)	850 (N)
Lean Drop Idle Mixture (RPM)	650/600 (DR)	950/850 (N)
(* de-energized (low idle)(RPM)	450 (DR)	450 (N)

**GM 102 250 CU. IN. – CALIFORNIA**

**TRANSMISSION**

	<u>Automatic</u>	<u>Manual</u>
AIR-EGR Exhaust Emission Control		
Timing (°BTC @ RPM)		8° @ 850
(* Solenoid Adj. (RPM) energized (curb idle)	N/A	850 (N)
Lean Drop Idle Mixture (RPM)		950/850 (N)
(* de-energized (low idle)(RPM)		450 (N)

**GM 104-2 350 CU. IN. 2BBL – FEDERAL**

**TRANSMISSION**

	<u>Automatic</u>	<u>Manual</u>
AIR-EGR Exhaust Emission Control		
Timing (°BTC @ RPM)	8° @ 600	0° @ 900
(* Solenoid Screw (RPM)	600 (DR)	900 (N)
Lean Drop Idle Mixture (RPM)	650/600 (DR)	1000/900 (N)
(* de-energized (low idle)(RPM)	500 (DR)	500 (N)

**GM 104-4 350 CU. IN. 4BBL FEDERAL (EXC. C-K 10 & 20 SUBURBAN AND G20 & 30 SPORTVANS)**

	<u>Auto. Exc. Versavan (COPO)</u>	<u>Auto Versavan (COPO)</u>	<u>Manual</u>
Exhaust Emission Control System	CCS-EGR	AIR-EGR	AIR-EGR
Timing (°BTC @ RPM)	8° @ 600	8° @ 600	8° @ 900
(* Solenoid Screw (RPM)	600 (DR)	600 (DR)	900 (N)
Lean Drop Idle Mixture (RPM)	650/600 (DR)	630/600 (DR)	950/900 (N)
(* de-energized (low idle)(RPM)	500 (DR)	500 (DR)	500 (N)

**GM 104-4 350 CU. IN. 4BBL FEDERAL C-K 10 & 20 SUBURBANS AND G20 & 30 SPORTVANS**

	<u>Auto</u>	<u>Manual Exc. Suburban</u>	<u>Manual Suburban</u>
AIR-EGR Exhaust Emission Control			
Timing (°BTC @ RPM)	12° @ 600	8° @ 900	6° @ 900
(* Solenoid Screw (RPM) energized (curb idle)	600 (DR)	900 (N)	900 (N)
Lean Drop Idle Mixture (RPM)	630/600 (DR)	950/900 (DR)	950/900 (N)
(* de-energized (low idle)(RPM)	500 (DR)	500 (DR)	500 (N)

SPECIFICATIONS 18

GM 104-4 350 CU. IN. 4BBL CALIFORNIA

	Auto Exc. Suburban	Auto Suburban	Manual
AIR-EGR Exhaust Emission Control Timing (°BTC @ RPM)	8° @ 600	6° @ 600	4° @ 900
(* Solenoid Screw (RPM) energized (curb idle)	600 (DR)	600 (DR)	900 (N)
Lean Drop Idle Mixture (RPM)	630/600 (DR)	630/600 (DR)	950/900 (N)
(* de-energized (low idle)(RPM)	500 (DR)	500 (DR)	500 (N)

GM 105 454 CU. IN. – FEDERAL

TRANSMISSION

	Automatic	Manual
AIR-EGR Exhaust Emission Control Timing (°BTC @ RPM)	10° @ 600	
(* Solenoid Screw (RPM) energized (curb idle)	600 (DR)	N/A
Lean Drop Idle Mixture (RPM)	630/600 (DR)	
(* de-energized (low idle)(RPM)	500 (DR)	

GM 105 454 CU. IN. – CALIFORNIA

TRANSMISSION

	Automatic	Manual
AIR-EGR Exhaust Emission Control Timing (°BTC @ RPM)	10° @ 600	
(* Solenoid Screw (RPM) energized (curb idle)	600 (DR)	N/A
Lean Drop Idle Mixture (RPM)	630/600 (DR)	
(* de-energized (low idle)(RPM)	500 (DR)	

HEAVY DUTY EMISSION VEHICLES

Family	Engine (CID)	Curb Idle Speed (RPM)	Timing (°BTC)	Lean Drop Idle Mixture Settings (RPM)	Low Idle
GM111	250	600	6	700/600	450
GM112	292	600	8	700/600	450
GM113	350/4bbl	600	4	750/600	—
GM115	454	700	8	800/700	500

## IDLE "CO" ADJUSTMENT SPECIFICATIONS

ALSO REFER TO ALTERNATE METHOD TO LEAN DROP UNDER, "IDLE MIXTURE ADJUSTMENT" PROCEDURES IN THE SERVICE MANUAL IF RELIABLE CO METER IS AVAILABLE.

NOTE: Idle Speed and Timing Adjustment Specifications are the same for both lean drop and idle CO settings.

LIGHT DUTY EMISSION VEHICLES

	Max. Acceptable CO Level (%)	If Over Max. Acceptable Level Reset to (% or Less)
GM 102 (250 cu. in.)	.3	.3 or below
GM 104-2 (350 cu. in.)	.5	.5 or below
GM 104-4 (350 cu. in.)	.5	.5 or below
GM 105 (454 cu. in.)	.5	.5 or below

HEAVY DUTY EMISSION VEHICLES

Engine Family	Max. Acceptable CO Level (%) @ Level	If Over Max. Acceptable Level Reset to (% or Less)
GM 111 (250 cu. in.)	2.0	2.0
GM 112 (292 cu. in.)	0.3	0.3
GM 113 (350 cu. in. 4bbl.)	0.5	0.5
GM 115 (454 cu. in.)	0.5	0.5

## ENGINE ELECTRICAL

### SECTION 6Y

#### BATTERY

Model No.	Application	No. of Plates Per Cell	Cranking Power @ 0° F. (Watts)	25 Amp Reserve Capacity (Minutes)
1980199 (Y87)	250 L-6	9	2300	60
1980200 (R89)	292, 350 V-8	11	2900	100
1980204 (R89W)	454 V-8 & RPO Option	15	3750	145

#### GENERATORS

Model No.	Application	Delco Remy Spec. No.	Field Current Amps. (80° F.)	Cold Output*			Rated Hot Output** Amps.
				Spec. Volts	Amps. @ 2000 RPM	Amps. @ 5000 RPM	
1100497	250 CID L-6 Engine (Base)	4519	4.4 - 4.9	xxx	xxx	3600 - @ 7000 RPM	37
1102347	250 or 292 CID L-6 Engine W/K-76	4522	4.0 - 4.5	xxx	xxx	55	61
1102346	250 CID L-6 Engine W/K-79	4521	4.0 - 4.5	xxx	xxx	37	42
1102382	292 CID L-6 Engine (Base)	4521	4.0 - 4.5	xxx	xxx	37	42
1102383	292 CID L-6 Engine W/K-76	4522	4.0 - 4.5	xxx	xxx	55	61
1100934	350 & 454 CID V-8 Engines (Base)	4519	4.4 - 4.5	xxx	xxx	36 - @ 7000 RPM	37
1100597	350 & 454 CID V-8 Engines W/K-76	4522	4.0 - 4.5	xxx	xxx	55	61
1100573	350 & 454 CID V-8 Engines W/K-79	4521	4.0 - 4.5	xxx	xxx	37	42
1100575	RPOK77	4520	4.0 - 4.5	xxx	xxx	50	55

\*Generator temperature approximately 80° F.      \*\*Ambient temperature 80° F.      xxx-Voltmeter not needed for cold output check. Load battery with carbon pile to obtain maximum output.

## STARTING MOTOR

Model No.	Spec No.	Free Speed		
		Volts	Amperes	RPM
1108365	3573	9	50-80*	5500-10,500
1108367				
1108427	2438	9	55-80*	3500-6000
1108360				
1108430	3563	9	65-95*	7500-10,500
1108480	3573	9	50-80*	5500-10,500
1108502	3563	9	65-95*	7500-10,500

\*Includes Solenoid

## IGNITION COIL

APPLICATION	PRIMARY RESISTANCE @ 75° F.	SECONDARY RESISTANCE	IGNITION RESISTOR	
	- OHMS -	- OHMS -	TYPE	OHMS
L-6 Engines	1.41 - 1.65	3,000 - 20,000	In Wiring Harness	1.8
V-8 Engines	1.77 - 2.01	3,000 - 20,000	In Wiring Harness	1.35

## DISTRIBUTOR

Application		Ignition Distributor (Product Part No.)	Centrifugal Advance † (Crank Degrees @ Engine RPM)	Vacuum Advance (In Crank Degrees)	Point Dwell Setting	Trans.	Original Equipment Spark Plug
250 C.I.D. L-6 Engine	10 Series Exc. G Models	1110499	<b>C-4797</b> 0° @ 1100 14° @ 2300 24° @ 4100	<b>C-3933</b> 0 @ 6-8" Hg. 24° @ 14.5-15.5" Hg.	31° - 34°	All	AC-R46T
250 C.I.D. L-6 Engine	10 Series G Models	1110500					
250 C.I.D. L-6 Engine	20-30 Series Exc. G Models	1110520	<b>C-4797</b> 0° @ 1100 14° @ 2300 24° @ 4100	<b>C-6005</b> 0° @ 12.7-13.2" Hg. 10° @ 12.7-13.5" Hg.	31° - 34°	All	AC-R46T
250 C.I.D. L-6 Engine	20-30 Series G Models	1110525					
292 C.I.D. L-6 Engine	20-30 Series	1110518	<b>C-4797</b> 0° @ 1100 2° @ 1270 14° @ 2300 24° @ 4100	<b>C-6005</b> 0° @ 9-11" Hg. 10° @ 12.7-13.5" Hg.	31° - 34°	All	AC-R44T
350 C.I.D. V-8 Engine RPO LS-9	C, K 10 Sub.	1112093	<b>C-4818</b> 0° @ 1100 RPM 11° @ 2400 RPM 18° @ 4200 RPM	<b>C-6001</b> 0° @ 5-7" Hg. 15° @ 13-14" Hg.  <b>C-6055</b> 0° @ 2-4" Hg. 14° @ 7.5-8.5" Hg.	29° - 31°	All	AC-R44T
	G 10-30 (Fed. & Calif.)	1112847				Auto.	
	C, K 10-20 exc. Sub. (Calif.)						
350 C.I.D. V-8 Engine RPO LF-5	C, K, G (Fed.)	1112543	<b>C-4817</b> 0° @ 1000 RPM 10° @ 1800 RPM 15° @ 2400 RPM 22° @ 4200 RPM	<b>C-6001</b> 0° @ 5-7" Hg. 15° @ 13-14" Hg.	29° - 31°	All	AC-R44T
350 C. I. D. V-8 Engine RPO LS-9	C, K Sub-urban, G 10-30 Spt. Van (Fed.)	1112848	<b>C-4888</b> 0° @ 900 14° @ 4200	<b>C-6055</b> 0° @ 2-4" Hg. 14° @ 7.5-8.5" Hg.	29° - 31°	Auto.	AC-R44T
350 C.I.D. V-8 Engine RPO LS-9	C 10, K 10-20 Suburban (Fed.)	1112844	<b>C-4815</b> 0° @ 1000 RPM 20° @ 4200 RPM	<b>C-6055</b> 0° @ 2-4" Hg. 14° @ 7.5-8.5" Hg.	29° - 31°	Manual	AC-R44T
	C-10 Suburban (Calif.)						

† Nominal Advance  $\pm 2^\circ$

## DISTRIBUTOR (CONT'D.)

Application		Ignition Distributor Product Part No.)	Centrifugal Advance (Crank Degrees @ Engine RPM)	Vacuum Advance (In Crank Degrees)	Point Dwell Setting	Trans.	Original Equipment Spark Plug
350 C.I.D. V-8 Engine RPO LS-9	C, K-10 exc. Sub., G10-30 (Calif.)	1112849	<b>C-4817</b> 0° @ 1000 10° @ 1800 15° @ 2400 22° @ 4200	<b>C-6055</b> 0° @ 2-4" Hg. 14° @ 7.5-8.5" Hg.	29° - 31°	Manual	AC-R44T
350 C.I.D. V-8 Engine RPO LS-9	G, P-30 Motor Home	1112097	<b>C-4890</b> 0° @ 1200 17° @ 2800 22° @ 4200	<b>C6006</b> 0° 7-9" Hg. 10° @ 12.2-13.5" Hg.	29° - 31°	All	AC-R44T
454 C.I.D. V-8 Engine	C, K-10 Series	1112113	<b>C-4818</b> 0° @ 1100 11° @ 2400 18° @ 4200	<b>C-3032</b> 0° @ 5-7" Hg. 20° @ 14.2-15.7 Hg.	29° - 31°	All	AC-R44T
454 C.I.D. V-8 Engine	C, K Series Suburban	1112504	<b>C-4818</b> 0° @ 1100 11° @ 2400 18° @ 4200	<b>C-3036</b> 0° @ 7-9" Hg. 16° @ 15-16" Hg.	29° - 31°	Auto	AC-R44T
454 C.I.D.	C, K 20-30 Series	1112105	<b>C-6109</b> 0° @ 1100 RPM 14° @ 2800 20° @ 4200 RPM	<b>C-3932</b> 0° @ 5-7 Hg. 24° @ 13.5-14.3" Hg.	29° - 31°	All	AC-R44T

† Nominal Advance  $\pm 2^\circ$



# CLUTCH AND MANUAL TRANSMISSION

## SECTION 7M

### THREE SPEED SAGINAW

Clutch Gear Retainer to Case Bolts . . . . .	15 ft. lbs.
Side Cover to Case Bolts . . . . .	15 ft. lbs.
Extension to Case Bolts . . . . .	45 ft. lbs.
Shift Lever to Shifter Shaft Bolts . . . . .	25 ft. lbs.
Lubrication Filler Plug . . . . .	18 ft. lbs.
Transmission Case to Clutch Housing Bolts . .	75 ft. lbs.
Crossmember to Frame Nuts . . . . .	25 ft. lbs.
Crossmember to Mount Bolts . . . . .	40 ft. lbs.
2-3 Cross Over Shaft Bracket Retaining Nut .	18 ft. lbs.
1-Rev. Swivel Attaching Bolt . . . . .	20 ft. lbs.
Mount to Transmission Bolt . . . . .	50 ft. lbs.

### THREE SPEED MUNCIE

Clutch Gear Retainer to Case Bolts . . . . .	15 ft. lbs.
Side Cover to Case Bolts . . . . .	15 ft. lbs.
Extension to Case Bolts . . . . .	45 ft. lbs.
Shift Lever to Shifter Shaft Bolts . . . . .	25 ft. lbs.
Lubrication Filler Plugs . . . . .	18 ft. lbs.
Transmission Case to Clutch Housing Bolts . .	75 ft. lbs.
Crossmember to Frame Nuts . . . . .	25 ft. lbs.
Crossmember to Mount Bolts . . . . .	40 ft. lbs.
Transmission Drain Plug . . . . .	30 ft. lbs.
2-3 Cross Over Shaft Bracket Retaining Nut .	18 ft. lbs.
1-Rev. Swivel Attaching Bolt . . . . .	20 ft. lbs.
Mount to Transmission Bolt . . . . .	50 ft. lbs.

### FOUR SPEED MUNCIE

Rear Bearing Retainer . . . . .	18 ft. lbs.
Cover Bolts . . . . .	25 ft. lbs.
Filler Plug . . . . .	35 ft. lbs.
Drain Plug . . . . .	35 ft. lbs.
Clutch Gear Bearing Retainer Bolts . . . . .	18 ft. lbs.
Universal Joint Front Flange Nut . . . . .	95 ft. lbs.
Power Take Off Cover Bolts . . . . .	18 ft. lbs.
Parking Brake . . . . .	22 ft. lbs.
Countergear Front Cover Screws . . . . .	25 in. lbs.
Rr. Mainshaft Lock Nut (4 Whl. Drive Mdl.)	95 ft. lbs.
Transmission To Clutch Housing Bolts . . . . .	75 ft. lbs.
Crossmember to Mount . . . . .	40 ft. lbs.
Mount to Transmission . . . . .	50 ft. lbs.

### NEW PROCESS TRANSFER CASE MODEL 205

Idler Shaft Lock Nut . . . . .	200 ft. lbs.
Idler Shaft Cover Bolts . . . . .	18 ft. lbs.
Front Output Shaft Front Bearing Retainer Bolts . . . . .	30 ft. lbs.
Front Output Shaft Yoke Lock Nut . . . . .	200 ft. lbs.
Rear Output Shaft Bearing Retainer Bolts . . .	30 ft. lbs.
Rear Output Shaft Housing Bolts . . . . .	30 ft. lbs.
Rear Output Shaft Yoke Lock Nut . . . . .	150 ft. lbs.
P.T.O. Cover Bolts . . . . .	15 ft. lbs.
Front Output Shaft Rear Bearing Retainer Bolts . . . . .	30 ft. lbs.
Drain and Filler Plugs . . . . .	30 ft. lbs.
Transfer Case to Frame Bolts . . . . .	130 ft. lbs.
Transfer Case to Adapter Bolts . . . . .	25 ft. lbs.
Adapter Mount Bolts . . . . .	25 ft. lbs.
Transfer Case Bracket to Frame Nuts (Upper)	30 ft. lbs.
Transfer Case Bracket to Frame Nuts (Lower)	65 ft. lbs.
Adapter to Transmission Bolts - (Manual Transmission) . . . . .	22 ft. lbs.
Adapter to Transmission Bolts - (Automatic Transmission) . . . . .	35 ft. lbs.
Transfer Case Control Mounting Bolt . . . . .	100 ft. lbs.

### DANA TRANSFER CASE MODEL 20

Shift Rail Set Screws . . . . .	15 ft. lbs.
Front Output Shaft Rear Cover Bolts . . . . .	30 ft. lbs.
Front Output Shaft Front Bearing Retainer .	30 ft. lbs.
Front Output Shaft Yoke Lock Nut . . . . .	150 ft. lbs.
Intermediate Shaft Lock Plate Bolt . . . . .	15 ft. lbs.
Rear Output Shaft Housing Bolts . . . . .	30 ft. lbs.
Rear Output Shaft Yoke Lock Nuts . . . . .	150 ft. lbs.
Case Bottom Cover Bolts . . . . .	15 ft. lbs.
Transfer Case to Adapter Bolts . . . . .	45 ft. lbs.
Transfer Case to Frame Bolts . . . . .	45 ft. lbs.
Adapter Mount Bolts . . . . .	25 ft. lbs.
Adapter to Transmission Bolts . . . . .	45 ft. lbs.
Transfer Case Bracket to Frame Nuts (Upper)	30 ft. lbs.
Transfer Case Bracket to Frame Nuts (Lower)	65 ft. lbs.
Transfer Case Control Mounting Bolt . . . . .	100 ft. lbs.

**NEW PROCESS TRANSFER CASE MODEL 203**

Adapter to Transfer Case Attaching Bolts . . .	38 ft. lbs.	Adapter Mount Bolts . . . . .	25 ft. lbs.
Adapter to Transmission Attaching Bolts . . .	40 ft. lbs.	Intermediate Case to Range Box Bolts . . . . .	30 ft. lbs.
Transfer Case Bracket to Frame nuts (upper)	50 ft. lbs.	Front Output Bearing Retainer Bolts . . . . .	30 ft. lbs.
Transfer Case Bracket to Frame nuts (lower)	65 ft. lbs.	Output Shaft Yoke Nuts . . . . .	150 ft. lbs.
Transfer Case Shift Lever Attaching Nuts . . .	25 ft. lbs.	Front Output Rear Bearing Retainer Bolts . . .	30 ft. lbs.
Transfer Case Shift Lever Rod Swivel		Differential Assembly Screws . . . . .	45 ft. lbs.
Lock Nuts . . . . .	50 ft. lbs.	Rear Output Shaft Housing . . . . .	30 ft. lbs.
Transfer Case Shift Lever Locking Arm Nut . .	150 in. lbs.	Poppet Ball Retainer Nut . . . . .	15 ft. lbs.
Skid Plate Attaching Bolt Retaining Nuts . . .	45 ft. lbs.	Power Take Off Cover Bolts . . . . .	15 ft. lbs.
Crossmember Support Attaching Bolt		Front Input Bearing Retainer Bolts . . . . .	20 ft. lbs.
Retaining Nut . . . . .	45 ft. lbs.	Filler Plug . . . . .	25 ft. lbs.

**AUTOMATIC TRANSMISSIONS**

**SECTION 7A**

**TURBO HYDRA-MATIC 350**

Pump Cover to Pump Body . . . . .	17 ft. lbs.
Pump Assembly to Case . . . . .	18-1/2 ft. lbs.
Valve Body and Support Plate . . . . .	130 in. lbs.
Parking Lock Bracket . . . . .	29 ft. lbs.
Oil Suction Screen . . . . .	40 in. lbs.
Oil Pan to Case . . . . .	130 in. lbs.
Extension to Case . . . . .	25 ft. lbs.
Modulator Retainer to Case . . . . .	130 in. lbs.
Inner Selector Lever to Shaft . . . . .	25 ft. lbs.
Detent Valve Actuating Bracket . . . . .	52 in. lbs.
Converter to Flywheel Bolts . . . . .	35 ft. lbs.
Under Pan to Transmission Case . . . . .	110 in. lbs.
Transmission Case to Engine . . . . .	35 ft. lbs.
Oil Cooler Pipe Connectors to Transmission	
Case or Radiator . . . . .	125 in. lbs.
Oil Cooler Pipe to Connectors . . . . .	10 ft. lbs.
Detent Cable to Transmission . . . . .	75 in. lbs.
Detent Cable to Carb . . . . .	112 in. lbs.

**TURBO HYDRA-MATIC 400/475**

Pump Cover Bolts . . . . .	18 ft. lbs.
Parking Pawl Bracket Bolts . . . . .	18 ft. lbs.
Center Support Bolt . . . . .	23 ft. lbs.
Pump to Case Attaching Bolts . . . . .	18 ft. lbs.
Extension Housing to Case Attaching Bolts . . .	23 ft. lbs.
Rear Servo Cover Bolts . . . . .	18 ft. lbs.
Detent Solenoid Bolts . . . . .	7 ft. lbs.
Control Valve Body Bolts . . . . .	8 ft. lbs.
Bottom Pan Attaching Screws . . . . .	12 ft. lbs.
Modulator Retainer Bolt . . . . .	18 ft. lbs.
Governor Cover Bolts . . . . .	18 ft. lbs.
Manual Lever to Manual Shaft Nut . . . . .	8 ft. lbs.
Manual Shaft to Inside Detent Lever . . . . .	18 ft. lbs.
Linkage Swivel Clamp Nut . . . . .	43 ft. lbs.
Converter Dust Shield Screws . . . . .	93 ft. lbs.
Transmission to Engine Mounting Bolts . . . . .	35 ft. lbs.
Converter to Flywheel Bolts . . . . .	35 ft. lbs.
Rear Mount to Transmission Bolts . . . . .	40 ft. lbs.
Rear Mount to Crossmember Bolt . . . . .	40 ft. lbs.
Crossmember Mounting Bolts . . . . .	25 ft. lbs.
Oil Cooler Line . . . . .	10 ft. lbs.
Line Pressure Take-Off Plug . . . . .	13 ft. lbs.
Strainer Retainer Bolt . . . . .	10 ft. lbs.
Oil Cooler Pipe Connectors to Transmission	
Case or Radiator . . . . .	125 in. lbs.
Oil Cooler Pipe to Connector . . . . .	10 in. lbs.
Downshift Switch to Bracket . . . . .	22 in. lbs.

## STEERING

### SECTION 9

#### TORQUE VALUES

Components	C10-30	K10-20	G10-30	P10-30
Tie Rod Ball Joint Nut Outer and Inner	C 10 35 lbs. ft.** C 20-30 45 lbs. ft.***	45 lbs. ft.	G 10 35 lbs. ft.** G 20-30 45 lbs. ft.***	
Tie Rod Clamp Bolt	22 lbs. ft.	35 lbs. ft.	22 lbs. ft.	
Idler Arm Mounting Bolts	30 lbs. ft.	—	30 lbs. ft.	
Idler Arm to Relay Rod Nut	60 lbs. ft.	—	70 lbs. ft.	60 lbs. ft.
Pitman Arm to Relay Rod Nut	60 lbs. ft.	—	70 lbs. ft.	60 lbs. ft.
Steering Connecting Rod Nuts	—	50 lbs. ft. Plus next slot for cotter pin.	—	
Steering Connecting Rod Clamps	—	40 lbs. ft.	—	—
Pitman Arm to Pitman Shaft Nut	180 lbs. ft. power 140 lbs. ft. manual	90 lbs. ft.	180 lbs. ft. power 140 lbs. ft. manual	
Steering Gear Mounting Bolts	65 lbs. ft.		110 lbs. ft.	65 lbs. ft.
Steering Wheel Nut	30 lbs. ft.		40 lbs. ft.	30 lbs. ft.
Lower Mast Jacket Bearing Adjustment	—		.50 ± .04	1.26 ± .02
Power Steering Belt Tension	125 lbs. New — 75 lbs. Used			
Pump Pulley Nut	60 lbs. ft.			
Pump Pressure	1200-1300 psi.		G10-20 900-1000 p.s.i. G30 1200-1300 p.s.i.	1200-1300 p.s.i. Motor Home 1350-1450 p.s.i.
Pump Bracket and Support	25 lbs. ft.			
Power Steering Hose Clamp Screws	15 lbs. in.			
Power Steering Gear Hose Fittings	30 lbs. ft.			
Flexible Coupling Bolt & Studs	18 lbs. in.			20 lbs. ft.
Lower Mast Jacket Bearing Clamp or Coupling Bolt	—	30 lbs. ft.		
Lower Coupling to Wormshaft Clamp Bolt	30 lbs. ft.			75 lbs. ft.\$
Column to Dash Panel Clamp Screws	—	125 lbs. in.		
Toe Panel Cover Screws	30 lbs. in.			24 lbs. in.
Firewall Bracket Clamp Bolt	90 lbs. in.		150 lbs. in.	98 lbs. in.
Lower Bearing Adjusting Ring Bolt	—	70 lbs. in.		

\* Upper and Lower Universal Joint Clamp

\*\* Plus Torque Required to Aline Cotter Pin, Max. 50 lbs. ft.

\*\*\* Plus Torque Required to Aline Cotter Pin, Max. 60 lbs. ft.

\$ Upper and Lower Universal Joint Clamp

**MANUAL STEERING GEAR**

Components	G10 - 30	C10 - 30 P10	K10 - 20	P20 - 30
Thrust Bearing Preload	6 to 11 lbs. in.	4 to 6 lbs. in.		9 to 12 lbs. in.
Adjuster Plug Lock Nut	85 lbs. ft.			
Over Center Preload	5 to 11 lbs. in.*	4 to 10 lbs. in.*		9 to 13 lbs. in.*
Over Center Lock Nut	35 lbs. ft.			
Total Steering Gear Preload	18 lbs. in. Max.	14 lbs. in. Max.		25 lbs. in. Max.

\* In excess of Thrust bearing preload.

**POWER STEERING GEAR**

Components	All C, P, K and G
Steering Gear Ball Drag	3 lbs. in. Max.
Thrust Bearing Preload	1/2 to 2 lbs. in.*
Adjuster Plug Locknut	80 lbs. ft.
Over-Center Preload	3 - 6** lbs. in.
Over-Center Adjusting Screw Locknut	35 lbs. ft.
Total Steering Gear Preload	14 lbs. in. Max.

\*In excess of ball drag.

\*\*In excess of ball drag and thrust bearing preload.

STEERING GEAR RATIOS	MANUAL		POWER	
	Gear	Overall	Gear	Overall
G10-20	24:1	29.4:1 to 36.7:1	17.5:1	21.4:1 to 26.7:1
G30	24:1	29.4:1 to 36.4:1	17.5:1	21.4:1 to 26.5:1
P10	24:1	29.1:1 to 35.5:1	17.5:1	21.2:1 to 25.7:1
P20-30	24:1	29.1:1 to 35.3:1	17.5:1	21.2:1 to 25.7:1
Motor Home	-	-	17.5:1	20.0:1 to 27.4:1
C 10	24:1	29.1:1 to 37.0:1	16:1 to 13:1	16.9:1 to 20.2:1
C20-30	24:1	29.4:1 to 36.3:1	16:1 to 13:1	17.2:1 to 20.6:1
K10-20	24:1	24.6:1 to 28.0:1	20:1 to 16.4:1	16.7:1 to 21.5:1

STEERING COLUMN	C and K
Floor Pan Cover Screws	35 lbs. in.
Floor Pan Cover Clamp Screws	35 lbs. in.
Dash Panel Bracket to Column Screws	15 lbs. ft.
Dash Panel Bracket to Dash Nuts	20 lbs. ft.
Ignition Switch Screw	35 lbs. in.
Turn Signal Switch Screws	25 lbs. in.
Column Lock Plate Cover Screws	20 lbs. in.
Turn Signal Housing Screws	45 lbs. in.
Lock Bolt Spring Screw (Tilt Column)	35 lbs. in.
Bearing Housing Support Screws Tilt Column	60 lbs. in.

## WHEELS AND TIRES

### SECTION 10

#### WHEELS

Wheel Nut Torques - 10-30 Series

SERIES	DESCRIPTION	TORQUES
10	7/16" Bolts	70-90 ft. lbs.
10	1/2" Bolts	75-100 ft. lbs.
20, 30 Single Wheels	9/16" Bolts	90-120 ft. lbs.
20, 30 Dual Wheels	9/16" Bolts	110-140 ft. lbs.
30	Heavy Duty Wheels 5/8" Bolts	130-180 ft. lbs.

#### TIRES

See "Minimum Tire Inflation" and "Tire Load and Inflation Pressure" Charts in Section 10 of this Manual.

## SHEET METAL

### SECTION 11

#### TORQUE SPECIFICATIONS

	CK	G	P
Lock Support to Hood	150 in. lbs.	150 in. lbs.	
Lock Bolt Nut	30 ft. lbs.	40 ft. lbs.	
Bumper Bolt Nut	85 in. lbs.	150 in. lbs.	
Hood Hinge	35 ft. lbs.	18 ft. lbs.	
Hood Lock Catch	150 in. lbs.	18 ft. lbs.	
Lock Support to Rad. Support	18 ft. lbs.	18 ft. lbs.	
Rad. Support to Frame	35 ft. lbs.		30 ft. lbs.
Rad. Support to Fender	150 in. lbs.		
Fender Skirt to Fender	150 in. lbs.		150 in. lbs.
Fender to Cowl	35 ft. lbs.		
Rad. Grille Panel	150 in. lbs.		

# BODY AND CHASSIS ELECTRICAL

## SECTION 12

### LAMP BULB DATA G TRUCK

Used in	Quantity	Trade #	Power
Dome lamps	2	211	12 CP
Oil pressure indicator lamp	1	194	2 CP
Generator indicator lamp	1	194	2 CP
Instrument cluster lamps	3	194	2 CP
Headlamp beam indicator lamp	1	194	2 CP
Tail, stop and rear directional signal lamps	2	1157	3-32 CP
License lamp	1	67	4 CP
Directional signal (front park lamps)	2	1157	3-32 CP
Head Lamps <sup>1</sup>		6014	
Temperature Indicator Lamp	1	194	2 CP
Directional signal indicator lamp	2	194	2 CP
Marker lamps	4	168	3 CP
Brake warning indicator lamp	1	194	2 CP
Back-up lamp	2	1156	32 CP
Radio dial lamp	1	293	2 CP
Heater or A/C Control	1	1445	.7 CP
Transmission Control w/Tilt Wheel	1	1445	.7 CP

<sup>1</sup>Double filament sealed beam 60W high beam, 50W low beam.

### FUSES—CIRCUIT BREAKERS

The wiring circuits are protected from short circuits by a combination of fuses, circuit breakers, and fusible thermal links in the wiring itself. This greatly reduces the hazard of electrically caused fires in the vehicles.

The headlamp circuits are protected by a circuit breaker in the light switch. An electrical overload on the breaker will cause the lamps to go on and off, or in some cases to remain off.

In addition to a fuse, the windshield wiper motor is also protected by a circuit breaker. If the motor overheats, due to overloading caused by heavy snow, etc. the wipers will remain stopped until the motor cools.

Fuses located in the Junction Block beneath the dash on the driver's side are:	
Heater, Rear A/C	20 amp
Idle Stop Solenoid, T. C. S Time Delay Relay	
Transmission Downshift	3 amp
Cigarette Lighter	15 amp
Fuel Gauge, Brake Warning Lamp, Dome Lamp, Temperature Warning Lamp, Generator Warning Lamp, Oil Pressure Warning Lamp	3 amp
Directional Signal Indicator Lamp, Traffic Hazard	15 amp
Backing Lamp, Radio Dial Lamp, Radio	10 amp
Instrument Cluster Lamp, Heater Dial Lamp, Transmission Control Lamp with Tilt Wheel	3 amp
Dome Lamp, License Lamp, Parking Lamp, Side Marker Lamp, Stop Lamp, Tail Lamp	20 amp
Windshield Wiper	25 amp

In-Line fuses are located in the Ammeter and the rear A/C circuits.

Do not use fuses of higher amperage rating than those recommended above.

The following wiring harnesses are protected by a "fusible link" which is a special wire incorporated in the circuit; engine wiring and battery charging circuit, generator and forward lamp harness. Should an electrical overload occur, this wire will fail and prevent damage to the major harness.

### CIRCUIT BREAKERS

Device or circuit protected	Amperes	Location
Headlamp and parking lamp circuit	15 AMP	Light switch

### LAMP BULB DATA C-K-P TRUCK

Used in	Quantity	Trade #	Power
Dome lamp <sup>5</sup>	1	212	6 CP
Oil pressure indicator lamp <sup>1</sup>	1	194	2 CP
Generator indicator lamp <sup>1</sup>	1	194	2 CP
Instrument cluster lamps <sup>2</sup>	6	194 or 1895	2 CP
Headlamp beam indicator lamp	1	194	2 CP
Lamp assembly-tail & stop lamp	2	1157	3-32 CP
License lamp <sup>4</sup>	1	67	4 CP
Directional signal (front park lamps)	2	1157	3-32 CP
Head Lamps <sup>3</sup>		6014	
Temperature Indicator Lamp	1	194	2 CP
Directional signal indicator lamp	2	194	2 CP
Cab clearance and identification lamps: Suburban models	5	1155	4 CP
Forward Control models	5	67	4 CP
Other models	5	194	2 CP
Roof marker lamps <sup>6</sup>	5	194	2 CP
Brake Warning Indicator	1	194	2 CP
Transmission Control	1	1445	.7 CP
Backing lamp	2	1156	32 CP
Heater or A/C	1	1445	.7 CP
Corner marker lamps	7	67	4 CP
Cargo lamp	1	1142	21 CP
Radio Dial lamp	1	293	2 CP
Cruise Control lamp	1	53	1 CP
Courtesy lamp	1	1003	15 CP

On CA, KA 10-35 instrument clusters only.  
 3 lamps used on instrument cluster PA20-35 only.  
 Double filament sealed beam 60W high beam, 50W low beam.  
 2 lamps used with step bumper and P models.  
 2 required on Utility vehicles.  
 4 required on P models.

### FUSES—CIRCUIT BREAKERS

The wiring circuits are protected from short circuits by a combination of fuses, circuit breakers, and fusible thermal links in the wiring itself. This greatly reduces the hazard of electrically caused fires in the vehicles.

The headlamp circuits are protected by a circuit breaker in the light switch. An electrical overload on the breaker will cause the lamps to go on and off, or in some cases to remain off.

In addition to a fuse, the windshield wiper motor is also protected by a circuit breaker. If the motor overheats, due to overloading caused by heavy snow, etc., the wipers will remain stopped until the motor cools.

Fuses located in the Junction Block beneath the dash on the drivers side are:

Heater, Generator Warning Lamp	20 amp
Idle Stop Solenoid, Auxiliary Battery, Radio, T.C.S. Time Delay Relay, T.C.S. Solenoid, Transmission Downshift	10 amp
Cigarette Lighter, Clock, Dome Lamp, Cargo Lamp	20 amp
Cruise Control, Rear Window, Backing Lamp	10 amp
Fuel Gauge, Brake Warning Lamp, Temperature Warning Lamp, Parking Brake Warning Lamp, Oil Pressure Warning Lamp	3 amp
Courtesy Lamp, Roof Marker Lamp, License Lamp, Parking Lamp, Side Marker Lamp, Stop Lamp, Tail Lamp, Clearance Lamp	20 amp*
Directional Signal Indicator Lamp, Traffic Hazard	15 amp
Instrument Cluster Lamp, Heater Dial Lamp, Radio Dial Lamp, Cruise Control Lamp	3 amp
Windshield Wiper	25 amp

In-Line fuses are located in the Ammeter, Auxiliary Heater and Rear A/C Circuits.

Do not use fuses of higher amperage than those recommended above.

The following wiring harnesses are protected by a "fusible link" which is a special wire incorporated in the circuit; engine wiring and battery charging circuit, generator and forward lamp harness. Should an electrical overload occur, this wire will fail and prevent damage to the major harness.

\*30 amp. with UY1 Camper option.

### CIRCUIT BREAKERS

Device or circuit protected	Amperes	Location
Headlamp and parking lamp circuit	15 AMP	Light switch
Windshield wiper motor	8-10 AMP	Wiper motor

Section 12 (Continued)

**WINDSHIELD WIPERS**

TWO-SPEED WIPER	
Crank Arm Speed (RPM's) (No Load)	
Lo . . . . .	34 Min.
Hi . . . . .	65 Min.
Current Draw, AMPS	
No Load (Lo Speed - No Linkage) . . . . .	3.6
Stall (Lo Speed) . . . . .	12
WASHER	
Number of "squirts" at full pressure . . . . .	10
Pressure (PSI) . . . . .	11-15
Coil Resistance (ohms) . . . . .	6 ± 1

Classiccarlibrary.com

JAL

# RADIATOR AND GRILLE

## SECTION 13

### TORQUE SPECIFICATIONS

	CK	G	P
Grille to Tie Bar		50 in. lbs.	
Grille	18 ft. lbs.	18 ft. lbs.	
Mounting Panel	150 in. lbs.		150 in. lbs.
Fan Shroud	50 in. lbs.	42 in. lbs.	120 in. lbs. P (32) 50 in. lbs. P (42)
Coolant Recovery Tank Brkt.	28 in. lbs.	23 in. lbs.	28 in. lbs.

## BUMPERS

### SECTION 14

#### TORQUE SPECIFICATIONS C, P AND K

Front Bumper . . . . .	30 ft. lbs.
Front Bumper Bracket and Brace . . . . .	40 ft. lbs.
Rear Bumper to Outer Bracket . . . . .	30 ft. lbs.
Rear Bumper Outer Bracket and Brace . . . . .	38 ft. lbs.
License Plate Bracket . . . . .	18 ft. lbs.
Gravel Deflector . . . . .	85 in. lbs.
Rear Step Bumper to Bracket or Frame . . . . .	40 ft. lbs.

#### TORQUE SPECIFICATIONS G

Front Face Bar to Bracket . . . . .	24 ft. lbs.
Bracket to Cross Sill . . . . .	24 ft. lbs.
License Plate Bracket to Face Bar . . . . .	100 in. lbs.
Rear Face Bar to Brackets . . . . .	24 ft. lbs.
Bracket to Cross Sill . . . . .	24 ft. lbs.

## ACCESSORIES

### SECTION 15

#### CRUISE-MASTER

Solenoid Resistance . . . . .	5 ohms ± 1/4 ohm
Solenoid Wire Resistance . . . . .	40 ohms
Maximum allowable Vacuum Leakage rate for Servo unit . . . . .	5 inches of Vacuum Per Minute
	Not Greater than 1 inch of Vacuum per 10 seconds
Operational Test Speed . . . . .	60 MPH



classicalibrary.com

